

SCHITA de PROIECT

Compartiment **SP**;

Obiectul nr. 03

Statia nr. 3

Denumirea: *"Reconstructia si reparatia capitala a statiilor de asteptare
din str. Costiujeni, or. Codru"*

Birou de Proiectare: SRL "GAZMOLPROIECT" Lic.Ser.AMMII Nr.044641 din 29.05.14

PLAN DE INCADRARE
SC 1:35000

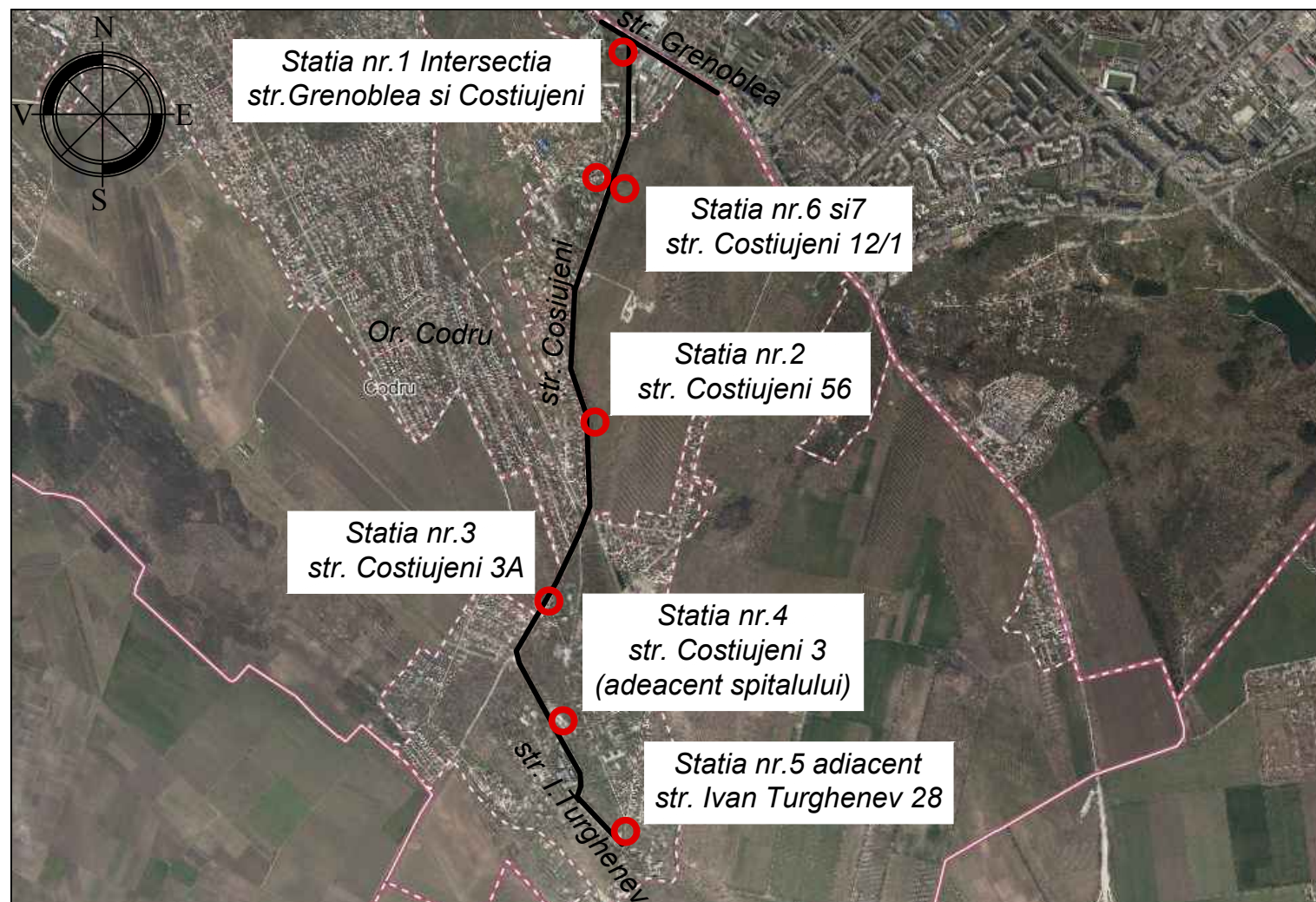

PLAN DE SITUATIE ÎN TERITORIU SC 1:1000

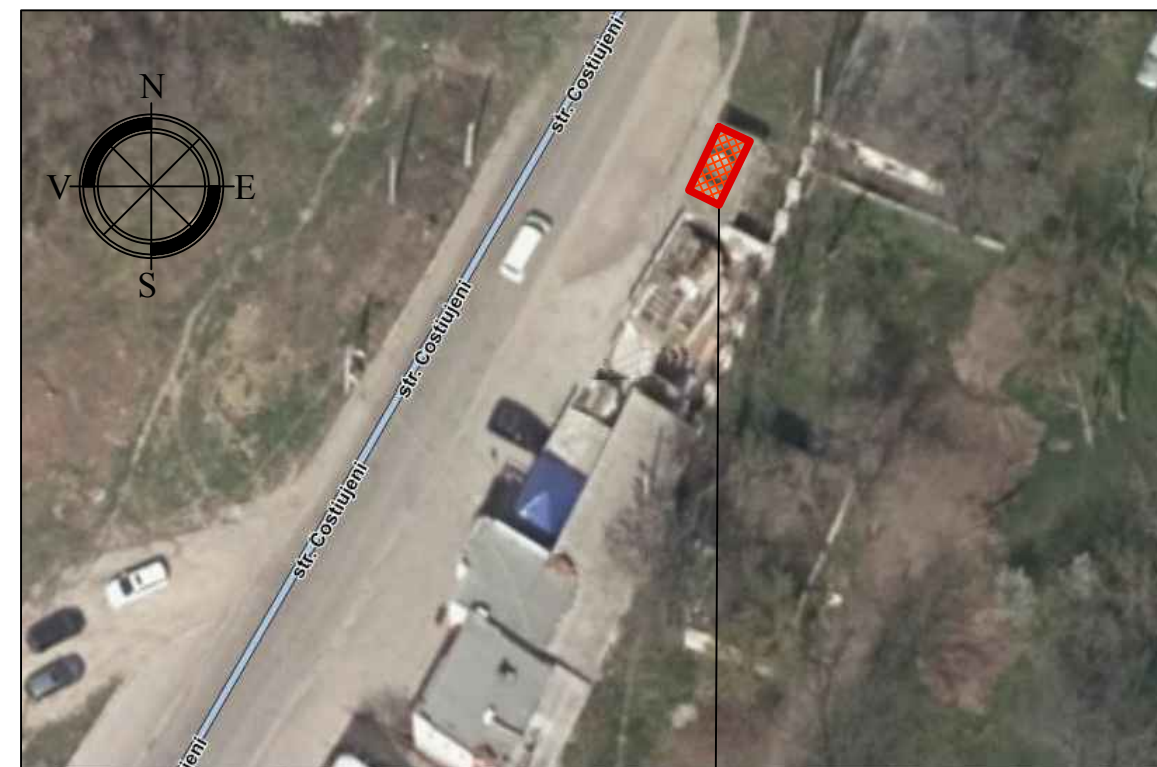

Obiectul solicitat

Stia nr.3
str. Costiujeni 3A

SEMNE CONVENTIONALE

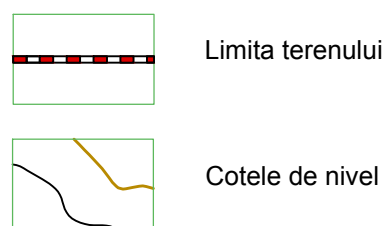

LEGENDA DE AMENAJARE A TERITORIULUI

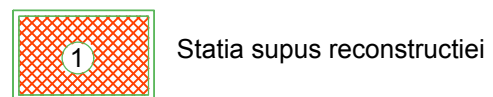

				003/2020-SP			
				"Reconstructia si reparatia capitala a statiilor de asteptare din str. Costiujeni, or. Codru"			
				Statie de asteptare	Etapa	Foia	Foi
					SC	1	
ISP				Plan general sc. 1:500			
Elaborat	Veverita S			Plan de incadrare in teritoriu sc. 1:5000			
				SRL "GazMolPoiect" Chişinău 2020			

SITUATIA EXISTENTA FOTO 1



SITUATIA EXISTENTA FOTO 2



SPECIFICATIA LUCRARILOR DE DEMONTARE

Nr.or.	Denumirea lucrarii	Lungimea m.l.	Inaltimea m.l.	suptarafata m.p.	volumul m.c.	cantitatea buc.	Nota
1	Demontarea elementelor din beton(PARDOSEA)		0,2	22,4	4,48		
2	Demontarea pamintului si gunoiului de piatra adeacent				4		
3	demontarea fundatiilor din beton				5,04		
4	demontarea placii din BA		0,2	27	5,4		
5	demontarea peretilor din BA prefabricat				~16		

Schema statiei existente supusa demontarii

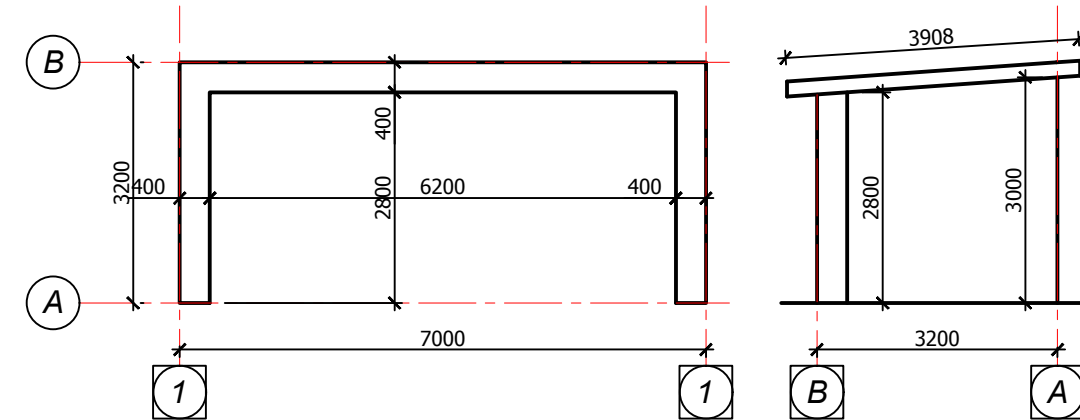

- Note:
- 1.Executarea lucrarilor sa corespunda cerintelor NCM A.08.02:2014 "Securitateap și sănătatea muncii în construcții"
 - 2.Demontarea blocurilor din piatră ale zidariei se va face prin frezarea sau forarea elementelor, iar dimensiunile acestora sa fie reduse la maxim, si doar dupa asigurarea ingradirei si protectiei.

				003/2020-SP		
				"Reconstructia si reparatia capitala a statiilor de asteptare din str. Costiujeni, or. Codru"		
				Statie de asteptare		
				Etapa	Foaia	Foi
				SC	2	
ISP Elaborat Veverita S				Situatia existenta Borderoul demontarilor		
				SRL "GazMolPoiect" Chișinău 2020		

Plan fundatie/plan stilpi Sc. 1:100

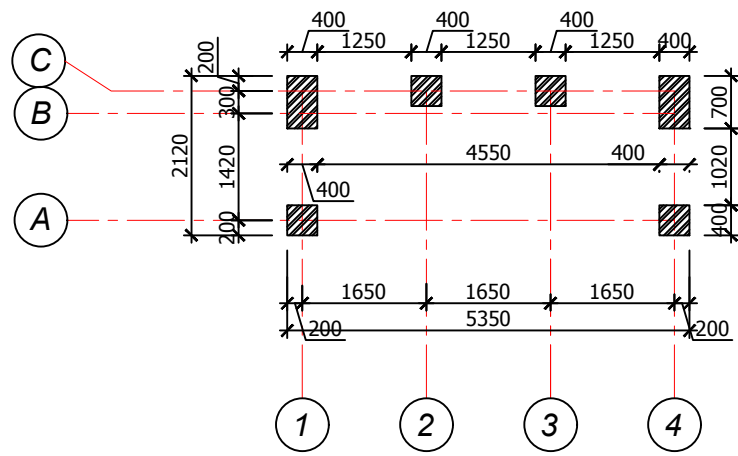

Plan piese inglobate Sc. 1:100

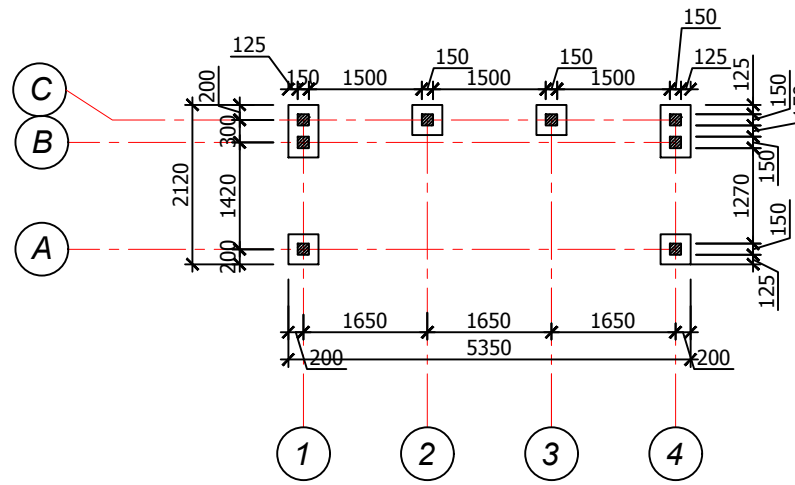

Plan stilpi metalici Sc. 1:100

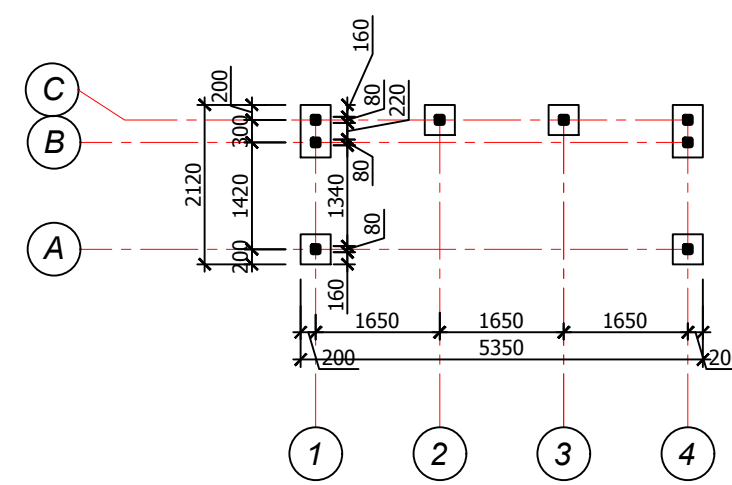

Pentru stilpi din BA

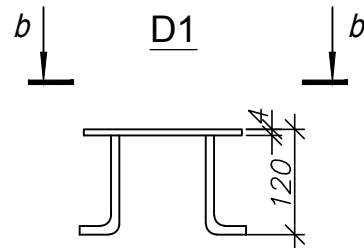
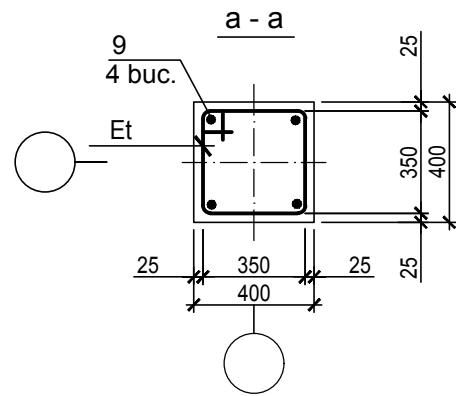

Pentru centura din BA

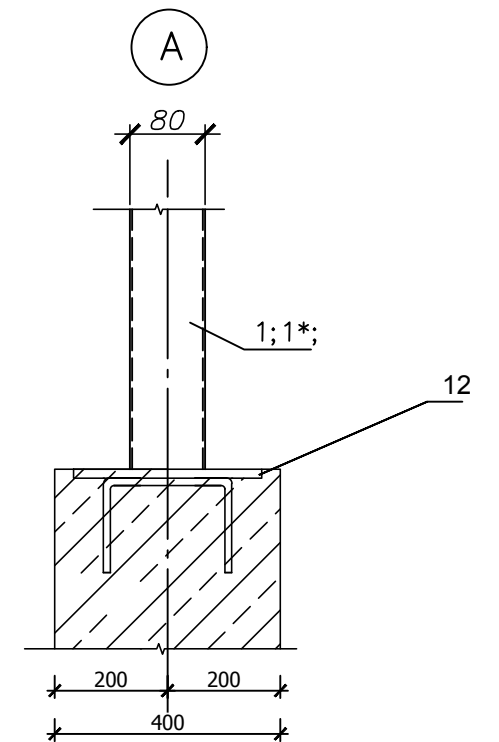
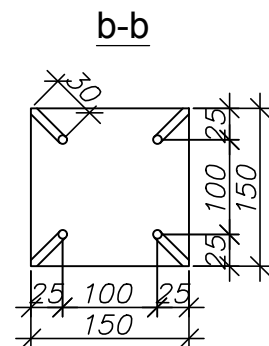
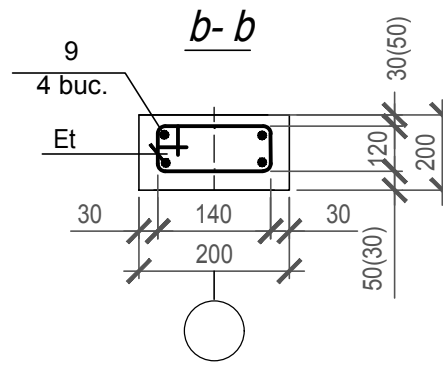

				003/2020-SP		
				"Reconstructia si reparatia capitala a statiilor de asteptare din str. Costiujeni, or. Codru"		
				Statie de asteptare		
				Etapa	Foaia	Foi
				SP	3	
ISP				SRL "GazMolProiect" Chişinău 2019		
Elaborat	Veverita S					
				Plan Fundatie sc.1:100 Plan stilpi, piese inglobate.		

Desfasurata axei 1 Sc. 1:50

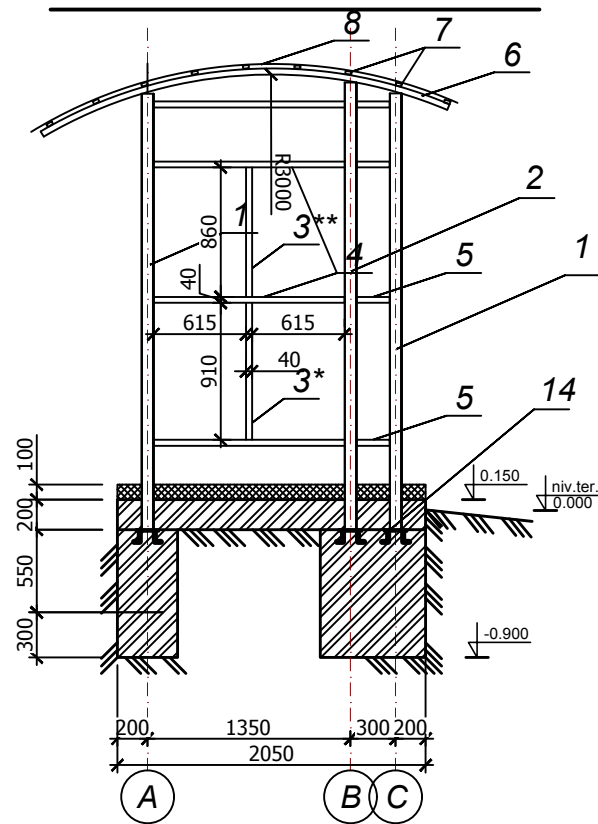

Desfasurata axei 2 si 3 Sc. 1:50

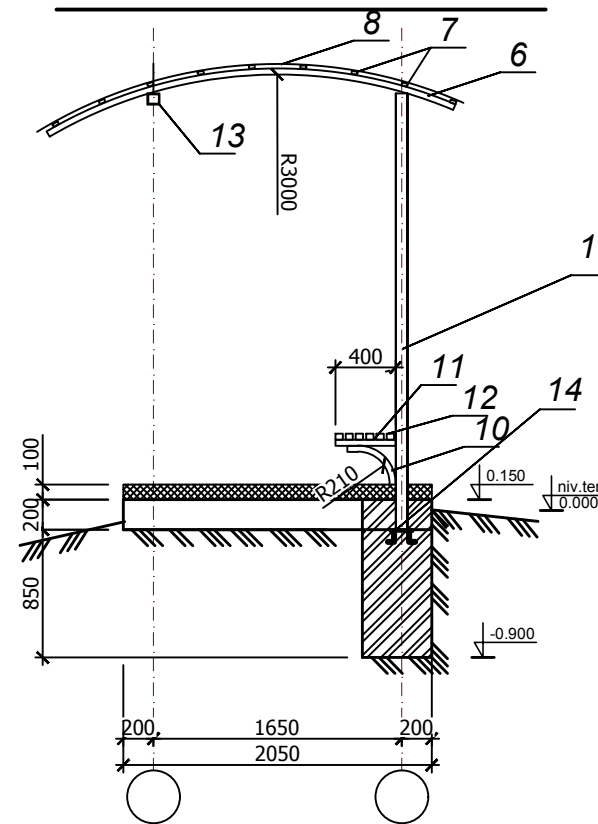

Desfasurata axei C Sc. 1:50

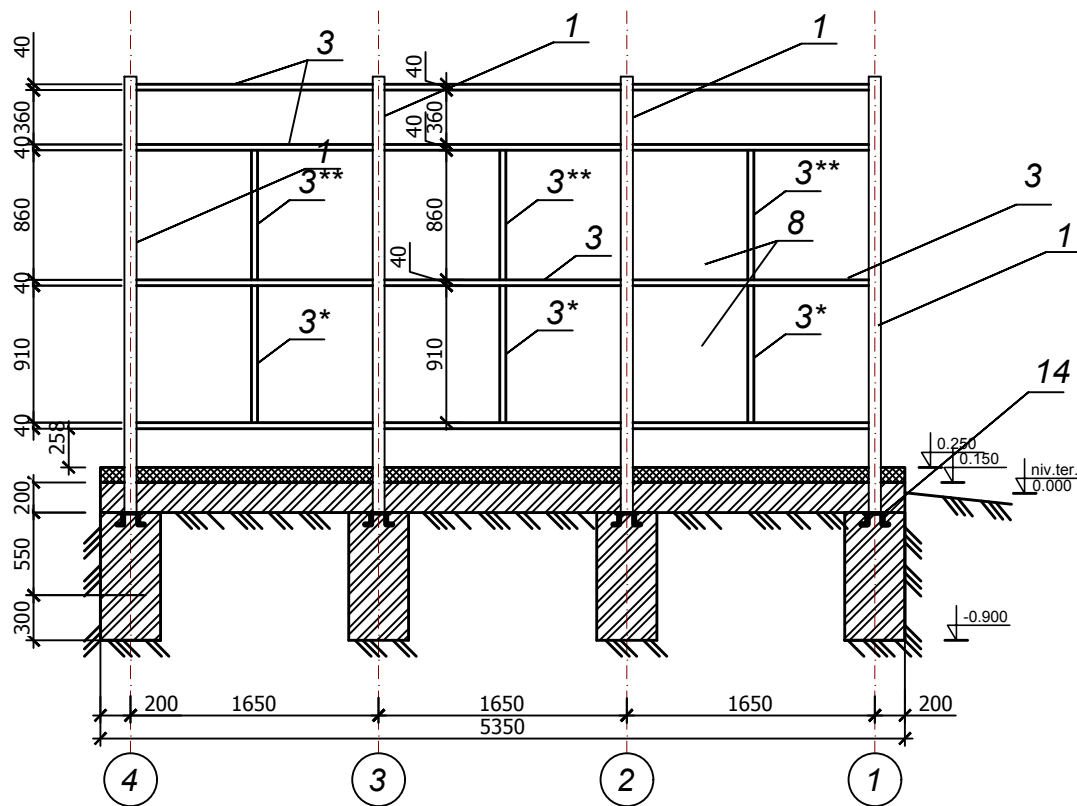

Specificatia elementelor copertinei

Poz.	Notare	Denumirea	Lung.	masa kg/m	Cant	masa toata kg
1	ГОСТ 8645-68	Teava patrata 80x80x5	2,9	11,8	6	205,3
2	ГОСТ 8645-68	Teava patrata 80x80x5	2,97	11,8	3	105,1
3	ГОСТ 8645-68	Teava patrata 40x40x3	1,57	3,5	12	65,9
3*	ГОСТ 8645-68	Teava patrata 40x40x3	0,86	3,5	5	15,1
3**	ГОСТ 8645-68	Teava patrata 40x40x3	0,91	3,5	5	15,9
4	ГОСТ 8645-68	Teava patrata 40x40x3	1,27	3,5	8	35,6
5	ГОСТ 8645-68	Teava patrata 40x40x3	0,22	3,5	8	6,2
6	ГОСТ 8645-68	Teava patrata 40x40x3	2,8	3,5	4	39,2
7	ГОСТ 30245-2003	teava dreptunghiulara 40x20x3	5,7	1,7	10	96,9
8		Tabla cutata t=0,05mm vopsita			35m.p.	
9	ГОСТ5781-82*	Ø12AIII	1	0,888	108	116,0
Et	ГОСТ5781-82*	Ø6AI	1	0,222	143	31,6
10	ГОСТ 8645-68	Teava patrata 40x40x3	0,6	3,5	4	8,4
11	ГОСТ 8645-68	Teava patrata 40x40x3	0,4	3,5	4	5,6
12	ГОСТ 8645-68	Sipci de lemn 50x50	5,03		6	0,075
13	ГОСТ 8645-68	Teava patrata 80x80x5	4,87	11,8	3	172,4
14	Серия 3.400-6/76	Piesa inglobata MH1-24		2,3	8	18,4
		Bordura din beton 100x50x500l			65	
		Stilpi din beton C 12,5 m.c.			0,7	
		Centura din beton C 12,5 m.c.			0,8	
		straturile 1.Pavaj pietonal 60mm 2.Nisip cu ciment 100mm 3. pietris copactat 100mm			18m.p.	

Nota:

1. Sudura se va executa cu electroade Э42А dupa ГОСТ 9457-65.
2. Grosimea cordonului de sudura sa fie identic grosimei elementului sudat
3. Toate elementele metalice se vopsesc de 2ori cu email ПФ115 ГОСТ 6465-76 pe un strat de grunduire ГФ-021 ГОСТ 25219-87.
4. Protectie anticorrosiva se executa conform СНиП 30403-85 "Защита строительных конструкций и сооружений от коррозии".
5. Executarea lucrarilor sa corespunda cerintelor СНиП III-4-80* "Техника безопасности в строительстве".
6. De prevazut 6 scaune de plastic fixate pe carcasul metalic .

		003/2020-SP		
		"Reconstructia si reparatia capitala a statiilor de asteptare din str. Costiujeni, or. Codru"		
		Statie de asteptare		Foi
		SP	4	
ISP		Desfasuratele axelor 1 si C		SRL "GazMolProiect"
Elaborat	Veverita S			Chişinău 2019