

Overview

Accumulation of dirt and debris on the motion system components will cause uneven or rough engraving, loss of engraving position and premature failure. Accumulation of smoke or dirt on optics can result in loss of laser power and premature failure. It is important to keep your laser system as clean as possible to ensure trouble free operation and best results from laser processing. Always turn the laser engraving system OFF and unplug it before performing any cleaning procedures.

Text

Motion System Components Diagram

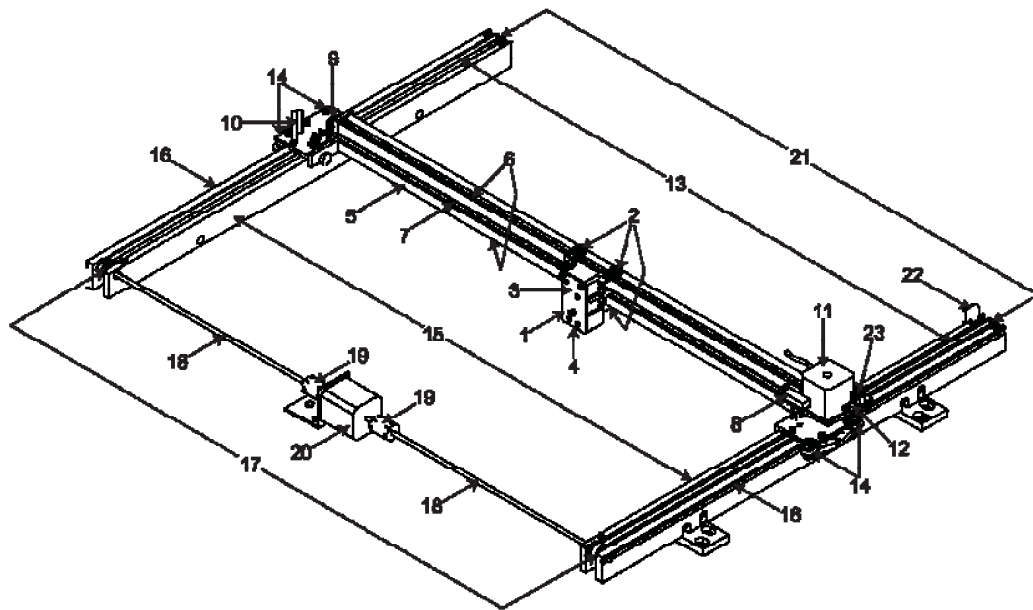

Note: #2 Mirror Cover and X-Axis Motor Cover have been removed for visibility.

- | | | |
|------------------------------------|--|---|
| 1. Focus carriage | 10. #2 mirror | 18. Y-Axis shaft (2) (one on right side, one on left side) |
| 2. X-Axis bearing (3) | 11. X-Axis motor and drive gear | 19. Y-Axis shaft flex coupler (one on right side, one on left side) |
| 3. #3 mirror (inside cover plate) | 12. X-Y home sensor board (upper flex board) | 20. Y-Axis motor |
| 4. Focus lens (inside cover plate) | 13. Y-Axis belt (2) | 21. Y-Axis idler pulley (2) (one on right side, one on left side) |
| 5. X-Axis rail (arm) | 14. Y-Axis bearing (4) (2 on right side Y-Axis rail, 2 on left side Y-Axis rail) | 22. Y-Axis home sensor flag |
| 6. X-Axis bearing track (2) | 15. Y-Axis rail (2)(one right side and one left side) | 23. Flex cable (not shown) |
| 7. X-Axis belt | 16. Y-Axis rail bearing track (2) (one on right side, one on left side) | |
| 8. X-Axis home sensor flag | 17. Y-Axis drive gear (2) (one on right side, one on the left side) | |
| 9. X-Axis idler pulley | | |

3. Tilt the front cover enough to enable you to apply the lens cleaning solution directly to the #3 mirror and to the focus lens.
4. Flood the reflective surface of the #3 mirror with the solution. If heavy debris is present, let the solution soak in for a minute.
5. Roll a fresh cotton swab across the mirror in one direction. Use a fresh swab for each pass. Be gentle when cleaning the optic to avoid scratching the surface. Repeat this procedure for the focus lens, but make sure you clean both sides of the lens.

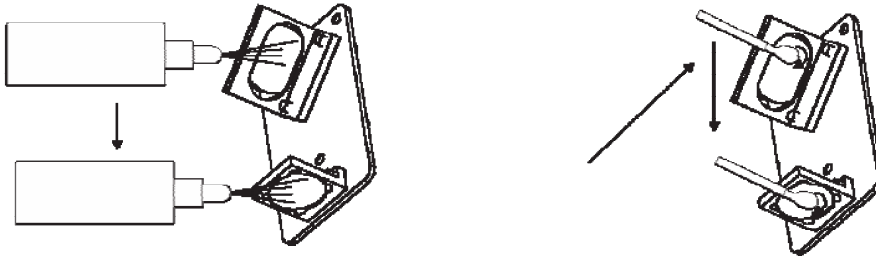

Beam Window or Collimator

The beam window or collimator is where the laser beam enters into the processing area. It is located in the upper left hand corner of the engraving area against the back wall and is yellow in color. It is only necessary to clean the front side of the beam window. Do not remove the optic to clean it; simply clean it in the same manner as the #2 mirror.

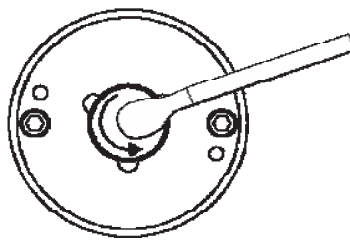

Note: If your system is equipped with Air Assist, you must remove the optics protection housing to gain access to the optic to clean it. Rotate the beam window cover counter-clockwise (2) and then off at a 45-degree angle (3). If the beam window cover is stuck, use a 1/16 Allen wrench to slightly loosen the screw (1) and try again. Set the cover off to the side and clean the optic, if necessary. Reinstall the beam window cover being careful not to scratch the optic.

