

Part No.	Description	Part No.	Description
68-3.01/02	Cover plate	6D	Fluid priming and venting
801	Flanged motor	8B	Leakage drain

Variant with clamped casing cover

[Supplied in packaging units only]

This view applies to the following pump sizes:

32-32-160 40-40-160 **50-50-160** 65-65-160 80-80-160 100-100-125 125-125-160 150-150-200
 100-100-160 125-125-200
 100-100-200

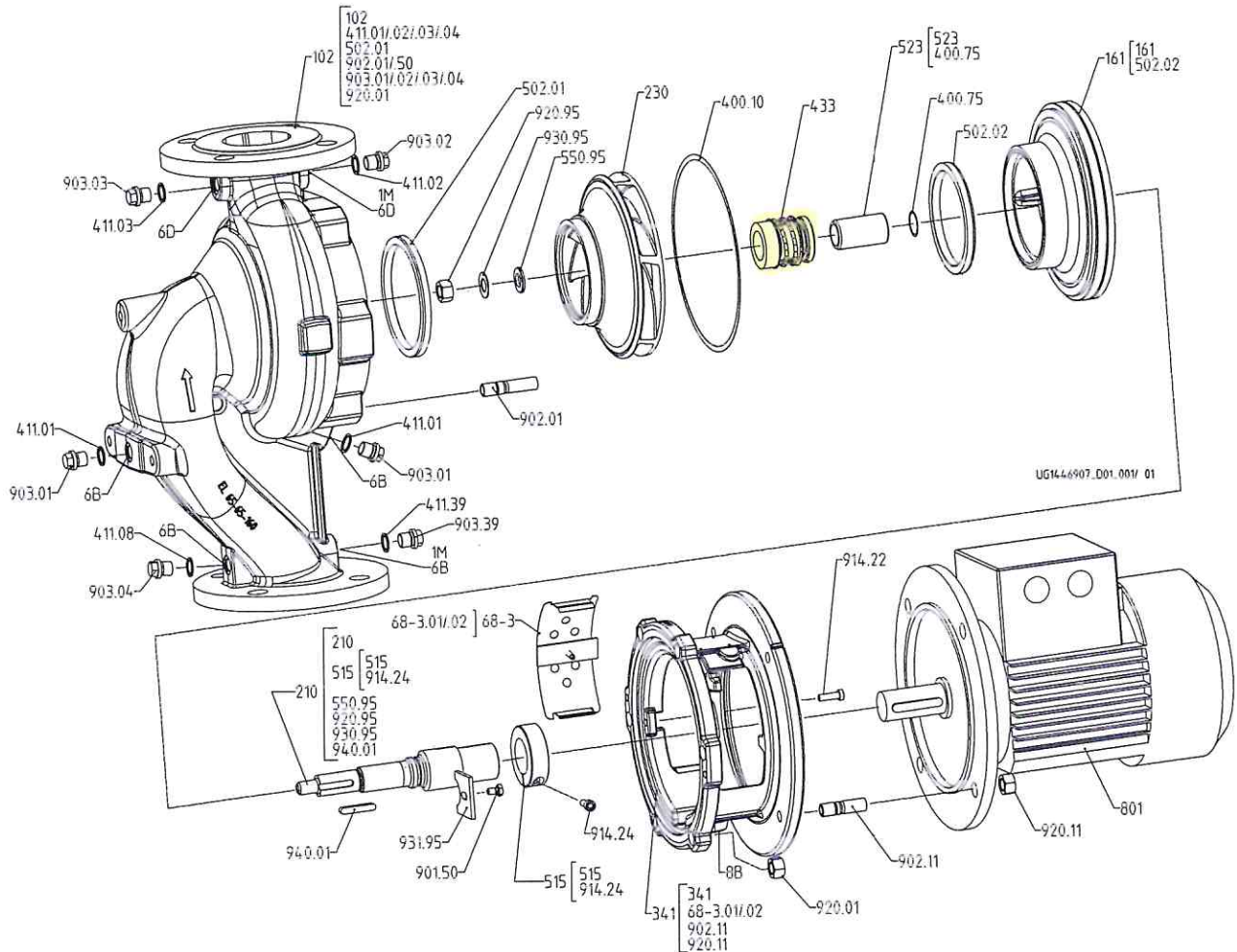

Pump set with single mechanical seal and clamped casing cover

List of components

Part No.	Description	Part No.	Description
102	Volute casing	901.50	Hexagon head bolt
161	Casing cover	902.01/11/50	Stud
210	Shaft	903.01/02/03/04/08/39	Screw plug
230	Impeller	914.22/24	Hexagon socket head cap screw
341	Drive lantern	920.01/11/95	Hexagon nut
400.10/75	Gasket	930.95	Safety device
411.01/02/03/04/08/39	O-ring	931.95	Lock washer
433	Mechanical seal	940.01	Key

25) For shaft unit 25 only