

Grosimea blatului  
din Quartz 20 mm

**La confectionarea cabinetului se va folosi doar  
Inox AISI 304, culoarea se coordoneaza cu  
beneficiarul**

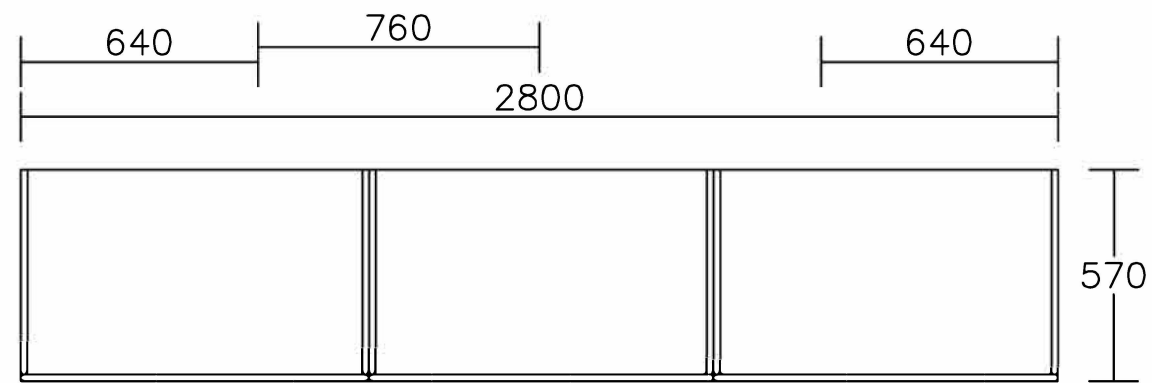
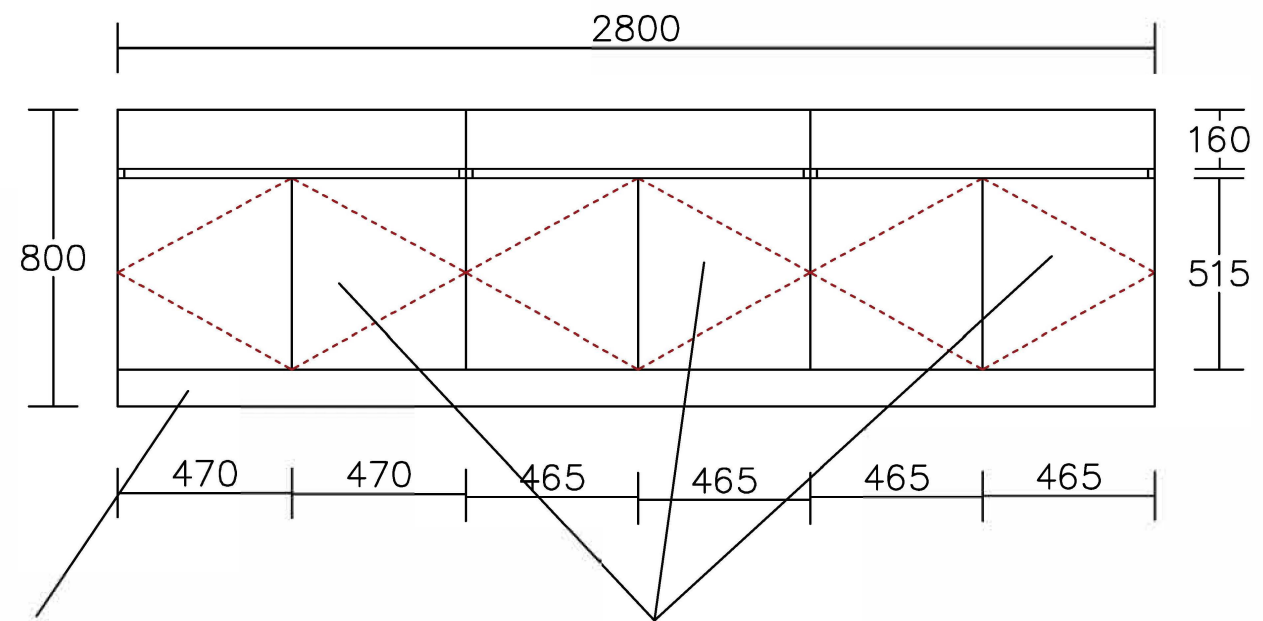
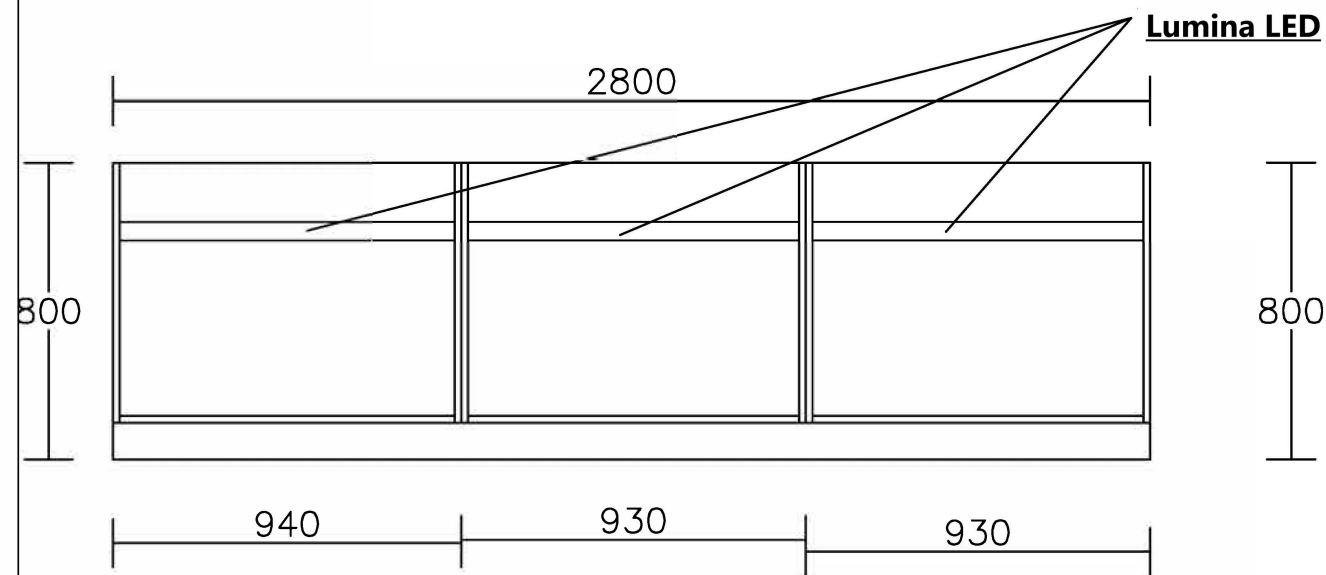

**Usi dotate cu lacat cu cod**

**Dimensiunile fixe, se vor stabili la fata locului**

## Robinet tip Dyson Airblade 2 in 1



## FRONT ELEVATION

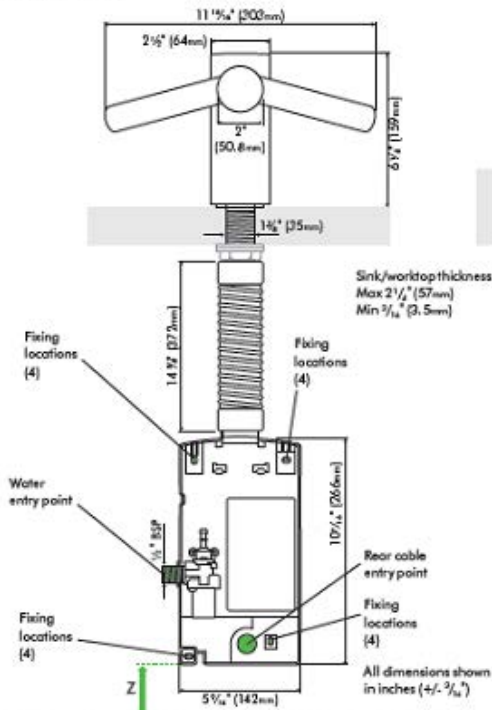

## SIDE ELEVATION

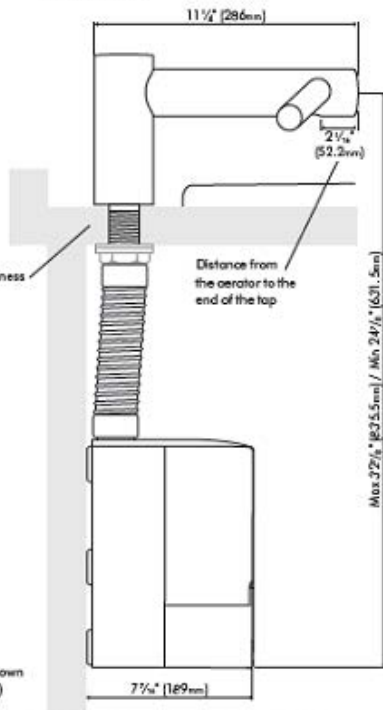

FLOOR

## Tap dimensions

WD04: Height 6 1/2" (159mm), Width 11 1/4" (293mm), Depth 11 1/2" (286mm)

## Motor bucket dimensions

WD04: Height 10 1/4" (266mm), Width 5 1/2" (142mm), Depth 7 1/2" (189mm)

## Minimum clearance

Z 4" (100mm) clearance from floor. ADA requires 9" (228mm) toe clearance.