

Knee

Next Generation in Repair
and Reconstruction



Helping Surgeons Treat Their Patients Better™

Since its inception, Arthrex has been committed to one mission: Helping Surgeons Treat Their Patients Better™. We are strategically focused on constant product innovation through scientific research, surgeon collaboration and medical education to make less invasive surgical procedures simple, safe and reproducible. Each year, we develop more than 1,000 new innovative products and procedures to advance minimally invasive orthopedics worldwide.

Arthrex has always remained a privately-held company, which allows for the rapid evaluation of new technologies and ideas. Our economic strength enables us to develop products and techniques that truly make a difference without compromising on quality. Our experienced team of dedicated professionals represents a shared passion and commitment to delivering uncompromising quality to the health care providers who use our products and the millions of patients whose lives we impact.

The medical significance of our contributions serves as our primary benchmark of success and will continue into the future as the legacy of Arthrex.

Table of Contents

Patient Positioning.....	05
ACL Reconstruction.....	09
Tunnel and Socket Preparation and Drilling.....	13
ACL / PCL Accessories.....	23
Graft Harvesting.....	27
FiberWire® Suture.....	33
Graft Prep, Sizing, and Pretensioning.....	39
Graft Fixation.....	43
Screw Insertion and Removal.....	57
PCL Reconstruction.....	61
Collateral Ligament Reconstruction and Repair.....	65
Patellofemoral Procedures.....	69
Meniscal Repair.....	75
Meniscectomy Hand Instruments.....	83
Osteochondral Repair.....	87
Osteochondral Transplant.....	93
Osteotomies.....	97
Fracture Management.....	107

Patient Positioning

PivotPost.....	07
Low-Profile Leg Holders	07

PivotPost



The PivotPost is a limb positioner with a lateral post that moves in 3 planes (rotation, in / out, up / down) to easily place the patient in the proper position and to pivot out of the way when not in use. The unique over-the-top sweeping design prevents the patient's leg from moving over the post when valgus stress or a figure 4 is applied. The small size and minimal weight makes set-up simple and allows surgeons to operate around it easily.

Product Description	Item Number
PivotPost	AR-1560
Knee post only	AR-1560-02
Clark rail adapter only	AR-1560-03
Foam pads, box of 5	AR-1560-01

Low-profile Leg Holders



The low-profile leg holder with its Velcro fastener for integration of pressure tourniquets or foam inserts provides maximum patient safety while still allowing adaptation of the thigh circumference.

Product Description	Item Number
Leg holder, with Velcro fastener	AR-1500G*
Foam cushion insert, for AR-1500G, qty. 5	AR-1502
Replacement buckle	AR-1500B
Replacement Velcro fastener	AR-1500-10
Sterile drape, for tourniquet, qty. 580	582540 83719

* Post is compatible with standard rail adapters

The previous generation, the universal leg holder, offers various leg and foot positioners for use in arthroscopic, traumatologic, and prosthetic surgical procedures.

Product Description	Item Number
Universal leg holder	AR-1520
Cushion insert, qty. 3	AR-1521

ACL Reconstruction

ACL Toolbox Instrumentation Set.....	10
--------------------------------------	----

ACL Toolbox Instrumentation Set



The ACL toolbox fits the needs of most modern ACL reconstructions. The streamlined, 3-layer case contains all the reusable instruments necessary for completing most common ACLR procedures and includes an open “pin mat” area for additional instruments. The toolbox contains the RetroConstruction drill guide set with commonly used ACL marking hooks. Multiple drill sleeves are included for all techniques and can be used with standard 2.4 mm pins, 3 mm RetroDrill pins, and 3.5 mm FlipCutter reamers.

ACL Toolbox (AR-1900S)

Product Description	Item Number
Hook probe, 3.4 mm tip, with 5 mm markings	AR-10010
RetroConstruction™ handle, side release	AR-1510HR
Drill sleeve, for side-release handle, ratcheting, 2.4 mm	AR-1510FD-24
Drill sleeve, for side-release handle, ratcheting, 3 mm	AR-1510FD-30
Drill sleeve, for FlipCutter®, ratcheting, 3.5 mm	AR-1510FD-35
Drill sleeve, for RetroConstruction™ drill guide, stepped, 7 mm long tip	AR-1204FDS
Drill sleeve, for RetroConstruction™ drill guide, stepped, 10 mm long tip	AR-1204FDS-10
Stepped drill sleeve, for side-release handle, ratcheting	AR-1510FS-7
Drill, cannulated, 8 mm	AR-1208L
Drill, cannulated, 9 mm	AR-1209L
Drill, cannulated, 10 mm	AR-1214L
Drill, cannulated, 11 mm	AR-1217L*
Drill, cannulated, 15 mm	AR-1215L*
Parallel guide sleeve, 2.4 mm pins	AR-1245L
Offset drill guide, 3.5 mm	AR-1246-1
Offset drill guide pin, 3.5 mm	AR-1246-3
Tunnel plug, for 8 to 12 mm drill holes	AR-1258
Semitendinosus stripper, 7 mm	AR-1278L
Pigtail hamstring tendon stripper, open end, 5 mm	AR-1278P
Graft harvester, minimally invasive, open, 7 mm	AR-1278PL
Tunnel / notchplasty rasp	AR-1282
Headed reamers, cannulated, 8 - 11 mm	AR-1408 to AR-1411
Reamer handle and pin puller	AR-1415
Graft harvesting retractor	AR-1420
Femoral ACL marking hook, curved	AR-1510F-01
Footprint femoral ACL guide, left	AR-1510FL
Footprint femoral ACL guide, right	AR-1510FR
Tibial ACL marking hook, for RetroConstruction™ drill guide	AR-1510T
Footprint tibial ACL marking hook, for RetroConstruction™ drill guide, left	AR-1510TL
Footprint tibial ACL marking hook, for RetroConstruction™ drill guide, right	AR-1510TR
RetroScrew® driver, thin	AR-1586R
Guide pin sleeve, 2.4 mm	AR-1204F-24I
Obturator, 3.5 mm	AR-1204F-OB
Transportal ACL guide, 6 mm offset	AR-1800-06
Transportal ACL guide, 7 mm offset	AR-1800-07
Obturator, reusable	AR-1807
Transtibial femoral ACL drill guide, 7 mm	AR-1801
Transtibial femoral ACL drill guide, 6 mm	AR-1804
Graft harvesting cutting guides, 8.5 mm	AR-1809
Graft harvesting cutting guides, 9.5 mm,	AR-1810
Graft harvesting cutting guides, 10.5 mm	AR-1811
Notchplasty and graft harvesting osteotome, 5 mm	AR-1830
Tunnel notcher	AR-1844
Graft sizing block, 4.5 - 12 mm holes (0.5 mm increments)	AR-1886

* Not included in set. Order separately.

ACL Toolbox (Cont)

Product Description	Item Number
BioComposite interference screwdriver, quick connect	AR-1996CD-1
Screwdriver shaft, cannulated, for delta bio-interference screw	AR-1997D
Screwdriver shaft, cannulated, 3.5 mm hex, Ø 5.5 mm × 17 cm	AR-1998
BioComposite interference screw taps, 7 - 10 mm, quick connect	AR-1998CT-07 – 10
Screwdriver handle, ratcheting	AR-1999
Parallel graft knife handle	AR-2285H
Chuck key	AR-8241
ACL cruciate toolbox instrumentation case	AR-1900C

Optional

Product Description	Item Number
Drill tip guide pin, 3.5 mm (predrill pin for FlipCutter® reamer)	AR-1250F
Tibial ACL drill guide, pin tip	AR-1510GT
Universal instrument case	AR-1817C

Tunnel and Socket Preparation and Drilling

FlipCutter® III Drill.....	14
RetroConstruction™ Drill Guide Set.....	15
Transportal ACL Guides.....	16
Transtibial Femoral Guides.....	16
Low-Profile Reamers.....	17
Cannulated Headed Reamers	17
Flexible Reamers for ACL Reconstruction	18
TransFix® II Femoral Drill Guide	18
Cannulated and Sterile Cannulated Drill	19
Coring Reamers	19
Tunnel Dilators.....	20
Notchplasty	21

FlipCutter® III Drill



The new, innovative FlipCutter III drill is an adjustable, variable-size, all-in-1 guide pin and reamer that allows minimally invasive inside-out socket creation. Arthrex's proprietary FlipCutter technology allows unconstrained freedom of socket positioning and is ideal for difficult-to-reach applications such as tibial socket creation for PCL reconstruction, anatomic femoral socket creation for ACL reconstruction, and socket creation for meniscal allograft transplantation or meniscal root repair. This single device drills size 6 mm and sizes 7 to 12 mm, including half sizes.

Product Description	Item Number
FlipCutter® III drill, 6 - 12 mm (including half sizes, except 6.5 mm)	AR-1204FF

The short FlipCutter II reamer decreases the distance surgeons must reach while drilling, enabling more control and accuracy. Together with the side-release RetroConstruction handle, the short FlipCutter II reamer makes anatomic, minimally-invasive drilling easier than ever.

Product Description	Item Number
FlipCutter® II, short, 5 - 13 mm Diameter: 5, 5.5, 6, 6.5, 7, 7.5, 8, 8.5, 9, 9.5, 10, 10.5, 11, 11.5, 12, 13 mm	AR-1204AS-50 to -130
FlipCutter® II, 6 - 13 mm Diameter: 5, 5.5, 6, 6.5, 7, 7.5, 8, 8.5, 9, 9.5, 10, 10.5, 11, 11.5, 12, 13 mm	AR-1204AF-60 to -130

RetroConstruction™ Drill Guide Set



The small, easy-to-use RetroConstruction drill guide set accommodates up to 14 marking hook options for multiple applications. The adjustable C-ring allows several drilling angles without sacrificing accuracy. Multiple drill sleeves accommodate retrograde reaming with the FlipCutter reamer and antegrade reaming with standard 2.4 mm pins. The additional stepped drill sleeve acts as a depth stop for retrograde drilling and maintains joint access during reamer removal for insertion of graft-passing sutures.

RetroConstruction™ Drill Guide Set (AR-1510S)

Product Description	Item Number
RetroConstruction™ drill guide handle	AR-1510H
RetroConstruction™ drill guide handle, side release	AR-1510HR
Drill sleeve, for RetroConstruction™ drill guide, 3.5 mm	AR-1510D
Drill sleeve, for RetroConstruction™ drill guide, 2.4 mm	AR-1778R-24
Drill sleeve, for RetroConstruction™ drill guide, 3 mm	AR-1778R-30
Drill sleeve, for RetroConstruction™ drill guide, stepped, 7 mm long tip	AR-1204FDS
Drill sleeve, for RetroConstruction™ drill guide, stepped, 10 mm long tip	AR-1204FDS-10
FlipCutter® drill sleeve, ratcheting, stepped, 3.5 mm	AR-1510FS-7
Drill sleeve, ratcheting, 2.4 mm	AR-1510FD-24
Drill sleeve, ratcheting, 3 mm	AR-1510FD-30
Drill sleeve, ratcheting, 3.5 mm	AR-1510FD-35
Obturator, 3.5 mm	AR-1204F-OB
Guide pin sleeve, 2.4 mm	AR-1204F-24I
Tibial ACL marking hook, for RetroConstruction™ drill guide	AR-1510T
Tibial ACL marking hook, blunt preservative, right	AR-1510TR
Tibial ACL marking hook, blunt preservative, left	AR-1510TL
Femoral ACL marking hook, for RetroConstruction™ drill guide	AR-1510F
Femoral ACL marking hook, curved	AR-1510F-01
PCL tibial marking hook, for RetroConstruction™ drill guide	AR-1510PT
Femoral PCL marking hook, for RetroConstruction™ drill guide	AR-1510PF
Reusable marking hook, for RetroConstruction™ drill guide	AR-1510M
Popliteus marking hook, tibia	AR-1510PT-1
RetroConstruction™ drill guide system case	AR-1510C

Accessories

Product Description	Item Number
Guide pin, with drill thread, 3.5 mm (predrill pin for FlipCutter®)	AR-1250F
Tibial ACL drill guide, pin tip	AR-1510GT
Tibial ACL marking hook, with guide pin, small angle	AR-1510GTS
Femoral ACL footprint drill guide, left	AR-1510FL
Femoral ACL footprint drill guide, right (a)	AR-1510FR
Femoral ACL footprint drill guide, with 7 mm offset, left	AR-1510FPL
Femoral ACL footprint drill guide, with 7 mm offset, right	AR-1510FPR
Femoral ACL footprint drill guide, small angle, left	AR-1510FLS
Femoral ACL footprint drill guide, small angle, right	AR-1510FRS
Femoral ACL hook, for outside-in technique	SP-1510F-02
Femoral RetroConstruction™ drill guide, AM portal, left	AR-1510FL-01
Femoral ACL RetroConstruction™ drill guide, AM portal, right	AR-1510FR-01
Anatomic contour PCL guide, left	AR-1510PTL
Anatomic contour PCL guide, right	AR-1510PTR
Popliteus marking hook, tibia	AR-1510PT-1

Transportal ACL Guides



The transportal ACL guides (TPGs) were designed specifically for the anteromedial portal approach and allow surgeons freedom in femoral socket placement, while maintaining appropriate back wall thickness. The open-angled offset tip allows reproducible back wall thickness and facilitates anterior trajectory of the guide pin. The longer tip stabilizes the guide over the posterior cortex during hyperflexion.

Product Description	Item Number
Transportal ACL guide, 4 - 8 mm Offset: 4, 5, 6, 7, 8 mm	AR-1800-04 to -08

Transtibial Femoral Guides



The transtibial femoral ACL drill guides allow precise placement of femoral tunnels by referencing the over-the-top position. Five sizes (4, 5, 6, 7, and 8 mm offsets) create a 1 - 2 mm tunnel back wall when used with an appropriately sized drill.

Product Description	Item Number
Transtibial femoral ACL drill guide, 4 mm, for 6 - 7 mm tunnels	AR-1806
Transtibial femoral ACL drill guide, 5 mm, for 7 - 8 mm tunnels	AR-1803
Transtibial femoral ACL drill guide, 6 mm	AR-1804
Transtibial femoral ACL drill guide, 7 mm	AR-1801
Transtibial femoral ACL drill guide, 8 mm, for 10 - 11 mm tunnels	AR-1805

Guide pin available sterile in the transtibial ACL disposables kit

Low-Profile Reamers

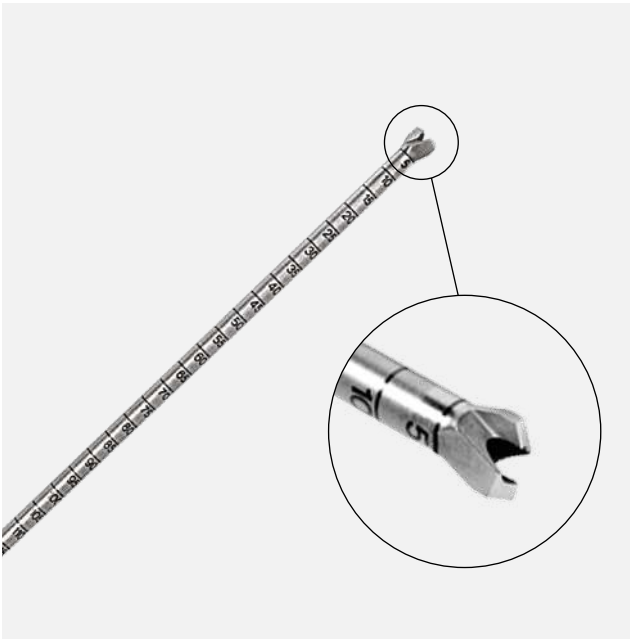

Low profile headed reamers facilitate femoral tunnel preparation through the medial portal and also allow greater positioning flexibility. The drill's extra thin shaft and "2-flute" design provides a flat profile that easily passes through the portal and avoids damaging the femoral condyle and PCL.

Product Description	Item Number
Headed reamers, low profile, 5 - 13 mm Diameter: 5, 6, 7, 8, 9, 10, 11, 12, 13 mm	AR-1405LP to -1413LP
Headed reamers, low profile, 5.5 - 12.5 mm Diameter: 5.5, 6.5, 7.5, 8.5, 9.5, 10.5, 11.5, 12.5 mm	AR-1405LP-50 to -1412LP-50

Cannulated Headed Reamers

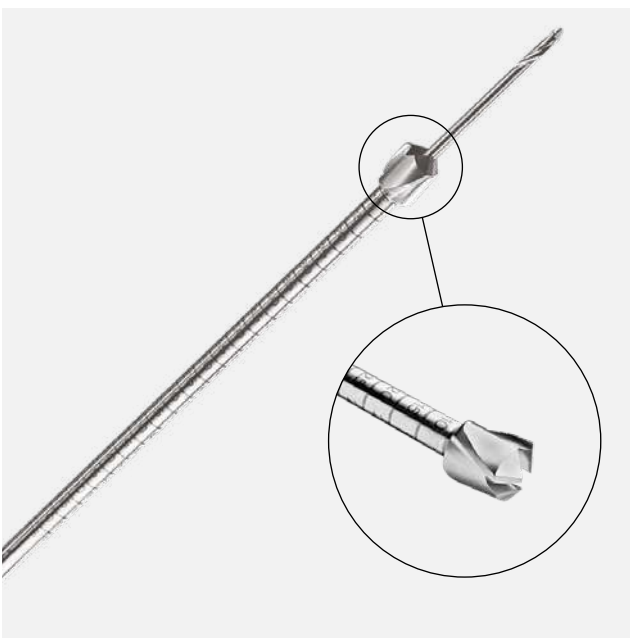

The cannulated headed reamers allow the femoral tunnel to be created via the medial portal. The sharp, easy-penetrating reamer design has rounded back edges that help protect the PCL. Markings in 5 mm increments provide precise depth control.

Product Description	Item Number
Headed reamers, low profile, 5 - 13 mm Diameter: 5, 6, 7, 8, 9, 10, 11, 12, 13 mm	AR-1405 to -1414
Headed reamers, low profile, 5.5 - 12.5 mm Diameter: 5.5, 6.5, 7.5, 8.5, 9.5, 10.5, 11.5, 12.5 mm	AR-1405.5 to -1410.5

Guide pin available sterile in the transtibial ACL disposables kit

Flexible Reamers for ACL Reconstruction

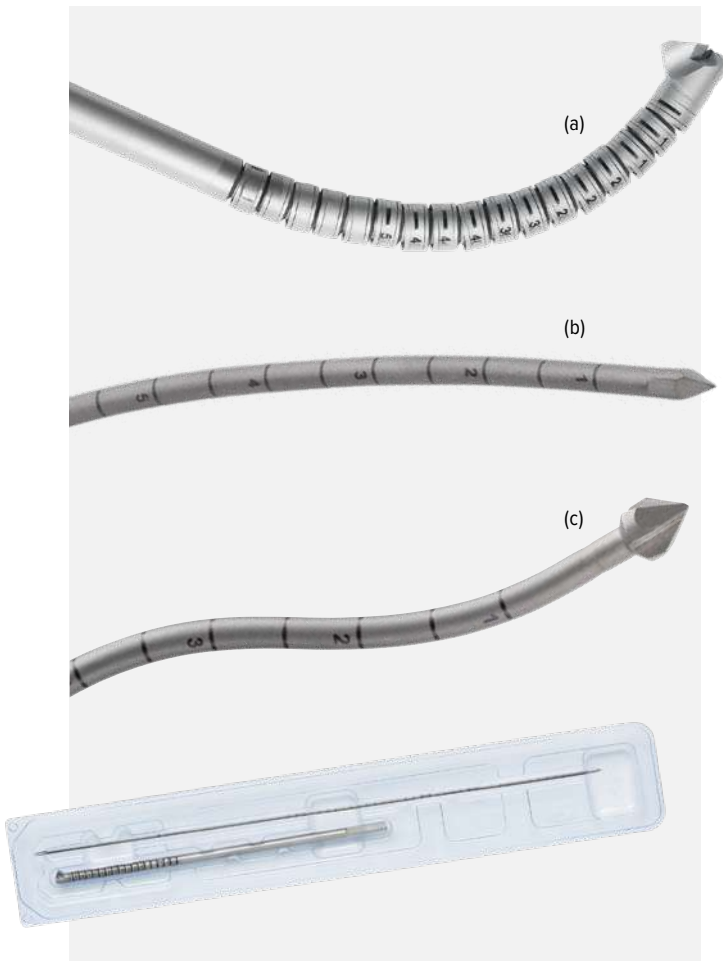

The flexible reamer system facilitates reproducible femoral socket creation from the medial portal without hyperflexion of the knee. An innovative, flexible-link design allows unmatched flexibility with increased strength over standard “puzzle piece” designs. The adjustable curved guide, flexible guide pins, and screwdrivers give surgeons more versatility in socket placement and graft fixation options.

Flexible Reamer Kits

Product Description	Item Number
Reamer, flexible (a), with flexible guide pin (b), 7 - 11 mm Diameter: 7, 7.5, 8, 8.5, 9, 9.5, 10, 10.5, 11 mm	AR-1400F-70 to -110
Reamer, flexible (a), with flexible TightRope® pin (c), 7 - 10 mm Diameter: 7, 7.5, 8, 8.5, 9, 9.5, 10 mm	AR-1401F-70 to -110
Reusable Instruments	
Screw tap, flexible, 7 - 10 mm Diameter: 7, 8, 9, 10 mm	AR-1998CTF-07 to -10
Screwdriver shaft, for 23 mm BioComposite and PEEK screws, flexible	AR-1996FD-1
Drill guide, for flexible guide pins, curved	AR-1800F
Pin puller	AR-1298P
Flexible Guide Pins Without Reamer	
Guide pin, for flexible reamer, 2.4 mm	AR-1400FLX
Flexible TightRope® drill pin, for flexible reamer (c)	AR-1298FLX

TransFix® II Femoral Drill Guide



This femoral guide facilitates TransFix implantation for transtibial ACL reconstruction. The TransFix II ACL reconstruction instrumentation set comes with all the required TransFix II instrumentation.

TransFix® II Sets

Product Description	Item Number
TransFix® II ACL reconstruction instrumentation set	AR-1817TS
TransFix® II drill set	AR-1978S

Cannulated and Sterile Cannulated Drill



Full-thickness cannulated drills with graduated depth marks are designed specifically for ACL tibial tunnels, PCL tibial and femoral tunnels, and standard 2-incision ACL reconstruction procedures. The optional drill sleeves help protect soft tissue during drilling.

Product Description	Item Number
Reusable Cannulated Drills	
Drill, cannulated, 4 mm	AR-1204L
Drill, cannulated, 5 mm	AR-1205L
Drill, cannulated, 6 mm	AR-1206L
Drill sleeve, cannulated, 6 mm	AR-1206S
Drill, cannulated, 7 mm	AR-1207L
Drill sleeve, cannulated, 7 mm	AR-1207S
Drill, cannulated, 8 mm	AR-1208L
Drill sleeve, cannulated, 8 mm	AR-1208S
Drill, cannulated, 9 mm	AR-1209L
Drill sleeve, cannulated, 9 mm	AR-1209S
Drill, cannulated, 10 mm	AR-1214L
Drill sleeve, cannulated, 10 mm	AR-1214S
Drill, cannulated, 11 mm	AR-1217L
Drill sleeve, cannulated, 11 mm	AR-1217S
Drill, cannulated, 12 mm	AR-1221L
Drill sleeve, cannulated, 12 mm	AR-1221S
Drill, cannulated, 15 mm	AR-1215L
Drill sleeve, cannulated, 15 mm	AR-1215S
Guide pin, with drill thread, 2.4 mm, qty. 6	AR-1250L-1
Sterile Cannulated Drills	
Drill, cannulated, 4 - 15 mm, sterile Diameter: 4, 4.5, 5, 5.5, 6, 6.5, 7, 7.5, 8, 8.5, 9, 9.5, 10, 10.5, 11, 11.5, 12, 15 mm	AR-1218-40 to -150

Coring Reamers



The coring reamers are available in various diameters and are used for tunnel and socket drilling in the tibia. In this way, a graft plug is removed and space created for cruciate reconstruction. The removed bone can be used to fill any remaining harvesting defects in the tibia, patella, or femur.

Coring Reamer Sets

Product Description	Item Number
Coring reamer and collared pin set, 7 mm	AR-1220S
Coring reamer and collared pin set, 8 mm	AR-1222S
Coring reamer and collared pin set, 9 mm	AR-1223S
Coring reamer and collared pin set, 10 mm	AR-1224S
Coring reamer and collared pin set, 11 mm	AR-1226S
Coring reamer and collared pin set, 12 mm	AR-1227S
Coring reamer and collared pin set, 13 mm	AR-1229S
Coring reamer and collared pin set, 14 mm	AR-1231S
Reusable Instrument	
Graft extractor, for coring reamer	AR-1232

Tunnel Dilators



The cannulated tunnel dilators improve the fixation of the soft tissue graft by compressing the cancellous bone to the drilled femoral or tibial tunnel wall. The dilators are available in sizes from 5.5 to 12 mm. The Hudson quick connect T-handle is easy to connect to the dilators and allows a quick change from one size to the next.

ACL Tunnel Preparation Instrumentation Set (AR-1856S)

Product Description	Item Number
T-handle, Hudson, quick connect	AR-1416T
ACL reaming instrumentation set	AR-1856C
Tunnel dilators, 5.5 - 12 mm (0.5 mm increments)	AR-1854-05.5 to -12.0

Notchplasty



The curved tunnel / notchplasty rasp is ideal for completing the notchplasty and chamfering of the tibial and femoral tunnel rim. Designed specifically for rasping or smoothing tunnel rims after drilling to reduce graft abrasion or laceration, the rasp fits easily through the tibial tunnel cannula in an 8 mm tunnel. The offset shaft of the notchplasty osteotome provides easy access to the lateral wall of the intercondylar notch from the antero-medial portal for anatomical widening of the notch. The open ring curette, which is sharp on both sides, will help to perform the soft-tissue notchplasty to identify the over-the-top position.

Product Description	Item Number
Tunnel / notchplasty rasp (a)	AR-1282
Notchplasty and graft harvesting osteotome, 5 mm (b)	AR-1830
Ring curette, 5.4 mm, one side cut (c)	AR-20010
Ring curette, 5.4 mm, both sides cut	AR-20020

ACL / PCL Accessories

ACL Disposables Kits	24
ACL / PCL Graft-Passing Forceps	25

ACL Disposables Kits



The single-use transtibial ACL disposables kits provide a convenient and sterile, complete set of all the guide pins and disposables required for an ACL reconstruction.

Transtibial ACL Disposables Kit
With Hall-Style Saw Blade (a),
qty. 5 (AR-1897S)

Product Description	Item Number
2.4 mm guide pin, with suture eyelet	AR-1297L
Guide pin, with drill thread, 2.4 mm, qty. 6	AR-1250L-1
Guide wire, for bio-interference screw, nitinol, 1.1 mm	AR-1249
Guide wire, nitinol, 2 mm, with 25 and 30 mm depth markings	AR-1254
Tibial tunnel cannula	AR-1802D
Backflow cap	AR-1812
Marking ruler and sterile marking pen	43-1032
Hall-style sagittal saw blade, with 7 mm depth stop	AR-1821
Graft harvesting fix drill	AR-1904

Transtibial ACL Disposables
Kit Without Saw Blade, qty. 5
(AR-1898S)

Product Description	Item Number
Guide pin, with suture eyelet, 2.4 mm	AR-1297L
Guide pin, with drill thread, 2.4 mm, qty. 6	AR-1250L-1
Guide wire, for bio-interference screws, nitinol, 1.1 mm	AR-1249
Guide wire, nitinol, 2 mm, with 25 and 30 mm depth markings	AR-1254
Tibial tunnel cannula	AR-1802D
Backflow cap	AR-1812
Marking ruler and sterile marking pen	43-1032

TransFix® II Drill Set
(AR-1978S-1)

Product Description	Item Number
Guide pin, with drill thread, 2.4 mm, qty. 6	AR-1250L-1
Graft suture-passing wire	AR-1255
TransFix® II guide pin, 3 mm	-----

ACL / PCL Graft-Passing Forceps



The ACL / PCL graft forceps are designed for atraumatic manipulation of the graft intra-articularly during graft passing. The smooth, curved jaws provide excellent rotational control of the graft during insertion into femoral tunnels and also for large loose body removal.

Product Description	Item Number
ACL / PCL graft-passing graspers, with SR handle	AR-13400SRF
ACL / PCL graft-passing graspers, with NR handle	AR-13400NRF

Graft Harvesting

QuadPro™ Tendon Harvester	28
Minimally Invasive Quad Tendon Set.....	28
Atraumatic Hamstring Harvester	29
Hamstring Tendon Strippers	29
Minimally Invasive Hamstring Harvesting Set.....	30
Graft Harvesting Cutting Guides and Saw Blades	30
Parallel Graft Knife for Patella Tendon Harvesting.....	31
Graft Harvesting Retractor.....	31
ACL Graft Shaper	31

QuadPro™ Tendon Harvester

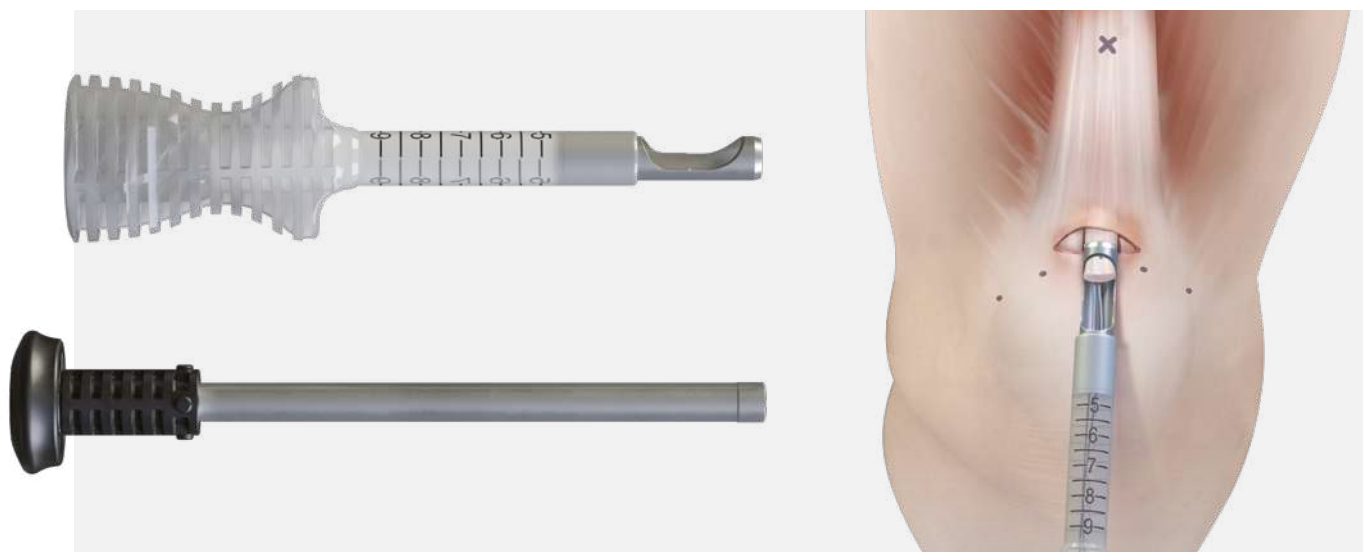

The QuadPro tendon harvester was developed from Arthrex's commitment to Helping Surgeons Treat Their Patients Better. It was specifically engineered to allow for efficient, minimally invasive graft harvesting while reducing the morbidity and challenges associated with traditional harvesting techniques.

Reproducible Graft Sizing:

- Available in various sizes for the appropriate graft diameter (8, 9, 10, and 11 mm)
- Sharp cylindrical tip harvests a round, true-to-size graft
- Clear handle with graduations to determine graft length

Minimally Invasive Technique:

- Minimal incision and dissection required
- Reduces procedure time and graft site morbidity

Graft Amputation:

- Graft retrieved through amputation window in device after harvesting
- Sharp cutting edge in window amputates graft when push rod is completely deployed

QuadPro™ Tendon Harvester Kit

Product Description	Item Number
QuadPro™ tendon harvester, 8 mm	AR-2386-08
QuadPro™ tendon harvester, 9 mm	AR-2386-09
QuadPro™ tendon harvester, 10 mm	AR-2386-10
QuadPro™ tendon harvester, 11 mm	AR-2386-11

Minimally Invasive Quad Tendon Set

The minimally invasive quad tendon harvest system allows surgeons to safely harvest a graft of a desired length and diameter through a small incision in a time-efficient manner. The system has the versatility to create grafts from soft tissue only, or from bone and soft tissue.

Minimally Invasive Quad Tendon Set (AR-2382S)

Product Description	Item Number
Quad tendon graft cutting guide	AR-2383
Quad tendon stripper / cutter (b)	AR-2384
Instrument case	AR-2382C
Disposable Blades for Quadriceps Tendon Graft Cutting Guide (a)	
Quad tendon graft cutting blade, 9 mm	AR-2385-09
Quad tendon graft cutting blade, 10 mm	AR-2385-10
Quad tendon graft cutting blade, 11 mm	AR-2385-11

Atraumatic Hamstring Harvester



The atraumatic tendon harvester facilitates minimally invasive harvesting from an anterior or posterior incision. Easily load hamstring tendons with the opening / closing tip. The smooth edge bluntly dissects the tendon away from muscle, limits the chance of premature tendon amputation, and potentially decreases patient morbidity.

Product Description	Item Number
Atraumatic hamstring harvester	AR-10300F

Hamstring Tendon Strippers



The 5 and 7 mm-diameter hamstring tendon strippers provide maximum tendon length with less soft tissue trauma through a small incision just medial to the tibial tubercle. While harvesting, use the graduations on the shaft to determine graft length. The spiral end of the “pigtail” facilitates the capture of distally attached tendons for proximal subcutaneous stripping of hamstring grafts.

Product Description	Item Number
Semitendinosus stripper, 5 mm	AR-1278
Semitendinosus stripper, 7 mm (a)	AR-1278L
Pigtail hamstring tendon stripper, open end, 5 mm (b)	AR-1278P
Pigtail hamstring tendon stripper, open end, 7 mm	AR-1278PL

Minimally Invasive Hamstring Harvesting Set



Minimally Invasive Hamstring Harvesting Set (AR-1279S)

Product Description	Item Number
Pigtail hamstring tendon stripper, open end, 5 mm diameter	AR-1278P
Pigtail hamstring tendon stripper, open end, 7 mm diameter	AR-1278PL
Hamstring harvesting instrument case	AR-1279C

This set includes 2 harvesters designed for removal of the hamstring tendons through a small, minimally invasive posteromedial incision. Shorter shafts improve stiffness and facilitate harvesting from the posteromedial incision. The open harvester is large enough to load the thicker, more proximal portion of the hamstring tendons. The closed distal harvester is slightly sharper, permitting elevation of the tendons off the tibial insertion.

Graft Harvesting Cutting Guides and Saw Blades



The cutting guides allow the removal of an ideal, trapezoid-shaped bone plug with pre-drilled suture holes from the patella and tibia. Arthrex saw blades have the ideal width and tooth configuration for BTB graft harvesting. A mechanical depth stop provides secure depth control.

Product Description	Item Number
Graft harvesting cutting guide, 8.5 mm wide	AR-1809
Graft harvesting cutting guide, 9.5 mm wide	AR-1810
Graft harvesting cutting guide, 10.5 mm wide	AR-1811
Graft harvesting kit, with Hall-style sagittal saw blade and 2 threaded fixation pins, short and long	AR-1821S
Hall-style sagittal saw blade, with 7 mm depth stop	AR-1821
Threaded fixation pins, for graft harvesting guide, 1 long and 1 short	AR-1904

Parallel Graft Knife for Patella Tendon Harvesting

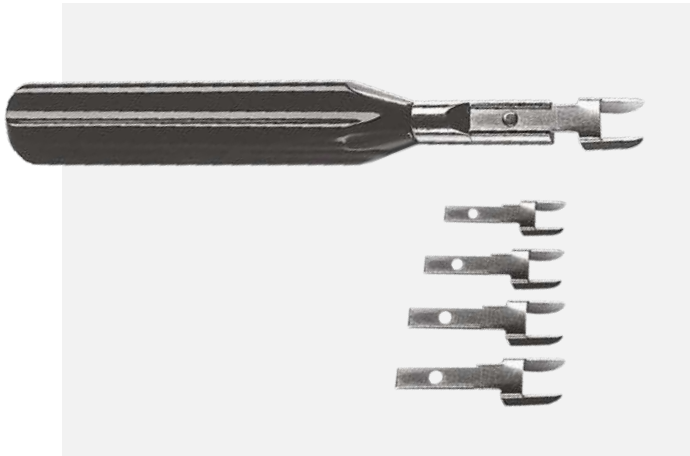

The parallel graft knife is designed for harvesting the patellar or quadriceps tendon for use during ACL / PCL reconstruction. The parallel blades create a precise and a parallel proximal-to-distal incision. It is available in sizes from 8 to 11 mm and is used with a reusable handle.

Product Description	Item Number
Parallel graft knife handle	AR-2285H
Parallel graft knife blade, 8 mm	AR-2285-08
Parallel graft knife blade, 9 mm	AR-2285-09
Parallel graft knife blade, 10 mm	AR-2285-10
Parallel graft knife blade, 11 mm	AR-2285-11

Graft-Harvesting Retractor



The BTB graft-harvesting retractor is hooked over the upper pole of the patella. This is then levered to securely retract the surrounding skin and subcutaneous tissue. The graft-harvesting retractor can also be used for the retraction of skin and soft tissue when preparing the tibial tunnel.

Product Description	Item Number
Graft-harvesting retractor	AR-1420

ACL Graft Shaper



The ACL graft shaper is a bone “press” that shapes and compresses cancellous bone to accommodate a precise graft fit into predrilled tibial or femoral tunnels during ACL / PCL reconstruction. An adjustable spacer in the handle provides controlled size compression of bone plugs to 8, 9, 10, or 11 mm diameters.

Product Description	Item Number
ACL graft shaper	AR-1234

FiberWire[®] Suture

FiberLoop [®] and TigerLoop [™]	34
FiberWire [®] Sutures With Needles	34
FiberWire [®] Sutures and SutureTape	35
FiberLink [™] and TigerLink [™]	35
FiberStick [™] and TigerStick [®]	36
FiberSnare [®] Suture	36
FiberTape [®]	37
Suture Tensioner With Tensiometer.....	37

FiberLoop® and TigerLoop™

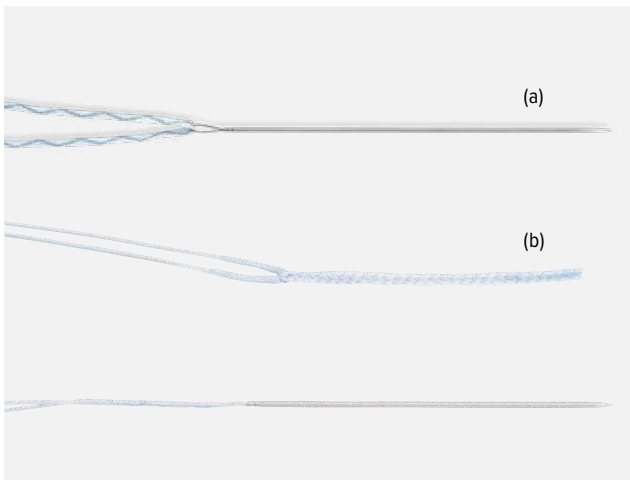

The FiberLoop and TigerLoop is a continuous loop of FiberWire on a thin, straight, nitinol needle that enables the performance of a SpeedWhip technique. Graft preparation using the SpeedWhip technique drastically reduces time spent preparing the graft, uniformly compresses the graft, improves strength, and allows adjustments of graft length. The FiberLoop and TigerLoop product line has grown to more than a dozen different options for varying surgeon preferences.

Product Description	Item Number
FiberLoop®, with 1.3 mm SutureTape suture (a)	AR-7534
TigerLoop™, with 1.3 mm SutureTape suture	AR-7534T
#2 FiberLoop®, with straight needle	AR-7234
#2 TigerLoop™, with straight needle, with TigerWire®	AR-7234T
#2 FiberLoop®, blue, 51 cm, 1/2 circle, with curved needle	AR-7234C
#2 FiberLoop®, with durable straight needle	AR-7284
#0 FiberLoop® suture, blue, 33 cm, with straight needle, 76 mm, with 7 mm loop	AR-7253
#0 TigerLoop® suture, white / green, with straight needle, 76 mm, with 7 mm loop	AR-7253T
#2-0 FiberLoop®, blue, 76.2 cm, with diamond point needle, 48 mm, 1/2 circle	AR-7232-01
#2-0 FiberLoop®, blue, 60.96 cm, with diamond point needle, 26.2 mm, 3/8 circle	AR-7232-02
#2-0 FiberLoop®, blue, 33 cm, with diamond point straight needle, 64.8 mm	AR-7232-03
FiberLoop® with FiberTag® suture, with looped straight needle	AR-7264
FiberLoop® with FiberTag® suture, with swedged-on straight needle (b)	AR-7266

FiberWire® Sutures With Needles



This product family includes various FiberWire sutures with directly attached straight or curved needles. These products are ideal for quickly creating locking Krackow stitches for graft prep and tendon avulsions in large tendons such as quadriceps or patellar tendons.

Product Description	Item Number
#2 FiberWire®, with straight needle	AR-7246
#2 FiberWire®, with 2 straight needles	AR-7246-02
#2 FiberWire®, blue, 97 cm, with tapered needle, 26.5 mm, 1/2 circle	AR-7200
#2 FiberWire®, 97 cm, 1 white / black, 1 blue, with tapered needle, 26.5 mm 1/2 circle	AR-7208
#2-0 FiberWire®, blue, 46 cm, with tapered needle, 26.5 mm, 1/2 circle	AR-7242
#2-0 FiberWire®, blue, 46 cm, with tapered needle, 17.9 mm, 3/8 circle	AR-7220
#0 FiberWire®, blue, 97 cm, with tapered needle, 22.2 mm, 1/2 circle	AR-7250
#0 FiberWire®, blue, 97 cm, with diamond point needle, 22.2 mm, 1/2 circle	AR-7251

FiberWire® Sutures and SutureTape

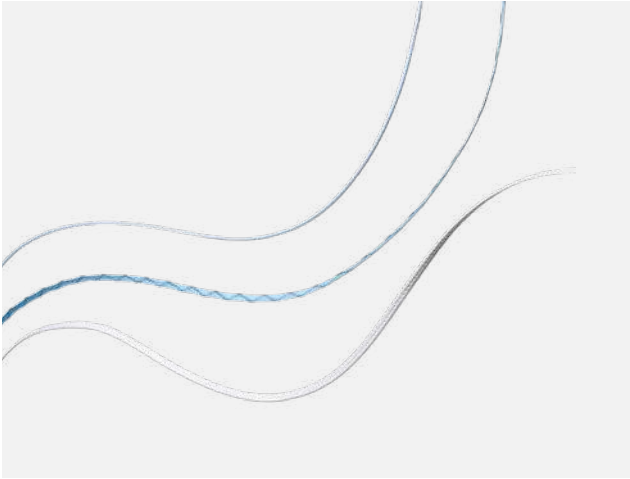

FiberWire suture is the polyester suture with an ultra-high-molecular-weight-polyethylene (UHMWPE) core. FiberWire has greater strength than polyester suture of the same size, with superior feel, smooth tying characteristics, and a lower knot profile. FiberWire is the ideal suture for most orthopedic soft tissue repairs,

virtually eliminating suture breakage during knot tying. FiberWire mini SutureTape is just 0.9 mm wide, compared to the 1.3 mm width of regular SutureTape. It comes with rounded ends to link to 1/2 circle needles. The mini SutureTape allows for tying smaller knot stacks, and the flat tape distributes the forces evenly.

Product Description	Item Number
#0 FiberWire®, white, 97 cm	AR-7255
#1 FiberWire®, blue, 97 cm	AR-7216
#2 FiberWire®, blue, 97 cm	AR-7233
#5 FiberWire®, blue, 97 cm	AR-7210
Mini SutureTape, white / blue, 0.9 mm wide, qty. 12	AR-7521
Free eye needles	3180

FiberLink™ and TigerLink™



FiberLink and TigerLink SutureTape includes a 3.8 cm closed loop with a 61 cm tail of #2-0 FiberWire suture (0.9 mm). FiberLink SutureTape is solid blue and TigerLink SutureTape is white with black stripes to aid with suture management. Optionally a #0 FiberLink and TigerLink version is available. Each product is packaged in a box of 12.

Product Description	Item Number
FiberLink™, SutureTape, white / blue, 0.9 mm, with closed loop	AR-7559
TigerLink™, SutureTape, white / black, 0.9 mm, with closed loop	AR-7559T
#0 FiberLink™ suture, FiberWire® suture, blue, with 3.8 cm closed loop at 1 end	AR-7258
#0 TigerLink™ suture, TigerWire® suture, white / black, with 3.8 cm closed loop at 1 end	AR-7258T

FiberStick™ and TigerStick®

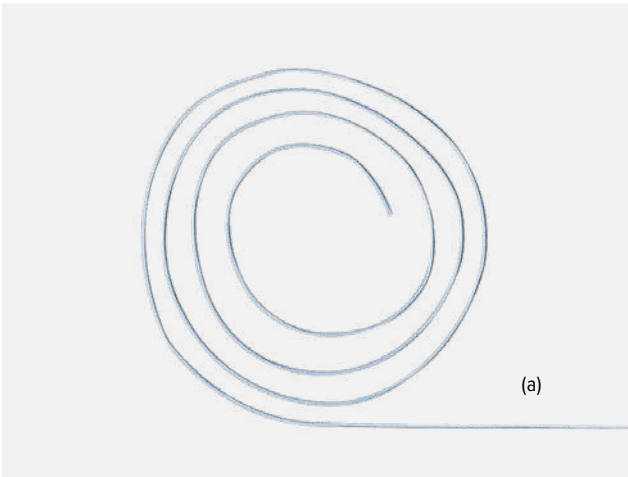

FiberStick, available in #2 or #2-0 sizes, is FiberWire with a 30 cm stiffened end. Used in conjunction with small-diameter cannulated suture-passing instruments, it makes suture passing easy. FiberSticks are sterile and come packaged with the stiff end in a plastic tube. TigerStick is a white #2 FiberStick with black stripes and a stiffened 30 cm end.

Product Description	Item Number
FiberStick™, #2 FiberWire®, blue, 127 cm, 1 end stiffened, 30 cm (a)	AR-7209
#2 TigerStick®, #2 TigerWire®, white / black, 127 cm, 1 end stiffened, 30 cm	AR-7209T
#2-0 FiberStick™, #2-0 FiberWire®, blue, 127 cm, 1 end stiffened, 30 cm	AR-7222

FiberSnare® Suture

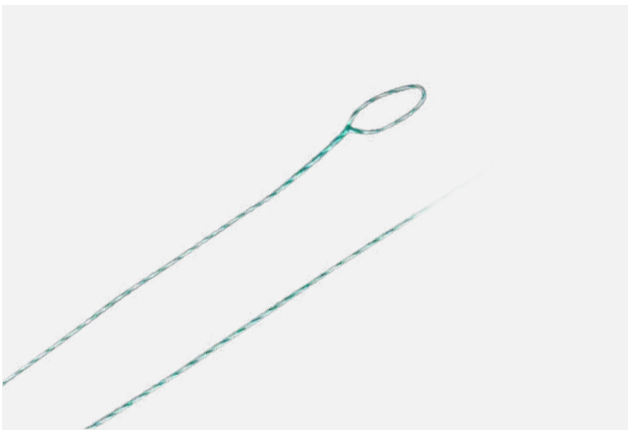

The FiberSnare suture with closed loop provides an easy, 1-step approach to creating a FiberWire loop on the tip of the Bio-Tenodesis driver. Instead of using a nitinol wire, insert the stiff nonlooped end retrograde through the tip of the Bio-Tenodesis driver. The FiberSnare suture can also be used as a suture shuttle to pass traction sutures through bone tunnels.

Product Description	Item Number
#2 FiberSnare® suture, #2 FiberWire® suture, 66 cm, 1 strand (green) stiffened, with closed loop, 30 cm	AR-7209SN

FiberTape®

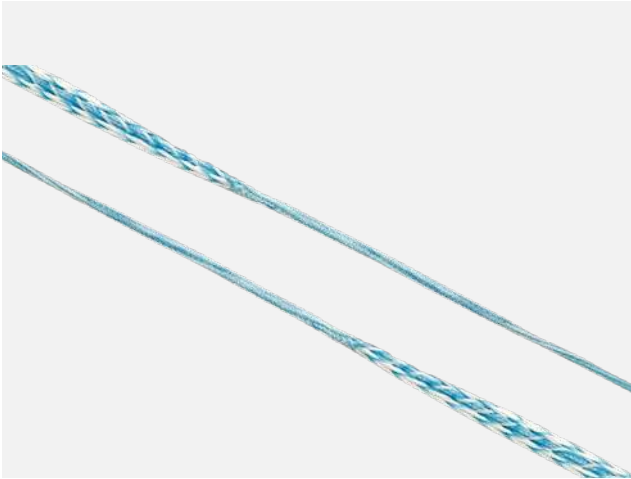

FiberTape is an ultra-high-strength, 2 mm wide tape using the same long-chain polyethylene structure as the FiberWire suture. The broad base of the FiberTape is suitable for repairs in degenerative tissue where tissue pull-through may be a concern.

Product Description	Item Number
FiberTape®, blue, 2 mm wide, 97 cm long, each end tapered to #2 FiberWire®, 20 cm, total length 137 cm	AR-7237

Suture Tensioner With Tensiometer

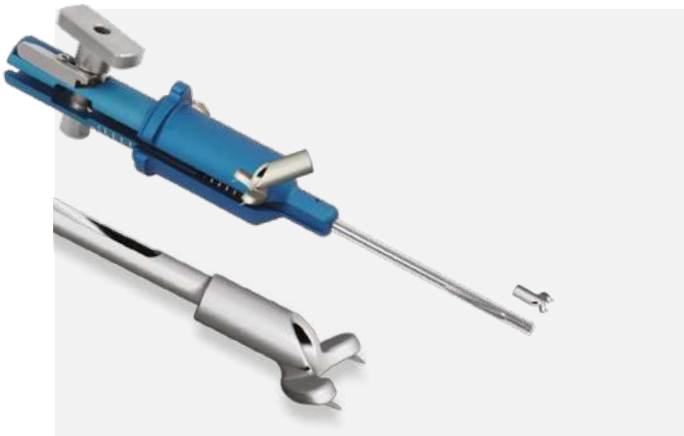

The suture tensioner with tensiometer enables a defined tensioning of the ACL graft over a button. It also makes it possible to knot a backup suture.

Product Description	Item Number
Suture tensioner, with tensiometer	AR-1529
Tensiometer foot	AR-1530

Graft Prep, Sizing, and Pretensioning

GraftPro® Graft Preparation Set.....	40
Graft Compression Tubes	41

GraftPro® Graft Preparation Set

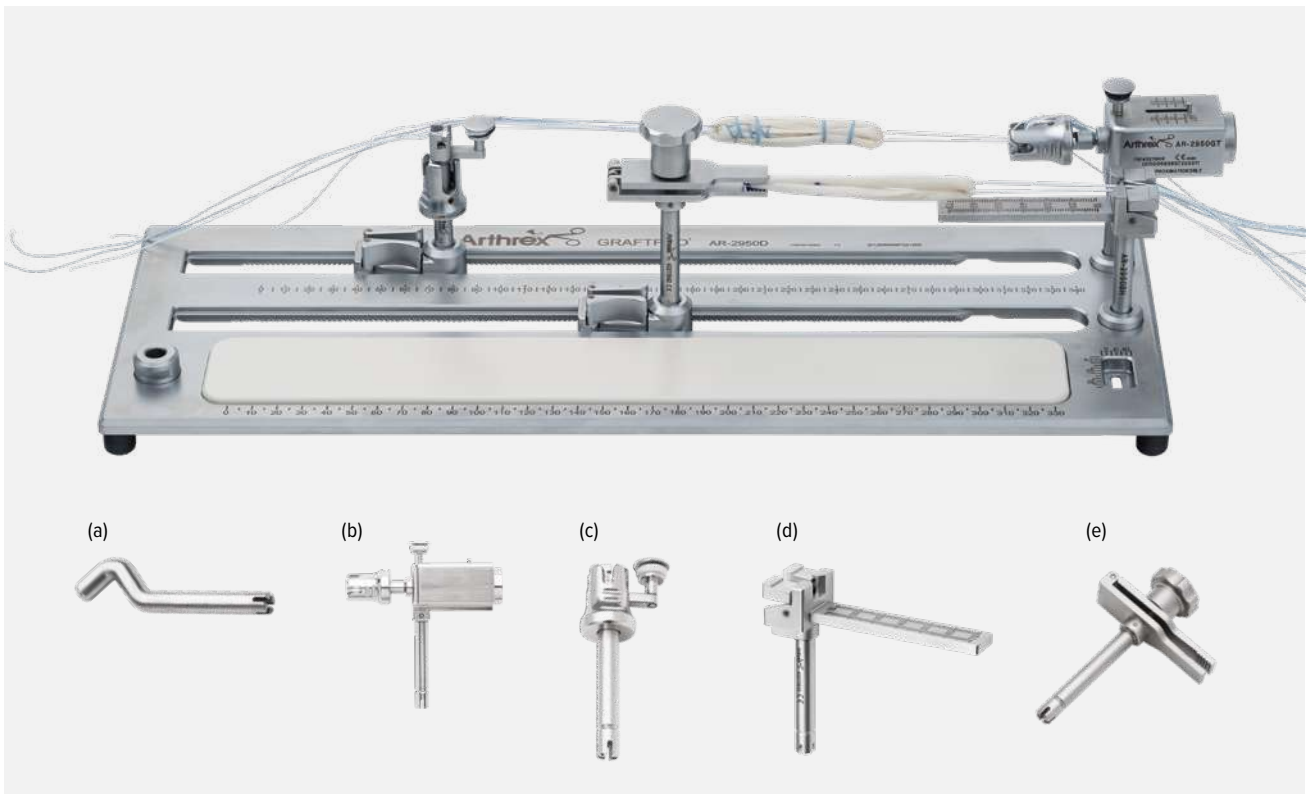

The new GraftPro system brings graft preparation and tensioning to a new level of simplicity and convenience. The unique ratcheting adjustment track system allows 1-handed movement of attachments along the length of the board and locks them into place automatically. All attachments are interchangeable, from the adjustable tracks to the fixed positions. Two parallel rails allow simultaneous preparation and tensioning of 2 grafts at a time, or when performing a single double-bundle graft. The BTB well facilitates stable cutting of patella tendon bone blocks to size and drilling of suture holes through the board. Enhanced attachments hold a variety of implants and grafts in place firmly and atraumatically.

GraftPro® Graft Preparation System (AR-2950DS)

Product Description	Item Number
GraftPro® case	AR-2950DC
GraftPro® board	AR-2950D
GraftPro® posts (a)	AR-2950AP
GraftPro® GraftLink® tensioner (b)	AR-2950GT
GraftPro® GraftLink® holder (c)	AR-2950GH
GraftPro® button holder (d)	AR-2950BH
GraftPro® soft-tissue clamp (e)	AR-2950SC
Graft sizing block	AR-1886
Optional	
Cutting board clamp	AR-2950CBC

GraftPrep Workstation First Generation

Product Description	Item Number
Workstation holding pins, for hamstring grafts, fixed, qty. 2	AR-1951
Workstation holding pins, for hamstring grafts, adjustable	AR-1953
Workstation holding pins, for patellar tendon grafts, qty. 2	AR-1959
Soft-tissue clamp, adjustable	AR-1967A
Soft-tissue clamp, fixed	AR-1967F
Graft prep station base, large	AR-2950
Workstation GraftLink® holder, adjustable	AR-2951-1
Workstation GraftLink® holder, with tensiometer, adjustable	AR-2951-2
Replacement adjusting screw, for graft prep station, short	AR-2951-3
O-Ring, for GraftLink® prep-posts	AR-2951R
Replacement adjusting screw, for graft prep station, long	AR-1588GPH

Graft Compression Tubes



GraftLink compression tubes are full-circumference, full-length, autoclavable, clear tubes that facilitate graft compression, sizing, and preparation. The unique transparent tubes with an etched ruler allow visualization of the graft during diameter and length sizing. The funneled entrance and attachable handle facilitate the entry of grafts into the sizer, allowing compression of up to 2 mm. The tapered tip allows delivery of the graft directly into the tibial tunnel or medial portal.

GraftLink® Graft Tube Set (AR-1886-S)

Product Description	Item Number
GraftLink® graft tubes, 5 - 13 mm (0.5 mm increments)	AR-1886-050 to -130
GraftLink® graft tube flange	AR-1886-001
GraftLink® graft tube instrument case	AR-1886C-01

Graft Fixation

ACL TightRope® II Implant System	44
ACL TightRope® II RT With and Without <i>InternalBrace</i> ™	44
BTB TightRope® II Implants	45
TightRope® II ABS Implant	45
FiberTag® TightRope® Implant.....	46
ACL TightRope® Implants.....	46
TightRope® Button Extender.....	47
TransFix® Implant.....	47
FastThread™ BioComposite Interference Screw	48
FastThread™ PEEK Interference Screw.....	49
GraftBolt® Implant.....	50
Titanium Inteference Screws.....	51
ACL Backup Fixation.....	52
Suture Buttons.....	53
RetroButton® XL Implant	53
RetroButton® Implant.....	53
ACL / PCL Cortical Fixation Set	54
Bio-Tenodesis™ Screw System.....	55

ACL TightRope® II Implant System



The ACL TightRope fixation system offers adjustable cortical fixation for cruciate ligament reconstruction. ACL TightRope eliminates the need for different implant sizes. It also facilitates complete graft passing in the short femoral tunnels that are common with anatomic ACL drilling. The ACL TightRope II implant is the first SutureTape braided adjustable loop system on the market.

Flat SutureTape offers better handling characteristics and is more resistant to graft abrasion or pull-through than traditional round sutures. An improved, proprietary 5-point locking design resists cyclic displacement and makes tying a knot unnecessary. It enables precise tensioning and the ability to incrementally re-tension the construct. The TightRope II product line is available in multiple configurations to accommodate various graft types and techniques. RT and BTB implants are available double-loaded or with *Internal/Brace*. ABS available as standard or open.

Accessories for All TightRopes® Except ABS

Product Description	Item Number
ACL TightRope® guide pin, open eyelet, 4 mm	AR-1595T
ACL TightRope® guide pin, closed eyelet, 4 mm	AR-1595TC
ACL TightRope® suture tensioner	AR-1588H
TightRope® button extender	AR-1589RT

ACL TightRope® II RT With and Without *Internal/Brace*™

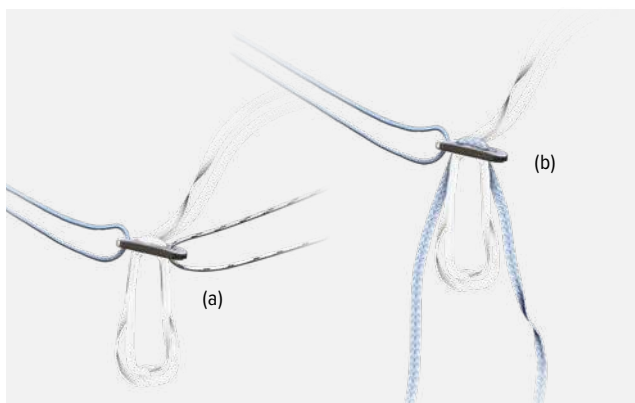

ACL TightRope II RT comes with double-loaded passing sutures which allows safe suture passage and controlled cortical button placement. The TightRope II RT with *Internal/Brace* ligament augmentation implant is loaded with an additional FiberTape suture in order to reinforce the tendon graft by allowing individual tensioning of the graft and the IB construct. On the tibial side, the *Internal/Brace* can be fixed with SwiveLock anchors, using the ACL backup fixation kit, or by knotting it on top of the TightRope ABS button.

Product Description	Item Number
TightRope II RT (a)	AR-1588RT-2J
TightRope II RT-IB (b)	AR-1588RT-IB
ACL SwiveLock® Backup Fixation Kit (AR-1593)	
BioComposite SwiveLock® anchor, with closed eyelet, 4.75 mm × 19.1 mm	AR-2324BCC
Drill, spade tip	AR-1927D
Punch / tap, for 4.75 mm SwiveLock®	AR-2324PTB

BTB TightRope® II Implants

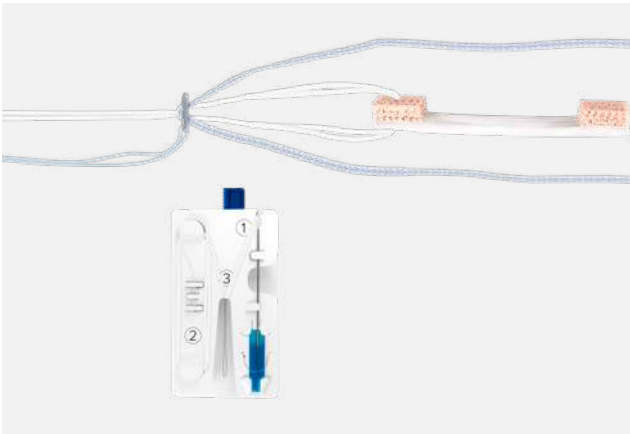

The simplicity and strength of ACL TightRope II can also be used with bone-tendon ACL grafts. The BTB TightRope II offers the same adjustable, 5-point locking system as the ACL TightRope II RT, but allows placement through a small drill hole in the cortical bone block. The BTB TightRope II comes with double-loaded

passing sutures, which allow safe suture passage and controlled cortical button placement. The BTB TightRope II, *Internal/Brace* is pre-loaded with an additional FiberTape suture in order to reinforce the BTB graft by allowing individual tensioning of the graft and the IB construct. On the tibial side, the *Internal/Brace* can be fixed with SwiveLock anchors, using the ACL backup fixation kit, or by knotting it on top of the TightRope ABS Button.

Product Description	Item Number
TightRope II BTB-2J	AR-1588BTB-2J
TightRope II BTB-IB	AR-1588BTB-IB
ACL SwiveLock® Backup Fixation Kit (AR-1593)	
BioComposite SwiveLock® anchor, with closed eyelet, 4.75 mm × 19.1 mm	AR-2324BCC
Drill, spade tip	AR-1927D
Punch / tap, for 4.75 mm SwiveLock®	AR-2324PTB

TightRope® II ABS Implant

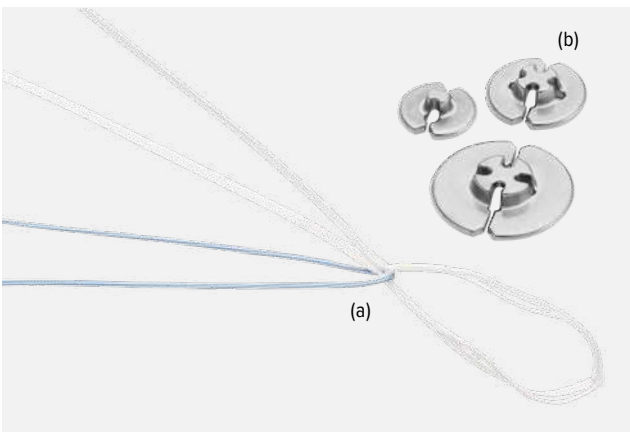

The unique TightRope No-Button system allows the ACL TightRope implant to be passed through the bone tunnel without a button. After passage through the bone tunnel, an individually selectable ABS button for

cortical fixation is threaded in and tightened. Can be used for both all-inside and cortical standard fixation with completely drilled tibial tunnels.

Product Description	Item Number
TightRope® II ABS implant (a)	AR-1588TN-20
TightRope® II ABS implant ,open	AR-1588TN-21
Button Options	
TightRope® ABS button, round, 14 mm	AR-1588TB-1
TightRope® ABS button, oval, 3.4 mm × 13 mm	AR-1588TB-2
ABS button, round, concave, Ø 11 mm	AR-1588TB-3
ABS button, round, concave, Ø 14 mm (b)	AR-1588TB-4
ABS button, round, concave, Ø 20 mm	AR-1588TB-5

FiberTag® TightRope® Implant

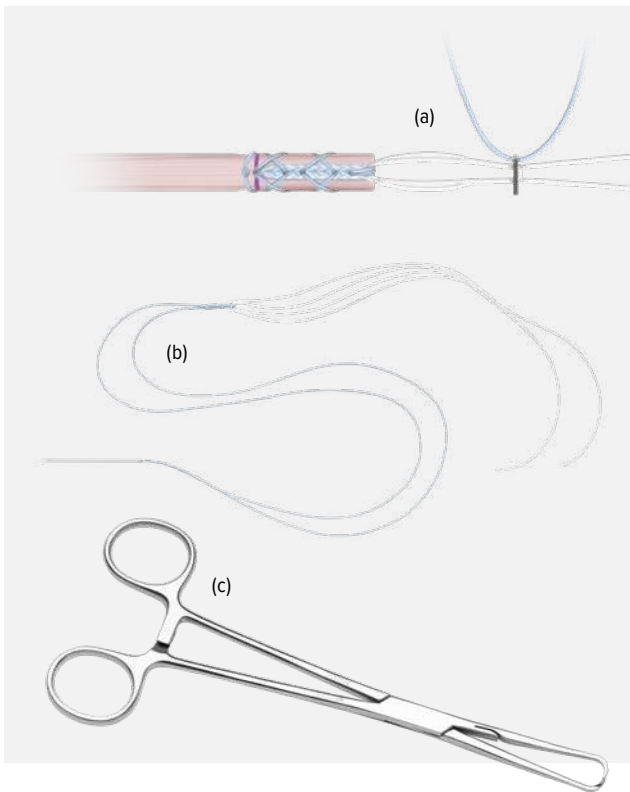

The ACL TightRope with FiberTag implant facilitates attachment of ACL TightRope RT and ABS implants to single-ended grafts, such as quadriceps tendon grafts. The simplified suturing technique, along with innovative packaging and new GraftClamp graft preparation instrument, makes preparing quad tendon grafts faster and more reproducible than ever.

Product Description	Item Number
FiberTag® TightRope® implant (a)	AR-1588RTT
FiberTag® TightRope® ABS implant (b)	AR-1588TNT
GraftClamp graft prep instrument (c)	AR-2386T
FiberTag® Implants From First Generation	
FiberLoop®, with FiberTag®	AR-7264
FiberLoop®, with FiberTag®, suture loop, blue, with 5 cm FiberTape®, with reinforced needle	AR-7266

ACL TightRope® Implants

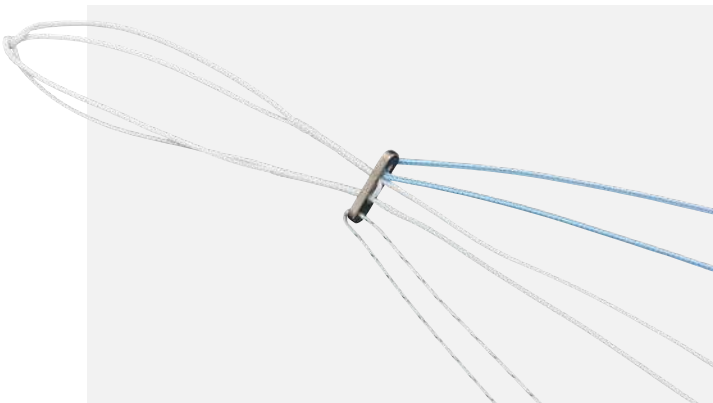

ACL TightRope RT allows surgeons to advance the graft by pulling the tensioning strands in the same direction of graft advancement. This innovation eliminates the need to retrieve tensioning strands from the joint and allows the surgeon to pull in line with graft advancement. The TightRope RT also facilitates tibial fixation with GraftLink.

Product Description	Item Number
ACL TightRope® RT	AR-1588RT
ACL TightRope® RT, double-loaded passing sutures	AR-1588RT-J
ACL TightRope® RT implant system, with ACL TightRope® guide pin	AR-1588RTS
ACL TightRope implant	AR-1588T
BTB TightRope®	AR-1588BTB
ACL BTB TightRope®, with flip suture	AR-1588BTB-J
ACL TightRope® No Button	AR-1588TN
Open TightRope® ABS	AR-1588TN-1
TightRope® ABS, with ABS button, Ø 11 mm	AR-1588TN-2
TightRope® ABS, with ABS button, Ø 14 mm	AR-1588TN-3
TightRope® ABS, with ABS button, Ø 20 mm	AR-1588TN-4
TightRope® ABS button, 8 mm × 12 mm	AR-1588TB

TightRope® Button Extender

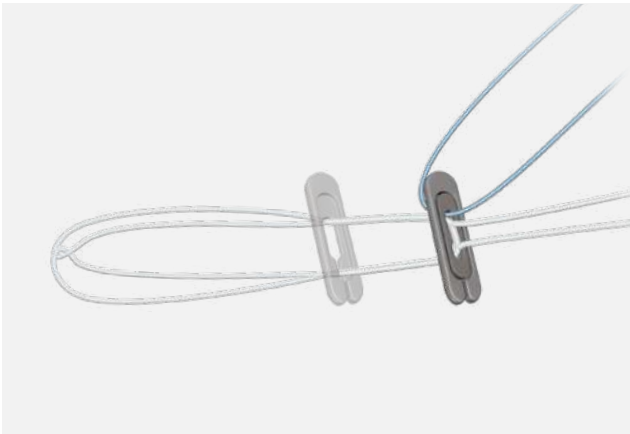

The TightRope button extender is ideal for cortical blow-outs, revisions, and the use of continuous bone tunnels. Loading onto a TightRope button is easy without having to remove the graft. A large 20 mm × 5 mm footprint maximizes button-to-bone contact against the cortex.

Product Description	Item Number
TightRope® button extender	AR-1589RT

TransFix® Implant

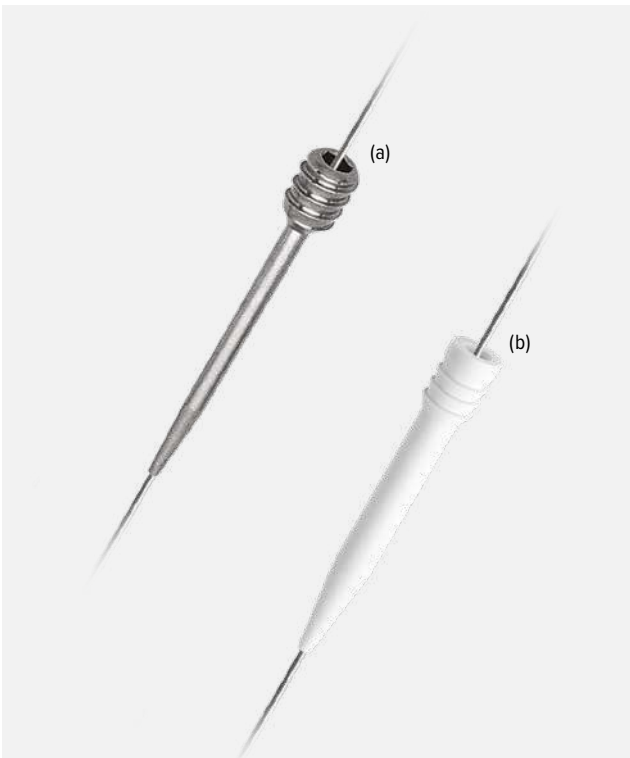

TransFix cross-pin fixation provides one of the strongest femoral fixation techniques for tendons or bone-tendon grafts available. TransFix implants are available in titanium and BioComposite (PLDLA and β-TCP).

Product Description	Item Number
TransFix® implant, titanium, 3 mm × 40 mm (a)	AR-1351
TransFix® implant, titanium, 3 mm × 50 mm	AR-1351L
BioComposite TransFix®, 5 mm × 40 mm	AR-1351C-01
BioComposite TransFix®, 5 mm × 50 mm (b)	AR-1351C-02
BioComposite TransFix® driver	AR-1973CD
TransFix® II drill set	AR-1978S

FastThread™ BioComposite Interference Screw

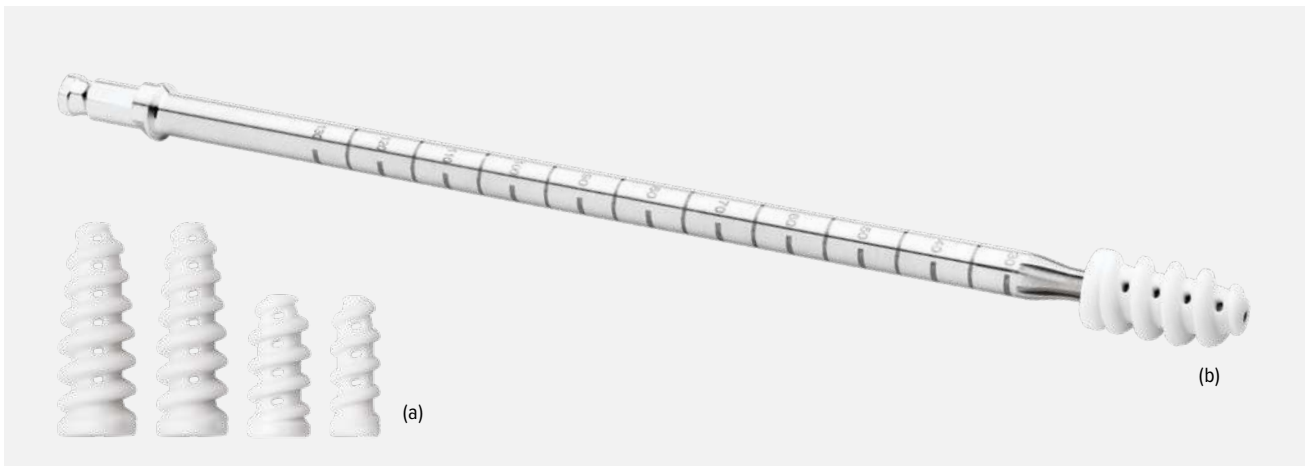

FastThread BioComposite interference screws are a completely new design with a prominent leading and large thread pitch to facilitate screw engagement and advancement. Vented sidewalls and screw geometry decrease material by 22 % without losing insertion or fixation strength.¹ The cannulation and fenestrations in the screw design allow for bony ingrowth and channeling of biologic growth factors during healing.¹

The screws, which come in 20 and 30 mm lengths, offer excellent strength on insertion and have been biomechanically tested.²

FastThread™ BioComposite Interference Screws

Product Description	Item Number
6 mm × 20 mm (used with 6 mm driver)	AR-4020C-06
7 - 10 mm × 20 mm screws	AR-4020C-07 to -10
7 - 12 mm × 30 mm screws (a)	AR-4030C-07 to -12
SlapDrivers	
SlapDriver, quick connect, ratcheting handle	AR-1999SD
Drivers for 6 mm × 20 mm Screws	
Driver, fixed handle	AR-4019D
Driver shaft, quick connect	AR-4019D-1
Drivers for 7 - 12 mm Screws	
Driver, for 20 and 30 mm screws, fixed handle	AR-1996CD
Driver, for 20 and 30 mm screws, quick connect	AR-1996CD-1
Driver, for 20 mm screws only, fixed handle	AR-4020D
Driver, for 20 mm screws only, quick connect (b)	AR-4020D-1
Driver, for 20 mm screws only, flexible shaft, quick connect	AR-4020DF
Screwdriver handle, nonratcheting	AR-1999NR
Screwdriver handle, ratcheting	AR-1999
Taps	
Taps, fixed handle, 6 - 10 mm	AR-4020HT-06 to -10
Tap shafts, quick connect, 6 - 10 mm	AR-4020T-06 to -10
Tap shafts, quick connect, flexible, 6 - 10 mm	AR-4020TF-06 to -10

Previous Generation: Biocomposite Interference Screws

Product Description	Item Number
Screws, with protective sleeve, 6 - 10 mm × 23 mm	AR-1360C to -1400C
Screws, full thread, 7 - 12 mm × 28 mm	AR-1370TC to -1404TC
Delta screws, round head, 8 - 11 mm × 28 mm	AR-5028C-08 to -11
Delta screws, 9 - 12 mm × 35 mm	AR-5035TC-09 to -12
Interference screwdriver, quick connect, BioComposite, long	AR-1996CDL-1
Dilator, for BioComposite interference screw, 6 - 8 mm (1 mm increments)	AR-1377C-06 to -08

Reference

1. Arthrex, Inc. LA1-00096-EN. Naples, FL; 2018.
2. Arthrex, Inc. LA1-00097-EN. Naples, FL; 2018.



FastThread™ PEEK Interference Screw

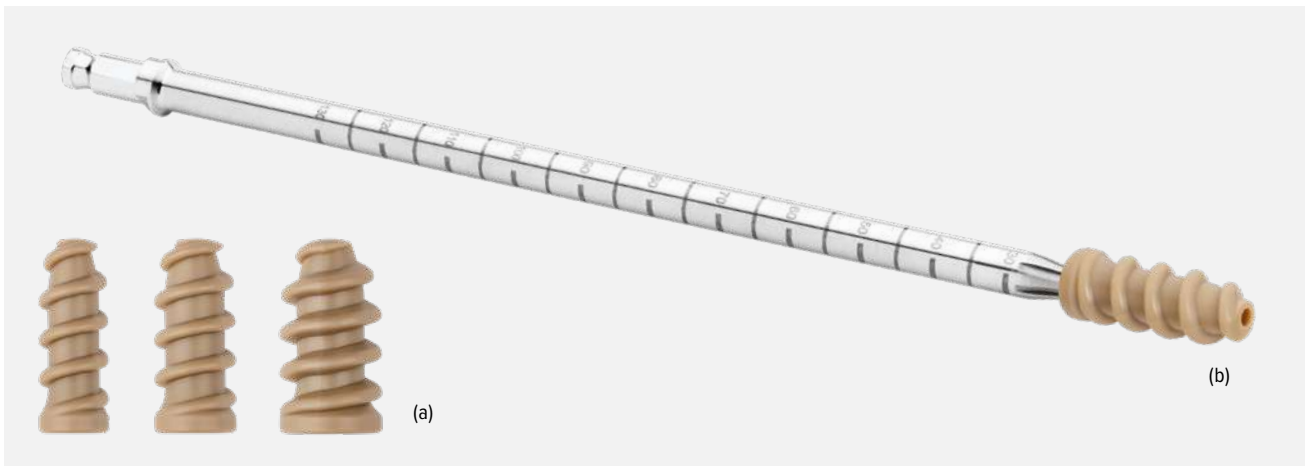

The PEEK family of FastThread interference screws offer similar advantages to the BioComposite FastThread screws, such as faster insertion, strength, and graft protection due to minimized friction against the graft. PEEK-OPTIMA material allows for insertion similar to metal screws by eliminating the need to tap.

FastThread™ PEEK Interference Screws

Product Description	Item Number
6 mm × 20 mm (used with 6 mm driver)	AR-4020P-06
7 - 10 mm × 20 mm screws (a)	AR-4020P-07 to -10
7 - 12 mm × 30 mm screws	AR-4030P-07 to -12
SlapDrivers	
SlapDriver, quick connect, ratcheting handle	AR-1999SD
Drivers for 6 mm × 20 mm Screws	
Driver, fixed handle	AR-4019D
Driver shaft, quick connect	AR-4019D-1
Drivers for 7 - 12 mm Screws	
Fixed Handle Driver for 20 mm and 30 mm Screws	AR-1996CD
Driver, for 20 and 30 mm screws, quick connect	AR-1996CD-1
Driver, for 20 mm screws only, fixed handle	AR-4020D
Driver, for 20 mm screws only, quick connect (b)	AR-4020D-1
Driver, for 20 mm screws only, flexible shaft, quick connect	AR-4020DF
Screwdriver handle, nonratcheting	AR-1999NR
Screwdriver handle, ratcheting	AR-1999
Taps	
Taps, fixed handle, 6 - 10 mm	AR-4020HT-06 to -10
Tap shafts, quick connect, 6 - 10 mm	AR-4020T-06 to -10
Tap shafts, quick connect, flexible, 6 - 10 mm	AR-4020TF-06 to -10

Previous Generation: PEEK Interference Screws

Product Description	Item Number
Interference screw, sheathed, PEEK, 6 - 10 mm × 23 mm	AR-1360P to -1400P
Delta screws, 7 - 12 mm × 28 mm	AR-5028P-07 to -12



GraftBolt® Implant



The GraftBolt is designed for tibial fixation of a soft tissue graft in cruciate ligament reconstruction procedures. The GraftBolt is available in PEEK and consists of a sheath and mating screw, which are packaged together. Both are fully cannulated. The GraftBolt instrument set includes dilators and sheath insertion and removal tools as well as the hexalobe driver for insertion of the screw.

Implants

Product Description	Item Number
GraftBolt®, with screw, 7 - 10 mm Diameter: 7, 8, 9, 10 mm	AR-5100-07 to -10

Transtibial Fixation Device Instrument Set (AR-5100S)

Product Description	Item Number
T-handle, quick connect GraftBolt® removal tool	AR-1416T AR-5102
GraftBolt® inserter, 7 mm	AR-5103
GraftBolt® inserter, 8 - 9 mm	AR-5104
GraftBolt® inserter, 10 mm	AR-5101
GraftBolt® dilator, 6 - 10 mm Diameter: 6, 7, 8, 9, 10 mm	AR-5106 to -5110
Graft spreader	AR-1842
Screwdriver handle, ratcheting	AR-1999
Driver, BioComposite interference screw, quick connect	AR-1996CD-1

Implants

GraftBolt®, with screw, 7 - 10 mm Diameter: 7, 8, 9, 10 mm	AR-5100-07 to -10
---	----------------------

Accessory Instruments

Suture tensioner, with tensiometer	AR-1529
Tensiometer foot	AR-1530
GraftBolt® instrument case	AR-5100C

Titanium Inteferece Screws



All screws are precision-manufactured from titanium alloy and are fully cannulated. They are supplied sterile and individually packed. All screws are used in conjunction with a 2 mm-diameter nitinol guide wire and can be inserted with a 3.5 mm, cannulated hex screwdriver. Soft screws come with a rounded head and provide femoral graft protection. Titanium Sheathed Interference Screws come with a disposable sheath to aid femoral insertion during transtibial ACL reconstruction. Full-thread titanium interference screws provide a secure bone block fixation. All screws can be inserted with a 3.5 mm, cannulated hex screwdriver.

Full-Thread Titanium Interference Screw (c)

Product Description	Item Number
Interference screw, full thread, cannulated, 7 mm × 20 mm	AR-1370T
Interference screw, full thread, cannulated, 7 mm × 25 mm	AR-1371T
Interference screw, full thread, cannulated, 7 mm × 30 mm	AR-1372T
Interference screw, full thread, cannulated, 8 mm × 20 mm	AR-1380T
Interference screw, full thread, cannulated, 8 mm × 25 mm	AR-1381T
Interference screw, full thread, cannulated, 8 mm × 30 mm	AR-1382T
Interference screw, full thread, cannulated, 9 mm × 20 mm	AR-1390T
Interference screw, full thread, cannulated, 9 mm × 25 mm	AR-1391T
Interference screw, full thread, cannulated, 9 mm × 30 mm	AR-1392T
Interference screw, full thread, cannulated, 10 mm × 20 mm	AR-1400T
Interference screw, full thread, cannulated, 10 mm × 25 mm	AR-1401T
Interference screw, full thread, cannulated, 10 mm × 30 mm	AR-1402T

Soft Screw (a)

Product Description	Item Number
Soft screw, cannulated, 7 mm × 25 to 35 mm (in 5 mm increments)	AR-1370H-25 to -35
Soft screw, cannulated, 8 mm × 25 to 35 mm (in 5 mm increments)	AR-1380H-25 to -35
Soft screw, cannulated, 9 mm × 25 to 35 mm (in 5 mm increments)	AR-1390H-25 to -35
Soft screw, cannulated, 10 mm × 25 to 35 mm (in 5 mm increments)	AR-1400H-25 to -35

Accessories

Product Description	Item Number
Guide pin, nitinol, 2 mm, with 25 and 30 mm depth markings	AR-1254
Guide pin, nitinol, 2 mm, with 25 and 30 mm depth markings, sterile	AR-1254-1S
PinLock II screwdriver, cannulated, 3.5 mm hex driver, Ø 5.5 mm × 14 cm, long	AR-1896
Screwdriver handle, nonratcheting	AR-1999NR
Transtibial screwdriver shaft, cannulated, 3.5 mm hex, Ø 4 mm × 19.6 cm	AR-1998T

Sheathed Interference Screw™ (b)

Product Description	Item Number
Sheathed Interference Screw™, cannulated, 6 mm × 20 mm	AR-1360E
Sheathed Interference Screw™, cannulated, 7 mm × 15 to 30 mm (in 5 mm increments)	AR-1370E to 75E
Sheathed Interference Screw™, cannulated, 8 mm × 20 to 30 mm (in 5 mm increments)	AR-1380E to 82E
Sheathed Interference Screw™, cannulated, 9 mm × 20 to 25 mm	AR-1390E to 91E

ACL Backup Fixation



Arthrex offers a wide range of soft tissue fixation devices for minimally invasive primary and backup fixation for knee ligament reconstruction and repair procedures.

Product Description	Item Number
ACL SwiveLock® PEEK fixation kit	AR-1593-P
SwiveLock® anchor, PEEK, 4.75 mm	AR-2324PSL
Drill, spade tip	AR-1927D
Tap, 4.75 mm	AR-2324PTB
Tap, for hard bone, 5.2 mm	AR-1593-5
SwiveLock® backup ACL fixation kit	AR-1593
SwiveLock® anchor, BioComposite, 4.75 mm	AR-2324BCC
Drill, spade tip	AR-1927D
Tap, 4.75 mm	AR-2324PTB
Tap, for hard bone, 5.2 mm	AR-1593-5
Suture Anchors	
BioComposite Corkscrew® FT, 4.5 mm × 14 mm, with two #2 FiberWire®	AR-1927BCF-45
BioComposite Corkscrew® FT, 5.5 mm × 14.7 mm, with two #2 FiberWire®	AR-1927BCF
BioComposite Corkscrew® FT, 5.5 mm × 14.7 mm, with two #2 TigerTail®	AR-1927BCFT
BioComposite Corkscrew® FT, with 4 needles, 5.5 mm × 14.7 mm, with two #2 FiberWire®	AR-1927BCNF
BioComposite Corkscrew® FT, 5.5 mm × 14.7 mm, with three #2 FiberWire®	AR-1927BCF-3
BioComposite Corkscrew® FT, 6.5 mm × 14.7 mm, with two #2 FiberWire®	AR-1927BCF-65

Suture Buttons



Titanium suture buttons with 2 or 4 holes are ideal for primary or backup FiberWire fixation of ACL / PCL grafts and augmenting bone bridges. Suture buttons come sterile and ready for use.

Product Description	Item Number
Suture Button, round, 3.5 and 12 mm	AR-8920 to AR-8922
Suture button inserter	AR-8923

RetroButton® XL Implant

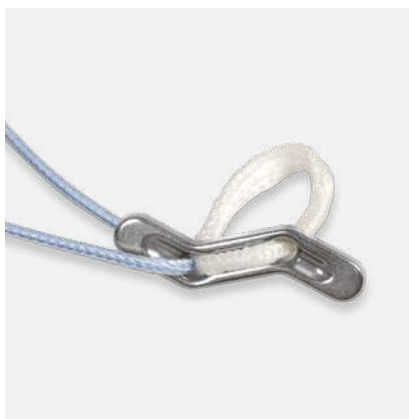

The RetroButton XL implant's unique button provides better coverage over cortical bone while minimizing the distance the button must travel past the cortex to flip. The "Z"-shaped button covers 20 mm of bone with only 18 mm of overall length. This facilitates flipping and decreases the chance of catching soft tissue under the button. The short 11 mm loop allows the graft to be positioned directly under the button, maximizing soft-tissue fill in short tunnels. Use the RetroButton XL implant when the femoral cortex is inadvertently damaged during drilling, for revision ACLR, or when the femoral condyle is too small for a socket.

Product Description	Item Number
RetroButton® XL implant, 20 mm long, 11 mm loop	AR-1592

RetroButton® Implant



The RetroButton implant is the fastest way to obtain strong suture-button fixation on cortical bone. The 12 mm and 15 mm long titanium buttons pass through a small cortical pinhole without overdrilling. The GraftPro button holder attachment allows graft tensioning with the RetroButton implant in place and confirms proper loop length.

Product Description	Item Number
RetroButton® implant, 12 mm, with 15 - 30 mm loop	AR-1588-15 to AR-1588-30
RetroButton drill pin II	AR-1595
RetroButton drill pin, 3 mm	AR-1590
RetroButton depth guide	AR-1270
GraftPro® button holder	AR-2950BH

ACL / PCL Cortical Fixation Set

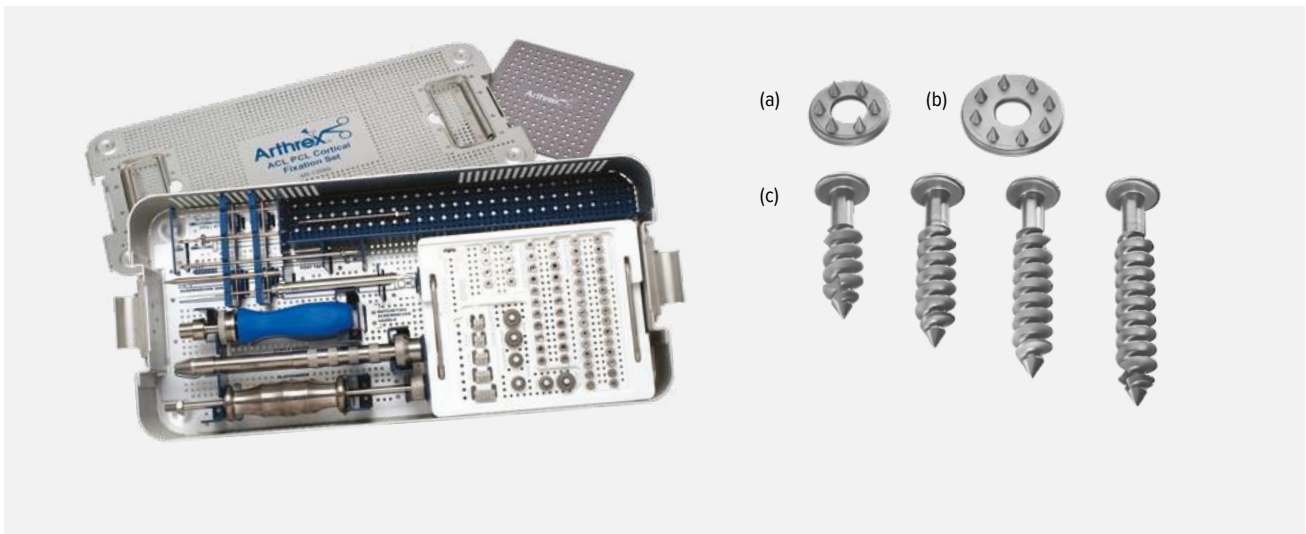

The ACL / PCL cortical fixation set combines the instruments of the bi-cortical low-profile post system (AR-1365S), the low-profile ligament staple driver set (AR-1005S), and the low-profile cancellous screw and washer instruments (AR-1359). The set also includes an implant caddy to hold the screws, washers, and staples (sold separately).

The system includes the 4.5 and 6.5 mm-diameter bi-cortical post and 6.5 mm cancellous screws. Low-profile spiked and unspiked washers, as well as ligament staples, are also included.

ACL / PCL Cortical Fixation Set (AR-1359S)

Product Description	Item Number
Instrumentation	
Staple impactor	AR-1005
Replacement jaw set, for staple driver	AR-1005-01
Slap hammer / extractor	AR-1005H
Depth gauge, large	AR-4167
Drill, for cancellous screw, 25 mm length	AR-1355D
Drill, for bi-cortical screw	AR-1365D
Bi-cortical Bio-Post® drill	AR-1367D
Screwdriver shaft, noncannulated, short, 2.5 mm hex	AR-1995SHN
Screwdriver shaft, cannulated, short, 3.5 mm hex	AR-1998SH
Screwdriver handle, ratcheting	AR-1999
Instrument case	AR-1359C

Product Description	Item Number
Implants	
Bi-cortical posts, 4.5 mm × 275 - 50 mm, sterile (2.5 mm increments)	AR-1365-275 to -50
Bi-cortical posts, 4.5 mm × 40 - 60 mm, nonsterile (2.5 mm increments)	AR-1365NS-40 to -575
Bi-cortical posts, 6.5 mm × 30 - 50 mm, nonsterile (2 mm increments)	AR-1366NS-30 to -50
Washers, for cancellous screws, spiked, 14 mm, sterile (a)	AR-1349
Washers, for cancellous screws, spiked, 18 mm, sterile (b)	AR-1349L
Screw, low profile, cancellous, 6.5 mm × 25 - 40 mm, sterile (5 mm increments) (c)	AR-1355 to -1358
Ligament staple, spiked, 6 mm width, sterile	AR-1006
Ligament staple, spiked, 8 - 16 mm width, sterile Width: 8, 11, 16 mm	AR-1008 to -1016
Ligament staple, spiked, 8 - 16 mm width, non-sterile Width: 8, 11, 16 mm	AR-1008NS to -1016NS

Bio-Tenodesis™ Screw System

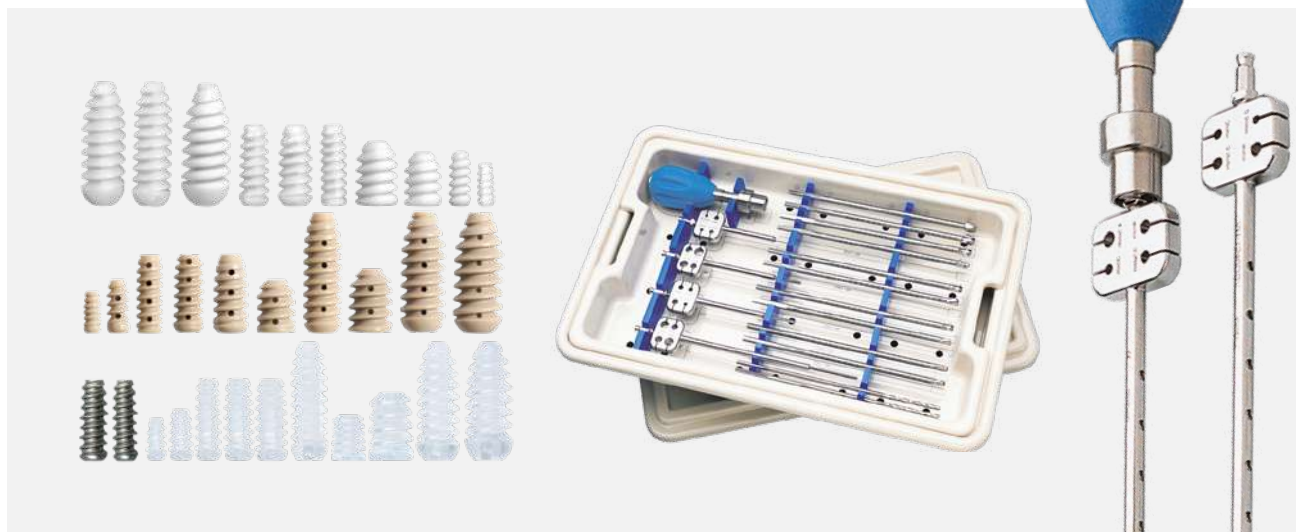

Backup fixation of ACL grafts using the Bio-Tenodesis screw system should be considered in situations of poor metaphyseal bone quality or when less than 1.7 Nm of insertion torque is quantified during delta screw insertion. The Bio-Tenodesis screw may be used to secure the graft end directly in a 1 cm distally drilled socket or with FiberWire alone as a screw / post substitute. The Bio-Tenodesis system is also ideal for collateral ligament, PCL, or ACL reconstruction.

Bio-Tenodesis™ Master Set (AR-1675S)

Product Description	Item Number
Handle, tear drop, with suture cleat	AR-2001BT
Headed reamers, cannulated, 5 - 10 mm Diameter: 5, 6, 7, 8, 9, 10 mm	AR-1405 to AR-1410
Drill bit, cannulated, 4 mm	AR-1204L
Drill bit, cannulated, 4.5 mm	AR-1204.5L
Driver, for 10 mm Bio-Tenodesis™ screw	AR-1540DB
Driver, for 12 mm Bio-Tenodesis™ screw	AR-1670DB
Driver, for 15 mm Bio-Tenodesis™ screw	AR-1350D
Driver, for 23 mm Bio-Tenodesis™ screw	AR-1570DB
Bio-Tenodesis™ screw instrumentation case	AR-1675C
Bio-Tenodesis™ screw and driver disposable pack, 5.5 mm × 15 mm	AR-1555DS
Disposables	
#2 FiberSnare®, #2 FiberWire®, green, 66 cm, stiffened end with closed loop, 30 cm	AR-7209SN
#2 FiberLoop®, with straight needle	AR-7234

Product Description	Item Number
BioComposite Tenodesis Screws	
Tenodesis screw, BioComposite, 4 mm × 10 mm	AR-1540BC
Tenodesis screw, BioComposite, 4.75 mm × 15 mm	AR-1547BC
Tenodesis screw, BioComposite, 5.5 mm × 15 mm	AR-1555BC
Tenodesis screw, BioComposite, 6.25 mm × 15 mm	AR-1562BC
Tenodesis screw, BioComposite, 7 mm × 23 mm	AR-1570BC
Tenodesis screw, BioComposite, 7 mm × 10 mm	AR-1670BC
Tenodesis screw, BioComposite, 8 mm × 12 mm	AR-1680BC
Tenodesis screw, BioComposite, 8 mm × 23 mm	AR-1580BC
Tenodesis screw, BioComposite, 9 mm × 23 mm	AR-1590BC
Tenodesis screw, PEEK, 4 mm × 10 mm	AR-1540PS
Tenodesis screw, PEEK, 4.75 mm × 15 mm	AR-1547PS
Tenodesis screw, PEEK, 5.5 mm × 8 mm	AR-1655PS
Tenodesis screw, PEEK, 5.5 mm × 10 mm	AR-1655PS-10
Tenodesis screw, PEEK, 5.5 mm × 12 mm	AR-1655PS-12
Tenodesis screw, PEEK, 5.5 mm × 15 mm	AR-1555PS
Tenodesis screw, PEEK, 6.25 mm × 15 mm	AR-1562PS
Tenodesis screw, PEEK, 7 mm × 10 mm	AR-1670PS
Tenodesis screw, PEEK, 7 mm × 23 mm	AR-1570PS
Tenodesis screw, PEEK, 8 mm × 12 mm	AR-1680PS
Tenodesis screw, PEEK, 8 mm × 23 mm	AR-1580PS
Tenodesis screw, PEEK, 9 mm × 23 mm	AR-1590PS
Tenodesis screw, titanium, 4.75 mm × 15 mm	AR-1350-475
Tenodesis screw, titanium, 5.5 mm × 15 mm	AR-1350-55

Screw Insertion and Removal

Tunnel Notchers.....	58
Interference Screw Insertion Kit.....	58
FastThread™ Interference Screw Instrumentation Set.....	59
ACL Revision Set.....	59

Tunnel Notchers

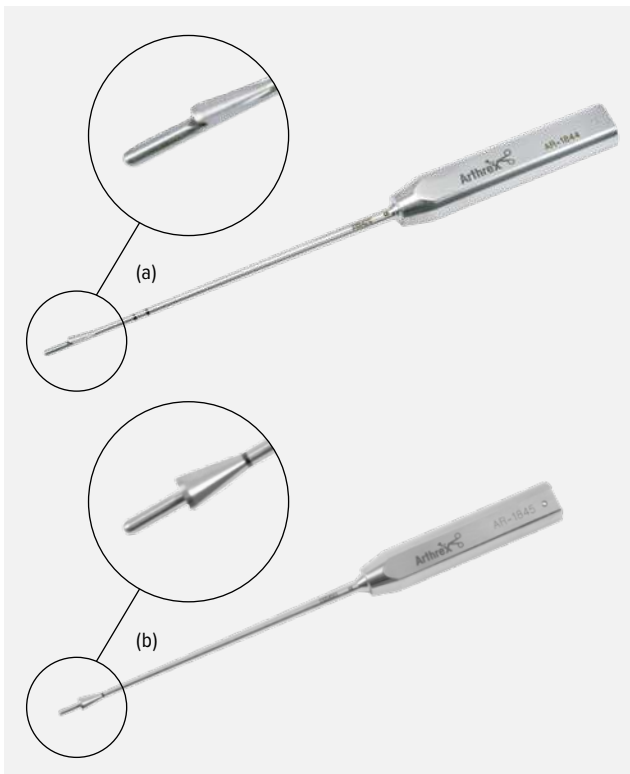

The tunnel notcher creates a perfectly sized “keyhole” in the anterior wall of the femoral tunnel to facilitate guide pin and interference screw insertion. The wider tunnel notcher for the bio-interference screw creates a broader “keyhole” in the anterior wall of the femoral tunnel to facilitate insertion of a bio-interference screw.

Product Description	Item Number
Tunnel notcher (a)	AR-1844
Tunnel notcher, for bio-interference screw (b)	AR-1845

Interference Screw Insertion Kit



The interference screw insertion kit was developed to improve screw trajectory and stability. This new tunnel notching system is offered as a disposables kit for convenience and reliability during anterior cruciate ligament (ACL) reconstruction.

Product Description	Item Number
Interference screw insertion kit, with dilator and 1.1 mm trocar-tip guide wire	AR-1249TK
Guide wire, trocar tip, 1.1 mm, qty. 5	AR-1249T
Guide wire, trocar tip, qty. 1	AR-1249T-1

FastThread™ Interference Screw Instrumentation Set



The torque measurement device, in conjunction with the ratcheting screwdriver handle, provides a quantifiable method of measuring insertion torque, which directly correlates to the pull-out strength of ACL / PCL reconstructions.

BioComposite Interference Screw Instrumentation Set (AR-1996S)

Product Description	Item Number
BioComposite interference screwdriver	AR-1996CD
BioComposite interference screwdriver, quick connect	AR-1996CD-1
Screwdriver handle, ratcheting	AR-1999
Driver Shaft, quick connect, 6 mm	AR-4019D-1
FastThread™ interference screw tap, 6 - 10 mm	AR-4020T-06 to -10
BioComposite interference screw instrumentation case	AR-1996C

ACL Revision Set



The ACL revision set conveniently combines all of the most commonly needed ACL implant removal instruments into 1 small case. AR-1998T can be used to remove interference screws from Arthrex.

ACL Revision Set (AR-1896RS)

Product Description	Item Number
Screwdriver handle, non-ratcheting	AR-1999NR
Transtibial screwdriver shaft, cannulated, 3.5 mm hex, Ø 4 mm × 19.6 cm	AR-1998T
Transtibial screwdriver shaft, 2.5 mm hex	AR-1998T-25
Transtibial screwdriver shaft, cannulated, 4 mm hex	AR-1998T-40
Screwdriver shaft, cannulated, for delta bio-interference screw	AR-1997D
Bio-TransFix extraction pin	AR-1973E
Easy-In	AR-1993
Easy-Out	AR-1994
ACL revision set instrumentation case	AR-1896RC

PCL Reconstruction

PCL ToolBox Instrumentation Set.....	62
PCL Suture Passing.....	63

PCL ToolBox Instrumentation Set

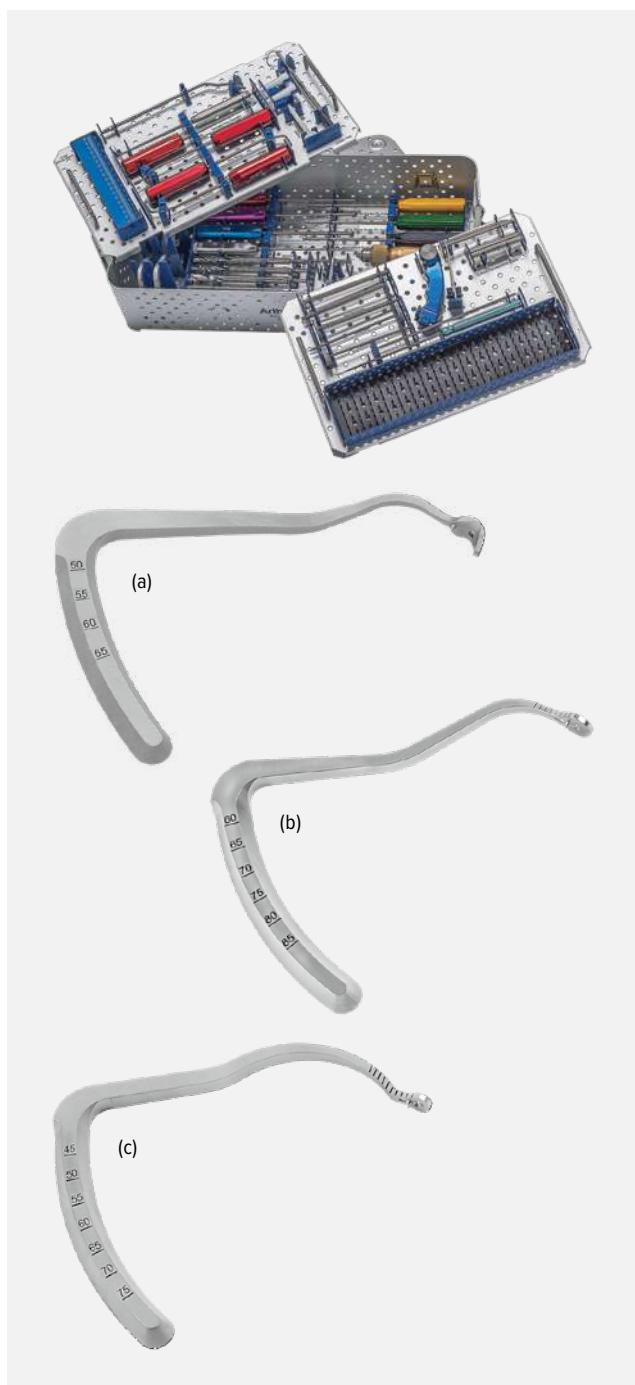

The PCL ToolBox addresses most modern PCL reconstruction techniques. The streamlined case includes the RetroConstruction guide handle, marking hooks and drill sleeves for FlipCutter, RetroDrill, and standard 2.4 mm guide pins. The set also includes all additional instruments needed for the procedure.

PCL Cruciate ToolBox Instrumentation Set (AR-1269S)

Product Description	Item Number
Probe, 3.4 mm tip with 5 mm markings	AR-10010
Drill sleeve, for RetroConstruction™ drill guide, stepped, 7 mm long tip	AR-1204FDS
Obturator, 3.5 mm	AR-1204F-OB
Insert for stepped drill sleeve, 2.4 mm	AR-1204F-24I
Drill, cannulated, 9 mm	AR-1209L
Drill, cannulated, 10 mm	AR-1214L
Drill, cannulated, 11 mm	AR-1217L
Parallel guide sleeve, 2.4 mm pins	AR-1245L
Offset drill guide, 3.5 mm	AR-1246-1
Offset drill guide pin, 3.5 mm	AR-1246-3
Tunnel plug for 8, 9, 10, 11, and 12 mm drill holes	AR-1258
PCL suture pusher	AR-1263
PCL rasp	AR-1264
PCL popliteal protector cap	AR-1267
Worm curving suture passer	AR-1268D
Jacobs chuck handle	AR-1415
Cannulated headed reamers, 8 - 11 mm Diameter: 8, 9, 10, 11 mm	AR-1408 to -1411
Cannulated headed reamers, 8.5 - 10.5 mm Diameter: 8.5, 9.5, 10.5 mm	AR-1408.5 to -1410.5
RetroConstruction™ drill guide handle	AR-1510H
PCL tibial marking hook, for RetroConstruction™ drill guide (b)	AR-1510PT
Femoral PCL marking hook, for RetroConstruction™ drill guide (c)	AR-1510PF
Anatomic contour PCL guide, left (a)	AR-1510PTL
Anatomic contour PCL guide, right	AR-1510PTR
Drill sleeve, for RetroConstruction™ drill guide, 2.4 mm	AR-1778R-24
Drill sleeve, for RetroConstruction™ drill guide, 3 mm	AR-1778R-30
Tunnel notcher, for bio-interference screw	AR-1845
Graft sizing blocks, 4.5 - 12 mm (in 0.5 mm increments)	AR-1886
Driver, BioComposite interference screw, quick connect	AR-1996CD-1
Screwdriver shaft, cannulated, for delta bio-interference screw	AR-1997D
Screwdriver shaft, cannulated, 3.5 mm hex, Ø 5.5 mm × 17 cm	AR-1998
Screwdriver handle, ratcheting	AR-1999
PCL curved curette, closed end	AR-5013
PCL straight curette, closed end	AR-5014
Chuck key	AR-8241
Instrument case for PCL reconstruction system	AR-1269C

PCL Suture Passing



The PCL curving suture passer is designed to carry graft-passing sutures through the tibial tunnel into the intercondylar notch. As the wire loop and suture exit the tube, the wire curves into the notch for easy viewing and suture retrieval through the femoral tunnel. The diameter allows the curving suture passer to be pushed through a 3.5 mm hole created by the FlipCutter.

Product Description	Item Number
Curving suture passer, disposable	AR-1268D

Collateral Ligament Reconstruction and Repair

Collateral Ligament Reconstruction Set.....	66
Medial Collateral Ligament (MCL) Augmentation	67
Anterolateral Ligament Reconstruction Set.....	67

Collateral Ligament Reconstruction Set



The collateral ligament reconstruction set allows for precision-based, biomechanically validated anatomic reconstructions of individual components and main structures of the posterolateral and medial knee. For minimally invasive and open techniques performed during fibular-based reconstructions, use the unique fibular marking hook, which tightly contours the fibular head and enables surgeons to get around anatomic structures while placing the 8 mm-diameter paddle. This marking hook was designed specifically to fit onto the fibular attachment of the popliteofibular ligament (PFL). The tibial marking hook was designed for posterolateral and medial / posteromedial tibia-based reconstructions. The ergonomic, 8 mm-diameter paddle provides tactile feedback upon entry into the posterior popliteal sulcus and confirms the zebra guide pin's exit point during posterolateral corner reconstructions. Increase the efficiency of anatomic tunnel drilling using the parallel drill guide, which reduces divergent tunnels and allows precision placement at multiple incremental distances for medial and lateral femoral-based reconstructions.

Collateral Ligament Reconstruction Set (AR-5500S)

Product Description	Item Number
Fibular marking hooks	AR-5500
Tibial marking hook, for the posterolateral corner	AR-5501
Femoral collateral marking hook	AR-5502
Parallel drill guide	AR-5503
Collateral ligament retractor	AR-5504
Collateral ligament rasp	AR-5506
RetroConstruction™ drill guide handle	AR-1510H
Graft sizing blocks, 4.5 - 12 mm (in 0.5 mm increments)	AR-1886
Drill, cannulated, 6 mm	AR-1206L
Drill, cannulated, 7 mm	AR-1207L
Drill, cannulated, 8 mm	AR-1208L
Drill, cannulated, 9 mm	AR-1209L
Drill, cannulated, 10 mm	AR-1214L
Drill, cannulated, 11 mm	AR-1217L
Drill, cannulated, 15 mm	AR-1215L
Accessories	
Zebra guide pin, open eyelet, 2.4 mm	AR-1250Z
ACL TightRope® drill pin, open eyelet, 4 mm	AR-1595T
Tunnel notcher, for bio-interference screw	AR-1845
#2 FiberLoop®, with straight needle	AR-7234
FiberStick™, #2 FiberWire®, blue, 127 cm, one end stiffened, 30 cm	AR-7209
Implants	
ACL TightRope®	R-1588RT-2J
ACL TightRope® RT	AR-1588TB-2
ACL TightRope® RT, with flip suture	AR-1588TN-20
BTB TightRope®, with flip suture	AR-1588TN-21
TightRope® ABS button, oval, 3.4 mm × 13 mm	AR-1588TB-2
ABS button, round, concave, Ø 11 mm	AR-1588TB-3
ABS button, round, concave, Ø 14 mm	AR-1588TB-4
FiberTag® TightRope® implant	AR-1588RTT
FiberTag® TightRope® ABS implant	AR-1588TNT
BioComposite Corkscrew® FT, with 4 needles, 5.5 mm × 14.7 mm, with two #2 FiberWire® sutures	AR-1927BCNF
FastThread™ BioComposite interference screws, 6 mm × 20 mm (used with 6 mm driver)	AR-4020C-06
FastThread™ BioComposite interference screws, 7 - 10 mm × 20 mm screws	AR-4020C-07 to -10
FastThread™ BioComposite interference screws, 7 - 12 mm × 30 mm screws	AR-4030C-07 to -12
Arthroscopic Reconstruction of the Popliteal Complex	
Tibial popliteal marking hook	AR-1510PT-1

Patellofemoral Procedures

Medial Patellofemoral Ligament (MPFL)	70
Deepening Trochleoplasty	71
Quadriceps Tendon PARS Technique	72

Medial Patellofemoral Ligament (MPFL)

The MPFL convenience pack was developed for reconstruction of the MPFL in cases of acute patellar dislocation or chronic patellofemoral instability. These convenience packs allow the MPFL reconstruction to be accomplished in an anatomic fashion, replicating the native MPFL in position and function. The MPFL convenience pack provides a complete solution for MPFL reconstruction procedures. Each kit provides a complete solution and includes implants, instruments, and an intraoperative radiographic template for identifying the femoral origin of the MPFL for to properly position the graft in the femur.

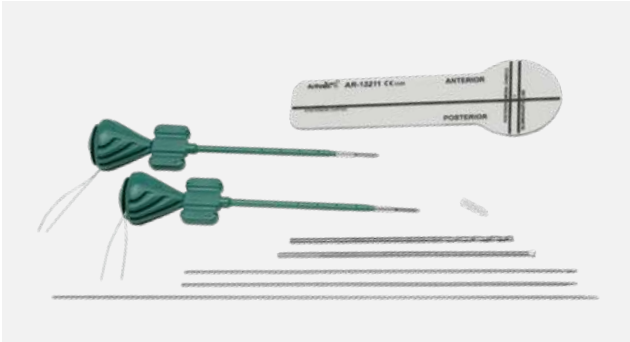

MPFL Implant System with Interference Screw (AR-1360C-CP)

Product Description	Item Number
MPFL Template	AR-13211
BioComposite SwiveLock®, 4.75 mm × 19.1 mm, qty. 2	AR-2324BCC
BioComposite interference screw, with disposable sheath, 6 mm × 23 mm	AR-1360C
Guide pin, with suture eyelet, 2.4 mm	AR-1297L
Drill tip guide pin, 2.4 mm, qty. 2	AR-1250L-1
Reamer, low profile, 7 mm	AR-1407LP
Drill, cannulated, 4.5 mm	AR-1204.5L

MPFL Implants-Only System with Interference Screw (AR-2324BCC-CP)

Product Description	Item Number
MPFL template (a)	AR-13211
BioComposite SwiveLock®, 4.75 mm × 19.1 mm, qty. 2	AR-2324BCC
BioComposite interference screw, with disposable sheath, 6 mm × 23 mm	AR-1360C



MPFL Implant System with TightRope® Implant (AR-1360CST-CP)

Product Description	Item Number
MPFL template	AR-13211
BioComposite SwiveLock®, 3.5 mm × 15.8 mm, qty. 2	AR-2325BCC
ACL TightRope® implant	AR-1588RT
ACL TightRope® drill pin, spade tip, closed eyelet, 4 mm	AR-1595TC
Drill tip guide pin, 1.1 mm, qty. 2	AR-8655K-11
Reamer, low profile, 6 mm	AR-1406LP
Drill, cannulated, 3.5 mm	AR-1531C-35

Deepening Trochleoplasty



One of the most frequent causes of patellofemoral dysfunction is habitual patella dislocation or subluxation. This system is designed to solve structural causes of patellar instability through a reproducible, deepening trochleoplasty. This instrumentation allows the cartilage layer to be released using a marking hook and burr, at which point the trochlea is deepened to a more natural groove. The cartilage is reattached using a PushLock suture anchor and resorbable sutures.

Deepening Trochleoplasty

Product Description	Item Number
Implants	
BioComposite PushLock® anchor, 3.5 mm × 19.5 mm	AR-1926BC
BioComposite PushLock® suture anchor, 3.5 mm × 19.5 mm	AR-1926BC-1
PushLock® suture anchor, 3.5 mm × 19.5 mm	AR-1926PS-1
Instrumentation	
RetroConstruction™ drill guide handle	AR-1510H
Marking hook, for trochleoplasty, 3 mm offset	AR-1510TP-03
Marking hook, for trochleoplasty, 5 mm offset (a)	AR-1510TP-05
Punch, for 3.5 mm PushLock® anchor	AR-1926P
Trochleoplasty tamp (b)	AR-1282-01

Disposable Kit (AR-300-B301S)

Product Description	Item Number
Drill sleeve, for trochleoplasty, inner Ø 4.5 mm	----
Burr, straight, 2.9 mm × 162 mm	----

Quadriceps Tendon PARS Technique

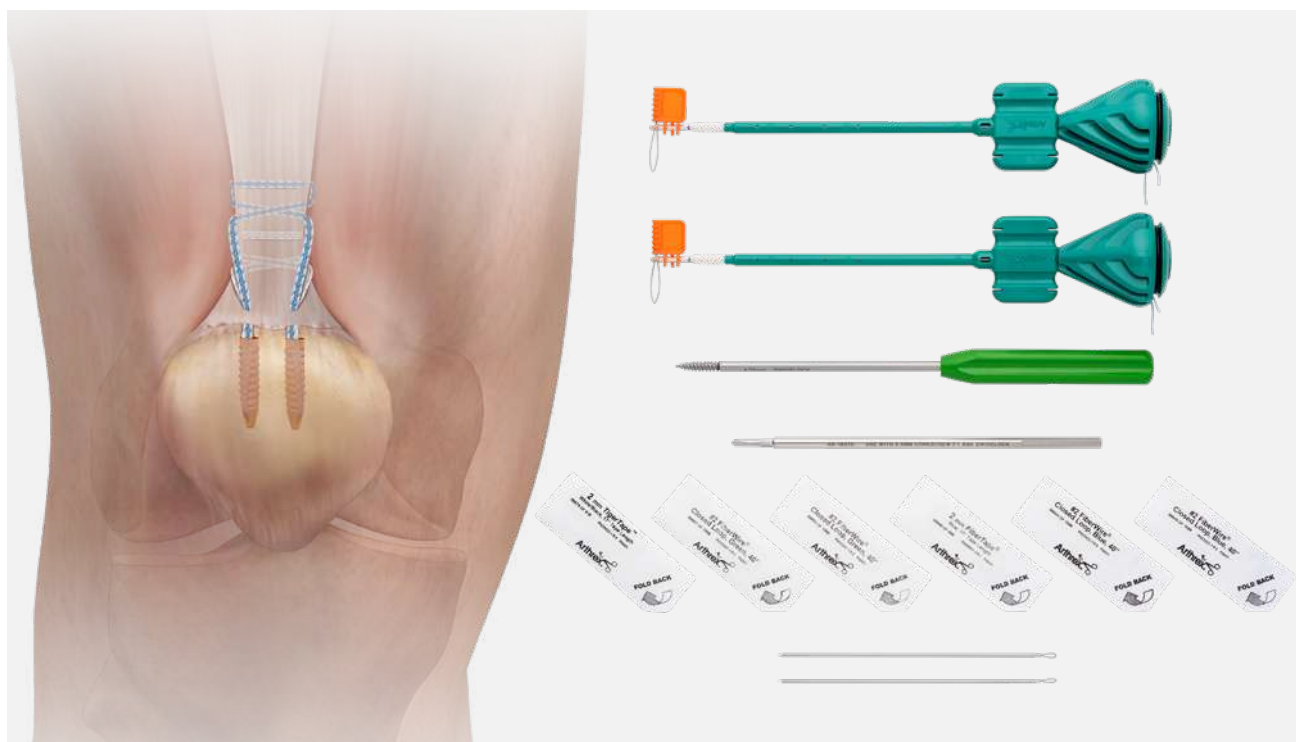

Ruptures of the quadriceps and patellar tendons are common in elite and recreational athletes. Most surgeons treat these injuries surgically to lessen the risk of long-term disability and morbidity. Historically, open techniques have been used for rupture repairs but may be complicated by wound-healing issues and infection. The minimally invasive Percutaneous Achilles Repair System (PARS) technique can be used to treat quadriceps, patellar, and Achilles tendon ruptures.

The PARS system helps facilitate consistently reliable capture of the distal aspect of the quadriceps tendon and includes color-coded FiberWire and FiberTape sutures. The anatomically contoured guide is reusable, while the suture and passing needles come packaged in a convenient kit. The PARS system provides the option of using transverse or locking sutures or both. The colored FiberWire sutures offer a more organized approach to identifying and securing matched pairs.

PARS Jig Instrument Set (AR-8860S)

Product Description	Item Number
PARS jig	AR-8860J
PARS tendon elevator	AR-8860J-01
Driver handle, AO connection, cannulated	AR-13221AOC
PARS repair instrument case	AR-8860C

Implants / Instruments

Product Description	Item Number
#2 FiberTape® suture, blue, 96.5 cm	AR-7237-7
#2 FiberTape® suture, white / black, 96.5 cm, qty. 2	AR-7237-7T
#2 FiberTape® suture, blue, 101.6 cm, with loops, qty. 2	AR-7235
#2 FiberTape® suture, green, 101.6 cm, with loops	AR-7209SN
2 Eye needles, qty. 2	3180
Drill, spade tip	AR-1927D
One Punch / tap	AR-2324PTB
SwiveLock® anchor, BioComposite, 4.75 mm, qty. 2	AR-2324BCC

Meniscal Repair

FiberStitch™ All-Inside Meniscal Repair.....	76
Meniscal Cinch™ II.....	76
ZoneNavigator™ System.....	77
Meniscal Repair Needles.....	77
Knee Scorpion™ Suture Passer	78
Meniscal Root Marking Hook.....	78
Meniscal Root Repair.....	79
Meniscal Repair and Resection Set.....	79
QuickPass™ SutureLasso™ for Meniscal Ramp Lesions.....	80
Micro SutureLasso™.....	80
Meniscal Repair Accessories	81
Meniscal Viper™	81
Protector™ – Inside-Out Suture Repair	81

FiberStitch™ All-Inside Meniscal Repair

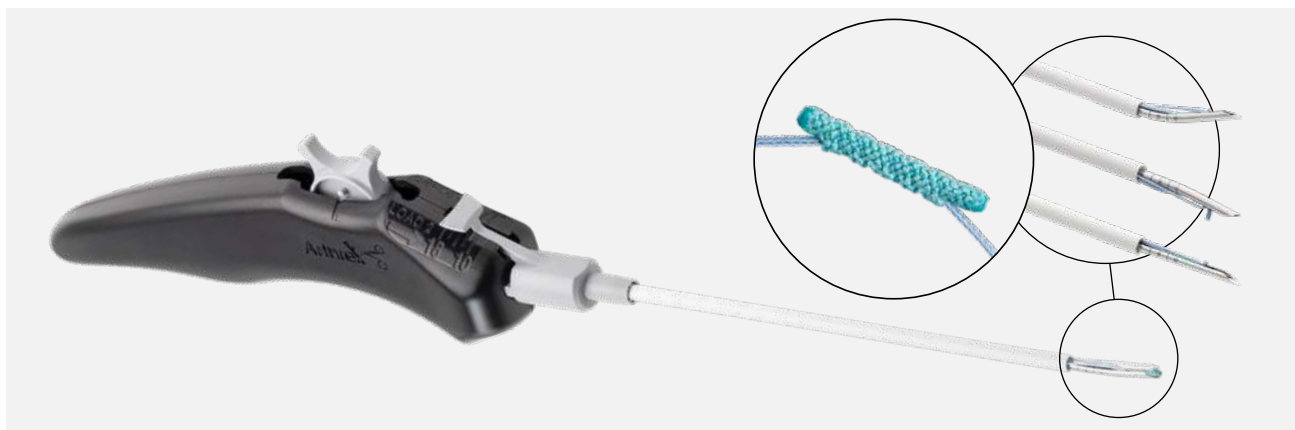

The FiberStitch implant is an innovative all-inside meniscal repair system that replaces hard PEEK implants with soft suture sheaths. The FiberStitch delivery system offers 4 different tip curves to accommodate various meniscus tear configurations: 12° up curve, 24° up curve, 12° reverse curve, and straight. A #2-0 coreless FiberWire® suture and a pretied sliding knot provide secure arthroscopic all-suture meniscus repair. The ergonomic handle is designed for single-handed implant delivery and active implant deployment technology minimizes needle exposure beyond the meniscus, eliminating the need to past-point the needle.

Product Description	Item Number
FiberStitch™ implant, 12° up curved	AR-4570
FiberStitch™ implant, 24° up curve	AR-4570-24
FiberStitch™ implant, 12° reverse curve	AR-4570R
FiberStitch™ implant, straight	AR-4570S
Accessories	
Knot pusher / suture cutter, with portal skid	AR-5845
Portal skid	AR-4505
Knot pusher / suture cutter	AR-5815
Portal skid, reusable	AR-6506LP
#2-0 suture cutter, straight, Ø 2.75 mm, with FlushPort	AR-11790F
#2-0 suture cutter, 15° up, Ø 2.75 mm, with FlushPort	AR-11791F
Arthroscopic measurement probe, 60°, 220 mm	AR-4070-01
Meniscus repair rasp	AR-4130
Probe hook, 150 mm shaft, 3.4 mm tip, with 5 mm markings	AR-10010

Meniscal Cinch™ II



The Meniscal Cinch II implant system combines the best technology for actively delivering and deploying low-profile implants during all-inside meniscal repair. The linear actuation delivers small 1 mm × 5 mm PEEK implants secured with coreless #2-0 FiberWire suture and a pre-tied Weston sliding knot. The implants are actively deployed through a small perforation, reducing trauma to surrounding tissue.

Product Description	Item Number
Meniscal Cinch™ II	AR-4501
Meniscal Cinch™	AR-4500

ZoneNavigator™ System

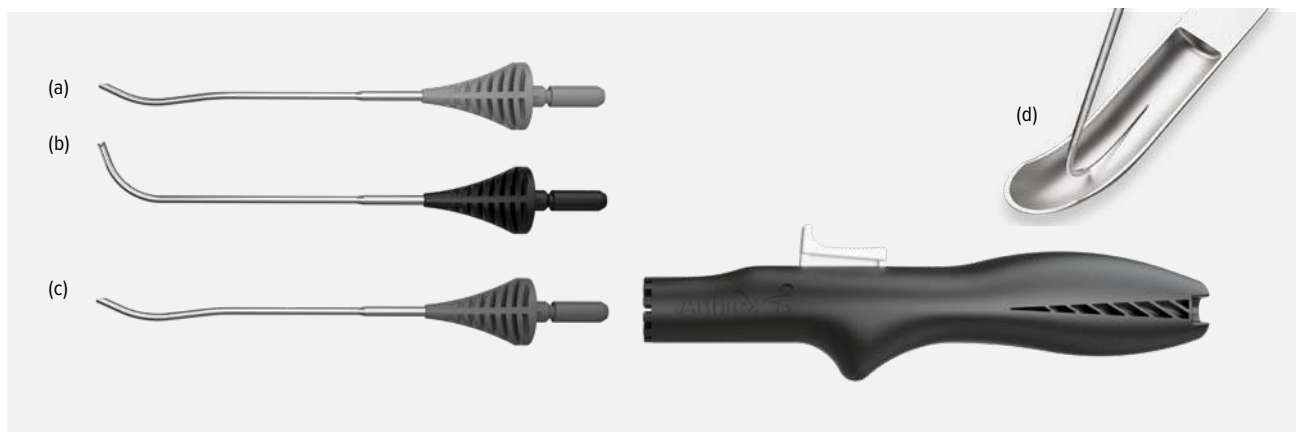

The ZoneNavigator system precisely places suture for inside-out meniscal repair. Three interchangeable cannulas are available to reach any portion of the meniscus to pass vertical or horizontal mattress sutures on the superior or inferior aspect of the meniscus. The ergonomic handle controls needle advancement in 1 cm increments.

Product Description	Item Number
ZoneNavigator™ system handle	AR-7900
ZoneNavigator™ system anterior cannula (a)	AR-7905
ZoneNavigator™ system cannula, left posterior (b)	AR-7910L
ZoneNavigator™ system cannula, right posterior (c)	AR-7910R
Needle catcher (d)	AR-6660

Mini SutureTape

Product Description	Item Number
#2-0 Mini SutureTape meniscal repair needles, qty. 2	AR-7523

Meniscal Repair Needles



The FiberWire suture meniscal repair needles are made of standard-length stainless steel with a 96.5 cm length of #2-0 FiberWire suture or Mini SutureTape. The Mini SutureTape disperses the compressive force across a larger area compared to round suture. This allows surgeons to perform standard inside-out meniscal repair with all the benefits of FiberWire suture and SutureTape.

Product Description	Item Number
#2-0 Mini SutureTape meniscal repair needles	AR-7523
#2-0 Mini SutureTape, no needles	AR-7521
#2-0 FiberWire® suture meniscal repair needles, qty. 2	AR-7223
#2-0 FiberWire® suture meniscal repair needles, small, qty. 2	AR-7223SM

Knee Scorpion™ Suture Passer



The low-profile Knee Scorpion suture passer allows access in tight recesses of the knee for passing #0 and #2-0 FiberWire suture or 0.9 mm Mini SutureTape. Ergonomically designed for 1-handed use, the Knee Scorpion suture passer adds simplicity to suture passing, efficiently passing and retrieving suture in 1 step. Achieve a variety of suture configurations for soft-tissue repair and fixation using the Knee Scorpion suture passer.

Product Description	Item Number
Scorpion™ suture passer, knee	AR-12990
Needles, for Scorpion™ suture passer, knee	AR-12990N

Mini SutureTape

Product Description	Item Number
FiberLink™, SutureTape, white / blue, 0.9 mm, with closed loop	AR-7559
TigerLink™, SutureTape, white / black, 0.9 mm, with closed loop	AR-7559T

Meniscal Root Marking Hook



The meniscal root marking hook offers adjustable, posterior tibia-referencing root repair for transosseous bone preparation with the FlipCutter II drill. The “over-the-back” hook and ratcheting drill sleeve provide 2-point fixation and guided stability during drilling. The locking mechanism aids with insertion into the joint and the low-profile design avoids intact anatomy, while allowing arthroscopic visualization of the repair site. The guide offers 3 offsets for bone socket preparation: 5, 7.5, or 10 mm from the posterior tibia. The guide can be rotated for optimal tunnel position and subsequent knotless fixation with a button or SwiveLock anchor.

Product Description	Item Number
Locking guide	AR-1610LG
Meniscal root marking hook	AR-1610MR

Meniscal Root Repair



Complete transtibial meniscal root repairs with the convenient meniscal root repair kits, which contains an 8 mm × 3 mm PassPort Button cannula and a Knee Scorpion needle for passing #2-0 and #0 FiberWire suture with the autoclavable Knee Scorpion suture passer. Various suture configurations are possible with #2-0 FiberStick and #0 FiberLink and TigerLink sutures. Easily shuttle suture using the nitinol wire in the 2.4 mm-diameter SutureLasso needle. Prepare the bone socket and create the transtibial tunnel using the 6 mm FlipCutter II reamer. Secure the repair with a 4.75 mm PEEK SwiveLock anchor or with a 2-hole suture button.

Meniscal Root Repair Kit With PEEK SwiveLock® Anchor (AR-4550P)

Product Description	Item Number
Knee Scorpion™ needle	AR-12990N
FlipCutter® II reamer, 6 mm	AR-1204AF-60
PassPort Button™ cannula, 8 mm × 3 cm	AR-6592-08-30
#2-0 FiberStick™ sutures, qty. 2	AR-7222
SutureLasso™ needle, with nitinol passing wire	AR-4560
#0 FiberLink™ suture	AR-7258
#0 TigerLink™ suture	AR-7258T
PEEK SwiveLock® anchor, 4.75 mm × 19.1 mm	AR-2324BCC
Drill bit, spade tip	AR-1927D
SwiveLock® anchor tap, for hard bone	AR-1593-5

Meniscal Root Repair Kit (AR-4550)

Product Description	Item Number
Knee Scorpion™ needle	AR-12990N
FlipCutter® II reamer, 6 mm	AR-1204AF-60
PassPort Button™ cannula, 8 mm × 3 cm	AR-6592-08-30
#2-0 FiberStick™ sutures, qty. 2	AR-7222
SutureLasso™ needle, with nitinol passing wire	AR-4560
Suture button, 2-hole, 3.5 mm	AR-8920
#0 FiberLink™ sutures, qty. 2	AR-7258
Optional Accessories	
SutureLasso™ needle, qty. 1	AR-4560-1
SutureLasso™ needle, qty. 5	AR-4560

Meniscal Repair and Resection Set



The meniscal repair and resection set contains the most popular instruments for addressing various meniscus procedures including meniscal root repair, all-suture meniscal repair, and meniscal contouring. The instruments are held securely within the slotted silicone pads for protection. A removable shelf uncovers an open space for placement of additional instrumentation.

Meniscal Repair and Resection Instrument Set (AR-4555S)

Product Description	Item Number
Meniscal root marking hook	AR-1610MR
Locking guide, for meniscal root marking hook	AR-1610LG
Knee Scorpion™ suture passer	AR-12990
Mini suture retriever, straight, 2.75 mm	AR-11540F
Mini suture retriever, 15° up curved, with FlushPort	AR-11550F
MegaBiter™ resector, straight	AR-41006
MegaBiter™ resector, up-curved	AR-41026
MegaBiter™ resector, straight left	AR-41006L
MegaBiter™ resector, straight right	AR-41006R
Hook probe, 3.4 mm	AR-10010
Meniscal repair rasp	AR-4130
RetroConstruction™ handle, side release	AR-1510HR
Drill sleeve, for side-release handle, ratcheting, 2.4 mm	AR-1510FD-24
Stepped drill sleeve, for side-release handle, ratcheting	AR-1510FS-7
Guide pin sleeve, for stepped drill sleeve, 2.4 mm	AR-1204F-24I

QuickPass™ SutureLasso™ for Meniscal Ramp Lesions



A meniscal ramp lesion is a disruption of the meniscotibial ligament and the posteromedial meniscus in the meniscocapsular zone. The QuickPass SutureLasso can be used via a posteromedial portal. It is anatomically, 25° curved with a 1.5 mm tip to precisely and safely treat the location of the ramp lesion. The SutureLasso is pre-loaded with a #2-0 FiberStick and is available in 2 versions, right and left.

Product Description	Item Number
QuickPass™ SutureLasso™ suture passer, 25°, curved left	AR-6068-25L
QuickPass™ SutureLasso™ suture passer, 25°, curved right	AR-6068-25R

Micro SutureLasso™

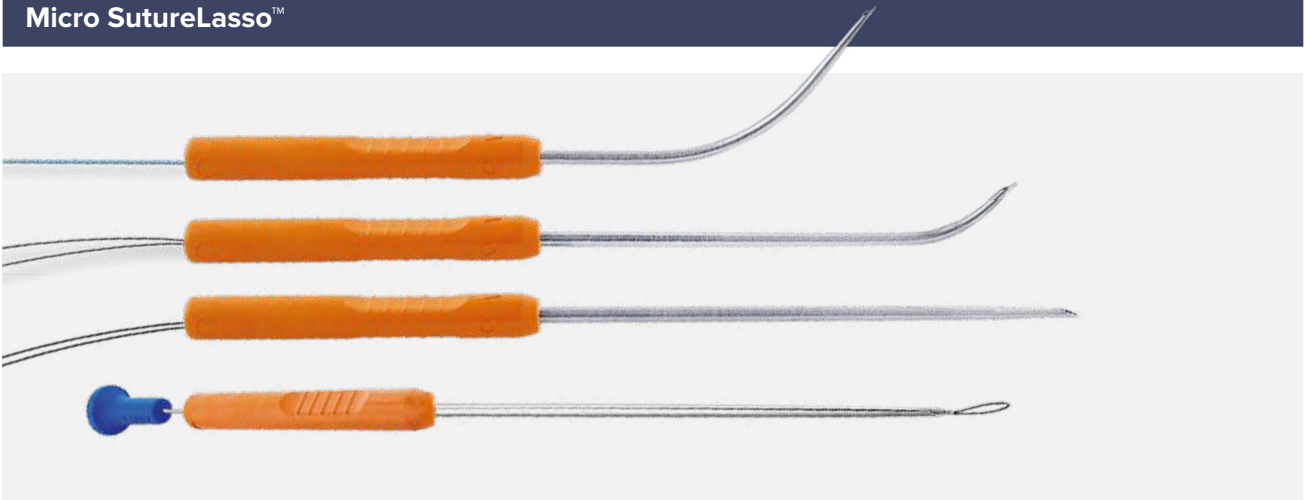

The Micro SutureLasso instrument, a 15 cm-long cannulated stainless steel shaft with an ergonomic handle, facilitates the placement of simple mattress stitches to repair various meniscal tears using an outside-in approach. These strong, stainless steel needles come preloaded with a braided nitinol wire to be used as a suture shuttle and are available in small-curve, large-curve, and straight configurations for accessing hard-to-reach areas. As an alternative, all FiberSticks can be passed along the Micro SutureLassos with ease.

Product Description	Item Number
Micro SutureLasso™	
Micro SutureLasso™, minor bend	AR-8701
Micro SutureLasso™, major bend	AR-8702
Micro SutureLasso™, straight	AR-8703
Suture retriever, for SutureLasso™, sterile	AR-8701SR
Optional Accessories	
FiberStick™, #2 FiberWire®, blue, 127 cm, one end stiffened, 30 cm	AR-7209
#2 TigerStick®, #2 TigerWire®, white / black, 127 cm, one end stiffened, 30 cm	AR-7209T
#2-0 Mini SutureTape, no needles	AR-7521
#2-0 FiberStick™, #2-0 FiberWire®, blue, 127 cm, one end stiffened, 30 cm	AR-7222
SutureLasso™ needle, qty. 1	AR-4560-1
SutureLasso™ needle, qty. 5	AR-4560

Meniscal Repair Accessories



Use the malleable Meniscal Dart measuring probe to measure the width of the meniscus. The angled tip of the meniscus repair rasp is ideally shaped to access inside the meniscal tear for debridement prior to the repair. The malleable portal skid can be used to clear access into the knee joint and can be bent for anatomical customization.

Product Description	Item Number
Arthroscopic measurement probe, 60° (a)	AR-4070-01
Arthroscopic measurement probe, 70°	AR-4070-70S
Meniscal repair rasp (b)	AR-4130
Probe hook, 3.4 mm tip, 150 mm shaft, with 5.0 mm markings	AR-10010
Portal skid (c)	AR-4505

Meniscal Viper™



The sterile meniscal Viper repair kit provides a method of passing suture to repair posterior horn meniscal tears. Each sterile kit contains a meniscal Viper pre-loaded with #2-0 FiberWire and a small knot pusher.

Product Description	Item Number
Meniscal Viper™ repair kit, small, disposable	AR-13920DS
Meniscal Viper™ repair kit, medium, disposable	AR-13930DS
Accessories	
Meniscal repair rasp	AR-4130
Suture cutter, 15° up curved, #2-0 suture only, reusable	AR-11791F
Shoehorn cannula, 6 mm ID × 9 cm, qty. 5	AR-6565

Protector™ – Inside-Out Suture Repair



The Protector meniscal suturing set provides a safe, versatile system to perform either inside-out or all-inside meniscal suturing. The malleable, single-use curved cannula and integrated plastic handle has a nitinol needle and a needle pusher for convenience.

Protector™ Meniscal Suturing Kit (AR-4060S)

Product Description	Item Number
Cannula, malleable, curved, with handle	----
Needle, nitinol, with wire loop	AR-1291S
Needle holder, adjustable	----
Accessories	
Needle catcher (a)	AR-6660
Cannula bending tool	AR-6650
#2-0 Mini SutureTape, no needles (recommended suture)	AR-7521

Meniscectomy Hand Instruments

Arthroscopic Meniscectomy Instrument Set	84
MegaBiter™ Tissue Resection Series	85
Nano Instruments	85

Arthroscopic Meniscectomy Instrument Set

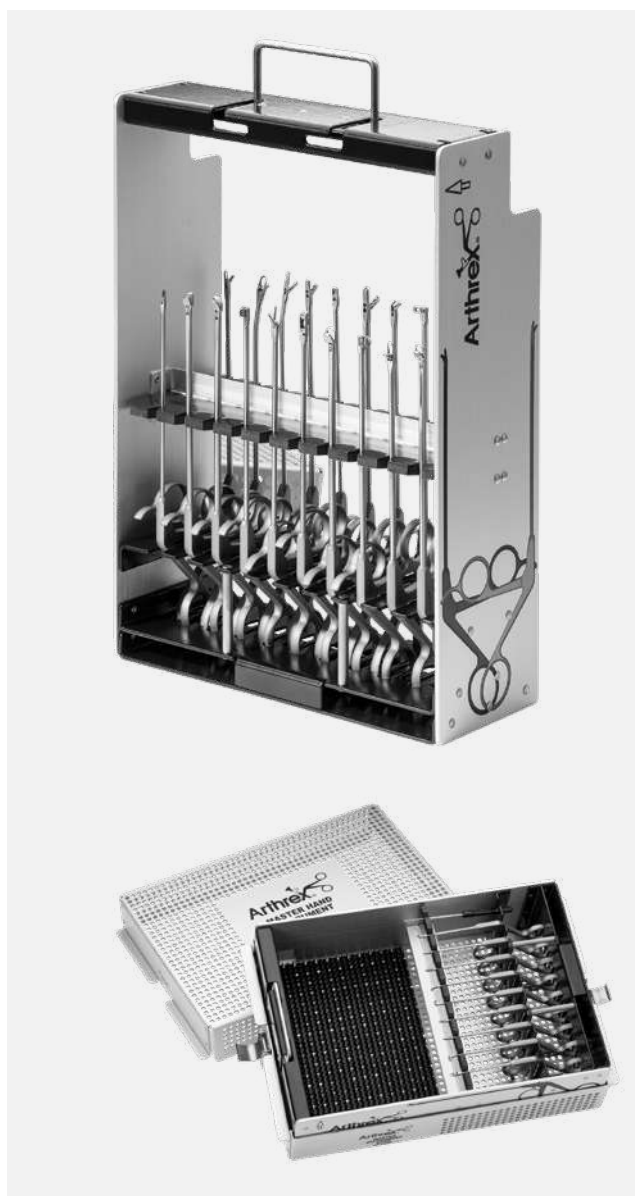

The lightweight Arthroscopic Meniscectomy Instrument set contains the most popular hand instruments. The anodized aluminum case can safely store up to 20 arthroscopy instruments, which are held securely in slotted silicone pads with the tips in the open position for protection and easy identification.

Arthroscopic Meniscectomy Instrument Set (AR-2200CS)

Product Description	Item Number
Probe, hook, Ø 3.4 mm tip, with 5 mm markings	AR-10010
Punch, slender straight tip, straight shaft, Ø 2.75 mm	AR-11100F
Punch, large straight tip, straight shaft, Ø 2.75 mm	AR-11200F
Grasper, mini straight tip, 15° up curved shaft, Ø 2.75 mm, with NR handle	AR-11910NRF*
Punch, standard straight tip, straight shaft, Ø 3.4 mm	AR-12000F
Scissors, serrated tooth straight tip, straight shaft, Ø 3.4 mm	AR-12140F
WideBiter™ punch, 15° up tip, 15° up curved shaft, Ø 3.4 mm	AR-12241
Grasper, blunt straight tip, straight shaft, Ø 3.4 mm, with NR handle	AR-12500NRF*
Punch, medium reverse straight tip, straight shaft, Ø 3.4 mm	AR-12530F
Punch, medium 45° right angled tip, straight shaft, Ø 3.4 mm	AR-12800F
Punch, medium 45° left angled tip, straight shaft, Ø 3.4 mm	AR-12810F
WideBiter™ punch, 90° right rotary tip, straight shaft, Ø 3.4 mm	AR-12912F
WideBiter™ punch, 90° left rotary tip, straight shaft, Ø 3.4 mm	AR-12913F
Punch, rotary with scoop 90° right tip, straight shaft, Ø 3.4 mm	AR-12940F
Punch, rotary with scoop 90° left tip, straight shaft, Ø 3.4 mm	AR-12950F
Grasper, alligator hook tip, straight shaft, Ø 4.2 mm, with NR handle	AR-13600NRF*
MegaBiter™ resector, straight tip, 5.5 mm × 2.5 mm	AR-41006
MegaBiter™ resector, up curved tip, 5.5 mm × 2.5 mm	AR-41026
MegaBiter™ resector, straight tip, left cut, 5.5 mm	AR-41006L
MegaBiter™ resector, straight tip, right cut, 5.5 mm	AR-41006R
Hand instrument case, 20 slots	AR-2200C

* SR graspers are available upon request at no additional charge.

MegaBiter™ Tissue Resection Series



The MegaBiter resector has transformed meniscal resection with its large, 5.5 mm bite width. Its low-profile design helps reach tight recesses in joint spaces. The straight MegaBiter resector provides the same bite width without the curved tip, allowing access to tissue in tighter joint spaces. The open, slotted shaft allows easy and efficient instrument cleaning and does not require a FlushPort connection.

Product Description	Item Number
MegaBiter™, straight jaw, 5.5 mm × 2.5 mm (a)	AR-41006
MegaBiter™, curved jaw, 5.5 mm × 2.5 mm (b)	AR-41026
MegaBiter™, straight shaft, left cut, 5.5 mm (c)	AR-41006L
MegaBiter™, straight shaft, right cut, 5.5 mm (d)	AR-41006R

Nano Instruments

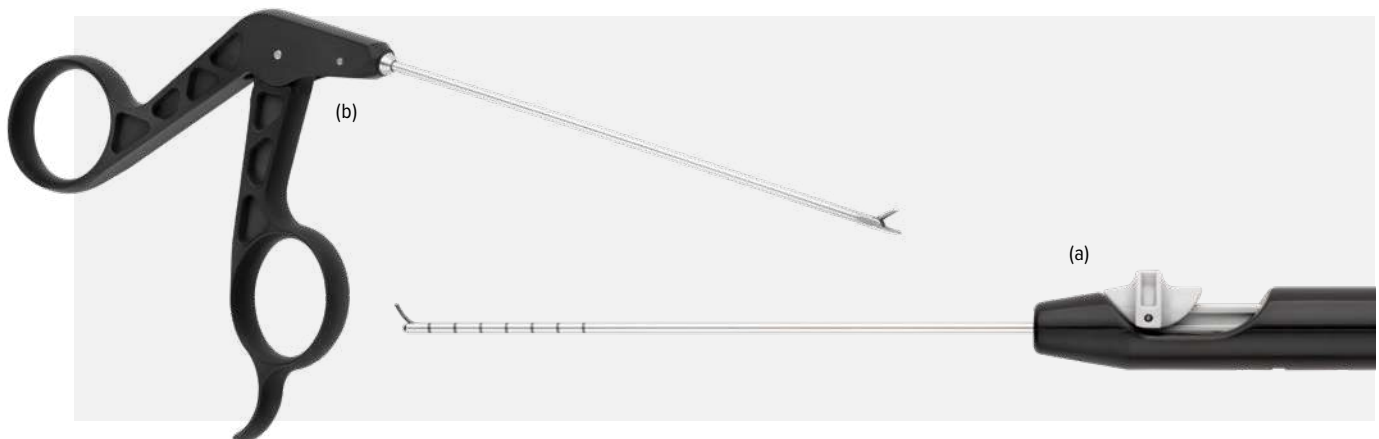

Harnessing 20 years of engineering excellence in designing arthroscopic hand instrumentation, Arthrex has produced the next generation in tissue resection and extraction instruments that are sharp and strong enough to resect and remove meniscal tissue. The low-profile tip design facilitates safe introduction into most tight joint spaces without the need for a limb holder.

Product Description	Item Number
NanoScope™ probe (a)	AR-10100N
NanoGrasper, straight, disposable, 130 mm (b)	AR-10913D-1
NanoScissor, straight, disposable, 130 mm	AR-10915D-1
NanoBiter, straight, disposable, 130 mm	AR-10911D-1
NanoBiter, 15° up, disposable, 130 mm	AR-10922D-1

Osteochondral Repair

Marrow Stimulation	88
PowerPick™ Microfracture Instruments	88
IntraOsseous BioPlasty®	89
Chondral Dart™ Implant.....	90
Osteochondral Flap Repair System.....	90
3 mm Bio-Compression Screw	91

Marrow Stimulation



These angled chondro picks are designed to perforate the surface of osteochondral defects. Tips hardened with titanium nitride provide visual 3 mm depth control during defect perforation. Delrin endcaps permit use of a mallet to assist in perforation.

Chondro Pick Kit (AR-1760S)

Product Description	Item Number
Chondro pick, 20°	AR-1761
Chondro pick, 40°	AR-1762
Chondro pick, 60°	AR-1763
Chondro pick, 25°, curved tip	AR-1764
Chondro pick, 35°, curved tip	AR-1765
Chondro pick instrument case	AR-1766

PowerPick™ Microfracture Instruments



The PowerPick and PowerPick XL, which were developed for the APS II shaver system, provide a fast and easy method for performing microfracture procedures. The PowerPick has a drill depth of 4 mm and the PowerPick XL's drill depth is 6 mm. All PowerPick versions have a working length of 13 cm and a drill diameter of 1.5 mm. The PowerPick is available with tip angles of 30 and 45 degrees, while the PowerPick XL features a 45-degree tip angle.

Product Description	Item Number
PowerPick™ microfracture instruments, 30°	AR-8150PP-30
PowerPick™ microfracture instruments, 45°	AR-8150PP-45
PowerPick™ XL, 45°, Ø 1.5 mm × 13 cm	AR-8150PX-45
APS II Shaver System	
APS II console	AR-8300
APS II footswitch, standard	AR-8310
APS II shaver handpiece, with foot control	AR-8330F
APS II shaver handpiece, hand-controlled	AR-8330H
Optional	
APS II multifunction footswitch, wireless	AR-8315
APS II multifunction footswitch, corded	AR-8315C

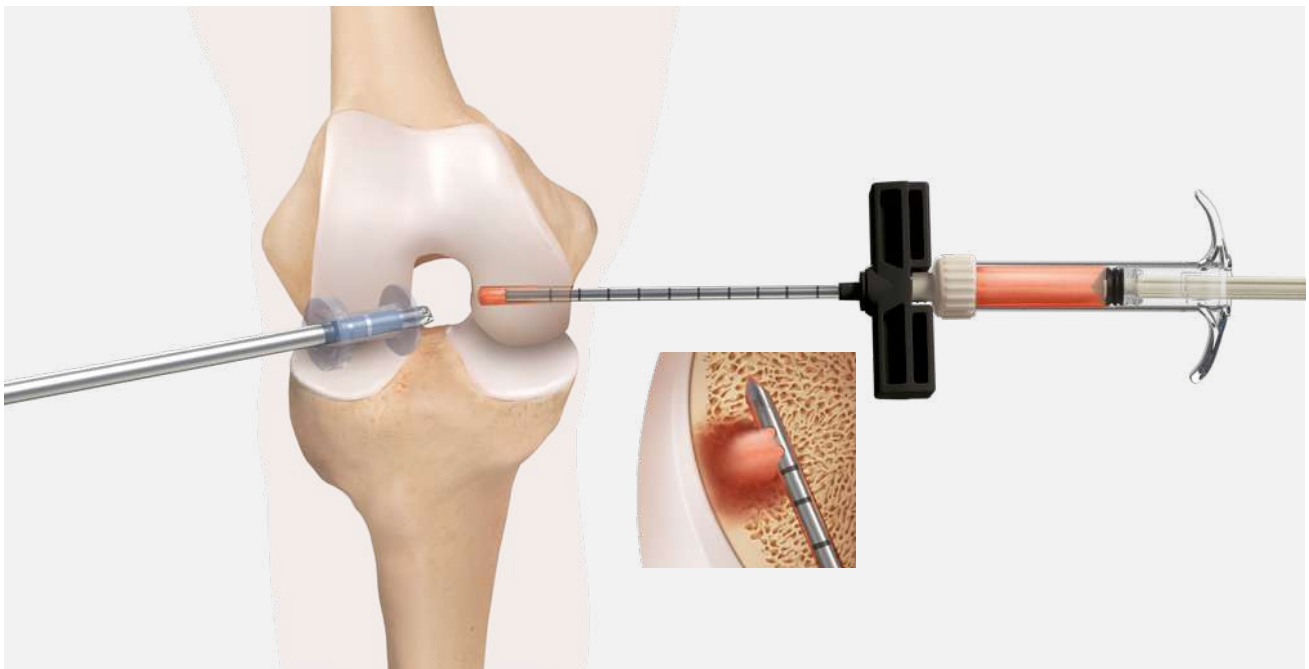

The IntraOsseous BioPlasty (IOBP) procedure is a biologic treatment for bone pathologies resulting from acute or chronic injury, including bone marrow lesions associated with insufficiency fracture, osteoarthritis, persistent bone bruises, avascular necrosis, and osteonecrosis. Arthrex offers multiple options for the biologic treatment of these pathologies, including decompressing the lesion and the delivery of a concentrated dose of platelet-rich plasma concentrate from bone marrow aspirate (cPRPBMA) using the Angel cPRP and bone marrow processing system. The IOBP technique is intended to encourage physiologic bone remodeling and repair to achieve normal bone anatomy and function.

Product Description	Item Number
Delivery needle, open tip, 8 G × 11 cm	RAN-811-OT
Delivery needle, closed tip, 8 G × 11 cm	RAN-811-CT
Delivery needle, open tip, 8 G × 15 cm	RAN-815-OT
Anticoagulant ACD-A 20 ml	SAAV222.G00
Arthrex ACP® double-syringe system	ABS-10014
Angel® system	ABS-10066

Chondral Dart™ Implant



The bioabsorbable PLLA Chondral Dart has a unique, double-reversed barbed design to facilitate fixation and compression of osteochondral flap tears up to 2 cm in diameter. The 18 mm long, 1.3 mm diameter Chondral Dart provides secure fixation under the hyaline cartilage surface, eliminating contact with sensitive articulating surfaces. Chondral Darts are an ideal complement to Bio-Compression screws for larger osteochondral defects. The placement instruments are included in the osteochondral flap repair system.

Product Description	Item Number
Chondral Dart™, 1.3 mm × 18 mm, sterile, qty. 5	AR-4005B-18

Osteochondral Flap Repair System



These instruments compress osteochondral fragments when inserting darts below the surface of the articular cartilage for strong, bioabsorbable fixation of smaller osteochondral flaps of 5 - 20 mm in diameter. Depending on the size of the defect, either a single or multi-shot instrument can be used.

Osteochondral Flap Repair Single-Shot Kit

Product Description	Item Number
Single-shot sheath, for osteochondral flap repair	AR-4009S
Single-shot dart inserter, for osteochondral flap repair	
Single-shot drill, for osteochondral flap repair	
Cannula, for osteochondral flap repair	

Osteochondral Flap Repair Multi-Shot Kit

Product Description	Item Number
Single-shot sheath, for osteochondral flap repair	AR-4095S
Single-shot dart inserter, for osteochondral flap repair	
Single-shot drill, for osteochondral flap repair	
Cannula, for osteochondral flap repair	
Guide pin, for osteochondral flap repair	
Guide sleeve, 2-hole, for osteochondral flap repair	
Guide sleeve, 4-hole, for osteochondral flap repair	
Guide pins, for osteochondral flap repair, S, M, L, and XL	

3 mm Bio-Compression Screw



For fracture and osteotomy fixation in periarticular applications, this screw offers interfragmentary compression and a headless profile.

3 mm Bio-Compression Screw Instrumentation Set (AR-5025S)

Product Description	Item Number
Bio-Compression screwdriver, noncannulated, 2.7 mm	AR-5025DB
Small handle, with AO connection	AR-2001AOT
Bio-Compression screw dilator tap, 20 mm	AR-5025TB
Bio-Compression screwdriver guide, 20 mm	AR-5025G
Bio-Compression screw drill bit, 20 mm	AR-5025TD
Bio-Compression dilator tap, cannulated, 16 mm	AR-5025TBC-16
Bio-Compression dilator tap, cannulated, 18 mm	AR-5025TBC-18
Bio-Compression dilator tap, cannulated, 20 mm	AR-5025TBC
Bio-Compression dilator tap, cannulated, 22 mm	AR-5025TBC-22
Bio-Compression dilator tap, cannulated, 24 mm	AR-5025TBC-24
Bio-Compression dilator tap, cannulated, 26 mm	AR-5025TBC-26
Bio-Compression screw drill bit, cannulated, 16 mm	AR-5025TDC-16
Bio-Compression screw drill bit, cannulated, 18 mm	AR-5025TDC-18
Bio-Compression screw drill bit, cannulated, 20 mm	AR-5025TDC
Bio-Compression screw drill bit, cannulated, 24 mm	AR-5025TDC-24
Bio-Compression screw drill bit, cannulated, 26 mm	AR-5025TDC-26
Bone-reduction forceps, with teeth	AR-4160FT
Depth device, cannulated	AR-5025DG
Bio-Compression screw instrumentation case	AR-5025C

Implants (Noncannulated)

Product Description	Item Number
Bio-Compression screw, 3 - 3.7 mm × 16 mm	AR-5025B-16
Bio-Compression screw, 3 - 3.7 mm × 18 mm	AR-5025B-18
Bio-Compression screw, 2.7 - 3.7 mm × 20 mm	AR-5025B-20
Bio-Compression screw, 3 - 3.7 mm × 22 mm	AR-5025B-22
Bio-Compression screw, 3 - 3.7 mm × 24 mm	AR-5025B-24
Bio-Compression screw, 3 - 3.7 mm × 26 mm	AR-5025B-26
Disposable	
Guide wire, with trocar tip, 1.1 mm	AR-5025K*
Optional	
Bio-Compression screw instrumentation case	AR-5025C

* Necessary for procedure; order separately.

Osteochondral Transplant

Single-Use OATS® System.....	94
Retrograde OATS™ System	95
Bone Graft Harvesting From the Iliac Crest.....	95

Single-Use OATS® System

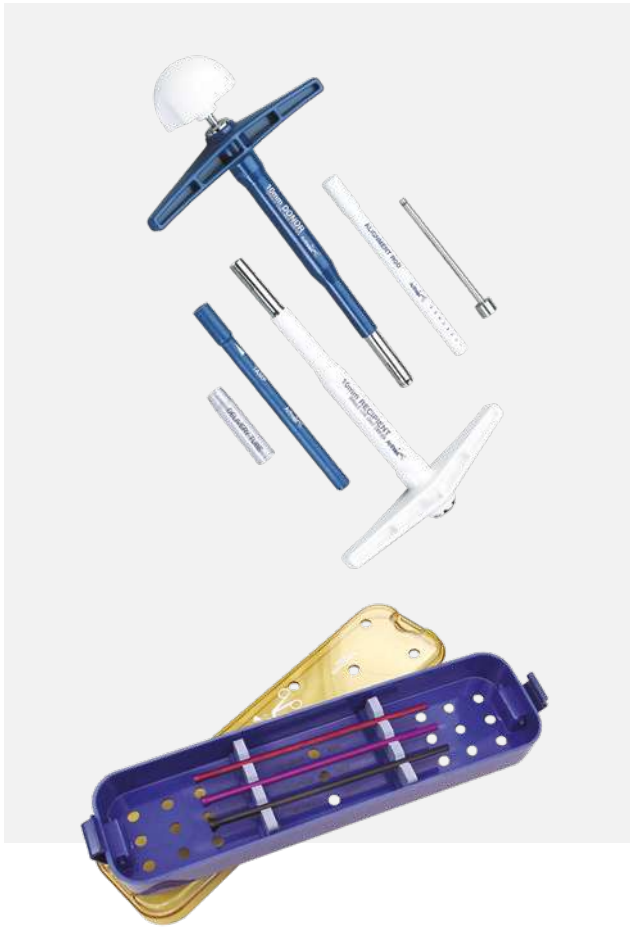

The sterile, single-use Osteochondral Autograft Transfer System (OATS) facilitates harvesting of 6, 8, and 10 mm osteochondral / hyaline cartilage cylinders from a donor site superior and lateral to the notch or above the sulcus terminalis. Create a recipient socket, sized to the appropriate depth, in the chondral defect to accept the donor graft. The bone cylinder can be visualized through the clear graft delivery tube while it is inserted with the collared pin delivery system for press-fit fixation. The completely disposable, size-specific system includes: Recipient harvester, donor harvester, alignment rod, tamp, graft delivery tube, core extruder for controlled push-in core insertion, and optional graft driver.

All of the system components are provided sterile, packaged in a rigid thermo-formed tray, and nestled in individual compartments.

Single-Use OATS® System

Product Description	Item Number
OATS® set, 4.75 mm, single-use	AR-1981-04S
OATS® set, 6 mm, single-use	AR-1981-06S
OATS® set, 8 mm, single-use	AR-1981-08S
OATS® set, 10 mm, single-use	AR-1981-10S

Optional

Product Description	Item Number
OATS® sizer / tamps set, 6, 8, and 10 mm (AR-1985S)	
Sizer / tamp, red, 6 mm	AR-1985-06
Sizer / tamp, purple, 8 mm	AR-1985-08
Sizer / tamp, black, 10 mm	AR-1985-10
OATS® sizer / tamps instrument case	AR-1985C

Retrograde OATS™ System



Rely on the retrograde OATS set to harvest precisely angled 8 and 10 mm osteochondral hyaline cartilage cylinders for resurfacing lesions in the tibial plateau and patella. Create an appropriately sized recipient tunnel retrograde to the lesion site. Measure the tunnel's articular surface and harvest the appropriate size and angle bone cylinder from a donor site above the sulcus terminalis. Exchange the cylinder from 1 donor harvester to another, enabling the bone cylinder to be implanted into the recipient tunnel, leading with the articular surface. Gently extrude the bone cylinder into the recipient tunnel slightly countersunk to the articular surface. Use a bioabsorbable interference screw to achieve final flush seating and backup to the press-fit fixation.

The size-specific system includes 2 single-use OATS harvesters; collared pins in 10°, 20°, and 30° angles; bone core exchange tube; guide pin; size-specific cannulated drills; and core extruder.

All system components are provided sterile, packaged in a rigid thermoformed tray, and nestled in individual compartments.

Retrograde OATS™ Set, 10 mm (AR-1982-10S)

Product Description	Item Number
OATS® marking hook	AR-1510M

Bone Graft Harvesting From the Iliac Crest



The single-use bone graft harvester set comprises a 6, 8, or 10 mm-diameter bone graft harvester, a punch, and a twist knob. The system is used for the minimally invasive harvesting of bone from the iliac crest for preparation as bone-filling material for opening osteotomies.

Product Description	Item Number
Bone graft harvester, 6, 8, and 10 mm	AR-1981-06H to -10H

Osteotomies

PEEKPower™ Osteotomy Plate.....	98
ContourLock™ HTO.....	99
ContourLock™ DFO.....	99
ContourLock™ – Tibial and Femoral Osteotomy System	100
Osteotomy – Fracture Management.....	101
iBalance® Implants and Anchors.....	102
iBalance® HTO.....	103
iBalance® HTO FreeCut Technique.....	103
Hinge Pin Instrumentation	104
INNOTERE Paste-CPC.....	105
INNOTERE 3D Scaffolds.....	105

PEEKPower™ Osteotomy Plate



PEEK (polyetheretherketone) as a high-performance polymer unites high mechanical stability and stiffness with excellent biocompatibility. The use of PEEK in combination with endless carbon and tantalum fibers in a fiber composite leads to revolutionary mechanical properties with higher long-term stability. The PEEKPower osteotomy plates are fixed to the bone with titanium screws. PEEKPower offers the possibility to angle the locking screws up to 24° followed by subsequent fixation of the screw head in the plate. Resterilizable x-ray templates of the plates facilitate the positioning of the plates before the implants are unpacked.

Saw Blade for DrillSaw Max 600™

Product Description	Item Number
Thickness 1.27 mm, length 105 mm, width 19 mm	AR-600-312S
Thickness 1.27 mm, length 90 mm, width 25.4 mm	AR-600-305S
Thickness 1.27 mm, length 90 mm, width 13 mm	AR-600-301S
Thickness 0.8 mm, length 65 mm, width 18 mm	AR-600-352S
Thickness 0.6 mm, length 45 mm, width 9 mm	AR-600-353S

Product Description	Item Number
Plates	
PEEKPower™ HTO plate (a)	AR-13401L
PEEKPower™ LDFO plate, left	AR-13402L
PEEKPower™ LDFO plate, right (b)	AR-13402R
Screws	
PEEKPower™ osteotomy locking screws, 5 mm × 16 - 90 mm Length: 16, 20, 24, 26, 28, 30, 32, 34, 36, 40, 42, 44, 46, 48, 50, 55, 60, 65, 70, 75, 80, 85, 90 mm	AR-13416T to -13490T
PEEKPower™ HTO compression screw, 4.5 mm × 24 - 52 mm Length: 24, 28, 32, 36, 40, 44, 48, 52 mm	AR-13524T to -13552T
PEEKPower™ HTO locking screw, 5 mm × 16 - 90 mm, sterile Length: 16, 20, 24, 26, 28, 30, 32, 34, 36, 38, 40, 42, 44, 46, 48, 50, 55, 60, 65, 70, 75, 80, 85, 90 mm	AR-13416TS to -13490TS
PEEKPower™ cortical screw, nonlocking, 4.5 mm × 24 - 52 mm, sterile Length: 24, 28, 32, 36, 40, 44, 48, 52 mm	AR-13524TS to -13552TS
Templates	
PEEKPower™ template, HTO plate	AR-13401LT
PEEKPower™ template, LDFO plate, left	AR-13402LT
PEEKPower™ template, LDFO plate, right	AR-13402RT
Hinge Pin Instrumentation	
HTO hinge pin set	AR-13315S
Template, HTO hinge pin	AR-13330
Extramedullary Instruments	AR-13440-01 / -02
Case, for EM instruments	AR-13330C3

Instrument Set for PEEKPower™ HTO Plate (AR-13421S)

Product Description	Item Number
Osteotome, 10 - 25 mm Width: 10, 15, 20, 25, 30 mm	AR-13421W-10 to -30
Bone spreader, for HTO	AR-1340T
Aiming adapter, tibial head	AR-1340DGA
Shortened aiming adapter tibial head	AR-1341DGA
Drill, for PEEKPower™ HTO locking screws, Ø 4.3 mm	AR-1340D
Drill guide, for PEEKPower™ HTO plate locking screws	AR-1340DG
Depth gauge, for PEEKPower™ HTO plate	AR-1340G
Drill, for cortical screws, Ø 3.2 mm	AR-1343.2D
Drill guide, for cortical screws	AR-1343DG
Screwdriver, for PEEKPower™ HTO plate	AR-13435D
Driver handle, AO connection	AR-13421AO
Bone block template, for opening wedge osteotomy	AR-13315
Trial wedge, for opening wedge osteotomy	AR-13324
AO adapter, cannulated	AR-4160AOC
Osteotomy guide pin, 2.4 mm	AR-13303-2.4
Guide wire, with trocar tip, 1.57 mm	AR-8941K
Retractor, radiolucent	AR-13311
PEEKPower™ HTO DFO instrument case	AR-13421C

EM instrumentation works only in conjunction with iBalance arthroplasty instrumentation as follows: AR-623-30 / -31 / -32 / -33

ContourLock™ HTO



The titanium tibial opening wedge osteotomy plates and screws, designed to work in conjunction with the standard opening wedge osteotomy instrumentation, enable the surgeon to anchor presterilized 6.5 mm cancellous or 4.5 mm cortical screws at stable angles using clamping rings.

Product Description	Item Number
Plates	
ContourLock™ HTO plate, flat, left, 67 mm	AR-13730-01
ContourLock™ HTO plate, flat, left, 71 mm	AR-13730-02
ContourLock™ HTO plate, flat, left, 84 mm	AR-13730-03
ContourLock™ HTO plate, flat, right, 67 mm	AR-13735-01
ContourLock™ HTO plate, flat, right, 71 mm	AR-13735-02
ContourLock™ HTO plate, flat, right, 84 mm	AR-13735-03
Screws	
Cancellous screws, for HTO plate, 6.5 mm × 35 - 70 mm Length: 35, 40, 45, 50, 55, 60, 65, 70 mm	AR-13280-35 to -70
Cancellous screws, for HTO plate, 4.5 mm × 26 - 60 mm Length: 26, 28, 30, 32, 34, 36, 38, 40, 42, 44, 46, 48, 50, 52, 54, 56, 58, 60 mm	AR-13380-26 to -60

ContourLock™ DFO



The ContourLock femoral osteotomy plate is designed to work in conjunction with the standard opening wedge osteotomy instrumentation, enabling the surgeon to anchor presterilized 6.5 mm cancellous or 4.5 mm cortical screws within the plate itself. The PEEKPower femoral osteotomy plate is designed to work in conjunction with the 5 mm titanium locking screws according to the PEEKPower system.

Product Description	Item Number
ContourLock™ DFO plate, right, small / medium	AR-13110R-01
ContourLock™ DFO plate, right, large / extra large	AR-13110R-02
ContourLock™ DFO plate, left, small / medium	AR-13110L-01
ContourLock™ DFO plate, left, large / extra large	AR-13110L-02

ContourLock™ – Tibial and Femoral Osteotomy System

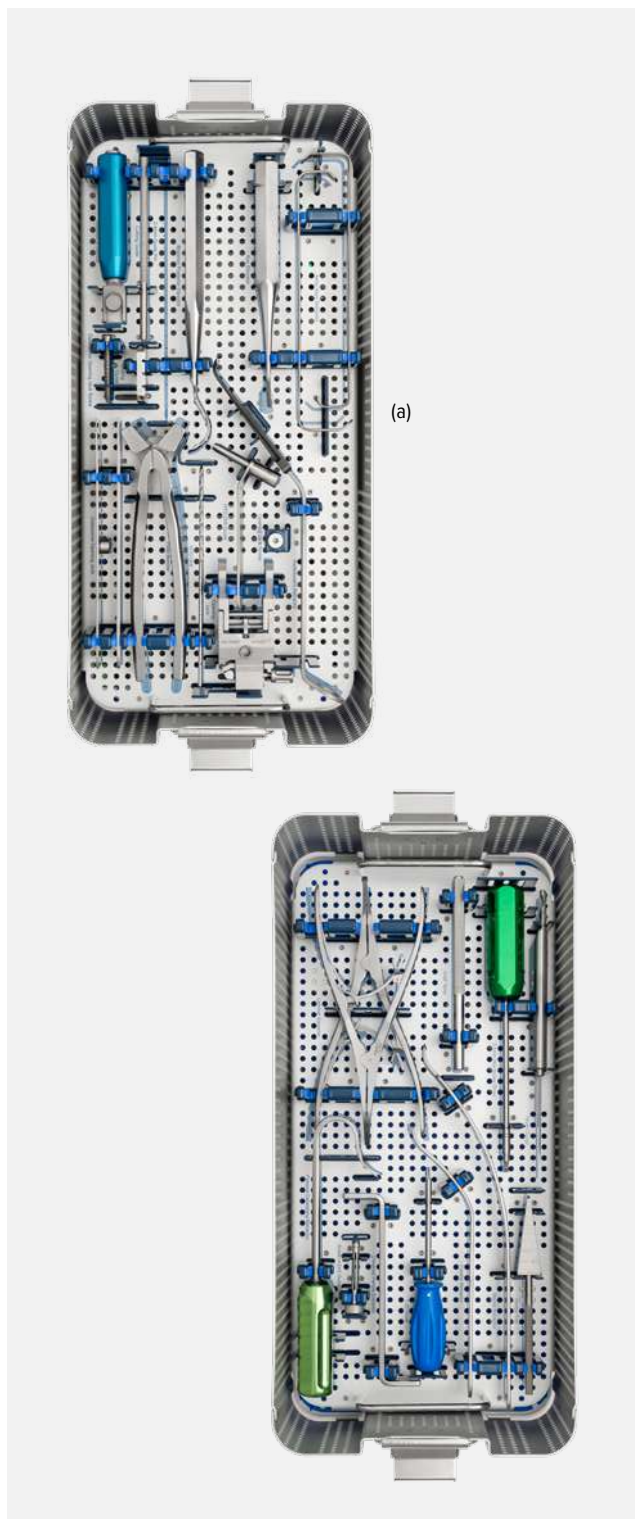

The opening wedge osteotomy system for ContourLock titanium implants offers a comprehensive instrument set for high tibial osteotomies and distal femoral osteotomies, each for opening osteotomy techniques.

Product Description	Item Number
Osteotomy set, tibial	AR-13330TS
Osteotomy set, femoral (a)	AR-13330S
Accessories (Optional, Not Included in the Set)	
Handle, ratcheting, AO connection	AR-8950RH
Anchor drill, AO connection	AR-13434-02
Graft tamp	AR-13432
Cobb elevator	AR-13411-01
Osteotomy jack, 35 mm	AR-13323-35
All Sets Include a Handle for Osteotomes, Disposable Blades Available Separately	
Osteotome blade, flexible, 10 mm	AR-13302F-10
Osteotome blade, flexible, 25 mm	AR-13302F-25
Osteotome blade, flexible, 35 mm	AR-13302F-35
Multiple-Use Osteotomes	
Osteotome blade, 10 mm	AR-13421W-10
Osteotome blade, 15 mm	AR-13421W-15
Osteotome blade, 20 mm	AR-13421W-20
Osteotome blade, 25 mm	AR-13421W-25
Osteotome blade, 30 mm	AR-13421W-30
Additional Instruments (Not Part of the Set)	
AO osteotomy wedge	AR-13300
AO guide pin, 3 mm	AR-13303-3.0
AO parallel guide positioning instrument	AR-13304-1
Guide sleeve, for parallel pin	AR-13304-2
AO C-ring drill guide	AR-13305
AO cutting guide	AR-13306-01
AO fixation pin, for cutting guide	AR-13306-02
Alignment rod, for axial determination	AR-13308
Application instrument, for opening wedge osteotomy plate	AR-13318
Universal plate bending pliers, for osteotomy plates	AR-13322-02
Osteotomy jack callipers	AR-13323G
Measuring device, for osteotomy plates, L, with A/P slope	AR-13325L
Measuring device, for osteotomy plates, S, with A/P slope	AR-13325S
Screwdriver, 90°, 3.5 mm hex	AR-13326-90

Osteotomy – Fracture Management



This 2-pilot hole plate is the perfect support for a fractured lateral tibial cortex during HTO procedures as well as supporting the anteromedial tibial cortex during slope-changing HTO procedures. The plate can easily be slightly bent to conform to variations in bone anatomy using universal bending irons from the opening wedge osteotomy system set. It is fixed to the bone with 4 mm × 30 mm titanium cancellous screws.

Product Description	Item Number
Osteotomy support plate implant system, 2 pilot hole	AR-13215



The iBalance HTO system consists of nonabsorbable polyetheretherketone (PEEK) implants and anchors that are inserted in the osteotomy wedge to fix and maintain the medially opening proximal tibial osteotomy during HTO procedures. This system offers an alternative option to traditional metal plates and screws. The iBalance HTO implants and anchors remain in the bone, which is why in some cases second surgical procedures for implant removal due to overlying soft tissue irritation can be avoided. To promote bone healing and provide added stability, the suggested bone substitutes are OSferion osteotomy wedges (AR-13370-01 to -04).

iBalance® Implants

Product Description	Item Number
iBalance® HTO implant, SM 12°	AR-13400S-12
iBalance® HTO implant, SM 6° / MD 5°	AR-13400M-05
iBalance® HTO implant, SM 7° / MD 6°	AR-13400M-06
iBalance® HTO implant, SM 8° / MD 7°	AR-13400M-07
iBalance® HTO implant, SM 9° / MD 8°	AR-13400M-08
iBalance® HTO implant, SM 10° / MD 9°	AR-13400M-09
iBalance® HTO implant, SM 11° / MD 10°	AR-13400M-10
iBalance® HTO implant, SM 13° / MD 11°	AR-13400M-11
iBalance® HTO implant, SM 14° / MD 12°	AR-13400M-12
iBalance® HTO implant, SM 15° / MD 13°	AR-13400M-13
iBalance® HTO implant, MD 14°	AR-13400M-14
iBalance® HTO implant, MD 15°	AR-13400M-15
iBalance® HTO implant, LG 5°	AR-13400L-05
iBalance® HTO implant, LG 6° / XL 5°	AR-13400L-06
iBalance® HTO implant, LG 7° / XL 6°	AR-13400L-07
iBalance® HTO implant, LG 8° / XL 7°	AR-13400L-08
iBalance® HTO implant, LG 9° / XL 8°	AR-13400L-09
iBalance® HTO implant, LG 10° / XL 9°	AR-13400L-10
iBalance® HTO implant, LG 11° / XL 10°	AR-13400L-11
iBalance® HTO implant, LG 12° / XL 11°	AR-13400L-12
iBalance® HTO implant, LG 13° / XL 12°	AR-13400L-13
iBalance® HTO implant, LG 14° / XL 13°	AR-13400L-14
iBalance® HTO implant, LG 15° / XL 14°	AR-13400L-15

iBalance® Anchors

Product Description	Item Number
iBalance® HTO anchor, cancellous bone, 20 - 32 mm Length: 20, 22, 24, 26, 28, 30, 32 mm	AR-13401-20 to -32
iBalance® anchor HTO, cortical bone, 24 - 52 mm Length: 24, 26, 28, 30, 32, 34, 36, 38, 40, 42, 44, 46, 48, 50, 52 mm	AR-13402-24 to -52

iBalance® HTO

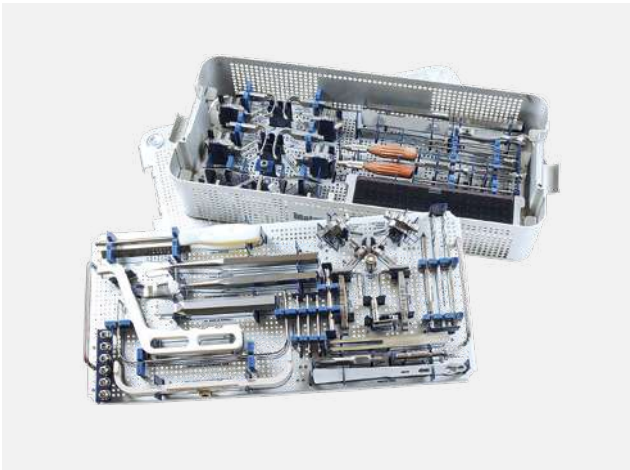

The iBalance HTO system is a specially designed set of instruments for the implantation of iBalance HTO wedges and anchors. The instrument set offers reproducible determination of the osteotomy plane, safe saw guidance, and protection against fracturing the opposite cortex.

Product Description	Item Number
iBalance® HTO instrument set	AR-13400S

iBalance® HTO FreeCut Technique



The iBalance HTO FreeCut technique allows the use of the iBalance implant in combination with standard HTO technique instrumentation. Specially designed instruments for the preparation of the keyhole help implant the iBalance implant flush into the bone. This allows the surgeon to transfer the advantages of the unique iBalance implant to the standardized HTO technique.

Specific Instruments

Product Description	Item Number
iBalance® instrument case	AR-13400C
Tibial osteotomy toolbox case	AR-13330C2
Driver handle, cannulated, with AO connection	AR-13221AOC
HTO retractor, radiolucent	AR-13310
Bone block template, for opening wedge osteotomy	AR-13315
Steel rule, 120 mm	AR-13410
Fastener and lock washer	AR-13413
Hex driver	AR-13415
Keyhole drill guide, L	AR-13417L
Keyhole drill guide, M	AR-13417M
Alignment handle	AR-13418
Osteotome, 10 - 25 mm	AR-13421W-10
Width: 10, 15, 20, 25, 30 mm	to -30
Keyhole reamer	AR-13425
Keyhole provisional pin	AR-13426
iBalance® anchor drill guide	AR-13433
Drill, for iBalance® anchor, chuck connection	AR-13434-01
Drill, for iBalance® anchor, AO connection	AR-13434-02
iBalance® anchor depth gauge	AR-13435
iBalance® anchor tap guide	AR-13436
Cortical bone tap, for iBalance® anchor, 4.5 mm	AR-13437
iBalance® anchor driver	AR-13439
AO adapter, cannulated	AR-4160AOC

Hinge Pin Instrumentation



The HTO hinge pin system offers a solution for any HTO system, regardless of the type of osteotomy, uniplanar or biplanar. The system offers:

- Determination of the endpoint of the osteotomy
- Saw cutting guide with lateral stop
- Reduced risk of fracture when folding open the osteotomy wedge

Guide pins with predetermined breakaway facilitate determination of the osteotomy plane.

Product Description	Item Number
HTO hinge pin set	AR-13315S
X-ray template, HTO hinge pin	AR-13330
Osteotomy guide pin, 2.4 mm	AR-13303-2.4
Osteotomy guide pin, 3 mm, qty. 6	AR-13303-3.0
Osteotomy guide pin, 2.4 mm, non-sterile, qty. 1	AR-13303-2.4-1
Osteotomy guide pin, 2.4 mm, sterile, qty. 1	AR-13303-2.4-1S
Osteotomy guide pin, 3 mm, non-sterile, qty. 1	AR-13303-3.0-1
Osteotomy guide pin, 3 mm, sterile, qty. 1	AR-13303-3.0-1S

INNOTERE Paste-CPC



INNOTERE Paste-CPC consists of biominerals and a non-aqueous carrier fluid. A calcium phosphate cement, corresponding to the mineral phase of the bone, is produced by successive insertion into the osteotomy gap. The biomaterial provides structural support through the complete filling of the osteotomy wedge and has a compressive strength of approximately 45 MPa.

Product Description	Item Number
INNOTERE Paste-CPC, 3 ml	111VX2

INNOTERE 3D Scaffolds

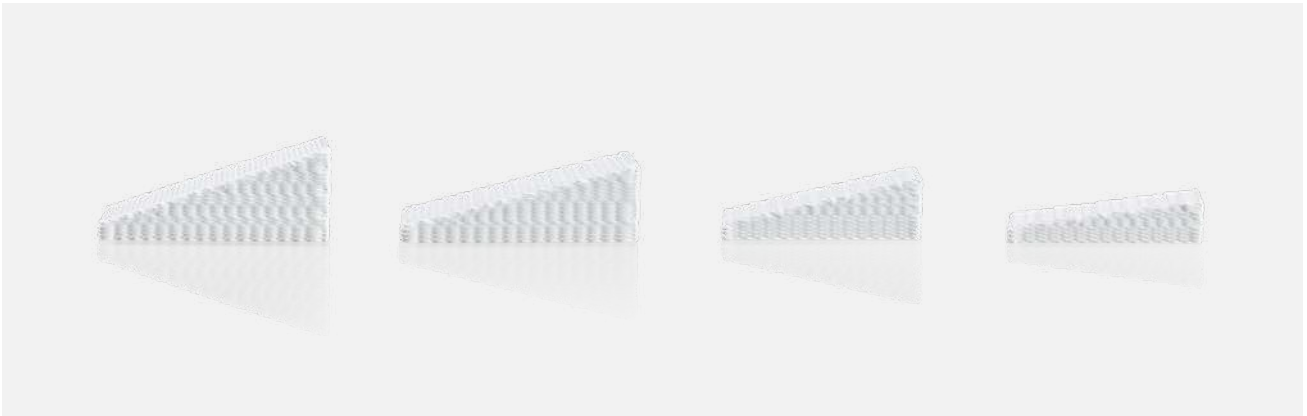

INNOTERE 3D Scaffold wedges consist of synthetically produced calcium phosphate that simulates the consistency of natural bone. These scaffolds offer a broad contact surface for opening osteotomies. They are radiolucent and can be combined with autologous fluids.

Product Description	Item Number
INNOTERE 3D Scaffold, for opening wedge osteotomy, 7 mm × 30 mm	721TS1
INNOTERE 3D Scaffold, for opening wedge osteotomy, 10 mm × 30 mm	721TS2
INNOTERE 3D Scaffold, for opening wedge osteotomy, 12 mm × 35 mm	721TS3
INNOTERE 3D Scaffold, for opening wedge osteotomy, 15 mm × 35 mm	721TS4

Fracture Management

Patella SuturePlate™ II, 3 mm System.....	108
Decompression Cannula	110

Patella SuturePlate™ II, 3 mm System



- Unidirectional locking system for the accurate reduction of patella fractures
- Innovative and safe system, especially for complex fractures
- Large variety to address different types of fractures
 - Special hook plate to treat distal pole fractures
 - Used with 3 mm low-profile locking screws
 - Additional 4 mm cannulated screw available
- Special suture holes allow soft tissue reattachment or ligament bracing

Implants (Titanium)

Product Description	Item Number
Plates	
Patella SuturePlate™ II, arrow	AR-13070A
Patella SuturePlate™ II, arrow, sterile	AR-13070A-S
Patella SuturePlate™ II, star, small	AR-13070S
Patella SuturePlate™ II, star, small, sterile	AR-13070S-S
Patella SuturePlate™ II, star, medium	AR-13070M
Patella SuturePlate™ II, star, medium, sterile	AR-13070M-S
Patella SuturePlate™ II, star, large	AR-13070L
Patella SuturePlate™ II, star, large, sterile	AR-13070L-S
Patella SuturePlate™ II, star, pole fracture, small	AR-13070S-P
Patella SuturePlate™ II, star, pole fracture, small, sterile	AR-13070S-P-S
Patella SuturePlate™ II, star, pole fracture, medium	AR-13070M-P
Patella SuturePlate™ II, star, pole fracture, medium, sterile	AR-13070M-P-S
Patella SuturePlate™ II, star, pole fracture, large	AR-13070L-P
Patella SuturePlate™ II, star, pole fracture, large, sterile	AR-13070L-P-S
Screws	
Locking screw, low profile, titanium, 3 mm × 10 - 22 mm	AR-8933L-10 to -22
Cannulated Screws	
QuickFix™ screw, cannulated shaft, titanium, cancellous, 4 mm × 40 - 60 mm	AR-8740-40PTS to -60PTS

» Please note that all implants above are also available sterile. All sterile item numbers end with an additional "S" if not otherwise stated.

Patella SuturePlate™ II Set (AR-13070PS)

Product Description	Item Number
Common Instruments 3 mm System	
Patella repositioning clamp	AR-13055
Positioning handle	AR-14024
Bending guide, locking, 3 mm	AR-8950-09
Temporary compression device, cannulated	AR-14023TDC
Driver handle, cannulated, with AO connection	AR-13221AOC
Depth guide, mini	AR-13120G-2
Driver, for 3 mm locking screws, T10 hexalobe	AR-8944DH
Drill bit, 2 mm	AR-8944-22
Drill guide, locking, threaded, 3 mm	AR-8950-07
Patella SuturePlate™ II instrument case	AR-13070C
Patella SuturePlate™ II screw caddy (must be ordered separately)	AR-13070SC
Instruments for Cannulated Screws	
Guide wire, with trocar tip, Ø 1.35 mm	AR-8737-01
Guide wire, with trocar tip, threaded, Ø 1.35 mm	AR-8737-02
Depth guide, cannulated, 4 mm	AR-8737-10
Drill guide, 2.5 mm / 1.35 mm	AR-8943-03
Drill bit, cannulated, for QuickFix™ screws, T15 hexalobe, 2.5 mm	AR-8737-09-RU
Holding sleeve, for 2.7, 3.5, and 4 mm screws	AR-8943-11
Cleaning stylet, 4 mm	AR-8737-20

Trial Plates

Product Description	Item Number
Trial patella SuturePlate™ II, arrow	AR-13070A-T
Trial patella SuturePlate™ II, star, small	AR-13070S-T
Trial patella SuturePlate™ II, star, medium	AR-13070M-T
Trial patella SuturePlate™ II, star, large	AR-13070L-T
Trial patella SuturePlate™ II, star, pole fracture, small	AR-13070S-P-T
Trial patella SuturePlate™ II, star, pole fracture, medium	AR-13070M-P-T
Trial patella SuturePlate™ II, star, pole fracture, large	AR-13070L-P-T

Disposables

Product Description	Item Number
K-wire, 1.6 mm × 150 mm	AR-14016
BB-Tak, threaded	AR-13226T
BB-Tak, threaded, sterile	AR-13226TS

Literature

Product Description	Item Number
Patella SuturePlate™ II – 3 mm System surgical technique	LT2-00133-EN

Decompression Cannula



Depressed fractures such as tibia plateau fractures are challenging to treat. The surgical management includes percutaneous anatomic reduction and stable fixation to ensure early mobilization and minimal surgical trauma.

The decompression cannula enables a convenient reduction of depressed fractures.

- **Diameter**
8 G – allows minimally invasive procedure
- **Bent shape**
Allows convenient access and reduction of the compression
- **Luer lock connection**
Allows connection of Luer lock syringes and cartridges
- **Plastic trocar**
Prevents damage and reduces dead space

Decompression Cannula

Product Description	Item Number
Instruments	
Cannula bending tool 8 G (4.3 mm) / 10 G (3.5 mm)	AR-6655
Headed reamer, cannulated, 5 - 11 mm	AR-1405 to 11
RetroConstruction™ drill guide handle, side release	AR-1510HR
Insert, 2.4 mm	AR-1204F-24I
Tibial ACL footprint	AR-1510T
Hook, multi-use	AR-1510M
Tissue protector	AR-2840-2
Bone Graft Substitute	
INNOTERE Paste-CPC, 3 cc	111VX2

Disposables

Product Description	Item Number
Decompression cannula	ABS-3300
Drill tip guide pin, 2.4 mm × 311 mm	AR-1250L-1
Drill tip guide pin, 2.4 mm × 311 mm, sterile	AR-1250LS

Literature

Product Description	Item Number
Decompression Cannula – Treatment of Depressed Tibial Plateau Fractures surgical technique	LT2-00075-EN



This description of technique is provided as an educational tool and clinical aid to assist properly licensed medical professionals in the usage of specific Arthrex products. As part of this professional usage, the medical professional must use their professional judgment in making any final determinations in product usage and technique. In doing so, the medical professional should rely on their own training and experience, and should conduct a thorough review of pertinent medical literature and the product's directions for use. Postoperative management is patient-specific and dependent on the treating professional's assessment. Individual results will vary and not all patients will experience the same postoperative activity level and/or outcomes.

View U.S. patent information at www.arthrex.com/corporate/virtual-patent-marking

arthrex.com

© Arthrex GmbH, 2021. All rights reserved. LB2-0115-EN_I

