

---

New as of: 08.2018

---



# inLab MC X5

## Operating Instructions

English



## Dear Customer,

Thank you for your purchase of this inLab MC X5<sup>®</sup> unit from Dentsply Sirona.

This device enables you to produce dental restorations, e.g. from ceramic material with a natural appearance (**CE**ramic **RE**Construction).

Improper use and handling can create hazards and cause damage. Please therefore read and follow these operating instructions carefully. Always keep them within easy reach.

Also pay attention to the safety instructions to prevent personal injury and material damage.

Your  
inLab MC X5 team

## Table of contents

<b>1</b>	General data .....	7
1.1	Contact information .....	7
1.2	General conventions and structure of the document .....	7
1.2.1	Structure of the document.....	7
1.2.1.1	Identification of the danger levels .....	7
1.2.1.2	Formats and symbols used .....	8
1.2.2	Notes to the repository .....	8
1.3	Scope of these Operating Instructions.....	8
1.4	Warranty and liability.....	9
1.5	Legend .....	9
<b>2</b>	General information on the device .....	11
2.1	Standards/ approvals/ certifications .....	11
2.2	Intended use .....	12
2.3	Scope of supply .....	12
2.4	Technical description (component and interfaces) .....	13
2.4.1	Major components .....	13
2.4.1.1	Front view .....	13
2.4.1.2	Connections.....	14
2.4.1.3	Processing chamber.....	16
2.4.2	Standard accessories .....	17
	.....	18
<b>3</b>	Safety information .....	19
3.1	Basic safety information.....	19
3.1.1	Prerequisites .....	19
3.1.2	Maintenance and repair .....	19
3.1.3	Modifications to the product.....	19
3.1.4	Accessories.....	20
3.1.5	In case of damage .....	20
3.2	Electromagnetic compatibility .....	20
3.2.1	Electromagnetic emission .....	20
3.2.2	Interference immunity .....	21
3.2.3	Working clearances .....	23
3.3	Electrostatic charge .....	24
3.3.1	ESD protective measures .....	24
3.3.2	About the physics of electrostatic charges.....	24
3.4	Connecting the unit.....	26

3.5	Connection of external equipment .....	26
3.6	Ventilation slots .....	26
3.7	Opening the processing chamber door .....	26
<b>4</b>	<b>Transportation and installation .....</b>	<b>27</b>
4.1	Transport and unpacking .....	27
4.2	Disposal of packaging materials .....	27
4.3	Installation conditions .....	28
4.3.1	Installation site requirements .....	28
4.3.2	Suction requirements .....	28
4.3.3	Filter regulator/ compressed air supply requirements .....	28
4.4	Connecting the suction device .....	29
4.5	Connecting the coolant tank .....	30
4.6	Connecting the filter regulator .....	32
4.7	Connecting the PC/interfaces .....	33
4.8	Repacking .....	33
4.9	Storage .....	33
<b>5</b>	<b>Commissioning .....</b>	<b>34</b>
5.1	Putting the inLab 4 PC into operation .....	34
5.1.1	Startup prerequisites .....	34
5.1.1.1	Required accessories .....	34
5.1.1.2	Making connections .....	36
5.1.2	Safety .....	37
5.1.3	Installing the software .....	38
5.2	Putting the unit into operation .....	39
5.2.1	Connecting the unit to the power supply .....	39
5.2.2	Checking the compressed air .....	39
5.2.3	Functional elements .....	39
5.2.3.1	Button assignment .....	39
5.2.3.2	Color status of the buttons and the processing chamber .....	40
5.2.4	Removing the transport safety device and putting the processing chamber into operation .....	41
5.2.5	Filling the coolant tank (for material classes PMMA/wax, composite and grinding materials) .....	42
5.2.6	Switching the unit ON and OFF .....	44
5.2.7	Installing and configuring the unit .....	45
5.2.7.1	Installing the unit .....	45
5.2.7.2	Configuring the device .....	46

<b>6</b>	<b>Operation .....</b>	<b>52</b>
6.1	Referencing run .....	52
6.2	Machining processes .....	53
6.2.1	Process types .....	53
6.2.1.1	Grinding .....	54
6.2.1.2	Milling .....	55
6.2.1.3	Wet processing.....	56
6.2.1.4	Dry processing.....	56
6.2.2	Tool magazine .....	57
6.2.2.1	Available tools .....	60
6.2.3	Equipping the multi-block holder.....	61
6.2.4	Loading with the workpiece (round blank) .....	63
6.2.5	Loading with the multi-block holder.....	65
6.2.6	Process start.....	67
<b>7</b>	<b>Maintenance and cleaning.....</b>	<b>68</b>
7.1	Care, cleaning agents, and disinfectants.....	68
7.2	Cleaning the unit with MC Care liquid.....	68
7.3	Maintenance intervals.....	69
7.4	Cleaning surfaces .....	70
7.4.1	Disinfecting .....	70
7.4.2	Protection against medicaments.....	70
7.4.3	Cleaning.....	70
7.5	Maintenance for the tool mandrel .....	71
7.5.1	Service kit .....	72
7.5.2	Cleaning and maintenance of the collet chuck / collet chuck change .....	72
7.5.3	During longer downtimes .....	75
7.5.4	Tool has broken or not been stored.....	75
7.6	Suction system.....	76
7.6.1	Suction bellows.....	76
7.6.2	Mandrel suction.....	76
7.6.3	Processing chamber screen .....	77
7.7	Filter regulator.....	77
7.8	Coolant system .....	78
7.8.1	Coolant nozzles .....	78
7.8.2	Changing the tank filter .....	79

7.8.3	Replace the coolant when using DENTATEC (for material classes PMMA/wax, composite and grinding materials).....	80
7.8.3.1	Preventing odors .....	80
7.8.3.2	Complete a coolant change.....	81
7.9	Procedure for processing sintering metal .....	83
7.9.1	Important information .....	83
7.9.2	Before processing sintering metal materials .....	84
7.9.3	After processing sintering metal materials .....	84
7.9.4	Cleaning the coolant tank .....	85
7.9.4.1	Emptying the cooling tank .....	85
7.9.4.2	Rinsing and emptying the water tank .....	85
7.9.5	Filling the coolant tank .....	86
7.10	Procedure when processing Medentika-PreFace® abutment semi-finished products made of titanium .....	87
7.10.1	Important information .....	87
7.10.2	Before processing titanium workpieces .....	88
7.10.2.1	Filling and connecting the coolant tank .....	88
7.10.2.2	Equipping the workpiece holder for Medentika-PreFace® semi-finished products .....	90
7.10.2.3	Loading inLab MC X5 with Medentika PreFace® holders.....	91
7.10.3	After processing / before changing to processing another material .....	94
7.10.3.1	Retrofitting the machine.....	94
7.10.3.2	Cleaning the drain sieve .....	96
7.10.3.3	Change the coolant .....	97
7.11	Replacing the main fuse .....	99
7.12	Error messages and measures .....	100
7.13	Consumables: .....	101
8	Dismantling and disposal.....	103
8.1	Dismantling and reinstallation .....	103
8.2	Disposal .....	103
	Index.....	104

# 1 General data

## 1.1 Contact information

### Customer service center

For technical questions, use the contact form on the internet at the following address:

<http://srvcontact.sirona.com>

### Manufacturer's address



Sirona Dental Systems GmbH  
Fabrikstrasse 31  
64625 Bensheim  
Germany

Tel.: +49 (0) 6251/16-0

Fax: +49 (0) 6251/16-2591

e-Mail: [contact@dentsplysirona.com](mailto:contact@dentsplysirona.com)

[www.dentsplysirona.com](http://www.dentsplysirona.com)

## 1.2 General conventions and structure of the document

### 1.2.1 Structure of the document

#### 1.2.1.1 Identification of the danger levels

To prevent personal injury and material damage, please observe the warning and safety information provided in these operating instructions. Such information is highlighted as follows:

#### **DANGER**

An imminent danger that could result in serious bodily injury or death.

#### **WARNING**

A possibly dangerous situation that could result in serious bodily injury or death.

#### **CAUTION**

A possibly dangerous situation that could result in slight bodily injury.

#### **NOTE**

A possibly harmful situation which could lead to damage of the product or an object in its environment.

#### **IMPORTANT**

Application instructions and other important information.

**Tip:** Information for simplifying work.

### 1.2.1.2 Formats and symbols used

The formats and symbols used in this document have the following meaning:

<ul style="list-style-type: none"> <li>✓ Prerequisite</li> <li>1. First action step</li> <li>2. Second action step</li> <li>or</li> <li>➤ Alternative action</li> <li>↔ Result</li> <li>➤ Individual action step</li> </ul>	Prompts you to do something.
See "Formats and symbols used [→ 8]"	Identifies a reference to another text passage and specifies its page number.
• List	Designates a list.
"Command / menu item"	Indicates commands / menu items or quotations.

### 1.2.2 Notes to the repository

It is mandatory to keep this operating manual in an easily accessible place for the purpose of later reference. In the event of a sale or transfer of the device to another user, make sure that the device is supplied along with the operating manual, so that the new owner can get acquainted with the operation and the appropriate precautions and warnings

## 1.3 Scope of these Operating Instructions

### Equipment options

This document describes the full version of your system. It may therefore cover components that are not included in the system you purchased.



## 1.4 Warranty and liability

### Maintenance

In the interest of the safety and health of patients, users or third parties, it is necessary that maintenance work is carried out at fixed time intervals to ensure the operational safety and reliability of your product.

The operator must ensure the implementation of the maintenance work.

As a manufacturer of electro-medical equipment, we can consider ourselves responsible for the safety characteristics of the device only if maintenance and repairs are carried out only by us or by companies authorized explicitly by us for this purpose and if components are replaced with original spare parts in case of failure.

### Exclusion of liability

If the operator does not meet the obligation to carry out such maintenance or fault messages are ignored, Sirona Dental Systems or its authorized dealer does not assume any liability for damage caused.

## 1.5 Legend



Year of manufacture

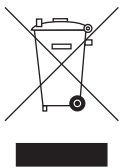

Product disposal symbol (see "Disposal [→ 103]").

### Accompanying documents



This symbol can be found on the rating plate on the unit.

Meaning: Observe the Operating Instructions when operating the unit.



This symbol can be found on the rating plate on the unit.

Meaning: The accompanying documents are available on the Sirona homepage.

### Electrostatic discharge (ESD)



Connector pins or sockets bearing ESD warning labels must not be touched or interconnected without ESD protective measures. See also "Electrostatic charge [→ 24]" and "Electromagnetic compatibility [→ 20]".

### Disconnection of the power supply during maintenance work

If the device-sided electronics box must be opened during maintenance work, this may be done only after disconnection of the power supply to the device.



### General danger notice



Observe the Operating Instructions.

### Symbols on the packaging

Take note of the following symbols on the packaging:



Top



Protect from moisture



Fragile; handle with care



Do not stack

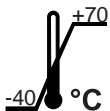

Temperature during storage and transport

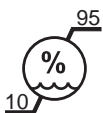

Relative humidity during storage and transport

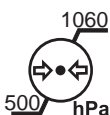

Air pressure during storage and transport

## 2 General information on the device

### 2.1 Standards/ approvals/ certifications



#### CE mark

This product bears the CE mark in accordance with the provisions of Council Directive 2006/42/EC (machinery directive). As such, the following standards apply: DIN EN ISO 12100:2011-03, DIN EN 61010-1:2011-07 and DIN EN 61326-1:2013-07.

#### CAUTION

##### CE mark for connected products

Further products which are connected to this unit must also bear the CE mark. These products must be tested according to the applicable standards.

Examples of CE mark for connected products:

- EN 60601-1:2006 based on IEC 60601-1:2005
- EN 60950-1:2006 based on IEC 60950-1:2005
- UL 60950 second edition 2010

#### EAC certification

Mark of conformity of the Eurasian Economic Community



#### GOST certification



#### RoHS compliance

This symbol indicates that this product does not contain any toxic or hazardous substances or components above the maximum concentration value set out in the Chinese standard SJ / T 11364-2014, and can be recycled following disposal and should not be carelessly discarded.



## 2.2 Intended use

The device creates computer-supported dentures using a milling or grinding process for work pieces or dental work from blanks in block or disc form.

Depending on the materials to be used, the process occurs in wet or dry operation.

This unit must not be used for any other purpose. If the unit is used for any purpose other than the one mentioned above, it may be damaged.

Intended use also includes compliance with these Operating Instructions and the relevant maintenance instructions.

### CAUTION

#### **Follow the instructions**

If the instructions for operating the unit described in this document are not observed, the intended protection of the user may be impaired.

### CAUTION

The device may only be operated with a proper cover.

#### **For the USA only**

**CAUTION:** Federal law (USA) restricts sale of this device to or on the order of a physician, dentist, or licensed practitioner.

#### **Dry processing**

### CAUTION

In the event of dry processing without suction, dust can be created from the materials being processed. Breathing in this dust can have associated health risks. As such, observe the information and requirements of the suction.

Dry processing is only permitted in conjunction with suction. We recommend the Sirona suction (230V: REF 6385129, 120V: REF 6485929). If you wish to use another type of suction, please observe the specific requirement information, (see "Suction requirements [-> 28]").

### **NOTE**

Before using dry processing, verify the functioning, correct connection and the tightness of the connections. All available suction openings must be available.

## 2.3 Scope of supply

The detailed scope of supply is specified in the document "Checklist".

## 2.4 Technical description (component and interfaces)

### 2.4.1 Major components

#### 2.4.1.1 Front view

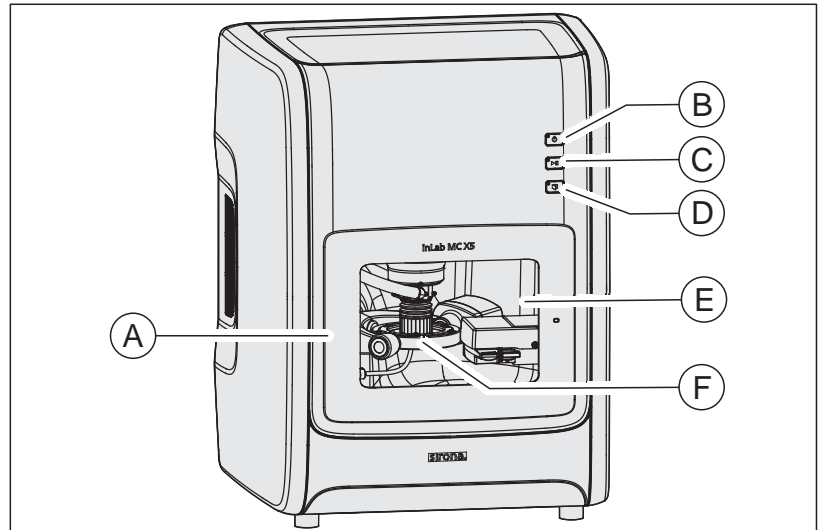

A	Processing chamber door	D	Door unlocking button
B	ON/OFF button	E	Processing chamber
C	Process start/ interrupt button	F	High-frequency mandrel

### 2.4.1.2 Connections

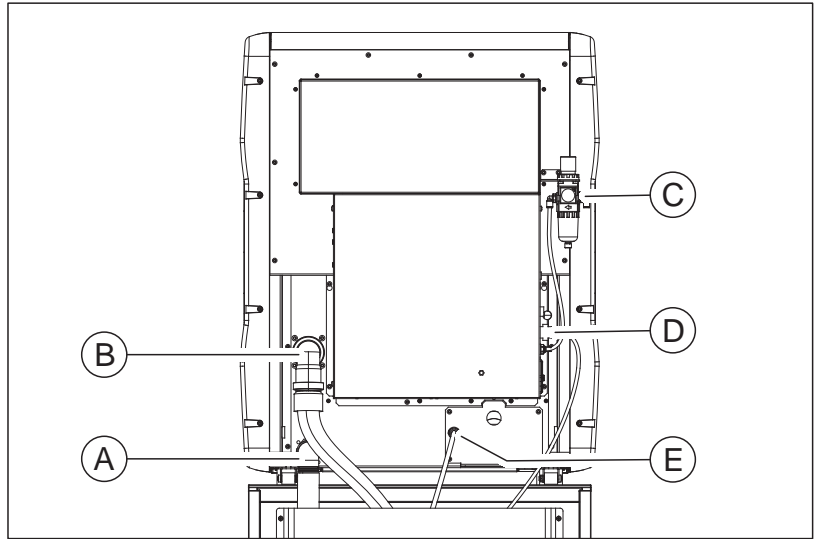

A	Coolant drainage connection	D	Communications interface for suction
B	Connection for suction	E	Coolant inlet connection
C	Filter regulator		

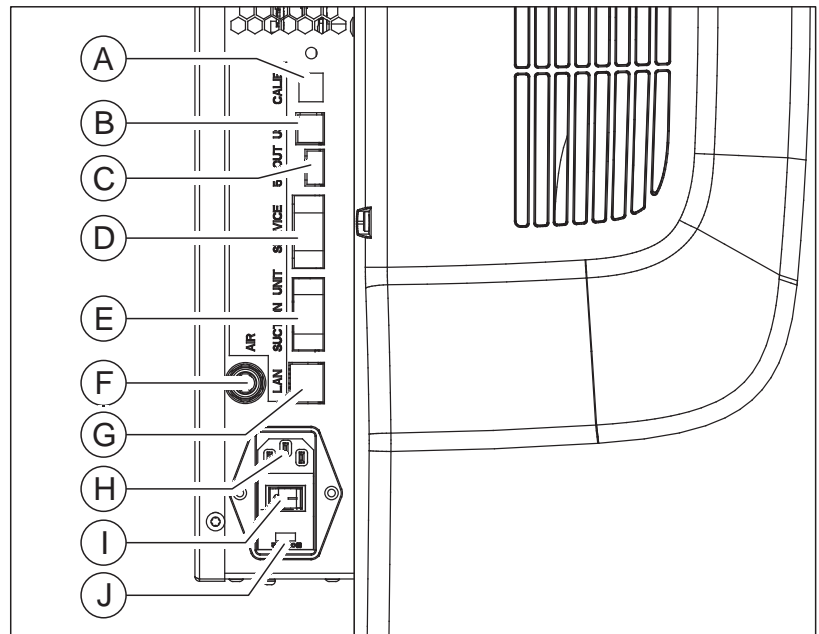

A	Service interface	F	Compressed air quick-connect coupling
B	USB 2.0/3.0	G	"Ethernet (RJ45)" connection for LAN
C	USB 5V OUT	H	Mains connection AC 100V ... 240V
D	Service interface	I	Device main switch ON/OFF
E	Communications interface for suction	J	Fuses F1/F2 T3.15A 500V

### 2.4.1.3 Processing chamber

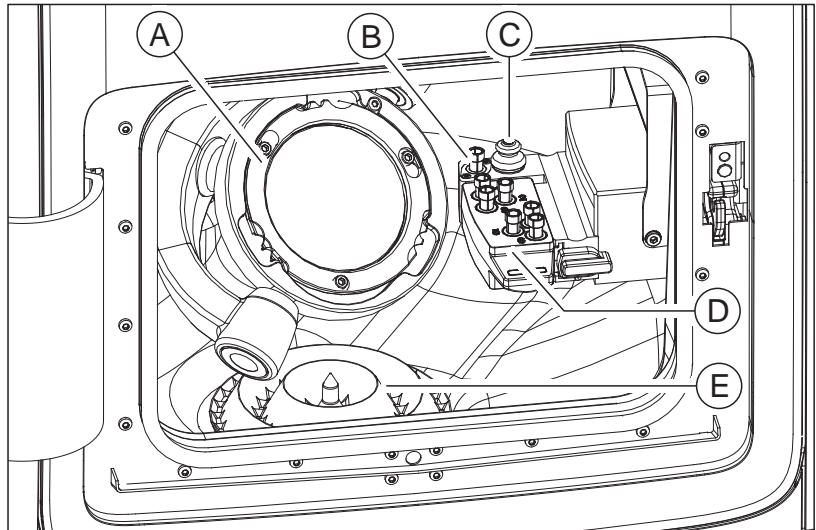

A	Workpiece holder	D	Tool magazine
B	Dummy tool	E	Processing chamber screen
C	Tool sensor		



## 2.4.2 Standard accessories

- Power supply cable
- Filter regulator including screws
- Compressed air pipe, 3m
- Compressed air pipe opaque blue, 0.75m
- Compressed air quick-connect coupling (NW7.2 and NW5)
- Suction bend DN 40 for suction
- Suction hose mandrel suction
- Suction bellow (2 pieces per packet)
- Coolant tank assembly
- Screen insert for processing chamber
- Screen insert for plastics processing
- Maintenance kit for the HF-mandrel
- Torque wrench workpiece clamping (round/multi-block holder)
- Torque wrench chuck
- Clamping ring workpiece clamping (round/multi-block holder)
- Block holder 6x including positions for + 45/90°
- Starter set tools (Bur ZrO<sub>2</sub> 2.5/1.0/0.5mm; Diamond 2.2/1.4/1.2; PMMA 2.5/1.0/0.5)
- Tool magazine (2x)
- Color scheme kit for change magazine
- Sponge for door insert (2x)
- Foam insert accessories tray
- Auxiliary tool for removing tools from the tool magazine
- inLab CAM Software DVD including license voucher
- License stick
- Crossed LAN cable
- Technical Documents

### Optional accessories

- inLab 4 PC
- Monitor
- 230 V suction device
- 120 V suction device
- inLab software DVD including inLab software license voucher
- LAN switch including LAN cable (2 m)

Type designation	inLab MC X5
Rated line voltage	AC 100 V ... 240 V
Rated power frequency	50/60 Hz
Nominal current	2.0 A
Nominal power output	200 VA
Permissible line voltage fluctuations	±10% of nominal voltage
Compressed air connection	At least 7.0 bar / 0.7 MPa / 102 psi upstream of filter regulator input Filter regulator setting 6.5 - 7.0 bar
Compressed air consumption	At least 50 l/min (1.8 cfm) Briefly up to 100 l/min (3.6 cfm) Recommended for dry operations: At least 80 l/min (2.8 cfm)
Type of protection against electric shock	Class I device
Degree of protection against ingress of water	Usual device (without protection against ingress of water), IP 20
Overvoltage category	II
Shock stress	1J (IK06) on door glass, 5J (IK08) on remaining device The impact strength on the door glass was tested with a pendulum blow test from a vertical falling height of 400 mm.
Ambient conditions	For indoor use Pollution degree 2 Air pressure: 700 hPa – 1060 hPa Operating height: ≤3000 m above sea level
Temperature range	+5°C up to +40°C (+41°F - 104°F)
Humidity range	80% rel. up to 31°C (88°F) decreasing to 50% rel. up to 40°C (104°F)
Operating mode	Continuous operation
Dimensions W x H x D	
in mm	629 x 795 x 575
in inches	24 ¾ x 31 ⅝ x 22 ⅝
Approx. weight	87 kg (191.8 lbs)

## 3 Safety information

### 3.1 Basic safety information

#### 3.1.1 Prerequisites

##### NOTE

###### Important information on building installation

The building installation must be performed by a qualified expert in compliance with the national regulations. DIN VDE 0100-710 applies in Germany.

##### NOTE

###### Restrictions regarding installation site

The system is not intended for operation in areas subject to explosion hazards.

##### NOTE

###### Do not damage the unit!

The unit can be damaged if opened improperly.  
It is expressly prohibited to open the unit with tools!

#### 3.1.2 Maintenance and repair

As manufacturers of dental instruments and laboratory equipment, we can assume responsibility for the safety properties of the unit only if the following points are observed:

- The maintenance and repair of this unit may be performed only by Dentsply Sirona or by agencies authorized by Dentsply Sirona.
- Components which have failed and influence the safety of the unit must be replaced with original (OEM) spare parts.

Please request a certificate whenever you have such work performed. It should include:

- The type and scope of work.
- Any changes made in the rated parameters or working range.
- Date, name of company and signature.

#### 3.1.3 Modifications to the product

Modifications to this product which may affect the safety of the operator, patients or third parties are prohibited by law!

### 3.1.4 Accessories

In order to ensure product safety, this device may be operated only with original Dentsply Sirona accessories or third-party accessories expressly approved by Dentsply Sirona. In particular, only the power cable also supplied or the corresponding original spare part may be used with the unit. The user is responsible for any damage resulting from the use of non-approved accessories.

### 3.1.5 In case of damage

In case of noticeable malfunctions or damage, stop using the instrument immediately and notify your authorized dealer or the manufacturer.

## 3.2 Electromagnetic compatibility

### 3.2.1 Electromagnetic emission

The **UNIT** is intended for operation in the electromagnetic environment specified below.

The customer or user of the **UNIT** should make sure that it is used in such an environment.

Emission measurement	Conformity	Electromagnetic environment - guidelines
RF emissions according to <b>CISPR 11</b>	Group 1	The <b>UNIT</b> uses RF energy only for its internal function. Therefore, its RF emissions are very low and are not likely to cause any interference in nearby electronic equipment.
RF emissions according to <b>CISPR 11</b>	Class B	The <b>UNIT</b> is intended for use in all facilities, including residential areas and in any facilities connected directly to a public power supply providing electricity to buildings used for residential purposes.
Harmonics according to <b>IEC 61000-3-2</b>	Class A	
Voltage fluctuations / flicker according to <b>IEC 61000-3-3</b>	coincides	

### 3.2.2 Interference immunity

The **UNIT** is intended for operation in the electromagnetic environment specified below.

The customer or user of the **UNIT** should make sure that it is used in such an environment.

Interference immunity tests	DIN EN 61326-1 Test level	Compliance level	Electromagnetic environment – guidelines
Electrostatic discharge (ESD) according to IEC 61000-4-2	± 6 kV contact ± 8 kV air	± 6 kV contact ± 8 kV air	Floors should be wood, concrete, or ceramic tile. If floors are covered with synthetic material, the relative humidity should be at least 30%.
Electrical fast transient/burst according to IEC 61000-4-4	± 1 kV for input and output lines ± 2 kV for power supply lines	± 1 kV for input and output lines ± 2 kV for power supply lines	The quality of the line power supply should be that of a typical commercial or hospital environment.
Surge voltages according to IEC 61000-4-5	± 1 kV differential mode voltage ± 2 kV common mode voltage	± 1 kV differential mode voltage ± 2 kV common mode voltage	The quality of the line power supply should be that of a typical commercial or hospital environment.
Voltage dips, short interruptions and variations of the power supply according to IEC 61000-4-11	<5% $U_T$ for ½ period (>95% dip of $U_T$ ) 40% $U_T$ for 5 periods (60% dip of $U_T$ ) 70% $U_T$ for 25 periods (30% dip of $U_T$ ) <5% $U_T$ for 5sec. (>95% dip of $U_T$ )	<5% $U_T$ for ½ period (>95% dip of $U_T$ ) 40% $U_T$ for 5 periods (60% dip of $U_T$ ) 70% $U_T$ for 25 periods (30% dip of $U_T$ ) <5% $U_T$ for 5sec. (>95% dip of $U_T$ )	The quality of the line power supply should be that of a typical commercial or hospital environment. Continued operation of the <b>UNIT</b> is possible following interruptions of the power supply, since the <b>UNIT</b> is powered by an uninterruptible power supply backed up by a storage battery.
Magnetic field of power frequencies (50/60 Hz) according to IEC 61000-4-8	3 A/m	3 A/m	Power frequency magnetic fields should be at levels characteristic of a typical location in a typical commercial or hospital environment.
Note: $U_T$ is the AC supply voltage prior to application of the test level.			
			Portable and mobile radio equipment must not be used within the recommended working clearance from the <b>UNIT</b> and its cables, which is calculated based on the equation suitable for the relevant transmission frequency. Recommended working clearance:

Interference immunity tests	DIN EN 61326-1 Test level	Compliance level	Electromagnetic environment – guidelines
Conducted RF interference <b>IEC 61000-4-6</b>	3 V <sub>eff</sub> 150 kHz to 80 MHz	3 V <sub>eff</sub>	$d = [1.2] \sqrt{P}$
Radiated RF interference <b>IEC 61000-4-3</b>	3 V/m 80 MHz to 800 MHz 3 V/m 800 MHz to 2.5 GHz	3 V/m  3 V/m	$d = [1.2] \sqrt{P}$ at 80 MHz to 800 MHz $d = [2.3] \sqrt{P}$ at 800 MHz to 2.5 MHz where P is the nominal transmitter output in watts (W) specified by the transmitter manufacturer and d is the recommended working clearance in meters (m). Field strengths from fixed RF transmitters, as determined by an electromagnetic site survey <sup>1</sup> should be less than the compliance level <sup>2</sup> in each frequency range. Interference is possible in the vicinity of equipment bearing the following  graphic symbol.

**Remark 1**

The higher frequency range applies at 80 MHz and 800 MHz.

**Remark 2**

These guidelines may not be applicable in all cases. The propagation of electromagnetic waves is influenced by their absorption and reflection by buildings, objects and persons.

- Field strengths from fixed transmitters, such as base stations for radio (cellular/cordless) telephones and land mobile radios, amateur radio, AM/FM radio and TV broadcasts, cannot be predicted theoretically with accuracy. An investigation of the location is recommended to determine the electromagnetic environment resulting from stationary RF transmitters. If the measured field strength in the location in which the **UNIT** is used exceeds the applicable RF compliance level specified above, the **UNIT** should be observed to verify normal operation. If unusual performance characteristics are observed, it may be necessary to take additional measures such as reorientation or repositioning of the **UNIT**.
- Over the frequency range 150kHz to 80 MHz, field strengths should be less than 3 V/m.

### 3.2.3 Working clearances

**Recommended working clearances between portable and mobile RF communication devices and the UNIT**

The **UNIT** is intended for operation in an electromagnetic environment, where radiated RF interference is checked. The customer or the user of the **UNIT** can help prevent electromagnetic interference by duly observing the minimum distances between portable and/or mobile RF communication devices (transmitters) and the **UNIT**. These values may vary according to the output power of the relevant communication device as specified below.

Rated maximum output power of transmitter [W]	Working clearance according to transmission frequency [m]		
	150 kHz to 80 MHz	80 MHz to 800 MHz	800 MHz to 2.5 GHz
	$d = [1.2] \sqrt{P}$	$d = [1.2] \sqrt{P}$	$d = [2, 3] \sqrt{P}$
0,01	0,12	0,12	0,23
0,1	0,38	0,38	0,73
1	1,2	1,2	2,3
10	3,8	3,8	7,3
100	12	12	23

For transmitters whose maximum nominal output is not specified in the above table, the recommended working clearance  $d$  in meters (m) can be determined using the equation in the corresponding column, where  $P$  is the maximum nominal output of the transmitter in watts (W) specified by the transmitter manufacturer.

**Remark 1**

An additional factor of 10/3 is applied when calculating the recommended working clearance between transmitters in the 80 MHz to 2.3 GHz frequency range in order to reduce the probability that a mobile/portable communication device unintentionally brought into the patient area could lead to interference.

**Remark 2**

These guidelines may not be applicable in all cases. The propagation of electromagnetic waves is influenced by their absorption and reflection by buildings, objects and persons.

## 3.3 Electrostatic charge

### 3.3.1 ESD protective measures

#### ESD

#### ESD protective measures

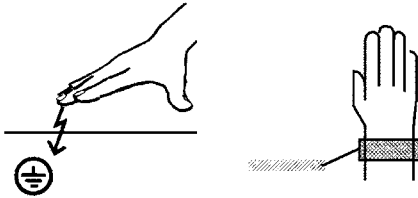

ESD stands for **E**lectro**S**tatic **D**ischarge.

ESD protective measures include:

- Procedures for preventing electrostatic charge build-up (e.g. air conditioning, air moistening, conductive floor coverings and non-synthetic clothing)
- Discharging the electrostatic charges of your own body on the frame of the UNIT, the protective ground wire or large metallic objects
- Connecting yourself to ground using a wrist band.

#### Training

We therefore recommend that all persons working with this system be instructed on the significance of this warning label. Furthermore, they also should receive training in the physics of electrostatic discharges which can occur in the practice and the destruction of electronic components which may result if such components are touched by electrostatically charged USERS.

The content of this training is explained in the Chapter "About the physics of electrostatic charges" [→ 24].

### 3.3.2 About the physics of electrostatic charges

#### What is an electrostatic charge?

An electrostatic charge is a voltage field on and in an object (e.g. a human body) which is protected against conductance to ground potential by a nonconductive layer (e.g. a shoe sole).

#### Formation of an electrostatic charge

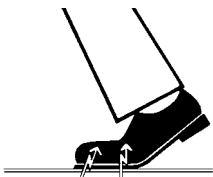

Electrostatic charges generally build up whenever two bodies are rubbed against each other, e.g. when walking (shoe soles against the floor) or driving a vehicle (tires against the street pavement).

#### Amount of charge

The amount of charge depends on several factors:

Thus the charge is higher in an environment with low air humidity than in one with high air humidity; it is also higher with synthetic materials than with natural materials (clothing, floor coverings).

Electrostatic discharge must be preceded by electrostatic charging.

The following rule of thumb can be applied to assess the transient voltages resulting from an electrostatic discharge.

An electrostatic discharge is:

- perceptible at 3,000 V or higher
- audible at 5,000 V or higher (cracking, crackling)
- visible at 10,000 V or higher (arc-over)

The transient currents resulting from these discharges have a magnitude of 10 amperes. They are not hazardous for humans because they last for only several nanoseconds.



## Background

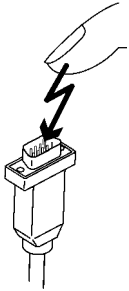

Integrated circuits (logical circuits and microprocessors) are used to implement a wide variety of functions in dental/X-ray/CAD/CAM systems.

The circuits must be miniaturized to a very high degree in order to include as many functions as possible on these chips. This leads to structure thicknesses as low as a few ten thousandths of a millimeter.

It is obvious that integrated circuits which are connected to plugs leading outside of the unit via cables are sensitive to electrostatic discharge.

Even voltages which are imperceptible to the user can cause breakdown of the structures, thus leading to a discharge current which melts the chip in the affected areas. Damage to individual integrated circuits may cause malfunction or failure of the system.

To prevent this from happening, the ESD warning label next to the plug warns of this hazard. ESD stands for **E**lectro**S**tatic **D**ischarge.

Connector pins or sockets bearing ESD warning labels must not be touched or interconnected without ESD protective measures.

### 3.4 Connecting the unit

Perform connection by following the directions given in the present operating instructions.

### 3.5 Connection of external equipment

If any equipment not approved by Sirona is connected, it must comply with the applicable standards:

- EN 60 950 for information technology equipment, and
- EN 61 010-1 for laboratory equipment.

### 3.6 Ventilation slots

Under no circumstances may the ventilation slots on the unit be covered, since otherwise the air circulation will be obstructed. This can cause the unit to overheat.

Do not spray into the ventilation slots



Do not spray liquids such as disinfectants into the ventilation slots. This may lead to malfunctions. Use wipe disinfection only in the vicinity of the ventilation slots.

### 3.7 Opening the processing chamber door

For safety reasons, the door lock is only released 15 seconds after disengaging the tool mandrel.

#### CAUTION

##### Processing chamber is lit up red

The processing chamber is lit up red in the case of any failure.

- Turn off the machine at the main switch **before** you reach out to the processing chamber. You can restart the machine once the error is eliminated.

## 4 Transportation and installation

### 4.1 Transport and unpacking

All products from Dentsply Sirona are carefully checked prior to shipment. Please perform an incoming inspection immediately after delivery.

1. Check the delivery note to ensure that the consignment is complete.
2. Check whether the product shows any visible signs of damage.

#### NOTE

##### Damage during transport

If the product was damaged during transport, please contact your carrying agent.

If return shipment is required, please use the original packaging for shipment.

#### Transportation without packaging

#### CAUTION

##### Damage to the unit or risk of injury during transport without packaging

There is a danger of the unit falling down if it is grasped by its plastic housing.

- > The unit should always be carried by three persons.
- > Do not grasp the unit by its plastic housing.
- > Always grasp the unit by the base of the unit next to its feet.

### 4.2 Disposal of packaging materials

The packaging must be disposed of in compliance with the relevant national regulations. Please observe the regulations applicable in your country.

## 4.3 Installation conditions

### 4.3.1 Installation site requirements

Make sure that the device is erected on an even, horizontal surface of approx. 640 x 600 mm (W x D). The maximum capacity should be at least 90 kg. The height of the machine is 795 mm.

Erect the machine such that the main switch can be easily accessed. Make sure that the ventilation slots on both sides of the unit remain unobstructed.

The distance between the back of the unit and the wall must at least be 2 cm.

Note the weight of 87 kg!

The unit must not be installed at sites with a high level of humidity or dust!

### 4.3.2 Suction requirements

We recommend Sirona suction (optional); REF 6385129 (230V), 6485929 (120V).

If a suction device other than that recommended by Sirona is to be used, the following requirements must be met:

- Suction power: 120 to 160 m<sup>3</sup>/h
- Dust class: M
- HEPA-microfilter, filter class: H12

### 4.3.3 Filter regulator/ compressed air supply requirements

Compressed air supply is required for operation of the device. This must meet the following minimum requirements:

- Flow rate: 50 standard liters/min
- Pressure: min. 7.0bar / 102psi
- Compressed air quality according to ISO 8573-1:2010, class 1.4.2
  - Impurities: Solid particle size < 1 µm
  - Water content: Pressure condensation point < +3 °C
  - Total oil content: < 0.1 mg/m<sup>3</sup>

The air pressure is monitored by the machine during operation. The milling program stops upon falling below the given values. The milling program can be continued once the values are correct and the error message was acknowledged.

## 4.4 Connecting the suction device

This section describes the connection of the Sirona suction. If you use a suction device from an external supplier, note the following information.

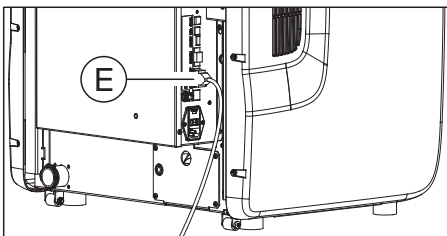
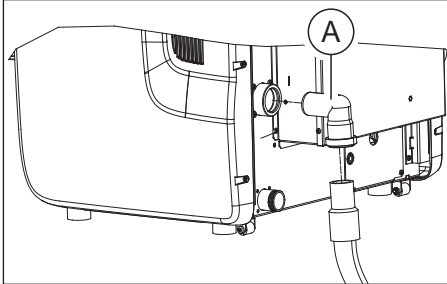

1. If you use the Sirona suction device, connect the hose supplied with the suction device to the connection (A) on the back of the unit.
2. Connect the suction device and the unit using the communication cable supplied with the suction device, so as to enable the automatic mode. To do this, connect the communication cable to the device over the interface "Communication interface for suction (E)".
3. If you have a central or another suction device, connect this to the connection (A).

### IMPORTANT

#### Follow the requirements

When using a suction device that is not approved by Sirona, follow the requirements in section "Suction requirements [-> 28]".

Ensure the correct configuration of the suction device in the machine configuration menu.

Note that the pipe to the suction device must have an inner diameter of 38 mm.

## 4.5 Connecting the coolant tank

### IMPORTANT

#### Coolant-lubricant mix

Make sure that the configuration of the coolant-lubricant mix is correct according to the material class to be processed:

- Tank contents material class sintering metal: 10 L water
- Tank contents material class PMMA/composite/grinding materials: 250ml Dentatec + 10L water
- Tank contents material class metal: 1 bottle of DentaLub (900 ml) + 10L water
- Tank contents cleaning tank: 10 L water

In order to connect the coolant system, proceed as follows:

1. Mount the filter cartridge of the tank on the filter cartridge of the tank.
2. Place the filter cartridge into the tank and lock the tank opening.

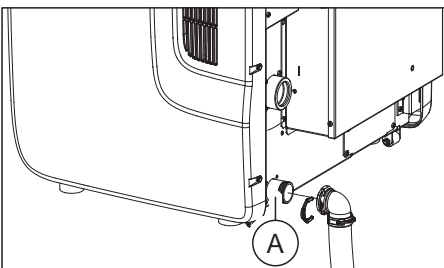
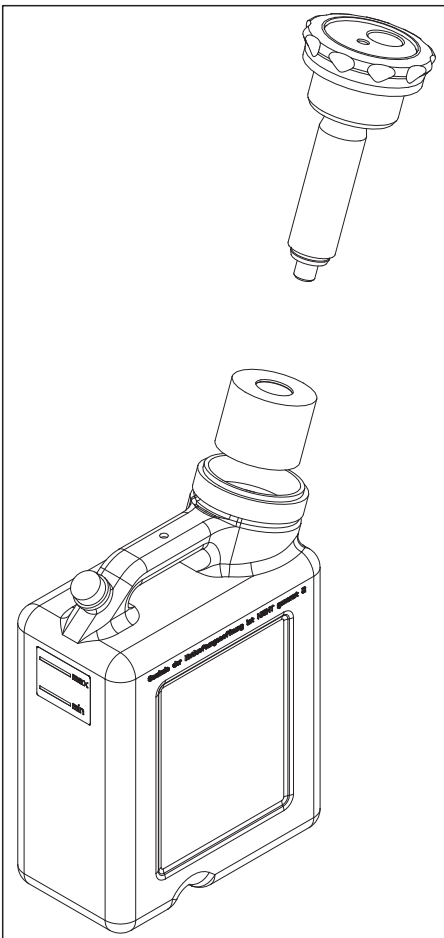

3. Connect the coolant tank to the coolant drainage connection (A) using the coolant return hose supplied with the tank as well as the accompanying angle unit.

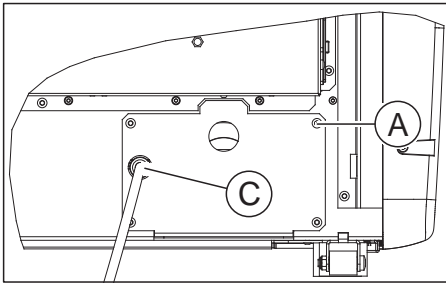

4. Connect the coolant hose to the coolant inlet connection (C) for supply of coolant to the machine.

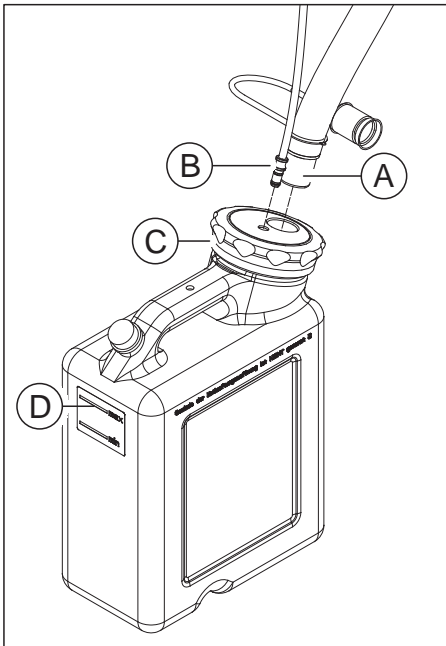

5. Connect the coolant inlet hose as well as the coolant return hose to the connections provided in the tank system.

#### NOTE

##### Risk of overflowing

Overflows may occur if the coolant return hose of the tank sags.

- Mount the tank, so as to ensure continuous inclination of the coolant return hose, particularly in the hose piece on the table surface immediately after the outlet from the back side of the machine.
- Ideally, position the tank under the machine. You may have to turn the tank or shift it to do this.

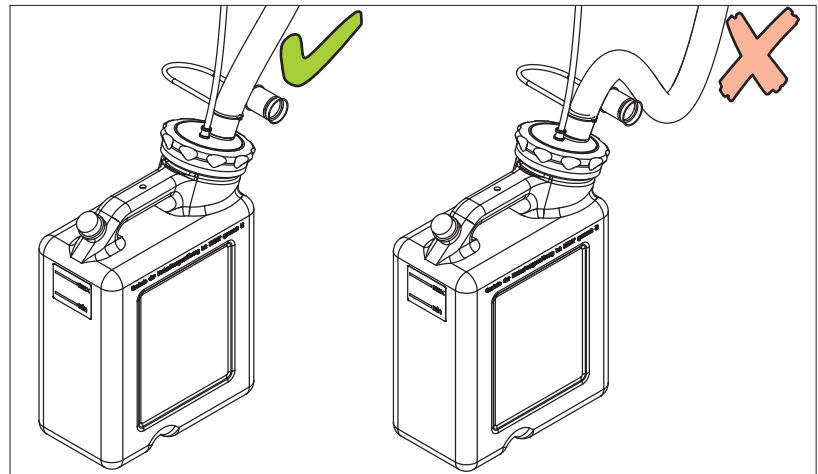

6. Install the tank underneath the machine and establish a direct hose supply for the coolant return hose without a dip. Remove the angle unit and shorten the hose if required for this. If required establish a direct connection between the tank and the machine via a hole in the work set-up area.

## 4.6 Connecting the filter regulator

### NOTE

#### Avoiding any damage to the machine

The unit is equipped with a high-frequency mandrel that has a pneumatic collet chuck and an air purge mechanism. A filter regulator that filters impurities from the compressed air and protects the machine from any damage should be interposed for supply of the required compressed air.

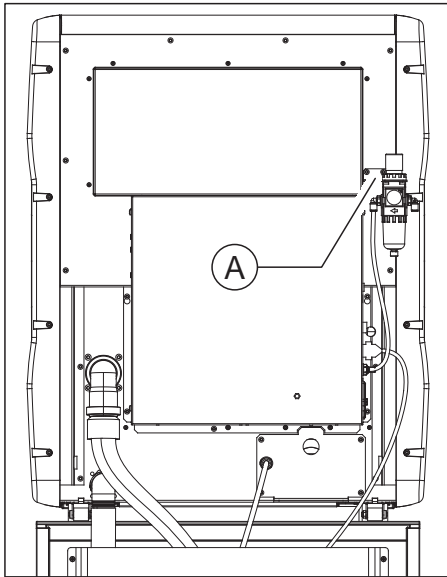

1. Screw the filter regulator firmly at the corresponding place (A) on the device using the screws provided. Alternatively, the filter regulator can be positioned for improved visibility of the print display even at an external position with corresponding conditions.

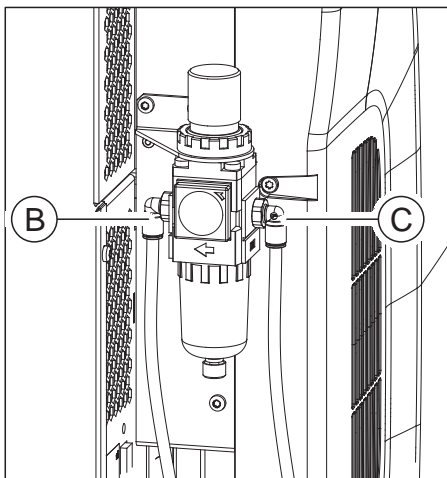

2. Connect the left compressed air outlet (B) of the filter regulator with the inlet on the device side. Use the accompanying compressed air pipe for this (blue, 0.75 m). Shorten the pipe by approx. 30 cm and connect the left output point of the filter regulator with the machine connection point.
3. Connect the right compressed air connection (C) of the filter regulator with the stationary compressed air connection at the installation site. To do this, use the compressed air pipe (3 m) as well as the provided quick-connect couplings. If you have a special compressed air connection system, contact your installer in charge.



## 4.7 Connecting the PC/interfaces

The "Ethernet (RJ45)" port is located at the rear of the unit (see Connections [→ 14]) and can be used for connecting the PC to the machine. Use a network cable to do this (LAN connection).

- > Connect the unit with the network card of your PC using the provided network cable.

### IMPORTANT

If you wish to integrate the inLab MC X5 into an existing network then please contact your responsible IT technician.

## 4.8 Repacking

- ✓ The coolant tank is empty.
  - ✓ The main switch on the back side of the unit is set to the 0 (OFF) position.
1. Disconnect the power cable and the connecting cable from the back side of the unit and stow them away.
  2. Check the unit for completeness according to the scope of supply!
  3. Pack the unit securely and use the transport locks provided for tool spindles, workpiece holders and tool magazines.

## 4.9 Storage

Store the unit in a closed and dry room at a temperature of -10°C to 50°C for a maximum period of 12 months.

## 5 Commissioning

### 5.1 Putting the inLab 4 PC into operation

Observe the following steps in order to put the unit into operation using the inLab 4-PC (optional).

#### 5.1.1 Startup prerequisites

##### 5.1.1.1 Required accessories

###### Supplied parts:

- inLab PC with power cable
- Keyboard
- Mouse
- 2x DVI VGA converters
- Power cable
- Ethernet cable for connection of the machine with the PC.

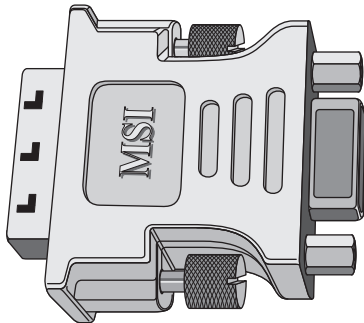
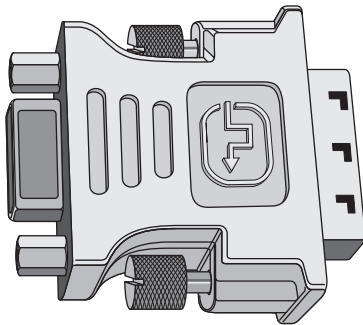

**Also required:**

- VGA/DVI monitor including VGA/DVI cable (not included in scope of supply)

**⚠ CAUTION**

**Image may not display**

Please note the required minimum monitor resolution of 1280 x 1024 at 70Hz. Please refer to the technical documentation of the monitor for the correct resolution and frame rate settings.

**Recommendation:**

- Sirona inLab system PC monitor, Order No.: 60 42 548 D3446

In order to connect a VGA monitor, screw one of the two converters onto the left DVI port as shown in the photo.

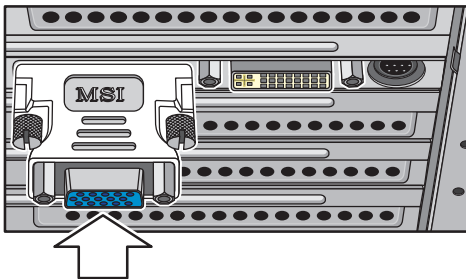

### 5.1.1.2 Making connections

#### NOTE

**Do not connect and turn on the device yet!**

First, connect the PC to the monitor, keyboard, and mouse.

Follow the instructions in this document exactly in order to successfully perform start-up of your device.

**You must install the user software prior to connecting the device to the PC.**

1. Connect the keyboard and the mouse to the PC.
2. Connect the monitor to the PC with the VGA/DVI cable.
3. Connect the Ethernet port on your device to the Ethernet port on your PC.
4. Turn on the monitor and PC power supplies.
5. Turn on the power switch on the rear panel of the PC (if present).

## 5.1.2 Safety

inLab 4-PC V 1.0.1 is equipped with Windows 7 Professional (64 bit). The Windows Firewall is activated. The software Microsoft Security Essentials is also pre-installed by default. Please activate the automatic update function in the settings of this software for optimal protection.

### CAUTION

#### **Damage to the system and data loss:**

If you exchange files and programs with other PC systems and/or operate this PC in a network (LAN or Internet), damage may be caused by software viruses.

- Activate the "Automatic Updates" function of Microsoft Security Essentials.
- Activate the "Automatic Updates" function of Windows 7.
- Run backups of all your important files at regular intervals.

### 5.1.3 Installing the software

#### NOTE

##### Initial installation without device

Perform the initial installation of the software **without** the connected device.

The software requires the 2.00 firmware version of the license stick. Update the firmware version if necessary. For additional information, refer to the "License manager" section in the user manual inLab CAM.

A inLab 4-PC V 1.0.1 hardware version V 1.0.1 or higher is required for the software.

Use the version of the license manager provided with this version to import licenses from the license certificate provided.

- ✓ The license stick firmware is available in version 2.00.
- ✓ The PC is powered up and all programs are terminated.
- 1. Insert the DVD in the DVD drive.
  - ↳ The setup program starts automatically.
- 2. If this is not the case, run the "*Setup.exe*" file in the root directory of the DVD.
  - ↳ The installation wizard opens.
- 3. Click on the "*OK*" button.
- 4. In the next dialog, click the "*Next*" button.
  - ↳ The license agreement is shown.
- 5. Read through the license agreement carefully.
- 6. If you accept the license agreement, then activate the "*I accept the terms in the license agreement*" option button and click the "*Next*" button.
- 7. In the next dialog, click the "*Next*" button.
- 8. In the next dialog, click the "*Install*" button.
  - ↳ The program continues the installation routine. This may take several minutes.
- 9. Click the "*Finish*" button once installation is complete.
  - ↳ The software is installed.

## 5.2 Putting the unit into operation

### 5.2.1 Connecting the unit to the power supply

#### NOTE

##### Grounded power outlet

The unit must be connected to a grounded power outlet.

- > Connect the unit to the power supply using the supplied power cable.

### 5.2.2 Checking the compressed air

1. Check whether 7 bar / 102psi of compressed air is displayed on the filter regulator display.
2. If this is not the case check your compressed air system and/or contact your responsible compressed air installer.

### 5.2.3 Functional elements

#### 5.2.3.1 Button assignment

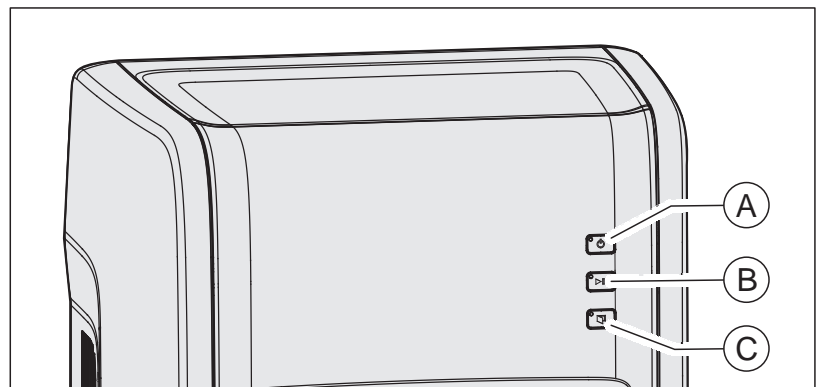

These operating instructions describe how to operate the unit by executing and confirming commands via your PC. You can also directly actuate the commands such as "Start", "Stop" or "Ok" by pressing the buttons on the device.



For the commands, refer to the table below.

#### Button assignment

Push button	Function
A	ON/OFF button
B	Start/ stop/ resume process
C	Open door

### 5.2.3.2 Color status of the buttons and the processing chamber

The LED elements of the buttons A, B, C and the illumination of the processing chamber indicate the operating status of the device.

Push button			Illumination of the processing chamber	Operating status
				
A	B	C		
Blue	OFF	OFF	OFF	Main switch ON / device is in the standby mode
Yellow	OFF	OFF	OFF	ON/OFF button pressed; device is in the booting process
Yellow	OFF	Green	OFF	Machine boots, door closed (but can be opened)
Green	OFF	Green	Yellow	Machine ready for operation, no reference known and B-axis not on Ini, door closed
Green	OFF	Yellow	Yellow	Machine ready for operation, no reference known and B-axis not on Ini, door opened
Green	OFF	Green	White	Machine ready for operation, door closed
Green	OFF	Yellow	White	Machine ready for operation, door opened
Green	Green flashing	Green	White	Processing ready to start, insert block, door closed
Green	Green	OFF	White	Processing is in progress
Green	OFF	Green	Green	Processing concluded in a controlled manner
Green	Flashing yellow	Green	Yellow	Process interrupted with Stop
Green	Red flashing	Green	Red	Process interrupted because of error
Flashing yellow	OFF	OFF	OFF	Machine switch off
Red	OFF	OFF	OFF	Internal error, restart necessary
Green	Red	Green	Red	Error with tool change*, door closed
Green	Red	Yellow	Red	Error with tool change*, door opened

\* This status occurs if there is an error with the tool change which the machine is unable to resolve itself. Unlike with a "normal" error you can acknowledge the message on the machine. The acknowledgment



opens the collet chuck and this should therefore be executed at the machine because you can then grab the tool.

### 5.2.4 Removing the transport safety device and putting the processing chamber into operation

The machine is equipped with a transport safety device that must be removed during commissioning. To do this, proceed as follows:

1. Switch the unit on at the main switch.
2. Start the machine by pressing the On/Off button.
3. Open the door using the door release button.
4. Take out the transport safety device.
5. Insert the supplied sponge **C** into the drain groove **D** of the door.

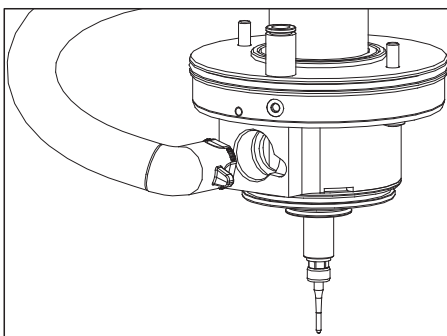
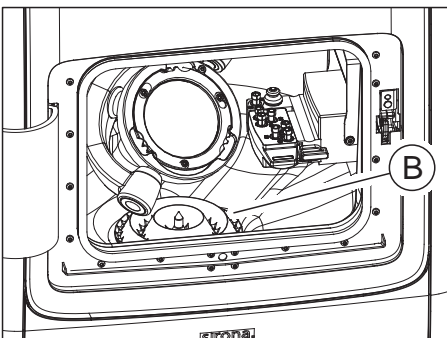
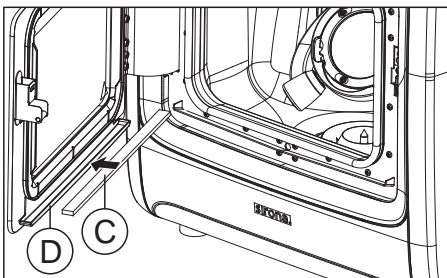
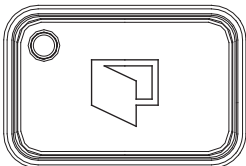
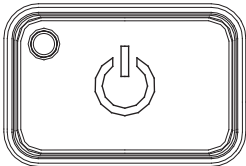

6. Place the supplied screen insert **B** in the lower drain.
7. Connect the suction hose of the mandrel suction to the mandrel.

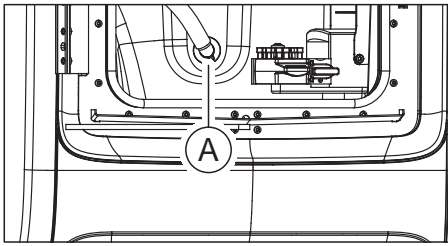

8. Connect the suction hose of the mandrel suction **A** in the processing chamber.

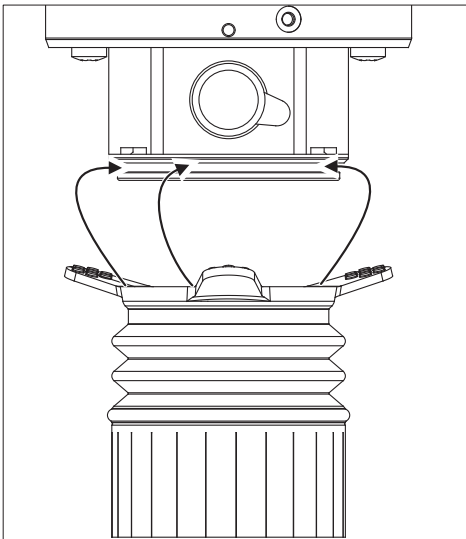

9. Mount the suction bellows on the mandrel. To do this, first allow the rear part of the bellows to engage into the groove of the mandrel. Then pull the suction bellows over the mandrel by holding at the two front rubber handles so that the bellows are engaged on all sides.

### 5.2.5 Filling the coolant tank (for material classes PMMA/wax, composite and grinding materials)

#### IMPORTANT

##### Note material class

This section applies for the use of the coolant tank when processing the material class PMMA/wax (material class index **red**), composite (material class index **blue**) and grinding materials (material class index **white**).

When processing materials from material classes sintering metal (**gray**) and metal (**green**), observe the specific instructions for filling the coolant tank in then specific sections on processing such materials.

- ✓ The unit is switched on.
- ✓ No machining process is running.

#### NOTE

##### Risk of damage to the hoses!

Pulling at the inlet and outlet hoses may damage them.

- Always draw off the hoses at the pipe piece.

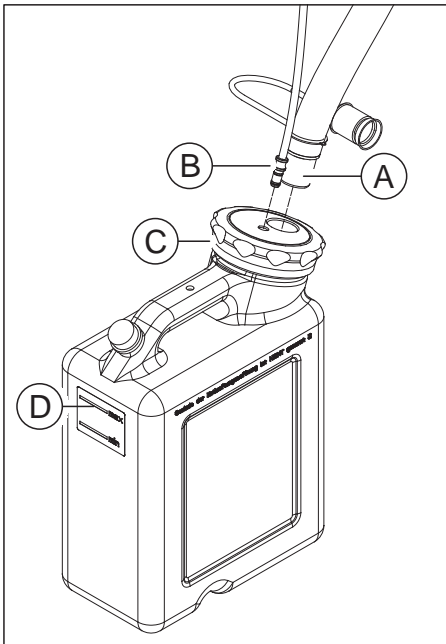

1. Draw off the machine-sided coolant drainage hose (A) with the large diameter as well as the thin coolant supply hose (B) from the tank.

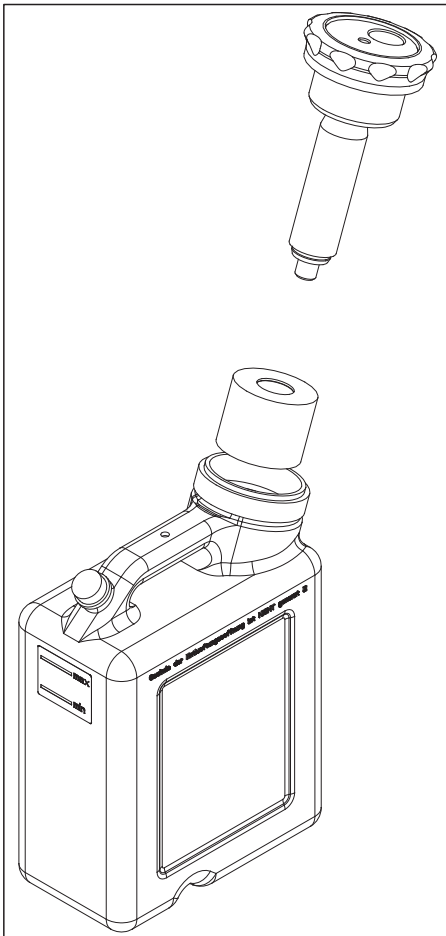

2. Open the tank lid clip (C) and pull the filter system out.

#### NOTE

##### Foaming not permissible!

If any cleaning agents are used, this will create foam, which is not permitted.

- > Do not use any cleaning agents.

3. Fill the tank with water up to the mark (max, D) (approx. 10 liters).

#### NOTE

##### Damage to surfaces!

When undiluted, DENTATEC grinding additive etches plastic surfaces and can cause discoloration.

- > Do not place DENTATEC on the unit.
- > Do not spill DENTATEC.

4. Add approx. 250 ml DENTATEC to the tank. The mixture ratio is: 1 l water to 0.025 l DENTATEC.
5. Place the filter system in the tank.
6. Lock the tank with the tank lid clip.
7. Reconnect the coolant drainage hose (A) with the large diameter as well as the thin coolant supply hose (B) to the tank system.

## 5.2.6 Switching the unit ON and OFF

### NOTE

#### Do not put the unit into operation at low temperatures!

If you move the unit to the operating site from a cold environment, condensation may form and result in a short circuit.

Within the machine, grease depots are included for lubricating components that can cause error messages at low temperatures.

- ✓ Install the unit at room temperature.
- Wait until the unit has reached room temperature and is absolutely dry (for at least one hour)
- ↪ The unit is dry and can be put into operation.

### NOTE

#### Do not adjust the line voltage

The unit automatically adjusts to the line voltage.

### Switching the unit on

- ✓ The unit is connected to the power supply.
- 1. The main switch on the left rear side of the unit is set to position I (ON).
  - ↪ It takes 10-15 seconds for the front LED to light up green.
- 2. Press the ON/OFF button on the front panel.
- ↪ The unit switches itself on and the machining chamber is illuminated white or yellow (white only, if the workpiece holder is level with the clamp of the support arm).

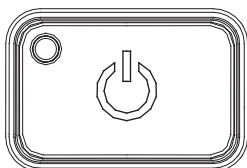
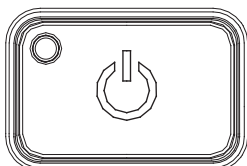

### Switching the unit off

- ✓ The unit has finished the machining operation.
- Briefly press the ON/OFF button on the front panel.
- ↪ When you let go of the button, the unit switches off.

## 5.2.7 Installing and configuring the unit

### 5.2.7.1 Installing the unit

You must connect the unit to the PC before putting it into operation. This is described in the chapter "Connecting the PC/interfaces [-> 33]".

#### IMPORTANT

The inLab MC X5 can be operated with both a static as well as an automatically assigned IP address.

From the factory the inLab MC X5 is always configured with a static IP address. The standard IP address is as follows: 192.168.230.xy. The digits x and y are made up from the last two digits of the unit serial number. These can be found on the label on the rear of the device. If the serial number ends in "00" then the xy value is always "100".

The MAC address for the network card can be found on the machine's configuration menu.

To change the IP configuration always establish a direct connection with static IP address to your PC's network card. The network address for the inLab 4-PC used is 192.168.230.101. The subnet mask is 255.255.255.0.

#### 5.2.7.1.1 Automatic unit search

- ✓ The unit is connected to the PC using a direct connection via Ethernet cable.
- ✓ The unit is switched on.
- 1. Start the "inLab CAM" software.
- 2. Click on the "Machine and Instrument tray Management" button in the system menu.
- 3. Click on the "Scan for New Devices" button.
  - ↳ All units connected to the PC are recognized.
- 4. Enter a name for the new unit.



#### 5.2.7.1.2 Manual unit search



- ✓ The unit is connected to the PC using a direct connection via Ethernet cable.
- ✓ The unit is switched on.
- 1. Start the *"inLab CAM"* software.
- 2. Click on the *"Machine and Instrument tray Management"* button in the system menu.
- 3. Click on the *"Add Device (Manual)"* button.
- 4. Select *"Network"*.
- 5. Enter the network address.
- 6. Click on the *"Ok"* button.
  - ↳ The software attempts to contact the device.

If the connection fails, check the connection. If necessary, ask a qualified technician.

#### 5.2.7.1.3 Updating devices

With the *"Refresh Devices"* button you can

- display the status; e.g. check whether a machine has in the meantime finished producing, or
- Check the current availability of a device.

#### 5.2.7.1.4 Remove the unit

If you no longer require a unit (e.g. a unit is replaced), you can remove it.



- ✓ The unit is not in operation.
- 1. Click on the *"Machine and Instrument tray Management"* button in the system menu.
- 2. Click on the unit that you wish to uninstall.
- 3. Click on the *"Delete Device"* button.
  - ↳ You will be asked if you would like to remove the unit.
- 4. Click on the *"YES"* button.
  - ↳ The device is removed.

#### 5.2.7.2 Configuring the device

In the *"Machine and Instrument tray Management"* software *"inLab CAM"* area you can make subsequent amendments to the various settings for your unit.

1. Click the *"Configuration"* button in the system menu.
2. Click on the *"Machine and Instrument tray Management"* button.
3. Click on the unit that you wish to configure.

### 5.2.7.2.1 Editing inLab MC X5 device settings

Via menu item "*inLab MC X5*" / unit name you can make or view the following changes retroactively:

- Name/ description
- Connection settings
  - Automatic IP setting
  - Manual IP settings
  - Display of the MAC address
- Suction
  - Sirona suction
  - External suction
- Use spindle touch
  - Spindle run time (h): Shows how long the tool spindle has been in use
  - Spindle ID: Shows the type of tool spindle. This is particularly important for selecting a suitable replacement collect chuck (blue: type 1; green: type 2)
- External tank
- Firmware download

#### 5.2.7.2.1.1 Device settings

##### Manual IP settings

The IP address can be changed in order to integrate the machine into existing networks. To do this, proceed as follows:

1. Establish a direct connection with the inLab 4 PC (see Installing the unit [→ 45]).
2. If you want to change the static IP address, click "*Edit Device Settings*".
3. Enter the network settings in accordance with your local network configuration.
4. Confirm the new network settings using "*Ok*" or press "*Cancel*" in order not to save the changed settings.
5. Disconnect the Ethernet connection with the PC and connect the machine to the network socket in your local network (see Connecting the PC/interfaces [→ 33]).

##### Automatic IP settings

There is an option for integrating the machine into an existing network with DHCP server in such a way that the IP address is received by the DHCP server automatically. To do this, proceed as follows:

1. Establish a direct connection with the inLab 4 PC (see Installing the unit [→ 45]).
2. If you want to change the IP address to automatic addressing, click "*Edit Device Settings*".
3. Now click "*Auto IP settings*".

#### **IMPORTANT**

Ensure that the network in which you are integrating the machine has an active DHCP server for the allocation of IP addresses.

4. Confirm the new network settings using "Ok" or press "Cancel" in order not to save the changed settings.
5. If you have changed the setting to "Automatic" you must now disconnect the Ethernet connection to the PC and connect the machine to the network socket in your local network.
6. If you wish to change the settings back again then change over to "Manual IP settings".

#### IMPORTANT

If the machine is in "Auto IP settings" mode and does not detect any active DHCP server, the IP is automatically reset to 192.168.230.1. You can then add and manage the machine again using a direct connection to a PC via the "Add Device (Manual)" function.

#### Suction

You can define the type of suction used using the "Suction" setting.

- "Sirona": You are using the optional suction available for inLab MC X5. Select this option and connect the suction to the machine (including interface cable). The communication between inLab MC X5 for starting and stopping the suction etc. is then automatic.
- "Other": You are using a different, external suction. Select this option and ensure that the requirements for external suction (see Suction requirements [-> 28]) are fulfilled. The suction must then be switched on and off manually for each process.

#### Use Spindle Touch

Using the "Use Spindle Touch" setting, you can choose whether the selected block size should be checked, and if the exact position of the block in the machine should be determined, for the inLab MC X5 during grinding and milling processes.

#### IMPORTANT

Please note that in cases where this option ("Use Spindle Touch") is not activated, grinding processing of the meso structure blocks is not possible.

#### External tank

Select this option if you have connected the coolant tank in order to be able to start wet processes.

#### IMPORTANT

Note that if this option is not selected then no wet processes (e.g. for processing glass ceramics) can be started. In this case, it is possible to process the material classes PEEK, PMMA and composite and this takes place as a dry process.

#### Firmware download

Each device (inLab MC XL or inLab MC X5) requires a firmware version which is compatible with the respective version of the software inLab CAM.

You start the download of the appropriate firmware for - via this button.



### IMPORTANT

If a unit does not have the correct firmware version, this is in fact detected by the software, yet it cannot be used for production. It is indicated as "invalid firmware" both in the device management and in the production phase.

#### 5.2.7.2.1.2 Change instrument magazine (only inLab MC X5)

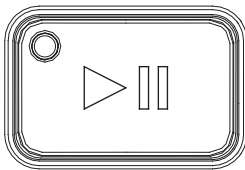

- ✓ The magazine to be used is already created in the software.

  1. Click on "*Change instrument tray*" to change a magazine.
  2. Select the instrument magazine you want to use in the software selection list through the selection box.
  3. Click on "*Confirm and Exit*".
  4. Physically replace the instrument magazine in the machine.
  5. Then confirm the magazine change by pressing the on/off button on the machine.

### IMPORTANT

The cover of the instrument magazine stays open in the machine for as long as they are in the instrument change dialog. After changing the magazine in the machine, ensure that the lock of the magazine in the machine is shut properly. The cover of the instrument magazine closes again when you exit the change dialog in the software.

### 5.2.7.2.1.3 Service menu (only inLab MC X5)



You can do the following in the service menu:

- Spindle maintenance
- Moving to the cleaning position
- Switching the water pump on/off
- Switching the suction on/off
- Opening the chuck

#### Spindle maintenance

1. Click on the start button to start the spindle maintenance.
2. Then simply proceed as prompted by the software.
3. Read also which steps are to be performed in the inLab MC X5 operating instructions under the section "Tool spindle maintenance".

#### IMPORTANT

If the clamped instrument cannot be removed from the machine automatically, you can replace it manually through "*Spindle Maintenance*". To do this click on the start button for the spindle maintenance and follow the on-screen instructions.

#### Moving to the cleaning position

- > Click on the start button to move to the cleaning position.
  - ↳ The machine moves to the cleaning position.

#### Starting the cleaning process

- > Click on the start button to start the automatic cleaning cycle.
  - ↳ The machine moves for cleaning essential areas with the spindle using the coolant.

#### Switching the water pump on/off

1. Click on the start button to turn on the water pump.
  - ↳ The water pump is switched on.
2. Click on the pause button to turn off the water pump.
  - ↳ The water pump is switched off.

#### Opening the chuck

- > Click on "*Open chuck*" to be able to manually take instruments out of the chuck.

#### IMPORTANT

Then ensure that the chuck is properly tightened and the dummy tool is placed in its position.

### Switching the suction on/off

1. Click on the start button to turn on the suction device.  
↳ The suction is switched on.
2. Click on the pause button to turn off the suction device.  
↳ The suction is switched off.

## 6 Operation

### 6.1 Referencing run

#### NOTE

##### Observe the Operator's Manual

Please also observe the information in the Operator's Manual for inLab CAM SW software.

The referencing run is used for the function check of the detection system and the position check of moving parts in the processing chamber. The referencing run takes place automatically via the firmware. The complete referencing run always takes place following switch-on of the machine immediately before starting the first job. The shortened referencing run takes place before every new job.



#### NOTE

##### Ensuring the workpiece holder position

The workpiece holder possesses two moving axes. In the manual adjustment of the position, it must be ensured before every referencing run that the workpiece holder is in the horizontal position, i.e. level with the clamp of the support arm. The machining chamber lighting then switches to white.



## 6.2 Machining processes

Before every process, make sure that all necessary connections are correctly coupled and check the function of the suction device, air pressure provision and water supply.

### IMPORTANT

Note the processing instructions of the respective material manufacturer for all manufacturing processes.

### NOTE

Check the processed restorations after completion of the process and finishing (e.g. sintering, stain & glaze, polishing) for any defects. Note the requirements and instructions of the respective material manufacturer for this.

### 6.2.1 Process types

#### CAUTION

##### **Risk of injury through sharp-edged restorations and material residues**

There is risk of injury through sharp-edged restorations as well as sharp-edged material residues.

- > Remove the restored objects and material residues carefully after the processing.
- > Pay attention to the sharp-edged material residues while cleaning the processing chamber.

Different process types are available for machining. These differ in the type of the materials to be processed, the tools to be used and the corresponding fixture in the unit.





#### CAUTION

##### **Risk of injury through cutting and grinding tools**

There is risk of cuts through sharp edges of accessible parts and the use of rotating cutting and grinding tools that are sharp and/or pointed.

### 6.2.1.1 Grinding















The grinding process is done in a wet condition. Check the functioning and tightness of the connections for the coolant tank as well as the filling level regularly using the *min* / *max* marking. Use the following tools for grinding.







Tool	Image	Ring color	REF
Diamond 1.4		White	6478015
Diamond 1.2		White	6478023
Diamond 2.2		White	6478007
Diamond 0.6		White	6542232

Note the processing instructions of the respective material manufacturer.

### 6.2.1.2 Milling

The milling process is done in a wet or dry condition. Regularly check whether the connections of the coolant tank and the suction device are functioning properly and are leak-proof. Depending on the respective materials, use the tools listed in the table for milling. Note also the notes in the tool change dialog box in the inLab CAM software.

Tool	Image	Ring color	REF
Bur 0.5 PMMA		Red	6478114
Bur 1.0 PMMA		Red	6478106
Bur 2.5 PMMA		Red	6478098
Bur 0.5 ZrO2		Yellow	6478056
Bur 1.0 ZrO2		Yellow	6478049
Bur 2.5 ZrO2		Yellow	6478031
Bur 0.5 ZrO2 DC		Yellow	6572957
Bur 1.0 ZrO2 DC		Yellow	6572940
Bur 2.5 ZrO2 DC		Yellow	6572932
Bur 0.5 Composite (for software version inLab CAM SW ≤ 15.2 only)		Blue	6478171
Bur 0.5 Composite (coated) (for software version inLab CAM SW ≥ 16.0 only)		Blue	6559368
Bur 1.0 Composite (for software version inLab CAM SW ≤ 4.3.1 only)		Blue	6478163 (no longer available)
Bur 2.5 Composite (for software version inLab CAM SW ≤ 4.3.1 only)		Blue	6478155 (no longer available)
Bur 1.0 Composite (coated) (for software version inLab CAM SW ≥ 15.0 only)		Blue	6551696

Tool	Image	Ring color	REF
Bur 2.5 Composite (coated) (for software version inLab CAM SW $\geq$ 15.0 only)		Blue	6551688
Bur 0.5 sintering metal		Gray	6478080
Bur 1.0 sintering metal		Gray	6478072
Bur 2.5 sintering metal		Gray	6478064
Bur 1.0 metal		Green	6606292
Bur 2.0 metal		Green	6606243

Make sure that the correct screen insert is placed in the processing chamber before starting with the milling process.

Note the processing instructions of the respective material manufacturer.

### 6.2.1.3 Wet processing

#### IMPORTANT

Prior to wet processing, make sure that the tank is filled and connected to the machine, the filter is inserted and is ready for operation. Regularly check whether all connections are leakproof.

### 6.2.1.4 Dry processing

Prior to dry processing, make sure that the Sirona suction device or another one is connected to the suction connection of the machine according to the requirements. Once the Sirona suction device is connected, switch it to the automatic mode. The control and monitoring of the suction takes place automatically via the device now.



## 6.2.2 Tool magazine

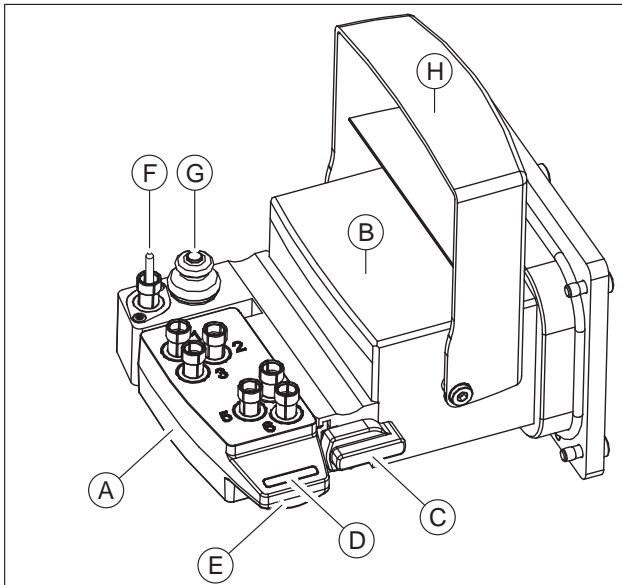

Tool magazine locked (C)

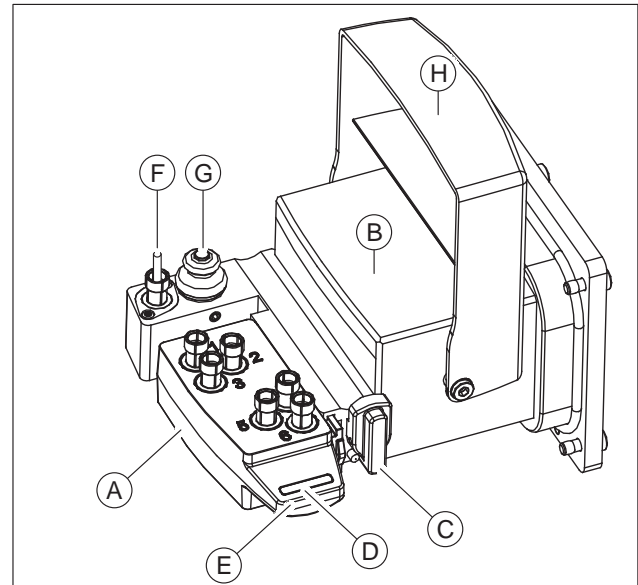

Tool magazine unlocked (C)

A	Tool magazine
B	Tool magazine holder
C	Tool magazine lock
D	Color scheme of tool magazine
E	Tool magazine handle
F	Dummy tool
G	Button for tool length precision
H	Tool magazine cover flap

### CAUTION

#### Risk of injury while reaching out to the processing chamber

There is the risk of cut injuries and crushing through sharp tools and moving parts.

- Make sure that you do not touch the sharp tools and moving parts.

#### Taking out and inserting the tool magazine

Use the tool magazine handle (E) and the available guide rail for taking out and inserting the tool magazine. Fixing and releasing the tool magazines is done using the tool magazine lock (C).

1. To change the tool magazine in the machine click in the inLab CAM software on "Configuration".
2. Select "Devices" and click on the inLab MC X5 for which you wish to change the tool magazine.
3. Select "Change Instruments" and follow the dialog in the software.

## Managing tool magazines

A tool magazine has six user-assignable tool places which are numbered and can be individually populated via the inLab CAM software ("Configuration /Devices / inLab MC X5 / Machine and Instrument tray Management / Instrument tray database").

Several tool magazines can be created for different materials. These can be color-coded using the tool magazine color scheme (**D**) for better distinction.

## Dummy tool

The available dummy tool (**F**) is always in the device of the tool magazine holders and may not be removed. The dummy tool protects the mandrel and is automatically included during machine downtimes. For this reason, the compressed air supply to the machine may not be disconnected at any time as inclusion of the dummy tool cannot take place. The precision button (**G**) that is directly next to the dummy tool is to kept clean and it is used to check the tool length, with which the tool can also be identified.

## Tool magazine cover flap

The tool magazine cover flap (**H**) opens and closes automatically as soon as the functions of the tool and/or magazine change are enabled in the software. During the machining processes, the cover flap remains closed always.

The places of a tool magazine can be equipped with the 3 standard tools per material (see "Permitted tool combinations"). Associated tools of the same type can also be used on the other positions. In the case of a tool loss or when reaching the wear limit of a tool during the process, it is resorted to the relevant associated tool.

Likewise, a tool magazine can be equipped with different tools (e.g. 3 grinding tools and 3 milling tools of a material).

The magazine is equipped manually, outside of the machine, in accordance with the allocation positions and tools in the software. Once the tool or magazine change is enabled in the software, the cover flap of the tool magazine opens automatically. The closing after equipping also occurs automatically via the software.

## Equipping the tool magazine

In order to equip the tool magazine, proceed as follows:

### CAUTION

#### Risk of injury through sharp tools and moving parts

While equipping the tool magazine, there is the risk of cut injuries as the cutting edges of the tools are very sharp. There is also the risk of crushing through moving parts.

- > Make sure that you do not touch the sharp tools and moving parts while reaching out to the processing chamber.

1. Create a new tool magazine under "*Instrument tray database*" in the machine configuration menu in the software and assign the intended tools to the positions 1-6 in the software.















### IMPORTANT



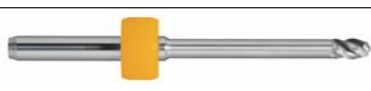



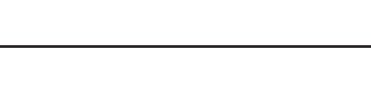

When creating a grinding tool kit, at least 3 positions should be assigned to the three different grinding tools. While creating a magazine with milling tools, at least 1 x 2.5 mm milling tool and 1 x 1.0 mm milling tool of a material type (ZrO<sub>2</sub>, PMMA or sintering metal) must be equipped.

2. Open the door of the machine by pressing the Unlock door button.
3. Remove the magazine out of the tool magazine holder by turning the lock clockwise by 45°.
4. Use the handle to pull the magazine out of the guide. Each one the tool places is equipped with a cushioning bowl, is inserted becomes in that the corresponding tool with the tip downward into the planned place.
5. Now place the tool with the processing side down until the stop ring.
6. The existing tools are removed by simply pulling it out by hand using the removal tool also supplied.



### 6.2.2.1 Available tools

Tool	Image	Ring color	REF
Diamond 1.4		White	6478015
Diamond 1.2		White	6478023
Diamond 2.2		White	6478007
Diamond 0.6		White	6542232
Bur 0.5 PMMA		Red	6478114
Bur 1.0 PMMA		Red	6478106
Bur 2.5 PMMA		Red	6478098
Bur 0.5 ZrO2		Yellow	6478056
Bur 1.0 ZrO2		Yellow	6478049
Bur 2.5 ZrO2		Yellow	6478031
Bur 0.5 ZrO2 DC		Yellow	6572957
Bur 1.0 ZrO2 DC		Yellow	6572940
Bur 2.5 ZrO2 DC		Yellow	6572932
Bur 0.5 Composite (for software version inLab CAM SW ≤ 15.2 only)		Blue	6478171
Bur 0.5 Composite (coated) (for software version inLab CAM SW ≥ 16.0 only)		Blue	6559368
Bur 1.0 Composite (for software version inLab CAM SW ≤ 4.3.1 only)		Blue	6478163 (no longer available)

Tool	Image	Ring color	REF
Bur 2.5 Composite (for software version inLab CAM SW ≤ 4.3.1 only)		Blue	6478155 (no longer available)
Bur 1.0 Composite (coated) (for software version inLab CAM SW ≥ 15.0 only)		Blue	6551696
Bur 2.5 Composite (coated) (for software version inLab CAM SW ≥ 15.0 only)		Blue	6551688
Bur 0.5 sintering metal		Gray	6478080
Bur 1.0 sintering metal		Gray	6478072
Bur 2.5 sintering metal		Gray	6478064
Bur 1.0 metal		Green	6606292
Bur 2.0 metal		Green	6606243

### 6.2.3 Equipping the multi-block holder

The machine has the option of processing up to 6 blocks of different grinding materials in a process at the same time. Equipping with the maximum number of blocks (6) can be achieved by using blocks of a size smaller than or equal to 14x14. At most one block from the blocks of the size 40x19x19 may be processed per process.

During each change, ensure clean contact surfaces of all parts; otherwise, the fixation and the correct positioning cannot be guaranteed. Depending on your choice of materials, also follow the processing instructions of the manufacturer.

#### IMPORTANT

Follow the software dialog for equipping the multi-block holder.  
 Equip the multi-block holder preferably outside the machine.

### Preparing the multi-block holder

The multi-block holder is supplied with separate spherical pressure screws for fixing the material blocks. Use the tool for the block clamp for this.

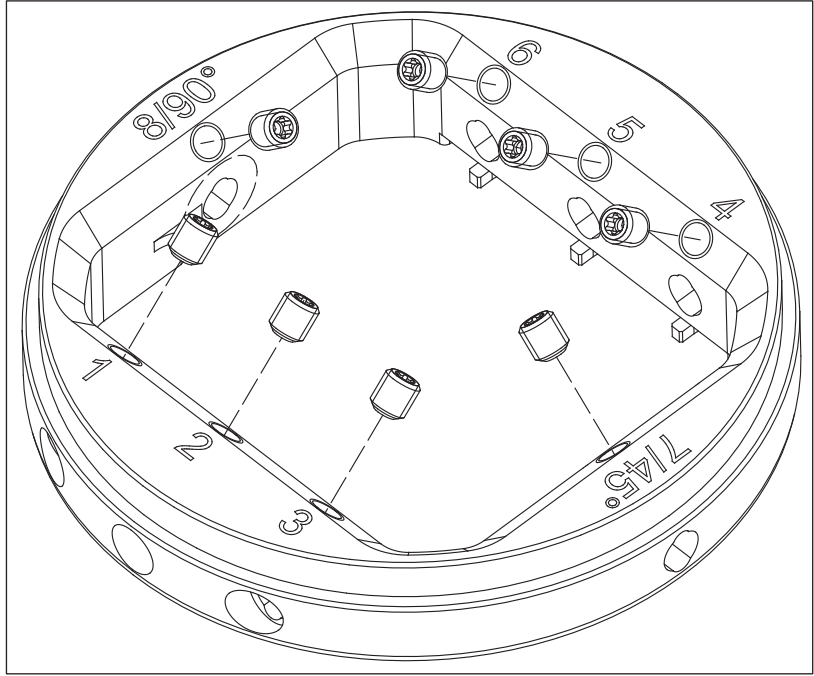

1. Insert the supplied spherical pressure screws in the appropriate places of the multi-block holder and proceed with equipping.

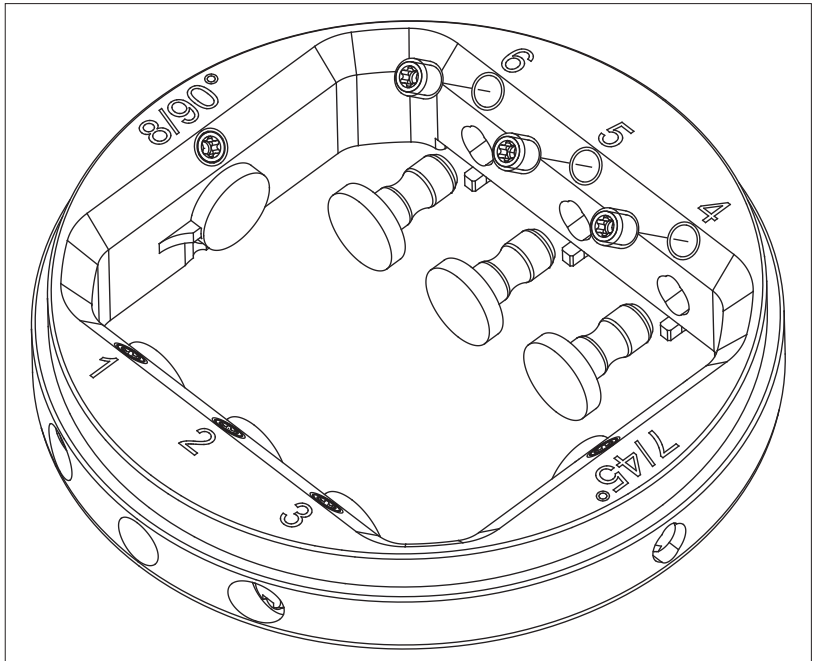

2. Assign block placeholders to the unused positions.

In order to equip the multi-block holder, proceed as follows:

**⚠ CAUTION**

**Risk of injury while reaching out to the processing chamber**

There is the risk of cut injuries and crushing through sharp tools and moving parts.

- Make sure that you do not touch the sharp tools and moving parts.

1. Place the selected block in the proposed block fixation of the multi-block holder at the position defined by the software. The possible positions are marked and numbered on the upper side of the multi-block holder by an engraving.
2. Screw the block down tightly with the spherical pressure screw with the aid of the block clamping tool for the multi-block holder.

### 6.2.4 Loading with the workpiece (round blank)

**⚠ CAUTION**

**Risk of injury while reaching out to the processing chamber**

There is the risk of cut injuries and crushing through sharp tools and moving parts.

- Make sure that you do not touch the sharp tools and moving parts.

During each change, ensure clean contact surfaces of all parts; otherwise, the fixation and the correct positioning cannot be guaranteed. Depending on your choice of materials, also follow the processing instructions of the manufacturer.

The workpiece holder is designed to hold workpieces of different materials in the round blank form. The format for holding is a diameter of  $\varnothing = 98.5$  mm. The workpiece holder automatically moves to the loading/ unloading position.

**In order to load the workpiece holder with a workpiece, proceed as follows:**

1. Open the door of the machine by pressing the Unlock door button.
  - ↳ The mandrel and the workpiece holder have automatically moved to the loading position beforehand.

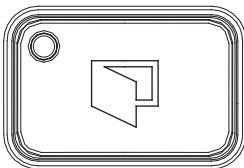

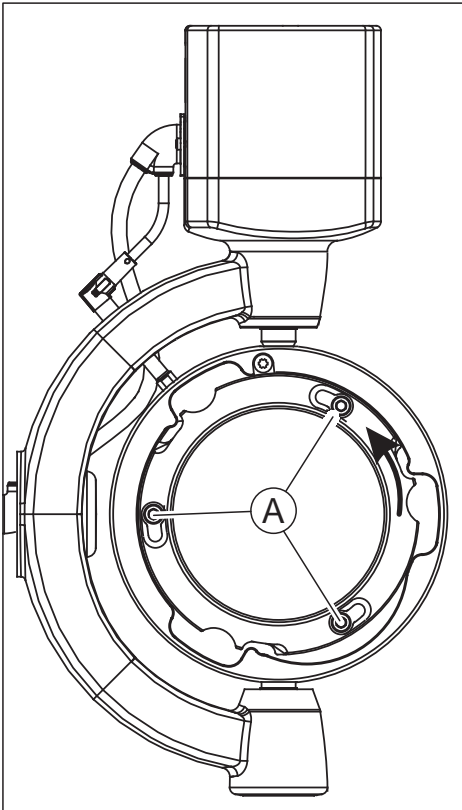

2. Loosen the three screws (A) that are located on the fixing ring of the workpiece holder using the torque wrench for the tool holder.
3. Turn the fixing ring counterclockwise and remove the fixing ring of the workpiece holder.

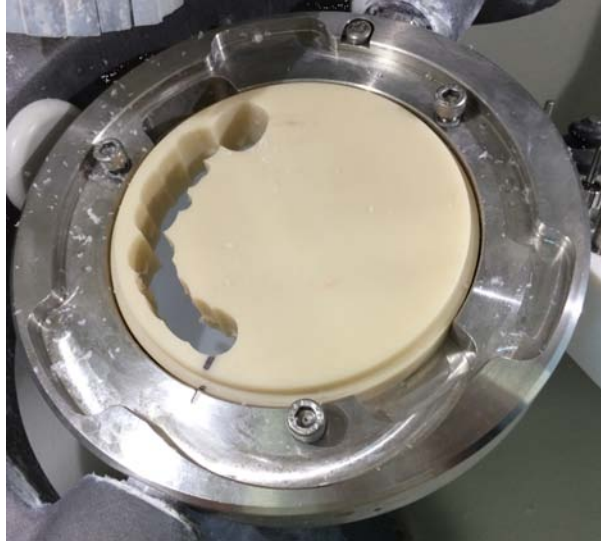

#### IMPORTANT

If a positioning mark is on the work piece, always make sure it matches precisely with the engraved mark on the workpiece holder.



4. Now place the workpiece to be machined, and make sure that the workpiece is parallel to the base and is not slanted. Ensure clean contact surfaces.  
After inserting a workpiece which has not yet been milled attach a positioning marking to the round holder in the same way as the round holder in the same way as the positioning marking to the tool workpiece support. This positioning marking is important for reinserting the workpiece later.  
While inserting an already used workpiece, make sure that the marking on the used workpiece matches with that of the workpiece holder.



5. In order to attach the workpiece, remove the fixing ring and place it back in the workpiece holder. Turn the fixing ring clockwise until the stop.





6. Now slightly tighten the screws on the fixing ring with the help of the torque wrench for the tool holder in an alternating manner. Make sure that the fixing ring is parallel to the base and is not slanted. If the ring is in parallel, firstly tighten the three screws lightly (not with full torque) and then finally tighten the screws in succession using the torque wrench and the pre-selected torque. The required torque is reached if a clicking/ popping sound is heard when tightening the screws. Use only the torque wrench supplied with the workpiece holder from Sirona for fixing the workpiece.
7. Close the door of the machine after inserting and fixing the workpiece, and follow the instructions of the software.

### 6.2.5 Loading with the multi-block holder

#### **⚠ CAUTION**

##### **Risk of injury while reaching out to the processing chamber**

There is the risk of cut injuries and crushing through sharp tools and moving parts.

- Make sure that you do not touch the sharp tools and moving parts.

During each change, ensure clean contact surfaces of all parts; otherwise, the fixation and the correct positioning cannot be guaranteed. Depending on your choice of materials, also follow the processing instructions of the manufacturer.

For the processing of material blocks, the workpiece holder can be equipped with one multi-block holder and with different blocks (see "Equipping the multi-block holder [→ 61]").

**In order to load the workpiece holder with the multi-block holder, proceed as follows:**

1. Open the door of the machine by pressing the Unlock door button.  
 ↳ The mandrel and the workpiece holder have automatically moved to the loading position beforehand.

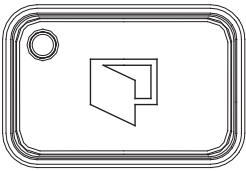

2. Loosen the three screws (A) that are located on the fixing ring of the workpiece holder using the torque wrench for the tool holder.
3. Turn the fixing ring counterclockwise and remove the fixing ring of the workpiece holder.

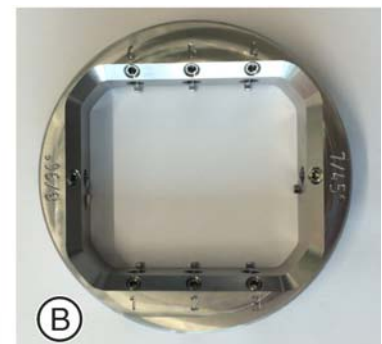
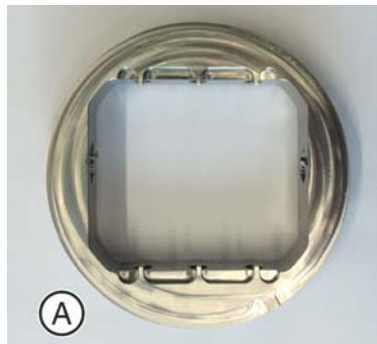
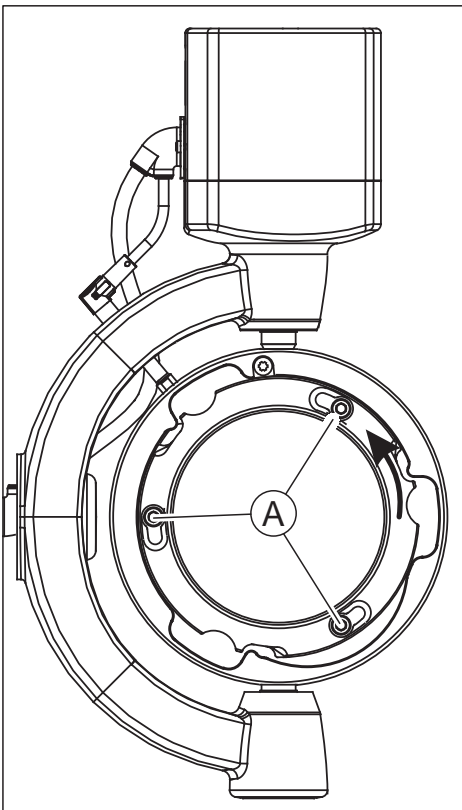

A	Bottom multi-block holder	B	Top multi-block holder
---	---------------------------	---	------------------------

4. Now insert the multi-block holder, making sure that the multi-block holder is parallel to the base and is not slanted. Ensure clean contact surfaces. Make sure that the notch on the block holder is on the bottom non-engraved side of the multi-block holder. Rotate the multi-block holder into the final position using a light rotating movement on the block in the block fixation until it locks into place.



5. In order to attach the multi-block holder, remove the fixing ring and place it back in the workpiece holder. Turn the fixing ring clockwise until the stop.

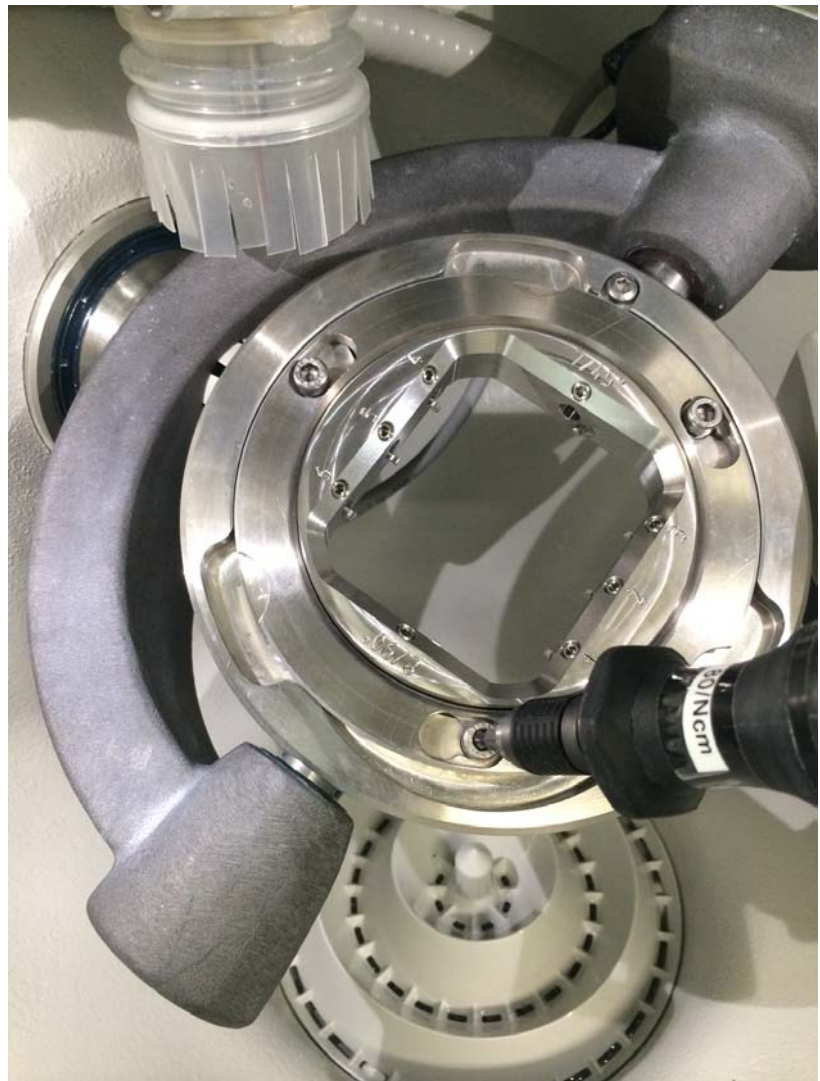

6. Now slightly tighten the screws on the fixing ring with the help of the torque wrench for the tool holder in an alternating manner. Make sure that the fixing ring is parallel to the base and is not slanted. If the ring is parallel, tighten the screws finally using the torque wrench at the preset torque. The required torque is reached if a clicking/ popping sound is heard when tightening the screws. Use only the torque wrench supplied with the workpiece holder from Sirona for fixing the workpiece.
7. Close the door of the machine after inserting and fixing the multi-block holder, and follow the instructions of the software.

### 6.2.6 Process start

Then simply proceed as prompted by the software.

## 7 Maintenance and cleaning

### NOTE

#### Observe country-specific Regulations!

Some countries have legal regulations which require regular safety inspections of electrical devices or systems by the operator.

### NOTE

#### Perform maintenance regularly!

Observe the regular maintenance intervals (see ).

### NOTE

#### Observe error messages

You must observe error messages shown on the display on in the software. If the error message does not disappear even after you have performed the prompted action, contact your service engineer.

### 7.1 Care, cleaning agents, and disinfectants

### NOTE

#### Approved care, cleaning, and disinfecting agents

Use only care, cleaning, and disinfecting agents approved by Dentsply Sirona!

A continuously updated list of approved agents can be downloaded from the Internet on the online portal for technical documents. You can reach this portal at the address:

[www.dentsplysirona.com/manuals](http://www.dentsplysirona.com/manuals)

.Click on the menu item "*General documents*" and then open the "*Care, cleaning and disinfection agents*" document.

If you do not have access to the internet, please contact your dental depot to order the list (REF 59 70 905).

### 7.2 Cleaning the unit with MC Care liquid

1. Clean your unit once per month with the MC Care liquid provided.
2. Please refer to the operating instructions provided with the MC Care liquid.

## 7.3 Maintenance intervals

Interval	Scope of maintenance
Before all sintering metalworking	See section "Before processing sintering metal materials [→ 84]".
After all sintering metalworking	See section "After processing sintering metal materials [→ 84]".
Before all titanium metalworking	See section "Before processing titanium workpieces [→ 88]".
After all titanium metalworking	See section "After processing / before changing to processing another material [→ 94]".
Before each wet processing	Check the filling level using the <i>min</i> / <i>max</i> marking and top up with coolant mixture if required.
Daily (recommended)	Use suction on and/or wipe out the processing chamber at the end of the working day.
	Clean the collet at the end of the working day in accordance with these Operating Instructions.
Weekly	Archive and adjust completely processed rounds and blocks (*.blc files) in the selected data folder of the inLab CAM software.
	Archive and adjust restoration data in the selected data folder of the inLab CAM software.
	Check coolant nozzles and clean if necessary.
	Check filter regulators and clean if necessary.
	Check that the suction bellows are working properly.
	Clean the collet in accordance with these Operating Instructions.
Monthly	Check and clean the upper suction hose on the mandrel.
	Check and clean the lower suction hose.
	Check coolant nozzles and clean if necessary.
	Change the coolant filter.
	Change the coolant.
	Check the condensate tank on the filter regulator and drain the condensate if necessary.
	Clean the outer surfaces of the machine.
Annually (recommended)	System maintenance by service technician, using maintenance kit in-Lab MC X5 (REF 65 33 538).

## 7.4 Cleaning surfaces

### NOTE

Do not allow liquids to run into the ventilation slots!

### 7.4.1 Disinfecting

Wipe surfaces down with a surface disinfectant (wiping disinfectant).

Observe the manufacturer's instructions regarding restrictions for use.

### 7.4.2 Protection against medicaments

Due to their high concentrations and the substances they contain, many medicaments can dissolve, etch, bleach or discolor surfaces.

### NOTE

#### Damage to the surface

Clean the surface immediately with a moist cloth and a cleaning agent.

### 7.4.3 Cleaning

Remove dirt, grime and disinfectant residue regularly using mild, commercially available cleaning agents.

## 7.5 Maintenance for the tool mandrel

The tool mandrel is a high-frequency mandrel (HF-mandrel).

### Steel ball bearings

The ball bearings of the HF-mandrel are equipped with permanent grease lubrication. They are maintenance-free.

Do not lubricate the bearings.

Do not allow greases, oils or detergents to enter the openings of the HF-mandrel.

### Service

#### CAUTION

##### **Risk of injury and/or damage to the unit**

Observe the following:

- > Repair and maintenance work - other than the activities described in this operating manual - may be performed only by qualified personnel.
- > Shut down the machine in which the tool mandrel is installed before starting any cleaning and maintenance works.
- > Clean the tool mandrel using ultrasound, a jet of steam, compressed air, or the like.
- > Always use the cleaning brush from the care kit.
- > Never allow detergents (such as spray cleaner, degreaser, etc.) to enter the interior of the tool mandrel.
- > Use only the original collet chuck.

The HF-mandrel must be stopped before any maintenance work.

Make sure that the shaft of the HF-mandrel is absolutely stationary before servicing. Read this chapter "Maintenance and cleaning" carefully before servicing. The HF-mandrel should be serviced only by qualified personnel. All safety messages and regulations must be adhered to.

### cleaning

Before starting the daily work check whether all surfaces are properly cleaned and are free from dust, grease, coolant, processing residues and metal particles. The surfaces must not be damaged.

### 7.5.1 Service kit



The machine comes with a service kit for maintenance of the HF-mandrel. This kit consists of:

- Dummy tool
- Isoflex Topas NB 52 lubricant
- Cylinder brush with eyelet
- Cleaning cone made of felt (felt cone)
- Chuck key SW5.5
- Chuck key SW6.0

### 7.5.2 Cleaning and maintenance of the collet chuck / collet chuck change

- In order to guarantee safe and accurate function of the HF mandrel, all surfaces of the HF mandrel, the HF-mandrel receptacle, the tool receptacle and the tool holder should be clean.
- Before starting the daily work check whether all surfaces are properly cleaned and are free from dust, grease, coolant, processing residues and metal particles. The surfaces must not be damaged.
- Before each day's start, the HF-mandrel is operated automatically at an optimally adjusted speed with the tool clamped (without processing) to preheat and protect the grease lubrication of the bearing. The HF-mandrel attains its operating temperature as a result. This function is automatically controlled by the software.
- Do not use compressed air, ultrasound and a jet of steam to clean the HF-mandrel. Dirt can penetrate into the storage area.

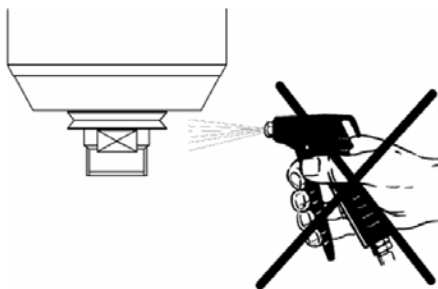

Proceed as follows to clean the area:

#### NOTE

**Do not interrupt the maintenance/changing collet chuck process!**

If you have started the process once, do not cancel the operation. Do not turn off the machine during the changing process and do not disconnect the power supply to the machine.

1. Start the inLab MC X5.



2. Start the inLab CAM software.
3. In the system start menu click on "Configuration".
4. Click "Machine and Instrument tray Management".
5. Click on the "inLab MC X5".
6. Click "Service".
7. Click "Spindle Maintenance".
  - ↳ The machine moves into the position for spindle maintenance.
  - ↳ The dummy tool is stored in the slot provided.
  - ↳ The collet chuck is opened.
  - ↳ The sealing air is switched on.
8. Remove the suction guard.
9. Now rotate the collet chuck out of the mandrel with the intended tool.

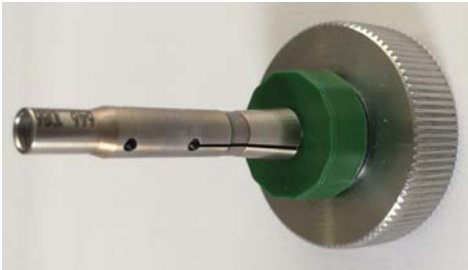

10. Clean the inner cone of the shaft of the HF-mandrel with the felt cone from the service kit. The inner cone must be free of chips and dirt. Then, clean the tool cone with a clean soft cloth or a clean, soft brush.
11. Now clean the collet chuck and the collet chuck holder with a clean soft brush as well as the cylinder brush with eyelet. Alternatively use a new collet chuck for the next steps.



#### NOTE

##### Damage to the collet chuck

The collet chuck may be damaged if you use a different lubricating grease or oil.

- Only use the grease for collet chuck from the service kit.
- Do not use a different lubricating grease or oil.



12. After cleaning, apply a thin film of grease on to the cone of the collet chuck. This improves the lubrication and increases the clamping force of the collet chuck.

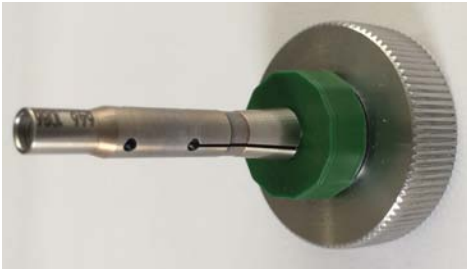

13. Screw the covers back onto the mandrel. Tighten until the bolting tool clicks. This means that the intended torque has been achieved.
14. Pull the suction guard over the mandrel.
15. Confirm completion of the maintenance in the software.
  - ↪ The machine retrieves the dummy tool.
  - ↪ The machine moves to the loading position.

### 7.5.3 During longer downtimes

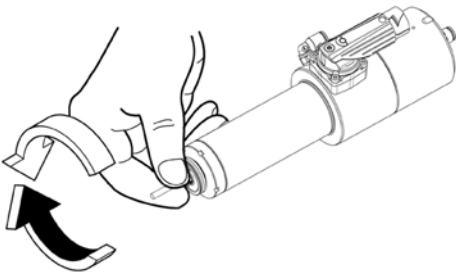

- Turn the shaft of the HF-mandrel at least 10 times by hand every 3 months.

#### NOTE

##### **Do not interrupt the automatic run-in time!**

Do not interrupt the process. Do not turn off the machine during the run-in time and do not disconnect the power supply to the machine.

The downtimes of the machine are automatically saved.

In the case of longer downtimes, an automatic run-in time of the mandrel occurs. This run-in time occurs after switching on the machine and can take several minutes to complete, depending on the downtime.

### 7.5.4 Tool has broken or not been stored

If a tool breaks during the machining process, it can no longer be stored automatically; proceed as follows:

#### CAUTION

##### **Risk of injury**

A broken tool can be hot and sharp-edged.

- Wait until the tool is cooled.
- Use gloves to protect against injury.

1. Access the service mode for maintenance of the collet chuck in the software and continue to follow the instructions of the software.
2. Remove the collet chuck, as described in the Section "Cleaning and maintenance of the collet chuck / collet chuck change [→ 72]".
3. Remove the remainders of the broken tool from the collet chuck.
4. Clean the collet chuck and insert the collet chuck back, as described in Section "Cleaning and maintenance of the collet chuck / collet chuck change [→ 72]".
5. Continue to follow the instructions of the software.

## 7.6 Suction system

### 7.6.1 Suction bellows

The machine is equipped with suction bellows for the extraction of dust. Check the suction bellows regularly for proper operation. If the slats are broken, replace the suction bellows.

1. Pull the suction bellows off the mandrel using the rubber handles.
2. Use new suction bellows (REF 6496686) and fasten it by first engaging the back part of the bellows into the groove of the mandrel.
3. Then pull the suction bellows over the mandrel by holding at the two front rubber handles so that the bellows are engaged on all sides.

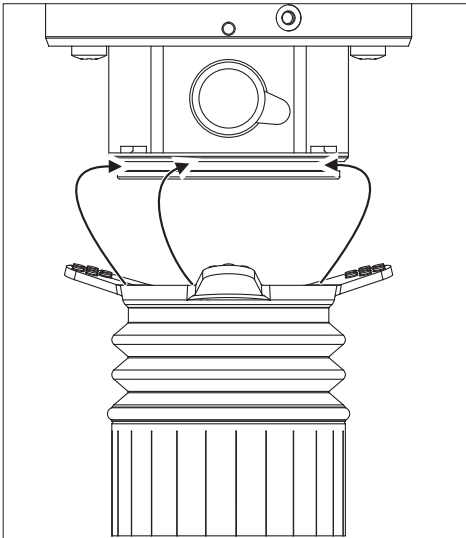

### 7.6.2 Mandrel suction

The machine is equipped with mandrel suction. Check the mandrel suction monthly for proper operation.

1. Disconnect the suction hose of the mandrel suction from the mandrel.
2. Disconnect the suction hose of the mandrel suction (A) in the processing chamber.
3. Check the suction hose for any deposits.
4. Clean the suction hose, if necessary, by blowing compressed air through it.
5. Should the hose be defective, replace it with the correct spare part (REF 6475029).
6. Reattach the suction hose to the mandrel suction as well as the processing chamber (A).

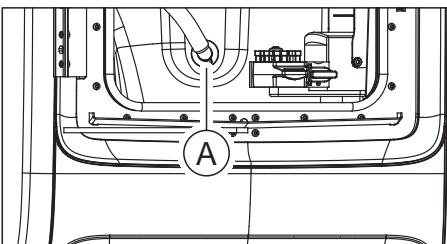
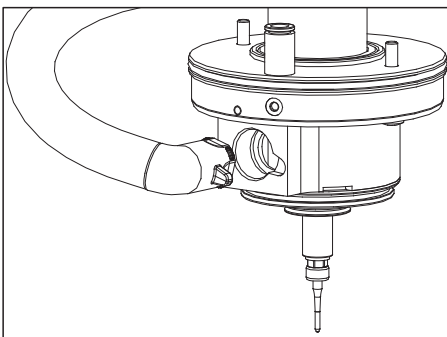

### 7.6.3 Processing chamber screen

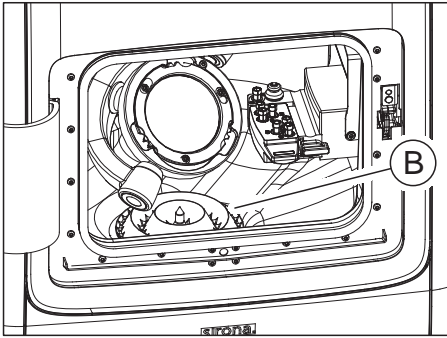

The machine is equipped with a processing chamber screen (B) for collecting material residues. Check the screen regularly.

If there are many chips and machining residues on the screen of the processing chamber, remove it, and empty it.

## 7.7 Filter regulator

The machine is equipped with a filter regulator, which ensures, among other things, the air quality in the system.

Check the filter regulator weekly for proper operation.

1. Check if condensate has accumulated in the separation vessel (A).
2. If condensate has accumulated here, drain it by pressing the drain plug (B).
3. Then, make sure that the drain plug is locked again properly.
4. Check that 7 bar / 0.7 MPa / 102 psi pressure is in contact on the filter regulator.

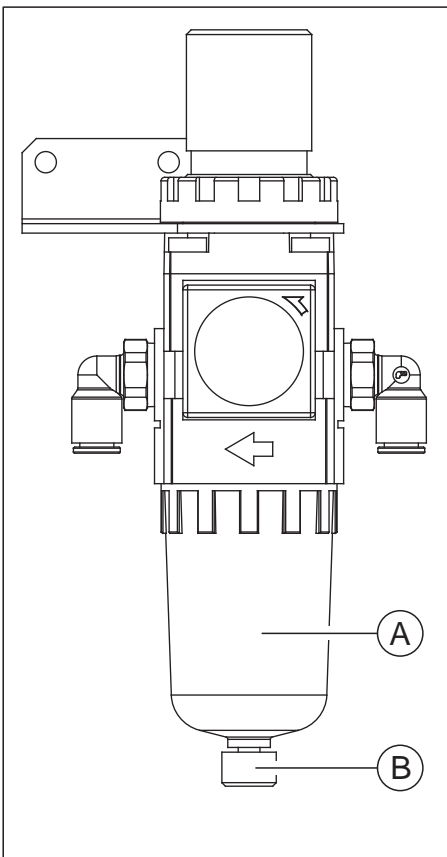

## 7.8 Coolant system

### CAUTION

#### Risk of injury

There is risk of injury through sharp-edged restorations as well as sharp-edged material residues in the tank.

- Pay attention to the sharp-edged restorations / material residues after processing, during cleaning and coolant changes.

### NOTE

#### Check coolant level

Before every wet processing check the coolant level using the min / max marking. Top up the coolant if necessary.

The machine is equipped with a coolant circuit for wet processing. This must be checked and maintained regularly. The coolant circuit includes the coolant nozzles and the tank system.

### 7.8.1 Coolant nozzles

The machine is equipped with three coolant nozzles for cooling the tool.

Check the nozzles monthly for proper operation. To do this, proceed as follows:

1. Remove the suction bellows from the mandrel (see "Suction bellows [→ 76]").
2. Start the rinsing process in the machine configuration menu in the inLab software on the machine.
3. Check the coolant jets impinge on the tool in a properly bundled way.
4. Next remove any foreign bodies in the coolant nozzles carefully using a probe. Use a spray (if available) and a cleaning wire.
5. Mount the suction bellows on the mandrel (see "Suction bellows [→ 76]").

## 7.8.2 Changing the tank filter

### NOTE

#### Change the filter insert regularly

We recommend changing the filter insert monthly (REF 6387067).

If a message appears stating that the water pressure is too low, please check whether the filter has become clogged or the tank filling level has fallen below the "min" marking.

Use only filter cartridges approved by Sirona!

To change the filter, proceed as follows:

- ✓ The unit is switched on.
- ✓ No machining process is running.

### NOTE

#### Risk of damage to the hoses!

Pulling at the inlet and outlet hoses may damage them.

- Always draw off the hoses at the pipe piece.

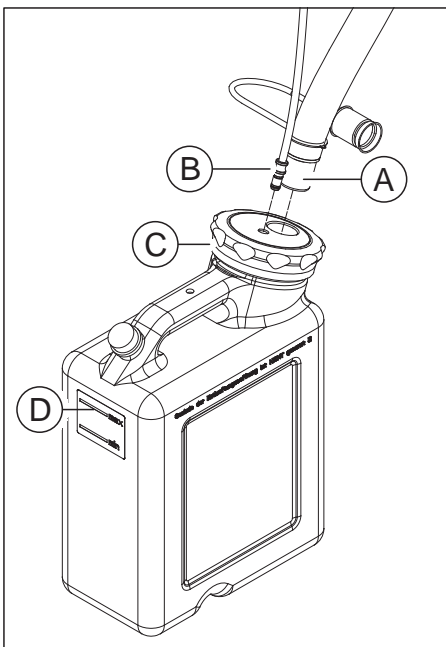

1. Draw off the machine-sided tank inlet hose (A) with the large diameter as well as the thin coolant supply hose (B) from the tank. Pay attention to leaking residual liquid and catch it with a separate collecting container, if necessary.
2. Open the tank lid clip (C) and pull the filter system out. Pay attention to any remainder liquid.
3. Remove the filter cartridge using a separate collection container or sink.
4. Install a new filter cartridge (REF 6387067) on the filter system. Make sure of correct fit.
5. Change the coolant if necessary (see Replace the coolant when using DENTATEC (for material classes PMMA/wax, composite and grinding materials) [→ 80]).
6. Place the filter system in the tank.
7. Lock the tank with the tank lid clip.
8. Connect the tank inlet hose (A) with the large diameter as well as the thin coolant supply hose (B) again to the tank system.

### 7.8.3 Replace the coolant when using DENTATEC (for material classes PMMA/wax, composite and grinding materials)

#### NOTE

##### Damage to the pump and the tool mandrel!

Too high a proportion of ceramic in the coolant will damage the pump and the tool mandrel.

Change the coolant regularly!

We recommend changing the coolant after one month at the latest.

#### 7.8.3.1 Preventing odors

All coolant additives contain a biodegradable preservative. Despite this, however, odors may still develop under unfavorable conditions.

Observe the following:

- Change the coolant at least once a month.
- Drain the tank if you do not intend to operate the unit for more than one week.
- Clean the tank if the odors recur.
- Add the coolant additive DENTATEC and fill the tank up to the brim with water. Let it stand for at least 24 hours and then rinse it out thoroughly with water once again.

#### NOTE

##### Damage to surfaces!

In the undiluted state, the coolant additive DENTATEC disintegrates plastic surfaces and can cause discoloration.

- > Do not place DENTATEC on the unit.
- > Do not spill DENTATEC.

#### NOTE

##### Approved coolant additive

Use only DENTATEC as a coolant additive.



### 7.8.3.2 Complete a coolant change

#### CAUTION

##### Risk of injury

There is risk of injury through sharp-edged restorations as well as sharp-edged material residues in the tank.

- Pay attention to the sharp-edged restorations / material residues after processing, during cleaning and coolant changes.

#### NOTE

##### Checking whether the available connections are leakproof

Check the connections after each coolant change for any leaking fluids under the unit or in the area.

To change the coolant, proceed as follows:

- ✓ The unit is switched on.
- ✓ No machining process is running.

#### NOTE

##### Risk of damage to the hoses!

Pulling at the inlet and outlet hoses may damage them.

- Always draw off the hoses at the pipe piece.

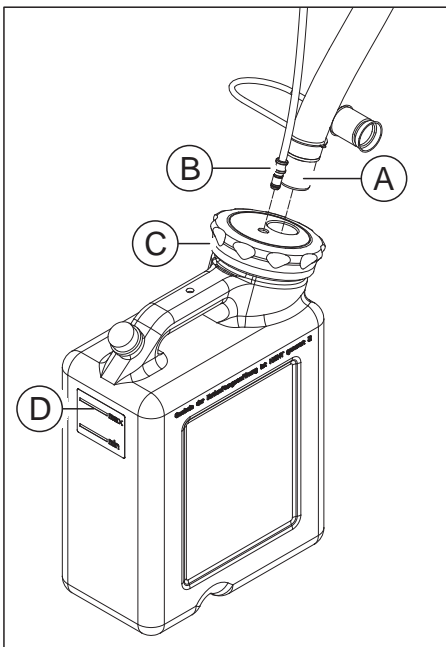

1. Draw off the machine-sided tank inlet hose (A) with the large diameter as well as the thin coolant supply hose (B) from the tank. Pay attention to leaking residual liquid and catch it with a separate collecting container, if necessary.

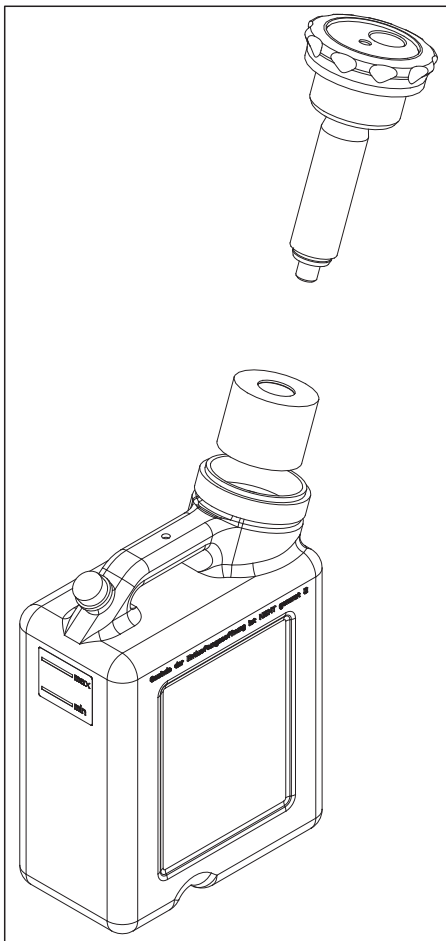

2. Open the tank lid clip (C) and pull the filter system out. Pay attention to any remainder liquid.
3. Drain two-thirds of the coolant tank.
4. Shake the tank.
5. Drain the coolant tank.

#### NOTE

##### **Foaming not permissible!**

If any cleaning agents are used, this will create foam, which is not permitted.

- > Do not use any cleaning agents.

6. Fill the tank with water up to the mark (max, D) (approx. 10 liters).

#### NOTE

##### **Damage to surfaces!**

When undiluted, DENTATEC grinding additive etches plastic surfaces and can cause discoloration.

- > Do not place DENTATEC on the unit.
- > Do not spill DENTATEC.

7. Add approx. 250 ml DENTATEC to the tank. The mixture ratio is: 1l water to 0.025l DENTATEC.
8. Place the filter system in the tank.
9. Lock the tank with the tank lid clip.
10. Connect the tank inlet hose (A) with the large diameter as well as the thin coolant supply hose (B) again to the tank system.

## 7.9 Procedure for processing sintering metal

### 7.9.1 Important information

#### NOTE

**Observe the safety information from the material manufacturer**

Observe the safety instructions regarding occupational safety and disposal referred to in the material manufacturer's operating instructions. Dirty filters, tanks and metal residue must be disposed of appropriately in accordance with these specifications.

#### IMPORTANT

Use a waterproof receptacle with a nominal volume of 10-20l as a collecting vessel for changing the water (e.g. a commercially available 10l or 20l plastic bucket). When selecting the collecting vessel, bear in mind that it will also serve as a transporting container for disposal and is not reusable.

#### IMPORTANT

Wearing protective waterproof gloves is recommended.

#### IMPORTANT

Sirona recommends, however, that you use an additional standard tank which is only used for processing sintering metal materials. This is available individually as "Coolant tank complete (REF: 63 85 137)" or in combination with a new tool magazine and the accompanying sintering metal grinder "Starter Kit Sintering Metal inLab MC X5 (REF 65 61 986)".

#### IMPORTANT

Ask your disposal company whether the filter waste needs to be correctly sorted for disposal.

### IMPORTANT

Once the water has been changed, the collecting vessel will contain a mixture of sintering metal slurry (in mixed operation, there will also be other materials) and water. The machining particles dispersed in the water will settle to the bottom of the collecting vessel within 24h, resulting in a clear separation between the water and the settled solid matter.

The clear water can then be removed or siphoned off from the collecting vessel. The collecting vessel can be used until it is max. half-full of grinding slurry (solid matter) or until the permitted weight for the collecting vessel used has been reached. 5 L of correctly sorted sintering metal machining waste corresponds to 40 kg in weight depending on the sintering metal alloy.

### IMPORTANT

Sirona recommends using a separate tool magazine (REF: 64 78 528) for equipping sintering metal tools in order to prevent contamination on other tools.

### IMPORTANT

Sirona recommends using separate suction bellows (REF: 64 96 686) for processing sintering metal materials.

## 7.9.2 Before processing sintering metal materials

1. Change to the suction bellows intended for sintering metal processing (for notes on making the change, see "Suction bellows [→ 76]").
2. Connect the tank intended for sintering metal processing (to connect it, see "Connecting the coolant tank [→ 30]").

## 7.9.3 After processing sintering metal materials

1. Clean the drain hose to the tank using suitable cleaning brushes (e.g. in those contained in the "Starter Kit Sintering Metal inLab MC X5 REF 65 61 986").
2. Perform an automatic cleaning process (without a clamped round) via the service menu of the inLab CAM SW.
3. Separate the tank for sintering metal material processing and connect the tank for the remaining materials.
4. Change back to the suction bellows for the non-sintering metal materials.
5. Wipe off the compartment where necessary.

## 7.9.4 Cleaning the coolant tank

### NOTE

#### The tank may become unusable

Regularly check the condition of the deposited solids and clean the tank in good time to prevent the solids from hardening in the tank (after approx. 5 discs, the milling residue should be emptied into a collection tank).

### 7.9.4.1 Emptying the cooling tank

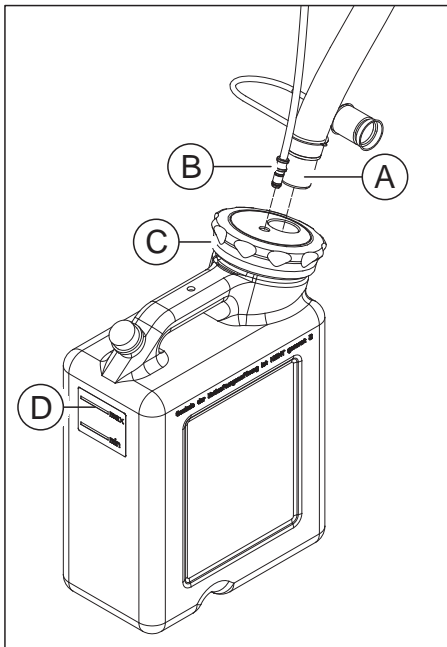

- ✓ There is a 10l-20l collecting tank available.
- 1. Draw off the machine-sided tank inlet hose (A) with the large diameter as well as the thin coolant supply hose (B) from the tank. Pay attention to leaking residual liquid and catch it with a separate collecting container, if necessary.
- 2. Leave the tank to rest overnight until the particles have settled on the bottom.
  - ↳ The particles have largely settled on the bottom.
- 3. Open the tank lid clip (C) and pull the filter system out. Pay attention to any remainder liquid.
- 4. Clear the coolant (unclouded liquid) by carefully pouring it out until the remaining solids become visible. Ensure that approximately 1/5 of the coolant remains in the tank.
- 5. Pan the tank vigorously several times in circular movements until the deposited solids once again mix with the remaining coolant. Prevent the fluid from escaping from the tank.
- 6. Empty approx. 1/2 of the remaining contents of the tank into the collecting vessel provided.
- 7. Pan the tank vigorously in circular movements again until as much of the remaining solids as possible can be rinsed out using the remaining coolant.
- 8. Empty the residual contents into the collecting vessel provided.

### 7.9.4.2 Rinsing and emptying the water tank

1. Fill the tank approx. 1/4 full with water.
2. Pan the tank several times in circular movements.
3. Empty the residual contents into the collecting vessel provided. Pan the tank several times in circular movements in the meantime where necessary.

### 7.9.5 Filling the coolant tank

1. Fill the tank with water up to the mark (max, **D**) (approx. 10 liters).

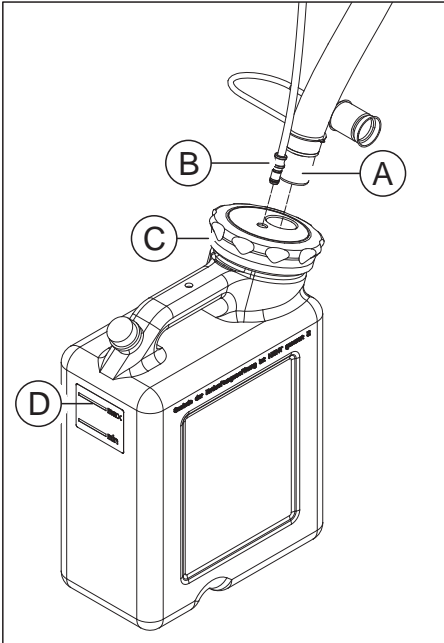

2. Place the filter system in the tank.
3. Lock the tank with the tank lid clip.
4. Reconnect the coolant drainage hose (**A**) with the large diameter as well as the thin coolant supply hose (**B**) to the tank system.

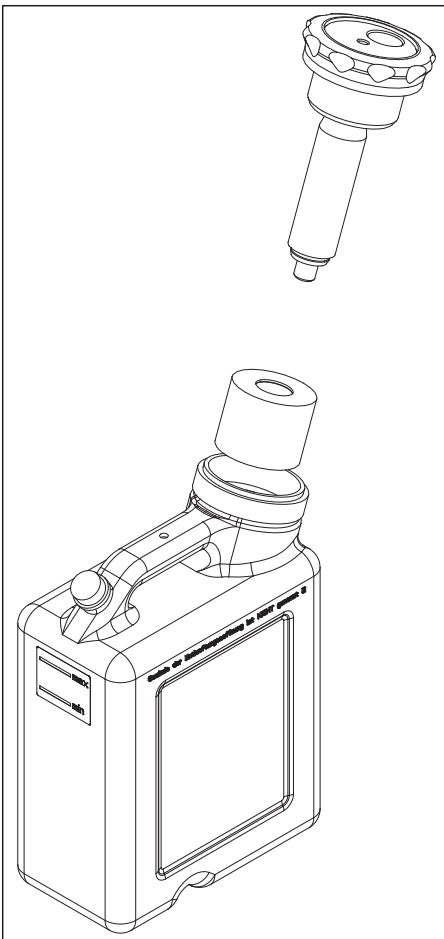

## 7.10 Procedure when processing Medentika-PreFace® abutment semi-finished products made of titanium

### 7.10.1 Important information

#### CAUTION

##### Risk of injury

There is risk of injury through sharp-edged restorations as well as sharp-edged material residues in the tank.

- Pay attention to the sharp-edged restorations / material residues after processing, during cleaning and coolant changes.

#### NOTE

##### Observe the safety information from the material manufacturer

Observe the safety instructions regarding occupational safety and disposal referred to in the material manufacturer's operating instructions. Dirty filters, tanks and metal residue must be disposed of appropriately in accordance with these specifications.

#### IMPORTANT

When processing workpieces from the material class metal (Medentika-PreFace® abutment semi-finished products), use the "Starter Kit Preface Abutments Medentika" (REF 6597210). It contains all of the relevant equipment required to process workpieces (holders, tools, coolant lubricant additive DentaLub, tool magazine and two coolant tanks. Use one of the tanks for processing and the other to clean the system.)

#### IMPORTANT

Use a coolant-lubricant mix of water and the coolant lubricant additive DentaLub to process titanium workpieces.

#### IMPORTANT

After all processing using the coolant lubricant additive DentaLub before switching to another material, perform a cleaning process with then intended cleaning tank (see "After processing / before changing to processing another material [→ 94]").

#### IMPORTANT

Ask your disposal company whether the filter waste needs to be correctly sorted for disposal.

## 7.10.2 Before processing titanium workpieces

### CAUTION

#### **Risk of injury while reaching out to the processing chamber**

There is the risk of cut injuries and crushing through sharp tools and moving parts.

- Make sure that you do not touch the sharp tools and moving parts.

### CAUTION

#### **Risk of injury through cutting and grinding tools**

There is risk of cuts through sharp edges of accessible parts and the use of rotating cutting and grinding tools that are sharp and/or pointed.

### CAUTION

#### **Risk of injury through sharp-edged restorations and material residues**

There is risk of injury through sharp-edged restorations as well as sharp-edged material residues.

- Remove the restored objects and material residues carefully after the processing.
- Pay attention to the sharp-edged material residues while cleaning the processing chamber.

### 7.10.2.1 Filling and connecting the coolant tank

Connect the tank intended for titanium processing. In addition, follow the instructions for filling the tank with the coolant DentaLub when processing titanium workpieces.

### NOTE

#### **The tank may become unusable**

Regularly check the condition of the deposited solids and clean the tank in good time to prevent the solids from hardening in the tank. Circulate the contents of the tank when they are not being used by swirling the tank in circular movements.



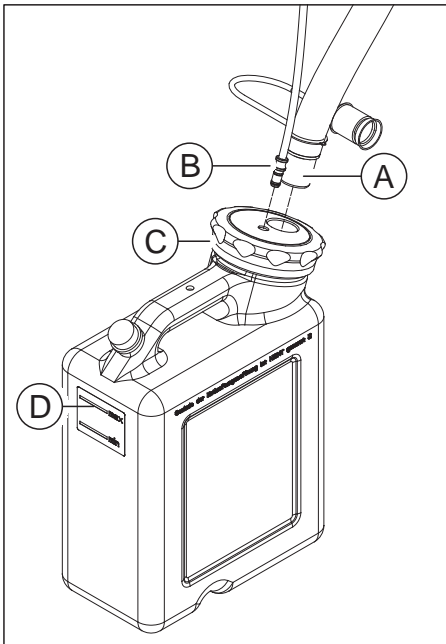

1. Add one bottle of coolant lubricant additive DentaLub (REF 6597228) to an empty tank.
2. Fill the tank with water up to the mark (max, **D**) (approx. 10 liters).

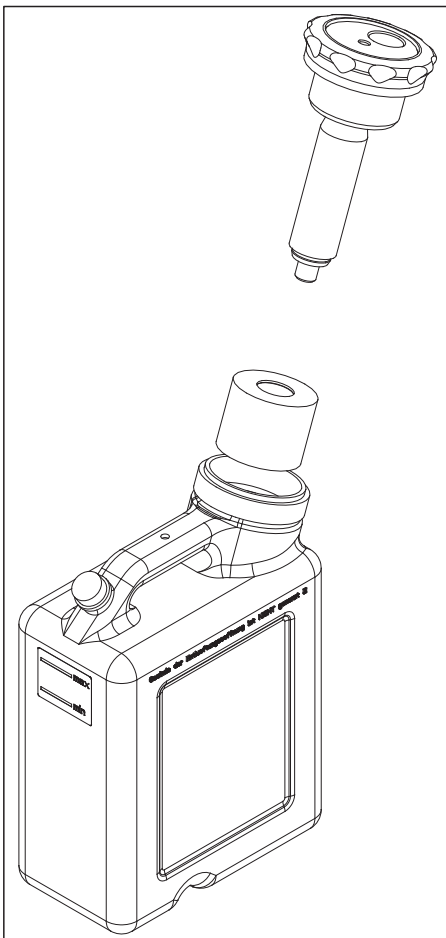

3. Place the filter system in the tank.
4. Lock the tank with the tank lid clip.
5. Reconnect the coolant drainage hose (**A**) with the large diameter as well as the thin coolant supply hose (**B**) to the tank system.

### 7.10.2.2 Equipping the workpiece holder for Medentika-PreFace® semi-finished products

The machine has the option of processing up to 6 Medentika-PreFace® Abutment semi-finished products in one process at the same time.

During each change, ensure clean contact surfaces of all parts; otherwise, the fixation and the correct positioning cannot be guaranteed. Also follow the processing instructions of the manufacturer.

#### IMPORTANT

Follow the software dialog for equipping the Medentika-PreFace® holder.

Equip the holder preferably outside the machine.

In order to equip the Medentika-PreFace® holder, proceed as follows:

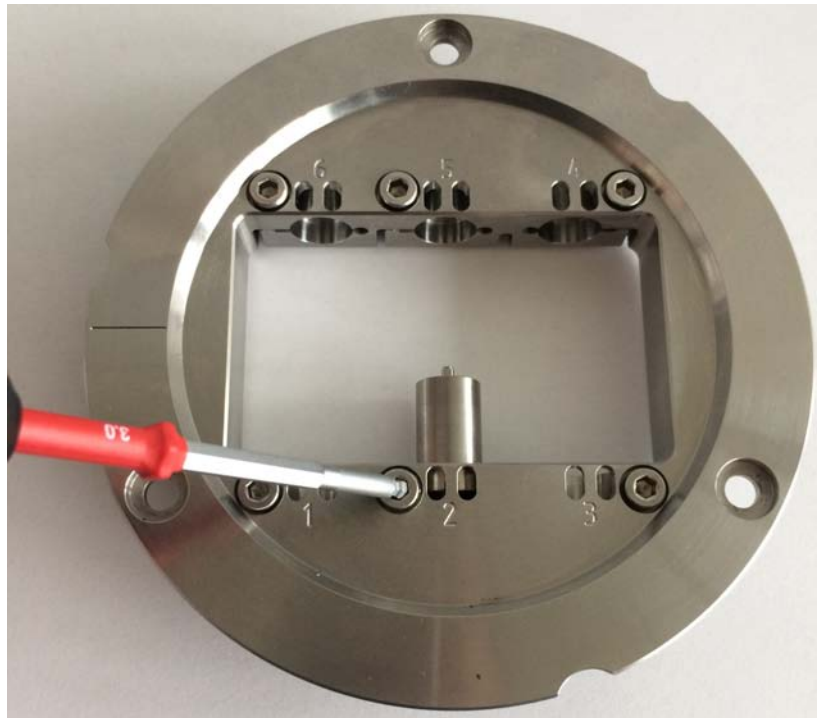

1. Place the selected Medentika-PreFace® semi-finished product in the proposed fixation of the PreFace® holder at the position defined by the software. The possible positions are marked and numbered on the upper side of the multi-block holder by an engraving.
2. Screw the semi-finished product with the spherical pressure screw with the aid of the block clamping tool for the PreFace® holder. The required torque is reached if a clicking/ popping sound is heard when tightening the screws. Use only the torque wrench supplied with the PreFace® holder from Sirona for fixing the workpiece.

### 7.10.2.3 Loading inLab MC X5 with Medentika PreFace® holders

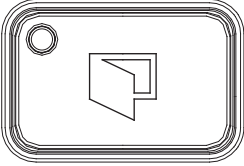

1. Open the door of the machine by pressing the Unlock door button.  
↳ The mandrel and the workpiece holder have automatically moved to the loading position beforehand.

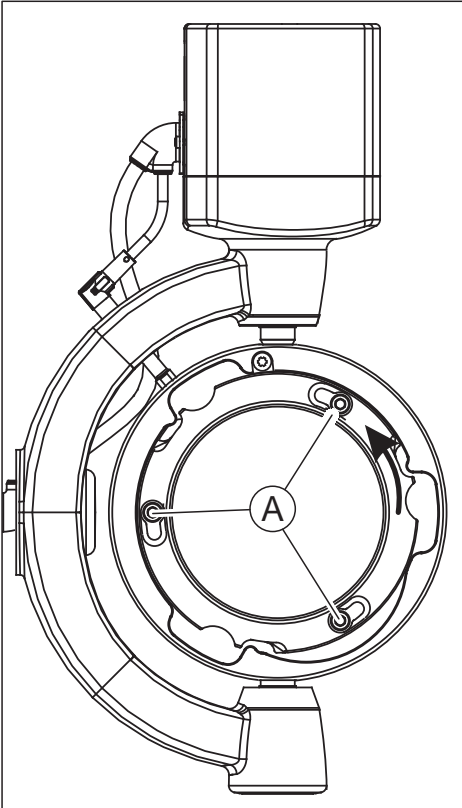

2. Loosen the three screws (A) that are located on the fixing ring of the workpiece holder using the torque wrench for the tool holder.
3. Turn the fixing ring counterclockwise and remove the fixing ring of the workpiece holder.



4. Remove the three screws (A).

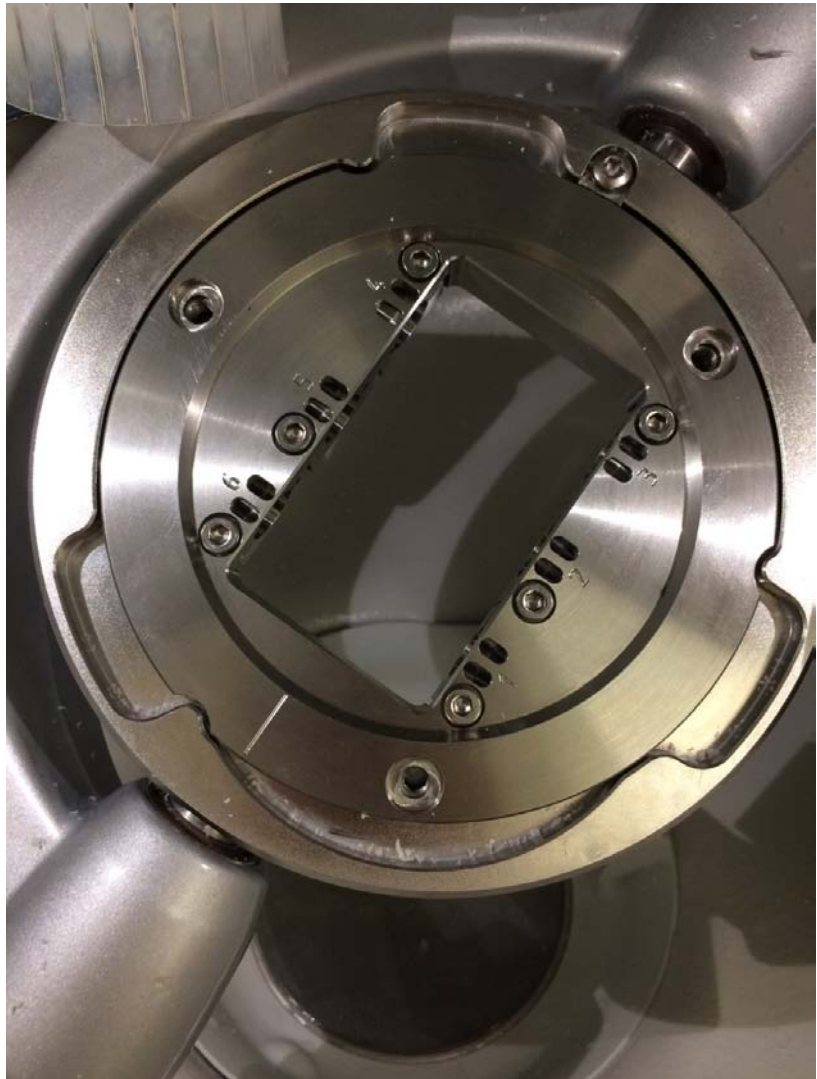

5. Place the Medentika-PreFace® holder into the machine. Make sure that the PreFace® holder is parallel to the base and is not slanted. Ensure clean contact surfaces. Make sure that the notch on the holder is on the bottom non-engraved side of the holder. Rotate the multi-block holder into the final position using a light rotating movement on the holder in the block fixation until it locks into place.



6. To fasten the PreFace® holder, place the three screws (A) back into the respective fixation. Make sure that the thread does not tilt during this step. Now slightly tighten the screws with the help of the torque wrench for the tool holder in an alternating manner. Tighten the screws finally using the torque wrench at the preset torque. The required torque is reached if a clicking/ popping sound is heard when tightening the screws. Use only the torque wrench supplied with the PreFace® holder from Sirona for fixing the workpiece.
7. Close the door of the machine after inserting and fixing the PreFace® holder, and follow the instructions of the software.

### 7.10.3 After processing / before changing to processing another material

#### 7.10.3.1 Retrofitting the machine

##### CAUTION

###### **Risk of injury while reaching out to the processing chamber**

There is the risk of cut injuries and crushing through sharp tools and moving parts.

- Make sure that you do not touch the sharp tools and moving parts.

##### CAUTION

###### **Risk of injury through cutting and grinding tools**

There is risk of cuts through sharp edges of accessible parts and the use of rotating cutting and grinding tools that are sharp and/or pointed.

##### CAUTION

###### **Risk of injury through sharp-edged restorations and material residues**

There is risk of injury through sharp-edged restorations as well as sharp-edged material residues.

- Remove the restored objects and material residues carefully after the processing.
- Pay attention to the sharp-edged material residues while cleaning the processing chamber.



1. Unscrew the Medentika-PreFace® holder.

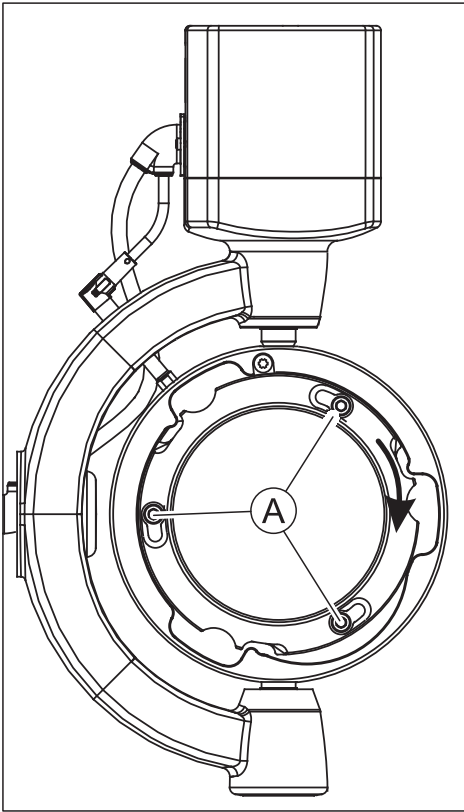

2. Tighten the screw (A) again at the respective point.
3. Insert the fixing ring.
4. Separate the coolant tank from the machine for processing titanium workpieces.
5. Connect the tank for cleaning (tank contents: water without coolant additive).
6. Perform an automatic cleaning process (with a clamped Medentika-PreFace® holder) via the service menu of the software inLab CAM SW.
7. Wipe off the compartment. Concentrate in particular on any accumulations of metal shavings at the front door seal.

#### 7.10.3.2 Cleaning the drain sieve

- > Empty the drain sieve after processing no more than 6 PreFace® abutments.



### 7.10.3.3 Change the coolant

#### ⚠ CAUTION

##### Risk of injury

There is risk of injury through sharp-edged restorations as well as sharp-edged material residues in the tank.

- Pay attention to the sharp-edged restorations / material residues after processing, during cleaning and coolant changes.

#### IMPORTANT

When disposing of the tank contents, also follow the instructions in the safety data sheet of the DentaLub coolant lubricant additive.

#### NOTE

##### Checking whether the available connections are leakproof

Check the connections after each coolant change for any leaking fluids under the unit or in the area.

To change the coolant, proceed as follows:

- ✓ The unit is switched on.
- ✓ No machining process is running.

#### NOTE

##### Risk of damage to the hoses!

Pulling at the inlet and outlet hoses may damage them.

- Always draw off the hoses at the pipe piece.

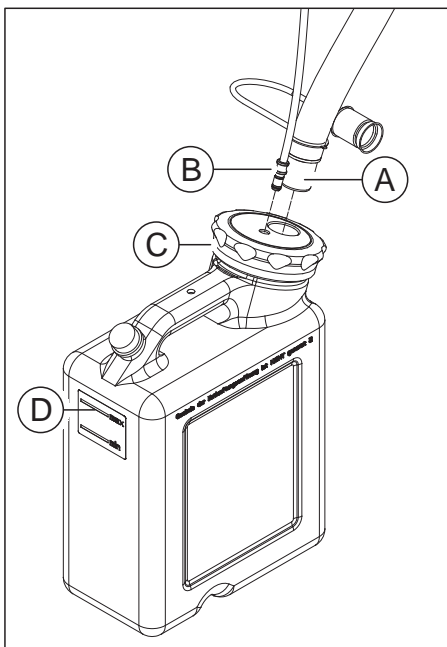

1. Draw off the machine-sided tank inlet hose (A) with the large diameter as well as the thin coolant supply hose (B) from the tank. Pay attention to leaking residual liquid and catch it with a separate collecting container, if necessary.

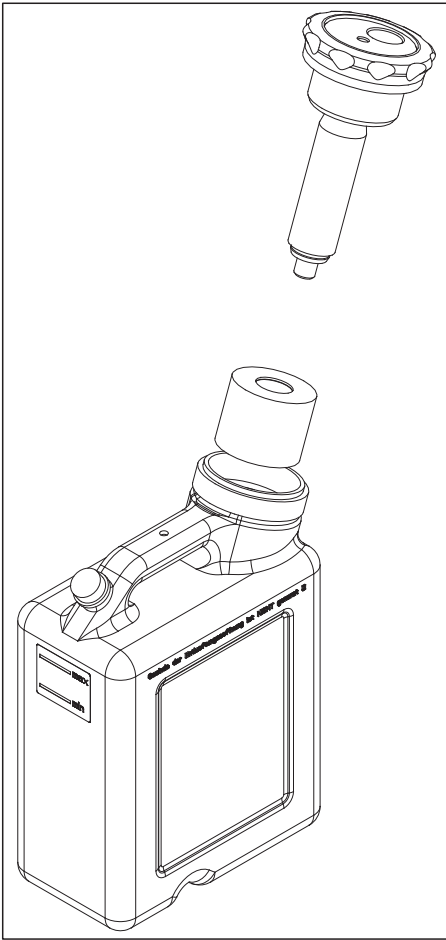

2. Open the tank lid clip (C) and pull the filter system out. Pay attention to any remainder liquid.
3. Drain two-thirds of the coolant tank.
4. Shake the tank.
5. Drain the coolant tank.

#### NOTE

##### Foaming not permissible!

If any cleaning agents are used, this will create foam, which is not permitted.

> Do not use any cleaning agents.

6. Shake the contents of a bottle of DentaLub into the tank.
7. Fill the tank with water up to the mark (max, D) (approx. 10 liters).
8. Place the filter system in the tank.
9. Lock the tank with the tank lid clip.
10. Connect the tank inlet hose (A) with the large diameter as well as the thin coolant supply hose (B) again to the tank system.

## 7.11 Replacing the main fuse

### **WARNING**

#### **Electric shock**

Disconnect the power plug at the unit end before replacing the fuses.

### **NOTE**

#### **Fuse type**

The main fuses F1 and F2 are of the T3.15A 500V type. They are available under the REF 6361336.

➤ Use only fuses of the same type in the fuse holder!

- ✓ The power plug must be disconnected.
- 1. Use a screwdriver to carefully pry off the cover of the fuses on the back side of the unit.
- 2. Pull out the fuse holder.
- 3. Replace the defective fuses.
- 4. Reinsert the fuse holder.
- 5. Close the cover.

## 7.12 Error messages and measures

In the event of an error, the machine outputs error messages. Refer to the following table for measures to be taken for the respective error.









Error message	Action
Error in the air circuit of the spindle sealing air.	Please check the compressed air supply (7 bar). If the error persists, contact customer service.
Error in the air circuit of the tool change cylinder.	Please check the compressed air supply (7 bar). If the error persists, contact customer service.
Error in the blast air circuit.	Please check the compressed air supply (7 bar). If the error persists, contact customer service.
Error in the air circuit of the boost valve (pressure increase).	Please check the compressed air supply (7 bar). If the error persists, contact customer service.
The water pump reported an error.	Please check that there is enough water in the tank or that the inlet and outlet are properly connected.
The suction device reported an error.	Please check that the suction device is connected and switched on or, for wet processing, is switched off. Please also check that the plugs are properly connected.
The spindle reported an error.	Please check the state of the tools. If the tools are heavily worn out, replace them and re-start the process.
Internal software error.	Please re-start the machine. If the error persists, contact customer service.
No system pressure was detected.	Please check the compressed air supply (7 bar). If the error persists, contact customer service.
Unspecified communication error. Please try again.	Unspecified communication error. Please try again. If the error persists, contact customer service.
Time-out occurred during order processing !	Unspecified communication error. Please try again. If the error persists, contact customer service.
The suction device reported an error.	Please check that the suction device is connected and switched on and check that the plug is properly connected.
The suction device reported an error.	Please check that the suction device is switched off.
No valid calibration data available.	Please contact customer service.
The door lock reported an error.	Please check that the door is properly locked. If the error persists, contact customer service.
The cover of the instrument tray cannot be closed.	Please check that the lock of the magazine is closed.
The chuck cannot be opened.	Please check the compressed air supply (7 bar). If the error persists, contact customer service.
The chuck cannot be closed.	Please check the compressed air supply (7 bar). If the error persists, contact customer service.
No tool detected.	Please check that each tool is connected correctly.
The tool could not be removed and is still secure in the chuck.	Please try again to change the tool or change the tool manually using the spindle maintenance in the machine configuration. Clean the chuck using the accompanying maintenance kit.
The tool sensor reported an error.	Please clean the sensor and then manually actuate it a few times. If the error persists, contact customer service.













Error message	Action
An error has occurred during the reference run of the machine.	Please re-start the machine. If the error persists, contact customer service.
The B-axis is in an unknown starting position.	Please manually adjust the workpiece holder so that it is parallel with the support arm and ensure that the clamping screws of the holder are facing upwards.
The calibration data exceeds the tolerance values.	Please contact customer service.
An error occurred during a process.	Please re-start the process. If the error persists, contact customer service.

## 7.13 Consumables:

The following consumables and spare parts are available for the inLab MC X5.

- Section bellows (REF 6496686)
- DENTATEC 1000ml (REF 5809640)
- DentaLub (REF 6597228)
- Coolant tank filter (REF 6387067)
- Sponge insert for door (REF 6526839)
- Tools (see table)

Tool	Image	Ring color	REF
Diamond 1.4		White	6478015
Diamond 1.2		White	6478023
Diamond 2.2		White	6478007
Diamond 0.6		White	6542232
Bur 0.5 PMMA		Red	6478114
Bur 1.0 PMMA		Red	6478106
Bur 2.5 PMMA		Red	6478098
Bur 0.5 ZrO2		Yellow	6478056
Bur 1.0 ZrO2		Yellow	6478049

Tool	Image	Ring color	REF
Bur 2.5 ZrO2		Yellow	6478031
Bur 0.5 ZrO2 DC		Yellow	6572957
Bur 1.0 ZrO2 DC		Yellow	6572940
Bur 2.5 ZrO2 DC		Yellow	6572932
Bur 0.5 Composite (for software version inLab CAM SW ≤ 15.2 only)		Blue	6478171
Bur 0.5 Composite (coated) (for software version inLab CAM SW ≥ 16.0 only)		Blue	6559368
Bur 1.0 Composite (coated) (for software version inLab CAM SW ≥ 15.0 only)		Blue	6551696
Bur 2.5 Composite (coated) (for software version inLab CAM SW ≥ 15.0 only)		Blue	6551688
Bur 0.5 sintering metal		Gray	6478080
Bur 1.0 sintering metal		Gray	6478072
Bur 2.5 sintering metal		Gray	6478064
Bur 1.0 metal		Green	6606292
Bur 2.0 metal		Green	6606243

## 8 Dismantling and disposal

### 8.1 Dismantling and reinstallation

For dismantling and re-installing the device, proceed according to the instructions in chapter Transportation and installation [→ 27] so as to ensure the proper functioning and stability of the unit.

### 8.2 Disposal

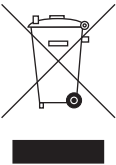

In accordance with Directive 2012/19/EU and national disposal regulations regarding old electrical and electronic devices, please be advised that such items must be disposed of in a special way within the European Union (EU). These regulations require the environmentally friendly recycling/disposal of old electrical and electronic devices. Such items must not be disposed of as domestic refuse. This has been expressed using the icon of the “crossed out trash can”.

#### Disposal procedure

We feel responsible for our products from the first idea to their disposal. For this reason, we give you an option to return our old electronic and electrical devices.

If you wish to dispose of your devices, please proceed as follows:

#### In Germany

To initiate return of the electrical device, please send a disposal request to enretec GmbH. You have the following options here:

- Use the “Returning an electrical device” button under the “eom” menu item on the enretec GmbH homepage ([www.enretec.de](http://www.enretec.de)).
- Alternatively, you can also contact enretec GmbH directly.

enretec GmbH  
Kanalstraße 17  
16727 Velten  
Tel.: +49 3304 3919-500  
E-mail: [eom@enretec.de](mailto:eom@enretec.de)

In accordance with the national disposal regulations regarding old electrical and electronic devices (ElektroG), as the manufacturer, we assume the costs for disposing of the electrical and electronic devices in question. Disassembly, transport and packaging costs shall be borne by the owner/operator.

Prior to disassembly/disposal of the product, it must be fully prepared (cleaned/disinfected/sterilized).

If your unit is not permanently installed, it will be collected from the practice. If it is permanently installed, it will be picked up curbside at your address by appointment.

#### Other countries

For country-specific information on disposal, contact your local dental dealers.

# Index

## A

Application, 12

## B

Building installation, 19

## C

Care, cleaning, and disinfecting agents, 68

CE mark, 11

Coolant tank

    Change the coolant, 80

    Odor formation, 80

Customer service center, 7

## D

Dimensions, 18

Disinfectant, 70

Disposal of old electrical and electronic devices, 103

## E

enretec GmbH, 103

## F

Filter

    Changing, 79

Fuse

    Fuse type, 99

    Replacement, 99

## H

Humidity range, 18

## I

Installing the unit

    automatic, 45

    manual, 46

    removal, 46

Intended use, 12

## M

Maintenance, 9, 19

    Regulations, 68

Manufacturer's address, 7

## N

Nominal current, 18

## O

Operating mode, 18

## P

Packaging, 27

Packing, 33

Product safety, 20

Protection class, 18

## R

Rated line voltage, 18

Repair, 19

## S

Safety instructions, 7

Scope of supply, 12

Service, 9

## T

Temperature range, 18

Type designation, 18

## U

Unpacking, 27

## V

Ventilation slots, 26

## W

Water, 18

Weight, 18





---

We reserve the right to make any alterations which may be required due to technical improvements.

© Sirona Dental Systems GmbH  
D3608.201.01.09.02 08.2018

Sprache: englisch  
Ä.-Nr.: 125 732

Printed in Germany

---

**Sirona Dental Systems GmbH**



Fabrikstr. 31  
64625 Bensheim  
Germany  
[www.dentsplysirona.com](http://www.dentsplysirona.com)

Order No **64 78 759 D3608**