

ULTRASONIC HEAT/ COOLING ENERGY METER

QALCOSONIC E3

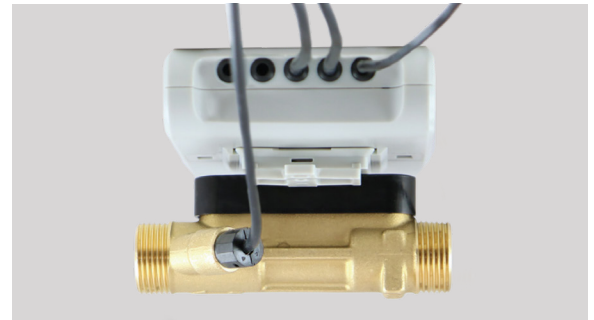

APPLICATION

QALCOSONIC E3 is designed for commercial accounting of heating and cooling energy when heating media is water and is used in centrally heated objects: residential houses or heat supply objects.

- Static liquid metering using ultrasonic technology
- High accuracy
- For residential and commercial use
- Heating and Cooling
- MID DN15 – DN100

SPECIAL FEATURES

- Flexible meter configuration. Meter is delivered in user configuration mode with possibility to configure meter parameters and features as: units, mounting position, pulse inputs/outputs, communication ON/OFF and other meter parameters
- Dual communication module options (RF/MBUS, MBUS/MBUS, LoRa/MBUS...)

- Accuracy class 2
- Nominal flow 0.6 / 1.0 / 1.5 / 2.5 / 3.5 / 6.0 / 10.0 / 15.0 / 25.0 / 40.0 / 60.0 m³/h
- Dynamic range up to $q_p/q_i = R 100/250$
- No straight sections required for DN15 – DN50
- No measurement of air
- Ambient class B
- Protection class IP 65/67/68
- Nominal pressure PN16/25 bar
- Pressure P25/63
- Temperature measurement Pt500, 0 °C ... 180 °C
- Temperature of conveying liquid: 5 °C ... 130 °C
- Metering archive
- Battery lifetime > 15+1 years
- Power supply options: Battery/External
- Optional communication modules
- Mounting in any installation position
- RF and Mbus on-board (by request)
- Tariff functions

APPROVALS

- MID approval certificate
- EN1434
- 2014/32/EU

AMR INTERFACES, OPTIONAL

- W-Mbus 868 MHz (only on-board)
- MBus
- ModBus
- BACnet
- LoRa

MEASURING ACCURACY CLASS 2

OPTICAL INTERFACE

Integrated into the front panel of calculator. It is designed for data reading via M-bus protocol and parameterization of the meter

RADIO INTERFACE

The internal radio provides data reading via WMBUS telegram: S1, T1 OMS mode, LoRa

WMBUS telegram:

- Current total Energy
- Current flow
- Current date and time
- Accounting date information
- Error date

HOURLY, DAILY AND MONTHLY PARAMETER VALUES

- Integrated energy
- Integrated cooling energy
- Integrated energy of tariff
- Integrated volume of liquid
- Integrated pulse value in pulse input 1/2
- Maximum thermal power value for heating/cooling and date
- Maximum value of flow/return temperature of heat conveying liquid and date
- Minimum value of flow/return temperature of heat conveying liquid and date
- Minimum value of temperature difference and date
- Average value of flow/return temperature of heat conveying liquid
- Operating time without an error
- Total error code
- Time when the flow rate exceeded $1.2 q_s$
- Time when the flow rate was less than q_i

DATA LOGGER – HISTORY VALUES

- Every hour, day and month values of the measured parameters are stored in internal memory
- All data from archive can be read by means of the remote reading
- In addition data logger records of monthly parameters can be seen on the display
- Hours for archive records: 1480 h
- Days for archive records: 1130 days
- Months for archive records: 36 months
- Archive data storage time: at least 36 months

Time of storage of all measured integral data, also without power supply to the electronic unit: at least 15 years

LCD INDICATOR:

- The device is equipped with 8-digits LCD (Liquid Crystal Display) with special symbols to display parameters, measurement units and operation modes
- The following information can be displayed:
 - integral and instantaneous measured parameters
 - archive data and set day data
 - device configuration information
- Programmable LCD displaying parameters

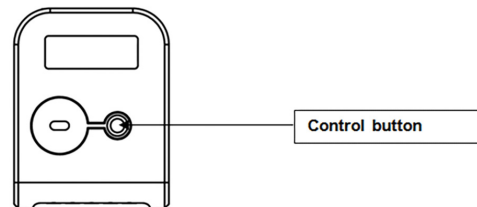

POWER SUPPLY:

Power supply (one of following depending on meter configuration):

- AA battery 3,6 V 2,4 Ah (Li-SOCI2) battery, operation time at least 15+1 years
- 12.42 V DC or 12...36 V 50/60Hz AC external power supply, used current 10 mA and back up battery AA 3,6 V (Li-SOCI2)
- 230 V (+ 10% - 30%) 50 / 60Hz AC power supply, current consumption is not more than 10 mA

TECHNICAL DATA:

Flow rate sensor	q_p [m ³ /h]	0.6 / 1.0 / 1.5 / 2.5 / 3.5 / 6.0 / 10 / 15 / 25 / 40 / 60
	R q_p/q_i [m ³ /h]	100/250
	Resolution of flow-rate indicators:	00000,001 m ³
Technical data	LCD Display	8-digit
	Protection class [IP]	IP65/67/68
	Ambient class	Class B / EN 14 154
	Ambient temperature	+5 °C...+65 °C
	Units (selectable by the user when installing):	kWh; MWh; GJ; Gcal; m ³
	Resolution of energy indicators (selectable by the user when installing):	000000,01 kWh, 0000000,1 kWh, 00000001 kWh, 00000,001 MWh (Gcal or GJ) 000000,01 MWh (Gcal or GJ)
	Installation position	all installation positions (vertical, horizontal, rising pipe, down pipe)
	Nominal pressure [bar]	PN16/25 bar
	Pressure loss	0,63 / (0,25) bar
	Battery lifetime	15+1 years
	Flow sensor cable length	1,2 m (2,5 m or 5 m – special order)
	Temperature sensor Pt500, two-wire connection, cable length	Up to 10 m
	Temperature measurement range	0 °C – 90 °C, 0 °C – 130 °C
Mounting of calculator	Mounting on standard DIN-rail or on the wall	
	Number of configurable pulse inputs/ outputs	2 or no (to be specified when ordering), OB – in the operating mode; OD – in the test mode

PULSE VALUE IN THE OPERATING MODE:

- When the output is configured for energy, the value of its pulses can be selected from the list (depending on the rated flow q_p and energy measurement units):

Energy pulse value, when units are "kWh" or "MWh"	0,00001 - 10 000 MWh/pulse
Energy pulse value, when units are "GJ"	0,0001 - 10 000 GJ/pulse
Energy pulse value, when units are "Gcal"	0,0001 - 1 000 Gcal/pulse

- When the output is configured for water quantity, the value of its pulses can be selected from the list (depending on the permanent flow q_p):

Water volume pulse value, m ³ /pulse	0,001 - 10 m ³ /pulse
---	----------------------------------

- If the meter is ordered with the pulse input-output device, then a permanently connected 1.5 m length cable is fitted in the meter for connecting the inputs-outputs

Permanent flow rate q_p , m^3/h	Upper flow-rate q_s , m^3/h	Lower flow-rate q_r , m^3/h	Threshold value of flow rate, m^3/h	Length of the flow sensor L, mm	Pressure losses at q_p , kPa	Joining to the pipeline (Thread – G, flange – DN)
0.6	1.2	0.006	0.003	110	7	G3/4"
0.6	1.2	0.006	0.003	190	0.9	G1" or DN20
1	2	0.01	0.005	110	11.3	G3/4"
1	2	0.01	0.005	190	2.5	G1" or DN20
1.5	3	0.006	0.003	110; 165	17.1	G3/4"
1.5	3	0.006	0.003	190	5.8	G1" or DN20
1.5	3	0.015	0.003	110; 165	17.1	G3/4"
1.5	3	0.015	0.003	190	5.8	G1" or DN20
1.5	3	0.015	0.005	130	7.2	G1"
2.5	5	0.01	0.005	130	19.8	G1"
2.5	5	0.01	0.005	190	9.4	G1" or DN20
2.5	5	0.025	0.005	130	19.8	G1"
2.5	5	0.025	0.005	190	9.4	G1" or DN20
3.5	7	0.035	0.017	260	4	G1 1/4", G1 1/2", DN25 or DN32
3.5	7	0.014	0.007	260	9	G1 1/4", G1 1/2", DN25 or DN32
6	12	0.024	0.012	260	10	G1 1/4", G1 1/2", DN25 or DN32
6	12	0.06	0.012	260	10	G1 1/4", G1 1/2", DN25 or DN32
10	20	0.04	0.02	300	18	G2" or DN40
10	20	0.1	0.02	300	18	G2" or DN40
15	30	0.06	0.03	270	12	DN50
15	30	0.15	0.03	270	12	DN50
25	50	0.1	0.05	300	20	DN65
25	50	0.25	0.05	300	20	DN65
40	80	0.16	0.08	300	18	DN80
40	80	0.4	0.08	300	18	DN80
60	120	0.24	0.12	360	18	DN100
60	120	0.6	0.12	360	18	DN100

SIZE AND DIMENSIONS

- Electronic unit: 116 mm x 32.5 mm x 90 mm

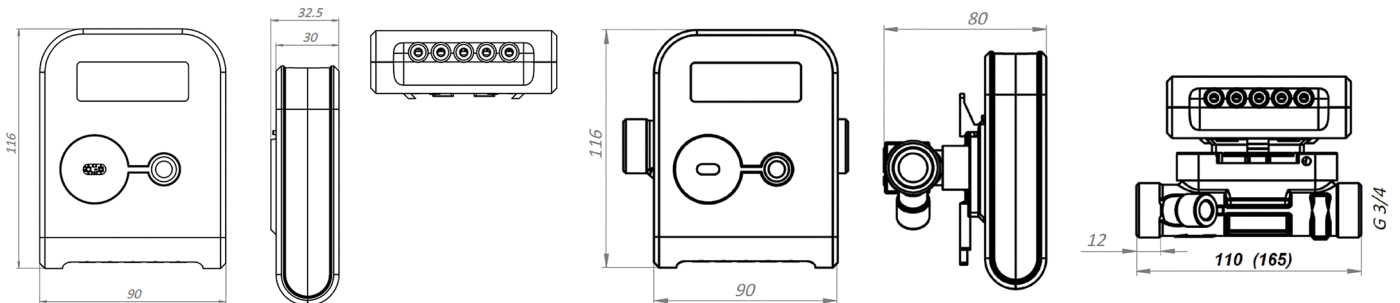

- Example – flow sensor 1.6/2.5 m^3/h , Threaded end connections G3/4", mounting length L=110 mm

DN [mm]	15	20	25	40	50	65	80	100
L [mm]	110/165	130/190	260	300	270	300	300	360
H [mm]	80	84/112	131/137	118/150	159	185	200	225
G/Flange DN	G3/4"	G1" or DN20	G1 1/4" or DN25	G2" or DN40	DN50	DN65	DN80	DN100