

REAR LOADING CONTAINERS – 2 WHEELS

C120

120 L
Capacity

48 Kg
Nominal load

200 mm
Wheels diameter



TECHNICAL SPECIFICATIONS

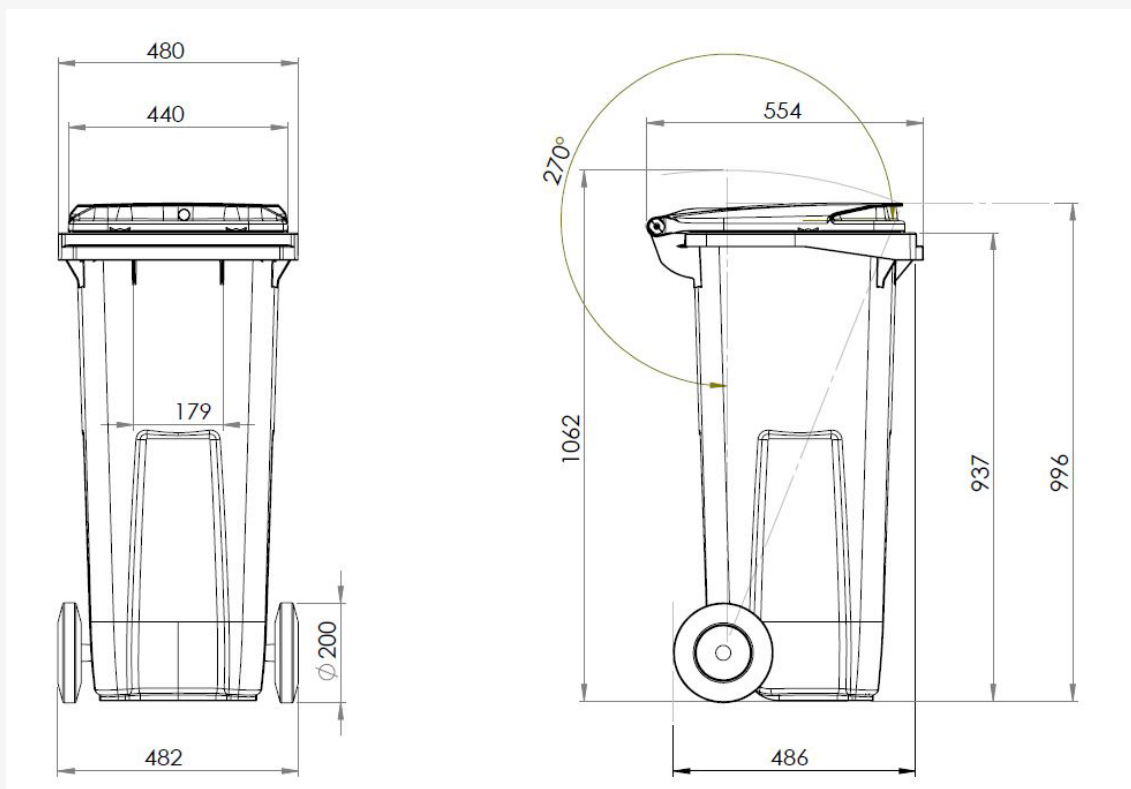

Note: These dimensions are subject to the tolerances given in EN-840-1:2020

K674481E / 10.01.2020 / REV 0.0

REAR LOADING CONTAINERS – 2 WHEELS

C120

FEATURES

- The design of the rear-loading CONTENÜR containers are focused on the ergonomics and aesthetics of all parts.
- Manufactured using injection moulded solid-coloured high-density polythene, stabilised against the combined effects of water and UV radiation.
- It is manufactured using environmentally-friendly, recyclable materials.
- No heavy metals in the pigments used.

STANDARDS

- CE Marking with sound power level indicated in accordance with European Directive 2000/14/EC. 79 db.
- Product Approval Certificate awarded by TÜV Product Service GmbH in accordance with European Standard EN 840-1: 2020.

EQUIPMENT AND ACCESSORIES

- The containers are designed to facilitate stacking, optimising logistics, which contributes to reduced CO2 emissions when transporting them.
- Customised containers for each type of waste collection: paper and cardboard, glass, plastics, glass, organic waste... .
- DIN or AFNOR standard lifting systems.
- Integrated sound-proofing system in the lid.
- Recess for the installation of electronic chips.
- Wheels designed to prevent dirt from sticking to the wheel and to aid cleaning.
- Possibility of customising body and lid of the container with shields, logos, etc. using the thermal transfer graphic system .
- Customisation of body with thermal transfer graphic, maximum size: 260 x 260 mm
- Customisation of lid with thermal transfer graphic, area 230 x 45 mm
- Customisation of lid with an embossed logo, maximum size: 340 x 220 mm.



C80



C120



C140



C180



C240



C360

REAR LOADING CONTAINERS – 2 WHEELS

C120

CUSTOMISATION

Can be equipped with a range of accessories providing real solutions to every requirement ...

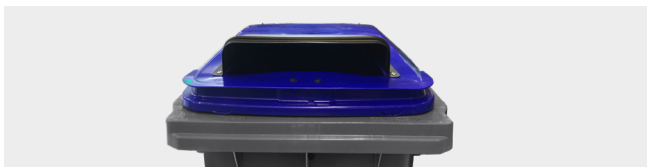

PAPER SLOT WITH COWL



LID IN LID



MIXED RECYCLING
BRUSH OPENING



MIXED RECYCLING



SIDE HANDLE



CUSTOMISATION
BY THERMAL TRANSFER
GRAPHIC



PEDAL



RED DOME LOCK
(gravity/non gravity)

STANDARD COLOURS



TO SEE PRIMIUM COLOURS PLEASE CHECK
WWW.CONTENUR.CO.UK