

Consort

Artistic in science



21-03

Product catalogue

Table of contents

● Electrochemical Measurement

C3000 series	2
C3050 - Bio-electronic analysers	4
C3210 - C3230 - Multi-parameter analysers	6
C6000 series	8
DIS-1 - Data acquisition software	10
C1000 series	11
C1010 - C1020 - Multi-parameter analysers	12
LabArt C51 series	13
D230 system - Multi-parameter data-logger	15
Measurement tips	17

● Controllers

R3600 series	19
DIS-2 - Data acquisition software	21

● Electrodes

Electrodes	23
Electrode application guide - pH and ORP	24
pH electrodes	25
Special electrodes	25
ORP/DO electrodes	26
Conductivity electrodes	27
Temperature Compensator	27
Ion selective electrodes	28
Solutions - pH - ORP - Conductivity - Ion	29
AP414 - Thermal printer	30
SH300 - Electrode holder	30
pH Measurement FAQ	31

● Electrophoresis Power Supplies!

EV2000 series	33
EV3000 series 300V to 6000V	35

● Horizontal Units

EHS3000 series	38
EHS3xxx series - Horizontal units	39
EHS3100 - Mini horizontal unit	40
EHS3200 - Mini horizontal unit	41
EHS3300/EHS3350 - Mini horizontal unit	42
EHS3400 - Wide horizontal unit	43
EHS3410 - Long horizontal unit	44
EHS3500 - Wide long horizontal unit	45
EHS3600 - Wide horizontal unit	46
EHS3610/EHS3660 - Maxi horizontal unit	47
EHS3620 - Maxi horizontal unit	48
About Horizontal Electrophoresis	49
EHS1000 - Horizontal unit	49
EHS1050 - Mini rapid horizontal unit	50
EHS1100 - Mini horizontal unit	51
EHS1200 - Midi horizontal unit	52
EHS1300 - Midi-plus horizontal unit	53
EHS1400 - Maxi horizontal unit	54
EHS1500 - Maxi-plus horizontal unit	55
EIEF1100 - Isoelectric focusing	56
About Electrophoresis Power Supplies	57

● Vertical Units

EVS3xxx series - Vertical units	59
EVS3100 - Mini vertical unit	60
EVS3200 - Wide vertical unit	61
EVS3300 - Maxi vertical unit	62
EVS3100-BLOT	63
EVS3300-BLOT	64
ESDB3000 series	65
About Vertical Electrophoresis	66
EVS1000 series - Vertical units	66
EVS1100 - Mini vertical unit	67
EVS1200 - Mini-wide vertical unit	68
EVS1300 - Maxi vertical unit	69
EVS1x00-MULTI	70
EVS1x00-BLOT	71
ESDB1x00 series - Semi-dry blotters	72
ESEQ1100/ESEQ1200 - Sequencing system	73

● Clinical Electrophoresis

EHCA1100 - Cellulose acetate system	75
EHCA1200 - Cellogel cellulose acetate system	76
EHCA1200 kits	77
EHCA1200 Cellogel	79
Universal Densitometer	81

● UV Lamps

UVL 3000 series - UV lamps with filter	83
CN-15/CN-6 Darkroom	84
BLoOK	85
UV Accessories	86

● Important information

Technical data	87
General Terms	89

Electrochemical Measurement



- Gold Plated BNC
- Multichannel
- Pre-programmed standards
pH: 1.68, 2.00, 4.00, 4.01, 6.87, 6.99, 9.18, 9.21, 10.01, 12.00, 12.45 (at 25°C) + 5 user editable
Conductivity: 1413 µS/cm, 12.88 mS/cm, 111.8 mS/cm (at 25°C) + 3 user editable
- No interference between electrodes
- Stability algorithm with intuitive indicator
- Hold function
- Selectable resolution
- Range lock
- Capacitive compensation
- Galvanic isolated USB interface
- Ethernet connection available
- High Accuracy
- Free software and firmware updates



AP414

SH300

The C3000 series are all full-parameter multi-channel instruments. 2 channels up to 8 channels with each channel having it's own dedicated measurement hardware without interference between the channels. All values can be displayed simultaneously on the screen.

Specifications depending on model

Measurement Channels	2 to 8 (max 2 EC channels)
Temperature Channels	2 (C3062) and 6 (C3040)
pH	-10.000...+20.000 pH
mV	±2000.0 mV
Ion	0.01 ng/l...100 g/l
Conductivity	0...2000 mS/cm
Resistivity	0...200 MΩ.cm
Salinity	0.0...70.0
TDS	0...100.0 g/l
Dissolved oxygen	0...60.00 mg/l 0...600%
Air pressure	600...1300 hPa
Temperature	-30.0...+130.0°C
Warranty	36 months
Made in Belgium	

Code	Description
C3040	6 channel pH/Ion/conductivity/DO/ISE meter
C3062	8 channel pH/Ion/conductivity/DO/ISE meter



Code	Description	Content
C30xxP	pH meter kit, glass electrode	meter + pH electrode SP20T + 2x50ml pH buffers + 50ml electrolyte
C30xxPE	pH meter kit, epoxy electrode	meter + pH electrode SP10T + 2x50ml pH buffers + 50ml electrolyte
C30xxK	EC meter kit, glass electrode	meter + EC electrode SK20T + 50ml EC standard
C30xxKE	EC meter kit, epoxy electrode	meter + EC electrode SK10T + 50ml EC standard
C30xxPK	pH/EC meter kit, glass electrodes	meter + pH electrode SP20T + EC electrode SK20T + 2x50ml pH buffers + 50ml electrolyte + 50ml EC standard
C30xxPKE	pH/EC meter kit, epoxy electrodes	meter + pH electrode SP10T + EC electrode SK10T + 2x50ml pH buffers + 50ml electrolyte + 50ml EC standard
C30xxZ	Oxygen meter kit	meter + DO electrode SZ10T
C30xxT	Complete meter kit, glass electrodes (DO epoxy)	meter + pH electrode SP20T + EC electrode SK20T + 2x50ml pH buffers + 50ml electrolyte + 50ml EC standard + DO electrode SZ10T
C30xxTE	Complete meter kit, epoxy electrode	meter + pH electrode SP10T + EC electrode SK10T + 2x50ml pH buffers + 50ml electrolyte + 50ml EC standard + DO electrode SZ10T
C30xxX	Meter kit without electrodes	meter + 2x50ml pH buffers + 50ml electrolyte + 50ml EC standard
AP414	Serial printer	
SH300	Flexible electrode holder (optional)	

Kits are available for each meter. Replace xx with correct meter number. F.i. C3040P, C3060T, etc...

Specifications

pH	Range	-10.000...+20.000 pH
	Resolution	0.001 pH
	Accuracy	0.1% ± 1 digit
	Calibration	1...5 points
	Buffers	11 pre-programmed 5 user specified
	Temperature compensation	-5.0...+105.0°C
	ISO-pH	6.000...8.000 pH
	Slope	80.0...120.0%
	Zero point (Eo)	±999.0 mV
	Selectable Resolution	✓
	mV	Range
Resolution		0.1 mV
Accuracy		0.1% ± 1 digit
Calibration		1 point
Selectable Resolution		✓
CONDUCTIVITY	Range (cc dependent)	0...2000 mS/cm
	Resolution (cc dependent)	0.001 µS/cm
	Accuracy	0.5% f.s. of range
	Calibration	1...3 points
	Standards	3 pre-programmed 3 user specified
	Cell constant (cc)	0.07...13 cm-1
	Temperature compensation	-5...+105°C or off
	Reference temperature	20°, 25°C
	Temperature coefficient	natural waters (EN27888)
	Range lock	✓
	Capacitive compensation	✓
RESISTIVITY	Range	0...200 MΩ.cm
	Resolution	1 Ω.cm
SALINITY	Range	0.0...70.0
	Reference temperature	15°C
TDS	Range	0...100.0 g/l
	Resolution	0.01 mg/l
DISSOLVED OXYGEN	Range	0...60.00mg/l
	Resolution	0.01 mg/l
	Accuracy	1% ± 1 digit
	Calibration	1 point
	Temperature compensation	0...50°C
	Salinity compensation	0...40
	Air pressure compensation	600...1300 hPa
Selectable Resolution	✓	

TEMPERATURE	Range	-30.0...+130.0°C
	Resolution	0.1°C
	Accuracy	0.1°C
ION	Range	0.01 ng/l...100 g/l
	Resolution	3 digits
	Accuracy	0.5% ± 1 digit
AIR PRESSURE	Range	600...1300 hPa
	Calibration	1 point
CHANNELS	Measurement	6
	Temperature	6
INPUTS	Measurement	6 BNC, 10 ¹² Ω
	Temperature	6x2 banana, for Pt1000
CALIBRATION	Reminder	0...999 h
	GLP	✓
DISPLAY	LCD	240x64 pixels
	White back-light	✓
	Hold function	✓
	Selectable resolution	✓
	Real time clock	✓
	Built-in help	✓
	Languages	English Dutch French German
COMMUNICATION	Interface with computer	USB/RS232
	Baud rate	1200...115200 b/s
	Printer	✓
DATA-LOGGING	Data sets	12000 + °C/date/time
	Modes	all
	Manual or timed	✓
	Interval	1...9999 s
SECURITY	Password protection	✓
AMBIENT CONDITIONS	Temperature	0...40°C
	Humidity	0...95%, non condensing
POWER SUPPLY	Mains	100...240 VAC, 50/60 Hz
	Low voltage	9...15 VDC
DIMENSIONS	WxDxH	26x18x9 cm
WEIGHT	Meter	1 kg

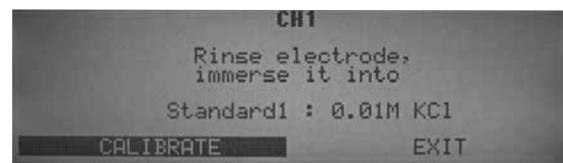

- Measurement Channels 3 (conductivity: 2)
- Temperature Channels 3
- pH -10.000...+20.000 pH
- mV ±2000.0 mV
- Conductivity 0...2000 mS/cm
- Resistivity 0...200 MΩ.cm
- Salinity 0.0...70.0
- TDS 0...100.0 g/l
- Temperature -30.0...+130.0°C
- μW 0...400000 μW
- rH₂ 0.00...42.00 rH₂
- Warranty 36 months
- Made in Belgium



C3050 is an instrument capable of measuring all parameters according to Vincent's method. All parameters can be measured at once and shown on the wide display.

This instrument is built with the same quality as the instruments in the whole C3000 series. As such, it has the same features as the other versions. All 3 gold plated BNC connectors each accept different electrodes of which 2 connectors also accept conductivity electrodes. There is no interference between the channels when measuring pH/ORP/Ion and conductivity electrodes in the same solution.

Besides the pre-programmed pH buffers and EC standards, you can also add your own buffer and standard tables. Not just a certain value at a certain temperature but the complete temperature related table of your specific buffer. Add up to 5 pH buffers and 3 EC standards of your own choice and use them as if they are built-in.

Two temperature inputs are independent from measurement channels. ATC for each channel can be selected from any of the temperature inputs. The device can be connected to a PC and completely controlled via USB/RS232. Both software and communication protocol can be downloaded from our website.

Multichannel up to 3 measurements can be performed at the same time and simultaneously or individually shown on the display. All parameters according to Vincent's method can be shown on the display. Each channel can measure 2 times per second.

No interference between pH/ORP and conductivity electrodes in the same solution

Custom calibration tables allow the user to add complete buffer/standard-temperature relation tables. With this feature the built-in tables can be extended with your own tables. Tables can be entered via a device menu or uploaded from a PC.

Direct rH₂ and μW measurement when using a pH, ORP and EC electrode. All 5 parameters can be displayed simultaneously.

Wide Display shows all channels at the same time including temperature and date/time.

Stability indicator ensures visualisation when the measurement has stabilised.

Stability algorithm ensures stable readings with ability to detect fast changes.

Hold function allows to freeze the display

Selectable resolution for more stable readings on mV and pH.

Range lock for conductivity measurements.

Capacitive compensation eliminates the capacitive component of the electrode and cable when measuring low conductivities.

Galvanic isolated USB interface eliminates ground loop effects when connected to a PC.

Pre-programmed standards

pH: 1.68, 2.00, 4.00, 4.01, 6.87, 6.99, 9.18, 9.21, 10.01, 12.00, 12.45 (at 25°C)
 Conductivity: 1413 μS/cm, 12.88 mS/cm, 111.8 mS/cm (at 25°C)

Free software and firmware updates downloadable from www.consort.be

Specifications

pH	Range	-10...+20 pH	
	Resolution	0.001 pH	
	Accuracy	0.1% ± 1 digit	
	Calibration	1...5 points	
	Buffers	11 pre-programmed 5 user specified	
	Temperature compensation	-5...+105°C	
	ISO-pH	6...8 pH	
	Slope	80...120%	
	Zero point (Eo)	±999 mV	
mV	Range	±2000 mV	
	Resolution	0.1 mV	
	Accuracy	0.1% ± 1 digit	
	Calibration	1 point	
rH₂	Range	0...42 rH ₂	
	Resolution	0.01 rH ₂	
CONDUCTIVITY	Accuracy	0.1% ± 1 digit	
	Range (cc dependent)	0...2000 mS/cm	
	Resolution (cc dependent)	0.001 µS/cm	
	Accuracy	0.5% f.s. of range	
	Calibration	1...3 points	
	Standards	3 pre-programmed 3 user specified	
	Cell constant (cc)	0.07...13 cm ⁻¹	
	Temperature compensation	-5...+105°C	
	Reference temperature	20°...40°C	
	Temperature coefficient	natural waters (EN27888)	
	Range lock	✓	
	Capacitive compensation	✓	
	RESISTIVITY	Range	0...200 MΩ.cm
		Resolution	1 Ω.cm
SALINITY	Range	0...70	
	Reference temperature	15°C	
TDS	Range	0...100 g/l	
	Resolution	0.01 mg/l	
µW	Range	0...400000 µW	

TEMPERATURE	Range	-30...+130°C
	Resolution	0.1°C
	Accuracy	0.1°C
	Calibration	1 point
CHANNELS	Measurement	3 (conductivity: 2)
	Temperature	3
INPUTS	Measurement	3 BNC, 10 ¹² Ω
	Temperature	3x2 banana, for Pt1000
CALIBRATION	Reminder	0...999 h
	GLP	✓
DISPLAY	LCD	240x64 pixels
	White back-light	✓
	Hold function	✓
	Selectable resolution	✓
	Real time clock	✓
COMMUNICA-TION	Interface with computer	USB/RS232 or Ethernet/RS232
	Baud rate	1200...115200 b/s
	Printer	✓
DATA-LOGGING	Data sets	12000 + °C/date/time
	Modes	all
	Manual or timed	✓
	Interval	1...9999 s
SECURITY	Password protection	✓
AMBIENT CONDITIONS	Temperature	0...40°C
	Humidity	0...95%, non condensing
POWER SUPPLY	Mains	100...240 VAC, 50/60 Hz
	Low voltage	9...15 VDC
DIMENSIONS	WxDxH	26x18x9 cm
WEIGHT	Meter	1 kg



Ordering codes

Code	Description
C3050	Bio-electronic meter (USB version) + USB cable
C3051	Bio-electronic meter (Ethernet version) + UTP cable
C3050T	Meter kit complete: meter + pH/ORP electrode SP35B + conductivity electrode SK20T+ 2x50 ml buffers (pH 4 and 7) + 50 ml conductivity standard (0.01 M KCl) + 50 ml electrolyte (3M KCl) + 50 ml redox standard (358 mV) + flexible electrode holder SH300
AP414	Serial printer
SH300	Flexible electrode holder (optional)
ADAPT-CAR	Car adaptor, 12 V (optional)

→ Supplied with a mains adaptor (100...240 VAC, EU/US) and USB or UTP cable. Add -UK for UK plug versions, -CH for Swiss plug versions.

New Edition Improved hardware Compact design

- Gold Plated BNC
- Multichannel
- Pre-programmed standards
 - pH: 11 preprogrammed + 5 user editable
 - Conductivity: 3 preprogrammed + 3 user editable
- No interference between electrodes
- Stability algorithm with intuitive indicator
- Hold function
- Selectable resolution
- Range lock
- Capacitive compensation
- Galvanic isolated USB interface
- High Accuracy
- Free software and firmware updates



SH300

The C3210 and C3230 are all full-parameter multi-channel instruments. 2 channels with each channel having it's own dedicated measurement hardware without interference between the channels. All values can be displayed simultaneously on the screen.

New SZ20T: maintenance free DO probe

Specifications depending on model

Measurement Channels	2
Temperature Channels	2
pH	-2.000...+16.000 pH
mV	±2000.0 mV
Ion	0.01 ng/l...100 g/l (C3230 only)
Conductivity	0...2000 mS/cm
Resistivity	0...200 MΩ.cm
Salinity	0.0...70.0
TDS	0...100.0 g/l
Dissolved oxygen	0...60.00 mg/l 0...600%
Air pressure	600...1300 hPa
Temperature	-5.0...+105.0°C
Warranty	36 months
Made in Belgium	

Code	Description
C3210	2 channel pH/conductivity/DO meter
C3230	2 channel pH/Ion/conductivity/DO meter

Code	Description	Content
C32xxP	pH meter kit, glass electrode	meter + pH electrode SP20T + 2x50ml pH buffers + 50ml electrolyte
C32xxPE	pH meter kit, epoxy electrode	meter + pH electrode SP10T + 2x50ml pH buffers + 50ml electrolyte
C32xxK	EC meter kit, glass electrode	meter + EC electrode SK20T + 50ml EC standard
C32xxKE	EC meter kit, epoxy electrode	meter + EC electrode SK10T + 50ml EC standard
C32xxPK	pH/EC meter kit, glass electrodes	meter + pH electrode SP20T + EC electrode SK20T + 2x50ml pH buffers + 50ml electrolyte + 50ml EC standard
C32xxPKE	pH/EC meter kit, epoxy electrodes	meter + pH electrode SP10T + EC electrode SK10T + 2x50ml pH buffers + 50ml electrolyte + 50ml EC standard
C32xxZ	Oxygen meter kit	meter + DO electrode SZ20T
C32xxT	Complete meter kit, glass electrodes (DO epoxy)	meter + pH electrode SP20T + EC electrode SK20T + 2x50ml pH buffers + 50ml electrolyte + 50ml EC standard + DO electrode SZ20T
C32xxTE	Complete meter kit, epoxy electrode	meter + pH electrode SP10T + EC electrode SK10T + 2x50ml pH buffers + 50ml electrolyte + 50ml EC standard + DO electrode SZ20T
C32xxX	Meter kit without electrodes	meter + 2x50ml pH buffers + 50ml electrolyte + 50ml EC standard
SH300	Flexible electrode holder (optional)	

Kits are available for each meter. Replace **xx** with correct meter number.

● Specifications

pH	Range	-10.000...+20.000 pH
	Resolution	0.001 pH
	Accuracy	0.1% ± 1 digit
	Calibration	1...5 points
	Buffers	11 pre-programmed 5 user specified
	Temperature compensation	-5.0...+105.0°C
	ISO-pH	6.000...8.000 pH
	Slope	80.0...120.0%
	Zero point (Eo)	±999.0 mV
	Selectable Resolution	✓
	mV	Range
Resolution		0.1 mV
Accuracy		0.1% ± 1 digit
Calibration		1 point
Selectable Resolution		✓
CONDUCTIVITY	Range (cc dependent)	0...2000 mS/cm
	Resolution (cc dependent)	0.001 µS/cm
	Accuracy	0.5% f.s. of range
	Calibration	1...3 points
	Standards	3 pre-programmed 3 user specified
	Cell constant (cc)	0.07...13 cm-1
	Temperature compensation	-5...+105°C or off
	Reference temperature	20°, 25°C
	Temperature coefficient	natural waters (EN27888)
	Range lock	✓
	Capacitive compensation	✓
RESISTIVITY	Range	0...200 MΩ.cm
	Resolution	1 Ω.cm
SALINITY	Range	0.0...70.0
	Reference temperature	15°C
TDS	Range	0...100.0 g/l
	Resolution	0.01 mg/l
DISSOLVED OXYGEN	Range	0...60.00mg/l
	Resolution	0.01 mg/l
	Accuracy	1% ± 1 digit
	Calibration	1 point
	Temperature compensation	0...50°C
	Salinity compensation	0...40
	Air pressure compensation	600...1300 hPa
Selectable Resolution	✓	

TEMPERATURE	Range	-30.0...+130.0°C
	Resolution	0.1°C
	Accuracy	0.1°C
	Calibration	1 point
ION (C303x only)	Range	0.01 ng/l...100 g/l
	Resolution	3 digits
	Accuracy	0.5% ± 1 digit
	Calibration	2...5 points + blank
AIR PRESSURE	Range	600...1300 hPa
	Calibration	1 point
CHANNELS	Measurement	2
	Temperature	2
INPUTS	Measurement	2 BNC, 10 ¹² Ω
	Temperature	2x2 banana, for Pt1000
CALIBRATION	Reminder	0...999 h
	GLP	✓
DISPLAY	LCD	240x64 pixels
	White back-light	✓
	Hold function	✓
	Selectable resolution	✓
	Real time clock	✓
	Built-in help	✓
	Languages	English Dutch French German
COMMUNICA-TION	Interface with computer	USB/RS232
	Baud rate	1200...115200 b/s
	Printer	✓
DATA-LOGGING	Data sets	12000 + °C/date/time
	Modes	all
	Manual or timed	✓
	Interval	1...9999 s
SECURITY	Password protection	✓
AMBIENT CONDITIONS	Temperature	0...40°C
	Humidity	0...95%, non condensing
POWER SUPPLY	Mains	100...240 VAC, 50/60 Hz
	Low voltage	9...15 VDC
DIMENSIONS	WxDxH	26x18x9 cm
WEIGHT	Meter	1 kg



- Gold Plated BNC
- Portable
- One input handles all electrodes
- Pre-programmed standards
pH: 1.68, 2.00, 4.00, 4.01, 6.87, 6.99, 9.18, 9.21, 10.01, 12.00, 12.45 (at 25°C) + 5 user editable
Conductivity: 1413 µS/cm, 12.88 mS/cm, 111.8 mS/cm (at 25°C) + 3 user editable
- Stability algorithm with intuitive indicator
- Hold function
- Selectable resolution
- Range lock
- Capacitive compensation
- Galvanic isolated USB interface
- High Accuracy
- Free software and firmware updates



The C6000 series are all full-parameter portable instruments. With the optional CONV_USB RS232 it's possible to convert the USB interface to RS232. Suitable for connecting an AP414 printer to the meter.

Specifications depending on model

Measurement Channels	1
Temperature Channels	1
pH	-2.000...+16.000 pH
mV	±2000.0 mV
Ion	0.01 ng/l...100 g/l
Conductivity	0...2000 mS/cm
Resistivity	0...200 MΩ.cm
Salinity	0.0...70.0
TDS	0...100.0 g/l
Dissolved oxygen	0...60.00 mg/l 0...600%
Air pressure	600...1300 hPa
Temperature	-5.0...+105.0°C
Warranty	36 months
Made in Belgium	

Code	Description
C6010	pH/conductivity/DO meter
C6030	pH/Ion/conductivity/DO meter

Code	Description	Content
C60xxP	pH meter kit, glass electrode	meter + pH electrode SP20T + 2x50ml pH buffers + 50ml electrolyte + carrying case
C60xxPE	pH meter kit, epoxy electrode	meter + pH electrode SP10T + 2x50ml pH buffers + 50ml electrolyte + carrying case
C60xxK	EC meter kit, glass electrode	meter + EC electrode SK20T + 50ml EC standard + carrying case
C60xxKE	EC meter kit, epoxy electrode	meter + EC electrode SK10T + 50ml EC standard + carrying case
C60xxPK	pH/EC meter kit, glass electrodes	meter + pH electrode SP20T + EC electrode SK20T + 2x50ml pH buffers + 50ml electrolyte + 50ml EC standard + carrying case
C60xxPKE	pH/EC meter kit, epoxy electrodes	meter + pH electrode SP10T + EC electrode SK10T + 2x50ml pH buffers + 50ml electrolyte + 50ml EC standard + carrying case
C60xxZ	Oxygen meter kit	meter + DO electrode SZ10T + carrying case
C60xxT	Complete meter kit, glass electrodes (DO epoxy)	meter + pH electrode SP20T + EC electrode SK20T + 2x50ml pH buffers + 50ml electrolyte + 50ml EC standard + DO electrode SZ10T + carrying case
C60xxTE	Complete meter kit, epoxy electrode	meter + pH electrode SP10T + EC electrode SK10T + 2x50ml pH buffers + 50ml electrolyte + 50ml EC standard + DO electrode SZ10T + carrying case
C60xxX	Meter kit without electrodes	meter + 2x50ml pH buffers + 50ml electrolyte + 50ml EC standard + carrying case
CONV_USB RS232	USB device to RS232 converter	
AP414	Serial printer	
SH300	Flexible electrode holder	

Kits are available for each meter. Replace xx with correct meter number. F.i. C6010P, C6030T, etc...

Specifications

pH	Range	-2.000...+16.000 pH
	Resolution	0.001 pH
	Accuracy	0.1% ± 1 digit
	Calibration	1...5 points
	Buffers	11 pre-programmed 5 user specified
	Temperature compensation	-5.0...+105.0°C
	ISO-pH	6.000...8.000 pH
	Slope	80.0...120.0%
	Zero point (Eo)	±999.0 mV
	Selectable Resolution	✓
	mV	Range
Resolution		0.1 mV
Accuracy		0.1% ± 1 digit
Calibration		1 point
Selectable Resolution		✓
CONDUCTIVITY	Range (cc dependent)	0...2000 mS/cm
	Resolution (cc dependent)	0.001 µS/cm
	Accuracy	0.5% f.s. of range
	Calibration	1...3 points
	Standards	3 pre-programmed 3 user specified
	Cell constant (cc)	0.07...13 cm ⁻¹
	Temperature compensation	-5...+105°C
	Reference temperature	20°, 25°C or off
	Temperature coefficient	natural waters (EN27888)
	Range lock	✓
	Capacitive compensation	✓
RESISTIVITY	Range	0...200 MΩ.cm
	Resolution	1 Ω.cm
SALINITY	Range	0.0...70.0
	Reference temperature	15°C
TDS	Range	0...100.0 g/l
	Resolution	0.01 mg/l
DISSOLVED OXYGEN	Range	0...60.00mg/l
	Resolution	0.01 mg/l
	Accuracy	1% ± 1 digit
	Calibration	1 point
	Temperature compensation	0...50°C
	Salinity compensation	0...40
	Air pressure compensation	600...1300 hPa
Selectable Resolution	✓	

TEMPERATURE	Range	-5.0...+105.0°C	
	Resolution	0.1°C	
	Accuracy	0.1°C	
	Calibration	1 point	
ION (C6030 only)	Range	0.01 ng/l...100 g/l	
	Resolution	3 digits	
	Accuracy	0.5% ± 1 digit	
	Calibration	2...5 points + blank	
AIR PRESSURE	Range	600...1300 hPa	
	Calibration	1 point	
CHANNELS	Measurement	1	
	Temperature	1	
INPUTS	Measurement	1 BNC, 10 ¹² Ω	
	Temperature	1x2 banana, for Pt1000	
CALIBRATION	Reminder	0...999 h	
	GLP	✓	
DISPLAY	LCD	128x64 pixels	
	White back-light	✓	
	Hold function	✓	
	Selectable resolution	✓	
	Real time clock	✓	
	Built-in help	✓	
	Languages	English Dutch French German	
	COMMUNICATION	Interface with computer	USB
		Baud rate	1200...115200 b/s
	DATA-LOGGING	Data sets	12000 + °C/date/time
Modes		all	
Manual or timed		✓	
Interval		1...9999 s	
SECURITY	Password protection	✓	
AMBIENT CONDITIONS	Temperature	0...40°C	
	Humidity	0...95%, non condensing	
POWER SUPPLY	Mains	100...240 VAC, 50/60 Hz	
	Low voltage	9...15 VDC	
	Batteries (included)	4x1.2 V, AA, NiMH	
	DIMENSIONS	WxDxH	12x25x5 cm
WEIGHT	Meter	600g	



● Description

This free software package is specially designed to collect, store and manage data from the C3000 series, C6000 series and T8700 series controllers when equipped with a digital interface.

DIS-1 runs under Windows™ 2000 or higher and can be downloaded from www.consort.be

● Highlights

Data acquisition. All measurements of all instruments are processed at the same time, each in its own window. Data is collected on-line at a programmable interval determined by the program (1 s ... 24 h).

Starting By using a program-key, the data-logging will start automatically after opening the program. Data-logging can be stopped or continued at any moment. Data, which is stored in the internal memory of the connected instrument, can also be read and processed.

Table Data is always stored in a table. Comments can be added to each line in a special information column.

Files All data is saved in a user defined file. Just open the file to view, process or print the stored data. The incoming data can be stored immediately in a file. All measurements are saved in CVS format which is easily transferred into spreadsheets.

Graphs are generated using automatic or user defined settings. The number of visible values can be changed at any time. Programmable alarm limits for each graph allow to print a report indicating when limits have been exceeded and it shows statistics about minima, maxima and averages.

Communication port: RS232 or USB

Terminal shows exactly how data is received. It enables the user to check for possible errors in the data transmission.

Settings The style of each window can be set up separately. Choose fonts, colours etc... All settings are stored in a configuration file and automatically recalled when opening the program. Documented printouts will show:

- file name.
- date and time.
- name of the operator.
- name of the company.
- name of the division.
- optional notes by the operator.

Functions are accessible through the menu. Only valid options appear in the menu to eliminate set-up errors. Special buttons, icons and short-keys allow the user to easily access the most useful functions. The contents of each window can be transferred to other programs by using a copy function.

- Gold Plated BNC
- Pre-programmed standards
pH: 1.68, 2.00, 4.00, 4.01, 6.87, 6.99, 9.18, 9.21, 10.01, 12.00, 12.45 (at 25°C)
Conductivity: 1413 $\mu\text{S/cm}$, 12.88 mS/cm , 111.8 mS/cm (at 25°C)
- Stability algorithm with intuitive indicator
- Easy to use
- Ideal for schools and small laboratories
- Large graphical display
- Accuracy at a budget



SH300



SK10T



SP10T



SZ10T

The C1000 series are basic, yet complete and accurate bench-top meters. It can measure all common electrochemical parameters such as pH, ORP, Conductivity and Dissolved Oxygen. C1020 adds a larger conductivity range, Salinity, TDS and measurement storage capability.

Specifications depending on model

pH/MV Channels	1
EC/TDS/SAL/DO Channels	1
Temperature Channels	1
pH	0.00...14.00 pH
mV	± 1000 mV
Conductivity	0...100 mS/cm 0...1000 mS/cm
Salinity	0.0...70.0
TDS	0...100 g/l
Dissolved oxygen	0.00...20.00 mg 0...200%
Temperature	0.0...+100.0°C
Warranty	36 months
Made in Belgium	

Code	Description
C1010	mV/pH/EC/DO meter
C1020	mV/pH/EC/SAL/TDS/DO meter

Code	Description	Content
C10xxP	pH meter kit, epoxy electrode	meter + pH electrode SP10T + 2x50ml pH buffers + 50ml electrolyte
C10xxK	EC meter kit, epoxy electrode	meter + EC electrode SK10T + 50ml EC standard
C10xxPK	pH/EC meter kit, epoxy electrodes	meter + pH electrode SP10T + EC electrode SK10T + 2x50ml pH buffers + 50ml electrolyte + 50ml EC standard
C10xxZ	Oxygen meter kit	meter + DO electrode SZ10T
C10xxT	Complete meter kit, epoxy electrode	meter + pH electrode SP10T + EC electrode SK10T + 2x50ml pH buffers + 50ml electrolyte + 50ml EC standard + DO electrode SZ10T
C10xxX	Meter kit without electrodes	meter + 2x50ml pH buffers + 50ml electrolyte + 50ml EC standard
SH300	Flexible electrode holder	

Kits are available for each meter. Replace xx with correct meter number. F.i. C1010P, C1020T, etc...

● Specifications

pH (C1020 only)	Range	0.00...14.00 pH
	Resolution	0.01 pH
	Accuracy	0.2% ± 1 digit
	Calibration	1...3 points
	Buffers	11 pre-programmed
	Temperature compensation	0...100°C
	ISO-pH	6...8 pH
	Slope	80...120%
mV	Range	±1000 mV
	Resolution	1 mV
	Accuracy	0.2% ± 1 digit
	Calibration	1 point
CONDUCTIVITY	Range (cc dependent)	0...100 mS/cm (C1010) 0...1000 mS/cm (C1020)
	Resolution (cc dependent)	0.1 µS/cm (C1010) 0.01 µS/cm (C1020)
	Accuracy	1% f.s. of range
	Calibration	1 point
	Standards	3 pre-programmed
	Cell constant (cc)	1 cm ⁻¹ ±30% (C1010) 0.1/1/10 cm ⁻¹ ±30% (C1020)
	Temperature compensation	0...100°C
	Reference temperature	20° or 25°C
	Temperature coefficient	natural waters (EN27888)
	SALINITY (C1020 only)	Range
Reference temperature		15°C
TDS (C1020 only)	Range	0...100.0 g/l
	Resolution	0.1 mg/l

DISSOLVED OXYGEN	Range	0.00...20.00 mg/l (0...200%)
	Resolution	0.01 mg/l (0.1%)
	Accuracy	1% ± 1 digit
	Calibration	1 point
	Temperature compensation	0...50°C
	Salinity compensation	0...40
	Air pressure compensation	800...1200 hPa
	TEMPERATURE	Range
Resolution		0.1°C
Accuracy		0.5°C
Calibration		1 point
INPUTS	pH/mV	BNC, 10 ¹² Ω
	Conductivity/Dissolved oxygen	BNC
	Temperature	2 banana, for Pt1000
STORAGE MEMORY (C1020 only)	Data sets	300
	CALIBRATION	GLP
DISPLAY	LCD	128x64 pixels
	White back-light	✓
AMBIENT CONDITIONS	Temperature	0...40°C
	Humidity	0...95%, non condensing
POWER SUPPLY	Mains	100...240 VAC, 50/60 Hz
	Low voltage	9...15 VDC
DIMENSIONS	WxDxH	13x18x10 cm
WEIGHT	Meter	600 gr

- **Parameters:** pH, ORP, DO, EC, TDS, SAL, Temperature
- **Gold Plated BNC**
- **Pre-programmed standards**
pH: 1.68, 2.00, 4.00, 4.01 (B504), 6.87, 6.99 (B507), 9.18, 9.21, 9.95 (B510), 10.01, 12.00, 12.45 (at 25°C)
- **Conductivity:** 1413 µS/cm (B560), 12.88 mS/cm (B561), 111.8 mS/cm (B562) (at 25°C)
- **Stability algorithm with intuitive indicator**
- **Easy to use**
- **Ideal for schools and small laboratories**
- **Portable**
- **Accuracy at a budget**



LabArt C51 is a basic, yet complete and accurate portable meter. It can measure all common electrochemical parameters such as pH, ORP, Conductivity, TDS, Salinity and Dissolved Oxygen.

Intuitive menu system with function keys for fast and easy handling.

Free software can be downloaded from our website to copy the logged values to a computer.

Firmware update for future improvements.



SK10T



SP10T



SZ10T

pH/MV Channels	1
EC/TDS/SAL/DO Channels	1
Temperature Channels	1
pH	0.00...14.00 pH
mV	±2000 mV
Conductivity	0...1000 mS/cm (cc dependend)
Salinity	0.0...70.0
TDS	0...100 g/l
Dissolved oxygen	0.00...20.00 mg 0...200%
Temperature	0.0...+100.0°C
Warranty	36 months
Made in Belgium	

Code	Description	Content
C51	mV/pH/EC/SAL/TDS/DO meter	meter only
C51P	pH meter kit, glass electrode	meter + SP20T + 2x50ml pH buffers + 50ml electrolyte + carrying case
C51K	EC meter kit, glass electrode	meter + SK20T + 50ml EC standard + carrying case
C51PK	pH/EC meter kit, glass electrodes	meter + SP20T + EC electrode SK20T + 2x50ml pH buffers + 50ml electrolyte + 50ml EC standard + carrying case
C51Z	Oxygen meter kit	meter + SZ20T + carrying case
C51T	Complete meter kit, glass electrodes	meter + SP20T + SK20T + SZ20T + 2x50ml pH buffers + 50ml electrolyte + 50ml EC standard + carrying case
C51X	Meter kit without electrodes	meter + 2x50ml pH buffers + 50ml electrolyte + 50ml EC standard + carrying case
C51PE	pH meter kit, epoxy electrode	meter + SP10T + 2x50ml pH buffers + 50ml electrolyte + carrying case
C51KE	EC meter kit, epoxy electrode	meter + SK10T + 50ml EC standard + carrying case
C51PKE	pH/EC meter kit, epoxy electrodes	meter + SP10T + SK10T + 2x50ml pH buffers + 50ml electrolyte + 50ml EC standard + carrying case
C51TE	Complete meter kit, epoxy electrodes	meter + SP10T + SK10T + SZ20T + 2x50ml pH buffers + 50ml electrolyte + 50ml EC standard + carrying case
B504	500ml buffer pH 4.00 @ 25°C	
B507	500ml buffer pH 6.99 @ 25°C	
B510	500ml buffer pH 9.95 @ 25°C	

● Specifications

pH	Range	0.00...14.00 pH	
	Resolution	0.01 pH	
	Accuracy	0.2% ± 1 digit	
	Calibration	1...3 points	
	Buffers	11 pre-programmed	
	Temperature compensation	0...100°C	
	ISO-pH	6...8 pH	
mV	Slope	80...120%	
	Range	±2000 mV	
	Resolution	1 mV	
	Accuracy	0.2% ± 1 digit	
CONDUCTIVITY	Calibration	1 point	
	Standards	3 pre-programmed	
	Cell constant (cc)	0.1/1/10 cm ⁻¹ ±30%	
	Temperature compensation	0...100°C	
	Reference temperature	20° or 25°C	
	Temperature coefficient	natural waters (EN27888)	
	Range	0...70	
	Reference temperature	15°C	
	TDS	Range	0...100.0 g/l
		Resolution	0.1 mg/l
	DISSOLVED OXYGEN	Range	0.00...20.00 mg/l (0...200%)
		Resolution	0.01 mg/l (0.1%)
		Accuracy	1% ± 1 digit
		Calibration	1 point
		Temperature compensation	0...50°C
		Salinity compensation	0...40
		Air pressure compensation	800...1200 hPa
	TEMPERATURE	Range	-5...100°C
		Resolution	0.1°C
		Accuracy	0.5°C
Calibration		1 point	
Inputs		pH/mV/Dissolved Oxygen	
INPUTS	Conductivity	BNC	
	Temperature	2 banana, for Pt1000	
	Interface with computer	USB	
COMMUNICATION	Interface with computer	USB	
STORAGE MEMORY	Data sets	50	
CALIBRATION	GLP	✓	
DISPLAY	LCD	160x160 pixels	
	White back-light	✓	
AMBIENT CONDITIONS	Temperature	0...40°C	
	Humidity	0...95%, non condensing	
POWER SUPPLY	Low voltage	9...15 VDC	
	Batteries (included)	4 x 1.2 V, NiMH	
DIMENSIONS	WxDxH	13x18x10 cm	
WEIGHT	Meter	600 gr	

Measurement Channels	4...448
pH	0...14 pH
mV	±2000 mV
Ion	0...100 g/l
Conductivity	0...2000 mS/cm
TDS	0...100 g/l
Dissolved oxygen	0...60 mg/l
Temperature	-5...+105°C
Warranty	36 months
Made in Belgium	

Large measurement channel array.



4...28 pH/mV/Ion channels
4...28 conductivity channels
4...28 oxygen channels
4...28 temperature channels

● Description

Our successful D230 system is a configurable large measurement array. With up to 16 fully loaded D230 racks connected to each other the complete D230 system can measure up to 448 channels.

The system is based upon a D230 rack and 2 different measurement modules: D291 and D292. D291 is 4-channel pH/mV/Ion/Dissolved Oxygen measurement modules. D292 is a 4-channel Conductivity/TDS module. Both modules can be used in the D230 system so you can configure a D230 as you wish.

The data acquisition software of the D230 system is freely downloadable from our website. It is specially designed to control, collect and store data of a D230 system. It runs under Windows 2000 or higher. All channels are processed at the same time, each in its own window. The software automatically detects the maximum number and type of available channels. Data is collected on-line at a programmable interval determined by the program (4s...24h)

● Highlights

Multichannel up to 448 measurements can be performed at the same time and simultaneous displayed on the screen.

No interference between pH/ORP/Ion and conductivity electrodes in the same solution

Free data acquisition software to control, collect and store data of a D230 system.

Table Data is always stored in a table. Each module has its own programmable table containing an unlimited number of lines. Comments can easily be added to each line in a special information column.

Starting Data-logging can start/stop automatically or at a programmable date/time. Data-logging can be stopped or continued at any moment.

Files All data is saved in a user defined file. Just open the file to view, process or print the stored data. All measurements are saved in CSV format which is easily transferred into spreadsheets.

Graphs Graphs are generated using automatic or user defined settings. The number of visible values can be changed at any time. Programmable alarm limits for each graph allow to print a report indicating when limits have been exceeded. Shows statistics about minima, maxima, averages etc...

Settings Languages: English, Dutch or French. The style of each window can be set up separately. Choose fonts, colours etc... Documented printouts will show:

- file name.
- date and time.
- name of the operator.
- name of the company.
- name of the division.
- optional notes by the operator.

All settings are stored in a configuration file and automatically recalled when opening the program.

Functions All functions are accessible through the menu. Only valid options appear in the menu to eliminate set-up errors. Special buttons, icons and short-keys allow the user to easily access the most useful functions. The contents of each window can be transferred to other programs by using a copy function. Tile or cascade the windows and arrange the icons fully automatically or rearrange them manually.

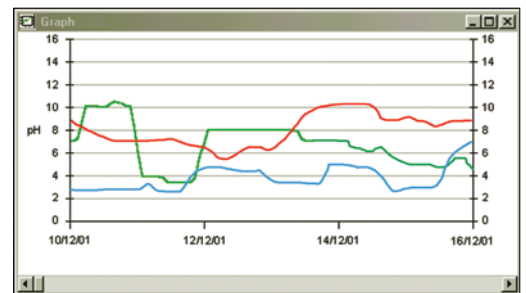
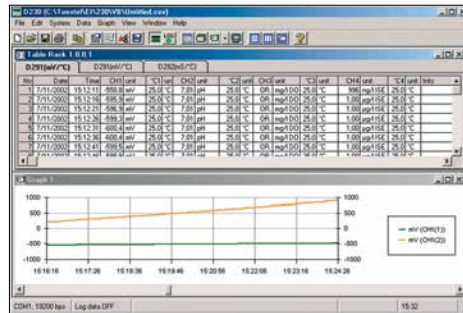
Specifications

pH	Range	0...14 pH
	Resolution	0.001 pH
	Accuracy	0.1% ± 1 digit
	Calibration	1...2 points
	Buffers	9 pre-programmed 2 user specified
	Temperature compensation	-5...+105°C
	ISO-pH	6...8 pH
mV	Range	±2000 mV
	Resolution	0.1 mV
	Accuracy	0.1% ± 1 digit
	Calibration	1 point
Ion	Range	0.01 mg/l...100 g/l
	Resolution	3 digits
	Accuracy	0.5% ± 1 digit
	Calibration	2 points + blank
CONDUCTIVITY	Range (cc dependent)	0...2000 mS/cm
	Resolution (cc dependent)	0.001 µS/cm
	Accuracy	0.5% f.s. of range
	Calibration	1 point
	Standards	3 pre-programmed 2 user specified
	Cell constant (cc)	0.01/0.1/1/10 cm ⁻¹ ±30%
	Temperature compensation	-5...+105°C
	Reference temperature	20° or 25°C
	Temperature coefficient	natural waters (EN27888)
	Capacitive compensation	✓
TDS	Range	0...100 g/l
	Resolution	0.01 mg/l

DISSOLVED OXYGEN	Range	0...60 mg/l (0...600%)
	Resolution	0.01 mg/l (0.1%)
	Accuracy	1% ± 1 digit
	Calibration	1 point
TEMPERATURE	Range	-5...+105°C
	Resolution	0.1°C
	Accuracy	0.3°C
	Calibration	1 point
CHANNELS	pH/mV/Ion/Dissolved oxygen	4...28
	Conductivity	4...28
	Temperature	4...28
INPUTS	pH/mV/Ion/Dissolved oxygen	BNC, 10 ¹² Ω
	Conductivity	BNC
	Temperature	2 banana, for Pt1000
CALIBRATION	GLP	✓
DATA-LOGGING	Data sets	unlimited
	Interval	4 s ... 24 h
SOFTWARE	Languages	EN, NL, FR
AMBIENT CONDITIONS	Temperature	0...40°C
POWER SUPPLY	Humidity	0...95%, non condensing
DIMENSIONS	Mains	210...250 VAC, 50/60 Hz 110...130 VAC, 50/60 Hz
	Weight	48x24x13 cm
WEIGHT	Meter	10 kg

Ordering codes

Code	Description
D230	Data-logger: central unit for 7 modules + software + RS232 cable
D291	Module for pH/mV/Ion/O ₂ /°C with 4+4 channels
D292	Module for conductivity/TDS/°C with 4+4 channels
D298	Data cable to connect 2 data-loggers with each other (optional)
D299	Blanc front panel to cover unused module space (optional)

➔ Supplied with a European mains cord. Add -US for US plug 120 VAC version, -UK for UK plug version, -CH for Swiss plug version,

● pH measurement in different substances

Gas

The only way to measure the pH of a gas is to dissolve it into distilled water and measure the mixture. Technically, the pH of the distilled water/gas mixture will be that of the gas.

Soil

Prepare the sample by combining a 10 g soil sample with distilled water (total volume should be 50 ml), mixing thoroughly, and allowing the mixture to settle for 10 minutes. Carefully insert the pH electrode and allow readings to stabilise.

Ethanol

You need a pH electrode with a low resistance pH bulb, and the reference portion of the electrode should have a double junction design with an outer chamber that is refillable.

Take a 10 ml aliquot of the regular 4 M KCl fill solution and dilute it to volume with the ethanol in a 100 ml volumetric flask. Use this solution to fill the reference chamber of the electrode.

Ethanol solutions require the correct type of liquid junction, that is, one that is easily renewed and cleaned. An open liquid junction or sleeve junction electrode is recommended. The proper functioning of the glass electrode depends on the hydration of the glass layer which takes place on the surface of the pH sensitive glass membrane during soaking and measurement in aqueous solutions.

As long as the electrode is frequently rehydrated, accurate measurements in non-aqueous or partly aqueous solutions such as ethanol are also possible. You are going to have dehydration of the pH bulb and reference junctions with the ethanol. You will have to switch out the electrodes for rehydration every few days. This can be accomplished by soaking in a slightly acidic buffer such as pH 4 buffer.

● ORP Paradoxical measurement

The most common problem reported with regard to ORP determination in environmental water is that readings from various instruments (sometimes with exactly the same sensor type and electronics) differ by a significant margin (50-100 mV) even though the sensors are in the same container of water. To make the problem more perplexing, all of the sensors show identical readings in an ORP standard such as Zobell solution.

The exact explanation for this paradox is sometimes elusive, but there are at least three possible reasons for its occurrence.

1. ORP sensors can show a slow response in environmental water if the platinum button of the probe has been contaminated with extraneous material. Common contaminants include hard water deposits, oil/grease, or other organic matter. If the platinum electrodes in the above example are variably contaminated, then some of them (the more contaminated) will be likely to approach potentiometric equilibrium slower. Under this scenario, if left long enough all the sensors would read the same. However, it might take days for the contaminated sensors to reach their final value, and, therefore, they appear in the time frame of a sampling experiment (< 1 hour), to be different. Naturally, if the electrode contaminant is redox-active, either in itself or because it contains redox-active impurities, the reading from that sensor will exhibit erroneous readings that may never change unless the contaminant is removed.
2. In clean environmental water, there may be very few redox-active species present, and those that are present may be in very low concentration. In many cases, the concentration can be so low that the redox influence of the species is effectively below the detection limit of the method. Under these conditions, the readings will have questionable meaning and could show this type of variation described above. Note that the ORP reading variance associated by this scenario is likely to be exacerbated if any of the electrodes is also contaminated as described above.
3. The composition of the surface of the electrode may not be ideal for the measurement in the medium under investigation. While "platinum" ORP electrodes are primarily composed of the metal itself (in a neutral state), it is well known that the surface of the electrode (where the redox action takes place) is coated to varying extents with a molecular layer of platinum oxide (PtO). The Pt/PtO ratio can change over time, depending on the medium in which the probe is stored, and thus the surface of the electrode actually possesses its own potential that can be variable. If this surface potential is similar to the ORP potential of the medium, then electrode response can be sluggish. The cleaning procedure recommended later in this document will result in a surface characterized by a low Pt/PtO ratio and one that possesses a very positive potential. This should be suitable for most environmental measurements.

The fact that similar or identical ORP sensors read differently in environmental water yet the same in Zobell solution is due to the fact that the concentration of redox-active species (ferricyanide/ferrocyanide for Zobell) is much greater in the standards. This higher concentration usually "swamps out" the inconsistencies related to detection limit problems (caused by low amounts of redox-active species) and response time issues (caused by electrode contamination), thus all sensors respond rapidly and read within the specification of ± 20 mV when in standards.

Controllers



- **Gold Plated BNC**
- **2 Multiparamter Channels**
- **2 (3) Independent Control Systems**
- **Control types**
proportional
on/off
- **Safety Features**
Stop control without stopping measurements
Automatic Resume
Washing Program
Programmable alarm
- **Pre-programmed standards**
pH: 1.68, 2.00, 4.00, 4.01, 6.87, 6.99, 9.18, 9.21, 10.01, 12.00, 12.45 (at 25°C)
Conductivity: 1413 µS/cm, 12.88 mS/cm, 111.8 mS/cm (at 25°C)
- **No interference between electrodes**
- **Stability algorithm with intuitive indicator**
- **Selectable resolution**
- **Capacitive compensation**
- **Galvanic isolated RS485 interface**
- **Galvanic isolated 4-20mA outputs**
- **High Accuracy**
- **Free software**
- **Open Communication Protocol**



FC3020T flowcell with intergrated T sensor

The R3600 adds 2 (3 for R3630) independent programmable control systems to measurement system of C3000 series. It's possible to connect up to 31 controllers with a computer. A programmable alarm function prevents overdosing of chemicals in the process liquid.

R3614 and R3624 are versions with 1 extra DIN connector for 4-pole conductivity electrodes.

Specifications depending on model

Measurement Channels	2 (R3630 3)
Temperature Channels	2 (R3630 1)
Controls	2 (3)
Solid State Relays	4
pH	-2.000...+16.000 pH
mV	±2000.0 mV
Ion	0.01 ng/l...100 g/l
Conductivity	0...2000 mS/cm
Dissolved oxygen	0...60.00 mg/l 0...600%
Free chlorine	0...10 mg/l
Air pressure	600...1300 hPa
Temperature	-5.0...+105.0°C
Digital output	RS485
Analogue output	4..20mA
Warranty	36 months
Made in Belgium	

Code	Description
R3610	Controller for pH/mV/conductivity/dissolved oxygen
R3620	Controller for pH/mV/conductivity/dissolved oxygen/ion
R3630	Controller for pH/mV/conductivity/dissolved oxygen/free chlorine
FC3020T	2 channel flow cell with integrated Pt1000 temperature sensor and mounting accessories excl. electrodes

→ Add -US for 120 VAC versions.

Specifications

pH	Range	-2...+16 pH
	Resolution	0.001 pH
	Accuracy	0.1% ± 1 digit
	Calibration	1...5 points
	Buffers	11 pre-programmed 5 user specified
	Temperature compensation	-5...+105°C
	ISO-pH	6...8 pH
mV	Slope	80...120%
	Range	±2000 mV
	Resolution	0.1 mV
CONDUCTIVITY	Accuracy	0.1% ± 1 digit
	Calibration	1 point
	Range (cc dependent)	0...2000 mS/cm
	Resolution (cc dependent)	0.001 µS/cm
	Accuracy	0.5% f.s. of range
	Calibration	1...3 points
	Standards	3 pre-programmed 3 user specified
	Cell constant (cc)	0.1/1/10 cm ⁻¹ ±30%
	Temperature compensation	-5...+105°C
	Reference temperature	20° or 25°C
	Temperature coefficient	natural waters (EN27888)
Capacitive compensation	✓	
DISSOLVED OXYGEN	Range	0...60 mg/l (0...600%)
	Resolution	0.01 mg/l (0.1%)
	Accuracy	1% ± 1 digit
	Calibration	1 point
	Temperature compensation	0...50°C
	Salinity compensation	0...40
ION (R3620 only)	Air pressure compensation	600...1300 hPa
	Range	0.01 ng/l...100 g/l
	Resolution	3 digits
	Accuracy	0.5% ± 1 digit
	Calibration	2...5 points + blank
FREE CHLORINE (R3630 only)	Range	0...10 mg/l
	Resolution	0.01 mg/l
	Accuracy	5% ± 1 digit
	Calibration	1 point
	pH compensation	5...9 pH
	Temperature compensation	10...40°C
min. flow rate	20 cm/s	

TEMPERATURE	Range	-5...+105°C	
	Resolution	0.1°C	
	Accuracy	0.1°C	
AIR PRESSURE	Calibration	1 point	
	Range	600...1300 hPa	
CHANNELS	Calibration	1 point	
	Measurement	2	
INPUTS	Temperature	2	
	Measurement	2 BNC, 10 ¹² Ω	
	Temperature	1 DIN (R36x4 only)	
CALIBRATION	Temperature	2 BNC, for Pt1000	
	Reminder	0...999 h	
	GLP	✓	
CONTROL	independent controls	2	
	On/Off	✓	
	Proportional	✓	
	Wash program	✓	
	Alarm timer	✓	
DISPLAY	LCD	128x64 pixels	
	White back-light	✓	
	Selectable resolution	✓	
	Real time clock	✓	
	Built-in help	✓	
	Languages	English Dutch French German	
	ANALOG OUTPUTS	Two outputs	4...20 mA, max. 300 Ω load
	COMMUNICATION	RS485, baud rate	300...19200 b/s
DATA-LOGGING	Data sets	12000 + °C/date/time	
	Modes	all	
	Interval	1 s...4 h	
RELAY OUTPUT	Four relays	4 solid state	
	Voltage	12...250 VAC/ min. 1 mA/ max. 1 A	
SECURITY	Identification number	✓	
	Password protection	✓	
AMBIENT CONDITIONS	Temperature	0...40°C	
	Humidity	0...95%, non condensing	
POWER SUPPLY	Mains	210...250 VAC, 50/60 Hz	
DIMENSIONS	WxDxH	28x17x6 cm	
WEIGHT	Meter	1.3 kg	

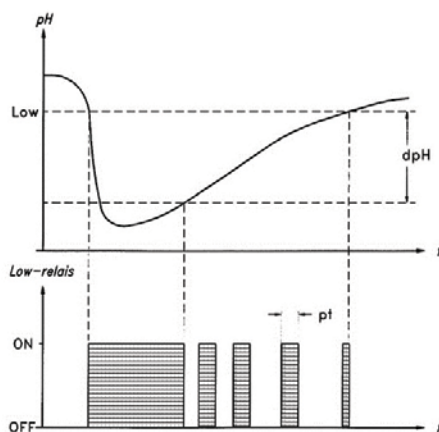

FC3020T flowcell with intergrated T sensor

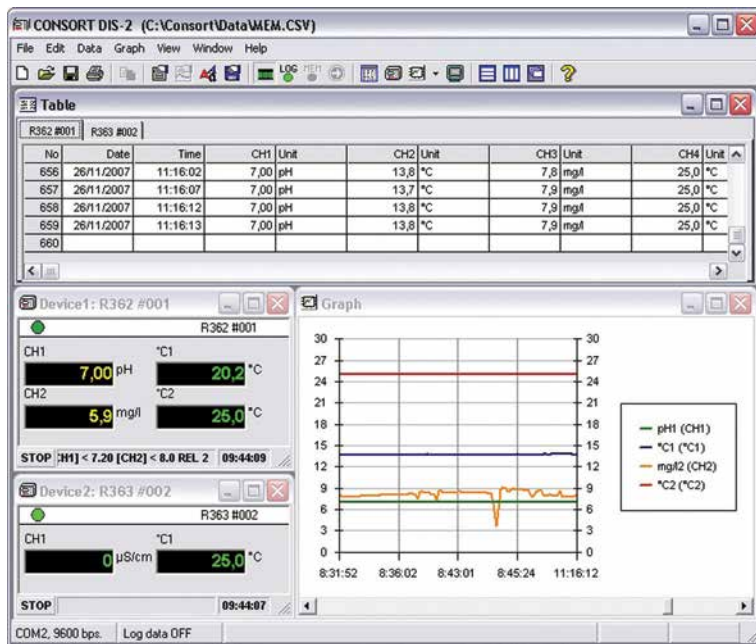

The screenshot shows the configuration window 'C:\Toeste\Dis2.cfg'. It has tabs for 'Log', 'Connection', 'Language', and 'Devices'. The 'Devices' tab is active, showing a table with columns 'No', 'Device', 'ID.no.', and 'Channels'. The table lists 9 devices, all with 4 channels.

No	Device	ID.no.	Channels
1	R362	001	4
2	R362	002	4
3	R362	003	4
4	R363	004	4
5	R363	005	4
6	R363	006	4
7	R362	007	4
8	R362	008	4
9	R362	009	4



● Description

This free software package is specially designed to collect, store and manage data from the R36xx controllers when equipped with a RS485 interface. It can also be used with the following previous models or versions when equipped with an RS485 interface: R305, R315, R335.

DIS-2 runs under Windows™ 2000 or higher and can be downloaded from www.consort.be

● Highlights

Data acquisition. All measurements of all instruments are processed at the same time, each in its own window. Data is collected on-line at a programmable interval determined by the program (1 s ... 24 h).

Starting By using a program-key, the data-logging will start automatically after opening the program. Data-logging can be stopped or continued at any moment. Data, which is stored in the internal memory of the connected instrument, can also be read and processed.

Table Data is always stored in a table. Comments can be added to each line in a special information column.

Files All data is saved in a user defined file. Just open the file to view, process or print the stored data. The incoming data can be stored immediately in a file. All measurements are saved in CSV format which is easily transferred into spreadsheets.

Graphs are generated using automatic or user defined settings. The number of visible values can be changed at any time. Programmable alarm limits for each graph allow to print a report indicating when limits have been exceeded and it shows statistics about minima, maxima and averages.

Communication port COM1 to COM9 can be used to connect up to nine series of max. 31 instruments. Baud rate: 300..9600 b/s.

Terminal shows exactly how data is receive. It enables the user to check for possible errors in the data transmission.

Settings The style of each window can be set up separately. Choose fonts, colours etc... All settings are stored in a configuration file and automatically recalled when opening the program. Documented printouts will show:

- file name.
- date and time.
- name of the operator.
- name of the company.
- name of the division.
- optional notes by the operator.

Functions are accessible through the menu. Only valid options appear in the menu to eliminate set-up errors. Special buttons, icons and short-keys allow the user to easily access the most useful functions. The contents of each window can be transferred to other programs by using a copy function.

Electrodes



● Overview

Consort offers a wide variety high quality electrochemical analytical sensors. Our pH, ORP (Oxidation-Reduction Potential), Conductivity, Oxygen and Ion Selective Electrodes (ISEs) are designed for Laboratory, Industrial, Biotechnology and Medical applications.

The most common electrodes are in our catalogue. We can supply variations depending on your needs: body style, submersible, cable length, body length, connector type, ATC type,...

Most of our electrodes can be delivered from stock. ISE's are never delivered from stock because of it's limited shelf life. An ISE is manufactured on demand and as such will guarantee an ideal shelf life combined with a low price.

● Tips and tricks

While calibrating or measuring, all solutions should be stirred gently to ensure the electrode gives a true representation of the beaker contents.

Calibration solutions with values near the expected sample value should be chosen. Only fresh calibration solutions should be used. Changing all solutions daily is a good practice. All solutions should be maintained at equal temperature.

Rinse the electrode twice between measurements: first thoroughly in distilled water and then with a small amount of the next sample to be measured. Allow the electrodes sufficient time to stabilise while calibrating or measuring. A stability indicator on all of our meters prompts the user when readings should be taken.

● About B, N, T, X, Y

Our electrodes have different options indicated with a suffix. Here is an explanation of the different suffixes:

- B** 1m cable
1 BNC connection
- N** 1m cable
2 banana connections
- T** built-in ATC (Pt1000)
1m cable
1 BNC connection
2 banana connections for ATC
- X** S7 screw connection (separate cable (SCxxB) needed)
- Y** S8 screw head for in-line use, screw connection (separate cable (SCxxB) needed)

Application	SP10	SP11	SP20	SP21	SP22	SP24	SP26	SP27	SP28	SP29	SO50	SO60	SO65
Agar						•	•						
Agriculture	•	•	•	•									
Alkaline solutions					•								
Beer					•		•						
Blood			•	•			•		•				
Bread		•				•							
Cheese						•							
Cosmetics					•		•						
Cream					•		•						
Distilled water							•						
Dough		•				•							
Education	•	•	•	•							•	•	•
Emulsion							•						
Fat					•		•						
Field use	•	•									•		
Fruit			•	•	•	•			•				
Fish						•							
Glucose					•		•						
Honey							•						
Industrial, general		•									•		
Ink		•			•		•						
Juice			•	•	•								
Lab flasks, tall-form										•			
Laboratory, general		•	•	•	•							•	•
Lacquer					•		•						
Liquor					•		•						
Low ionic strength							•						
Meat						•							
Micro volume									•	•			
Milk					•		•						
Non-aqueous media							•						
Oil in water							•						
Paint					•		•						
Paper								•					
Photo bath					•		•						
Pure water		•	•	•	•		•						
Sausage						•							
Sea water	•	•	•	•	•						•	•	•
Soil	•	•	•	•		•							
Solvent in water					•		•						
Suspension							•						
Swimming pool	•	•	•	•	•						•	•	
Syrup							•						
Tap water		•	•	•	•							•	•
Temperature, high					•								
Test tube									•	•			
TRIS buffer					•		•						
Waste water		•			•		•					•	•
Wine					•		•						
Viscosity, high					•		•					•	
Yogurt					•		•					•	



SP11



SK27

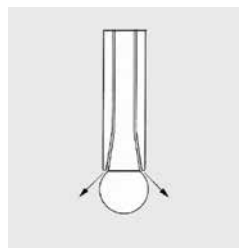
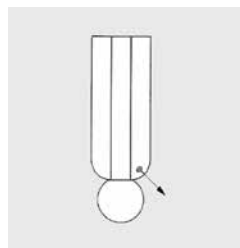
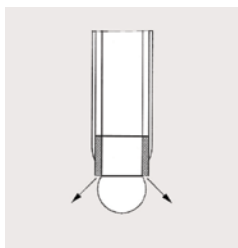
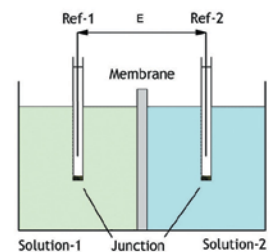
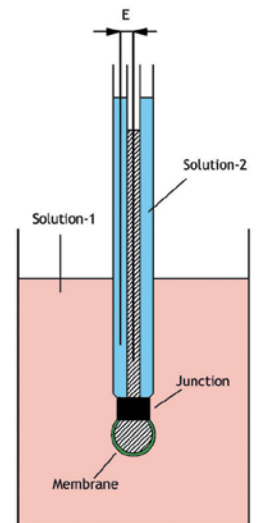

● pH electrodes

Code	Body	Junction	Sealed	pH	°C	size	
SP10B SP10T	General	Epoxy	Single	yes	0...14	0...80	110xØ12
SP11B SP11T SP11X SP11Y	Rugged Tuff-Tip	Epoxy	Double	yes	0...14	0...100	110xØ12
SP20B SP20T	General	Glass	Single	yes	0...14	0...100	110xØ12
SP21B SP21T SP21X	General	Glass	Single	no	0...14	0...100	110xØ12
SP22X SP22Y	High Temp.	Glass	Double	yes	0...14	5...110	110xØ12
SP24B SP24X	Spear Tip	Ultem Glass	Double	yes	0...14	0...80	25xØ5
SP26X	Sleeve Junction	Glass	Double	no	0...14	0...100	110xØ12
SP27X	Flat Surface	Epoxy	Single	yes	0...14	0...80	110xØ12
SP28X	Micro Electrode	Glass	Single	no	0...14	0...80	130xØ4
SP29X	Test Tube	Glass	Single	no	0...14	0...100	250xØ8
SP9xY	Sterilisable max 10 bar	Glass	Double	yes	0...13	-5...135	
SP91Y: 110xØ12 mm		SP92Y: 120xØ12 mm		SP93Y: 130xØ12 mm			
SP94Y: 160xØ12 mm		SP95Y: 210xØ12 mm		SP97Y: 310xØ12 mm			
SP98Y: 360xØ12 mm							
→ add -KIT to order an electrode with 50ml pH4 and pH7 + 50ml 3M KCl							



● Special electrodes

Code	Body	°C	size		
SP04X	Titration	glass	double platinum	0...100	110xØ12
SP35B	pH/ORP combi	Glass	sealed 0...12 pH 0...±2000 mV single junction	0...100	110xØ12



● ORP electrodes

Code	Body	Junction	Sealed	mV	°C	size	
SO50X SO50Y	Platinum	Epoxy	Single	yes	0...±2000	0...80	110xØ12
SO60X	Platinum	Glass	Single	no	0...±2000	0...100	110xØ12
SO65X	Silver	Glass	Single	no	0...±2000	0...100	110xØ12

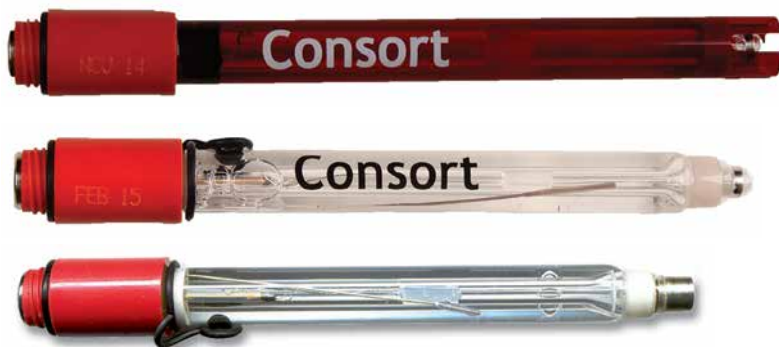

● Dissolved oxygen electrode

Code	Type	Body	mg/l	°C	size	
SZ20T	Galvanic	1m cable, solid state, maintenance free	Delrin	0...60	0...50	110xØ12



● Conductivity electrodes

Code	Body	Poles	CC	°C	size	
SK10B SK10T SK10Y	General Graphite	Epoxy	2	1 cm ⁻¹	0...80	110xØ12
SK12T	Low cond. Graphite	Epoxy	2	0.1 cm ⁻¹	0...80	110xØ12
SK20B SK20T SK20Y	General Platinum	Glass	2	1 cm ⁻¹	0...110	110xØ12
SK21T SK21Y	Low cond. Platinum	Glass	2	0.1 cm ⁻¹	0...110	110xØ12
SK23T	High cond. Platinum	Glass	2	10 cm ⁻¹	0...110	130xØ12
SK24T	Micro elec. Platinum	Glass	2	1 cm ⁻¹	0...100	110xØ6
SK27B SK27T	Flat Surface Graphite	Epoxy	2	1 cm ⁻¹	0...80	110xØ12
SK40T	4-pole Graphite	Epoxy	4	0.5 cm ⁻¹	0...80	110xØ15
SK41T	4-pole Platinum	Glass	4	1 cm ⁻¹	0...100	110xØ12
SK43T	4-pole High cond. Platinum	Glass	4	10 cm ⁻¹	0...100	110xØ12

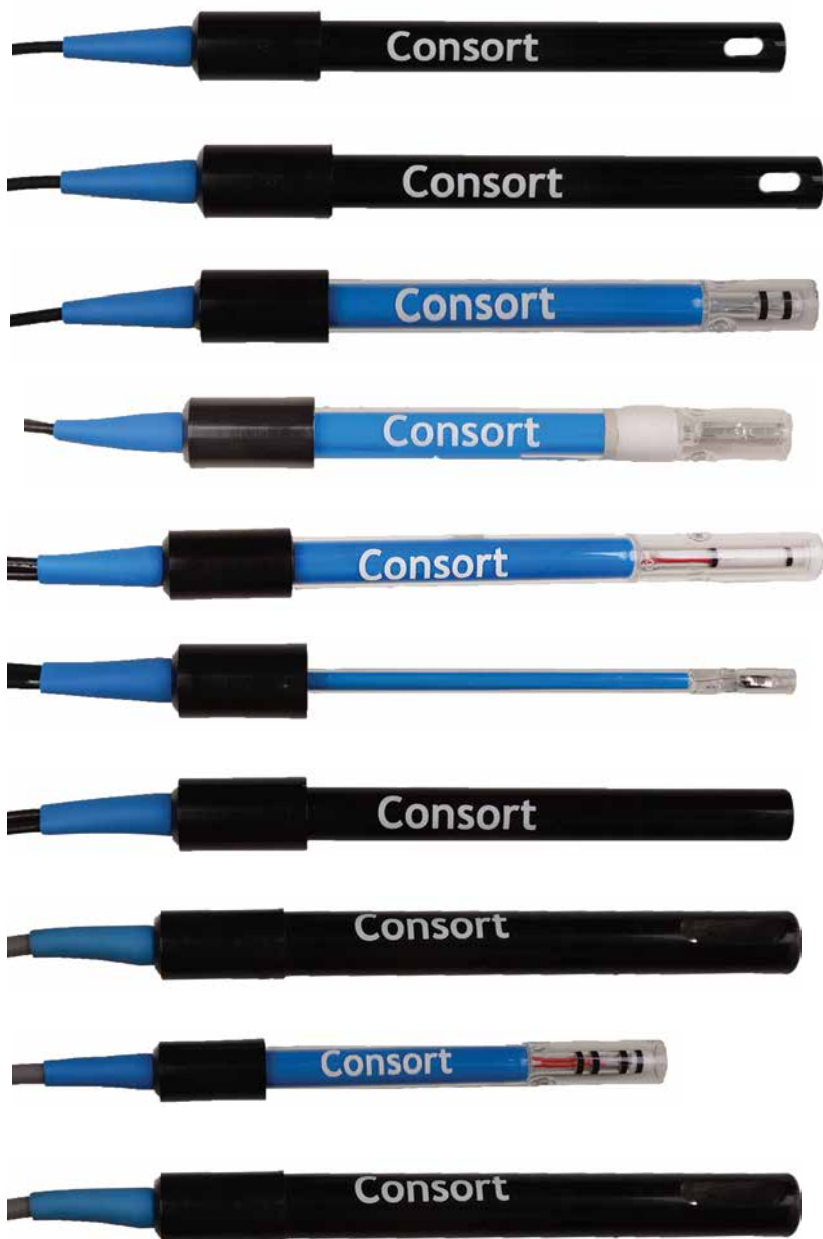

● Temperature Compensator

Code	Body	type	°C	size
ST10N	Teflon coated stainless steel	Pt1000	-30...+130	110xØ4
ST20N	Glass	Pt1000	-30...+130	110xØ8
ST21Y	Glass	Pt1000	-30...+130	110x12



Polymer electrodes consist of various ion-exchange materials in an inert matrix such as PVC, polythene or silicone rubber.

Solid state electrodes utilise relatively insoluble inorganic salts in a membrane.

Glass membrane electrodes are formed by the doping of the silicon dioxide glass matrix with various chemicals.

Gas sensing electrodes are available for the measurement of ammonia, carbon dioxides and nitrogen oxides.



All models are combination electrodes and have an epoxy body.

Dimensions: **110xØ12 mm**

MODEL	ION	SENSOR	RANGE (M)	RANGE (ppm)	°C	INTERFERENCES	pH	ELECTROLYTE
ISE20B	Ammonium NH ₄ ⁺	polymer	5.10 ⁻⁶ - 10 ⁰	0.1 - 18000	0 - 50	K ⁺	4 - 10	NaCl
ISE22B	Cadmium Cd ²⁺	solid state	10 ⁻⁷ - 10 ⁻¹	0.01 - 11200	0 - 50	Cu ²⁺ , Hg ²⁺ , Ag ⁺ , high levels of Fe ²⁺ and Pb ²⁺	2 - 12	KNO ₃
ISE23B	Calcium Ca ²⁺	polymer	5.10 ⁻⁶ - 10 ⁰	0.2 - 40000	0 - 50	Pb ²⁺ , Hg ²⁺ , Cu ²⁺ , Ni ²⁺	3 - 10	KCl
ISE24B	Chloride Cl ⁻	solid state	5.10 ⁻⁵ - 10 ⁰	1.8 - 35500	0 - 50	I ⁻ , Br ⁻ , CN ⁻ , S ²⁻	1 - 12	KNO ₃
ISE25B	Copper Cu ²⁺	solid state	10 ⁻⁸ - 10 ⁻¹	0.00064 - 6350	0 - 50	Hg ²⁺ , Ag ⁺ , high levels of Cl ⁻ , Br ⁻ , Fe ²⁺ and Cd ²⁺	2 - 12	KNO ₃
ISE26B	Cyanide CN ⁻	solid state	5.10 ⁻⁶ - 10 ⁻²	0.13 - 260	0 - 50	Cl ⁻ , Br ⁻ , I ⁻ , S ²⁻	11 - 13	KNO ₃
ISE27B	Fluoride F ⁻	solid state	10 ⁻⁶ - sat.	0.02 - sat.	0 - 50	OH ⁻	5 - 8	KCl
ISE29B	Iodide I ⁻	solid state	5.10 ⁻⁸ - 10 ⁰	0.006 - 127000	0 - 50	S ²⁻ , CN ⁻ , Cl ⁻ , Br ⁻ , S ₂ O ₃ ²⁻ , NH ₃	0 - 14	KNO ₃
ISE30B	Lead Pb ²⁺	solid state	10 ⁻⁶ - 10 ⁻¹	0.2 - 20700	0 - 50	Hg ²⁺ , Ag ⁺ , Cu ²⁺ , high levels of Fe ²⁺ and Cd ²⁺	3 - 8	KNO ₃
ISE31B	Nitrate NO ₃ ⁻	polymer	7.10 ⁻⁶ - 10 ⁰	0.5 - 62000	0 - 50	I ⁻ , ClO ₄ ⁻ , CN ⁻ , BF ₄ ⁻	2.5 - 11	(NH ₄) ₂ SO ₄
ISE32B	Perchlorate ClO ₄ ⁻	polymer	7.10 ⁻⁶ - 10 ⁰	0.7 - 99500	0 - 50	-	2.5 - 11	(NH ₄) ₂ SO ₄
ISE33B	Potassium K ⁺	polymer	10 ⁻⁶ - 10 ⁰	0.04 - 39000	0 - 50	Cs ⁺ , NH ₄ ⁺	2 - 12	NaCl
ISE34B	Silver/Sulphide Ag ⁺ /S ²⁻	solid state	10 ⁻⁷ - 10 ⁰	0.01 - 107900 0.003 - 32000	0 - 50	Hg ⁺ , Hg ²⁺	2 - 12	KNO ₃
ISE35B	Sodium Na ⁺	glass	10 ⁻⁶ - sat.	0.02 - sat.	0 - 50	H ⁺ , K ⁺ , Li ⁺ , Ag ⁺ , Cs ⁺ , TI ⁺	5 - 12	NH ₄ Cl
ISE37B	Water hardness Ca ²⁺ /Mg ²⁺	polymer	10 ⁻⁵ - 10 ⁰	0.4 - 4000 (Ca ²⁺)	0 - 50	Cu ²⁺ , Zn ²⁺ , Ni ²⁺ , Fe ²⁺	5 - 10	KCl
ISE50B	Ammonia NH ₃	gas sensing	5.10 ⁻⁷ - 10 ⁰	0.01 - 17000	0 - 50	volatile amines	11 - 13	NH ₄ Cl
ISE51B	Carbon dioxide CO ₂ /CO ₃ ²⁻	gas sensing	10 ⁻⁴ - 10 ⁻²	4.4 - 440	0 - 50	volatile weak acids	4.8 - 5.2	NaHCO ₃
ISE52B	Nitrogen oxides NO _x	gas sensing	5.10 ⁻⁶ - 5.10 ⁻³	0.2 - 220	0 - 50	SO ₂ , HF, acetic acid	1.1 - 1.7	NaNO ₂

● pH Solutions

Code	Description	
B004	Coloured buffer 4 pH	50 ml
B007	Coloured buffer 7 pH	50 ml
B010	Coloured buffer 10 pH	50 ml
B504	Coloured buffer 4 pH	500 ml
B507	Coloured buffer 7 pH	500 ml
B510	Coloured buffer 10 pH	500 ml
B520	Electrolyte, 3M KCl	500 ml
B530	Electrode cleaning solution	500 ml



Colour coded to reduce errors
Certified to 0.02 pH

● ORP Solutions

Code	Description	
B071	Redox standard solution 124 mV	50 ml
B072	Redox standard solution 358 mV	50 ml
B571	Redox standard solution 124 mV	500 ml
B572	Redox standard solution 358 mV	500 ml
B520	Electrolyte, 3M KCl	500 ml
B530	Electrode cleaning solution	500 ml



Certified to 1 mV at 25°C.

● Conductivity Solutions

Code	Description	
B060	Calibration solution 0.01 M KCl (1413 µS/cm at 25°C)	50 ml
B061	Calibration solution 0.1 M KCl (12.88 mS/cm at 25°C)	50 ml
B062	Calibration solution 1 M KCl (111.8 mS/cm at 25°C)	50 ml
B066	Calibration solution 200 mS/cm (at 25°C)	50 ml
B560	Calibration solution 0.01 M KCl (1413 µS/cm at 25°C)	500 ml
B561	Calibration solution 0.1 M KCl (12.88 mS/cm at 25°C)	500 ml
B562	Calibration solution 1 M KCl (111.8 mS/cm at 25°C)	500 ml
B566B	Calibration solution 200 mS/cm (at 25°C)	500 ml



Certified to 0.5%

● ISE Solutions

Code	Description	
ISC20	Calibration solution, 1000 ppm ammonium	475 ml
ISC21	Calibration solution, 1000 ppm bromide	475 ml
ISC23	Calibration solution, 1000 ppm calcium	475 ml
ISC24	Calibration solution, 1000 ppm chloride	475 ml
ISC25	Calibration solution, 1000 ppm copper	475 ml
ISC27	Calibration solution, 1000 ppm fluoride	475 ml
ISC28	Calibration solution, 1000 ppm fluoroborate	475 ml
ISC29	Calibration solution, 1000 ppm iodide	475 ml
ISC31	Calibration solution, 1000 ppm nitrate	475 ml
ISC32	Calibration solution, 1000 ppm perchlorate	475 ml
ISC33	Calibration solution, 1000 ppm potassium	475 ml
ISC34	Calibration solution, 1000 ppm silver/sulphide	475 ml
ISC35	Calibration solution, 1000 ppm sodium	475 ml
ISC37	Calibration solution, 1000 ppm water hardness	475 ml
ISC50	Calibration solution, 1000 ppm ammonia	475 ml
ISC51	Calibration solution, 1000 ppm carbon dioxides	475 ml

→ Other solutions should be prepared locally.

Code	Description	
ISA20	ISA solution for ammonium, potassium	475 ml
ISA21	ISA solution for bromide	475 ml
ISA22	ISA solution for cadmium	475 ml
ISA23	ISA solution for calcium	475 ml
ISA24	ISA solution for chloride	475 ml
ISA25	ISA solution for copper	475 ml
ISA27A	ISA solution for fluoride, TISAB-1	475 ml
ISA27B	ISA solution for fluoride, TISAB-2	475 ml
ISA27C	ISA solution for fluoride, TISAB-3	475 ml
ISA28	ISA solution for fluoroborate	475 ml
ISA29	ISA solution for iodide	475 ml
ISA30	ISA solution for lead	475 ml
ISA31	ISA solution for nitrate	475 ml
ISA32	ISA solution for perchlorate	475 ml
ISA33	ISA solution for potassium	475 ml
ISA34	ISA solution for silver/sulphide	475 ml
ISA35	ISA solution for sodium	475 ml
ISA37	ISA solution for water hardness	475 ml
ISA51	ISA solution for carbon dioxides	475 ml
ISA52	ISA solution for nitrogen oxides	475 ml

→ Other solutions should be prepared locally.

● Electrode cables and adaptors

Code	Description
SC01B	S7/S8 cable, 1 m, with BNC plug
SC03B	S7/S8 cable, 3 m, with BNC plug
SC06B	S7/S8 cable, 6 m, with BNC plug
SC15B	S7/S8 cable, 15 m, with BNC plug
SC30B	S7/S8 cable, 30 m, with BNC plug
ADAPT-BNC-DIN	Adaptor, BNC to DIN socket
ADAPT-BNC-BANANA	Adaptor, BNC to 2 banana
BOTTLE-ELECTRODE	Storage bottle for electrodes, 8 ml

→ Other lengths or plugs on demand



AP414

Thermal printer



Serial (RS232) and parallel (Centronix) input.
 Thermal dot matrix 9x320 dots.
 Prints 40 columns (normal) or 80 columns (condensed).
 Paper width: 112 mm.
 Roll length: ±28 m.

Supplied with manual, 1 roll of thermal paper, mains adaptor (230 VAC) and RS232 cable. Optional rechargeable battery pack.

Code	Description
AP414	Serial printer + mains adaptor + RS232 cable
AM112	Replacement paper, 112 mm x 25 m
AP4005	Rechargeable battery pack (optional)

SH300

Electrode holder



Model SH300 holds up to three standard electrodes. Its heavy base and very stable flexible arm allow the electrodes to move sideways or up and down while keeping them at a constant vertical angle.

Code	Description
SH300	Flexible electrode holder

Why is a double junction electrode better than a single junction electrode?

A double junction electrode is less likely to become clogged because the second junction is located higher up in the probe out of contact with the sample. It is also less sensitive to pollution as the first reference solution chamber is isolated from the measurement solution by means of a second chamber that acts as a salt bridge.

How often do I need to calibrate my pH meter?

This depends on the type of products being measured, the maintenance and the required accuracy. It may be weekly, daily or before each use or set of uses.

How far can my pH electrode be from my meter? What if it is too far?

The maximum distance an electrode can be from a pH meter is about 15 m, sometimes more and depends on the environment where it is placed. If the distance is greater, you will need a transmitter. Use either a transmitter or purchase an industrial electrode with a built-in transmitter. A transmitter will allow you to use your electrode up to 300 m from your meter provided you are not in a noisy environment.

If measuring the entire range of pH what buffers should be used?

At least 3 buffers, e.g. pH 4, 7 and 10.

What pH electrode do I use for a specific application?

Follow the general rules below for selecting the right pH electrode:

Glass bodied pH electrodes may be used in most sample types.

Epoxy bodied pH electrodes are designed for rugged environments, multiple-user situations, and field or plant applications. Epoxy bodied pH electrodes should not be used in organic solvents.

For situations containing proteins, sulphide, and TRIS, use double junction electrodes.

For viscous or dirty samples, use sleeve junction electrodes for best results and easy cleaning.

Do pH buffers and filling solutions have a shelf-life?

The typical shelf-life for pH buffers and filling solutions is 2 years unopened and 6 months open. For best results, the pH buffer bottles should be sealed promptly to avoid carbon dioxide absorption.

What is a good pH electrode slope range?

The acceptable slope range is 92% to 102%. Slopes below 92% indicate that the electrode may require cleaning or if cleaning does not help, the electrode should be replaced. Slopes above 102% indicate that the pH buffers are contaminated.

What is a good pH electrode ISO-pH range?

The acceptable slope range is 6.5 to 7.5 pH. Values outside this range indicate that the electrode may require cleaning or if cleaning does not help, the electrode should be replaced.

Do I need an Automatic Temperature Compensation (ATC) probe?

The most common cause of error in pH measurements is temperature. The slope of a pH electrode is highly dependent of temperature, and pH buffer values and sample values change with temperature. For the most accurate results an ATC probe is always recommended. There are three advantages for using an ATC probe. The meter recognises a particular pH buffer and autocalibrates with the correct pH value at the current temperature. The meter calculates and stores the correct slope value. The meter automatically adjusts the stored slope in memory to display the temperature adjusted pH value of the sample.

What is the best absolute accuracy I can achieve?

Measuring errors depend on the electronic accuracy of the meter (generally 0.01 pH), the accuracy of the two buffers (generally 0.02 pH) and the chemical behaviour of the electrode. This results in an error of minimum 0.05 pH provided the solutions are stirred. It is better to consider 0.1 pH as the best possible absolute accuracy. In extreme situations like measuring very low or high pH measurements, difficult solutions, or temperatures far from room temperature will increase the errors.

Why will my pH system no longer autocalibrate?

When the pH system will not autocalibrate, the meter, pH electrode and pH buffers should be checked systematically. If your meter has a mV mode, measure the electrode mV in pH buffers:

- The electrode mV in a pH 7 buffer should be 0 ± 30 mV.
- The electrode mV in a pH 4 buffer (at 25°C) should be 160 to 180 mV more than the value in pH 7.
- The electrode mV in a pH 10 buffer (at 25°C) should be 160 to 180 mV less than the value in pH 7.

If the mV values are outside of the above ranges, clean the pH electrode. If cleaning does not return the mV to an acceptable range, replace the electrode. Note: as long as the pH electrode has a slope between 92% and 102%, the electrode should be working properly. The pH buffers should be replaced if the measured mV values are outside of the acceptable ranges. Contaminated buffers may slightly contribute to shifted mV values.

My pH electrode is drifting. What should I do?

There are three possible causes for electrode drift:

If the electrode is new (or has been dry) and drifting, the electrode may not be properly conditioned. Refer to the appropriate electrode instruction manual for details.

If the electrode is stable in buffers but not in the sample, the electrode may be incompatible with the sample or application.

If the electrode is drifting in buffers and samples, the electrode may require cleaning.

Electrophoresis Power Supplies



- On screen help in 4 languages
- Real Time Clock
- Various running modes:
 - Simple Mode
 - 9x9 Method Programming Mode
 - Voltage Ramp Mode
 - Timer Mode
- Constant voltage/Constant current/Constant power
- Automatic cross-over
- Automatic recovery after power failure
- Password protection
- Data-logging
- Remote control via open communication protocol
- Safety features:
 - Ground leakage detection
 - Overload protection
 - Smooth voltage rise
 - No load detection
 - Isolated USB communication
- Free software and firmware updates



EV2000 series is a robust 150W power supply in a small housing and designed to be easy to use.

EV2310 (300V, 1000mA):

An excellent choice for blotting, multiple horizontal and vertical gels.

EV2650 (600V, 500mA):

All round power supply suitable for most tanks and applications.

EV2230 (1500V, 200mA):

Suitable for higher voltage applications

EV2320 (3000V, 100mA):

A high voltage power supply in a small form factor



EVS3100-BLOT



EHS3660-SYS

EV2000 series has a firmware upgrade capability. Moreover EV2000 series has a continuous logging combined with a real time clock. The complete EV series can keep its voltage constant at low currents without problem and will keep on functioning at low and high temperatures. Consort Power Supplies are the most robust, long lasting and durable electrophoresis power supplies in the market.

Specifications depending on model

Power	0-150 W
Voltage	0-300 V to 0-3000V
Current	0-100 mA to 0-1000mA
Outputs	4
Operating Modes	4
	Simple Mode
	9x9 Method Programming Mode
	Voltage Ramp mode
	Timer Mode (time or Vh)

- USB interface
- Datalogging
- Real Time Clock
- Mutiple safety features

Warranty 36 months
Made in Belgium

Code	Description
EV2310	Power supply, 300 V, 1000 mA, 150 W
EV2650	Power supply, 600 V, 500 mA, 150 W
EV2230	Power supply, 1500 V, 200 mA, 150 W
EV2320	Power supply, 3000 V, 100 mA, 150 W
EVS3100-BLOT	Mini Tank Blotter (10x10cm) with 4 cassettes
EHS3610-SYS	Maxi horizontal unit 23x25 cm
→ Supplied with a european mains cord + USB cable	

● Specifications

	EV2310	EV2650	EV2230	EV2320
VOLTAGE	0...300 V	0...600 V	0...1500 V	0...3000 V
CURRENT	0...1000 mA	0...500 mA	0...200 mA	0...100 mA
POWER	0...150 W	0...150 W	0...150 W	0...150 W
PARAMETER RANGE	1...100% of full scale	1...100% of full scale	1...100% of full scale	1...100% of full scale
TIMER	0...99:59 h	0...99:59 h	0...99:59 h	0...99:59 h
VOLT-HOURS	0...99.99 kWh	0...99.99 kWh	0...99.99 kWh	0...99.99 kWh
DISPLAY	graphical	graphical	graphical	graphical
SETUP RESOLUTION	1 V, 1 mA, 1 W	1 V, 1 mA, 1 W	1 V, 1 mA, 1 W	1 V, 1 mA, 1 W
MEASUREMENT RESOLUTION	1 V, 1 mA, 0.1 W	1 V, 0.1 mA, 0.1 W	1 V, 0.1 mA, 0.1 W	1 V, 1 mA, 0.1 W
PROGRAMS	9x9 set of parameters	9x9 set of parameters	9x9 set of parameters	9x9 set of parameters
OUTPUTS	4 in parallel, 4 mm sockets	4 in parallel, 4 mm sockets	4 in parallel, 4 mm sockets	4 in parallel, 4 mm sockets
MINIMUM LOAD RESISTANCE	10 Ω	30 Ω	300 Ω	600 Ω
NO LOAD DETECTION	✓	✓	✓	✓
GROUND LEAKAGE DETECTION	✓	✓	✓	✓
OVERLOAD DETECTION	✓	✓	✓	✓
COMPUTER CONTROL	✓	✓	✓	✓
PASSWORD PROTECTION	✓	✓	✓	✓
DATA-LOGGING	3600 values	3600 values	3600 values	3600 values
INTERVAL	1...60 seconds	1...60 seconds	1...60 seconds	1...60 seconds
REAL TIME CLOCK	✓	✓	✓	✓
USB INTERFACE	✓	✓	✓	✓
AMBIENT TEMPERATURE	0...40°C	0...40°C	0...40°C	0...40°C
RELATIVE HUMIDITY	0...95%, non condensing	0...95%, non condensing	0...95%, non condensing	0...95%, non condensing
POWER REQUIREMENTS	210-250 VAC, 50/60 Hz, 200 W 100-125 VAC, 50/60 Hz, 200 W	210-250 VAC, 50/60 Hz, 200 W 100-125 VAC, 50/60 Hz, 200 W	210-250 VAC, 50/60 Hz, 200 W 100-125 VAC, 50/60 Hz, 200 W	210-250 VAC, 50/60 Hz, 200 W 100-125 VAC, 50/60 Hz, 200 W
DIMENSIONS (WxDxH)	24x20x13 cm	24x20x13 cm	24x20x13 cm	24x20x13 cm
WEIGHT	6 kg	6 kg	6 kg	6 kg

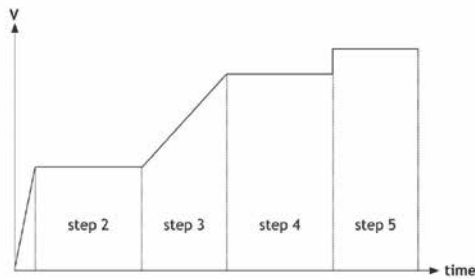

- On screen help in 4 languages
- Real Time Clock
- Various running modes:
 - Simple Mode
 - 9x9 Method Programming Mode
 - Voltage Ramp Mode
 - Timer Mode
- Constant voltage/Constant current/Constant power
- Automatic cross-over
- Automatic recovery after power failure
- Password protection
- Data-logging
- Remote control via open communication protocol
- Safety features:
 - Ground leakage detection
 - Overload protection
 - Smooth voltage rise
 - No load detection
 - Isolated USB communication
- Free software and firmware updates



EV3000 series contains 5 versions. The 3000V and 6000V version have a special low current mode for IEF applications. The IEF mode is for low current applications. The power supply can measure currents as low as 10 microAmps. All Consort power supplies can keep voltage constant at 0 current.



EV3020 (300V, 2000mA):

an excellent choice for blotting, multiple horizontal and vertical gels.

EV3610 (600V, 1000mA):

all round power supply suitable for most tanks and applications

EV3150 (1200V, 500mA):

suitable for higher voltage applications with a need for higher currents

EV3330 (3000V, 200mA):

high voltage with special low current mode

EV3620 (6000V, 100mA):

ultra high voltage with special low current mode

EV3000 series has a firmware upgrade capability and continuous logging with a real time clock. Consort Power Supplies are the most robust, long lasting and durable electrophoresis power supplies in the market.

Specifications depending on model

Power	300 W
Voltage	0-300 V to 0-6000V
Current	0-100 mA to 0-2000mA
Outputs	4
Operating Modes	4
	Simple Mode
	9x9 Method Programming Mode
	Voltage Ramp mode
	Timer Mode (time or Vh)

USB interface

Datalogging

Real Time Clock

Multiple safety features

Warranty

36 months

Made in Belgium

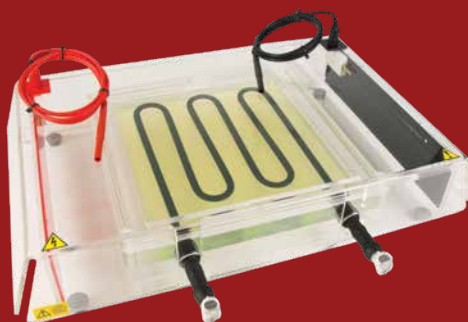

EIEF1100-SYS

Code	Description
EV3020	Power supply, 300 V, 2000 mA, 300 W
EV3610	Power supply, 600 V, 1000 mA, 300 W
EV3150	Power supply, 1200 V, 500 mA, 300 W
EV3330	Power supply, 3000 V, 200 mA, 300 W
EV3620	Power supply, 6000 V, 100 mA, 300 W
ESEQ1200-SYS	Sequencing unit 20x50 cm
EIEF1100-SYS	Isoelectric focusing system, 26x26 cm
→ Supplied with a european mains cord + USB cable	

Specifications

	EV3020	EV3610	EV3150
VOLTAGE	0...300 V	0...600 V	0...1200 V
CURRENT	0...2000 mA	0...1000 mA	0...500 mA
POWER	0...300 W	0...300 W	0...300 W
PARAMETER RANGE	1...100% of full scale	1...100% of full scale	1...100% of full scale
TIMER	0...99:59 h	0...99:59 h	0...99:59 h
VOLT-HOURS	0...99.99 kWh	0...99.99 kWh	0...99.99 kWh
DISPLAY	LCD, 2x16 characters	LCD, 2x16 characters	LCD, 2x16 characters
RESOLUTION	1 V, 1 mA, 1 W	1 V, 1 mA, 1 W	1 V, 1 mA, 1 W
MEASUREMENT RESOLUTION	1 V, 0.1 mA, 0.1 W	1 V, 0.1 mA, 0.1 W	1 V, 0.1 mA, 0.1 W
PROGRAMS	9x9 set of parameters	9x9 set of parameters	9x9 set of parameters
OUTPUTS	4 (4 mm sockets)	4 (4 mm sockets)	4 (4 mm sockets)
MINIMUM LOAD RESISTANCE	5 Ω	15 Ω	70 Ω
NO LOAD DETECTION	✓	✓	✓
GROUND LEAKAGE DETECTION	✓	✓	✓
OVERLOAD DETECTION	✓	✓	✓
COMPUTER CONTROL	✓	✓	✓
PASSWORD PROTECTION	✓	✓	✓
DATA-LOGGING	3600 values	3600 values	3600 values
INTERVAL	1...60 seconds	1...60 seconds	1...60 seconds
USB INTERFACE	✓	✓	✓
AMBIENT TEMPERATURE	0...40°C	0...40°C	0...40°C
RELATIVE HUMIDITY	0...95%, non condensing	0...95%, non condensing	0...95%, non condensing
POWER REQUIREMENTS	210...250 VAC, 50/60 Hz, 360 W 100...125 VAC, 50/60 Hz, 360 W	210...250 VAC, 50/60 Hz, 360 W 100...125 VAC, 50/60 Hz, 360 W	210...250 VAC, 50/60 Hz, 360 W 100...125 VAC, 50/60 Hz, 360 W
DIMENSIONS (WxDxH)	31x26x13 cm	31x26x13 cm	31x26x13 cm
WEIGHT	10 kg	10 kg	10 kg

	EV3330	EV3620
VOLTAGE	0...3000 V	0...6000 V
CURRENT	0...200 mA	0...100 mA
POWER	0...300 W	0...300 W
PARAMETER RANGE	1...100% of full scale	1...100% of full scale
TIMER	0...99:59 h	0...99:59 h
VOLT-HOURS	0...99.99 kWh	0...99.99 kWh
DISPLAY	LCD, 2x16 characters	LCD, 2x16 characters
RESOLUTION	1 V, 1 mA, 1 W	1 V, 1 mA, 1 W
MEASUREMENT RESOLUTION	1 V, 0.1 mA, 0.1 W	1 V, 0.1 mA, 0.1 W
RESOLUTION IEF MODE	1 V, 0.01 mA, 0.01 W	1 V, 0.01 mA, 0.01 W
PROGRAMS	9x9 set of parameters	9x9 set of parameters
OUTPUTS	4 (4 mm sockets)	4 (2 mm sockets)
MINIMUM LOAD RESISTANCE	600 Ω	1200 Ω
NO LOAD DETECTION	✓	✓
GROUND LEAKAGE DETECTION	✓	✓
OVERLOAD DETECTION	✓	✓
COMPUTER CONTROL	✓	✓
PASSWORD PROTECTION	✓	✓
DATA-LOGGING	3600 values	3600 values
INTERVAL	1...60 seconds	1...60 seconds
USB INTERFACE	✓	✓
AMBIENT TEMPERATURE	0...40°C	0...40°C
RELATIVE HUMIDITY	0...95%, non condensing	0...95%, non condensing
POWER REQUIREMENTS	210...250 VAC, 50/60 Hz, 360 W 100...125 VAC, 50/60 Hz, 360 W	210...250 VAC, 50/60 Hz, 360 W 100...125 VAC, 50/60 Hz, 360 W
DIMENSIONS (WxDxH)	31x26x13 cm	31x26x13 cm
WEIGHT	10 kg	10 kg

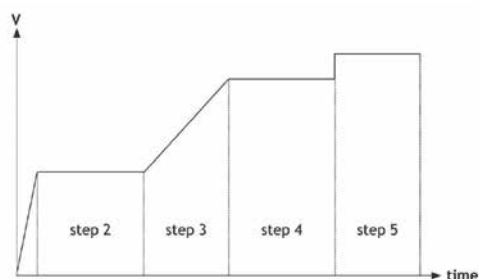

Horizontal Units



- Finger grooves on the tray sides for easy handling
- Wide range of comb configurations
- Selected units available with buffer recirculation capabilities
- Combs specifications clearly marked on each comb
- Advanced casting systems
- UV transmissible gel trays with
 - Built-in fluorescent rulers
 - Multiple comb slots
- High quality 9mm thick rugged acrylic construction
- Interlocking lid
- Protected sockets with permanently attached power cords
- Epoxy sealed electrode connections, resist corrosion and leaks
- Gold plated banana plugs
- Meets or exceeds IEC1010-1 standards



With the EHS3000 series Consort is introducing a new high quality standard for electrophoresis tanks. Every tank is designed and produced with much care for the customer. The tanks are made completely from cast acrylic ensuring a high material quality.

Various features, innovations and details make this tank easy to use, elegant and very durable.



Automatic buffer recirculation (available on selected units)

Reduces detrimental ion and pH gradients in your buffer, providing even migration for long running gels. Hydrogen bubbles created at the cathode carry buffer along a canted recirculation tube, providing a gentle, reliable and self-contained recirculation system that is self-regulating and requires no additional tubing or equipment.



RapidCast™ gel casting technology

Ideal for most small gel units with trays that are approximately equal in width and length. The dimensions of all cast-in-place gel trays are adjusted so that when the tray is placed cross-ways in the gel tank, the gasketed ends of the gel tray fit precisely against the walls of the buffer chamber. This forms a leak-proof seal for quick gel pouring.

Turn tray crossways in the gel base to seal and pour.
Align with the platform to run. No tape! No Leaks! Fast & Efficient.



ExpressCast™ gel casting technology

High throughput / high resolution systems require gel trays too long to fit crossways in the gel tank. For easy tapeless casting with these units, the ExpressCast™ system has been developed. ExpressCast trays incorporate removable gasketed end gates. These end gates fit into slots at both ends of the tray, to form a quick leak-proof seal for gel casting. Because the length of ExpressCast trays is not constrained by the width of the gel unit, these trays can accommodate longer run lengths or more sample capacity.

ExpressCast trays are also compatible with gel units from many other manufacturers.

ExpressCast™ trays include end slots into which fit gasketed end gates, for easy in-tray gel casting. Fit end gates into trays for a quick and leak-proof seal. No tape! No Leaks! Fast & Efficient.

Code	Description
EHS3100-SYS	Mini horizontal unit, gasketed UVT gel tray 7x8 cm + 2 combs (6, 10), RapidCast technology.
EHS3200-SYS	Mini horizontal unit, gasketed UVT gel tray 9x11 cm + 2 combs (10, 14), RapidCast technology.
EHS3300-SYS	Mini horizontal unit, gasketed UVT gel tray 12x14 cm + 2 combs (12, 20), RapidCast technology.
EHS3350-SYS	Mini horizontal unit, gasketed UVT gel tray 12x14 cm + 2 combs (12, 20), RapidCast technology. Buffer Recirculation.
EHS3400-SYS	Wide horizontal unit, UVT gel tray 15x15 cm + end gates + 4 combs (2x 17, 2x34). ExpressCast technology.
EHS3410-SYS	Long horizontal unit, UVT gel tray 15x25 cm + end gates + 4 combs (2x 17, 2x34) + leveling screws + bubble level. ExpressCast technology.
EHS3500-SYS	Wide horizontal unit, UVT gel tray 20x25 cm + end gates + 3 combs (16, 24, 36) + leveling screws + bubble level. ExpressCast technology.
EHS3600-SYS	Wide horizontal unit, UVT gel tray 23x14 cm + end gates + 4 combs (4x 50) + leveling screws + bubble level. ExpressCast technology.
EHS3610-SYS	Maxi horizontal unit, UVT gel tray 23x25 cm + end gates + 4 combs (2x 25, 2x50) + leveling screws + bubble level. ExpressCast technology.
EHS3660-SYS	Maxi horizontal unit, UVT gel tray 23x25 cm + end gates + 4 combs (2x 25, 2x50) + leveling screws + bubble level. ExpressCast technology. Buffer Recirculation.
EHS3620-SYS	Ultra horizontal unit, UVT gel tray 23x40 cm + end gates + 4 combs (2x 25, 2x50) + leveling screws + bubble level. ExpressCast technology.



With the EHS3xxx series Consort is introducing a new high quality standard for electrophoresis tanks. Every tank is designed and produced with much care for the customer. The tanks are made completely from cast acrylic ensuring a high material quality.

Various features, innovations and details make this tank easy to use, elegant and very durable.

Convenient & Versatile

- UV transmissible gel trays with built-in fluorescent rulers.
- Machined finger grooves on the tray sides for easy and sure handling.
- Wide range of comb configurations, including multi-channel capability.
- Selected units available with buffer recirculation capabilities.
- Combs specifications clearly marked on each comb.
- Advanced casting systems for flexibility, convenience and speed.
- All EHS3xxx-series trays feature multiple comb slots, built-in fluorescent rulers and ultra-strong assembly methods for long, reliable service.

Safe & Reliable

- High quality 9mm thick rugged acrylic construction, resists cracking and warping.
- Your safety ensured with interlocking lid, protected sockets and permanently attached power cords.
- Epoxy sealed electrode connections, resist corrosion and leaks.
- Gold plated banana plugs.
- Meets or exceeds IEC1010-1 standards.

RapidCast™ gel casting technology

The RapidCast™ system is ideal for most small gel units with trays that are approximately equal in width and length. The dimensions of all cast-in-place gel trays are adjusted so that when the tray is placed crossways in the gel tank, the gasketed ends of the gel tray fit precisely against the walls of the buffer chamber. This forms a leak-proof seal for quick gel pouring. This system can also be used with RapidCast casters, for casting outside the buffer tank. A long-lived silicone rubber gasket ensures a reliable seal thru many gel castings and side grooves on all RapidCast trays provide for easy handling.

RapidCast™ Technology uses trays with incorporated end gaskets, to easily cast gels in the gel unit base. Turn tray crossways in the gel base to seal and pour. Align with the platform to run. No tape! No Leaks! Fast & Efficient.

ExpressCast™ gel casting technology

High throughput / high resolution systems require gel trays too long to fit crossways in the gel tank. For easy tapeless casting with these units, the ExpressCast™ system has been developed. ExpressCast trays incorporate removable gasketed end gates. These end gates fit into slots at both ends of the tray, to form a quick leak-proof seal for gel casting. Because the length of ExpressCast trays is not constrained by the width of the gel unit, these trays can accommodate longer run lengths or more sample capacity.

ExpressCast trays are also compatible with gel units from many other manufacturers.

ExpressCast™ trays include end slots into which fit gasketed end gates, for easy in-tray gel casting. Fit end gates into trays for a quick and leak-proof seal. No tape! No Leaks! Fast & Efficient.

Integrated buffer recirculation (available on selected units)

Automatic buffer recirculation reduces detrimental ion and pH gradients in your buffer, providing even migration for long running gels. Hydrogen bubbles created at the cathode carry buffer along a canted recirculation tube, providing a gentle, reliable and self-contained recirculation system that is self-regulating and requires no additional tubing or equipment.



Gel dimensions	7x8 cm
Buffer volume	400ml
Gel volume (at 0.5cm)	28ml
Sample Capacity	24
Comb Slots	2
Sample runs	1 or 2
Unit Dimensions	12x17.6x9.5 cm
Running condition	60V at 5V/cm
UV transmissible gel tray	
RapidCast	
Warranty	36 months
Recommended power supply	
EV2650	



● Description

The EHS3100 mini gel systems are ideal for quick resolution of analytes from PCR, RE digestion, ligation and other common laboratory reactions.

Features

RapidCast™ gel casting technology.

Heavy duty lower buffer chamber and Interlock safety lid with attached leads.

Buffer chamber with color coded, sealed platinum electrodes and non-slip rubber feet.

UV transmissible gel tray with long-life silicone gaskets, built-in fluorescent ruler and 2 comb slots.

Safety cover with attached retractable-sheathed power cords.

Wide range of combs and accessories available.

● Ordering codes

Code	Description
EHS3100-SYS	Mini horizontal unit gasketed UVT gel tray 7x8 cm 1 comb: 6 sample, 1.5mm 1 comb: 10 sample, 1.5mm

Combs

Code	Description	Sample volume
EHS3100-C5-1.0	1 mm thick, 5 sample	25 µl
EHS3100-C6-1.0	1 mm thick, 6 sample	20 µl
EHS3100-C8-1.0	1 mm thick, 8 sample	14 µl
EHS3100-C10-1.0	1 mm thick, 10 sample	11 µl
EHS3100-C12-1.0	1 mm thick, 12 sample	8 µl
EHS3100-C5-1.5	1.5 mm thick, 5 sample	38 µl
EHS3100-C6-1.5	1.5 mm thick, 6 sample	31 µl
EHS3100-C8-1.5	1.5 mm thick, 8 sample	22 µl
EHS3100-C10-1.5	1.5 mm thick, 10 sample	16 µl
EHS3100-C12-1.5	1.5 mm thick, 12 sample	12 µl

Preparative Combs

Code	Description	Sample volume
EHS1100-PREP	1.5mm, preparative	193 µl

Replacement parts & Accessories

Code	Description
EHS3100-TRAY	Gasketed UVT gel tray 7x8 cm
EHS3100-GASKET	Replacement gasket (set of 2)
EHS3100-CAST	Multiple Casting Chamber (holds 3 UVT trays)
EHS3100-CAST3T	Multiple Casting Chamber including 3 UVT trays 7x8 cm

Gel dimensions	9x11 cm
Buffer volume	600ml
Gel volume (at 0.5cm)	50ml
Sample Capacity	36
Comb Slots	2
Equidistant sample runs	1 or 2
Unit Dimensions	15x22x9.5 cm
Running condition	90V at 5V/cm
UV transmissible gel tray	
RapidCast	
Warranty	36 months

Recommended power supply
EV2650
EV2310



● Description

The EHS3200 is a versatile mini-gel unit that offers a little more run length and capacity for restriction fragment and PCR amplicon analysis.

Features

RapidCast™ gel casting technology.

Heavy duty lower buffer chamber and Interlock safety lid with attached leads.

Buffer chamber with color coded, sealed platinum electrodes and non-slip rubber feet.

UV transmissible gel tray with long-life silicone gaskets, built-in fluorescent ruler and 2 comb slots.

Safety cover with attached retractable-sheathed power cords.

Wide range of combs and accessories available.

● Ordering codes

Complete System

Code	Description
EHS3200-SYS	Mini horizontal unit gasketed UVT gel tray 9x11 cm 1 comb: 10 sample, 1.5mm 1 comb: 14 sample, 1.5mm

Combs

Code	Description	Sample volume
EHS3200-C5-1.0	1 mm thick, 5 sample	25 µl
EHS3200-C8-1.0	1 mm thick, 8 sample	20 µl
EHS3200-C10-1.0	1 mm thick, 10 sample	14 µl
EHS3200-C12-1.0	1 mm thick, 12 sample	11 µl
EHS3200-C14-1.0	1 mm thick, 14 sample	8 µl
EHS3200-C5-1.5	1.5 mm thick, 5 sample	38 µl
EHS3200-C8-1.5	1.5 mm thick, 8 sample	31 µl
EHS3200-C10-1.5	1.5 mm thick, 10 sample	22 µl
EHS3200-C12-1.5	1.5 mm thick, 12 sample	16 µl
EHS3200-C14-1.5	1.5 mm thick, 14 sample	12 µl

Replacement parts & Accessories

Code	Description
EHS3200-TRAY	Gasketed UVT gel tray 9x11 cm
EHS3200-GASKET	Replacement gasket (set of 2)
EHS3200-CAST	Multiple Casting Chamber (holds 3 UVT trays)
EHS3200-CAST3T	Multiple Casting Chamber including 3 UVT trays 7x8 cm

Gel dimensions	12x14cm
Buffer volume	800ml
Gel volume (at 0.5cm)	84ml
Sample Capacity	100
Comb Slots	4
Equidistant sample runs	1 or 2
Unit Dimensions	18x24.5x9.5 cm
Running condition	115V at 5V/cm
RapidCast	
UV transmissible gel tray	
Automatic Buffer Recirculation (EHS3350 only)	
Warranty	36 months

Recommended power supply
EV2650
EV2310



EHS3350-SYS

● Description

The EHS3300 is our most popular mini-gel unit. A combination of outstanding versatility and value make it an ideal personal gel device. Two unit configurations are available including the new EHS3350 which includes integrated automatic buffer recirculation for improved performance. All systems feature RapidCast™ casting system for tapeless casting in the buffer chamber base or in optional casting frame.

Features

- RapidCast™ gel casting technology.
- Heavy duty lower buffer chamber and Interlock safety lid with attached leads.
- Buffer chamber with color coded, sealed platinum electrodes and non-slip rubber feet.
- UV transmissible gel tray with long-life silicone gaskets, built-in fluorescent ruler and 2 comb slots.
- Safety cover with attached retractable-sheathed power cords.
- Wide range of combs and accessories available.



EHS3350-SYS

● Ordering codes

Complete System

Code	Description
EHS3300-SYS	Mini horizontal unit gasketed UVT gel tray 12x14 cm 1 comb: 12 sample, 1.5mm 1 comb: 20 sample, 1.5mm
EHS3350-SYS	Mini horizontal unit with automatic buffer recirculation gasketed UVT gel tray 12x14 cm 1 comb: 12 sample, 1.5mm 1 comb: 20 sample, 1.5mm



EHS3300-SYS

Combs

Code	Description	Sample volume
EHS3300-C8-1.0	1 mm thick, 8 sample	25 µl
EHS3300-C16-1.0	1 mm thick, 16 sample	20 µl
EHS3300-C20-1.0	1 mm thick, 20 sample	14 µl
EHS3300-C24-1.0	1 mm thick, 24 sample	11 µl
EHS3300-C8-1.5	1.5 mm thick, 8 sample	38 µl
EHS3300-C16-1.5	1.5 mm thick, 16 sample	31 µl
EHS3300-C20-1.5	1.5 mm thick, 20 sample	22 µl
EHS3300-C24-1.5	1.5 mm thick, 24 sample	16 µl

Microtiter Combs

Code	Description	Sample volume
EHS3300-CMT9-1.0	1 mm thick, 9 sample MC	16 µl
EHS3300-CMT12-1.0	1 mm thick, 12 sample MC	6 µl
EHS3300-CMT25-1.0	1 mm thick, 25 sample MC	6 µl
EHS3300-CMT9-1.5	1.5 mm thick, 9 sample MC	24 µl
EHS3300-CMT12-1.5	1.5 mm thick, 12 sample MC	9 µl
EHS3300-CMT25-1.5	1.5 mm thick, 25 sample MC	6 µl

Replacement parts & Accessories

Code	Description
EHS3300-TRAY	Gasketed UVT gel tray 12x14 cm
EHS3300-GASKET	Replacement gasket (set of 2)
EHS3300-CAST	Multiple Casting Chamber (holds 3 UVT trays)
EHS3300-CAST3T	Multiple Casting Chamber including 3 UVT trays 7x8 cm

Gel dimensions	15x15cm
Buffer volume	1020ml
Gel volume (at 0.5cm)	112ml
Sample Capacity	160
Comb Slots	6
Equidistant sample runs	1, 2, 3 or 4
Unit Dimensions	21x26x9.5 cm
Running condition	120V at 5V/cm
UV transmissible gel tray	
ExpressCast	
Warranty	36 months

Recommended power supply
EV2650
EV2310



● Description

The EHS3400 ExpressCast™ system is an ideal midi-gel unit for moderate thru-put sample analysis. This system features the ExpressCast gel casting system for quick, tape-free gel casting.

Features

ExpressCast™ gel casting technology.

Heavy duty lower buffer chamber and Interlock safety lid with attached leads.

Buffer chamber with color coded, sealed platinum electrodes and non-slip rubber feet.

UV transmissible gel tray built-in fluorescent ruler and 6 comb slots.

Safety cover with attached retractable-sheathed power cords.

Wide range of combs and accessories available.

● Ordering codes

Complete System

Code	Description
EHS3400-SYS	Wide horizontal unit UVT gel tray 15x15 cm , end gates 2 combs: 17 sample, 1.5mm 2 combs: 34 sample, 1.5mm

Combs

Code	Description	Sample volume
EHS3400-C10-1.0	1 mm thick, 10 sample	25 µl
EHS3400-C20-1.0	1 mm thick, 20 sample	20 µl
EHS3400-C40-1.0	1 mm thick, 40 sample	14 µl
EHS3400-C10-1.5	1.5 mm thick, 10 sample	38 µl
EHS3400-C20-1.5	1.5 mm thick, 20 sample	31 µl
EHS3400-C40-1.5	1.5 mm thick, 40 sample	22 µl

Microtiter Combs

Code	Description	Sample volume
EHS3400-CMT17-1.0	1 mm thick, 17 sample MC	16 µl
EHS3400-CMT34-1.0	1 mm thick, 34 sample MC	6 µl
EHS3400-CMT17-1.5	1.5 mm thick, 17 sample MC	24 µl
EHS3400-CMT34-1.5	1.5 mm thick, 34 sample MC	9 µl

Replacement parts & Accessories

Code	Description
EHS3400-TRAY	UVT gel tray, 15x15 cm, with gasketed end gates
EHS3400-DAM	Casting Dam for 15cm Wide Gel Trays
EHS3400-GATE	End Gates, includes gasket (set of 2)
EHS3400-GASKET	Replacement Gasket (set of 2)

Gel dimensions	15x25cm
Buffer volume	1850ml
Gel volume (at 0.5cm)	188ml
Sample Capacity	112
Comb Slots	6
Equidistant sample runs	1, 2, 3 or 4
Run lengths	5.5, 7.5, 11.4 and 23,2 cm
Unit Dimensions	23.5x37.5x10.5 cm
Running condition	170V at 5V/cm
UV transmissible gel tray	
ExpressCast	
Warranty	36 months

Recommended power supply
EV2650
EV2310



● Description

The EHS3410 is a long run length mini-gel system. With a maximum run length of 25cm, the unit can provide high resolution of complex analytes. The EHS3410 features the ExpressCast gel casting system for quick, tape-free gel casting. The unit is manufactured with a levelling base that includes a built-in level and 3-point levelling using nylon screws for convenient level adjustment.

Features:

ExpressCast™ gel casting technology.

Heavy duty lower buffer chamber and Interlock safety lid with attached leads.

Buffer chamber with color coded, sealed platinum electrodes and non-slip rubber feet.

UV transmissible gel tray with 6 comb slots.

Safety cover with attached retractable-sheathed power cords.

Wide range of combs and accessories available.

● Ordering codes

Complete System

Code	Description
EHS3410-SYS	Long horizontal unit UVT gel tray 15x25 cm , end gates 2 combs: 17 sample, 1.5mm 2 combs: 34 sample, 1.5mm

Combs

Code	Description	Sample volume
EHS3400-C10-1.0	1 mm thick, 10 sample	25 µl
EHS3400-C20-1.0	1 mm thick, 20 sample	20 µl
EHS3400-C40-1.0	1 mm thick, 40 sample	14 µl
EHS3400-C10-1.5	1.5 mm thick, 10 sample	38 µl
EHS3400-C20-1.5	1.5 mm thick, 20 sample	31 µl
EHS3400-C40-1.5	1.5 mm thick, 40 sample	22 µl

Microtiter Combs

Code	Description	Sample volume
EHS3400-CMT17-1.0	1 mm thick, 17 sample MC	16 µl
EHS3400-CMT34-1.0	1 mm thick, 34 sample MC	6 µl
EHS3400-CMT17-1.5	1.5 mm thick, 17 sample MC	24 µl
EHS3400-CMT34-1.5	1.5 mm thick, 34 sample MC	9 µl

Replacement parts & Accessories

Code	Description
EHS3400-TRAY	UVT gel tray, 15x15 cm, with gasketed end gates
EHS3410-TRAY20	UVT gel tray, 15x20 cm, with gasketed end gates
EHS3410-TRAY25	UVT gel tray, 15x25 cm , with gasketed end gates
EHS3400-DAM	Casting Dam for 15cm Wide Gel Trays
EHS3400-GATE	End Gates, includes gasket (set of 2)
EHS3400-GASKET	Replacement Gasket (set of 2)

Gel dimensions	20x25cm
Buffer volume	1850ml
Gel volume (at 0.5cm)	250ml
Sample Capacity	168
Comb Slots	6
Equidistant sample runs	1, 2, 3 or 4
Run lengths	5.5, 7.5, 11.4 and 23,2 cm
Unit Dimensions	29x37.5x10.5 cm
Running condition	170V at 5V/cm
UV transmissible gel tray	
ExpressCast	
Warranty	36 months
Recommended power supply	
EV2650	
EV3150	



● Description

The EHS3500 can accommodate a large range of sample and run length combinations for the ultimate in versatility. The unit is manufactured with a levelling base that includes a built-in level and 3-point levelling using nylon screws for convenient level adjustment.

Features

- ExpressCast™ gel casting technology.
- Heavy duty lower buffer chamber and Interlock safety lid with attached leads.
- Buffer chamber with color coded, sealed platinum electrodes and non-slip rubber feet.
- UV transmissible gel tray with 6 comb slots.
- Safety cover with attached retractable-sheathed power cords.

● Ordering codes

Complete System

Code	Description
EHS3500-SYS	Wide long horizontal unit UVT gel tray 20x25 cm, end gates levelling screws, bubble level 1 comb: 16 sample, 1.5mm 1 comb: 24 sample, 1.5mm 1 comb: 36 sample, 1.5mm

Combs

Code	Description	Sample volume
EHS3500-C8-1.0	1 mm thick, 8 sample	25 µl
EHS3500-C12-1.0	1 mm thick, 12 sample	20 µl
EHS3500-C16-1.0	1 mm thick, 16 sample	14 µl
EHS3500-C20-1.0	1 mm thick, 20 sample	38 µl
EHS3500-C24-1.0	1 mm thick, 24 sample	31 µl
EHS3500-C28-1.0	1 mm thick, 28 sample	22 µl
EHS3500-C32-1.0	1 mm thick, 32 sample	22 µl
EHS3500-C36-1.0	1 mm thick, 36 sample	22 µl
EHS3500-C8-1.5	1.5 mm thick, 8 sample	25 µl
EHS3500-C12-1.5	1.5 mm thick, 12 sample	20 µl
EHS3500-C16-1.5	1.5 mm thick, 16 sample	14 µl
EHS3500-C20-1.5	1.5 mm thick, 20 sample	38 µl
EHS3500-C24-1.5	1.5 mm thick, 24 sample	31 µl
EHS3500-C28-1.5	1.5 mm thick, 28 sample	22 µl
EHS3500-C32-1.5	1.5 mm thick, 32 sample	22 µl
EHS3500-C36-1.5	1.5 mm thick, 36 sample	22 µl

Microtiter Combs

Code	Description	Sample volume
EHS3500-CMT18-1.0	1 mm thick, 18 sample MC	16 µl
EHS3500-CMT21-1.0	1 mm thick, 21 sample MC	6 µl
EHS3500-CMT42-1.0	1 mm thick, 42 sample MC	6 µl
EHS3500-CMT18-1.5	1.5 mm thick, 18 sample MC	24 µl
EHS3500-CMT21-1.5	1.5 mm thick, 21 sample MC	9 µl
EHS3500-CMT42-1.5	1.5 mm thick, 42 sample MC	9 µl

Replacement parts & Accessories

Code	Description
EHS3500-TRAY	UVT gel tray, 20x25 cm, with gasketed end gates
EHS3500-DAM	Casting Dam for 20cm Wide Gel Trays
EHS3500-GATE	End Gates, includes gasket (set of 2)
EHS3500-GASKET	Replacement Gasket (set of 2)

Gel dimensions	23.5x14cm
Buffer volume	1700
Gel volume (at 0.5cm)	161ml
Sample Capacity	200
Comb Slots	4
Unit Dimensions	32x26x10.5 cm
Running condition	120V at 5V/cm
UV transmissible gel tray	
ExpressCast	
Warranty	36 months

Recommended power supply
EV2650
EV3150



● Description

The EHS3500 is our “double-wide” midi gel unit. Ideal for quick analysis of larger quantities of samples. The unit is manufactured with a levelling base that includes a built-in level and 3-point levelling using nylon screws for convenient level adjustment.

Features

ExpressCast™ gel casting technology.

Heavy duty lower buffer chamber and Interlock safety lid with attached leads.

Buffer chamber with color coded, sealed platinum electrodes and non-slip rubber feet.

UV transmissible gel tray and 4 comb slots.

Safety cover with attached retractable-sheathed power cords.

● Ordering codes

Complete System

Code	Description
EHS3600-SYS	Wide horizontal unit UVT gel tray 23.5x14 cm, end gates levelling screws, bubble level 4 combs: 50 sample, 1.5mm

Microtiter Combs

Code	Description	Sample volume
EHS3600-CMT25-1.0	1 mm thick, 25 sample MC	16 µl
EHS3600-CMT26-1.0	1 mm thick, 26 sample MC	6 µl
EHS3600-CMT40-1.0	1 mm thick, 50 sample MC	6 µl
EHS3600-CMT25-1.5	1.5 mm thick, 25 sample MC	24 µl
EHS3600-CMT26-1.5	1.5 mm thick, 26 sample MC	9 µl
EHS3600-CMT50-1.5	1.5 mm thick, 50 sample MC	9 µl

Replacement parts & Accessories

Code	Description
EHS3600-TRAY	UVT gel tray, 23.5x14 cm, with gasketed end gates
EHS3600-DAM	Casting Dam for 20cm Wide Gel Trays
EHS3600-GATE	End Gates, includes gasket (set of 2)
EHS3600-GASKET	Replacement Gasket (set of 2)

Gel dimensions	23.5x25cm 23.5x14cm
Buffer volume	1700
Gel volume (at 0.5cm)	161ml
Sample Capacity	500
Comb Slots	14
Equidistant sample runs	1, 2, 3, 4, 5 or 10
Run lengths	2, 4.4, 5.5, 7.5, 11.4 & 23,2 cm
Unit Dimensions	32x26x10.5 cm
Running condition	170V at 5V/cm
UV transmissible gel tray	
ExpressCast	
Automatic Buffer Recirculation (EHS3660 only)	
Warranty	36 months

Recommended power supply
EV2650
EV3150



EHS3660-SYS

● Description

The EHS3610 and EHS3660 system is capable of processing large numbers of samples quickly and efficiently. Two unit configurations are available including the new EHS3660 which includes integrated automatic buffer recirculation for improved performance. The unit is manufactured with a levelling base that includes a built-in level and 3-point levelling using nylon screws for convenient level adjustment.

Features

- ExpressCast™ gel casting technology.
- Heavy duty lower buffer chamber and Interlock safety lid with attached leads.
- Buffer chamber with color coded, sealed platinum electrodes and non-slip rubber feet.
- UV transmissible gel tray with 14 comb slots.
- Safety cover with attached retractable-sheathed power cords.

● Ordering codes

Complete System

Code	Description
EHS3610-SYS	Maxi horizontal unit UVT gel tray 23x25 cm, end gates levelling screws, bubble level 2 combs: 25 sample, 1.5mm 2 combs: 50 sample. 1.5mm
EHS3660-SYS	Maxi horizontal unit UVT gel tray 23x25 cm, end gates levelling screws, bubble level 2 combs: 25 sample, 1.5mm 2 combs: 50 sample. 1.5mm

Microtiter Combs

Code	Description	Sample volume
EHS3600-CMT25-1.0	1 mm thick, 25 sample MC	16 µl
EHS3600-CMT26-1.0	1 mm thick, 26 sample MC	6 µl
EHS3600-CMT40-1.0	1 mm thick, 50 sample MC	6 µl
EHS3600-CMT25-1.5	1.5 mm thick, 25 sample MC	24 µl
EHS3600-CMT26-1.5	1.5 mm thick, 26 sample MC	9 µl
EHS3600-CMT50-1.5	1.5 mm thick, 50 sample MC	9 µl

Replacement parts & Accessories

Code	Description
EHS3600-TRAY	UVT gel tray, 23.5x14 cm, with gasketed end gates
EHS3610-TRAY	UVT gel tray, 23.5x25 cm, with gasketed end gates
EHS3600-DAM	Casting Dam for 20cm Wide Gel Trays
EHS3600-GATE	End Gates, includes gasket (set of 2)
EHS3600-GASKET	Replacement Gasket (set of 2)



EHS3610-SYS

Gel dimensions	23.5x40cm 23.5x25cm 23.5x14cm
Buffer volume	1700
Gel volume (at 0.5cm)	161ml
Sample Capacity	600
Comb Slots	12
Equidistant sample runs	1, 2, 3, 4, 6 or 12
Run lengths	3, 6.3, 8.9, 12.9, 19.5 & 35 cm
Unit Dimensions	32x26x10.5 cm
Running condition	120V at 5V/cm
UV transmissible gel tray	
ExpressCast	
Buffer recirculation ports	
Warranty	36 months

Recommended power supply
EV2650, EV3150



● Description

The EHS3620 can handle both very large numbers of samples, and long runs as well, providing both high resolution and high through-put. The EHS3620 device includes buffer recirculation ports for connection to external buffer recirculation devices, and features Galileo's ExpressCast™ casting system for in-tray tapeless casting. The unit is manufactured with a levelling base that includes a built-in level and 3-point levelling using nylon screws for convenient level adjustment.

Features

ExpressCast™ gel casting technology.

Heavy duty lower buffer chamber and Interlock safety lid with attached leads.

Buffer chamber with color coded, sealed platinum electrodes and non-slip rubber feet.

UV transmissible gel tray with 12 comb slots.

Safety cover with attached retractable-sheathed power cords.

Wide range of combs and accessories available.

● Ordering codes

Complete System

Code	Description
EHS3620-SYS	Wide horizontal unit UVT gel tray 23x40 cm, end gates levelling screws, bubble level 2 combs: 25 sample, 1.5mm 2 combs: 50 sample, 1.5mm

Microtiter Combs

Code	Description	Sample volume
EHS3600-CMT25-1.0	1 mm thick, 25 sample MC	16 µl
EHS3600-CMT26-1.0	1 mm thick, 26 sample MC	6 µl
EHS3600-CMT40-1.0	1 mm thick, 50 sample MC	6 µl
EHS3600-CMT25-1.5	1.5 mm thick, 25 sample MC	24 µl
EHS3600-CMT26-1.5	1.5 mm thick, 26 sample MC	9 µl
EHS3600-CMT50-1.5	1.5 mm thick, 50 sample MC	9 µl

Replacement parts & Accessories

Code	Description
EHS3600-TRAY	UVT gel tray, 23.5x14 cm, with gasketed end gates
EHS3610-TRAY	UVT gel tray, 23.5x25 cm, with gasketed end gates
EHS3620-TRAY	UVT gel tray, 23.5x40 cm, with gasketed end gates
EHS3600-DAM	Casting Dam for 20cm Wide Gel Trays
EHS3600-GATE	End Gates, includes gasket (set of 2)
EHS3600-GASKET	Replacement Gasket (set of 2)

About Horizontal Electrophoresis

Gel concentration

The range of fragment sizes to be separated will determine the choice of agarose concentration for a gel. Typical agarose concentration is 0.5% to 3.0%. For large DNA fragments low-percentage gels are required, while for small DNA fragments, high-percentage gels are recommended. Weak gels (0.5% agarose) should be electrophoresed at low temperatures (e.g. -4°C). Agarose gels of 0.75% to 1.0%, for routine electrophoresis, are recommended for a wide range of separations (0.15 to 15 kb). 2...4% agarose gels are usually selected for PCR fragment resolution. If the gel has to be subsequently photographed, thin gels (2 to 3 mm) with low-percentage agarose are better than thick or high-percentage gels. The latter produce increased opacity and autofluorescence.

Electrophoresis buffer

TAE buffer provides optimal resolution of fragments >4 kb in length, while for 0.1 to 3 kb fragments, TBE buffer should be selected. TBE has both a higher buffering capacity and lower conductivity than TAE and therefore should be used for high-voltage electrophoresis. Additionally, TBE buffer generates less heat than TAE at an equivalent voltage and does not allow a significant pH drift. Note: because of its lower buffering capacity, TAE should be circulated or mixed from time to time for full-length electrophoresis, especially at higher voltages.

Temperature influence

Electrophoresis at high voltages produces heat. Additionally, high-conductivity buffers such as TAE generate more heat than low-conductivity buffers. Care should be taken in agarose gel electrophoresis with voltages greater than 175 V, as heat build up can generate gel artifacts such as S-shaped migration fronts, and in extended electrophoresis runs, can even melt the agarose gel. With high voltage electrophoresis, the use of low-melting-point agarose gels should be avoided.

RNA mobility

Either before or during electrophoresis, RNA should be denatured. For example, RNA fragments which have denatured with glyoxal and dimethyl sulphoxide can be separated on neutral agarose gels, or RNA can be fractionated on agarose gels containing methylmercuric hydroxide or formaldehyde. RNA samples usually require longer runs or buffers that are easily depleted, so it is necessary to circulate the buffer. Northern analyses should not normally be run on a mini gel tank.

Separation performance

Gel concentration, running buffer, voltage, temperature, conformation, and the presence of ethidium bromide all affect separation results. To establish progress of double-stranded DNA, ethidium bromide (0.5 $\mu\text{g}/\text{ml}$) is often added to running buffer. The dye's fluorescence properties allows the band to be visualised under a UV lamp. However, ethidium bromide may slow the DNA migration rate by approx. 15%. As an alternative, after electrophoresis, the gel may be stained in an ethidium bromide solution (0.5 $\mu\text{g}/\text{ml}$ H₂O) for 15 to 60 minutes and then viewed or photographed on a UV trans-illuminator.

Enhancing resolution

2 x TAE buffer can be used in units with low buffer volume to enhance resolution during extended runs.

EHS1000 series



Horizontal units



● Overview

Low cost

Injection moulded construction

Durable, leak-proof environment for complete safety and long life

Cassette type electrodes

Inexpensive, easy to replace. Made of 99.99% corrosion resistant, pure platinum.

Multiple gel trays

Gel size and sample number requirements can be exactly matched in each unit, with the option of additional gel tray sizes.

This eliminates the need for multiple gel tanks for changes in gel size or application. With no indentations or casting gate grooves in the tray to interfere with sample progression, traditional tape casting can be used, should this be preferred.

Easy to use

Leak proof "Plug and Go" casting dams allow gels to be rapidly cast externally while the tank remains in use for electrophoresis.

Gel dimensions	10x 8 cm
Buffer volume	50ml
Sample Capacity	40
Unit Dimensions	15x15x4 cm

Recommended power supply
EV2650



● Description

The mini rapid horizontal unit is a completely self contained system designed for quick checks of samples. Gel casting, running and analysis are all performed in the same ultra compact unit.

Buffer and gel volumes have been kept to a minimum and the parallel electrode arrangement allows ultra efficient current transfer, enabling resolution to be completed within 30 minutes.

The UV transparent base allows direct viewing on a UV Transilluminator with no need for time consuming transfer and potential gel damage.

Dual comb slots allow the loading of up to 40 samples per gel while multichannel pipette compatible combs further enhance the speed and convenience.

Complete System

Code	Description
EHS1050-SYS	Mini rapid unit dams 2 combs: 8 sample, 1.5mm

Combs

Code	Description	Sample volume
EHS1050-C16-1.0	1 mm thick, 16 sample	15 µl

Replacement parts & Accessories

Code	Description
EHS1050-GATE	Casting dams (pk/2)

Gel dimensions	7x7cm 7x10 cm
Buffer volume	225ml
Sample Capacity	64
Unit Dimensions	21x9x9 cm
Warranty	12 months

Recommended power supply
EV2650
EV2310

EHS1100 is the smallest unit in the range, designed for low to medium numbers of samples. The small gel size maximises run economy but does not compromise versatility. This compact unit is capable of resolving up to 64 different samples.

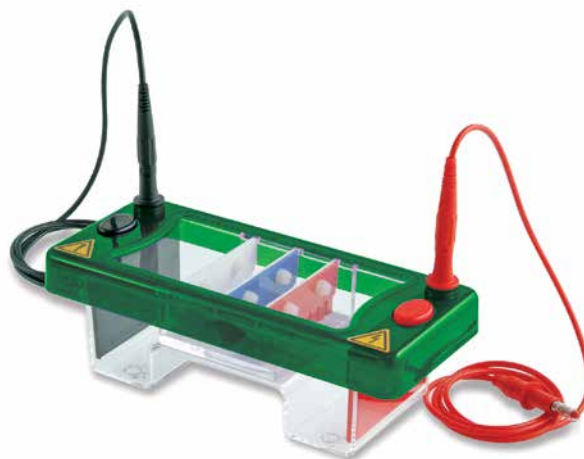

Complete System

Code	Description
EHS1100-SYS	Mini horizontal unit, 7x7 cm casting tray, 7x10 cm casting tray loading guides, dams 2 combs: 8 sample, 1mm
EHS1101-SYS	Mini horizontal unit, 7x7 cm casting tray loading guides, dams 2 combs: 8 sample, 1 mm
EHS1102-SYS	Mini horizontal unit, 7x10 cm casting tray loading guides, dams 2 combs: 8 sample, 1 mm

Combs

Code	Description	Sample volume
EHS1100-C8-1.0	1 mm thick, 8 sample	25 µl
EHS1100-C10-1.0	1 mm thick, 10 sample	18 µl
EHS1100-C16-1.0	1 mm thick, 16 sample	10 µl
EHS1100-C8-1.5	1.5 mm thick, 8 sample	37 µl
EHS1100-C10-1.5	1.5 mm thick, 10 sample	27 µl
EHS1100-C16-1.5	1.5 mm thick, 16 sample	14 µl

Replacement parts & Accessories

Code	Description
EHS1100-TRAY7	Gel casting tray, 7x7 cm
EHS1100-TRAY10	Gel casting tray, 7x10 cm
EHS1100-GATE	Casting dams, pk/2
EHS1100-POS	Positive electrode cassette (red)
EHS1100-NEG	Negative electrode cassette (black)
EHS1100-LG	Adhesive loading guides
EHS1100-BUFSAVE	Buffer saving blocks, pk/2 (saves 100 ml of buffer)
EHS1100-COOL	Cool-pack and platform
EHS1100-SCOOP	Gel scoop, 7 cm

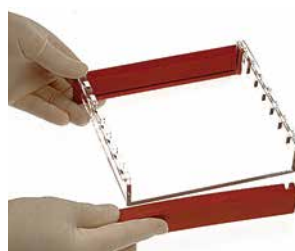

Casting dams allow gels to be rapidly cast externally while the unit is in use for gel running¹

Gel dimensions	10x7cm 10x10 cm
Buffer volume	300ml
Sample Capacity	100
Unit Dimensions	22x12.5x9 cm
Warranty	12 months

Recommended power supply

EV2650

EV2310

EHS1200 allows more samples to be resolved per gel without a significant increase in buffer or gel volumes. 100 samples per gel can be resolved making this unit ideal for those routinely checking medium numbers of samples over short to medium gel run lengths.

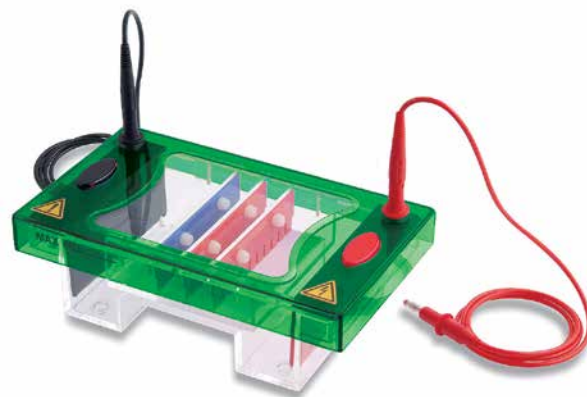

● Ordering codes

Code	Description
EHS1200-SYS	Midi horizontal unit, 10x7 cm casting tray, 10x10 cm casting tray loading guides, dams 2 combs: 16 sample, 1 mm
EHS1201-SYS	Midi horizontal unit, 10x7 cm casting tray loading guides, dams 2 combs: 16 sample, 1 mm
EHS1202-SYS	Midi horizontal unit, 10x10 cm casting tray loading guides, dams 2 combs: 16 sample, 1 mm

Combs

Code	Description	Sample volume
EHS1200-C8-1.0	1 mm thick, 8 sample	41 µl
EHS1200-C12-1.0	1 mm thick, 12 sample	23 µl
EHS1200-C16-1.0	1 mm thick, 16 sample	16 µl
EHS1200-C25-1.0	1 mm thick, 25 sample	10 µl
EHS1200-C8-1.5	1.5 mm thick, 8 sample	61 µl
EHS1200-C12-1.5	1.5 mm thick, 12 sample	34 µl
EHS1200-C16-1.5	1.5 mm thick, 16 sample	24 µl
EHS1200-C25-1.5	1.5 mm thick, 25 sample	15 µl

Replacement parts & Accessories

Code	Description
EHS1200-TRAY7	Gel casting tray, 10x7 cm
EHS1200-TRAY10	Gel casting tray, 10x10 cm
EHS1200-GATE	Casting dams, pk/2
EHS1200-POS	Positive electrode cassette (red)
EHS1200-NEG	Negative electrode cassette (black)
EHS1200-LG	Adhesive loading guides
EHS1200-BUFSAVE	Buffer saving blocks, pk/2 (saves 100 ml of buffer)
EHS1200-COOL	Cool-pack and platform
EHS1200-SCOOP	Gel scoop, 10 cm



Loading guides allow easy well identification and sample loading

Gel dimensions	15x7cm 15x10 cm 15x15 cm
Buffer volume	500ml
Sample Capacity	210
Unit Dimensions	26.5x17.5x9 cm
Warranty	12 months

Recommended power supply

EV2650
EV2310

EHS1300 offers a wide degree of versatility with three tray options. Up to 210 samples to be resolved per gel. The 15 cm total run length allows restriction fragment or other close MW sample bands to be easily separated and identified.



● Ordering codes

Code	Description
EHS1300-SYS	Midi-plus horizontal unit, 15x7 casting trays, 15x10 casting trays, 15x15 cm gel casting trays loading guides, dams, 2 combs: 20 sample, 1 mm thick
EHS1301-SYS	Midi-plus horizontal unit, 15x7 cm casting tray loading guides, dams, 2 combs: 20 sample, 1 mm thick
EHS1302-SYS	Midi-plus horizontal unit, 15x10 cm casting tray loading guides, dams, 2 combs: 20 sample, 1 mm thick
EHS1303-SYS	Midi-plus horizontal unit, 15x15 cm casting tray loading guides, dams, 2 combs: 20 sample, 1 mm thick

Combs

Code	Description	Sample volume
EHS1300-C10-1.0	1 mm thick, 10 sample	45 µl
EHS1300-C12-1.0	1 mm thick, 12 sample	41 µl
EHS1300-C20-1.0	1 mm thick, 20 sample	21 µl
EHS1300-C35-1.0	1 mm thick, 35 sample	10 µl
EHS1300-C10-1.5	1.5 mm thick, 10 sample	68 µl
EHS1300-C12-1.5	1.5 mm thick, 12 sample	61 µl
EHS1300-C20-1.5	1.5 mm thick, 20 sample	32 µl
EHS1300-C35-1.5	1.5 mm thick, 35 sample	15 µl

Replacement parts & Accessories

Code	Description
EHS1300-TRAY7	Gel casting tray, 15x7 cm
EHS1300-TRAY10	Gel casting tray, 15x10 cm
EHS1300-TRAY15	Gel casting tray, 15x15 cm
EHS1300-GATE	Casting dams, pk/2
EHS1300-POS	Positive electrode cassette (red)
EHS1300-NEG	Negative electrode cassette (black)
EHS1300-LG	Adhesive loading guides
EHS1300-BUFSAVE	Buffer saving blocks, pk/2 (saves 190 ml of buffer)
EHS1300-COOL	Cool-pack and platform
EHS1300-SCOOP	Gel scoop, 15 cm

Gel dimensions	20x10cm 20x20 cm 20x25 cm
Buffer volume	1200ml
Sample Capacity	550
Unit Dimensions	39.5x23x9 cm
Warranty	12 months

Recommended power supply

EV2310

EV2650

EHS1400 is primarily designed for resolution of high numbers of samples such as from cloning or PCR. It allows ultra high-resolution separations over extended runs. Tray sizes correspond to standard blotter sizes. Multichannel pipette compatible combs facilitate speed loading of up to 550 samples per gel.



● Ordering codes

Code	Description
EHS1400-SYS	Maxi horizontal unit, 20x10 gel casting tray, 20x20 cm casting trays loading guides, dams, 2 combs: 20 sample, 1 mm thick
EHS1401-SYS	Maxi horizontal unit + 20x10 cm casting tray loading guides, dams, 2 combs: 20 sample, 1 mm thick
EHS1402-SYS	Maxi horizontal unit + 20x20 cm casting tray loading guides, dams, 2 combs: 20 sample, 1 mm thick
EHS1403-SYS	Maxi Horizontal unit + 20x25 cm casting tray loading guides, dams, 2 combs: 20 sample, 1 mm thick

Combs

Code	Description	Sample volume
EHS1400-C10-1.0	1 mm thick, 10 sample	72 µl
EHS1400-C16-1.0	1 mm thick, 16 sample	41 µl
EHS1400-C25-1.0	1 mm thick, 25 sample	21 µl
EHS1400-C30-1.0	1 mm thick, 30 sample	17 µl
EHS1400-C36-1.0	1 mm thick, 36 sample	14 µl
EHS1400-C50-1.0	1 mm thick, 50 sample	10 µl
EHS1400-C10-1.5	1.5 mm thick, 10 sample	108 µl
EHS1400-C16-1.5	1.5 mm thick, 16 sample	61 µl
EHS1400-C25-1.5	1.5 mm thick, 25 sample	32 µl
EHS1400-C30-1.5	1.5 mm thick, 30 sample	26 µl
EHS1400-C36-1.5	1.5 mm thick, 36 sample	22 µl
EHS1400-C50-1.5	1.5 mm thick, 50 sample	16 µl

Replacement parts & Accessories

Code	Description
EHS1400-TRAY10	Gel casting tray, 20x10 cm
EHS1400-TRAY20	Gel casting tray, 20x20 cm
EHS1400-TRAY25	Gel casting tray, 20x25 cm
EHS1400-GATE	Casting dams, pk/2
EHS1400-POS	Positive electrode cassette (red)
EHS1400-NEG	Negative electrode cassette (black)
EHS1400-LG	Adhesive loading guides
EHS1400-BUFSAVE	Buffer saving blocks, pk/2 (saves 450 ml of buffer)
EHS1400-COOL	Cool-pack and platform
EHS1400-SCOOP	Gel scoop, 20 cm

Gel dimensions	26x16 cm 26x24 cm 26x32 cm
Buffer volume	1400 ml
Sample Capacity	672
Unit Dimensions	50x28x9 cm
Warranty	12 months

Recommended power supply

EV2650

EV3150

Designed for rapid screening of very large numbers of clonal or PCR samples, EHS1500 has a 672 maximum sample capacity per gel. This allows loading and analysis of seven 96 well format micro titre plates.

The large gel run length allows resolution of samples over a long distance for separation of complex sample bands. Buffer recirculation ports are included as standard to allow enhanced resolution over extended runs.



● Ordering codes

Code	Description
EHS1500-SYS	Maxi-plus horizontal unit, 26x16 casting trays, 26x24 casting trays, 26x32 cm casting trays loading guides, dams, 6 combs: 28 sample, 1 mm thick
EHS1501-SYS	Maxi-plus horizontal unit, 26x16 cm gel casting tray loading guides, dams, 6 combs: 28 sample, 1 mm thick
EHS1502-SYS	Maxi-plus horizontal unit + 26x24 cm gel casting tray loading guides, dams, 6 combs: 28 sample, 1 mm thick
EHS1503-SYS	Maxi-plus horizontal unit + 26x32 cm gel casting tray loading guides, dams, 6 combs: 28 sample, 1 mm thick

Microtiter Combs

Code	Description	
EHS1500-CMT28-1.0	1 mm thick, 28 sample MC	34 µl
EHS1500-CMT56-1.0	1 mm thick, 56 sample MC	14 µl
EHS1500-CMT28-1.5	1.5 mm thick, 28 sample MC	51 µl
EHS1500-CMT56-1.5	1.5 mm thick, 56 sample MC	20 µl

Replacement parts & Accessories

Code	Description
EHS1500-TRAY16	Gel casting tray, 26x16 cm
EHS1500-TRAY24	Gel casting tray, 26x24 cm
EHS1500-TRAY32	Gel casting tray, 26x32 cm
EHS1500-TAPE	Gel tray sealing tape, 65 m x 25.4 mm
EHS1500-POS	Positive electrode cassette (red)
EHS1500-NEG	Negative electrode cassette (black)
EHS1500-LG	Adhesive loading guides
EHS1500-BUFSAVE	Buffer saving blocks, pk/2 (saves 625 ml of buffer)
EHS1500-COOL	Cool-pack and platform
EHS1500-SCOOP	Gel scoop, 26 cm

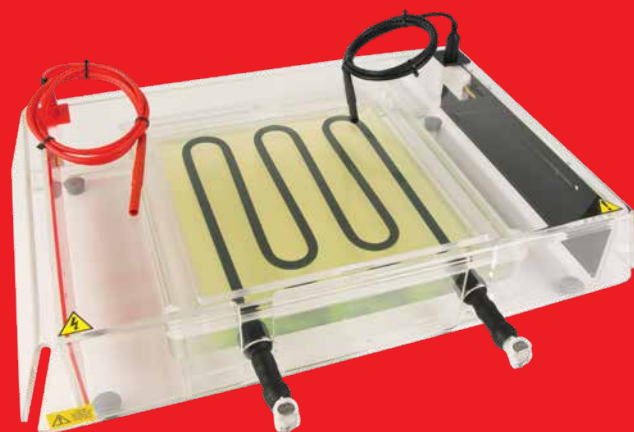

The IEF mode is for low current applications. The power supply can measure currents as low as 10 microAmps. All Consort power supplies can keep voltage constant at 0 current.

EV3330 (3000V, 300mA):
high voltage with special low current mode (IEF-mode)

EV3620 (6000V, 150mA):
ultra high voltage with special low current mode (IEF-mode)

EV3000 series has a firmware upgrade capability and continuous logging with a real time clock.

Consort Power Supplies are the most robust, long lasting and durable electrophoresis power supplies in the market.

This IEF system has been designed to perform all flat bed IEF techniques, including wick-based electrophoresis with horizontal and hand-cast IEF gels, and focusing with IPG strips.

The unit includes a large cooling platform which offers increased strip capacity and active gel area. Uniform cooling of the platform is achieved using a large ceramic plate that may be connected to any standard chiller via quick-fit connectors for enhanced gel or strip cooling. An optional rehydration tray is also available for overnight rehydration of up to twelve IPG strips before use.

Unit dimensions (WxDxH): 55x35x10 cm
Recommended power supply: EV3330, EV3620



Code	Description
EIEF1100-SYS	Isoelectric focusing system, 26x26 cm
EIEF1100-POS	Replacement positive electrode cassette (red)
EIEF1100-NEG	Replacement negative electrode cassette (black)
EIEF1100-GLASS	Replacement glass platform
EIEF1100-FRAME	Replacement electrode frame
EIEF1100-REHYD	Rehydration tray
EV3330	Power supply, 3000 V, 200 mA, 300 W
EV3620	Power supply, 6000 V, 100 mA, 300 W

● Relation between Voltage, Current, Power and Resistance

Ohms law: Resistance (Ohm) = Voltage (V) / Current (A)

Resistance is, in a certain environment (temperature, humidity,...) constant. This means that current follows voltage variations and visa versa. It is impossible to force a power supply to deliver a certain current AND a certain voltage.

The resistance of an electrophoresis unit depends on its size, gel thickness, amount of buffer, buffer conductivity and temperature. This resistance will normally decrease in time due to a slowly increasing temperature. Electrophoresis units which have a resistance below the minimum load resistance of a power supply will trigger an alarm! Read the output voltage and current during a run to measure the resistance and use above formula to calculate the value.

Power (W) = Voltage (V) x Current (A)

This means that the total power depends on both voltage and current. But since current depends on resistance it's impossible to force to generate a certain power. The only thing that can be done is limit the power supply to generate a certain power.

● Behaviour of a power supply

When RUN is pressed, the internal generator will start building up the high voltage at the output terminals while voltage and current are constantly measured and power is calculated. When one of the pre-set parameters is exceeded, the generator stops rising the Voltage and will keep that parameter constant.

Constant voltage

To keep the voltage constant, program the desired voltage and a higher current and power than the maximum expected values:

Current > Voltage / Resistance

Power > Voltage x Current

Constant current

To keep the current constant, program the desired current and a higher voltage and power than the maximum expected values:

Voltage > Current x Resistance

Power > Voltage x Current

Constant power

To keep the power constant, program the desired power and a higher voltage and current than the maximum expected values:

Voltage > Current x Resistance

Current > Voltage / Resistance

FAQ

Why are my output values different from those of a similar experiment?

Either your programmed parameters are not equal to those described or the resistance of your electrophoresis unit is different (see above). It cannot be due to e.g. an other model of power supply as the relations between Voltage, Current, Power and Resistance are monitored in the same way by any instrument (the electrical laws cannot be disregarded!).

What about connecting more than one unit to the same power supply?

The outlets being in parallel each electrophoresis unit will be supplied with exactly the same voltage. However, current and power may differ due to differences between them even when exactly the same model, gel, buffers, etc... are used. Therefore, it is recommended to run several electrophoresis units only in the constant voltage mode on the same power supply.

Vertical Units





Our EVS3xxx vertical systems allow for fine resolution of protein or nucleic acid fragments on one or two acrylamide gels (PAGE). PAGE separation offers the superior resolution necessary to separate native or denatured proteins and nucleic acids in applications such as SSCP or dinucleotide repeat analysis using western blotting and also for automated protein sequencing analysis.

All three models in the EV3xxx series incorporate inspired design features and exceptional manufacturing methods that ensure dependable performance over years of continuous use. A comprehensive offering of combs and accessories, plus the compatibility of the EVS3100 with most commercially available pre-cast mini gels, ensures maximum system utility to exceed the separation demands of most research laboratories.

High Performance

- Exceptional resolution.
- Rugged trouble-free construction.
- All units run one or two gels.
- 10x10 unit compatible with most pre-cast gels.
- Rapid and efficient cast-in-place gel casting system.
- Unique electrode configuration for straight, rapid runs.
- Efficient temperature regulation prevents band distortion.

Convenient & Versatile

- Upper buffer chamber acts as heat sink to provide uniform temperature across gel and reduce smiling.
- Units available with ports for attachment to external cooling systems.
- Wide range of comb configurations, including multi-channel capability.
- Reliable clamping system for no-leak casting and running.
- Optional gel caster for pre-casting gels while system is in use.
- Wide range of combs and accessories.

Safe & Reliable

- High quality, rugged acrylic construction, resists cracking and warping.
- Your safety ensured with interlocking lid.
- Corrosion resistant contacts and gold plugs for years of reliable service.
- Meets or exceeds IEC1010-1 standards.

Outstanding Features Ensure Trouble-Free Use

- Robust Acrylic Construction Stands up to Daily Usage without Breakage, Warping or Leakage
- Rugged, Spring-Loaded Clamp Mechanism, Alignment Pins & Hollow Gaskets Guarantee Reliable Leak-Proof Gel Installation
- Precision Glass Plates Provide Exceptional Flatness and Finished Edges to Ensure Uniform Separation
- Casting Base Enables Casting Directly on the Upper Buffer Chamber Obviating Need to Move Gels once Polymerized
- Intelligent Design Results in Exceptional Resolution
- Electrode Configuration Assures Uniform Field, Straight Lanes and Rapid Runs – Saving Time and Improving Data Generation Rate
- Proximal Upper Buffer Chamber Exploits Specific Heat of Aqueous Buffer to Provide Uniform Temperature and No Smiling
- Efficient Water Cooling System, Available on All Systems, Prevent Band Distortion.
- Optional Notched Alumina Plates available for the mini 10 cm x 10cm unit Enhance Heat Dissipation.

Wide Variety of Options Maximize Product Versatility

- Devices available for three Gel Sizes, Including the wide mini EVS3200 that Accommodate 72 Samples, Supporting Most PAGE Applications.
- Optional Additional Upper Buffer Chambers Allow for Simultaneous Use of the Twin Systems – Improving Data Output Rate.
- Non-Cooled 10cm x 10cm & 20cm x 10cm Upper Buffer Chambers Available.
- Wide Selection of Combs, plus Glass and Blocking Plates Available for All Units.
- Units are Compatible with Pre-cast Acrylamide Gels from Most Manufacturers and Vertical Agarose (VAGE) Separation.

Gel dimensions	10x10cm
Buffer volume	400
Gel volume (at 0.5cm)	6-15ml
Sample Capacity	30
Unit Dimensions	17x14x12 cm
Running condition	15-35mA/gel
Integrated Water Cooling System	
Spring-Loaded Clamp Mechanism	
Warranty	36 months

Recommended power supply
EV2650
EV3150



● Description

The EVS3100 is compatible with most pre-cast gels and can run one or two gels and has an integrated water cooling system.

Features

- High Performance.
- Exceptional resolution.
- Rugged trouble-free construction.
- Rapid and efficient gel casting system.
- Unique electrode configuration for straight, rapid runs.
- Efficient temperature regulation prevents band distortion.
- Wide range of combs and accessories available.

● Ordering codes

Complete System

Code	Description
EVS3100-SYS	Mini vertical unit 2 sets of plain glass plates 1 set of notched glass plates 2 sets of 0.8mm spacers 1 casting base 1 extra replacement gasket for upper buffer chamber 1 dummy plate 1 spacer tool 2 combs: 10 sample, 0.8 mm thick

Combs

Code	Description	Sample volume
EVS3100-C6-0.8	0.8 mm thick, 6 sample	142 µl
EVS3100-C10-0.8	0.8 mm thick, 10 sample	73 µl
EVS3100-C12-0.8	0.8 mm thick, 12 sample	55 µl
EVS3100-C6-1.5	1.5 mm thick, 6 sample	266 µl
EVS3100-C10-1.5	1.5 mm thick, 10 sample	136 µl
EVS3100-C12-1.5	1.5 mm thick, 12 sample	103 µl

Microtiter Combs

Code	Description	Sample volume
EVS3100-CMT9-0.8	0.8 mm thick, 9 sample MC	84 µl
EVS3100-CMT9-1.5	1.5 mm thick, 9 sample MC	160 µl

Replacement parts & Accessories

Code	Description
EVS3100-BASE	Gel casting base, 10 cm
EVS3100-BASEGASKET	Replacement gasket for casting base
EVS3100-UBDGASKET	Replacement gasket for upper buffer chamber
EVS3100-DUMMY	Dummy plate
EVS3100-NGLASS	Notched glass plates, 10x10 cm, 2.4 mm thick (set of 2)
EVS3100-GLASS	Glass plates, 10x10 cm, 2.4 mm thick (set of 2)
EVS3100-ALU	Notched aluminium backer plate for improved cooling
EVS3100-SP-0.8	Spacers, 0.8 mm thick (set of 2)
EVS3100-SP-1.5	Spacers, 1.5 mm thick (set of 2)

Gel dimensions	20x10cm
Buffer volume	800
Gel volume (at 0.5cm)	15-30ml
Sample Capacity	72
Unit Dimensions	28x15x13 cm
Running condition	15-45mA/gel
Integrated Water Cooling System	
Spring-Loaded Clamp Mechanism	
Warranty	36 months

Recommended power supply
EV2650
EV3150



● Description

The EVS3200 is a wide format system, accommodates large sample numbers and has an integrated water cooling system.

Features

- High Performance.
- Runs one or two gels.
- Rugged trouble-free construction.
- Unique electrode configuration for straight, rapid runs.
- Efficient temperature regulation prevents band distortion.
- Wide range of combs and accessories available.
- Rapid and efficient gel casting system.

● Ordering codes

Complete System

Code	Description
EVS3200-SYS	Wide vertical unit 2 sets of plain glass plates 2 set of notched glass plates 4 sets of 0.8mm spacers 1 casting base 1 extra replacement gasket for upper buffer chamber 1 dummy plate 1 spacer tool 2 combs: 15 sample, 0.8 mm thick 2 combs: 20 sample, 0.8 mm thick

Combs

Code	Description	Sample volume
EVS3200-C10-0.8	0.8 mm thick, 10 sample	239 µl
EVS3200-C15-0.8	0.8 mm thick, 15 sample	144 µl
EVS3200-C20-0.8	0.8 mm thick, 20 sample	97 µl
EVS3200-C25-0.8	0.8 mm thick, 25 sample	69 µl
EVS3200-C10-1.5	1.5 mm thick, 10 sample	449 µl
EVS3200-C15-1.5	1.5 mm thick, 15 sample	271 µl
EVS3200-C20-1.5	1.5 mm thick, 20 sample	182 µl
EVS3200-C25-1.5	1.5 mm thick, 25 sample	129 µl

Microtiter Combs

Code	Description	Sample volume
EVS3200-CMT18-0.8	0.8 mm thick, 18 sample MC	78 µl
EVS3200-CMT36-1.5	1.5 mm thick, 36 sample MC	156 µl
EVS3200-CMT18-0.8	0.8 mm thick, 18 sample MC	32 µl
EVS3200-CMT36-1.5	1.5 mm thick, 36 sample MC	64 µl

Replacement parts & Accessories

Code	Description
EVS3200-BASE	Gel casting base, 20 cm
EVS3200-BASEGASKET	Replacement gasket for casting base
EVS3200-UBDGASKET	Replacement gasket for upper buffer chamber
EVS3200-DUMMY	Dummy plate
EVS3200-NGLASS	Notched glass plates, 20x10 cm, 3.2 mm thick (set of 2)
EVS3200-GLASS	Glass plates, 20x10 cm, 3.2 mm thick (set of 2)
EVS3200-ALU	Notched aluminium backer plate for improved cooling
EVS3200-SP-0.8	Spacers, 0.8 mm thick (set of 2)
EVS3200-SP-1.5	Spacers, 1.5 mm thick (set of 2)

Gel dimensions	20x20cm
Buffer volume	1300
Gel volume (at 0.5cm)	25-49ml
Sample Capacity	50
Unit Dimensions	30x24x16 cm
Running condition	15-75mA/gel
Integrated Water Cooling System	
Spring-Loaded Clamp Mechanism	
Warranty	36 months

Recommended power supply
EV2650
EV3150



● Description

The EVS3300 is a large format system, accommodates large sample numbers and has an integrated water cooling system.

Features

- High Performance.
- Runs one or two gels.
- Rugged trouble-free construction.
- Unique electrode configuration for straight, rapid runs.
- Efficient temperature regulation prevents band distortion.
- Wide range of combs and accessories available.
- Rapid and efficient gel casting system.

● Ordering codes

Complete System

Code	Description
EVS3300-SYS	Maxi vertical unit 2 sets of plain glass plates 2 set of notched glass plates 4 sets of 0.8mm spacers 1 casting base 1 extra replacement gasket for upper buffer chamber 1 dummy plate 1 spacer tool 2 combs: 15 sample, 0.8 mm thick 2 combs: 20 sample, 0.8 mm thick

Combs

Code	Description	Sample volume
EVS3300-C10-0.8	0.8 mm thick, 10 sample	239 µl
EVS3300-C15-0.8	0.8 mm thick, 15 sample	144 µl
EVS3300-C20-0.8	0.8 mm thick, 20 sample	97 µl
EVS3300-C25-0.8	0.8 mm thick, 25 sample	69 µl
EVS3300-C10-1.5	1.5 mm thick, 10 sample	449 µl
EVS3300-C15-1.5	1.5 mm thick, 15 sample	271 µl
EVS3300-C20-1.5	1.5 mm thick, 20 sample	182 µl
EVS3300-C25-1.5	1.5 mm thick, 25 sample	129 µl

Replacement parts & Accessories

Code	Description
EVS3300-BASE	Gel casting base, 20 cm
EVS3300-BASEGASKET	Replacement gasket for casting base
EVS3300-UBDGASKET	Replacement gasket for upper buffer chamber
EVS3300-DUMMY	Dummy plate
EVS3300-NGLASS	Notched glass plates, 20x20 cm, 3.2 mm thick (set of 2)
EVS3300-GLASS	Glass plates, 20x20 cm, 3.2 mm thick (set of 2)
EVS3300-ALU	Notched aluminium backer plate for improved cooling
EVS3300-SP-0.8	Spacers, 0.8 mm thick (set of 2)
EVS3300-SP-1.5	Spacers, 1.5 mm thick (set of 2)

Cassette size	9 x 9
Cassette capacity	4
Buffer Volume (ml)	1300
Unit Dimensions	13x15x15 cm
Recommended voltage	150V
Warranty	36 months
Recommended power supply	EV2310

Outstanding Features Ensure Trouble-Free Use

- Robust Acrylic Construction Stands up to Daily Usage without Breakage, Warping or Leakage
- Gold Plated Electrodes, Corrosion Free and Rated
- Safe up to 1,000 volts
- Safety Cover with attached Power Cords Assures Safety and Prevents Reverse Orientation of Electric Field

Intelligent Design Results in Exceptional Resolution

- Efficient Water Cooled Base
- Color Coded Cassettes Obviate Accidental Sample Loss



Description

The EVS3100-BLOT Tank Electro-Blotter is designed to rapidly transfer nucleic acid or protein fragments from up to four polyacrylamide gels at one time to nitrocellulose, nylon or PVDF membranes. The color-coded cassettes allow for easy assembly of transfer sandwich and error-free transfer.

The large buffer capacity allows for high current output for the transfer of high molecular weight proteins while integral cooling permits high voltages and extended transfers. System is compatible with transfer membranes and blotting paper from all suppliers.

This tank style electroblotter provides reliable and efficient transfer of a wide range of protein compounds from acrylamide gels. Up to four gels can be transferred simultaneously. Platinum grid style electrodes and robust construction assure even and complete molecular transfer and long service life. System is supplied complete with power leads and four blotting cassettes.

Ordering codes

Code	Description
EVS3100-BLOT	Mini Tank Blotter (10x10cm) with 4 cassettes
EVS3100-CASSETTE	Transfer Cassette with Pads
EVS3100-FIBREPAD	Replacement Blotting Pads, 4 per pack



Cassette size	18 x 20
Cassette capacity	2
Buffer Volume (ml)	4000
Unit Dimensions	22x12.5x9 cm
Recommended voltage	150V
Warranty	36 months
Recommended power supply	EV3150

Outstanding Features Ensure Trouble Free Use

- Robust Acrylic Construction Stands up to Daily Usage without Breakage, Warping or Leakage
- Gold Plated Electrodes, Corrosion Free and Rated
- Safe up to 1,000 volts
- Safety Cover with attached Power Cords Assures Safety and Prevents Reverse Orientation of Electric Field

Intelligent Design Results in Exceptional Resolution

- Efficient Water Cooled Base
- Color Coded Cassettes Obviate Accidental Sample Loss

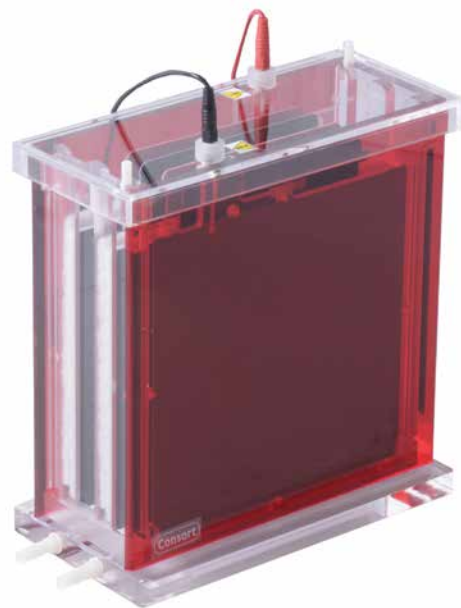

Description

The EVS3300-BLOT Tank ElectroBlotter is designed to rapidly transfer nucleic acid or protein fragments from up to four polyacrylamide gels at one time to nitrocellulose, nylon or PVDF membranes. The color-coded cassettes allow for easy assembly of transfer sandwich and error free transfer.

The large buffer capacity allows for high current output for the transfer of high molecular weight proteins while integral cooling permits high voltages and extended transfers. System is compatible with transfer membranes and blotting paper from all suppliers.

This tank style electroblotter provides reliable and efficient transfer of a wide range of protein compounds from acrylamide gels. Up to four gels can be transferred simultaneously. Platinum grid style electrodes and robust construction assure even and complete molecular transfer and long service life. System is supplied complete with power leads and four blotting cassettes.

Ordering codes

Code	Description
EVS3300-BLOT	Maxi Tank Blotter (20x20cm) with 2 cassettes
EVS3100-CASSETTE	Transfer Cassette with Pads
EVS3100-FIBREPAD	Replacement Blotting Pads, 4 per pack



- Quick & Efficient
- Convenient & Versatile
- Safe & Reliable

Quick transfer times make these systems ideal for the rapid and efficient transfer of nucleic acids and proteins from agarose or acrylamide gels.

Solid plate style electrodes assure even pressure and complete molecular transfer.

Galileo semi-dry electroblotters will accommodate most pre-cast gels, and for many larger format pre-cast gels, once the stacking area of the gel is removed the "working" area will also fit easily into the devices. Since only the transfer "sandwich" of gel, membrane and blotting papers must be kept wet, much less buffer is required than traditional tank transfer systems.

Interlocking safety lid prevents reverse orientation of electric filed. High quality plate electrodes (stainless steel cathode and platinum anode) and gold plated components assure long, trouble-free performance. System is supplied complete with power leads and a sample pack of our ultra-pure cotton fiber filter paper.



Code	Description
ESDB3100	Semi Dry Electroblotter, 11x11cm blotting area
ESDB3200	Semi Dry Electroblotter, 21x21cm blotting area
EV2310	Power supply, 300 V, 1000 mA, 150 W
EV3020	Power supply, 300 V, 2000 mA, 300 W

About Vertical Electrophoresis

Preventing leaking gels

The two most important things to be aware of when casting gels using the caster systems are:

- that the glass plates have been inserted into the casting or gel running module on a flat surface.
- that the spacers are flush with the bottom edges of the glass plates.

Perfect alignment of spacers can be guaranteed using the new glass plates with bonded spacers.

Overcome polymerisation problems

If you are experiencing problems obtaining good polymerisation adjacent to spacers and combs then this can be overcome by pre-soaking the combs and spacers in distilled water or a 10% solution of ammonium persulphate.

Avoiding over-tightening

Over-tightening the cam pins on the casting systems is a common cause of problems when using these units. Cams should only be tightened just until appreciable pressure is felt.

Extracting the tube gel

Tube gel electrophoresis can be difficult because of problems with extracting the tube gel from the capillary tube. The tube gel is best extracted by gently pipetting liquid behind the tube gel and then catching it in the Gel extraction platform.

Enhance transfer

If the gel blot sandwich is too thick, this may bow the cassette causing loss of contact between gel and membrane resulting in poor transfer. The thickness of the blot can be lessened by removing the fibre pad on the non-membrane side of the blot.

EVS1000 series

Vertical units

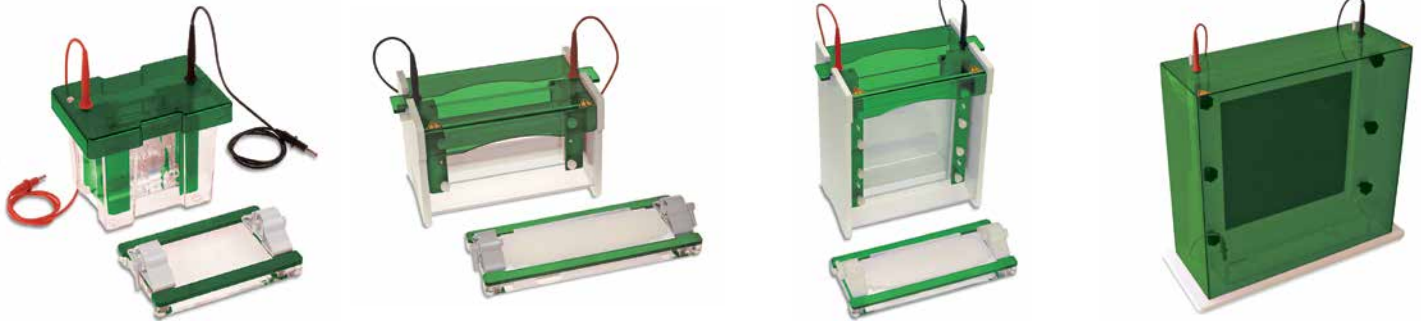

● Overview

Low cost

Injection moulded construction

Durable, leak-proof environment for complete safety and long life.

Easy to use

Leak proof "Plug and Go" casting dams allow gels to be rapidly cast externally while the tank remains in use for electrophoresis.

Plate dimensions	10x10 cm
Gel dimensions	7.5x8 cm
Number of gels	1 to 4
Buffer volume	250 ml to 1200 ml
Sample Capacity	80 (20 per gel)
Unit Dimensions	19x13x15 cm
Warranty	12 months

Recommended power supply

EV1450

EV2310

EVS1100 is constructed using the latest injection moulding manufacturing techniques. This gives a high quality, low cost product with unsurpassed finish, durability and strength.

The unit incorporates a sealing system which is compatible with all major types of 8x10 cm and 10x10 cm pre-cast gel. Runs up to four 1 mm thick gels. Gel casting and running utilise the same insert, no transfer of glass plates during gel casting is necessary. The insert allowing very rapid set up of both hand cast and pre-cast gels. Reversible gasket for use with Bio-Rad 'non-eared' or short glass plates. Accessory electro-blotting and tube gel modules are available which use the same outer tank and lid.

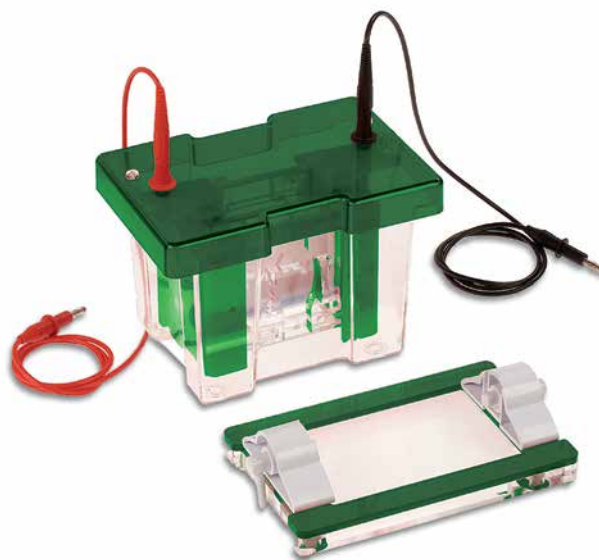

● Ordering codes

Code	Description
EVS1100-SYS	Mini vertical unit, 2 sets of glass plates with bonded 1 mm thick spacers cooling pack, dummy plate, casting base 2 combs: 12 sample, 1 mm thick, 12 samples

Combs

Code	Description	Sample volume
EVS1100-C5-1.0	1 mm thick, 5 sample	100 µl
EVS1100-C9-1.0	1 mm thick, 9 sample	50 µl
EVS1100-C10-1.0	1 mm thick, 10 sample	40 µl
EVS1100-C12-1.0	1 mm thick, 12 sample	35 µl
EVS1100-C20-1.0	1 mm thick, 20 sample	20 µl
EVS1100-C5-1.5	1.5 mm thick, 5 sample	140 µl
EVS1100-C9-1.5	1.5 mm thick, 9 sample	70 µl
EVS1100-C10-1.5	1.5 mm thick, 10 sample	60 µl
EVS1100-C12-1.5	1.5 mm thick, 12 sample	50 µl
EVS1100-C20-1.5	1.5 mm thick, 20 sample	30 µl

Replacement parts & Accessories

Code	Description
EVS1100-BASE	Gel casting base, 10 cm
EVS1100-SILMAT	Replacement silicone mat for gel casting base, 10 cm
EVS1100-GELINSERT	Inner running module
EVS1100-COOL	Mini cooling pack
EVS1100-NGLASS	Notched glass plates, 10x10 cm, 2 mm thick, pk/2
EVS1100-GLASS	Glass plates, 10x10 cm, 2 mm thick, pk/2
EVS1100-GLASS-SP-1	Glass plates, 10x10 cm, + 1 mm bonded spacers, pk/2
EVS1100-GLASS-SP-1.5	Glass plates, 10x10 cm, + 1.5 mm bonded spacers, pk/2
EVS1100-DUMMY	Dummy plate, 10x10 cm
EVS1100-SP-1.0	Spacers, 1 mm thick, 10 cm, pk/2
EVS1100-SP-1.5	Spacers, 1.5 mm thick, 10 cm, pk/2

Plate dimensions	20x10 cm
Gel dimensions	18x8 cm
Number of gels	1 to 4
Buffer volume	600 ml to 2800 ml
Sample Capacity	192 (48 per gel)
Unit Dimensions	26x16x16 cm
Warranty	12 months

Recommended power supply

EV2310

EV2650

EVS1200 allows double the number of samples to be resolved as the mini unit. This allows consistency of sample comparison on a single gel and is designed for those with greater than 20 samples to compare and resolve. Simple set up using ultra soft silicone seals guarantees trouble free glass plate loading and gel casting. Dual gaskets on the gel running insert along with notched and plain glass plates ensure leak proof gel running. Rapid set up cooling retains resolution in extended separations and also saves on buffer volume. 4 mm thick glass plates prevent breakage and have bonded spacers for convenience.



● Ordering codes

Code	Description
EVS1200-SYS	Mini-wide vertical unit, 2 sets of glass plates with bonded 1 mm thick spacers cooling pack, dummy plate, casting base 2 combs: 12 sample, 1 mm thick, 24 samples

Combs

Code	Description	Sample volume
EVS1300-C5-1.0	1 mm thick, 5 sample	200 µl
EVS1300-C10-1.0	1 mm thick, 10 sample	100 µl
EVS1300-C24-1.0	1 mm thick, 24 sample	40 µl
EVS1300-C30-1.0	1 mm thick, 30 sample	35 µl
EVS1300-C48-1.0	1 mm thick, 48 sample	20 µl
EVS1300-C5-1.5	1.5 mm thick, 5 sample	320 µl
EVS1300-C10-1.5	1.5 mm thick, 10 sample	160 µl
EVS1300-C24-1.5	1.5 mm thick, 24 sample	60 µl
EVS1300-C30-1.5	1.5 mm thick, 30 sample	50 µl
EVS1300-C48-1.5	1.5 mm thick, 48 sample	30 µl

Replacement parts & Accessories

Code	Description
EVS1300-BASE	Gel casting base, 20 cm
EVS1300-SILMAT	Replacement silicone mat for gel casting base, 20 cm
EVS1200-GELINSERT	Inner running module
EVS1300-COOL	Maxi cooling pack
EVS1200-NGLASS	Notched glass plates, 20x10 cm, 4 mm thick, pk/2
EVS1200-GLASS	Glass plates, 20x10 cm, 4 mm thick, pk/2
EVS1200-GLASS-SP-1.0	Glass plates, 20x10 cm, + 1 mm bonded spacers, pk/2
EVS1200-GLASS-SP-1.5	Glass plates, 20x10 cm, + 1.5 mm bonded spacers, pk/2
EVS1200-DUMMY	Dummy plate, 20x10 cm
EVS1100-SP-1.0	Spacers, 1 mm thick, 10 cm, pk/2
EVS1100-SP-1.5	Spacers, 1.5 mm thick, 10 cm, pk/2
EPT50	Replacement platinum wire, 0.2 mm thick, 50 cm

Plate dimensions	20x20 cm
Gel dimensions	16x17.5 cm
Number of gels	1 to 4
Buffer volume	1200 ml to 5600 ml
Sample Capacity	192 (48 per gel)
Unit Dimensions	30x18x27 cm
Warranty	12 months

Recommended power supply

EV2650
EV3150
EV3020

EVS1300 is designed to perform a variety of separations, including first- and second-dimension SDS-PAGE, native, preparative, gradient and high-resolution nucleic acid electrophoresis, plus capillary tube gel IEF and electro-blotting.

By introducing innovative, new vertical leak-free casting with vertical screw-pin technology only four screws are now necessary to secure as many 20x20 cm gels. Glass plates compress gently against a flat, level gasket to prevent current leakage from the inner buffer chamber during electrophoresis.

Detachable inner cooling coil connects to the laboratory water supply or a recirculating chiller to provide uniform, smile-free electrophoresis, while allowing runs to be performed at higher voltage. 4 mm thick glass plates reduce breakage and have bonded spacers for added convenience. Prep combs can be used to maximize sample loading and recovery. Accessory electro-blotting and tube gel modules are available which use the same outer tank and lid.

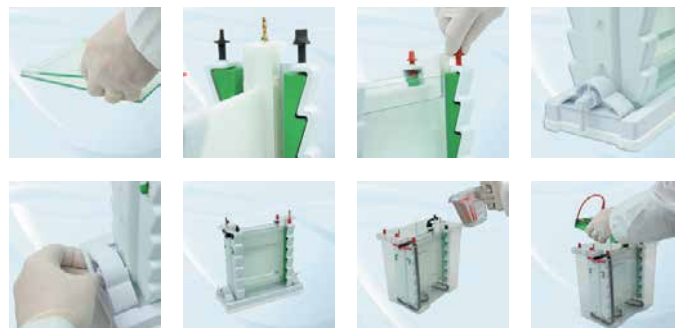

● Ordering codes

Code	Description
EVS1300-SYS	Maxi vertical unit, 2 sets of glass plates with bonded 1 mm thick spacers cooling coil, dummy plate, casting base, 2 combs: 24 sample, 1 mm thick

Combs

Code	Description	Sample volume
EVS1300-C5-1.0	1 mm thick, 5 sample	200 µl
EVS1300-C10-1.0	1 mm thick, 10 sample	100 µl
EVS1300-C24-1.0	1 mm thick, 24 sample	40 µl
EVS1300-C30-1.0	1 mm thick, 30 sample	35 µl
EVS1300-C48-1.0	1 mm thick, 48 sample	20 µl
EVS1300-C5-1.5	1.5 mm thick, 5 sample	320 µl
EVS1300-C10-1.5	1.5 mm thick, 10 sample	160 µl
EVS1300-C24-1.5	1.5 mm thick, 24 sample	60 µl
EVS1300-C30-1.5	1.5 mm thick, 30 sample	50 µl
EVS1300-C48-1.5	1.5 mm thick, 48 sample	30 µl

Replacement parts & Accessories

Code	Description
EVS1300-BASE	Gel casting base, 20 cm
EVS1300-SILMAT	Replacement silicone mat for gel casting base, 20 cm
EVS1300-GELINSERT	Inner running module
EVS1300-COOL	Maxi cooling pack
EVS1300-NGLASS	Notched glass plates, 20x20 cm, 4 mm thick, pk/2
EVS1300-GLASS	Glass plates, 20x20 cm, 4 mm thick, pk/2
EVS1300-GLASS-SP-1.0	Glass plates, 20x20 cm, + 1 mm bonded spacers, pk/2
EVS1300-GLASS-SP-1.5	Glass plates, 20x20 cm, + 1.5 mm bonded spacers, pk/2
EVS1300-DUMMY	Dummy plate, 20x20 cm
EVS1300-SP-1.0	Spacers, 1 mm thick, 20 cm, pk/2
EVS1300-SP-1.5	Spacers, 1.5 mm thick, 20 cm, pk/2
EPT50	Replacement platinum wire, 0.2 mm thick, 50 cm

These systems include all modules and accessories required for slab gel electrophoresis, 2-D electrophoresis and electro-blotting.

The central component is the mini vertical unit, mini-wide vertical unit or maxi vertical unit. These include a rapid and intuitive casting system, enhanced and easy to set up cooling system and have increased capacity (can run up to four gels per run).

In addition, the tube gel module is capable of resolving up to 10 first dimension gels and the electro-blotting module has a four blot (mini) or three blot (mini-wide and maxi) capacity.

Each of these techniques benefits from rapid set up cooling packs which provide enhanced resolution even during high intensity 2-D electrophoresis and electro-blotting.

All replacement parts and accessories of the corresponding vertical units can also be used for these systems.

Recommended power supply: EV3020



● Ordering codes

Code	Description
EVS1100-MULTI	Modular system: EVS1100-SYS + capillary module + electro-blotting module + 2 sets of glass plates with bonded 1 mm thick spacers + 2 combs, 1 mm thick, 12 samples + cooling pack + dummy plate + casting base + 100 capillary tubes (1 mm int. diameter) + blanking plugs + 4 compression cassettes 10x10 cm + 8 fibre pads
EVS1200-MULTI	Modular system: EVS1200-SYS + capillary module + electro-blotting module + 2 sets of glass plates with bonded 1 mm thick spacers + 2 combs, 1 mm thick, 24 samples + cooling pack + dummy plate + casting base + 100 capillary tubes (1 mm int. diameter) + blanking plugs + 3 compression cassettes 20x10 cm + 6 fibre pads
EVS1300-MULTI	Modular system: EVS1300-SYS + capillary module + electro-blotting module + 2 sets of glass plates with bonded 1 mm thick spacers + 2 combs, 1 mm thick, 24 samples + cooling coil + dummy plate + casting base + 100 capillary tubes (1 mm int. diameter) + blanking plugs + 3 compression cassettes 20x20 cm + 6 fibre pads

Replacement parts & Accessories

Code	Description
EVS1100-TUBE-1.0	Mini capillary tubes, 1 mm internal diameter, 8 mm, pk/100
EVS1100-TUBE-1.5	Mini capillary tubes, 1.5 mm internal diameter, 8 mm, pk/100
EVS1100-TUBEPART	Capillary blanking ports pk/10
EVS1300-TUBE-1.0	Maxi capillary tubes, 1 mm internal diameter, 17 mm, pk/100
EVS1100-BLOTINSERT	Mini blot insert + 4 cassettes 10x10 cm + 8 fibre pads
EVS1100-CASSETTE	Mini blot cassette, 10x10 cm
EVS1100-FIBREPAD	Mini fibre pads, 10x10 cm, pk/6
EVS1100-TUBEINSERT	Mini tube gel insert + 100 capillary tubes (1 mm int. diameter)
EVS1200-BLOTINSERT	Mini-wide blot insert + 3 cassettes 20x10 cm + 6 fibre pads
EVS1200-CASSETTE	Mini-wide blot cassette, 20x10 cm
EVS1200-FIBREPAD	Mini-wide fibre pads, 20x10 cm, pk/6
EVS1200-TUBEINSERT	Mini-wide tube gel insert + 100 capillary tubes
EVS1200-BLOTINSERT	Maxi blot insert + 3 cassettes 20x20 cm + 6 fibre pads
EVS1300-CASSETTE	Maxi blot cassette, 20x20 cm
EVS1300-FIBREPAD	Maxi fibre pads, 20x20 cm, pk/6
EVS1300-TUBEINSERT	Maxi tube gel insert + 100 capillary tubes (1 mm int. diameter)

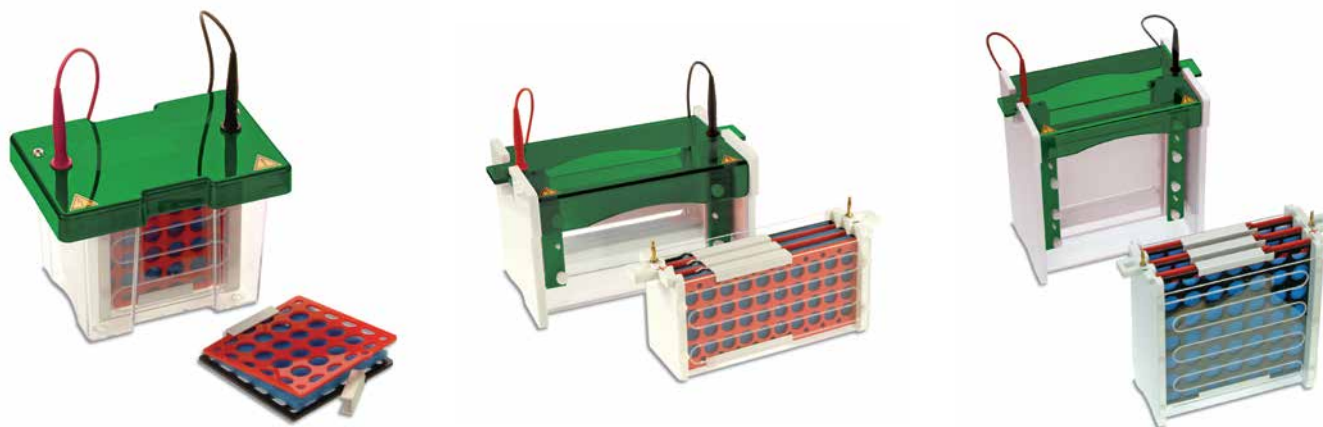

These stand-alone, complete units for electro-blotting, mini, mini-wide and maxi formats, include vertical tank and lid, electro-blotting insert, cassettes and fibre pads.

Units are interchangeable with the vertical slab and tube gel inserts.

Hinged rigid cassettes allow rapid set up and convenience and ensure even contact between the gel and membrane is maintained.

Recommended power supply: EV3020

● Ordering codes

Code	Description
EVS1100-BLOT	Mini blotter: tank & lid + 4 cassettes 10x10 cm + 8 fibre pads + cooling pack
EVS1200-BLOT	Mini-wide Blotter: tank & lid + 3 cassettes 20x10 cm + 6 fibre pads + cooling pack
EVS1300-BLOT	Maxi blotter: tank & lid + 3 cassettes 20x20 cm + 6 fibre pads + cooling pack

Replacement parts & Accessories

Code	Description
EVS1100-BLOTINSERT	Mini blot insert + 4 cassettes 10x10 cm + 8 fibre pads
EVS1100-CASSETTE	Mini blot cassette, 10x10 cm
EVS1100-FIBREPAD	Mini fibre pads, 10x10 cm, pk/6
EVS1200-BLOTINSERT	Mini-wide blot insert + 3 cassettes 20x10 cm + 6 fibre pads
EVS1200-CASSETTE	Mini-wide blot cassette, 20x10 cm
EVS1200-FIBREPAD	Mini-wide fibre pads, 20x10 cm, pk/6
EVS1200-BLOTINSERT	Maxi blot insert + 3 cassettes 20x20 cm + 6 fibre pads
EVS1300-CASSETTE	Maxi blot cassette, 20x20 cm
EVS1300-FIBREPAD	Maxi fibre pads, 20x20 cm, pk/6

These semi-dry blotters offer rapid transfer times for DNA, RNA and protein blotting (typically 15 to 30 minutes). All units can be used for all types of blotting and are compatible with gel thickness from 0.25 up to 10 mm without the need for additional equipment. Each unit is compatible with their respective vertical gel system. Semi-dry blotting has the added benefit of economic transfers due to very low buffer volumes.

These semi-dry blotters utilise a screw down lid, which secures the blot sandwich and allows complete control of pressure ensuring even transfer.

The electrodes, comprising platinum coated anode and stainless steel cathode, will exhibit practically no corrosion and so provide many years of trouble free use. Uniform heat dispersion across the blot sandwich ensures stable transfer times and no heat induced sample loss or transfer distortions. Electrode plates are fully separated to prevent arcing or damage.

Warranty 12 months
Recommended power supply: EV3020



● Ordering codes

Code	Description	Buffer Volume	Max. sample capacity	External dimensions
ESDB1100	Semi-dry blotter, mini, 10x10 cm	5 ml	1 blot, 10x10 cm	16x16x7 cm
ESDB1200	Semi-dry blotter, midi, 20x20 cm	20 ml	1 blot, 20x20 cm or 4 blots, 10x10 cm	26x26x7 cm

Plate dimensions	33x45 cm 20x50 cm
Buffer volume	800 ml to 2000 ml
Sample Capacity	96
Unit Dimensions	30x18x27 cm

Warranty 12 months

Ideal for a variety of large format vertical gel applications, this unit offers advanced features for enhancing gel resolution and ease of use, essential when handling gels of this size.

Resolution is enhanced by using an aluminium heat sink plate, essential for even sample migration. Added convenience is provided by a removable lower buffer tank and upper buffer drainage tap.

Special buffer chambers allow either low buffer volumes to be used for economy or high buffer volumes to be used for extended runs.

A wide range of interchangeable comb and spacer options allows a large number of techniques to be easily accomplished.

Recommended power supply: EV3330. EV3620



Ordering codes

Code	Description
ESEQ1100-SYS	Sequencing unit 33x45 cm glass plates 0.35 mm thick spacers 2 combs: 48 samples, 0.35 mm thick

Combs

Code	Description	Sample volume
ESEQ1100-C48-0.3	0.25 mm thick, 48 sample	7 µl
ESEQ1100-C96-0.3	0.25 mm thick, 96 sample	3 µl
ESEQ1100-C48-0.4	0.35 mm thick, 48 sample	9 µl
ESEQ1100-C96-0.4	0.35 mm thick, 96 sample	5 µl
ESEQ1100-C48-1.0	1 mm thick, 48 sample	35 µl
ESEQ1100-C80-1.0	1 mm thick, 80 sample	20 µl
ESEQ1100-C48-1.5	1.5 mm thick, 48 sample	50 µl
ESEQ1100-C80-1.5	1.5 mm thick, 80 sample	30 µl

Code	Description
ESEQ1200-SYS	Sequencing unit 20x50 cm glass plates 0.35 mm thick spacers 2 combs: 24 samples, 0.35 mm thick

Combs

Code	Description	Sample volume
ESEQ1200-C24-0.3	0.25 mm thick, 24 sample	7 µl
ESEQ1200-C48-0.3	0.25 mm thick, 48 sample	3 µl
ESEQ1200-C24-0.4	0.35 mm thick, 24 sample	9 µl
ESEQ1200-C48-0.4	0.35 mm thick, 48 sample	5 µl
ESEQ1200-C24-1.0	1 mm thick, 24 sample	35 µl
ESEQ1200-C48-1.0	1 mm thick, 48 sample	20 µl
ESEQ1200-C24-1.5	1.5 mm thick, 24 sample	50 µl
ESEQ1200-C48-1.5	1.5 mm thick, 48 sample	30 µl

Replacement parts & Accessories

Code	Description
ESEQ1200-NGLASS	Notched glass plates, 20x50 cm, pk/2
ESEQ1200-GLASS	Plain glass plates, 20x50 cm, pk/2
ESEQ1200-SP-0.3	Spacers, 0.25 mm thick, 50 cm, pk/2
ESEQ1200-SP-0.4	Spacers, 0.35 mm thick, 50 cm, pk/2
ESEQ1200-SP-1.0	Spacers, 1 mm thick, 50 cm, pk/2
ESEQ1200-SP-1.5	Spacers, 1.5 mm thick, 50 cm, pk/2
ESEQ1200-SENSOR	Fan heater sensor kit

Replacement parts & Accessories

Code	Description
ESEQ1100-NGLASS	Notched glass plates, 33x45 cm, pk/2
ESEQ1100-GLASS	Plain glass plates, 33x45 cm, pk/2
ESEQ1100-SP-0.3	Spacers, 0.25 mm thick, 45 cm, pk/2
ESEQ1100-SP-0.4	Spacers, 0.35 mm thick, 45 cm, pk/2
ESEQ1100-SP-1.0	Spacers, 1 mm thick, 45 cm, pk/2
ESEQ1100-SP-1.5	Spacers, 1.5 mm thick, 45 cm, pk/2
ESEQ1100-SENSOR	Fan heater sensor kit



Clinical Electrophoresis



Compact high resolution system for clinical electrophoresis

Accommodates strips and gels up to 24x20cm

Complete range of cellulose acetate gels and kits

Densitometer software and scanner available

Recommended power supply

EV2650

EV2310



● Description

EHCA1100 is the ideal tank for both standard and wet cellulose acetate electrophoresis. It is designed for both routine and research requirements and is built to our high quality standard.

EHCA1100 includes an adjustable support which enables easy and fast adjustment for different lengths of cellulose acetate strip. Strip dimensions up to 24x20 cm.

The ideal tank for standard membrane and gel cellulose acetate techniques, the EHCA1100 electrophoresis system is designed and built to our high quality standard to address both routine clinical and research requirements. Two adjustable supports, which can be positioned anywhere within the tank, readily accommodate different lengths of dry cellulose acetate membrane to a maximum 20cm.

● Ordering codes

Code	Description
EHCA1100-SYS	Horizontal unit for cellulose acetate electrophoresis (without accessories!)

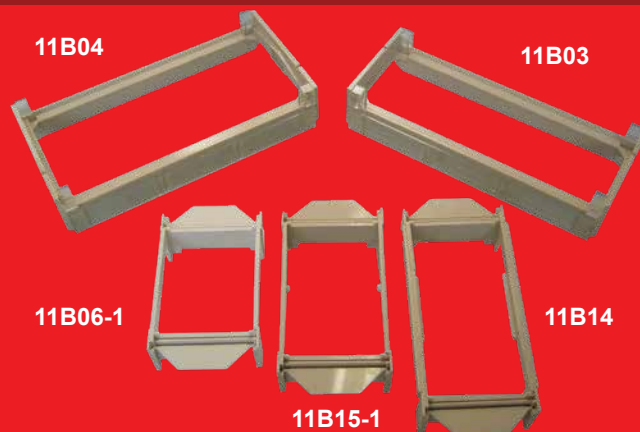

Cellogel is a film of cellulose acetate in gel form. Cellogel is the ideal electrophoretic support for clinical electrophoresis and for the immunological techniques.

- Compact high resolution system for clinical electrophoresis
- Designed for routine and research needs
- Easy loading with bridges
- Fully compatible with Cellogel precast gels and kits
- Complete range of cellulose acetate gels and kits
- Densitometer software and scanner available

Recommended power supply

EV2650
EV2310

Functions with six strips 2.5x14 cm or with three strips 5.7x14 cm on three bridges, model France of 8.5 cm, furthermore it works with the same size strips as above and with sheets 14x14 cm or 18.3x14 cm on an 8.5 cm long bridge with plastic clips.

Injection moulded polycarbonate with high chemical and physical resistance. The lid is in semi-transparent polycarbonate with two magnets which work safety micro-switches and cut off the current when the lid is taken off.

Universal bridges supports Cellogel during sample application by serving as a convenient loading template for the required applicator. Bridges also available for Helena-, Pratiga- and Shandon-type strips and other size formats.

A wide selection of precast gel and strips are available.

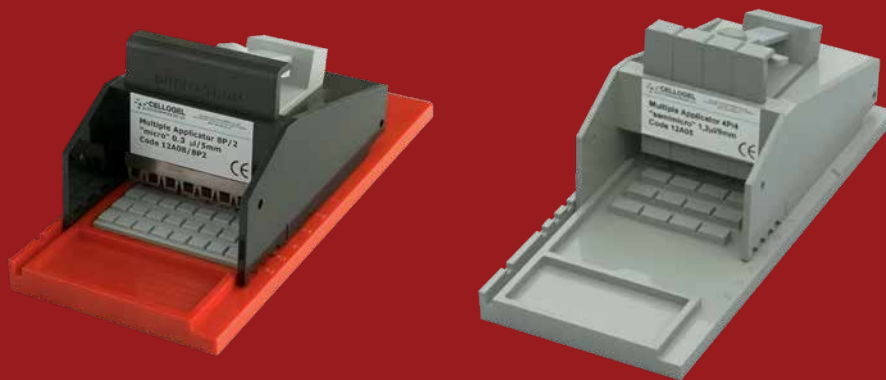

Code	Description
EHCA1200-SYS	Horizontal unit for cellulose acetate including 3 bridges 8.5 for Cellogel strips 2.5 x 14 cm and 5.7 x 14 cm, 1 bridge for Cellogel sheets 18.3 x 14 cm
EHCA1200-BR11B06-1	France bridge, 8.5 cm, for strips of 2.5x14 cm or 5.7x14 cm
EHCA1200-BR11B03	Long bridge for sheets of 18.3x14 cm or 14x14 cm and strips of 2.5x14 cm or 5.7x14 cm. Migration field 8.5 cm
EHCA1200-BR11B15-1	France bridge, 11 cm, for strips of 2.5x17 cm or 5.7x17 cm, Rectangular.
EHCA1200-BR11B04	Long bridge for sheets of 17x17 cm and strips of 5.7x17 cm. Migration field 11 cm.
EHCA1200-BR11B14	France bridge, 14 cm, for Cellogel RS Wedge of 5x18.5 cm and 5.7x18.5 cm Rectangular.
EHCA1200-AP08-8P2	8 Sample Micro Applicator
EHCA1200-AP02-SU	2+2 Samples Semimicro Applicator for 2/5 x 14 cm and IFE kit
EHCA1200-AP08-4P4	4 Samples Semimicro Applicator
EHCA1200-AP05	4 Samples Semimicro Applicator
EHCA1200-AP08-4CS	4 Samples Semimicro Applicator for USP CHONDROITIN SULFATE test
EHCA1200-AP08-6P2	6 Samples Semimicro Applicator
EHCA1200-KC30-R	Serum Proteins kit
EHCA1200-KC31	High Resolution Serum Proteins kit
EHCA1200-KC09	IEF Serum + Concentrated urine kit
EHCA1200-KC64	Glycosylated Hemoglobins HbA1c kit
EHCA1200-KC09-02	Immunofixation
EHCA1200-KC35	Hemoglobins
EHCA1200-KC42	Lipoproteins
EHCA1200-SOFT	Turboscan Universal Densitometer Software
EHCA1200-SCAN	Scanner for EHCA1200-SOFT

● Serum Proteins EHCA1200-KC30-R

The EHCA1200-KC30-R kit is intended for the diagnostic clinical electrophoresis of serum proteins for detecting dysproteinemias and for quantitating Albumin, Alpha-1, Alpha-2, Transferrin, C3 and Gammaglobulins.

Assessment:

4 semimicro or 8 micro tests per each Cellogel 5.7x14 cm strip.
12 semimicro tests or 24 micro tests per each Cellogel chamber.

Kit content (100 semimicro or 200 micro tests):

Cellogel, Tris-Hippurate buffer, Ponceau S staining, Destaining solution, Clearing solution, blotting paper and Mylar film

● High Resolution Serum Proteins EHCA1200-KC31

Several prestigious authors (Drs. Kohn, Laurell, Aguzzi, Keren et. al.) have not accepted the 20 mm micro electrophoresis of proteins since this technique is not sufficient for diagnosis of gammopathies. HR methods such as Microlong electrophoresis on Cellogel show up to 13 fractions, and have been proposed for diagnosis of incipient gammopathies. In accordance with the Italian Commission for Proteins of SIBioC and some of the most authoritative European experts.

Assessment:

6 semimicro or 8 micro tests per each Cellogel 5.7x14 cm strip.
48 high resolution tests with 6 Cellogel strips placed on 2 Cellogel chamber.

Kit content (150 semimicro or 200 micro tests):

Cellogel, TGS buffer, Coomassie staining, Citric Acid, Clearing solution blotting paper and Mylar film.

Not included: Destaining solution (475ml Methanol + 475ml H₂O + 50ml Glacial Acetic Acid).

● IEF Serum + Concentrated urine EHCA1200-KC09

Simultaneous immunofixation of serum and urine of 1 patient is recommended as unique method for an absolutely certain diagnosis able to observe gammopathies of uncertain significance (MGUS) or the malignancy of the gammopathy, with the presence of a K free or Lambda free monoclonal, or secondary malignancy for evident kidney disease with the presence of an IgG, IgA or IgM monoclonal component in the IFE of serum and urine with relative positivity of alligned K (bound) or Lambda (bound).

This method, proposed in 1984 and appreciated from many SIBioC members, doesn't use anti K free and anti Lambda free to reveal Bence-Jones protein and respects the guide lines for IFE of the Bence-Jones proposed for urine alone with trivalent anti-serum (anti IgG, anti IgA, anti IgM), anti K Bound & Free and anti Lambda Bound & Free published in *Biochimica Clinica*, 2001, vol.25, No. 1, pages 23-31

Assessment:

2 test HRE for each patient in semimicro technique on 6 Cellogel 2.5x14 cm strip placed on 3 bridges in one Cellogel chamber.

Kit content (5+5 tests for 5 patients):

Cellogel, TGS buffer, Coomassie staining, Saline solution, Volumetric distributors and Antisera, Clearing solution, blotting paper and Mylar film.

Not included: Destaining solution (475ml Methanol + 475ml H₂O + 50ml Glacial Acetic Acid).

● Glycosylated Hemoglobins HbA1c EHCA1200-KC64

According to a publication of J. Ambler et al., the non-glycosilated part of Hemoglobin in citrate buffer pH 6.4 containing dextrane sulphate acquires a mobility such as to allow a perfect separation of the glycosilated part. This occurs as the sulphate groups of dextrane combine with non-glycosilated hemoglobin.

Assessment:

4 semimicro per each Cellogel 5.7x14 cm strip.
12 semimicro tests per each Cellogel chamber.

Kit content (100 semimicro tests):

Cellogel, Affinity buffer pH 6.4, Hemolysing solution, Ponceau S staining, Destaining solution, Clearing solution, blotting paper, Mylar film and 1 mini box.

● Immunofixation EHCA1200-KC09-2

The EHCA1200-KC09-2 kit is intended for the separation and identification of monoclonal gammopathies. When a monoclonal band is revealed by electrophoresis or when an immunoproliferative disorder is suspected, immunofixation of monoclonal components is basic, either to establish true monoclonality of a band, or to establish the nature of the monoclonal component and fix it. In fact different types have different diagnostic and prognostic value.

Assessment:

6 semimicro tests or 8 micro tests on 6 Cellogel 5.7x14 cm strips placed on 6 bridges in two Cellogel chamber.

Kit content (24 semimicro or 32 micro tests):

Cellogel, Tris- Hippurate buffer, Amidoblack staining, Saline solution, Volumetric distributors and Antisera, Clearing solution, blotting paper and Mylar film.

Not included: Destaining solution (475ml Methanol + 475ml H₂O + 50ml Glacial Acetic Acid).

● Hemoglobins EHCA1200-KC35

Electrophoresis of Hemoglobins is a simple laboratory technique for the rapid and accurate detection of abnormal conditions, called hemoglobinopathies. It can reveal the possible existence of hemoglobinopathies in two ways, qualitatively, by indicating the presence or absence of variant hemoglobins, and quantitatively, by making possible the measurement of hemoglobins by densitometry.

The electrophoretic separation of hemoglobins is based on the electrical characteristic of the globin molecule which can be negatively or positively charged depending on the amino acid sequence or composition of the polypeptide chains. Differences in the electrostatic charge will produce differences in electrophoretic mobilities and, hence, separation of the various hemoglobins.

Assessment:

4 semimicro per each Cellogel 5.7x14 cm strip.
12 semimicro tests per each Cellogel chamber.

Kit content (100 semimicro tests):

Cellogel, Tris-Glycine buffer, Ponceau S staining, Destaining solution, Clearing solution, blotting paper, Mylar film and 1 mini box.

● Lipoproteins EHCA1200-KC42

The EHCA1200-KC42 kit is intended for clinical electrophoresis of serum Lipoproteins and evaluation of HDL (Alpha lipo), VLDL (pre β lipo), LDL (β lipo) and Chylomicrons fractions.

Hyperlipoproteinemias may be categorized into 5 types according to Fredrickson et Al. by simple observation of electrophoretic pattern, serum appearance and determination of values of Cholesterol and Tryglyceride.

Cellogel is widely used in the world for Lipoproteins testing. More than 20 scientific works have been published on international magazines. Main advantage of Cellogel versus dry Cellulose Acetate or Agarose is the right porosity (Chylomicrons can not penetrate or permeate Cellogel membrane), the suitable thickness of 250-300 microns and combination of both hydrophobic and hydrophilic properties of gelatinized cellulose acetate.

Assessment:

4 semimicro per each Cellogel 5.7x14 cm strip.
12 semimicro tests per each Cellogel chamber.

Kit content (100 semimicro tests):

Cellogel, Tris Hippurate buffer, Sudan Black staining, Clearing solution, blotting paper, Mylar film and 1 mini box.

● Ordering codes

Code	Description	Diagnostic Application
EHCA1200-KC30-R	Serum Proteins kit	Dysproteinaemia;Albumin,Alpha-1, Alpha-2,Transferrin, C3 & Gamma Globulin QuantitationI
EHCA1200-KC31	High Resolution Serum Porteins kit	Incipien Gammopathies
EHCA1200-KC09	IEF Serum + Concentrated urine kit	MGUS, MM
EHCA1200-KC64	Glycosylated Hemoglobins HbA1c kit	Haemoglobinopathies
EHCA1200-KC09-02	Immunofixation	MGUS, MM
EHCA1200-KC35	Hemoglobins	Haemoglobinopathies
EHCA1200-KC42	Lipoproteins	Hyperlipidaemias

Cellogel is a film of cellulose acetate in gel form.

Cellogel is the ideal electrophoretic support for clinical electrophoresis and for the immunological techniques.

Cellogel is an electrophoretic medium which separates the proteins, even at high resolution, according to the electric charge and does not have the effects of molecular filtration typical of other gels like polyacrylamide.

Cellogel is packed in strips and sheets of various dimensions.

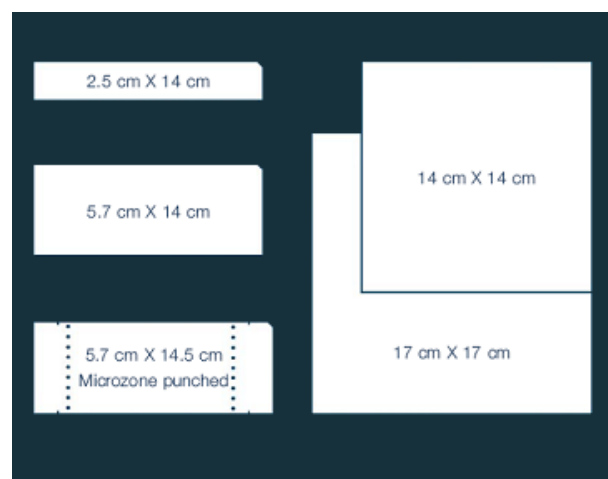

Cellogel is ready for buffering and does not entrap air at the moment of immersion into the electrophoretic buffers.

In comparison with dry acetate, with a thickness from 120 to 160 microns, Cellogel is produced with thicknesses between 190 μ up to 500 μ depending on what it is to be used for. The greater the thickness, greater is the volume of the specimen which can be deposited on it. Furthermore, higher thickness corresponds, with the same voltage applied during electrophoresis and with the same ionic strength of the buffer, to a higher passage of current measured in mA x strip.

With Cellogel there is the possibility to apply specimens with a volume of 0.9 μ l/9 mm (semimicro method) or of 2 μ l/18 mm (micro method) without the sample spreading as would occur on a very thin dry acetate strip which tolerates micro applications of 0.25 μ l/4 mm well but lets the semi-micro and macro deposits spread unacceptably. The application can be repeated two or three times on the same spot on Cellogel, when necessary, as in the case of electrophoresis of isoenzymes and of biological liquids poor in proteins.

Dry acetate is limited to the migrations of 20 mm of miniaturised micro electrophoresis or at most of 30 mm with a quasi-semi-micro carried out with stamp applicators and their relative dispocards. Cellogel, however, is suitable for standard migrations of semi-micro 35 mm serum proteins, with 45 mm semi-micro with prolonged migrations or high resolution electrophoresis with 60-70 mm migrations or more.

HRE (high resolution electrophoresis) is only possible on Cellogel and not on dry acetates. HRE on Cellogel is much simpler and easier than on agarose; the expensive systems for the circulation of cold water or Peltier control which are needed for all the commercial agarose gels with a thickness of 500 microns are not required with Cellogel. HRE on Cellogel has a cost per test equal to a semi-micro test on acetate and does not have the prohibitive costs of agarose which is only produced in kits of 10 or maximum 15 tests per film, which cannot be proposed for the routine of large and medium size laboratories. With French agarose it is only possible to carry out 10 tests/hour, with American agarose 15 tests/hour, while with Cellogel it is possible to perform up to 48 test/hour; furthermore HRE on agarose presents itself with migrations containing a floating β -lipoproteins fraction focused, sometimes, overlapped on a small monoclonal band. In practice, high resolution on agarose is a time consuming system as well as being defective. Cellogel, like agarose, offers resolutions that depend on the length of the migrations. Making a deposit of 0.9 μ l on a line 9 mm long and 1.5 mm wide (semi-micro deposit):

- After 35 mm movement of albumin the serum proteins migration shows 5-6 fractions
- After 50 mm it shows 7-9 fractions
- After 65 mm it shows 9-13 fractions
- After 110 mm it shows between 11 and 23 fractions

Chemically Cellogel is a film of water made of from 7-8% of solid cellulose acetate and 92-93% H₂O of which 60-70% is constitution H₂O bound with hydrogen bridges, and 20-30% water for impregnation of the pores. The evaporation and water transport onto the membrane during prolonged electrophoresis is better regulated, the evaporation of the constitution water bound by the hydrogen bridge is much slowed down and this facilitates long migrations which are impossible on dry acetate. The porosity of Cellogel is predisposed for the main analysis, that is electrophoresis of the serum proteins. Large molecules like pre- β -lipoproteins and all the other serum proteins penetrate and migrate. Only the chylomicrons do not penetrate or migrate and only leave a mark at the start point, the same occurs with immunocomplexes and cryoglobulins when present; these marks which are analytically and diagnostically important, cannot be seen on the French agarose which uses filtering applicators.

The predisposed porosity of Cellogel is decisive in avoiding spreading of samples at the moment of depositing and spreading of the fractions with low mobility during migrations which can be lengthy. All in all the right porosity corrects the insufficiencies of other commercial cellulose acetates membranes. To this must be added the better compatibility between Cellogel and serum proteins, including lipoproteins, that are incompatible with agarose. The latter is, in fact, a film of water (99% H₂O) totally hydrophilic, where the amphiphilic serum proteins with more lipophilic characteristics remain floating on the surface even when the sample is deposited with applicators which cut the gel.

The superiority of Cellogel over agarose was recognised in numerous publications by important authors between 1963 and 1971. Thanks to its amphiphilic properties (hydrophilic and lipophilic) Cellogel has optimal compatibility with specimens as difficult and complex as serum proteins, which are also amphiphilic. Cellogel is, therefore, the ideal support for electrophoresis of serum proteins, hemoglobins, lipoproteins, isoenzymes, for all the immuno-electrophoretic techniques and for the search for antigens, antibodies and tumour markers (especially those immunofixable with polyclonal antibodies).

● Ordering codes Cellogel Strips

Code	Size (cm)	Description
EHCA1200-ST01-100	2.5x12	Cellogel 250 μ
EHCA1200-ST02-100	2.5x12	Cellogel 200 μ
EHCA1200-ST03-100	2.5x12	Cellogel 190 μ for High Resolution
EHCA1200-ST06-100	2.5x14	Cellogel 250 μ
EHCA1200-ST06-25	2.5x14	Cellogel 250 μ
EHCA1200-ST07-100	2.5x14	Cellogel 200 μ
EHCA1200-ST08-100	2.5x14	Cellogel 190 μ for High Resolution
EHCA1200-ST11-100	2.5x17	Cellogel 250 μ
EHCA1200-ST11-25	2.5x17	Cellogel 250 μ
EHCA1200-ST12-100	2.5x17	Cellogel 200 μ
EHCA1200-ST12-25	2.5x17	Cellogel 200 μ
EHCA1200-ST13-100	2.5x17	Cellogel 190 μ for High Resolution
EHCA1200-ST16-100	4x12	Cellogel 250 μ
EHCA1200-ST17-100	4x12	Cellogel 200 μ
EHCA1200-ST18-100	4x12	Cellogel 190 μ for High Resolution
EHCA1200-ST21-100	4x17	Cellogel 250 μ
EHCA1200-ST22-100	4x17	Cellogel 200 μ
EHCA1200-ST23-100	4x17	Cellogel 190 μ for High Resolution
EHCA1200-ST26-25	5x30	Cellogel 250 μ
EHCA1200-ST27-25	5x30	Cellogel 200 μ
EHCA1200-ST28-25	5x30	Cellogel 190 μ for High Resolution
EHCA1200-ST29-25	5.7x13	Cellogel 250 μ Pratiga punched
EHCA1200-ST29U-25	5.7x13	Cellogel 250 μ
EHCA1200-ST30-25	5.7x13	Cellogel 200 μ Pratiga punched
EHCA1200-ST31-25	5.7x14	Cellogel 250 μ
EHCA1200-ST32-25	5.7x14	Cellogel 200 μ
EHCA1200-ST33-25	5.7x14	Cellogel 190 μ for High Resolution
EHCA1200-ST34-25	5.7x14	Cellogel 500 μ
EHCA1200-ST36-100	5.7x14	Cellogel 250 μ
EHCA1200-ST37-100	5.7x14	Cellogel 200 μ
EHCA1200-ST38-100	5.7x14	Cellogel 190 μ for High Resolution
EHCA1200-ST42-25	5.7x14	Cellogel 250 μ Pratiga punched
EHCA1200-ST43-100	5.7x14	Cellogel 200 μ Pratiga punched
EHCA1200-ST43-25	5.7x14	Cellogel 200 μ Pratiga punched
EHCA1200-ST44-25	5.7x14	Cellogel 190 μ Pratiga punched for High Resolution
EHCA1200-ST45-25	5.7x14	Cellogel 500 μ Pratiga punched
EHCA1200-ST52-25	5.7x14.5	Cellogel 250 μ Beckman punched
EHCA1200-ST53-100	5.7x14.5	Cellogel 200 μ Beckman punched
EHCA1200-ST53-25	5.7x14.5	Cellogel 200 μ Beckman punched
EHCA1200-ST54-25	5.7x14.5	Cellogel 190 μ Beckman punched for High Resolution
EHCA1200-ST57-25	2.55x14.5	Cellogel 250 μ Boskamp
EHCA1200-ST58-25	2.55x14.5	Cellogel 200 μ Boskamp
EHCA1200-ST59-25	2.55x14.5	Cellogel 190 μ Boskamp for High Resolution
EHCA1200-ST62-25	7.8x15	Cellogel 250 μ Shandon
EHCA1200-ST63-25	7.8x15	Cellogel 200 μ Shandon
EHCA1200-ST64-25	7.8x15	Cellogel 190 μ Shandon for High Resolution
EHCA1200-ST67-25	5.7x15	Cellogel 250 μ
EHCA1200-ST68-25	5.7x15	Cellogel 200 μ
EHCA1200-ST69-25	5.7x15	Cellogel 190 μ for High Resolution
EHCA1200-ST77-100	5.7x17	Cellogel 250 μ

● Ordering codes Cellogel Sheets

Code	Size (cm)	Description
EHCA1200-SH01-10	10x17	Cellogel 250 μ
EHCA1200-SH02-10	10x17	Cellogel 200 μ
EHCA1200-SH03-10	10x17	Cellogel 190 μ for High Resolution
EHCA1200-SH04-10	10x17	Cellogel 500 μ
EHCA1200-SH06-10	14x14	Cellogel 200 μ for 2D Immuno-electrophoresis
EHCA1200-SH07-10	16.5x14	Cellogel 250 μ
EHCA1200-SH08-10	16.5x14	Cellogel 200 μ
EHCA1200-SH09-10	16.5x14	Cellogel 190 μ for High Resolution
EHCA1200-SH10-10	16.5x14	Cellogel 500 μ
EHCA1200-SH12-10	17x17	Cellogel 250 μ
EHCA1200-SH13-10	17x17	Cellogel 200 μ
EHCA1200-SH14-10	17x17	Cellogel 190 μ for High Resolution
EHCA1200-SH15-10	17x17	Cellogel 500 μ
EHCA1200-SH17-10	20.5x20.5	Cellogel 250 μ
EHCA1200-SH18-10	20.5x20.5	Cellogel 200 μ
EHCA1200-SH19-10	20.5x20.5	Cellogel 190 μ for High Resolution
EHCA1200-SH20-10	20.5x20.5	Cellogel 500 μ
EHCA1200-SH22-10	30x30	Cellogel 250 μ
EHCA1200-SH23-10	30x30	Cellogel 200 μ
EHCA1200-SH24-10	30x30	Cellogel 190 μ for High Resolution
EHCA1200-SH25-10	30x30	Cellogel 500 μ
EHCA1200-SH27-10	18.3x14	Cellogel 190 μ for High Resolution
EHCA1200-SH28-10	18.3x14	Cellogel 200 μ
EHCA1200-SH32-10	18.3x17	Cellogel 190 μ for High Resolution
EHCA1200-SH33-10	18.3x17	Cellogel 250 μ

TurboScan. The universal and flexible high-performance densitometer for your clinical laboratory.

Universal and flexible analysis equipment for the clinical laboratory
 The latest digital image analysis technology
 Analysis programs and analysis masks can be individually defined
 Irrespective of filters, special light sources or staining methods
 High resolution and excellent reproducibility
 High analysis speed
 Extremely simple to handle and comfortable to use
 Reliable, reproducible results
 Analysis results clearly displayed on the monitor
 Clear printout of results
 Software runs under, XP / VISTA / Win 7

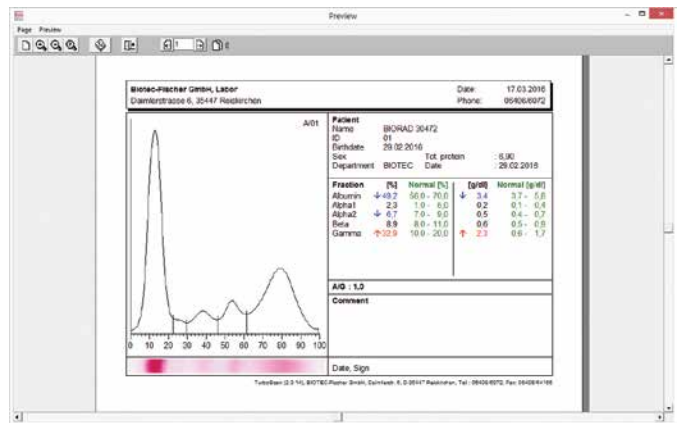

TurboScan. The new generation of densitometers. Once again Biotec-Fischer is leading the way in modern analysis technology with the digital analysis system TurboScan. No other system offers comparable flexibility and comfort. The TurboScan translates users' expectations of a densitometer into reality. Non-essential gadgets have deliberately been left out. Functionality, reliability and operator comfort are the maxims.

Universal use. In terms of flexibility, TurboScan puts all previous systems in the shade. It allows you to create as many individually generated scan masks as you wish. You can also select as many analysis methods as you wish. No other system offers so many options. In clinical work, for example, you can use TurboScan for analysis in the following applications: serum protein electrophoresis, lipo-protein electrophoresis, haemoglobin electrophoresis, Hb-A1 electrophoresis, urine electrophoresis, CSF electrophoresis, Bence-Jones, iso-enzymes, iso-electric focusing, multifractional electrophoresis, blots and lots more. It does not matter whether you carry out your methods on dry or wet cellulose acetate strips, on agarose and on other gels or you work with micro, semi-micro or macro application.

Digital image analysis. technology for reliable results. TurboScan uses the latest digital image analysis technology. The advantages to you are obvious: analysis only takes a fraction of the time and the results obtained are reliable with excellent reproducibility. At the same time TurboScan is based on commercial hardware components. The advantage to you - you can use existing PC hardware and save costs.

Perfect analysis. TurboScan has a very high analysis speed. An A4 page is scanned in only 15 seconds. For the standard template with 64 traces, this means an average scanning speed of 0.23 seconds per separation. The high resolution guarantees reliable results with excellent reproducibility. The analysis data are clearly presented on the colour monitor. The printout shows all the relevant data in a clear form, starting with the image of separation, the graphs, then the laboratory and patient data through to the results in percentages and absolute figures, the normal ranges and your comments.

Easy to operate. In most laboratories, lack of time is a major problem, so careful attention was paid to this aspect when developing the TurboScan. Despite its flexibility and multiple options, it is therefore simple and comfortable to operate. Even under pressure, you will easily find your way round the TurboScan and sources of error are greatly reduced.

The TurboScan software. The TurboScan software lies at the heart of the system. It reflects more than 30 years' experience in this field of electrophoresis analysis. TurboScan automatically recognizes the fractions and assignments present. Each individual separation is automatically coded and every fraction outside the normal range is automatically identified optically. You merely have to look up the result and interpret it. As a matter of course, TurboScan offers you a variety of correction possibilities. You can easily set or delete minimums, correct the baseline, curves of graphs or the albumin factor. After any amendment, TurboScan naturally recalculates all the data for you.

With data processing connection. You can easily connect TurboScan to your DP unit via bi-directional RS-232 interface. This guarantees data exchange between TurboScan and your DP equipment.

● Specifications

TurboScan software on CD-ROM
 PC (Celeron), 256 MB RAM, scanner and inkjet printer
 WINDOWS (98 / NT / 2000 / XP / VISTA)

Patients' Details: first and family name, DOB, sex, ID number, department, total serum protein, comments

Analysis: automatic fraction recognition and assignment, automatic coding of each separation, labelling of fractions outside the normal range

Corrections: set or delete minimums, baseline correction, graph correction, albumin correction

● Ordering codes

Code	Description
EHCA1200-SOFT	Turboscan Universal Densitometer Software
EHCA1200-SCAN	Scanner for EHCA1200-SOFT

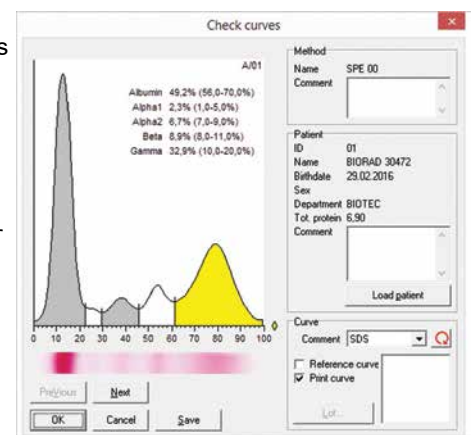

UV Lamps



Key features

Easy to handle

Single or dual wavelength

Long live filter and high UV output

Ondulex® reflector for optimum UV irradiance

Lamp stand or holder to add versatility



● Description

The Vilber Lourmat lamps are provided in 254, 312, 365 nm or combined. The unique filter minimizes white light interference allowing you to easily detect weak fluorescence.

The filter has unlimited life expectancy for 312 and 365nm (3000 hours for 254 nm).

● Ordering codes

Code	Tubes (Watt)	nm	$\mu\text{W}/\text{cm}^2$
VL215-L	2x15 W	365	2300
VL215-C	2x15 W	254	1780
VL215-M	2x15 W	312	3000
VL215-LC	2x15 W	365/254	1350/1100
VL215-LM	2x15 W	365/312	1350/1800
VL215-MC	2x15 W	312/254	1800/930
VL115-L	1x15 W	365	1100
VL115-C	1x15 W	254	1000
VL115-M	1x15 W	312	1000
VL6-L	1x6 W	365	800
VL6-C	1x6 W	254	820
VL6-LC	2x6 W	365/254	720/520

The CN-15 darkroom provides a large effective capacity and UV power intensity unequalled in this field. The darkrooms offer any combination of UV sources, simultaneously or not. Its key features are:

- Extra large capacity
- Black rubber curtain for easy access into the darkroom
- White-light bulb for normal observation
- UV absorber shield to protect the user from UV light
- Removable bottom panel for use with a Vilber Lourmat ETX fluorescent table



The CN-6 darkroom holds one or two hand-held UV lamps... (VL-6 model) in any of the three following wavelengths: 254, 365 or 312 nm. The darkroom is supplied without lamps and allows different lighting possibilities according to the user's choice. Its key features are:

- Large capacity
- Black rubber curtain for easy access into the darkroom
- UV absorber shield to protect the user from the UV light
- Removable lamps that can be used for hand-held applications



● Ordering codes

Models	Tubes (Watt)	Wavelength(nm)	Intensity at bottom ($\mu\text{W}/\text{cm}^2$)	Size W x D x H (mm)
VLCN15-LL	4 x 15-W	365	2 000	505 x 415 x 280
VLCN15-CC	4 x 15-W	254	1 750	
VLCN15-MM	4 x 15-W	312	2 500	
VLCN15-LC	4 x 15-W	365/254	1 050/900	
VLCN15-LM	4 x 15-W	365/312	1 050/1300	
VLCN15-MC	4 x 15-W	312/254	1 300/900	
VLCN6	Lamps not included			300 x 280 x 240

- Ergonomic fusion-Patented 4° ergonomic viewing angle ("Golden Angle")
- Optimized for use with the nucleic acid and protein fluorescent dyes
- Blue light source good for 30,000 hours
- No risk of UV damage for high quality work experience
- Smart power-saving function - Automatic power shut-off option at 5 minutes.
- Gel-cutting knife - Cut out the target from the gel for further experiment



Blook is a remarkable blue light LED transilluminator for the detection of nucleic acids or protein under non-UV conditions. The wavelength of the special blue LED lights is 470 nm, hence no damage to your nucleic acids or protein. Also, since UV is not used, there is no need for any special personal eye or skin protection.

The blue LED lights are arranged under the viewing area (200 × 120 mm). An amber filter, on hinges, is lowered into position once your gel is mounted. The stained gel is now ready for viewing. This instrument has a specially designed ergonomic 4° angle, so users can easily sit on a chair to see the experiment results.

Blook is designed to view the gel after running electrophoresis on the gel stained with the Novel Juice, Novel Green, Novel Green Plus, Nimble Juice or Nimble Juice R TYPE. Further, it is perfectly designed for OnePCR™, OnePCR™ HiFi, OnePCR™ HotStar, OnePCR™ Plus, OneMARK B, and OneMARK 100, which contains the fluorescent stain compatible with the blue light wavelength.

However, Blook is not suitable for ethidium bromide.

Code	Description
BLOOK	LED gel documentation table



● Face shield and goggle

UV radiation is dangerous for unprotected eyes and skin. Users must protect themselves against UV radiation by wearing glasses or face shields. The MP-80 is recommended for the protection of the eye and the face.

The MP-800 is a face shield with two lateral protections to cover the operator ears in addition to his eyes and face.

Comfortable and efficient, the LP-70 glasses provide total protection for the eyes.

Code	Description
VLMP800	MP-800 UV face shield with lateral protection
VLMP80	MP-80 UV face shield
VLLP70	UV glasses



MP-800



MP-80



LP-70

● Replacement UV tubes and starters

Code	Description	Length
VLT15-M	UV tube, 15 W, 312 nm	451 mm
VLT15-C	UV tube, 15 W, 254 nm	451 mm
VLT15-L	UV tube, 15 W, 365 nm	451 mm
VLT8-M	UV tube, 8 W, 312 nm	302 mm
VLT8-C	UV tube, 8 W, 254 nm	302 mm
VLT8-L	UV tube, 8 W, 365 nm	302 mm
VLT6-C	UV tube, 6 W, 254 nm	226 mm
VLT6-L	UV tube, 6 W, 365 nm	226 mm
VLT4-C	UV tube, 4 W, 254 nm	136 mm
VLT4-L	UV tube, 4 W, 365 nm	136 mm

ABSOLUTE READINGS

The instrument shows the actual value without compensating to a reference temperature.

AC-ADAPTOR

An internationally approved mains-plug with built-in low voltage transformer for a safe supply of energy to instruments.

ACCURACY

Maximum electronic error of the measured unit. The accuracy of an electrochemical determination such as pH, conductivity, dissolved oxygen & ion-selective measurements is mainly limited by the electrodes and calibration solutions.

ALARM

An alert sounds or a relay is closed when readings stray outside pre-set limits.

ALTERNATING DISPLAY

The meter can automatically scan all selected inputs for display or transmission to a computer or printer.

AUTOMATIC CROSS-OVER

When the resistance of an electrophoresis apparatus changes during a run, the power supply is able to switch automatically between constant voltage, constant current and constant power.

BATTERY CAPACITY

Percentage of remaining battery capacity.

BAUD RATE

Communication speed, in bits/second (b/s), of the digital interface (RS232).

BUFFER

A solution of buffered species where the pH tends to remain constant if diluted or concentrated.

Pre-programmed pH buffers: 1.68/ 2.00/ 4.00/ 4.01/ 6.87/ 7.00/ 9.18/ 9.21/ 10.01/ 12.00/ 12.45.

User specified pH buffers: special tables can be stored for future calibrations.

CALIBRATION REMINDER

A timed calibration procedure facilitates considerably GLP management by prompting the user when his instrument needs to be recalibrated.

CAPACITIVE COMPENSATION

The capacity of the electrode and its cable falsifies the measurement at very low conductivities. A capacity compensation allows to compensate for these errors.

CELL

The 2-pole design is the most commonly used conductivity cell. The electrodes are made of platinised platinum. The cell must be replaced or re-platinised if the plates become fouled.

The 4-pole design reduces considerably the problems of polarisation and fouling. By utilising four electrodes, no current flows through the measuring circuit. The AC-current is only applied to the outer pair of rings allowing the inner pair of electrodes to measure the voltage without any polarisation effects.

CELL CONSTANT

The cell constant (cm⁻¹) of a conductivity electrode is determined by the length (cm) of the column of liquid between the plates divided by the area (cm²) of the plates.

CONCENTRATION

Concentration measurement with an ion selective electrode requires a minimum of chemical know-how to make successful ion selective determinations.

CONDUCTIVITY

The conductivity is a measure of the solution's ability to conduct electric current. The basic unit is Siemens/cm (S/cm). It is measured by an electrode consisting of two platinum plates to which an alternating potential is applied. The corresponding current is proportional to the conductivity of the ionic solution in which the electrode is dipped.

DATA-ACQUISITION

Connect the instrument to a computer via an USB, RS232, RS485 interface for bi-directional communication capabilities. Most instruments require no special software and feature an advanced easy to use data acquisition fully compatible with spread-sheet.

DATA-LOGGING

Stores automatically or manually the measured values (+ °C & time/date) in a built-in non-volatile memory.

GLP

Good Laboratory Practices procedures help to increase accuracy through calibration reports.

GROUND LEAKAGE

Leaking or dirty electrophoresis apparatus are dangerous, since the applied high voltage may result in an electric current flowing through the operator to the ground.

IDENTIFICATION NUMBER

Several instruments connected to the same computer can easily be identified when specific numbers are allocated to them.

INPUT

Several types of connectors are used according to the application. Check the specifications of meter-input and electrode-plug on their compatibility.

ISO-pH

Zero-point of a pH electrode. A new pH electrode has an ISO-pH between 6.5

and 7.5 pH.

MINIMUM/MAXIMUM MEMORY

Recalls the lowest/highest values ever measured since the last calibration.

mV

Electrode potential is read in mV.

ON/OFF CONTROL

Simple control system in which the relays are continuously closed when a pre-set level is exceeded.

ORP

Oxido-Reduction-Potential (the reducing or oxidising capability of a solution).

PASSWORD PROTECTION

For tamper-proof storage of parameters and data, a secret personal code protects the instrument against any undesired access.

pH

The pH is a measurement for the acidity or alkalinity of a solution. In pure water the hydrogen ion (H⁺) and hydroxyl ion (OH⁻) concentrations are equal at 10⁻⁷ M (25°C). To provide a convenient and effective means of defining acidity and alkalinity, the negative logarithm of hydrogen ion activity is used. The pH is calculated from the potential between a glass and a reference electrode (Nernst equation).

PROPORTIONAL CONTROL

The control relay will pulse at a rate proportional to the regulation difference. When the difference is superior to a pre-set maximum value, the relay is continuously activated. However, when reaching a pre-set level the wait-time between the pulses will increase gradually in order to perform very accurate regulations.

Pt100

Platinum resistance thermometer (100 Ω at 0°C). It requires a low resistance cable for highest accuracy.

Pt1000

Platinum resistance thermometer (1000 Ω at 0°C). Less errors when using longer cables.

QUALITY MANAGEMENT

Measuring equipment should be calibrated on a regular basis (GLP). The accuracy of measurements is only limited by the electrodes and calibration solutions. At any moment, a complete documentation about the electrodes and calibration solutions can be printed or sent to a computer. This includes meter settings, data about the last calibration and a comparison with the previous calibration. The use of certified calibration solutions is strongly recommended. For very accurate quality measurements fresh standard solutions should be used for each calibration.

QUANTIFICATION OF VINCENT

The quantification of Vincent is a measurement for the energy stored in an organism. It expresses the maximum dissipation of energy by a chemical or biochemical reaction. The basic unit is Watt (W) but it is more convenient to use μW (micro-watt). It is calculated from the ORP, referenced against a hydrogen electrode, and the resistance.

RANGE LOCK

Allows to lock the initial conductivity measuring range when titrating in order to avoid cross-over errors due to varying measuring frequencies and linearity errors of the conductivity cell.

REAL TIME CLOCK

Shows time and date on the display.

REDOX POTENTIAL

The potential developed by a metallic electrode when placed in a solution containing a species in two different oxidation states. It is usually measured by a combination platinum electrode.

REFERENCE TEMPERATURE

Conductivity measurements are temperature dependent. Therefore, the readings should be referenced to a standard temperature.

RESISTIVITY

Electrical resistivity is the reciprocal of Conductivity. The basic unit is Ohm.cm ($\Omega\cdot\text{cm}$). While the ion concentration of a solution decreases, the resistivity rises up to a maximum of $18.3\text{ M}\Omega\cdot\text{cm}$ (absolute pure water at 25°C).

RESOLUTION

Smallest possible reading of the measured unit. More sophisticated meters allow to select the desired resolution. Unlike other meters, the CONSORT models round off the last digit rather than simply truncating digits outside the display range.

rH2

The rH2 is a measurement for the level of electronic exchanges between water and dissolved ions. It enables to study incomplete, indeterminate and very diluted aqueous redox solutions. It is defined as the negative logarithm of molecular hydrogen ion activity, calculated from the pH and the ORP referenced against a hydrogen electrode.

RS232

Digital interface, transmits the displayed values and calibration data to a printer or computer.

RS485

Allows to connect several process controllers for bi-directional communication with a computer. It allows multiple devices (up to 32) to communicate at half-duplex on a single

pair of wires, plus a ground wire, at distances up to 1200 meters.

SALINITY

Salinity gives an indication of the salt content of sea water. It is calculated from the conductivity referred to 15°C . The salinity is the ratio between the total salt content (g) and the total weight of the sea water (kg). Hence salinity can be expressed in ppt (parts per thousand).

SLOPE

Percentage which relates the actual behaviour of a pH electrode to the Nernst's law. A new electrode has a slope between 95 and 100 %.

S/S RELAY

A solid-state relay contains no mechanical contacts. Long life, compact design and spark-free switching are its main advantages. It should not be used for controlling very low power loads, as the small leakage current can cause unwanted switching-on.

STABILITY INDICATION

A decimal point flashes until the electrode output remains constant, then readings can be recorded.

TDS

Total Dissolved Salts of a solution gives an indication of the total ion concentration. Due to ionic interactions within a solution, the salt concentration cannot easily be related to conductivity. As the dissolved solids are generally unknown, a TDS measurement is always referred to a solution of pure Sodium Chloride.

TEMPERATURE COEFFICIENT

Each solution has its own temperature coefficient (%/K). As this coefficient also varies with temperature, a standard conductometer cannot achieve a precise temperature compensation over a wide span of temperatures. However, a research grade meter is able to plot special temperature curves for each individual type of solutions in its non-volatile memory. Specific temperature coefficients can also be entered for special applications. For standard applications, the non-linear function for natural waters (EN27888) is used.

TEMPERATURE COMPENSATION

Corrects readings for variations in electrode response due to temperature effects.

THERMOCOUPLE

Thermocouples basically consist of two dissimilar wires (each made of a different alloy). One end is twisted or soldered to form a measuring junction. The other end is connected to a thermometer and forms the reference junction. The signal is a small voltage (μV) proportional to the temperature

gradient between the measuring and reference junctions. Thermocouple probes are ideal to cover greater lengths. They also have a great temperature range and can easily pass through e.g. oven doors. Response time is faster than with Pt100 probes. Accuracy, stability and repeatability are less than with Pt100 probes.

USB

Universal Serial Bus is a standard designed to eliminate the guesswork in connecting peripherals to a computer.

VOLT-HOUR INTEGRATOR

The distance at which molecules migrate in an electrophoresis apparatus depends on the applied voltage and run-time ($\int V\cdot dt$). In order to achieve reproducible experiments, it is recommended to use a volt-hour integrator rather than a simple timer.

ZERO POINT (E_0)

Standard pH meters assume a pH electrode to supply a zero potential at 7 pH. Electrodes for special applications (e.g. stomach pH measurements) may have a different zero point. An adjustable zero point correction feature will allow users to measure with these electrodes.

Art. 1

Unless otherwise agreed in writing, the legal relationship between the parties is governed by the present general terms, of which the customer declares to have taken cognisance, and which prevail over the customer's possible terms of purchase.

Art. 2

All quotations are without engagement. Prices do not include taxes. Any price stated is based at all times on the salaries, social charges and prices of materials obtaining on the date of the quotation. Official price modifications as arranged by legal dispositions automatically entail equivalent modifications of the prices stated in the contract. This proportional increase can also apply to part of the order or work.

Art. 3

Transport or dispatch of our goods by any means of transport is at the consignee's risk, even with carriage paid.

Art. 4

If our firm acts as an intermediary, the guarantee on the goods supplied by us is restricted to the guarantee given to us by the supplier or manufacturer. If the goods are subject to formal guarantee, defective, material will be repaired or replaced, but no claims for any other damage will be accepted.

Art. 5

All invoices are payable cash on the address of the invoice unless otherwise stipulated in the documents committing the parties or unless an expiry date is stated on the Invoice.

Art. 6

Contrary to art. 1583 of the Civil Code, any goods that are not paid in full remain our full property; in such case possible advance payments will serve as a compensation for costs and loss of profit.

Art. 7

Bills in arrears entitle us to suspend any further deliveries or services without prior notice, such to prevent debts from further increasing.

Art. 8

The supply of goods or services on a later date than the date stipulated for supply or service, if such is not caused by bad faith or a serious shortcoming of the supplier, shall never form a motive for suspending the order or the agreement, nor entitle the customer to claim any damages.

Art. 9

If default is made in cash payment or if payment is not carried out on the expiry date stated, the amount of the invoice shall bear a conventional interest of 1.5% per month as from the day on which the invoice is remitted or as from the expiry date stated, such by right and without any formal notice. Each month started shall be charged as a full month.

Art. 10

Moreover, by way of a fixed and irrevocable condition, the amount of the invoice shall be increased by 15% with a minimum of 200 EUR, by right and without formal notice, as a compensation for recovery costs of the claim (both staff and administration costs, management and follow-up of the file, influences on financial management, etc.), in application of art. 1147 C.C. and 1152 C.C. This compensation is due apart from the moratory interests, the recoverable procedure costs and the possible compensation for material damages and loss of profit. The parties thus agree that this compensation is fixed and that, contrary to art. 1231 C.C. It cannot be modified, even when the shortcoming is only partial.

Art. 11

Cheques and bills of exchange are only accepted as payment after their repayment. Possible costs are at the expense of the purchaser or commissioner.

Art. 12

The drawing and/or accepting bills of exchange or other transferable documents does not imply a novation or deviation from the general terms. The acceptance costs of bills of exchange are at the expense of the purchaser or commissioner.

Art. 13

If one invoice remains unpaid on its expiry date, the balance due of any other invoices, even when not expired, are immediately recoverable by right.

Art. 14

In the event of a dispute, only the courts of Turnhout, Belgium, shall have competence.

Art. 15

Any complaints regarding the supply of the goods and services shall be made on termination and be confirmed by a motivated registered letter within 8 days of the date of supply. These complaints do not suspend the obligation of payment.

Art. 16

Remarks and restrictions concerning the invoice and/or the general terms therein stated shall be transmitted to us by motivated registered letter within 8 days of date of invoice; for the settlement of disputes this period amounts to 30 days. If an order form is signed by a purchaser or commissioner, the regulations of the general terms stated on the order form shall apply.