

TECHNICAL
CATALOGUE
RESIDENTIAL
AIR CONDITIONING
2020-2021

- WALL MOUNTED AC
- UNI SPLIT SERIES
- MULTI VARIABLE SERIES
- HIGH POWER MULTI SYSTEM
- HIGH STATIC PRESSURE DUCT UNIT
- PORTABLE DEVICES



SINCLAIR
AIR CONDITIONING

CONTENT

RAY SERIES	3
VISION SERIES	6
FOCUS+ SERIES	9
SPECTRUM SERIES	12
SPECTRUM+ SERIES	15
CONSOLE SERIES	18
UNI SPLIT SERIES	21
MULTI VARIABLE SERIES	36
HIGH POWER MULTI SYSTEM SERIES	51
DISTRIBUTION BOXES	51
HIGH STATIC PRESSURE DUCT UNIT	58
WINDOW SERIES	60
TOWER SERIES	61
CAMPER TRAILER	62
BOAT SERIES	63
LOCAL AIR CONDITIONERS	65
DEHUMIDIFIERS	66
AIR PURIFIER	67
COMMUNICATION MODULE SCMI-01.4	68
HEALTH FILTERS	71
WIRED CONTROLLERS	72
CENTRAL CONTROLLERS	74
OTHER ACCESSORIES	76
SYSTEM ERROR DIAGNOSTICS	77
ERROR CODES	78

WALL MOUNTED SPLIT AIR CONDITIONERS

RAY SERIES

MODEL			ASH-09BIR	ASH-12BIR			
Capacity cooling/heating 1)	Nominal (min-max)	kW	2,5 (0,5-3,4) / 2,8 (0,5-3,5)	3,2 (0,6-3,6) / 3,4 (0,6-4,4)			
Power supply		Hz / V	1~ / 50 / 220-240	1~ / 50 / 220-240			
Power supply		-	outdoor	outdoor			
Power input cooling/heating 1)		W	781 / 777	997 / 941			
Maximal power input 2)		W	1500	1500			
Power current cooling/heating		A	4,0 / 3,7	4,5 / 4,4			
Maximal power current 2)		A	6,3	7,2			
Energy class cooling 3)		-	A++	A++			
Pdesign cooling		kW	2,5	3,2			
SEER		-	6,1	6,1			
Annual power consumption cooling		kWh / annum	143	184			
Energy class heating 3)	Aver./Warm./Cool.	-	A+ / A+++ / B	A+ / A+++ / B			
Pdesign heating	Average climate	kW	2,6	3,2			
SCOP	Average climate	-	4,0	4,0			
Annual power consumption heating	Average climate	kWh / annum	910	1120			
Air flow of ID	SH/H/M/L	m³ / h	550/500/430/300	550/480/410/290			
Airflow of OD	H	m³ / h	1600	2200			
Sound pressure level of ID at 1m 4)	SH/H/M/L	dB(A)	40/37/35/28	42/37/35/28			
Sound pressure level of OD at 1m 4)	H	dB(A)	52	52			
Sound power of ID 4)	SH/H/M/L	dB(A)	55/49/47/40	55/49/46/40			
Sound power of OD 4)	H	dB(A)	60	62			
Dehumidifying volume		l / h	0,8	1,4			
Refrigerant type/charge		Type / kg / t eq. CO ₂	R32 / 0,60 / 0,41	R32 / 0,65 / 0,44			
Additional refrigerant		g / m	20	20			
Pipe diameter - liquid side 5)		inch / mm	¼ / 6,0	¼ / 6,0			
Pipe diameter - gas side 5)		inch / mm	¾ / 9,5	¾ / 9,5			
Max pipe length without additional refrigerant 6)		m	5	5			
Allowed pipe length 7)	min./max.	m	3 / 15	3 / 20			
Max. elevation/ Drop height		m	10	10			
Dimension of ID	w x h x d	mm	773x250x185	773x250x185			
Dimensions of outdoor unit	w x h x d	mm	782x540x320	842x596x320			
Package dimension of ID	w x h x d	mm	822x322x255	822x322x255			
Package dimensions of outdoor unit	w x h x d	mm	823x595x358	881x645x363			
Weight of ID	netto / brutto	kg	8,5 / 9,5	8,5 / 9,5			
Weight of OD	netto / brutto	kg	29,0 / 31,5	31,0 / 34,0			
Set temperature range		°C	16 ~ 30	16 ~ 30			
Operating temperature range cooling 8)		°C	-15 ~ 43	-15 ~ 43			
Operating temperature range heating 8)		°C	-15 ~ 24	-15 ~ 24			
ADDITIONAL TECHNICAL INFORMATION							
Screw holes distance of OD	w x d	mm	510x286	540x286			
Communication cable		mm²	4 x 0,75 (5m included)				
Recommended power cable		mm²	3x1,5	3x1,5			
Recommended air switch		A	10	13			
EQUIPMENT							
Plasma generator	indoor		-	-			
Wifi module			-	-			
Drain pump			-	-			
Max. lift (from bottom of ID unit)		mm		-	-		
Dry contact (ON/OFF)				-	-		
Alarm contact				-	-		
Fresh air inlet	outdoor		-	-			
Throttling method			Capillary	Capillary			
Bottom chassis heater			-	-			
Crankcase heater			Preheating	Preheating			
Bottom plugs for OD				-	-		
Drain pipe connector				✓	✓		
STANDARD ACCESSORIES							
Standard health filter			-	-			
Remote controller (IR)			YAW1F5 (wifi)	YAW1F5 (wifi)			
Wired controller			-	-			
OPTIONAL ACCESSORIES							
Optional health filters			SAF-OPWA4, SAF-OPWB4, SAF-OPWC4, SAF-OPWK4, SAF-OPWM4, SAF-OPWP4, SAF-OPWS4				
Wired controller			-	-			
Central controller			-	-			
Other			G2S, G2S-T, SAI-01	G2S, G2S-T, SAI-01			

The specification of products is subject to change based on further development of the units by the producer and can be changed without prior notice. Refer to rating label.

R32 (single component refrigerant HFC), GWP of refrigerant used: 675.

Contains fluorinated greenhouse gases covered by the Kyoto Protocol.

Explanatory notes on the very last page of the catalogue.

The device is being sold as a set (indoor + outdoor unit).

APPEARANCE AND DIMENSIONS OF INDOOR UNIT

RAY SERIES

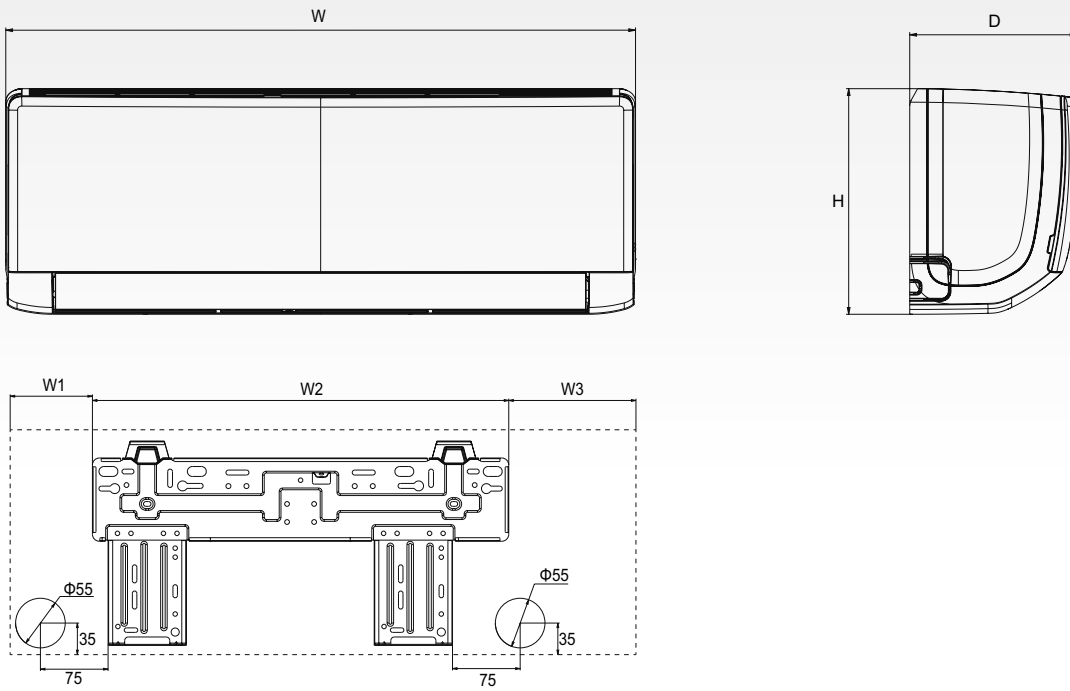

Model:	W	H	D	W1	W2	W3
09/12K	773	250	185	131	462	180

units: mm

ELECTRICAL WIRING DIAGRAM

RAY SERIES

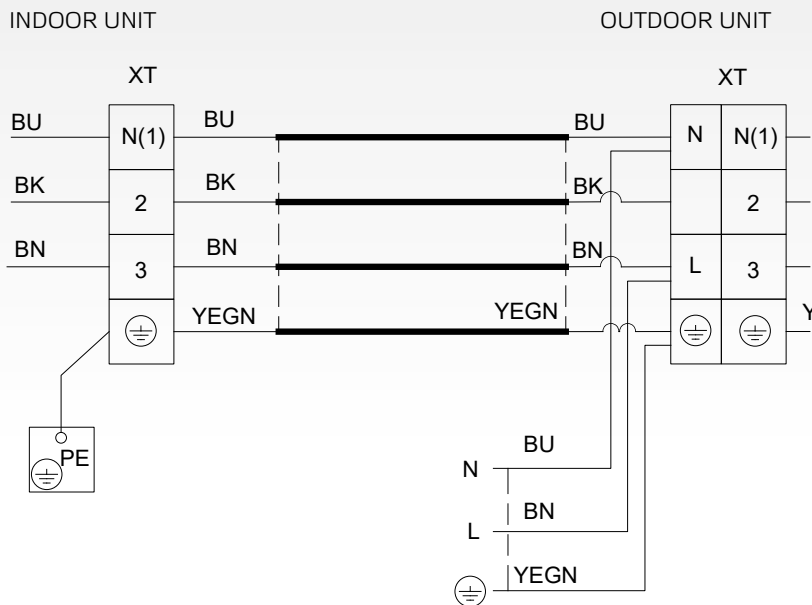

APPEARANCE AND DIMENSIONS OF OUTDOOR UNIT

RAY SERIES

ASH-09BIR

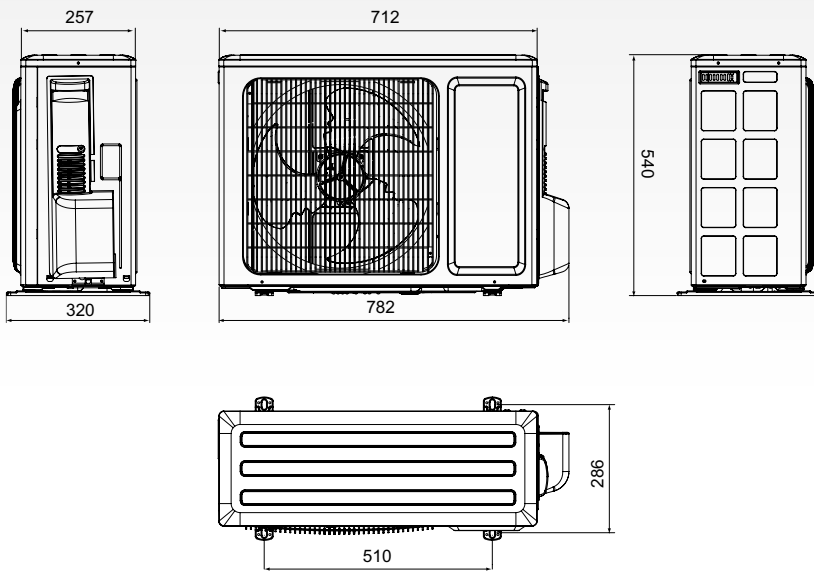

units: mm

ASH-12BIR

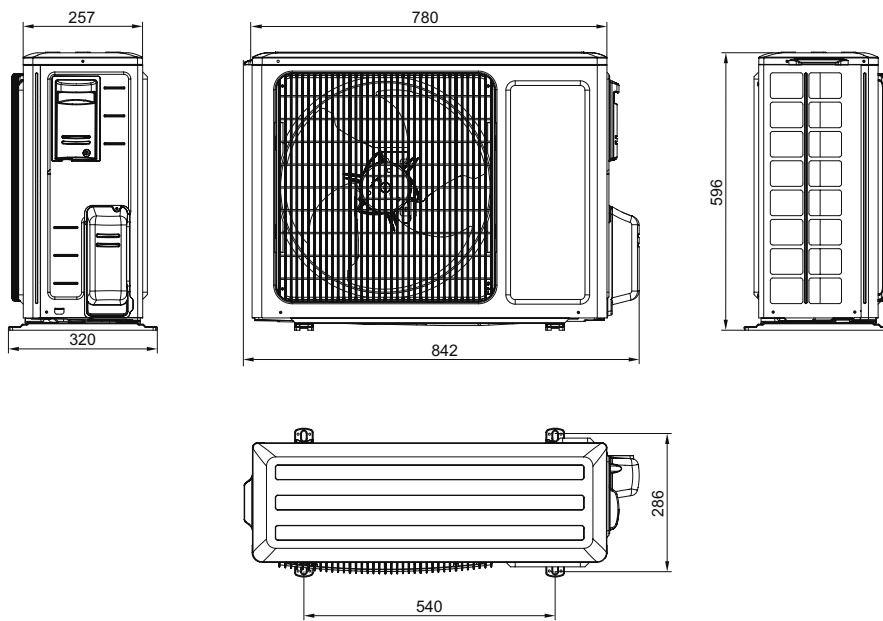

units: mm

WALL MOUNTED SPLIT AIR CONDITIONERS

VISION SERIES

MODEL			ASH-09BIV	ASH-12BIV	ASH-18BIV	ASH-24BIV	
Capacity cooling/heating 1)	Nominal (min-max)	kW	2,5 (0,5-3,4) / 2,8 (0,5-3,5)	3,2 (0,6-3,6) / 3,5 (0,6-3,8)	4,6 (0,7-5,2) / 5,2 (0,7-5,4)	6,2 (1,8-6,4) / 6,5 (1,6-6,6)	
Power supply		Hz / V	1~ / 50 / 220-240	1~ / 50 / 220-240	1~ / 50 / 220-240	1~ / 50 / 220-240	
Power supply		-	outdoor	outdoor	outdoor	outdoor	
Power input cooling/heating 1)		W	805 / 755	997 / 970	1430 / 1400	1760 / 1860	
Maximal power input 2)		W	1500	1500	1700	2600	
Power current cooling/heating		A	3,9 / 3,4	4,4 / 4,3	6,3 / 6,2	7,7 / 8,1	
Maximal power current 2)		A	6,3	6,7	8,0	10,9	
Energy class cooling 3)		-	A++	A++	A++	A++	
Pdesign cooling		kW	2,5	3,2	4,6	6,1	
SEER		-	6,1	6,1	6,1	6,1	
Annual power consumption		kWh / annum	143	184	264	350	
Energy class heating 3)	Aver./Warm./Cool.	-	A+ / A+++ / B	A+ / A+++ / -	A+ / A+++ / -	A+ / A+++ / -	
Pdesign heating	Average climate	kW	2,6	3,2	3,6	4,7	
SCOP	Average climate	-	4,0	4,0	4,0	4,0	
Annual power consumption	Average climate	kWh / annum	910	1120	1260	1645	
Air flow of ID	SH/H/M/L	m³ / h	560/490/430/330	560/480/410/290	850/720/610/520	850/720/610/520	
Airflow of OD	H	m³ / h	1600	2200	2200	3200	
Sound pressure level of ID at 1m 4)	SH/H/M/L	dB(A)	39/36/32/28	42/37/34/28	49/45/41/36	48/44/40/34	
Sound pressure level of OD at 1m 4)	H	dB(A)	52	52	54	57	
Sound power of ID 4)	SH/H/M/L	dB(A)	55/52/44/38	55/47/44/38	58/54/49/44	59/54/50/44	
Sound power of OD 4)	H	dB(A)	61	62	63	67	
Dehumidifying volume		l / h	0,8	1,4	1,8	1,8	
Refrigerant type/charge	Type / kg / t eq. CO ₂		R32 / 0,60 / 0,41	R32 / 0,59 / 0,41	R32 / 0,77 / 0,54	R32 / 1,30 / 0,88	
Additional refrigerant	g / m		20	20	20	40	
Pipe diameter - liquid side 5)	inch / mm		¼ / 6,0	¼ / 6,0	¼ / 6,0	¼ / 6,0	
Pipe diameter - gas side 5)	inch / mm		¾ / 9,5	¾ / 9,5	¾ / 9,5	¾ / 16,0	
Max pipe length without additional refrigerant 6)	m		5	5	5	5	
Allowed pipe length 7)	min./max.	m	3 / 15	3 / 20	3 / 20	3 / 25	
Max. elevation/ Drop height		m	10	10	10	10	
Dimension of ID	w x h x d	mm	790x275x200	790x275x200	970x300x224	970x300x224	
Dimensions of outdoor unit	w x h x d	mm	782x540x320	848x596x320	848x596x320	963x700x396	
Package dimension of ID	w x h x d	mm	866x271x367	866x271x367	1041x383x320	1041x383x320	
Package dimensions of outdoor unit	w x h x d	mm	823x595x358	881x645x363	881x645x363	1029x750x458	
Weight of ID	netto / brutto	kg	9,0 / 11,0	9,0 / 11,0	13,5 / 16,5	13,5 / 16,5	
Weight of OD	netto / brutto	kg	29,5 / 32,0	31,0 / 34,0	34 / 37	46 / 50,5	
Set temperature range		°C	16 ~ 30	16 ~ 30	16 ~ 30	16 ~ 30	
Operating temperature range cooling 8)		°C	-15 ~ 43	-15 ~ 43	-15 ~ 43	-15 ~ 43	
Operating temperature range heating 8)		°C	-15 ~ 24	-15 ~ 24	-15 ~ 24	-15 ~ 24	
ADDITIONAL TECHNICAL INFORMATION							
Screw holes distance of OD	w x d	mm	510x286	540x286	540x286	560x364	
Communication cable		mm²	4 x 0,75 (5m included)	4 x 0,75 (5m included)	4 x 0,75 (5m included)	4 x 0,75 (5m included)	
Recommended power cable		mm²	3x1,5	3x1,5	3x2,5	3x2,5	
Recommended air switch		A	10	10	16	16	
EQUIPMENT							
Plasma generator	indoor		✓	✓	✓	✓	
Wifi module			✓	✓	✓	✓	
Drain pump			-	-	-	-	
Max. lift (from bottom of ID unit)		mm	-	-	-	-	
Dry contact (ON/OFF)			-	-	-	-	
Alarm contact			-	-	-	-	
Fresh air inlet			-	-	-	-	
Throttling method	outdoor		Capillary	Capillary	Capillary	EXV	
Bottom chassis heater			-	-	-	-	
Crankcase heater			Preheating	Preheating	Preheating	Preheating	
Bottom plugs for OD			✓	✓	✓	✓	
Drain pipe connector			✓	✓	✓	✓	
STANDARD ACCESSORIES							
Standard health filter			SAF-OPWA4, SAF-OPWC4				
Remote controller (IR)			YAN1F6 (wifi)	YAN1F6 (wifi)	YAN1F6 (wifi)	YAN1F6 (wifi)	
Wired controller			-	-	-	-	
OPTIONAL ACCESSORIES							
Optional health filters			SAF-OPWB4, SAF-OPWK4, SAF-OPWM4, SAF-OPWP4, SAF-OPWS4				
Wired controller			-	-	-	-	
Central controller			-	-	-	-	
Other			G25, G25-T, SAI-01	G25, G25-T, SAI-01	G25, G25-T, SAI-01	G25, G25-T, SAI-01	

The specification of products is subject to change based on further development of the units by the producer and can be changed without prior notice. Refer to rating label.

R32 (single component refrigerant HFC), GWP of refrigerant used: 675.

Contains fluorinated greenhouse gases covered by the Kyoto Protocol.

Explanatory notes on the very last page of the catalogue.

The device is being sold as a set (indoor + outdoor unit).

APPEARANCE AND DIMENSIONS OF INDOOR UNIT

VISION SERIES

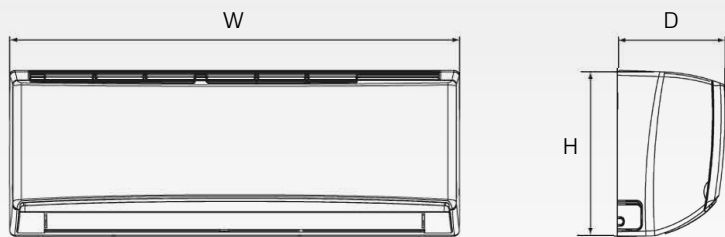

ASH-09BIV, ASH-12BIV

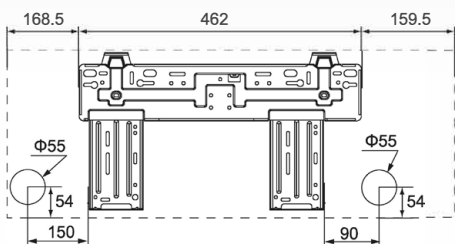

ASH-18BIV, ASH-24BIV

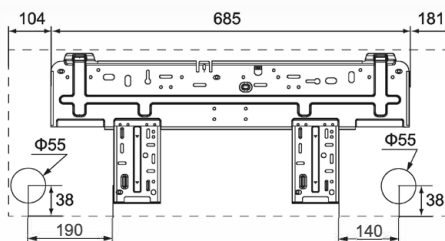

units: mm

APPEARANCE AND DIMENSIONS OF OUTDOOR UNIT

VISION SERIES

ASH-09BIV

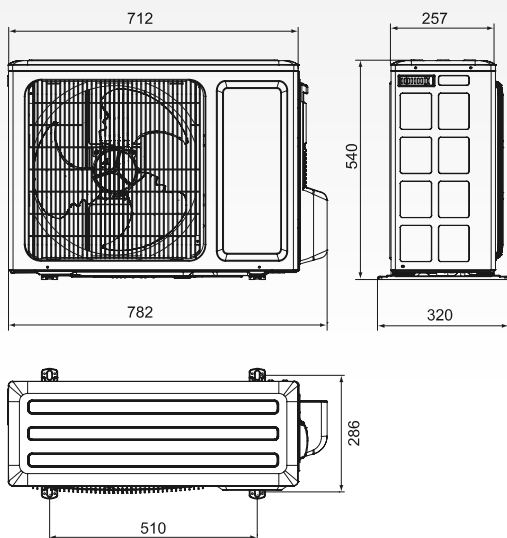

ASH-12BIV, ASH-18BIV

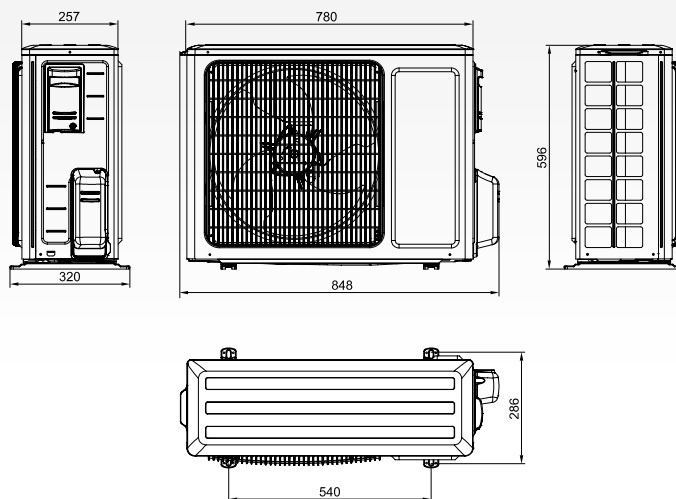

units: mm

ASH-24BIV

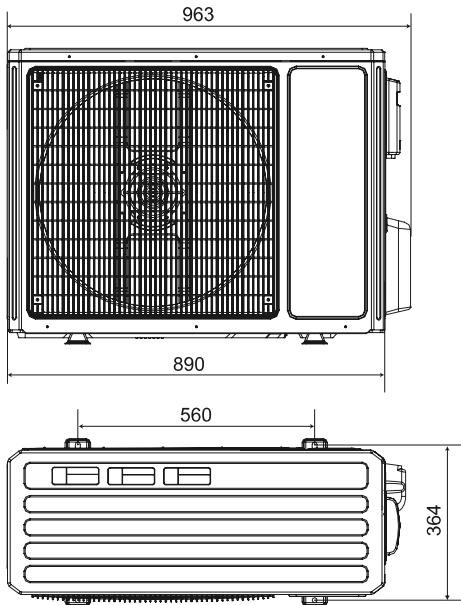

units: mm

ELECTRICAL WIRING DIAGRAM

VISION SERIES

INDOOR UNIT

OUTDOOR UNIT

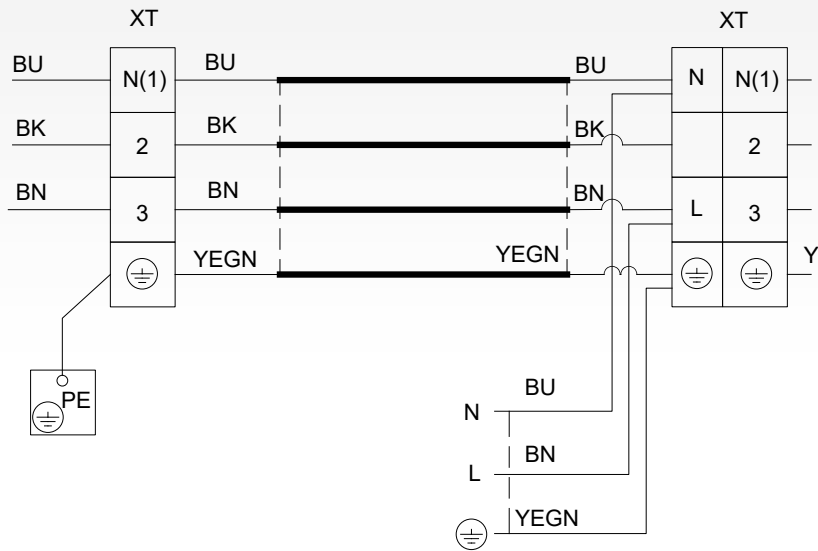

WALL MOUNTED SPLIT AIR CONDITIONERS

FOCUS PLUS SERIES

MODEL			ASH-09BIF2	ASH-13BIF2	ASH-18BIF2	ASH-24BIF2	
Capacity cooling/heating 1)	Nominal (min-max)	kW	2,7 (0,5-3,5) / 2,8 (0,5-4,2)	3,5 (0,7-4,0) / 3,7 (0,8-4,5)	5,2 (1,3-6,6) / 5,3 (1,2-6,8)	7,0 (2,0-8,9) / 7,4 (1,8-10,7)	
Power supply		Hz / V	1~ / 50 / 220-240	1~ / 50 / 220-240	1~ / 50 / 220-240	1~ / 50 / 220-240	
Power supply		-	outdoor	outdoor	outdoor	outdoor	
Power input cooling/heating 1)		W	820 / 755	1085 / 990	1528 / 1410	1900 / 1897	
Maximal power input 2)		W	1500	1500	2600	3750	
Power current cooling/heating		A	3,8 / 3,5	5,0 / 4,5	6,8 / 6,3	8,8 / 8,9	
Maximal power current 2)		A	6,3	6,6	10,9	17,5	
Energy class cooling 3)		-	A++	A++	A++	A++	
Pdesign cooling		kW	2,7	3,5	5,2	7,0	
SEER		-	6,8	7,0	7,0	6,5	
Annual power consumption		kWh / annum	139	175	260	377	
Energy class heating 3)	Aver./Warm./Cool.	-	A+ / A+++ / B	A+ / A+++ / B	A+ / A+++ / A	A+ / A+++ / B	
Pdesign heating	Average climate	kW	2,6	3,0	4,2	6,4	
SCOP	Average climate	-	4,0	4,0	4,0	4,0	
Annual power consumption	Average climate	kWh / annum	910	1050	1470	2240	
Air flow of ID	SH/MH/H/ML/ML/SL	m³ / h	560/490/460/430/380/330/290	680/620/560/490/450/420/390	800/720/650/610/570/520/470	660/590/540/490/450/420/390	
Airflow of OD	H	m³ / h	1600	2200	3200	3200	
Sound pressure level of ID at 1m 4)	SH/MH/H/ML/ML/SL	dB(A)	41/37/35/32/29/26/24	42/38/35/32/30/28/26	45/43/41/38/35/34/31	48/45/42/39/37/36/33	
Sound pressure level of OD at 1m 4)	H	dB(A)	50	52	57	57	
Sound power of ID 4)	SH/MH/H/ML/ML/SL	dB(A)	55/48/46/44/40/37/35	57/50/47/44/42/40/38	59/57/55/52/49/48/45	63/60/57/54/57/51/48	
Sound power of OD 4)	H	dB(A)	59	62	64	67	
Dehumidifying volume		l / h	0,8	1,4	1,8	2,4	
Refrigerant type/charge		Type / kg / t eq. CO ₂	R32 / 0,55 / 0,37	R32 / 0,70 / 0,47	R32 / 1,00 / 0,68	R32 / 1,70 / 1,15	
Additional refrigerant		g / m	16	16	16	16	
Pipe diameter - liquid side 5)		inch / mm	¼ / 6,0	¼ / 6,0	¼ / 6,0	¼ / 6,0	
Pipe diameter - gas side 5)		inch / mm	¾ / 9,5	¾ / 9,5	¾ / 12,0	¾ / 16,0	
Max pipe length without additional refrigerant 6)		m	5	5	5	5	
Allowed pipe length 7)	min./max.	m	3 / 15	3 / 20	3 / 25	3 / 25	
Max. elevation/ Drop height		m	10	10	10	10	
Dimension of ID	w x h x d	mm	790x275x200	845x289x209	970x300x224	1078x325x246	
Dimensions of outdoor unit	w x h x d	mm	782x540x320	848x596x320	963x700x396	963x700x396	
Package dimension of ID	w x h x d	mm	866x367x271	921x379x281	1041x320x383	1145x335x410	
Package dimensions of outdoor unit	w x h x d	mm	823x595x358	881x645x363	1029x750x458	1029x750x458	
Weight of ID	netto / brutto	kg	9,0 / 11,0	10,5 / 12,5	13,5 / 16,5	16,5 / 20	
Weight of OD	netto / brutto	kg	27,5 / 30,0	31,0 / 34,0	45 / 49,5	53,5 / 58	
Set temperature range		°C	16 ~ 30	16 ~ 30	16 ~ 30	16 ~ 30	
Operating temperature range cooling 8)		°C	-15 ~ 43	-15 ~ 43	-15 ~ 43	-15 ~ 43	
Operating temperature range heating 8)		°C	-22 ~ 24	-22 ~ 24	-22 ~ 24	-22 ~ 24	
ADDITIONAL TECHNICAL INFORMATION							
Screw holes distance of OD	w x d	mm	510x286	540x286	560x364	560x364	
Communication cable		mm²	4 x 0,75 (5m included)				
Recommended power cable		mm²	3x1,5	3x1,5	3x2,5	3x4,0	
Recommended air switch		A	10	10	16	20	
EQUIPMENT							
Plasma generator	indoor		✓	✓	✓	✓	
Wifi module			✓	✓	✓	✓	
Drain pump			-	-	-	-	
Max. lift (from bottom of ID unit)		mm	-	-	-	-	
Dry contact (ON/OFF)			✓	✓	✓	✓	
Alarm contact			-	-	-	-	
Fresh air inlet			-	-	-	-	
Throttling method	outdoor		Capillary	EXV	EXV	EXV	
Bottom chassis heater			Heating belt	Heating belt	Heating belt	Heating belt	
Crankcase heater			Preheating	Preheating	Preheating	Preheating	
Bottom plugs for OD			-	-	✓	✓	
Drain pipe connector			✓	✓	✓	✓	
STANDARD ACCESSORIES							
Standard health filter			SAF-OPWC4, SAF-OPWB4				
Remote controller (IR)			YAC1FB9	YAC1FB9	YAC1FB9	YAC1FB9	
Wired controller			-	-	-	-	
OPTIONAL ACCESSORIES							
Optional health filters			SAF-OPWC4, SAF-OPWK4, SAF-OPWM4, SAF-OPWPA4, SAF-OPWS4				
Wired controller			SWC-02, XK19				
Central controller			SCC-16, SCC-36				
Other			G2S, G2S-T, SAI-01				

The specification of products is subject to change based on further development of the units by the producer and can be changed without prior notice. Refer to rating label.

R32 (single component refrigerant HFC), GWP of refrigerant used: 675.

Contains fluorinated greenhouse gases covered by the Kyoto Protocol.

Explanatory notes on the very last page of the catalogue.

The device is being sold as a set (indoor + outdoor unit).

APPEARANCE AND DIMENSIONS OF INDOOR UNIT

FOCUS PLUS SERIES

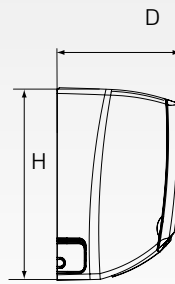
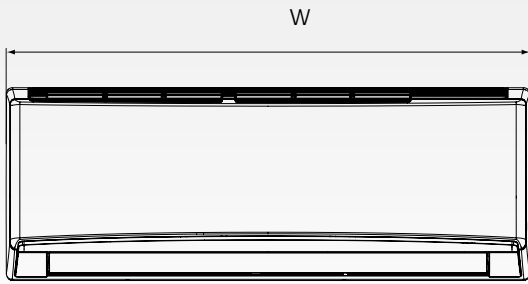

ASH-09BIF2

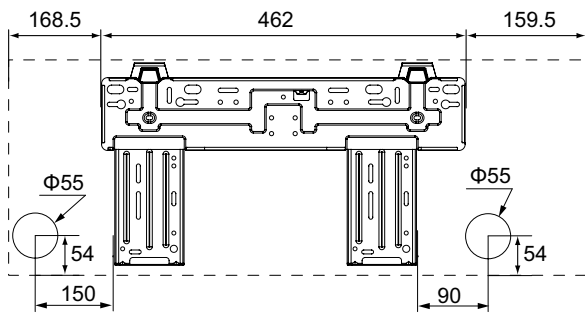

ASH-13BIF2

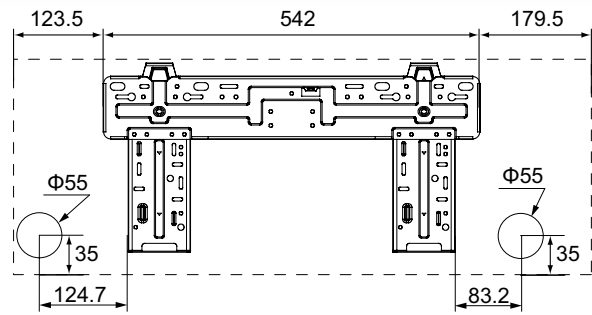

ASH-18BIF2

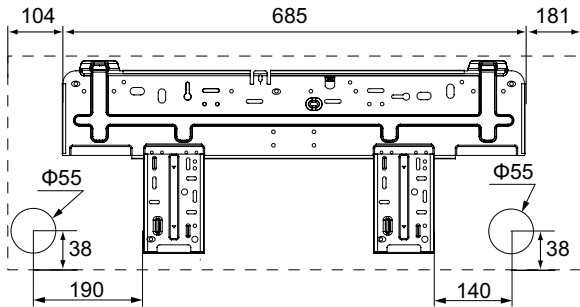

ASH-24BIF2

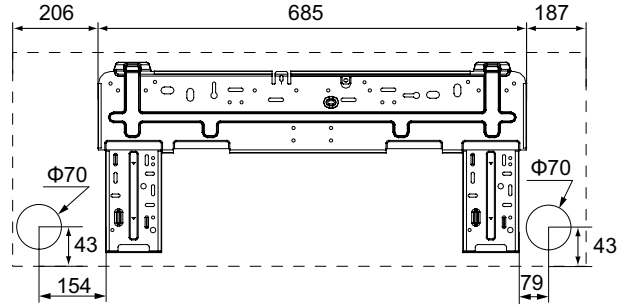

units: mm

DIMENSIONS OF OUTDOOR UNIT

FOCUS PLUS SERIES

ASH-09BIF2

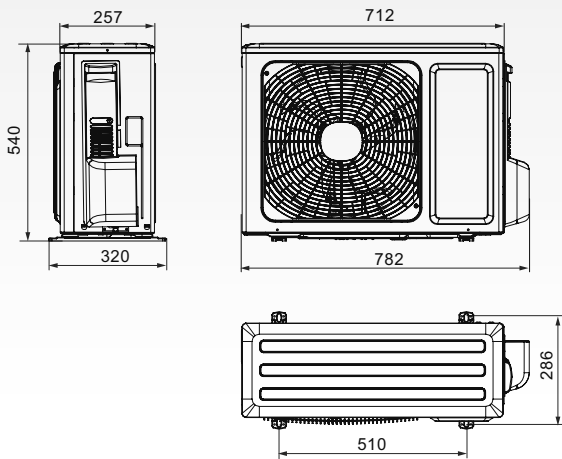

ASH-13BIF2

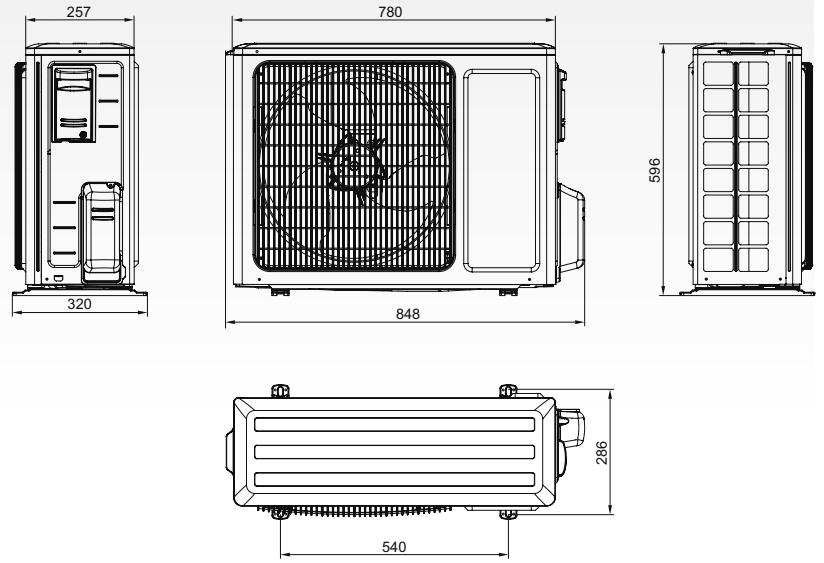

ASH-18BIF2, ASH-24BIF2

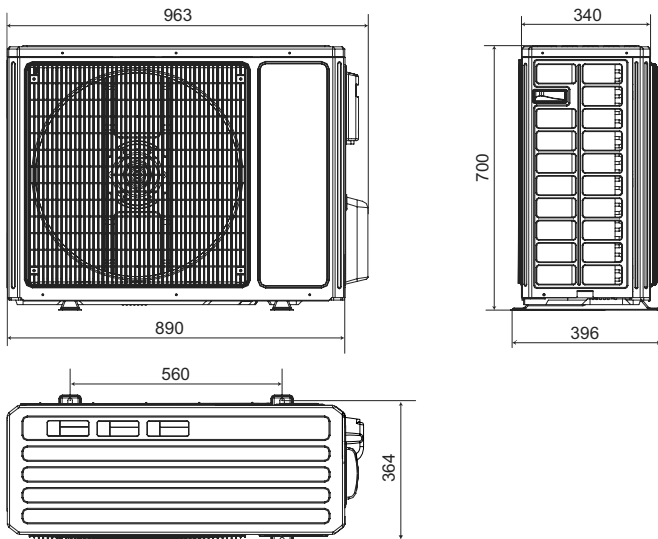

units: mm

ELECTRICAL WIRING DIAGRAM

FOCUS PLUS SERIES

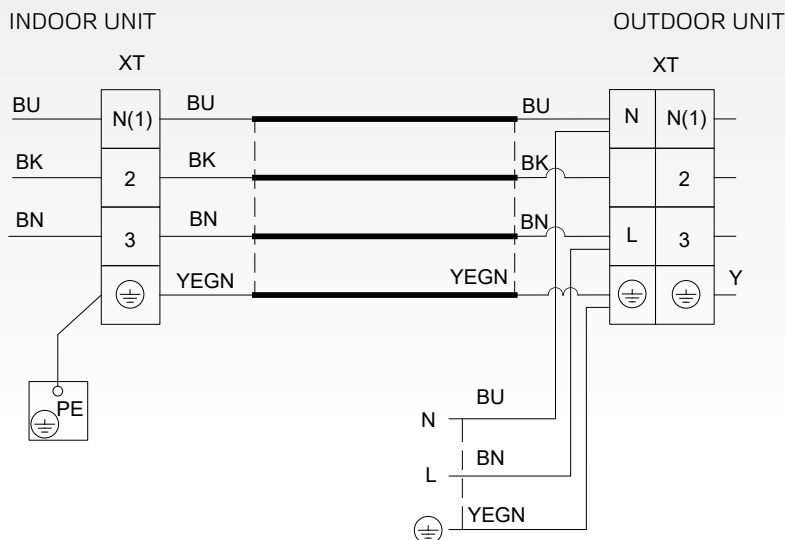

WALL MOUNTED SPLIT AIR CONDITIONERS

SPECTRUM SERIES

MODEL			ASH-09BIS/W, ASH-09BIS/B	ASH-13BIS/W, ASH-13BIS/B	ASH-18BIS/W, ASH-18BIS/B	ASH-24BIS/W, ASH-24BIS/B	
Capacity cooling/heating 1)	Nominal (min-max)	kW	2,7 (0,9-3,8) / 3,0 (0,7-4,4)	3,5 (1,0-3,8) / 3,8 (1,2-4,4)	5,3 (1,3-6,6) / 5,6 (1,2-6,8)	7,0 (1,1-9,1) / 7,2 (1,7-10,1)	
Power supply		Hz / V	1~ / 50 / 220-240	1~ / 50 / 220-240	1~ / 50 / 220-240	1~ / 50 / 220-240	
Power supply		-	outdoor	outdoor	outdoor	outdoor	
Power input cooling/heating 1)		W	585 / 650	950 / 975	1550 / 1428	2000 / 1845	
Maximal power input 2)		W	1650	1650	2600	3800	
Power current cooling/heating		A	2,6 / 2,9	4,0 / 4,5	6,9 / 6,3	9,2 / 8,5	
Maximal power current 2)		A	6,4	6,4	10,9	16,5	
Energy class cooling 3)		-	A+++	A+++	A++	A++	
Pdesign cooling		kW	2,7	3,5	5,3	7,0	
SEER		-	8,5	8,5	7,6	7,0	
Annual power consumption		kWh / annum	111	144	244	350	
Energy class heating 3)	Aver./Warm./Cool.	-	A++ / A+++ / A	A+ / A+++ / A	A+ / A+++ / A	A+ / A+++ / A	
Pdesign heating	Average climate	kW	2,8	3,2	4,5	6,4	
SCOP	Average climate	-	4,6	4,4	4,1	4,0	
Annual power consumption	Average climate	kWh / annum	852	1018	1537	2240	
Air flow of ID	SH/MH/H/ML/ML/SL	m³ / h	660/590/540/490/450/420/390	680/590/540/490/450/420/390	850/750/610/520	1250/1100/1000/950/900/850/750	
Airflow of OD	H	m³ / h	2200	2200	3200	3200	
Sound pressure level of ID at 1m 4)	SH/MH/H/ML/ML/SL	dB(A)	41/39/37/35/33/31/24	43/39/37/35/34/32/25	49/45/43/41/39/37/34	49/47/44/42/40/38/36	
Sound pressure level of OD at 1m 4)	H	dB(A)	52	53	57	60	
Sound power of ID 4)	SH/MH/H/ML/ML/SL	dB(A)	56/53/52/50/48/46/39	58/53/52/50/48/46/40	58/55/53/51/49/47/44	65/61/58/56/54/52/50	
Sound power of OD 4)	H	dB(A)	60	62	65	70	
Dehumidifying volume		l / h	0,8	1,4	1,8	2,4	
Refrigerant type/charge		Type / kg / t eq. CO ₂	R32 / 0,70 / 0,47	R32 / 0,75 / 0,54	R32 / 1,00 / 0,67	R32 / 1,70 / 1,15	
Additional refrigerant		g / m	16	16	16	50	
Pipe diameter - liquid side 5)		inch / mm	¼ / 6,0	¼ / 6,0	¼ / 6,0	¼ / 6,0	
Pipe diameter - gas side 5)		inch / mm	¾ / 9,5	¾ / 9,5	¾ / 12,0	¾ / 16,0	
Max pipe length without additional refrigerant 6)		m	5	5	5	5	
Allowed pipe length 7)	min./max.	m	3 / 15	3 / 20	3 / 25	3 / 25	
Max. elevation / Drop height		m	10	10	10	10	
Dimension of ID	w x h x d	mm	865x290x210	865x290x210	996x301x225	1101x327x249	
Dimensions of outdoor unit	w x h x d	mm	848x596x320	848x596x320	965x700x396	963x700x396	
Package dimension of ID	w x h x d	mm	931x281x379	931x281x379	1060x380x322	1167x405x354	
Package dimensions of outdoor unit	w x h x d	mm	881x645x363	881x645x363	1029x750x458	1029x750x458	
Weight of ID	netto / brutto	kg	10,5 / 12,5	11,0 / 13,0	13,5 / 16,5	16,5 / 20	
Weight of OD	netto / brutto	kg	33,5 / 36,5	33,5 / 36,5	45,0 / 49,5	53,0 / 57,5	
Set temperature range		°C	16 ~ 30	16 ~ 30	16 ~ 30	16 ~ 30	
Operating temperature range cooling 8)		°C	-15 ~ 43	-15 ~ 43	-15 ~ 43	-15 ~ 43	
Operating temperature range heating 8)		°C	-22 ~ 24	-22 ~ 24	-22 ~ 24	-22 ~ 24	
ADDITIONAL TECHNICAL INFORMATION							
Screw holes distance of OD	w x d	mm	540x286	540x286	560x364	560x396	
Communication cable		mm²	4 x 0,75 (5m included)				
Recommended power cable		mm²	3x1,5	3x1,5	3x2,5	3x4,0	
Recommended air switch		A	10	10	16	20	
EQUIPMENT							
Plasma generator	indoor		✓	✓	✓	✓	
Wifi module			✓	✓	✓	✓	
Drain pump			-	-	-	-	
Max. lift (from bottom of ID unit)		mm		-	-	-	-
Dry contact (ON/OFF)				✓	✓	✓	✓
Alarm contact				-	-	-	-
Fresh air inlet				-	-	-	-
Throttling method	outdoor		EXV	EXV	EXV	EXV	
Bottom chassis heater			Heating belt	Heating belt	Heating belt	Heating belt	
Crankcase heater			Heating belt	Heating belt	Preheating	Preheating	
Bottom plugs for OD				✓	✓	✓	✓
Drain pipe connector				✓	✓	✓	✓
STANDARD ACCESSORIES							
Standard health filter			SAF-OPWC4, SAF-OPWS4				
Remote controller (IR)			YAG1FB	YAG1FB	YAG1FB	YAG1FB	
Wired controller			-	-	-	-	
OPTIONAL ACCESSORIES							
Optional health filters			SAF-OPWA4, SAF-OPWB4, SAF-OPWK4, SAF-OPWM4, SAF-OPWP4				
Wired controller			SWC-02, XK19				
Central controller			SCC-16, SCC-36				
Other			G2S, G2S-T, SAI-01				

The specification of products is subject to change based on further development of the units by the producer and can be changed without prior notice. Refer to rating label.

R32 (single component refrigerant HFC), GWP of refrigerant used: 675.

Contains fluorinated greenhouse gases covered by the Kyoto Protocol.

Explanatory notes on the very last page of the catalogue.

The device is being sold as a set (indoor + outdoor unit).

APPEARANCE AND DIMENSIONS OF INDOOR UNIT

SPECTRUM SERIES

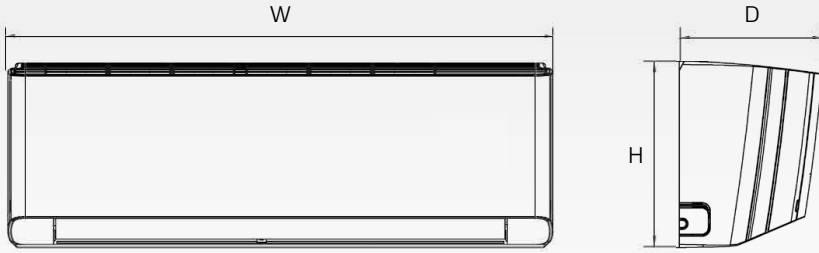

ASH-09BIS/W, ASH-09BIS/B, ASH-13BIS/W, ASH-13BIS/B

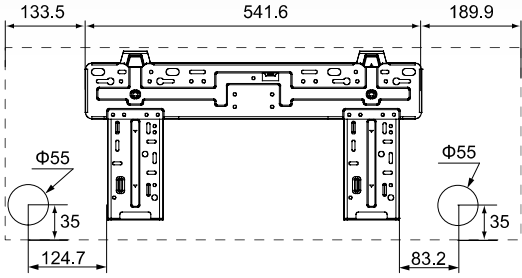

ASH-18BIS/W, ASH-18BIS/B

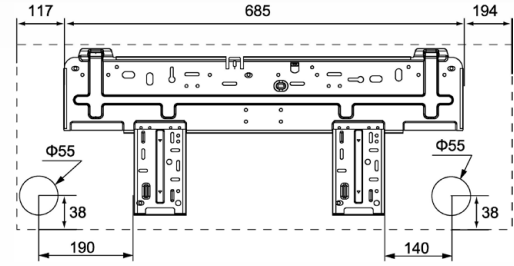

ASH-24BIS/W, ASH-24BIS/B

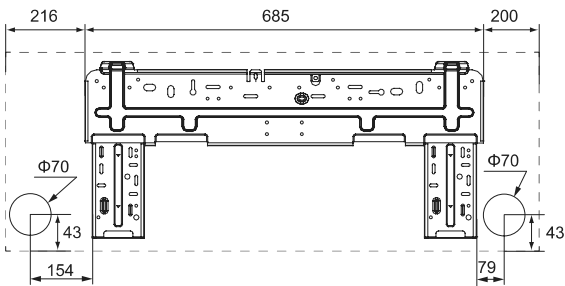

units: mm

APPEARANCE AND DIMENSIONS OF OUTDOOR UNIT

SPECTRUM SERIES

ASH-09BIS/W, ASH-09BIS/B, ASH-13BIS/W, ASH-13BIS/B

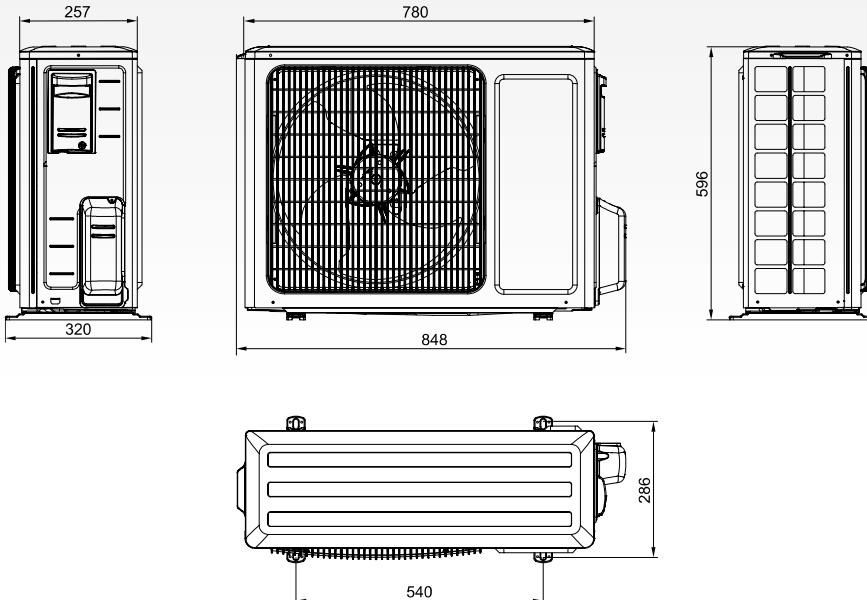

units: mm

ASH-18BIS/W, ASH-18BIS/B

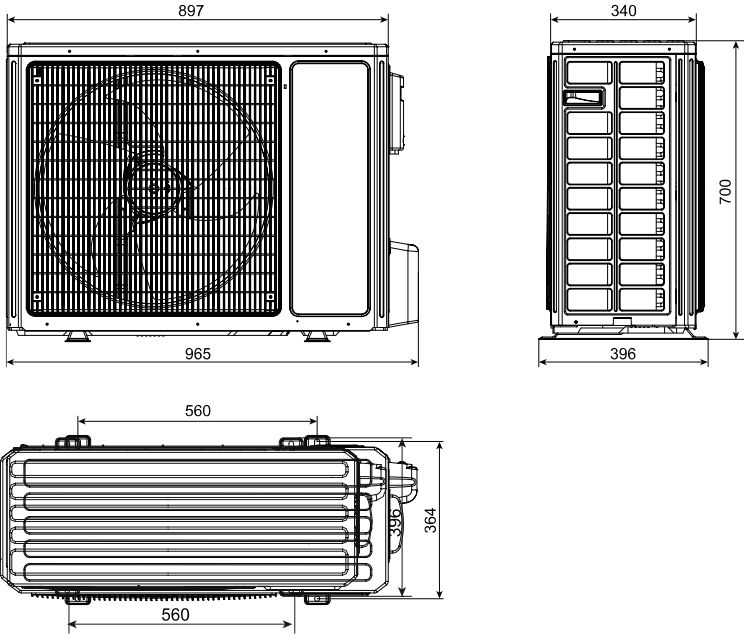

ASH-24BIS/W, ASH-24BIS/B

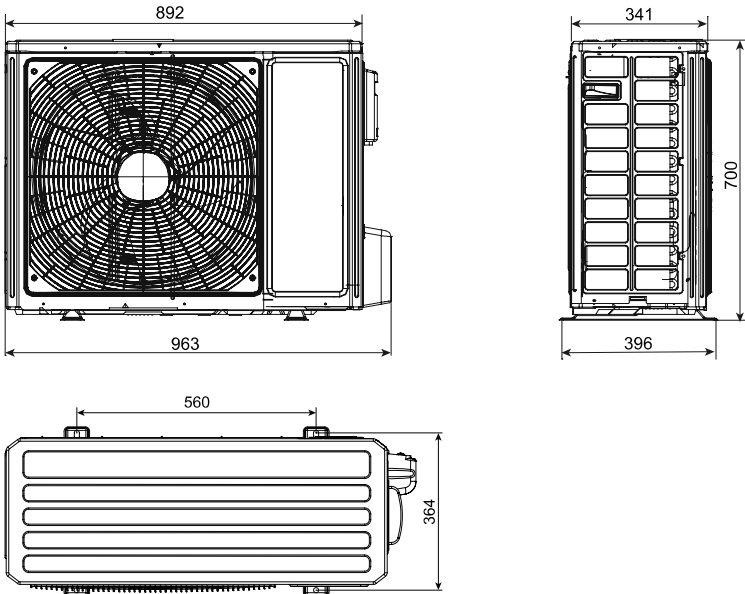

units: mm

ELECTRICAL WIRING DIAGRAM

SPECTRUM SERIES

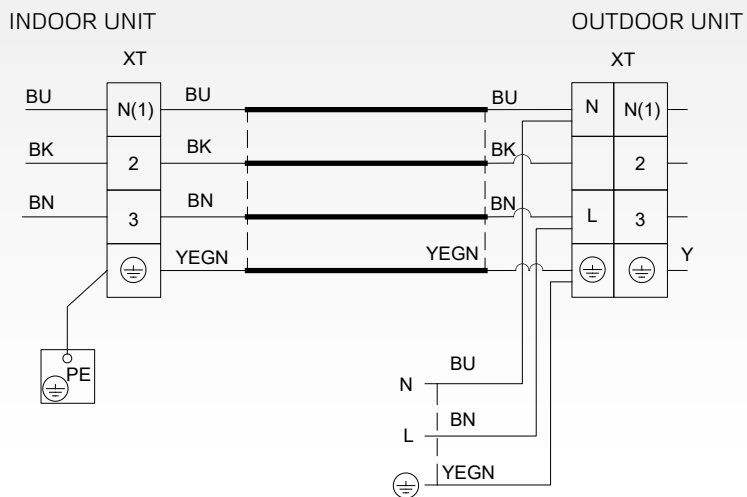

WALL MOUNTED SPLIT AIR CONDITIONERS

SPECTRUM PLUS SERIES

MODEL			ASH-09BIS2/WE	ASH-13BIS2/WE	ASH-18BIS2/WE	ASH-24BIS2/WE	
Capacity cooling/heating 1)	Nominal (min-max)	kW	2,7 (0,7-5,0) / 3,5 (0,7-5,5)	3,6 (0,9-5,0) / 4,2 (0,9-7,2)	5,3 (1,2-7,2) / 6,2 (1,2-9,2)	7,1 (2,0-9,5) / 7,1 (2,0-9,5)	
Power supply		Hz / V	1~ / 50 / 220-240	1~ / 50 / 220-240	1~ / 50 / 220-240	1~ / 50 / 220-240	
Power supply		-	outdoor	outdoor	outdoor	outdoor	
Power input cooling/heating 1)		W	550 / 745	840 / 950	1180/1450	1850 / 1750	
Maximal power input 2)		W	2400	2600	3200	3800	
Power current cooling/heating		A	3,6 / 4,7	5,1 / 5,7	5,9/5,9	11,0/11,0	
Maximal power current 2)		A	8,0	8,2	13,0	16,4	
Energy class cooling 3)		-	A+++	A+++	A++	A++	
Pdesign cooling		kW	2,7	3,5	5,3	7,0	
SEER		-	8,5	8,5	7,5	6,5	
Annual power consumption		kWh / annum	111	144	247	377	
Energy class heating 3)	Aver./Warm./Cool.	-	A+++ / A+++ / A	A+++ / A+++ / A+	A+ / A+++ / A	A+ / A+++ / A	
Pdesign heating	Average climate	kW	3,5	3,5	5,9	7,0	
SCOP	Average climate	-	5,1	5,1	4,4	4,1	
Annual power consumption	Average climate	kWh / annum	961	961	1877	2390	
Air flow of ID	SH/MH/H/ML/ML/SL	m³ / h	800/730/680/630/580/450/350	800/730/680/630/580/450/350	1200/1150/1050/950/850/780/600	1200/1050/950/900/850/800/750	
Airflow of OD	H	m³ / h	2400	2400	4000	4000	
Sound pressure level of ID at 1m 4)	SH/MH/H/ML/ML/SL	dB(A)	44/43/38/36/31/24/22	44/43/38/36/31/24/22	46/44/42/39/36/34/32	50/46/43/41/39/37/35	
Sound pressure level of OD at 1m 4)	H	dB(A)	53	54	56	58	
Sound power of ID 4)	SH/MH/H/ML/ML/SL	dB(A)	58/53/48/46/41/34/32	58/53/48/46/41/34/32	60/54/52/49/46/44/42	64/60/57/55/53/51/49	
Sound power of OD 4)	H	dB(A)	62	62	63	69	
Dehumidifying volume		l / h	0,8	1,4	1,8	2,0	
Refrigerant type/charge		Type / kg / t eq. CO ₂	R32 / 1,00 / 0,67	R32 / 1,00 / 0,67	R32 / 1,50 / 1,01	R32 / 2,00 / 1,35	
Additional refrigerant		g / m	16	16	40	50	
Pipe diameter - liquid side 5)		inch / mm	¼ / 6,0	¼ / 6,0	¼ / 6,0	¼ / 6,0	
Pipe diameter - gas side 5)		inch / mm	¾ / 9,5	¾ / 9,5	¾ / 16,0	¾ / 16	
Max pipe length without additional refrigerant 6)		m	5	5	5	7,5	
Allowed pipe length 7)	min./max.	m	3 / 15	3 / 20	3 / 40	3 / 50	
Max. elevation/ Drop height		m	10	10	20	30	
Dimension of ID	w x h x d	mm	996x301x225	996x301x225	1101x327x249	1101x327x249	
Dimensions of outdoor unit	w x h x d	mm	899x596x378	899x596x378	980x790x427	1003x790x427	
Package dimension of ID	w x h x d	mm	1060x380x322	1060x380x322	1167x405x354	1167x405x354	
Package dimensions of outdoor unit	w x h x d	mm	948x420x645	948x420x645	1083x488x855	1083x488x855	
Weight of ID	netto / brutto	kg	13,0 / 16,0	13,5 / 16,5	16,5 / 20,0	16,5 / 20,0	
Weight of OD	netto / brutto	kg	44,5 / 47,5	45,5 / 48,5	61,0 / 66,0	65,0 / 70,0	
Set temperature range		°C	16 ~ 30	16 ~ 30	16 ~ 30	16 ~ 30	
Operating temperature range cooling 8)		°C	-18 ~ 52	-18 ~ 52	-18 ~ 52	-18 ~ 52	
Operating temperature range heating 8)		°C	-30 ~ 24	-30 ~ 24	-30 ~ 24	-30 ~ 24	
ADDITIONAL TECHNICAL INFORMATION							
Screw holes distance of OD	w x d	mm	550x354	550x354	610x395	610x395	
Communication cable		mm²	4 x 0,75 (5m included)				
Recommended power cable		mm²	3x1,5	3x1,5	3x2,5	3x4,0	
Recommended air switch		A	13	13	16	20	
EQUIPMENT							
Plasma generator	indoor		✓	✓	✓	✓	
Wifi module			✓	✓	✓	✓	
Drain pump			-	-	-	-	
Max. lift (from bottom of ID unit)		mm	-	-	-	-	
Dry contact (ON/OFF)			✓	✓	✓	✓	
Alarm contact			-	-	-	-	
Fresh air inlet			-	-	-	-	
Throttling method	outdoor		EXV	EXV	EXV	EXV	
Bottom chassis heater			Heating belt	Heating belt	Heating belt	Heating belt	
Crankcase heater			Preheating	Preheating	Preheating	Preheating	
Bottom plugs for OD			✓	✓	✓	✓	
Drain pipe connector			✓	✓	✓	✓	
STANDARD ACCESSORIES							
Standard health filter			SAF-OPWC4, SAF-OPWS4				
Remote controller (IR)			YAG1FB2	YAG1FB2	YAG1FB2	YAG1FB2	
Wired controller			-	-	-	-	
OPTIONAL ACCESSORIES							
Optional health filters			SAF-OPWA4, SAF-OPWB4, SAF-OPWK4, SAF-OPWM4, SAF-OPWP4				
Wired controller			SWC-02, XK19	SWC-02, XK19	SWC-02, XK19	SWC-02, XK19	
Central controller			SCC-16, SCC-36	SCC-16, SCC-36	SCC-16, SCC-36	SCC-16, SCC-36	
Other			G2S, G2S-T, SAI-01	G2S, G2S-T, SAI-01	G2S, G2S-T, SAI-01	G2S, G2S-T, SAI-01	

The specification of products is subject to change based on further development of the units by the producer and can be changed without prior notice. Refer to rating label.

R32 (single component refrigerant HFC), GWP of refrigerant used: 675.

Contains fluorinated greenhouse gases covered by the Kyoto Protocol.

Explanatory notes on the very last page of the catalogue.

The device is being sold as a set (indoor + outdoor unit).

APPEARANCE AND DIMENSIONS OF INDOOR UNIT

SPECTRUM PLUS SERIES

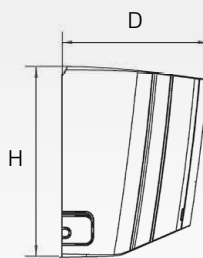
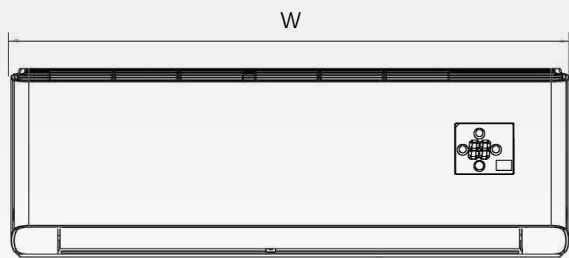

ASH-09BIS2/WE

ASH-13BIS2/WE

ASH-18BIS2/WE

ASH-24BIS2/WE

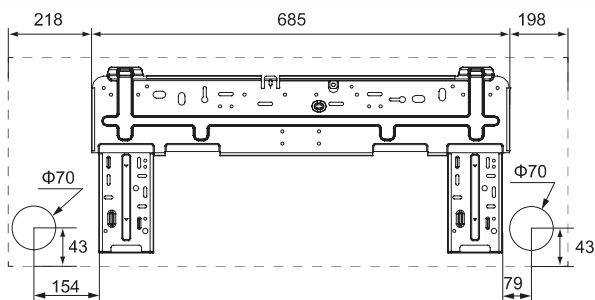
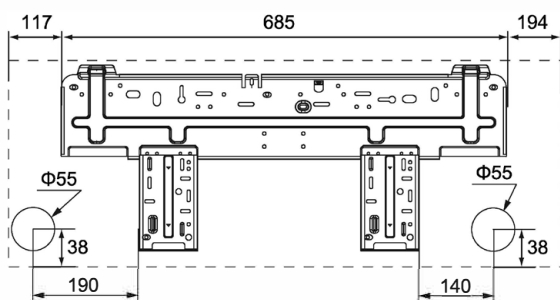

units: mm

APPEARANCE AND DIMENSIONS OF OUTDOOR UNIT

SPECTRUM PLUS SERIES

ASH-09BIS2/WE

ASH-13BIS2/WE

ASH-18BIS2/WE

ASH-24BIS2/WE

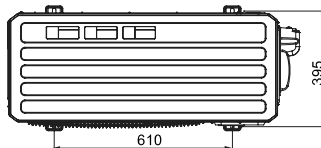
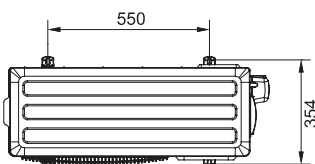
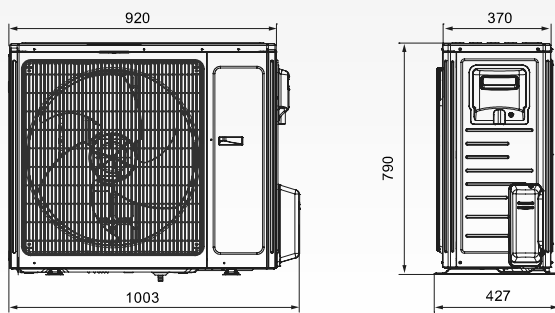
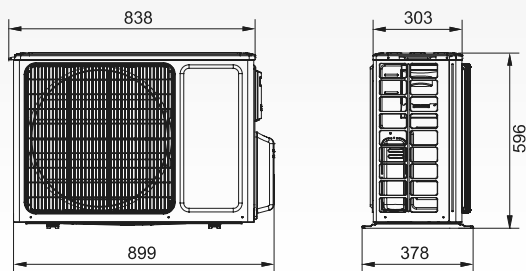

units: mm

ELECTRICAL WIRING DIAGRAM

SPECTRUM PLUS SERIES

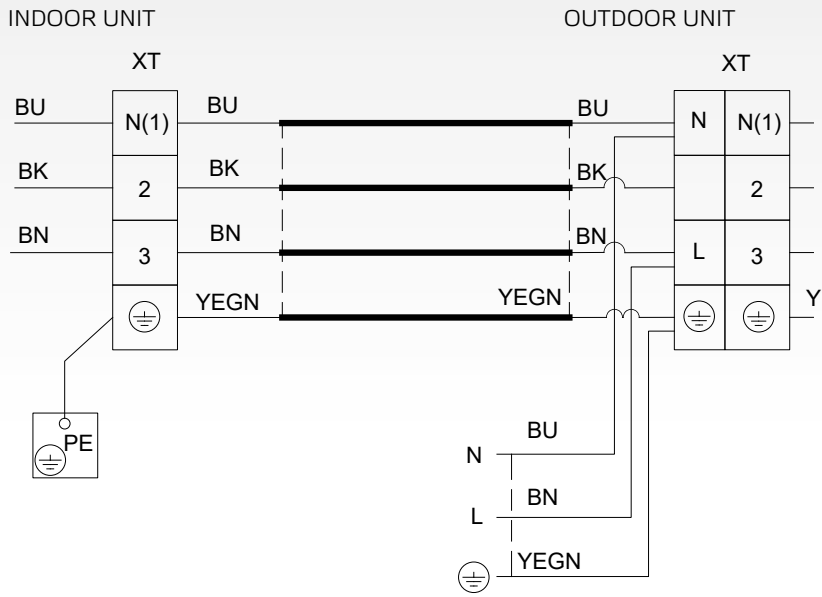

CONSOLE SPLIT AIR CONDITIONERS

CONSOLE SERIES

MODEL			ASP-09BI	ASP-12BI	ASP-18BI		
Capacity cooling/heating 1)	Nominal (min-max)	kW	2,7 (0,7-3,4) / 2,9(0,6-3,5)	3,5(0,8-4,4) / 3,8(1,1-4,4)	5,2(1,3-6,6) / 5,3(1,1-6,8)		
Power supply		Hz / V	1~ / 50 / 220-240	1~ / 50 / 220-240	1~ / 50 / 220-240		
Power supply		-	outdoor	outdoor	outdoor		
Power input cooling/heating 1)		W	720 / 730	1000/ 960	1550 / 1500		
Maximal power input 2)		W	1350	1500	2500		
Power current cooling/heating		A	3,50 / 3,60	4,48 / 4,30	7,1 / 6,7		
Maximal power current 2)		A	6,00	6,72	10,9		
Energy class cooling 3)		-	A++	A++	A++		
Pdesign cooling		kW	2,7	3,5	5,2		
SEER		-	7,2	7,0	6,6		
Annual power consumption		kWh / annum	131	175	276		
Energy class heating 3)	Aver./Warm./Cool.	-	A+ / A+++ / -	A+ / A+++ / -	A+ / A+++ / -		
Pdesign heating	Average climate	kW	2,6	3,2	5,0		
SCOP	Average climate	-	4,0	4,1	4,1		
Annual power consumption	Average climate	kWh / annum	910	1093	1707		
Air flow of ID	SH/MH/H/ML/ML/SL	m³ / h	500/430/410/370/330/280/250	600/520/480/440/400/360/280	700/650/580/520/460/410/320		
Airflow of OD	H	m³ / h	1600	2200	3200		
Sound pressure level of ID at 1m 4)	SH/MH/H/ML/ML/SL	dB(A)	39/36/33/31/29/26/23	42/40/38/36/34/31/25	47/45/43/41/38/37/32		
Sound pressure level of OD at 1m 4)	H	dB(A)	49	52	57		
Sound power of ID 4)	SH/MH/H/ML/ML/SL	dB(A)	50/48/45/44/42/38/34	52/50/48/46/43/39/35	57/55/53/51/48/47/42		
Sound power of OD 4)	H	dB(A)	60	62	65		
Dehumidifying volume		l / h	0,8	1,2	1,8		
Refrigerant type/charge		Type / kg / t eq. CO ₂	R32 / 0,55 / 0,37	R32 / 0,75 / 0,51	R32 / 0,95 / 0,64		
Additional refrigerant		g / m	16	16	16		
Pipe diameter - liquid side 5)		inch / mm	¼ / 6,0	¼ / 6,0	¼ / 6,0		
Pipe diameter - gas side 5)		inch / mm	¾ / 9,5	¾ / 9,5	¾ / 12,0		
Max pipe length without additional refrigerant 6)		m	5	5	5		
Allowed pipe length 7)	Min/Max	m	3 / 20	3 / 20	3 / 25		
Max. elevation/ Drop height		m	10	10	10		
Dimension of ID	w x h x d	mm	700x600x215	700x600x215	700x600x215		
Dimensions of outdoor unit	w x h x d	mm	782x540x320	848x596x320	965x700x396		
Package dimension of ID	w x h x d	mm	785x682x280	785x682x280	785x682x280		
Package dimensions of outdoor unit	w x h x d	mm	823x595x358	881x645x363	1026x455x735		
Weight of ID	netto / brutto	kg	15,5 / 18,5	15,5 / 18,5	15,5 / 18,5		
Weight of OD	netto / brutto	kg	27,5 / 30,0	30,5 / 33,5	46,0 / 50,5		
Set temperature range		°C	16-30	16-30	16-30		
Operating temperature range cooling 8)		°C	-15-43	-15-43	-15-43		
Operating temperature range heating 8)		°C	-22-24	-22-24	-22-24		
ADDITIONAL TECHNICAL INFORMATION							
Screw holes distance of OD	w x d	mm	510x286	540x286	560x364		
Communication cable		mm²	4 x 0,75 (5m included)				
Recommended power cable		mm²	3x1,5	3x1,5	3x2,5		
Recommended air switch		A	10	13	16		
EQUIPMENT							
Plasma generator	indoor		✓	✓	✓		
Wifi module			✓	✓	✓		
Drain pump			-	-	-		
Max. lift (from bottom of ID unit)		mm	-	-	-		
Dry contact (ON/OFF)			-	-	-		
Alarm contact			-	-	-		
Fresh air inlet			-	-	-		
Throttling method	outdoor		EXV	EXV	EXV		
Bottom chassis heater			Heating belt	Heating belt	Heating belt		
Crankcase heater			Preheating	Preheating	Preheating		
Bottom plugs for OD			-	-	✓		
Drain pipe connector			✓	✓	✓		
STANDARD ACCESSORIES							
Standard health filter			SAF-OPWA4, SAF-OPWC4				
Remote controller (IR)			YAA1FB8	YAA1FB8	YAA1FB8		
Wired controller			-	-	-		
OPTIONAL ACCESSORIES							
Optional health filters			SAF-OPWB4, SAF-OPWK4, SAF-OPWM4, SAF-OPWP4, SAF-OPWS4				
Wired controller			SWC-02, XK19				
Central controller			SCC-16, SCC-36				
Other			G2S, G2S-T				

The specification of products is subject to change based on further development of the units by the producer and can be changed without prior notice. Refer to rating label.

R32 (single component refrigerant HFC), GWP of refrigerant used: 675.

Contains fluorinated greenhouse gases covered by the Kyoto Protocol.

Explanatory notes on the very last page of the catalogue.

The device is being sold as a set (indoor + outdoor unit).

APPEARANCE AND DIMENSIONS OF INDOOR UNIT

CONSOLE SERIES

ASP-09BI, ASP-12BI, ASP-18BI

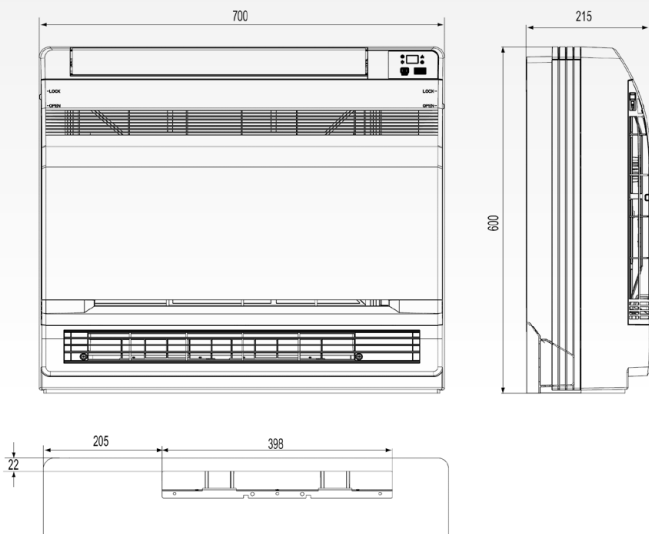

units: mm

DIMENSIONS OF OUTDOOR UNIT

CONSOLE SERIES

ASP-09BI

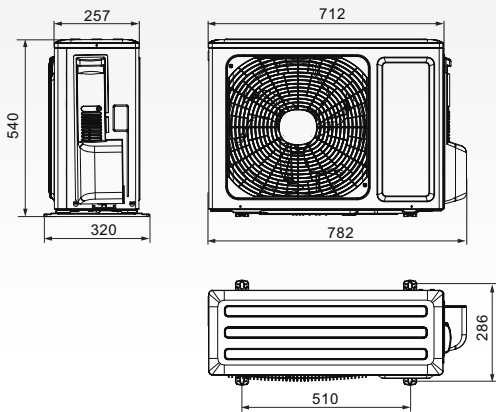

ASP-12BI

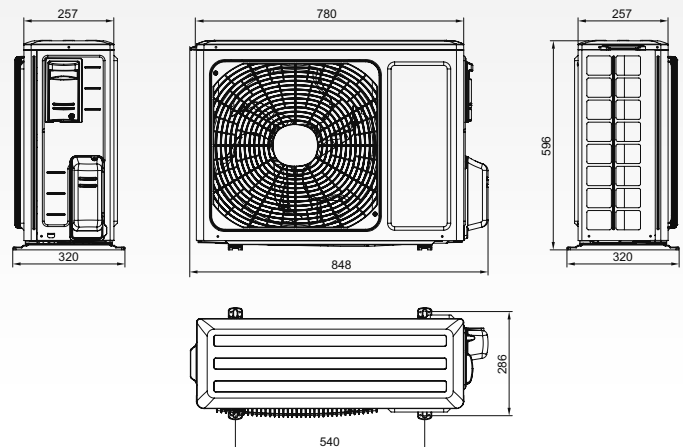

ASP-18BI

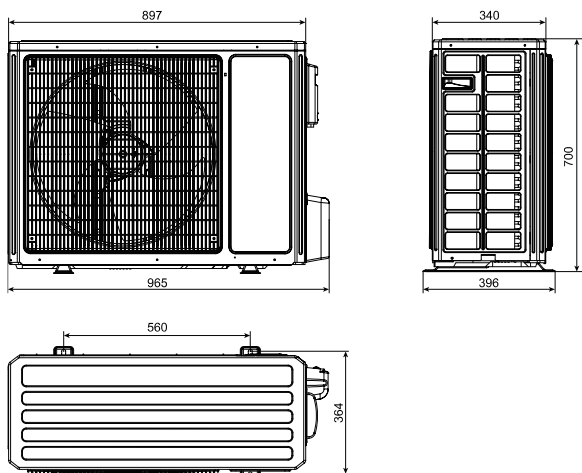

units: mm

ELECTRICAL WIRING DIAGRAM

CONSOLE SERIES

INDOOR UNIT

OUTDOOR UNIT

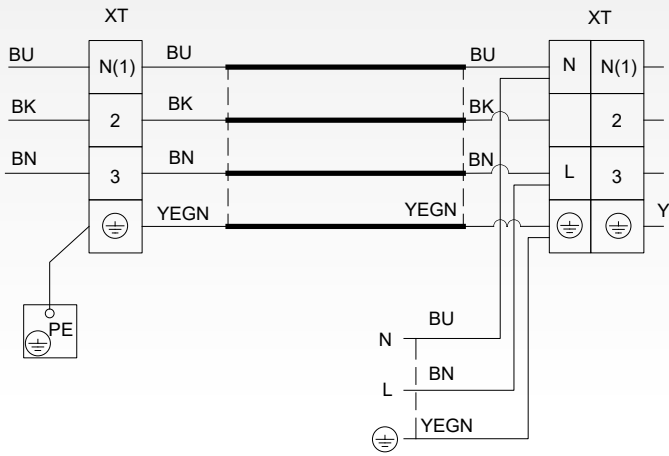

FLOOR-CEILING INDOOR UNITS

UNI SPLIT SERIES

MODEL			ASF-12BI / ASGE-12BI	ASF-18BI / ASGE-18BI	ASF-24BI / ASGE-24BI	ASF-30BI / ASGE-30BI	ASF-36BI / ASGE-36BI
Capacity cooling/heating 1)	Nominal	kW	3,5 (0,3-3,7) / 4,0 (0,7-4,1)	5,0 (0,6-5,3) / 5,5 (1,2-5,7)	7,0 (0,7-7,4) / 8,0 (1,8-8,3)	8,5 (1,0-8,9) / 8,8 (2,0-9,1)	10,0 (1,2-10,5) / 12,0 (2,5-12,4)
Power supply		Hz / V	1~ / 50 / 220-240	1~ / 50 / 220-240	1~ / 50 / 220-240	1~ / 50 / 220-240	1~ / 50 / 220-240
Energy class cooling 3)		-	A++	A++	A++	A++	A++
Pdesign cooling		kW	3,5	5,0	7,0	8,5	10,0
SEER		-	6,7	6,1	6,8	6,1	6,1
Annual power consumption		kWh / annum	177	284	359	477	573
Energy class heating 3)	Average climate	-	A+	A+	A	A+	A+
Pdesign heating	Average climate	kW	3,1	4,0	6,4	7,2	9,0
SCOP	Average climate	-	4,0	4,0	3,9	4,0	4,0
Annual power consumption	Average climate	kWh / annum	1040	1394	2295	2577	3149
Air flow of ID	H	m ³ / h	650	850	1300	1500	1600
Sound pressure of ID at 1m 4)	SH/H/M/L	dB(A)	39/36/32/28	44/42/39/36	45/44/41/38	49/47/45/43	49/47/45/43
Sound power of ID 4)	H	dB(A)	51	57	57	65	61
External static pressure	nom/min-max	Pa	-	-	-	-	-
Dehumidifying volume		l / h	-	-	-	-	-
Refrigerant type	Type		R32	R32	R32	R32	R32
Pipe diameter - liquid side 5)	inch / mm		¼ / 6,4	¼ / 6,4	¾ / 9,5	¾ / 9,5	¾ / 9,5
Pipe diameter - gas side 5)	inch / mm		¾ / 9,5	¾ / 12,7	¾ / 15,9	¾ / 15,9	¾ / 15,9
Dimension of ID	w x h x d	mm	870x665x235	870x665x235	1200x665x235	1200x665x235	1200x665x235
Dimension of panel	w x h x d	mm	-	-	-	-	-
Package dimension of ID	w x h x d	mm	1033x770x300	1033x770x300	1363x770x300	1363x770x300	1363x770x300
Package dimension of panel	w x h x d	mm	-	-	-	-	-
Weight of ID	netto / brutto	kg	25/30	26/31	31/37	31/37	32/38
Weight of panel	netto / brutto	kg	-	-	-	-	-
Set temperature range		°C	16-30	16-30	16-30	16-30	16-30
ADDITIONAL TECHNICAL INFORMATION							
Screw holes distance	w x d	mm	812x318	812x318	1142x318	1142x318	1142x318
Communication cable		mm ²	2x0,75	2x0,75	2x0,75	2x0,75	2x0,75
Recommended power cable		mm ²	3x1,5	3x1,5	3x1,5	3x1,5	3x1,5
Recommended air switch		A	6	6	6	6	6
EQUIPMENT							
Plasma generator			-	-	-	-	-
Wifi module					optional (SWM-03)		
Drain pump			-	-	-	-	-
Max. lift (from bottom of ID unit)		mm	-	-	-	-	-
Dry contact (ON/OFF)			✓	✓	✓	✓	✓
Alarm contact			-	-	-	-	-
Fresh air inlet			-	-	-	-	-
STANDARD ACCESSORIES							
Standard health filter			-	-	-	-	-
Remote controller (IR)			YAP1F6	YAP1F6	YAP1F6	YAP1F6	YAP1F6
Wired controller			XK117	XK117	XK117	XK117	XK117
OPTIONAL ACCESSORIES							
Optional health filters			-	-	-	-	-
Wired controller with weekly timer			SWC-03	SWC-03	SWC-03	SWC-03	SWC-03
Central controller			SCC-16, SCC-36	SCC-16, SCC-36	SCC-16, SCC-36	SCC-16, SCC-36	SCC-16, SCC-36
MODBUS gateway			SMG-01	SMG-01	SMG-01	SMG-01	SMG-01
Dry contact gateway			SDG-01	SDG-01	SDG-01	SDG-01	SDG-01

The specification of products is subject to change based on further development of the units by the producer and can be changed without prior notice. Refer to rating label.

R32 (single component refrigerant HFC), GWP of refrigerant used: 675.

Contains fluorinated greenhouse gases covered by the Kyoto Protocol.

Explanatory notes on the very last page of the catalogue.

It is necessary to combine with an appropriate outdoor unit from UNI SPLIT series (ASGE-xxBI, ASGE-xxBI-3).

FLOOR-CEILING INDOOR UNITS

UNI SPLIT SERIES

MODEL			ASF-36BI / ASGE-36BI-3	ASF-42BI / ASGE-42BI-3	ASF-48BI / ASGE-48BI-3	ASF-60BI / ASGE-60BI-3
Capacity cooling/heating 1)	Nominal	kW	10,0 (1,2-10,5) / 12,0 (2,5-12,4)	12,1 (1,6-12,7) / 13,5 (3,0-14,0)	13,4 (1,6-14,1) / 15,5 (3,4-16,0)	16,0 (2,0-16,8) / 17,0 (3,7-17,6)
Power supply		Hz / V	1~ / 50 / 220-240	1~ / 50 / 220-240	1~ / 50 / 220-240	1~ / 50 / 220-240
Energy class cooling 3)		-	A++	A++	A++	A++
Pdesign cooling		kW	10,0	-	-	-
SEER		-	6,1	6,1	6,1	6,1
Annual power consumption		kWh / annum	561	-	-	-
Energy class heating 3)	Average climate	-	A+	A	A+	A+
Pdesign heating	Average climate	kW	9,0	-	-	-
SCOP	Average climate	-	4,0	3,8	4,0	4,0
Annual power consumption	Average climate	kWh / annum	3146	-	-	-
Air flow of ID	H	m ³ / h	1600	1800	2100	2300
Sound pressure of ID at 1m 4)	SH/H/M/L	dB(A)	49/47/45/43	49/47/44/42	52/50/48/44	54/53/49/45
Sound power of ID 4)	H	dB(A)	61	61	65	67
External static pressure	nom/min-max	Pa	-	-	-	-
Dehumidifying volume		l / h	-	-	-	-
Refrigerant type	Type		R32	R32	R32	R32
Pipe diameter - liquid side 5)	inch / mm		3/8 / 9,5	3/8 / 9,5	3/8 / 9,5	3/8 / 9,5
Pipe diameter - gas side 5)	inch / mm		1/2 / 15,9	1/2 / 15,9	1/2 / 15,9	1/2 / 15,9
Dimension of ID	w x h x d	mm	1200x665x235	1570x665x235	1570x665x235	1570x665x235
Dimension of panel	w x h x d	mm	-	-	-	-
Package dimension of ID	w x h x d	mm	1363x770x300	1729x770x300	1729x770x300	1729x770x300
Package dimension of panel	w x h x d	mm	-	-	-	-
Weight of ID	netto / brutto	kg	32/38	40/47	42/49	42/49
Weight of panel	netto / brutto	kg	-	-	-	-
Set temperature range		°C	16-30	16-30	16-30	16-30
ADDITIONAL TECHNICAL INFORMATION						
Screw holes distance	w x d	mm	114x318	1512x318	1512x318	1512x318
Communication cable		mm ²	2x0,75	2x0,75	2x0,75	2x0,75
Recommended power cable		mm ²	3x1,5	3x1,5	3x1,5	3x1,5
Recommended air switch		A	6	6	6	6
EQUIPMENT						
Plasma generator			-	-	-	-
Wifi module				optional (SWM-03)		
Drain pump			-	-	-	-
Max. lift (from bottom of ID unit)		mm	-	-	-	-
Dry contact (ON/OFF)			✓	✓	✓	✓
Alarm contact			-	-	-	-
Fresh air inlet			-	-	-	-
STANDARD ACCESSORIES						
Standard health filter			-	-	-	-
Remote controller (IR)			YAP1F6	YAP1F6	YAP1F6	YAP1F6
Wired controller			XK117	XK117	XK117	XK117
OPTIONAL ACCESSORIES						
Optional health filters			-	-	-	-
Wired controller with weekly timer			SWC-03	SWC-03	SWC-03	SWC-03
Central controller			SCC-16, SCC-36	SCC-16, SCC-36	SCC-16, SCC-36	SCC-16, SCC-36
MODBUS gateway			SMG-01	SMG-01	SMG-01	SMG-01
Dry contact gateway			SDG-01	SDG-01	SDG-01	SDG-01

The specification of products is subject to change based on further development of the units by the producer and can be changed without prior notice. Refer to rating label.

R32 (single component refrigerant HFC), GWP of refrigerant used: 675.

Contains fluorinated greenhouse gases covered by the Kyoto Protocol.

Explanatory notes on the very last page of the catalogue.

It is necessary to combine with an appropriate outdoor unit from UNI SPLIT series (ASGE-xxBI, ASGE-xxBI-3).

APPEARANCE AND DIMENSIONS OF FLOOR-CEILING INDOOR UNITS

UNI SPLIT SERIES

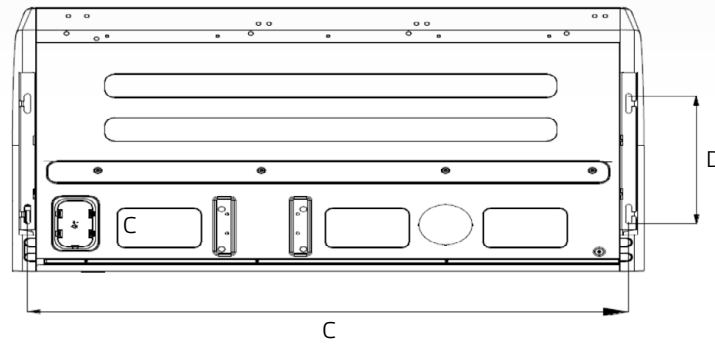
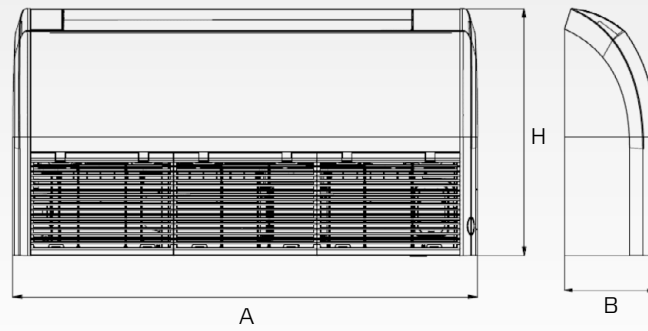

units: mm

	A	B	C	D	H
ASF-12BI	870	235	812	318	665
ASF-18BI	870	235	812	318	665
ASF-24BI	1200	235	1142	318	665
ASF-30BI	1200	235	1142	318	665
ASF-36BI	1200	235	1142	318	665
ASF-42BI	1570	235	1512	318	665
ASF-48BI	1570	235	1512	318	665
ASF-60BI	1570	235	1512	318	665

4-WAY CASSETTE INDOOR UNITS

UNI SPLIT SERIES

MODEL			ASC-12BI / ASGE-12BI	ASC-18BI / ASGE-18BI	ASC-24BI / ASGE-24BI	ASC-30BI / ASGE-30BI	ASC-36BI / ASGE-36BI
Capacity cooling/heating 1)	Nominal	kW	3,5 (0,4-3,7) / 4,0 (0,8-4,1)	5,0 (0,6-5,3) / 5,5 (1,2-5,7)	7,0 (0,8-7,3) / 8,0 (1,6-8,4)	8,5 (1,0-8,9) / 8,8 (2,0-9,1)	10,0 (1,2-10,6) / 12,0 (2,6-12,4)
Power supply		Hz / V	1~ / 50 / 220-240	1~ / 50 / 220-240	1~ / 50 / 220-240	1~ / 50 / 220-240	1~ / 50 / 220-240
Energy class cooling 3)		-	A+	A+	A++	A++	A++
Pdesign cooling		kW	3,5	5,0	7,0	8,5	10,0
SEER		-	5,9	5,9	7,2	6,1	6,1
Annual power consumption		kWh / annum	213	296	340	472	566
Energy class heating 3)	Average climate	-	A+	A+	A	A+	A+
Pdesign heating	Average climate	kW	3,1	4,0	6,4	7,2	9,0
SCOP	Average climate	-	4,0	4,0	3,9	4,0	4,0
Annual power consumption	Average climate	kWh / annum	1069	1405	2297	2616	3139
Air flow of ID	SH/H/M/L	m³ / h	650/580/480/400	700/580/480/400	1100/1050/960/870	1400/1310/1180/1040	1500/1470/1380/1220
Sound pressure of ID at 1,4m 4)	SH/H/M/L	dB(A)	39/36/33	44/39/36/33	43/42/40/39	49/47/44/41	50/48/46/42
Sound power of ID 4)	H	dB(A)	57	53	52	58	59
External static pressure	nom/min-max	Pa	-	-	-	-	-
Dehumidifying volume		l / h	-	-	-	-	-
Refrigerant type	Type		R32	R32	R32	R32	R32
Pipe diameter - liquid side 5)	inch / mm		¼ / 6,4	¼ / 6,4	¾ / 9,5	¾ / 9,5	¾ / 9,5
Pipe diameter - gas side 5)	inch / mm		¾ / 9,5	¾ / 12,7	¾ / 15,9	¾ / 15,9	¾ / 15,9
Dimension of ID	w x h x d	mm	570x265x570	570x265x570	840x240x840	840x240x840	840x240x840
Dimension of panel	w x h x d	mm	620x47,5x620	620x47,5x620	950x52x950	950x52x950	950x52x950
Package dimension of ID	w x h x d	mm	698x295x653	698x295x653	963x325x963	963x325x963	963x325x963
Package dimension of panel	w x h x d	mm	701x125x701	701x125x701	1033x112x1038	1033x112x1038	1033x112x1038
Weight of ID	netto / brutto	kg	17 / 22	17/22	29/36	29/36	31/38
Weight of panel	netto / brutto	kg	3,0/4,5	3,0/4,5	6,0/9,5	6,0/9,5	6,0/9,5
Set temperature range		°C	16-30	16-30	16-30	16-30	16-30
ADDITIONAL TECHNICAL INFORMATION							
Screw holes distance	w x d	mm	520x560	520x560	660x790	660x790	660x790
Communication cable		mm²	2 x 0,75	2x0,75	2x0,75	2x0,75	2x0,75
Recommended power cable		mm²	3 x 1,5	3x1,5	3x1,5	3x1,5	3x1,5
Recommended air switch		A	6	6	6	6	6
EQUIPMENT							
Plasma generator			-	-	-	-	-
Wifi module					optional (SWM-03)		
Drain pump			✓	✓	✓	✓	✓
Max. lift (from bottom of ID unit)		mm	1000	1000	1000	1000	1000
Dry contact (ON/OFF)			✓	✓	✓	✓	✓
Alarm contact			-	-	-	-	-
Fresh air inlet			✓	✓	✓	✓	✓
Decorative panel			✓	✓	✓	✓	✓
STANDARD ACCESSORIES							
Standard health filter			-	-	-	-	-
Remote controller (IR)			YAP1F6	YAP1F6	YAP1F6	YAP1F6	YAP1F6
Wired controller			XK117	XK117	XK117	XK117	XK117
OPTIONAL ACCESSORIES							
Optional health filters			-	-	-	-	-
Wired controller with weekly timer			SWC-03	SWC-03	SWC-03	SWC-03	SWC-03
Central controller			SCC-16, SCC-36	SCC-16, SCC-36	SCC-16, SCC-36	SCC-16, SCC-36	SCC-16, SCC-36
MODBUS gateway			SMG-01	SMG-01	SMG-01	SMG-01	SMG-01
Dry contact gateway			SDG-01	SDG-01	SDG-01	SDG-01	SDG-01

The specification of products is subject to change based on further development of the units by the producer and can be changed without prior notice. Refer to rating label.

R32 (single component refrigerant HFC), GWP of refrigerant used: 675.

Contains fluorinated greenhouse gases covered by the Kyoto Protocol.

Explanatory notes on the very last page of the catalogue.

It is necessary to combine with an appropriate outdoor unit from UNI SPLIT series (ASGE-xxBI, ASGE-xxBI-3).

4-WAY CASSETTE INDOOR UNITS

UNI SPLIT SERIES

MODEL			ASC-36BI / ASGE-36BI-3	ASC-42BI / ASGE-42BI-3	ASC-48BI / ASGE-48BI-3	ASC-60BI / ASGE-60BI-3	
Capacity cooling/heating 1)	Nominal	kW	10,0 (1,17-10,59) / 12,0 (2,61-12,42)	12,1 (1,5-12,7) / 13,5 (3,1-14,0)	13,4 (1,7-14,1) / 15,5 (3,2-16,0)	16,0 (2,0-15,2) / 17,0 (3,5-17,6)	
Power supply		Hz / V	1~ / 50 / 220-240	1~ / 50 / 220-240	1~ / 50 / 220-240	1~ / 50 / 220-240	
Energy class cooling 3)		-	A++	A++	A++	A++	
Pdesign cooling		kW	10,0	-	-	-	
SEER		-	6,1	6,1	6,1	6,1	
Annual power consumption		kWh / annum	533	-	-	-	
Energy class heating 3)	Average climate	-	A+	A	A+	A	
Pdesign heating	Average climate	kW	9,0	-	-	-	
SCOP	Average climate	-	4,0	3,8	4,0	3,8	
Annual power consumption	Average climate	kWh / annum	3168	-	-	-	
Air flow of ID	SH/H/M/L	m ³ / h	1500/1470/1380/1220	1800/1690/1470/1260	1900/1690/1480/1140	2000/1880/1620/1430	
Sound pressure of ID at 1,4m 4)	SH/H/M/L	dB(A)	50/48/46/42	51/49/46/42	52/51/48/45	54/52/50/48	
Sound power of ID 4)	H	dB(A)	59	60	61	63	
External static pressure	nom/min-max	Pa	-	-	-	-	
Dehumidifying volume		l / h	-	-	-	-	
Refrigerant type		Type	R32	R32	R32	R32	
Pipe diameter - liquid side 5)		inch / mm	3/8 / 9,5	3/8 / 9,5	3/8 / 9,5	3/8 / 9,5	
Pipe diameter - gas side 5)		inch / mm	1/2 / 15,9	1/2 / 15,9	1/2 / 15,9	1/2 / 15,9	
Dimension of ID	w x h x d	mm	840x240x840	840x290x840	840x290x840	840x290x840	
Dimension of panel	w x h x d	mm	950x52x950	950x52x950	950x52x950	950x52x950	
Package dimension of ID	w x h x d	mm	963x325x963	963x379x963	963x379x963	963x379x963	
Package dimension of panel	w x h x d	mm	1033x112x1038	1033x112x1038	1033x112x1038	1033x112x1038	
Weight of ID	netto / brutto	kg	31/38	33/41	36/44	36/44	
Weight of panel	netto / brutto	kg	6,0/9,5	6,0/9,5	6,0/9,5	6,0/9,5	
Set temperature range		°C	16-30	16-30	16-30	16-30	
ADDITIONAL TECHNICAL INFORMATION							
Screw holes distance	w x d	mm	660x790	660x790	660x790	660x790	
Communication cable		mm ²	2x0,75	2x0,75	2x0,75	2x0,75	
Recommended power cable		mm ²	3x1,5	3x1,5	3x1,5	3x1,5	
Recommended air switch		A	6	6	6	6	
EQUIPMENT							
Plasma generator			-	-	-	-	
Wifi module			optional (SWM-03)				
Drain pump			✓	✓	✓	✓	
Max. lift (from bottom of ID unit)		mm	1000	1000	1000	1000	
Dry contact (ON/OFF)			✓	✓	✓	✓	
Alarm contact			-	-	-	-	
Fresh air inlet			✓	✓	✓	✓	
Decorative panel			✓	✓	✓	✓	
STANDARD ACCESSORIES							
Standard health filter			-	-	-	-	
Remote controller (IR)			YAP1F6	YAP1F6	YAP1F6	YAP1F6	
Wired controller			XK117	XK117	XK117	XK117	
OPTIONAL ACCESSORIES							
Optional health filters			-	-	-	-	
Wired controller with weekly timer			SWC-03	SWC-03	SWC-03	SWC-03	
Central controller			SCC-16, SCC-36	SCC-16, SCC-36	SCC-16, SCC-36	SCC-16, SCC-36	
MODBUS gateway			SMG-01	SMG-01	SMG-01	SMG-01	
Dry contact gateway			SDG-01	SDG-01	SDG-01	SDG-01	

The specification of products is subject to change based on further development of the units by the producer and can be changed without prior notice. Refer to rating label.

R32 (single component refrigerant HFC), GWP of refrigerant used: 675.

Contains fluorinated greenhouse gases covered by the Kyoto Protocol.

Explanatory notes on the very last page of the catalogue.

It is necessary to combine with an appropriate outdoor unit from UNI SPLIT series (ASGE-xxBI, ASGE-xxBI-3).

APPEARANCE AND DIMENSIONS OF CASSETTE INDOOR UNITS

UNI SPLIT SERIES

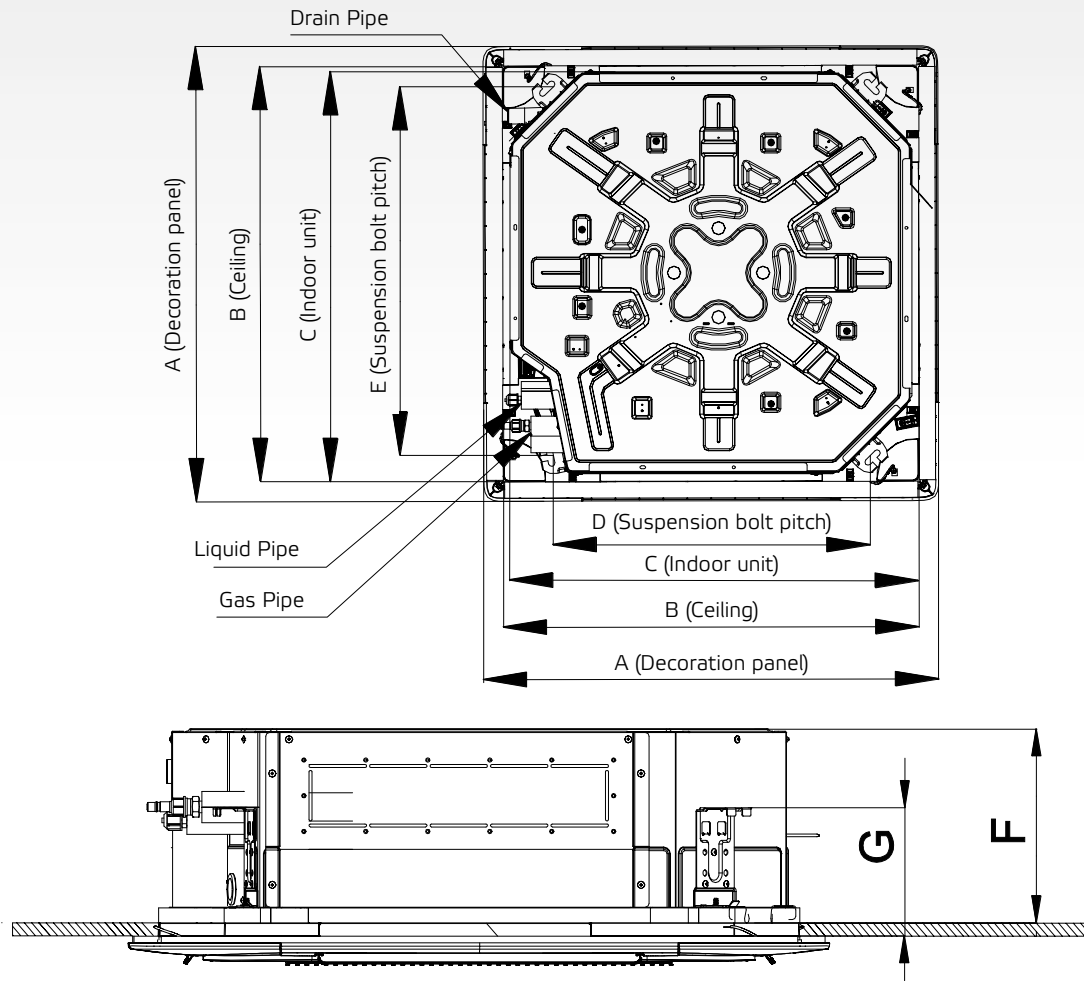

Dimensions Model	A	B	C	D	E	F	G
ASC-12BI	620	580	570	520	560	265	140
ASC-18BI	620	580	570	520	560	265	140
ASC-24BI	950	870	840	660	790	240	134
ASC-30BI	950	870	840	660	790	240	134
ASC-36BI	950	870	840	660	790	240	134
ASC-42BI	950	870	840	660	790	290	134
ASC-48BI	950	870	840	660	790	290	134
ASC-60BI	950	870	840	660	790	290	134

units: mm

DUCT INDOOR UNITS

UNI SPLIT SERIES

MODEL			ASD-12BI / ASGE-12BI	ASD-18BI / ASGE-18BI	ASD-24BI / ASGE-24BI	ASD-30BI / ASGE-30BI	ASD-36BI / ASGE-36BI
Capacity cooling/heating 1)	Nominal	kW	3,5 (0,7-3,7) / 4,0 (0,8-4,1)	5,0 (0,6-5,3) / 5,5 (1,1-5,7)	7,0 (0,8-7,6) / 8,0 (1,7-8,3)	8,5 (1,0-8,9) / 8,8 (2,0-9,1)	10,0 (1,2-10,6) / 12,0 (2,5-12,4)
Power supply		Hz / V	1~ / 50 / 220-240	1~ / 50 / 220-240	1~ / 50 / 220-240	1~ / 50 / 220-240	1~ / 50 / 220-240
Energy class cooling 3)		-	A++	A++	A++	A++	A++
Pdesign cooling		kW	3,5	5,0	7,0	8,5	10,0
SEER		-	6,1	6,1	6,8	6,1	6,1
Annual power consumption		kWh / annum	200	277	357	480	571
Energy class heating 3)	Average climate	-	A+	A+	A+	A+	A+
Pdesign heating	Average climate	kW	3,1	4,2	6,4	7,2	9,0
SCOP	Average climate	-	4,0	4,0	4,0	4,0	4,0
Annual power consumption	Average climate	kWh / annum	1110	1469	2238	2576	3147
Air flow of ID	H	m ³ / h	650	950	1200	1500	1800
Sound pressure of ID at 1,4m 4)	SH/H/M/L	dB(A)	41/38/36/34	43/42/39/36	40/39/37/36	42/40/37/35	46/44/42/40
Sound power of ID 4)	H	dB(A)	59	58	62	65	65
External static pressure	nom/min-max	Pa	25 (0-50)	25 (0-50)	25 (0-75)	37 (0-75)	37 (0-100)
Dehumidifying volume		l / h	-	-	-	-	-
Refrigerant type	Type		R32	R32	R32	R32	R32
Pipe diameter - liquid side 5)	inch / mm		¼ / 6,4	¼ / 6,4	¾ / 9,5	¾ / 9,5	¾ / 9,5
Pipe diameter - gas side 5)	inch / mm		¾ / 9,5	¾ / 12,7	¾ / 15,9	¾ / 15,9	¾ / 15,9
Dimension of ID	w x h x d	mm	700x200x450	1000x200x450	1300x220x450	1300x220x450	1000x300x700
Dimension of panel	w x h x d	mm	-	-	-	-	-
Package dimension of ID	w x h x d	mm	1008x275x568	1308x275x568	1570x283x545	1570x283x545	1205x360x813
Package dimension of panel	w x h x d	mm	-	-	-	-	-
Weight of ID	netto / brutto	kg	20/24	26/31	31/36	31/36	41/47
Weight of panel	netto / brutto	kg	-	-	-	-	-
Set temperature range		°C	16-30	16-30	16-30	16-30	16-30
ADDITIONAL TECHNICAL INFORMATION							
Screw holes distance	w x d	mm	760x415	1060x415	1360x415	1360x415	1040x500
Communication cable		mm ²	2x0,75	2x0,75	2x0,75	2x0,75	2x0,75
Recommended power cable		mm ²	3x1,5	3x1,5	3x1,5	3x1,5	3x1,5
Recommended air switch		A	6	6	6	6	6
EQUIPMENT							
Plasma generator			-	-	-	-	-
Wifi module					optional (SWM-03)		
Drain pump			✓	✓	✓	✓	✓
Max. lift (from bottom of ID unit)		mm	1000	1000	1000	1000	1000
Dry contact (ON/OFF)			✓	✓	✓	✓	✓
Alarm contact			-	-	-	-	-
Fresh air inlet			✓	✓	✓	✓	✓
STANDARD ACCESSORIES							
Standard health filter			-	-	-	-	-
Remote controller (IR)			YAP1F6	YAP1F6	YAP1F6	YAP1F6	YAP1F6
Wired controller			XK117	XK117	XK117	XK117	XK117
OPTIONAL ACCESSORIES							
Optional health filters			-	-	-	-	-
Wired controller with weekly timer			SWC-03	SWC-03	SWC-03	SWC-03	SWC-03
Central controller			SCC-16, SCC-36	SCC-16, SCC-36	SCC-16, SCC-36	SCC-16, SCC-36	SCC-16, SCC-36
MODBUS gateway			SMG-01	SMG-01	SMG-01	SMG-01	SMG-01
Dry contact gateway			SDG-01	SDG-01	SDG-01	SDG-01	SDG-01

The specification of products is subject to change based on further development of the units by the producer and can be changed without prior notice. Refer to rating label.

R32 (single component refrigerant HFC), GWP of refrigerant used: 675.

Contains fluorinated greenhouse gases covered by the Kyoto Protocol.

Explanatory notes on the very last page of the catalogue.

It is necessary to combine with an appropriate outdoor unit from UNI SPLIT series (ASGE-xxBI, ASGE-xxBI-3).

DUCT INDOOR UNITS

UNI SPLIT SERIES

MODEL			ASD-36BI / ASGE-36BI-3	ASD-42BI / ASGE-42BI-3	ASD-48BI / ASGE-48BI-3	ASD-60BI / ASGE-60BI-3	
Capacity cooling/heating 1)	Nominal	kW	10,0 (1,2-10,6) / 12,0 (2,5-12,4)	12,1 (1,6-12,7) / 13,5 (3,0-14,0)	13,4 (1,6-14,1) / 15,5 (3,4-16,0)	16,0 (2,0-16,8) / 17,0 (3,7-17,6)	
Power supply		Hz / V	1~ / 50 / 220-240	1~ / 50 / 220-240	1~ / 50 / 220-240	1~ / 50 / 220-240	
Energy class cooling 3)		-	A++	A+	A+	A++	
Pdesign cooling		kW	10,0	-	-	-	
SEER		-	6,1	5,8	5,4	6,1	
Annual power consumption		kWh / annum	577	-	-	-	
Energy class heating 3)	Average climate	-	A+	A	A	A+	
Pdesign heating	Average climate	kW	9,0	-	-	-	
SCOP	Average climate	-	4,0	3,8	3,7	4,0	
Annual power consumption	Average climate	kWh / annum	3218	-	-	-	
Air flow of ID	H	m ³ / h	1800	2000	2200	2400	
Sound pressure of ID at 1,4m 4)	SH/H/M/L	dB(A)	46/44/42/40	42/40/39/37	43/41/40/38	44/41/39/38	
Sound power of ID 4)	H	dB(A)	65	66	65	66	
External static pressure	nom/min-max	Pa	37 (0-100)	50 (0-150)	50 (0-150)	50 (0-200)	
Dehumidifying volume		l / h	-	-	-	-	
Refrigerant type		Type	R32	R32	R32	R32	
Pipe diameter - liquid side 5)		inch / mm	3/8 / 9,5	3/8 / 9,5	3/8 / 9,5	3/8 / 9,5	
Pipe diameter - gas side 5)		inch / mm	1/2 / 15,9	1/2 / 15,9	1/2 / 15,9	1/2 / 15,9	
Dimension of ID	w x h x d	mm	1000x300x700	1400x300x700	1400x300x700	1400x300x700	
Dimension of panel	w x h x d	mm	-	-	-	-	
Package dimension of ID	w x h x d	mm	1205x360x813	1601x365x813	1601x365x813	1678x365x808	
Package dimension of panel	w x h x d	mm	-	-	-	-	
Weight of ID	netto / brutto	kg	41/47	50/56	50/56	57/64	
Weight of panel	netto / brutto	kg	-	-	-	-	
Set temperature range		°C	16-30	16-30	16-30	16-30	
ADDITIONAL TECHNICAL INFORMATION							
Screw holes distance	w x d	mm	1040x500	1440x500	1440x500	1440x500	
Communication cable		mm ²	2x0,75	2x0,75	2x0,75	2x0,75	
Recommended power cable		mm ²	3x1,5	3x1,5	3x1,5	3x1,5	
Recommended air switch		A	6	6	6	6	
EQUIPMENT							
Plasma generator			-	-	-	-	
Wifi module			optional (SWM-03)				
Drain pump			✓	✓	✓	✓	
Max. lift (from bottom of ID unit)		mm	1000	1000	1000	1000	
Dry contact (ON/OFF)			✓	✓	✓	✓	
Alarm contact			-	-	-	-	
Fresh air inlet			✓	✓	✓	✓	
STANDARD ACCESSORIES							
Standard health filter			-	-	-	-	
Remote controller (IR)			YAP1F6	YAP1F6	YAP1F6	YAP1F6	
Wired controller			XK117	XK117	XK117	XK117	
OPTIONAL ACCESSORIES							
Optional health filters			-	-	-	-	
Wired controller with weekly timer			SWC-03	SWC-03	SWC-03	SWC-03	
Central controller			SCC-16, SCC-36	SCC-16, SCC-36	SCC-16, SCC-36	SCC-16, SCC-36	
MODBUS gateway			SMG-01	SMG-01	SMG-01	SMG-01	
Dry contact gateway			SDG-01	SDG-01	SDG-01	SDG-01	

The specification of products is subject to change based on further development of the units by the producer and can be changed without prior notice. Refer to rating label.

R32 (single component refrigerant HFC), GWP of refrigerant used: 675.

Contains fluorinated greenhouse gases covered by the Kyoto Protocol.

Explanatory notes on the very last page of the catalogue.

It is necessary to combine with an appropriate outdoor unit from UNI SPLIT series (ASGE-xxBI, ASGE-xxBI-3).

APPEARANCE AND DIMENSIONS OF DUCT INDOOR UNITS

UNI SPLIT SERIES

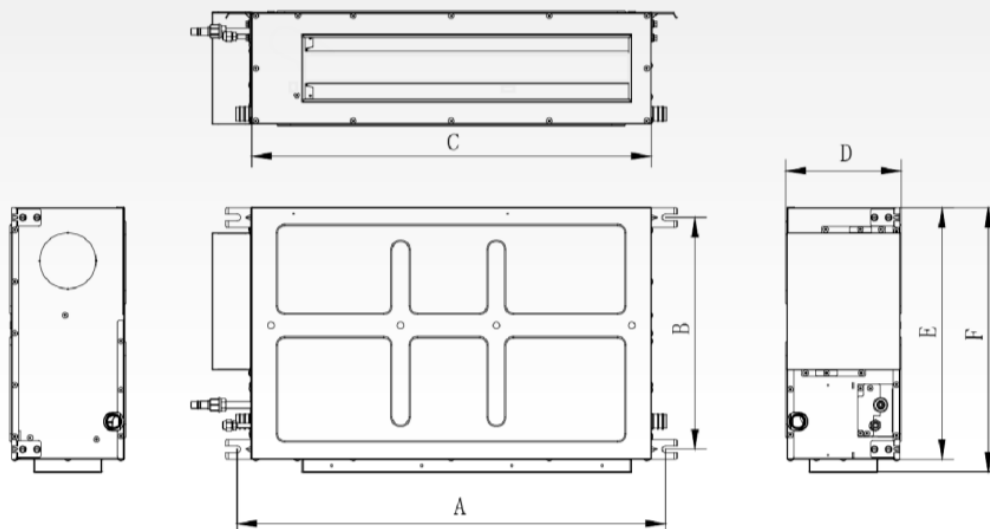

Dimensions Model	A	B	C	D	E	F
ASD-12BI	760	415	700	200	450	474
ASD-18BI	1060	415	1000	200	450	474
ASD-24BI	1360	415	1300	220	450	474
ASD-30BI						
ASD-36BI	1040	500	1000	300	700	754
ASD-42BI	1440	500	1400	300	700	754
ASD-48BI						
ASD-60BI						

DIMENSIONS OF AIR INLET AND OUTLET

UNI SPLIT SERIES

Air outlet

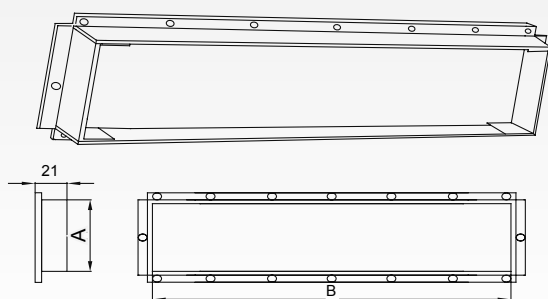

Air inlet

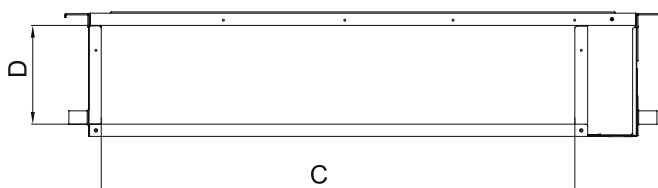

Dimensions	Air outlet		Air inlet	
	A	B	C	D
ASD-12BI	122	585	700	200
ASD-18BI	122	885	1000	200
ASD-24BI	142	1185	1300	220
ASD-30BI				
ASD-36BI	195	746	960	264
ASD-42BI	195	1150	1360	264
ASD-48BI				
ASD-60BI				

OUTDOOR UNITS

UNI SPLIT SERIES

MODEL			ASGE-12BI	ASGE-18BI	ASGE-24BI	ASGE-30BI	ASGE-36BI
Capacity cooling/heating 1)	Nominal (min-max)	kW	3,5/4,0	5,0/5,5	7,0/8,0	8,5/8,8	10,0/12,0
Power supply		Hz / V	1~ / 50 / 220-240	1~ / 50 / 220-240	1~ / 50 / 220-240	1~ / 50 / 220-240	1~ / 50 / 220-240
Power input cooling/heating 1)		W	950/1050	1550/1450	2100/2450	2800/2650	3300/3600
Maximal power input 2)		W	1350	1750	3500	3950	4050
Power current cooling/heating		A	4,18/4,70	6,50/6,90	8,80/10,50	12,7/11,7	14,5/15,9
Maximal power current 2)		A	6,0	8,0	16,0	18,0	18,5
Air flow of ID	H	m ³ / h	3000	3000	3600	4000	5900
Sound pressure of ID at 1m 4)	H	dB(A)	50	50	52	53	55
Sound power of ID 4)	H	dB(A)	64	65	67	69	70
Refrigerant type/charge		Type / kg / t eq. CO ₂	R32/0,78/0,53	R32/1,00/0,68	R32/1,60/1,08	R32/1,80/1,22	R32/2,50/1,69
Additional refrigerant		g / m	16	16	40	40	40
Pipe diameter - liquid side 5)		inch / mm	¼ / 6,4	¼ / 6,4	¾ / 9,5	¾ / 9,5	¾ / 9,5
Pipe diameter - gas side 5)		inch / mm	¾ / 9,5	¾ / 12,7	¾ / 15,9	¾ / 15,9	¾ / 15,9
Max pipe length without additional refrigerant 6)		m	5	5	5	5	5
Allowed pipe length 7)	min/max	m	3 / 30	3 / 35	3 / 50	3 / 50	3 / 65
Max. elevation/ Drop height		m	15	20	25	25	30
Dimension of ID	w x h x d	mm	818x596x378	818x596x378	892x698x396	920x790x427	940x820x530
Package dimension of ID	w x h x d	mm	948x645x420	948x645x420	1029x750x458	1083x855x488	1073x868x563
Weight of ID	netto / brutto	kg	37/40	39/42	53/57	60/65	83/95
Operating temperature range cooling 8)		°C	-20~48	-20~48	-20~48	-20~48	-20~48
Operating temperature range heating 8)		°C	-20~24	-20~24	-20~24	-20~24	-20~24
ADDITIONAL TECHNICAL INFORMATION							
Screw holes distance of OD	w x d	mm	550x348	550x348	560x364	610x395	610x486
Communication cable		mm ²	2x0,75	2x0,75	2x0,75	2x0,75	2x0,75
Recommended power cable		mm ²	3x1,5	3x2,5	3x2,5	3x4,0	3x4,0
Recommended air switch		A	13	16	16	20	25
EQUIPMENT							
Throttling method			EXV	EXV	EXV	EXV	EXV
Bottom chassis heater			-	-	-	-	-
Crankcase heater				Preheating			Heating belt
Bottom plugs for OD			✓	✓	✓	✓	✓
Drain pipe connector			✓	✓	✓	✓	✓
OPTIONAL ACCESSORIES							
Communication module			SCMI-01.4, SCMI-01.4X	SCMI-01.4, SCMI-01.4X	SCMI-01.4, SCMI-01.4X	SCMI-01.4, SCMI-01.4X	SCMI-01.4, SCMI-01.4X

The specification of products is subject to change based on further development of the units by the producer and can be changed without prior notice. Refer to rating label.

R32 (single component refrigerant HFC), GWP of refrigerant used: 675.

Contains fluorinated greenhouse gases covered by the Kyoto Protocol.

Explanatory notes on the very last page of the catalogue.

It is necessary to combine with an appropriate indoor unit from UNI SPLIT series (ASC-xxBI, ASD-xxBI, ASF-xxBI).

OUTDOOR UNITS

UNI SPLIT SERIES

MODEL			ASGE-36BI-3	ASGE-42BI-3	ASGE-48BI-3	ASGE-60BI-3
Capacity cooling/heating 1)	Nominal (min-max)	kW	10,0/12,0	12,1/13,5	13,4/15,5	16,0/17,0
Power supply		Hz / V	3~ / 50 / 380-415	3~ / 50 / 380-415	3~ / 50 / 380-415	3~ / 50 / 380-415
Power input cooling/heating 1)		W	3300/3500	4050/4150	4700/4450	5450/5400
Maximal power input 2)		W	4650	5300	5950	5950
Power current cooling/heating		A	5,1/5,6	5,9/6,1	7,2/6,7	7,7/7,6
Maximal power current 2)		A	7	8	9	9
Air flow of ID	H	m ³ / h	5900	5900	5900	6600
Sound pressure of ID at 1m 4)	H	dB(A)	55	56	57	57
Sound power of ID 4)	H	dB(A)	70	71	72	72
Refrigerant type/charge		Type / kg / t eq. CO ₂	R32/2,5/1,69	R32/2,65/1,79	R32/2,8/1,89	R32/3,6/2,43
Additional refrigerant		g / m	40	40	40	40
Pipe diameter - liquid side 5)		inch / mm	¾ / 9,5	¾ / 9,5	¾ / 9,5	¾ / 9,5
Pipe diameter - gas side 5)		inch / mm	¾ / 15,9	¾ / 15,9	¾ / 15,9	¾ / 15,9
Max pipe length without additional refrigerant 6)		m	5	5	7,5	7,5
Allowed pipe length 7)	min/max	m	3 / 65	3 / 75	3 / 75	3 / 75
Max. elevation/ Drop height		m	30	30	30	30
Dimension of ID	w x h x d	mm	940x820x530	940x820x530	940x820x530	900x1345x412
Package dimension of ID	w x h x d	mm	1073x868x563	1073x868x563	1073x868x563	1033x1395x443
Weight of ID	netto / brutto	kg	89/101	95/107	99/111	112/122
Operating temperature range cooling 8)		°C	-20~48	-20~48	-20~48	-20~48
Operating temperature range heating 8)		°C	-20~24	-20~24	-20~24	-20~24
ADDITIONAL TECHNICAL INFORMATION						
Screw holes distance of OD	w x d	mm	610x486	610x486	610x486	572x378
Communication cable		mm ²	2x0,75	2x0,75	2x0,75	2x0,75
Recommended power cable		mm ²	5x2,5	5x2,5	5x2,5	5x2,5
Recommended air switch		A	16	16	16	16
EQUIPMENT						
Throttling method			EXV	EXV	EXV	EXV
Bottom chassis heater			-	-	-	-
Crankcase heater				Heating belt		
Bottom plugs for OD			✓	✓	✓	✓
Drain pipe connector			✓	✓	✓	✓
OPTIONAL ACCESSORIES						
Communication module			SCMI-01.4, SCMI-01.4X	SCMI-01.4, SCMI-01.4X	SCMI-01.4, SCMI-01.4X	SCMI-01.4, SCMI-01.4X

The specification of products is subject to change based on further development of the units by the producer and can be changed without prior notice. Refer to rating label.

R32 (single component refrigerant HFC), GWP of refrigerant used: 675.

Contains fluorinated greenhouse gases covered by the Kyoto Protocol.

Explanatory notes on the very last page of the catalogue.

It is necessary to combine with an appropriate indoor unit from UNI SPLIT series (ASC-xxBI, ASD-xxBI, ASF-xxBI).

APPEARANCE AND DIMENSIONS OF OUTDOOR UNIT

UNI SPLIT SERIES

ASGE-12BI, ASGE-18BI, ASGE-24BI, ASGE-30BI

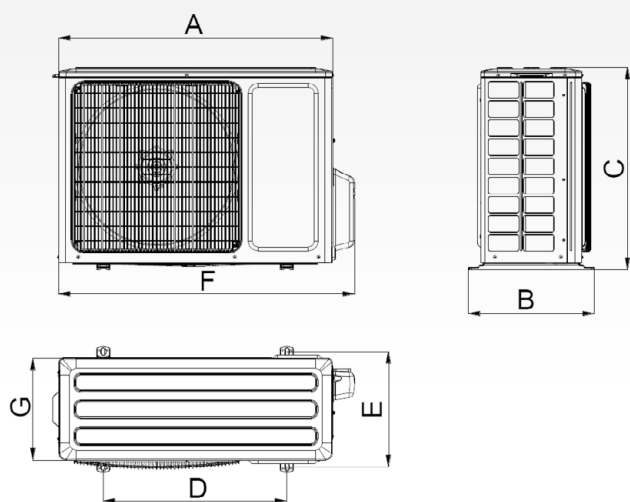

ASGE-36BI, ASGE-36BI-3, ASGE-42BI-3, ASGE-48BI-3

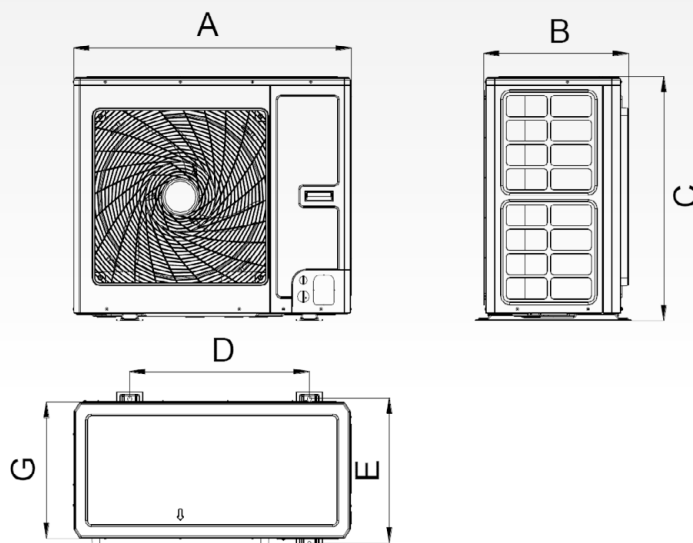

ASGE-60BI-3

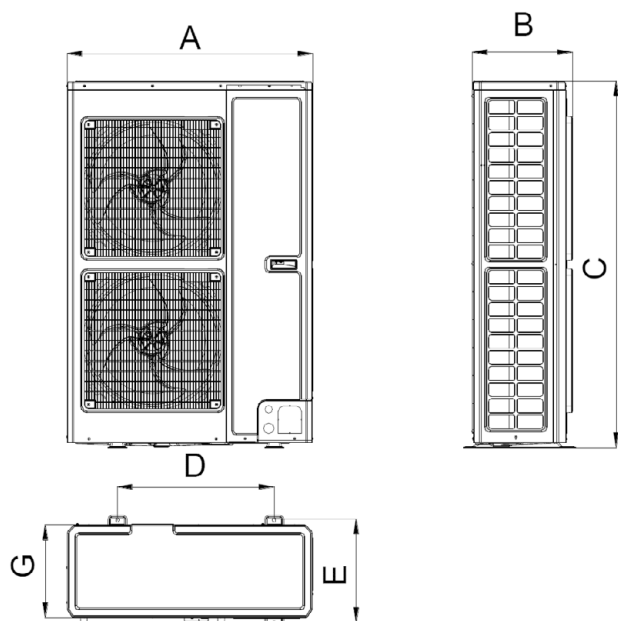

Dimensions Model	A	B	C	D	E	F	G
ASGE-12BI	818	378	596	550	348	887	302
ASGE-18BI	818	378	596	550	348	887	302
ASGE-24BI	892	396	698	560	364	952	340
ASGE-30BI	920	427	790	610	395	1002	370
ASGE-36BI	940	530	820	610	486	/	460
ASGE-36BI-3	940	530	820	610	486	/	460
ASGE-42BI-3	940	530	820	610	486	/	460
ASGE-48BI-3	940	530	820	610	486	/	460
ASGE-60BI-3	900	412	1345	572	378	/	340

units: mm

ELECTRICAL WIRING DIAGRAM

UNI SPLIT SERIES

ASGE-12BI, ASGE-18BI, ASGE-24BI, ASGE-30BI

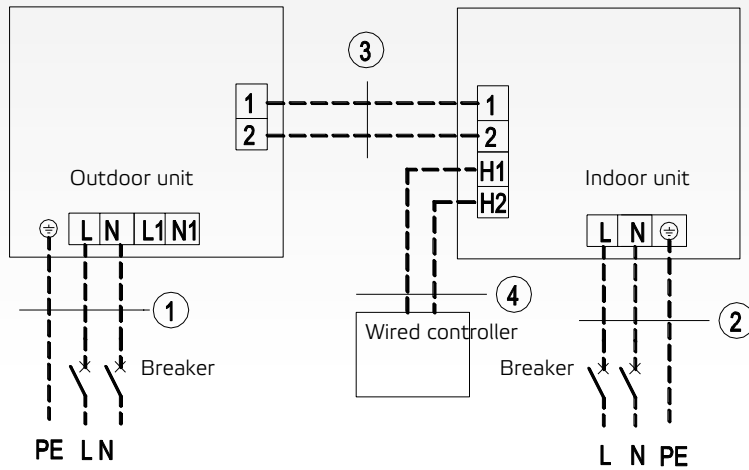

Power : 220–240 V~, 50 Hz / 208–230 V~, 60 Hz

Power : 220–240 V~, 50 Hz / 208–230 V~, 60 Hz

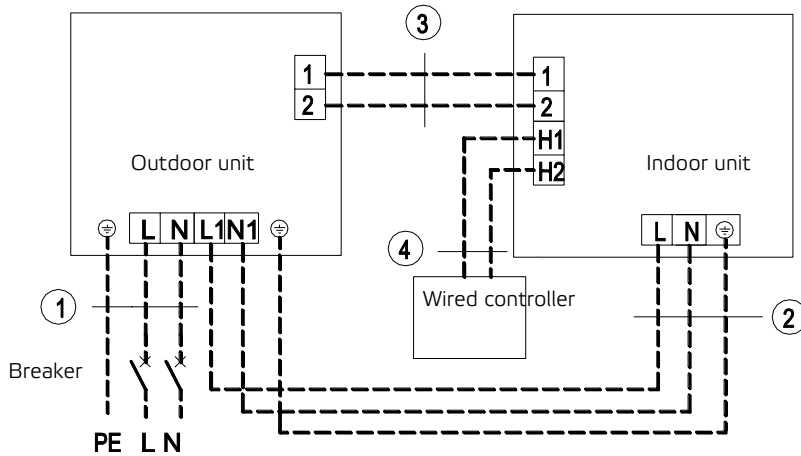

Power : 220–240 V~, 50 Hz / 208–230 V~, 60 Hz

Power : 220–240 V~, 50 Hz / 208–230 V~, 60 Hz

1 Outdoor unit power supply **2** Indoor unit power supply **3** Communication cable **4** Communication cable

ELECTRICAL WIRING DIAGRAM

UNI SPLIT SERIES

ASGE-36BI

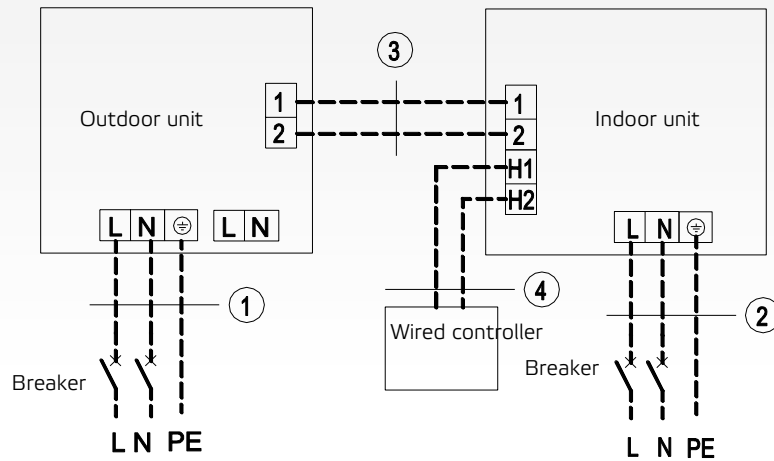

Power : 220–240 V~, 50 Hz / 208–230 V~, 60 Hz

Power : 220–240 V~, 50 Hz / 208–230 V~, 60 Hz

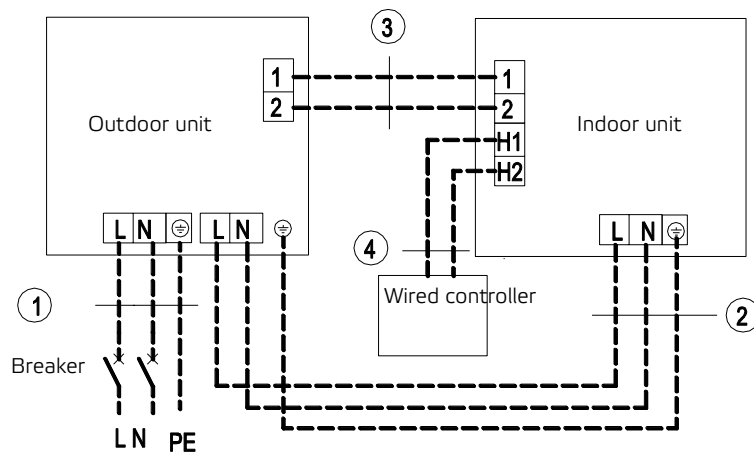

Power : 220–240 V~, 50 Hz / 208–230 V~, 60 Hz

Power : 220–240 V~, 50 Hz / 208–230 V~, 60 Hz

1 Outdoor unit power supply **2** Indoor unit power supply **3** Communication cable **4** Communication cable

ELECTRICAL WIRING DIAGRAM

UNI SPLIT SERIES

ASGE-36BI-3, ASGE-42BI-3, ASGE-48BI-3, ASGE-60BI-3

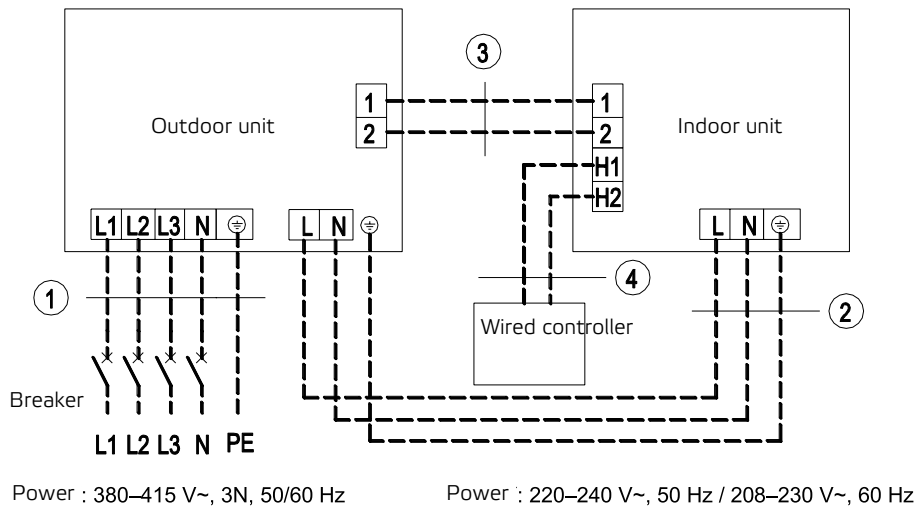
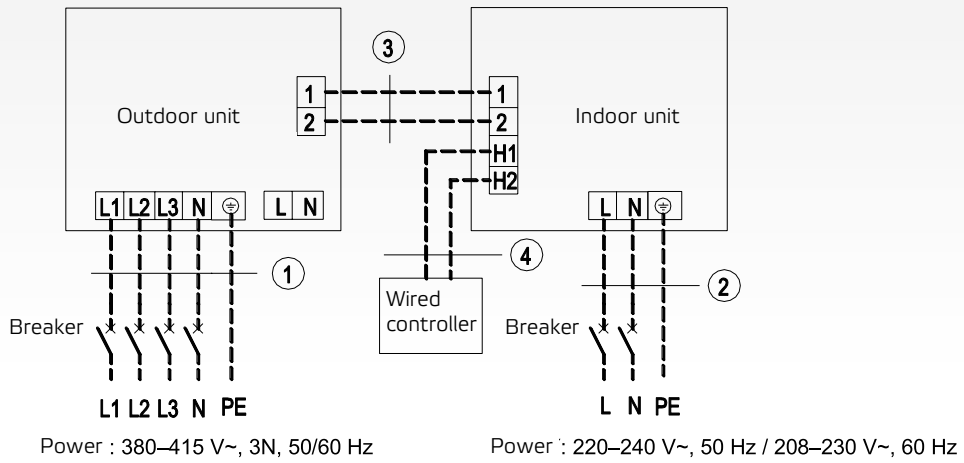

1 Outdoor unit power supply 2 Indoor unit power supply 3 Communication cable 4 Communication cable

WALL MOUNTED INDOOR UNITS FOCUS

MULTI VARIABLE SERIES

MODEL			MV-H07BIF	MV-H09BIF	MV-H12BIF	MV-H18BIF	MV-H24BIF	
Capacity cooling/heating 1)	Nominal	kW	2,1/2,6	2,6/2,8	3,5/3,6	5,1/5,2	6,4/6,4	
Power supply		Hz / V	1~ / 50 / 220-240	1~ / 50 / 220-240	1~ / 50 / 220-240	1~ / 50 / 220-240	1~ / 50 / 220-240	
Air flow of ID	SH/H/M/L	m ³ / h	560 / 490 / 430 / 330	560/490/430/330	680/590/490/420	800/720/610/520	1250/1050/950/850	
Sound pressure level of ID at 1m 4)	SH/H/M/L	dB(A)	39/36/32/28	41/37/35/32/29/26/24	42/38/35/32/30/28/26	45/43/41/38/35/34/31	48/45/42/39/37/36/33	
Sound power of ID 4)	SH/H/M/L	dB(A)	55/52/44/38	55/52/44/38	56/52/48/45	59/54/49/44	63/59/56/53	
External static pressure	nom/min-max	Pa	-	-	-	-	-	
Dehumidifying volume		l / h	0,6	0,8	1,4	1,8	2,0	
Refrigerant type		Type	R32	R32	R32	R32	R32	
Pipe diameter - liquid side 5)		inch / mm	¼ / 6,0	¼ / 6,0	¼ / 6,0	¼ / 6,0	¼ / 6,0	
Pipe diameter - gas side 5)		inch / mm	¾ / 9,5	¾ / 9,5	¾ / 9,5	¾ / 12,0	¾ / 16,0	
Dimension of ID	w x h x d	mm	790x275x200	790x275x200	845x289x209	970x300x224	1078x325x246	
Dimension of panel	w x h x d	mm	-	-	-	-	-	
Package dimension of ID	w x h x d	mm	866x271x367	866x271x367	921x281x379	1041x383x320	1148x413x350	
Package dimension of panel	w x h x d	mm	-	-	-	-	-	
Weight of ID	netto / brutto	kg	9/11	9/11	10,5/12,5	13,5/16,5	16,5/20	
Weight of panel	netto / brutto	kg	-	-	-	-	-	
Set temperature range		°C	16 ~ 30	16 ~ 30	16 ~ 30	16 ~ 30	16 ~ 30	
ADDITIONAL TECHNICAL INFORMATION								
Screw holes distance	w x d	mm	See service manual					
Communication cable		mm ²	4x1,0	4x1,0	4x1,0	4x1,0	4x1,5	
Recommended power cable 11)		mm ²	Outdoor unit power supplied					
Recommended air switch		A	Outdoor unit power supplied					
EQUIPMENT								
Plasma generator			✓	✓	✓	✓	✓	
Wifi module			✓	✓	✓	✓	✓	
Drain pump			-	-	-	-	-	
Max. lift (from bottom of ID unit)		mm	-	-	-	-	-	
Dry contact (ON/OFF)			✓	✓	✓	✓	✓	
Alarm contact			-	-	-	-	-	
Fresh air inlet			-	-	-	-	-	
STANDARD ACCESSORIES								
Standard health filter			SAF-OPWC4, SAF-OPWA4					
Remote controller (IR)			YAC1FB7	YAC1FB9	YAC1FB9	YAC1FB9	YAC1FB9	
Wired controller			-	-	-	-	-	
OPTIONAL ACCESSORIES								
Optional health filters			SAF-OPWB4, SAF-OPWK4, SAF-OPWM4, SAF-OPWP4, SAF-OPWS4					
Wired controller			SWC-02, XK19	SWC-02, XK19	SWC-02, XK19	SWC-02, XK19	SWC-02, XK19	
Central controller			SCC-16, SCC-36	SCC-16, SCC-36	SCC-16, SCC-36	SCC-16, SCC-36	SCC-16, SCC-36	
Other			G2S, G2S-T	G2S, G2S-T	G2S, G2S-T	G2S, G2S-T	G2S, G2S-T	

The specification of products is subject to change based on further development of the units by the producer and can be changed without prior notice. Refer to rating label.

R32 (single component refrigerant HFC), GWP of refrigerant used: 675.

Contains fluorinated greenhouse gases covered by the Kyoto Protocol.

Explanatory notes on the very last page of the catalogue.

These indoor units may be combined with other indoor units from MULTI VARIABLE series, it is essential to follow combinations recommended in the combination table.

APPEARANCE AND DIMENSIONS OF WALL MOUNTED INDOOR UNITS FOCUS
MULTI VARIABLE SERIES

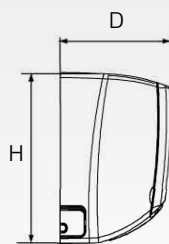
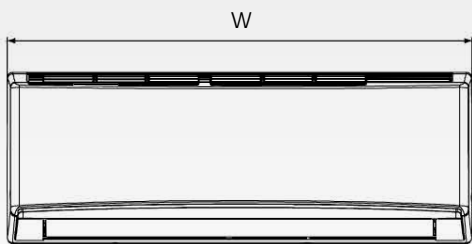

MV-H07BIF, MV-H09BIF

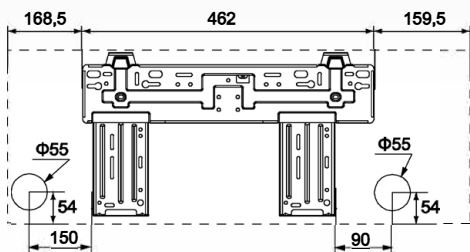

MV-H12BIF

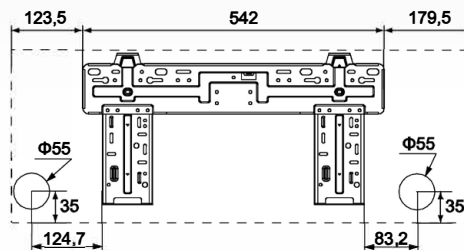

MV-H18BIF

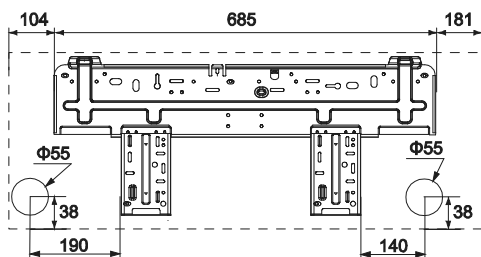

MV-H24BIF

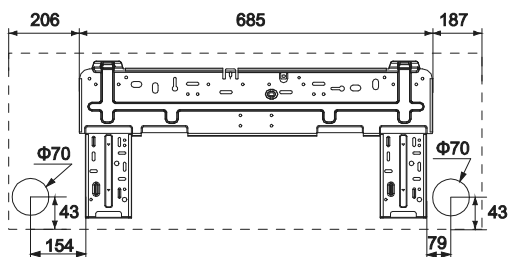

units: mm

MULTI VARIABLE SERIES

MODEL			MV-H09BIS/W MV-H09BIS/B	MV-H13BIS/W MV-H13BIS/B	MV-H18BIS/W MV-H18BIS/B	MV-H24BIS/W MV-H24BIS/B	
Capacity cooling/heating 1)	Nominal	kW	2,7 (0,9-3,8) / 3,0 (0,7-4,4)	3,5 (1,0-3,8) / 3,8 (1,2-4,4)	5,3 (1,3-6,6) / 5,6 (1,2-6,8)	7,0 (1,1-9,1) / 7,2 (1,7-10,1)	
Power supply		Hz / V	1~ / 50 / 220-240	1~ / 50 / 220-240	1~ / 50 / 220-240	1~ / 50 / 220-240	
Air flow of ID	SH/MH/H/ML/ML/SL	m ³ / h	660/590/540/490/450/420/390	680/590/540/490/450/420/390	850/750/610/520	1250/1100/1000/950/900/850/750	
Sound pressure level of ID at 1m 4)	SH/MH/H/ML/ML/SL	dB(A)	41/39/37/35/33/31/24	43/39/37/35/34/32/25	49/45/43/41/39/37/34	49/47/44/42/40/38/36	
Sound power of ID 4)	SH/MH/H/ML/ML/SL	dB(A)	56/53/52/50/48/46/39	58/53/52/50/48/46/40	58/55/53/51/49/47/44	65/61/58/56/54/52/50	
External static pressure	nom/min-max	Pa	-	-	-	-	
Dehumidifying volume		l / h	0,8	1,4	1,8	2,4	
Refrigerant type		Type	R32	R32	R32	R32	
Pipe diameter - liquid side 5)		inch / mm	¼ / 6,0	¼ / 6,0	¼ / 6,0	¼ / 6,0	
Pipe diameter - gas side 5)		inch / mm	¾ / 9,5	¾ / 9,5	¾ / 12,0	¾ / 16,0	
Dimension of ID	w x h x d	mm	865x290x210	865x290x210	996x301x225	1101x327x249	
Dimension of panel	w x h x d	mm	-	-	-	-	
Package dimension of ID	w x h x d	mm	931x281x379	931x281x379	1060x380x322	1167x405x354	
Package dimension of panel	w x h x d	mm	-	-	-	-	
Weight of ID	netto / brutto	kg	10,5 / 12,5	11,0 / 13,0	13,5 / 16,5	16,5 / 20	
Weight of panel	netto / brutto	kg	-	-	-	-	
Set temperature range		°C	16 ~ 30	16 ~ 30	16 ~ 30	16 ~ 30	
ADDITIONAL TECHNICAL INFORMATION							
Screw holes distance	w x d	mm	See service manual				
Communication cable		mm ²	4x1,0	4x1,0	4x1,0	4x1,0	
Recommended power cable 11)		mm ²	Outdoor unit power supplied				
Recommended air switch		A	Outdoor unit power supplied				
EQUIPMENT							
Plasma generator			✓	✓	✓	✓	
Wifi module			✓	✓	✓	✓	
Drain pump			-	-	-	-	
Max. lift (from bottom of ID unit)		mm	-	-	-	-	
Dry contact (ON/OFF)			✓	✓	✓	✓	
Alarm contact			-	-	-	-	
Fresh air inlet			-	-	-	-	
STANDARD ACCESSORIES							
Standard health filter			SAF-OPWC4, SAF-OPWA4				
Remote controller (IR)			YAG1FB2	YAG1FB2	YAG1FB2	YAG1FB2	
Wired controller			-	-	-	-	
OPTIONAL ACCESSORIES							
Optional health filters			SAF-OPWB4, SAF-OPWK4, SAF-OPWM4, SAF-OPWP4, SAF-OPWS4				
Wired controller			SWC-02, XK19				
Central controller			SCC-16, SCC-36				
Other			G25, G25-T				

The specification of products is subject to change based on further development of the units by the producer and can be changed without prior notice. Refer to rating label.

R32 (single component refrigerant HFC), GWP of refrigerant used: 675.

Contains fluorinated greenhouse gases covered by the Kyoto Protocol.

Explanatory notes on the very last page of the catalogue.

These indoor units may be combined with other indoor units from MULTI VARIABLE series, it is essential to follow combinations recommended in the combination table.

APPEARANCE AND DIMENSIONS OF WALL MOUNTED INDOOR UNITS SPECTRUM

MULTI VARIABLE SERIES

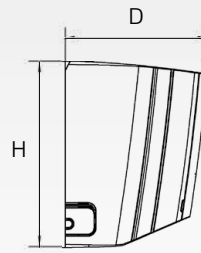
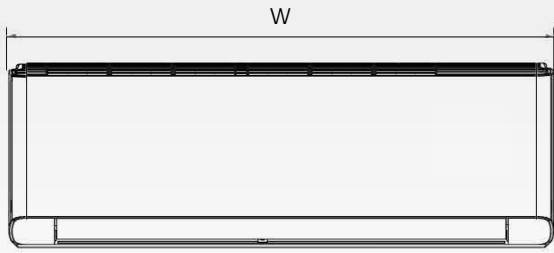

MV-H09BIS/W, MV-H09BIS/B, MV-H13BIS/W, MV-H13BIS/B

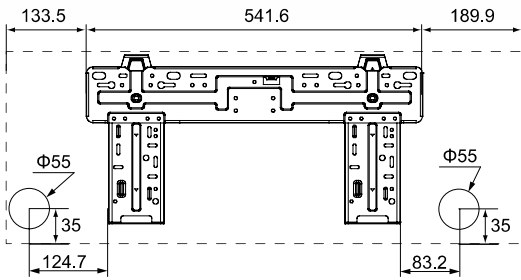

MV-H18BIS/W, MV-H18BIS/B

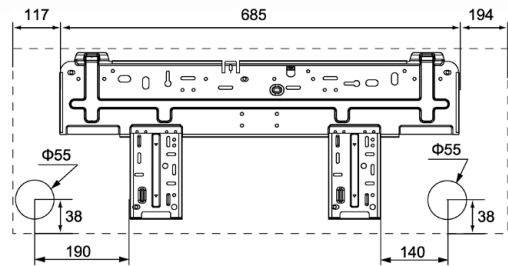

MV-H24BIS/W, MV-H24BIS/B

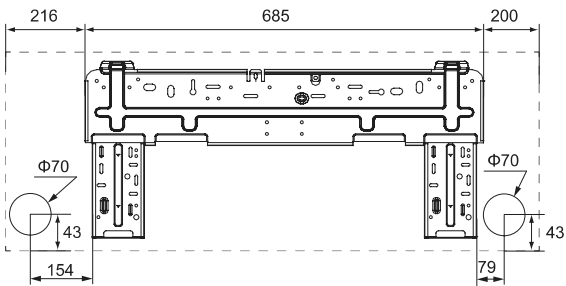

units: mm

CONSOLE INDOOR UNITS

MULTI VARIABLE SERIES

MODEL			MV-P09BI	MV-P12BI	MV-P18BI		
Capacity cooling/heating 1)	Nominal	kW	2,7/2,8	3,5/3,75	5,2/5,33		
Power supply		Hz / V	1~ / 50 / 220-240	1~ / 50 / 220-240	1~ / 50 / 220-240		
Air flow of ID	SH/MH/H/ML/ML/SL	m ³ / h	500/430/410/370/330/280/250	600/520/480/440/400/360/280	700/650/580/520/460/410/320		
Sound pressure level of ID at 1m 4)	SH/MH/H/ML/ML/SL	dB(A)	40/36/34/32/30/26/23	42/40/38/36/34/31/25	47/45/42/40/37/35/31		
Sound power of ID 4)	SH/MH/H/ML/ML/SL	dB(A)	52/48/46/44/42/38/34	52/50/48/46/44/41/35	57/55/52/50/47/45/41		
External static pressure	nom/min-max	Pa	-	-	-		
Dehumidifying volume		l / h	0,8	1,2	3,8		
Refrigerant type		Type	R32	R32	R32		
Pipe diameter - liquid side 5)		inch / mm	¼ / 6,0	¼ / 6,0	¼ / 6,0		
Pipe diameter - gas side 5)		inch / mm	¾ / 9,5	¾ / 9,5	¾ / 12,0		
Dimension of ID	w x h x d	mm	700x600x215	700x600x215	700x600x215		
Dimension of panel	w x h x d	mm	-	-	-		
Package dimension of ID	w x h x d	mm	788x697x283	788x697x283	788x697x283		
Package dimension of panel	w x h x d	mm	-	-	-		
Weight of ID	netto / brutto	kg	15,5/18,5	15,5/18,5	15,5/18,5		
Weight of panel	netto / brutto	kg	-	-	-		
Set temperature range		°C	16 ~ 30	16 ~ 30	16 ~ 30		
ADDITIONAL TECHNICAL INFORMATION							
Screw holes distance	w x d	mm	See service manual				
Communication cable		mm ²	4 x 0,75				
Recommended power cable 11)		mm ²	Outdoor unit power supplied				
Recommended air switch		A	Outdoor unit power supplied				
EQUIPMENT							
Plasma generator			✓	✓	✓		
Wifi module			✓	✓	✓		
Drain pump			-	-	-		
Max. lift (from bottom of ID unit)		mm	-	-	-		
Dry contact (ON/OFF)			-	-	-		
Alarm contact			-	-	-		
Fresh air inlet			-	-	-		
STANDARD ACCESSORIES							
Standard health filter			SAF-OPWC1, SAF-OPWA1				
Remote controller (IR)			YAA1FB8	YAA1FB8	YAA1FB8		
Wired controller			-	-	-		
OPTIONAL ACCESSORIES							
Optional health filters			SAF-OPWB4, SAF-OPWK4, SAF-OPWM4, SAF-OPWP4, SAF-OPWS4				
Wired controller			SWC-02, XK19				
Central controller			SCC-16, SCC-36				
Other			G2S, G2S-T				

The specification of products is subject to change based on further development of the units by the producer and can be changed without prior notice. Refer to rating label.

R32 (single component refrigerant HFC), GWP of refrigerant used: 675.

Contains fluorinated greenhouse gases covered by the Kyoto Protocol.

Explanatory notes on the very last page of the catalogue.

These indoor units may be combined with other indoor units from MULTI VARIABLE series, it is essential to follow combinations recommended in the combination table.

APPEARANCE AND DIMENSIONS OF INDOOR UNIT

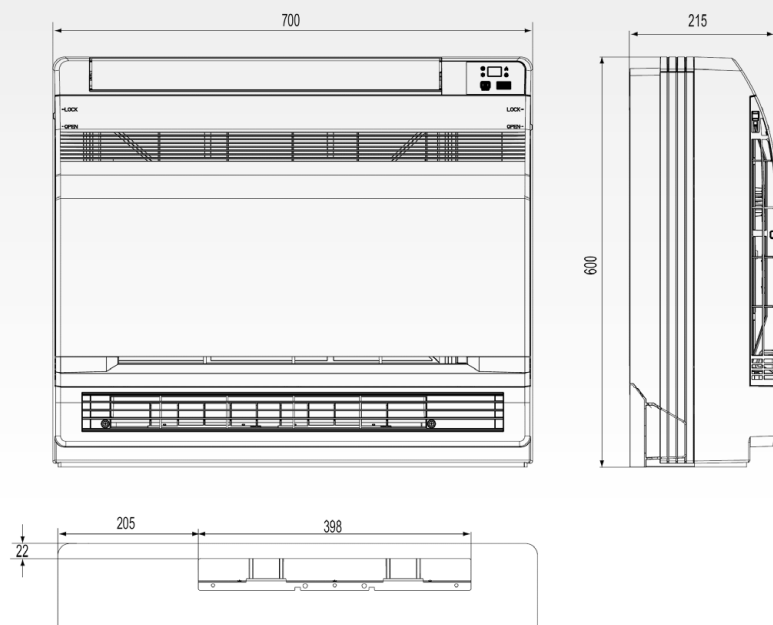

units: mm

4-WAY CASSETTE INDOOR UNITS

MULTI VARIABLE SERIES

MODEL			MV-C12BI	MV-C18BI	MV-C24BI		
Capacity cooling/heating 1)	Nominal	kW	3,5/4,0	4,5/5	7,1/8		
Power supply		Hz / V	1~ / 50 / 220-240	1~ / 50 / 220-240	1~ / 50 / 220-240		
Air flow of ID	SH/H/M/L	m ³ / h	650/560/520/450	710/670/590/450	1280/1220/1100/880		
Sound pressure level of ID at 1,4m 4)	SH/H/M/L	dB(A)	44/41/38/34	47/45/41/35	47/45/41/36		
Sound power of ID 4)	SH/H/M/L	dB(A)	55/52/49/45	58/56/52/46	58/56/52/47		
External static pressure	nom/min-max	Pa	-	-	-		
Dehumidifying volume		l / h	1,4	1,8	2,5		
Refrigerant type		Type	R32	R32	R32		
Pipe diameter - liquid side 5)		inch / mm	¼ / 6,0	¼ / 6,0	¾ / 9,5		
Pipe diameter - gas side 5)		inch / mm	¾ / 9,5	¾ / 12,0	¾ / 16,0		
Dimension of ID	w x h x d	mm	596x240x596	596x240x596	840x240x840		
Dimension of panel	w x h x d	mm	670x50x670	670x50x670	950x60x950		
Package dimension of ID	w x h x d	mm	778x300x778	778x300x778	963x325x963		
Package dimension of panel	w x h x d	mm	763x105x763	763x105x763	1033x133x1038		
Weight of ID	netto / brutto	kg	20/24	20/24	26/32		
Weight of panel	netto / brutto	kg	3,5 / 5,0	3,5 / 5,0	7,0 / 11,0		
Set temperature range		°C	16 ~ 30	16 ~ 30	16 ~ 30		
ADDITIONAL TECHNICAL INFORMATION							
Screw holes distance	w x d	mm	See service manual				
Communication cable		mm ²	4x1,0	4x1,0	4x1,0		
Recommended power cable 11)		mm ²	Outdoor unit power supplied				
Recommended air switch		A	Outdoor unit power supplied				
EQUIPMENT							
Plasma generator			-	-	-		
Wifi module			-	-	-		
Drain pump			✓	✓	✓		
Max. lift (from bottom of ID unit)		mm	500	500	500		
Dry contact (ON/OFF)			✓	✓	✓		
Alarm contact			-	-	-		
Fresh air inlet			✓	✓	✓		
Decorative panel			✓	✓	✓		
STANDARD ACCESSORIES							
Standard health filter			-	-	-		
Remote controller (IR)			YT1F	YT1F	YT1F		
Wired controller			✓	✓	✓		
OPTIONAL ACCESSORIES							
Optional health filters			-				
Wired controller			SWC-02				
Central controller			SCC-16, SCC-36				
Other			G2S, G2S-T				

The specification of products is subject to change based on further development of the units by the producer and can be changed without prior notice. Refer to rating label.

R32 (single component refrigerant HFC), GWP of refrigerant used: 675. Contains fluorinated greenhouse gases covered by the Kyoto Protocol. Explanatory notes on the very last page of the catalogue.

These indoor units may be combined with other indoor units from MULTI VARIABLE series, it is essential to follow combinations recommended in the combination table.

APPEARANCE AND DIMENSIONS OF INDOOR UNIT

MV-C12BI

MV-C18BI

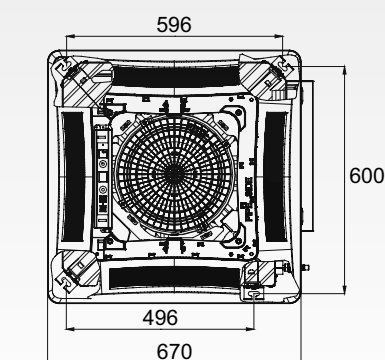

MV-C24BI

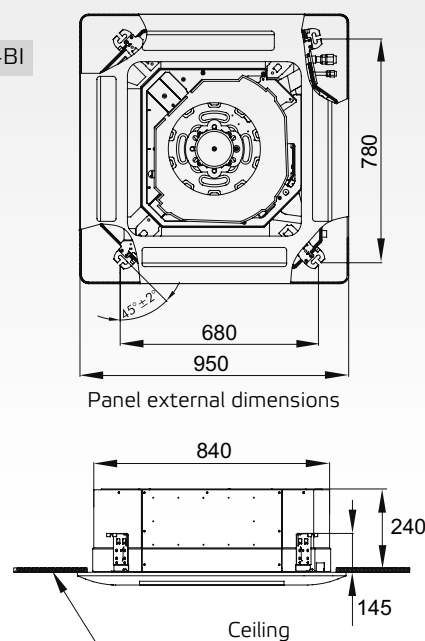

units: mm

MULTI VARIABLE SERIES

MODEL			MV-D09BI	MV-D12BI	MV-D18BI	MV-D24BI	
Capacity cooling/heating 1)	Nominal	kW	2,5/2,8	3,5/3,85	5/5,5	7,1/8	
Power supply		Hz / V	1~ / 50 / 220-240	1~ / 50 / 220-240	1~ / 50 / 220-240	1~ / 50 / 220-240	
Air flow of ID	SH/H/M/L	m ³ / h	450/350/280	550/400/300	700/600/500	1000/750/550	
Sound pressure level of ID at 1,4m 4)	SH/H/M/L	dB(A)	47/41/37/34/31	49/42/39/35/32	51/43/41/33/-	52/44/42/34/-	
Sound power of ID 4)	SH/H/M/L	dB(A)	57/51/47/44/41	59/52/49/45/42	61/53/51/43/-	62/55/52/44/-	
External static pressure	nom/min-max	Pa	25/0-50	25/0-50	25/0-50	25/0-50	
Dehumidifying volume		l / h	0,8	1,4	1,8	2,5	
Refrigerant type		Type	R32	R32	R32	R32	
Pipe diameter - liquid side 5)		inch / mm	¼ / 6,0	¼ / 6,0	¼ / 6,0	¾ / 9,5	
Pipe diameter - gas side 5)		inch / mm	¾ / 9,5	¾ / 9,5	¾ / 12,0	¾ / 16,0	
Dimension of ID	w x h x d	mm	700x200x615	700x200x615	900x200x615	1100x200x615	
Dimension of panel	w x h x d	mm	-	-	-	-	
Package dimension of ID	w x h x d	mm	893x305x743	893x305x743	1123x305x743	1323x305x743	
Package dimension of panel	w x h x d	mm	-	-	-	-	
Weight of ID	netto / brutto	kg	21/26	22/28	26/32	30/40	
Weight of panel	netto / brutto	kg	-	-	-	-	
Set temperature range		°C	16 ~ 30	16 ~ 30	16 ~ 30	16 ~ 30	
ADDITIONAL TECHNICAL INFORMATION							
Screw holes distance	w x d	mm	742x491	742x491	942x491	1142x491	
Communication cable		mm ²	4x1,0	4x1,0	4x1,0	4x1,0	
Recommended power cable 11)		mm ²	Outdoor unit power supplied				
Recommended air switch		A	Outdoor unit power supplied				
EQUIPMENT							
Plasma generator			-	-	-	-	
Wifi module			-	-	-	-	
Drain pump			✓	✓	✓	✓	
Max. lift (from bottom of ID unit)		mm	1000	1000	1000	1000	
Dry contact (ON/OFF)			-	-	-	-	
Alarm contact			-	-	-	-	
Fresh air inlet			-	-	-	-	
STANDARD ACCESSORIES							
Standard health filter			-	-	-	-	
Remote controller (IR)			YT1F	YT1F	YT1F	YT1F	
Wired controller			✓	✓	✓	✓	
OPTIONAL ACCESSORIES							
Optional health filters			-				
Wired controller			SWC-02				
Central controller			SCC-16, SCC-36				
Other			G2S, G2S-T				

The specification of products is subject to change based on further development of the units by the producer and can be changed without prior notice. Refer to rating label.
 R32 (single component refrigerant HFC), GWP of refrigerant used: 675.
 Contains fluorinated greenhouse gases covered by the Kyoto Protocol.
 Explanatory notes on the very last page of the catalogue.
 These indoor units may be combined with other indoor units from MULTI VARIABLE series, it is essential to follow combinations recommended in the combination table.

APPEARANCE AND DIMENSIONS OF INDOOR UNIT

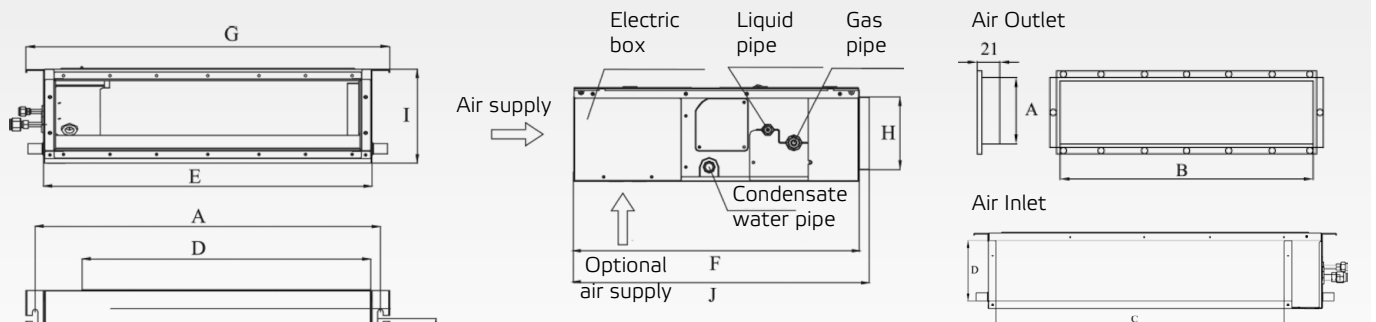

	A	B	C	D	E	F	G	H	I	J
MV-D09BI	742	491	662	620	700	615	782	156	200	635
MV-D12BI	942	491	862	820	900	615	982	156	200	635
MV-D18BI	1142	491	1062	1020	1100	615	1182	156	200	635
AIR OUTLET / AIR INLET	A	B	C	D						
MV-D09BI	156	662	580	162						
MV-D12BI	156	662	580	162						
MV-D18BI	156	862	780	162						
MV-D24BI	156	1062	980	162						

units: mm

FLOOR CEILING INDOOR UNITS

MULTI VARIABLE SERIES

MODEL			MV-F09BI	MV-F12BI	MV-F18BI	MV-F24BI		
Capacity cooling/heating 1)	Nominal	kW	2,6/2,7	3,5/4	4,5/5	7,1/8		
Power supply		Hz / V	1~ / 50 / 220-240	1~ / 50 / 220-240	1~ / 50 / 220-240	1~ / 50 / 220-240		
Air flow of ID	SH/H/M/L	m ³ / h	700/610/540/420	700/610/540/420	680/590/520/410	950/870/800/720		
Sound pressure level of ID at 1m 4)	SH/H/M/L	dB(A)	38/35/30/26	38/35/30/26	38/35/30/26	38/35/30/26		
Sound power of ID 4)	SH/H/M/L	dB(A)	52/49/44/40	52/49/44/40	52/49/44/40	52/49/44/41		
External static pressure	nom/min-max	Pa	-	-	-	-		
Dehumidifying volume		l / h	0,8	1,4	1,8	2,5		
Refrigerant type		Type	R32	R32	R32	R32		
Pipe diameter - liquid side 5)		inch / mm	¼ / 6,0	¼ / 6,0	¼ / 6,0	¼ / 9,5		
Pipe diameter - gas side 5)		inch / mm	¾ / 9,5	¾ / 12,0	¾ / 12,0	¾ / 16,0		
Dimension of ID	w x h x d	mm	870x665x235	870x665x235	870x665x235	1200x665x235		
Dimension of panel	w x h x d	mm	-	-	-	-		
Package dimension of ID	w x h x d	mm	1033x770x300	1033x770x300	1033x770x300	1363x770x300		
Package dimension of panel	w x h x d	mm	-	-	-	-		
Weight of ID	netto / brutto	kg	25/30	25/30	25,5/30,5	33/40		
Weight of panel	netto / brutto	kg	-	-	-	-		
Set temperature range		°C	16 ~ 30	16 ~ 30	16 ~ 30	16 ~ 30		
ADDITIONAL TECHNICAL INFORMATION								
Screw holes distance	w x d	mm	See service manual					
Communication cable		mm ²	4x1,0	4x1,0	4x1,0	4x1,0		
Recommended power cable 11)		mm ²	Outdoor unit power supplied					
Recommended air switch		A	Outdoor unit power supplied					
EQUIPMENT								
Plasma generator			-	-	-	-		
Wifi module			-	-	-	-		
Drain pump			-	-	-	-		
Max. lift (from bottom of ID unit)		mm	-	-	-	-		
Dry contact (ON/OFF)			✓	✓	✓	✓		
Alarm contact			-	-	-	-		
Fresh air inlet			-	-	-	-		
STANDARD ACCESSORIES								
Standard health filter			-	-	-	-		
Remote controller (IR)			YT1F	YT1F	YT1F	YT1F		
Wired controller			✓	✓	✓	✓		
OPTIONAL ACCESSORIES								
Optional health filters			-					
Wired controller			SWC-02					
Central controller			SCC-16, SCC-36					
Other			G2S, G2S-T					

The specification of products is subject to change based on further development of the units by the producer and can be changed without prior notice. Refer to rating label.

R32 (single component refrigerant HFC), GWP of refrigerant used: 675.

Contains fluorinated greenhouse gases covered by the Kyoto Protocol.

Explanatory notes on the very last page of the catalogue.

These indoor units may be combined with other indoor units from MULTI VARIABLE series, it is essential to follow combinations recommended in the combination table.

APPEARANCE AND DIMENSIONS OF INDOOR UNIT

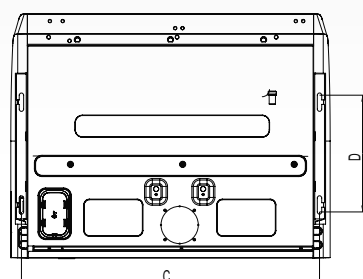
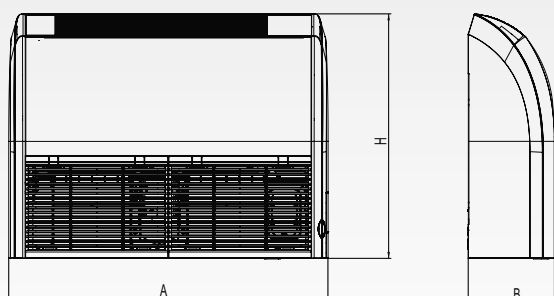

	A	B	C	D	H
MV-F09BI					
MV-F12BI	870	235	812	318	665
MV-F18BI					
MV-F24BI	1200	235	1142	318	665

units: mm

OUTDOOR UNITS

MULTI VARIABLE SERIES

MODEL			MV-E14BI	MV-E18BI	MV-E21BI	MV-E24BI	
Qty of connectable indoor units			1-2	1-2	2-3	2-3	
Capacity cooling/heating 1)	Nominal (min-max)	kW	4,1 (2,1-4,4) / 4,4(2,5-5,4)	5,2 (2,1-5,8) / 5,4 (2,6-5,9)	6,1 (2,2-7,3) / 6,5 (3,6-8,5)	7,1 (2,3-8,5) / 8,5 (3,7-8,8)	
Power supply		Hz / V	1~ / 50 / 220-240	1~ / 50 / 220-240	1~ / 50 / 220-240	1~ / 50 / 220-240	
Power input cooling/heating 1)		W	1200/1180	1450/1300	1740/1600	2180 / 2280	
Maximal power input 2)		W	1780	1780	2870	2870	
Power current cooling/heating		A	5,32/4,53	6,43/5,77	7,72/7,10	9,67 / 10,12	
Maximal power current 2)		A	7,9	7,9	12,7	12,7	
Energy class cooling 3)		-	See table below	See table below	See table below	See table below	
Air flow of OD	H	m ³ / h	2600	2600	3200	4000	
Sound pressure level of OD at 1m 4)	H	dB(A)	55	55	58	58	
Sound power of OD 4)	H	dB(A)	65	65	68	68	
Refrigerant type/charge		Type / kg / t eq. CO ₂	R32 / 1,05 / 0,71	R32 / 1,05 / 0,71	R32 / 1,60 / 1,08	R32 / 1,80 / 1,22	
Additional refrigerant		g / m	20	20	20	20	
Pipe diameter - liquid side 5)		qty x mm	2x6,0	2x6,0	3x6,0	3x6,0	
Pipe diameter - gas side 5)		qty x mm	2x9,5	2x9,5	3x9,5	3x9,5	
Max pipe length without additional refrigerant 6)		m	10	10	30	30	
Maximal pipe length to 1 indoor unit 9)		m	10	10	20	20	
Maximal total pipe length 7)		m	20	20	60	60	
Max. elevation/ Drop height		m	5	5	10	10	
Dimension of OD	w x h x d	mm	908x378x602	908x378x602	963x396x700	1001x790x427	
Package dimension of OD	w x h x d	mm	948x645x420	948x645x420	1029x750x458	1038x855x488	
Weight of OD	netto / brutto	kg	43,0 / 46,0	43,0 / 46,0	55,0 / 59,5	68,0 / 73,0	
Operating temperature range 8)	Cooling	°C	- 15 ~ 43	- 15 ~ 43	- 15 ~ 43	- 15 ~ 43	
	Heating	°C	- 20 ~ 24	- 20 ~ 24	- 20 ~ 24	- 20 ~ 24	
ADDITIONAL TECHNICAL INFORMATION							
Screw holes distance of OD	w x d	mm	550x354	550x354	560x368	610x399	
Communication cable		mm ²	4 x 1,5				
Recommended power cable		mm ²	3x1,5	3x1,5	3x2,5	3x2,5	
Recommended air switch		A	13	13	16	16	
EQUIPMENT							
Throttling method			EXV	EXV	EXV	EXV	
Bottom chassis heater			Heating belt	Heating belt	Heating belt	Heating belt	
Crankcase heater			✓	✓	✓	✓	
Bottom plugs for OD			✓	✓	✓	✓	
Drain pipe connector			✓	✓	✓	✓	
Pipe reduction			✓	✓	✓	✓	

The specification of products is subject to change based on further development of the units by the producer and can be changed without prior notice. Refer to rating label.

R32 (single component refrigerant HFC), GWP of refrigerant used: 675.

Contains fluorinated greenhouse gases covered by the Kyoto Protocol.

Explanatory notes on the very last page of the catalogue.

May not be used separately, must be combined with indoor units from Multi Variable (MV) series.

OUTDOOR UNITS

MULTI VARIABLE SERIES

MODEL			MV-E28BI	MV-E36BI	MV-E42BI		
Qty of connectable indoor units			2-4	2-4	2-5		
Capacity cooling/heating 1)	Nominal (min-max)	kW	8,0 (2,3-10,3) / 9,5 (3,7-10,3)	10,5 (2,1-11,0) / 12,0 (2,6-13,0)	12,1 (2,1-13,6) / 13,0 (2,6-14,0)		
Power supply		Hz / V	1~ / 50 / 220-240	1~ / 50 / 220-240	1~ / 50 / 220-240		
Power input cooling/heating 1)		W	2540 / 2490	3500 / 3750	3590 / 3550		
Maximal power input 2)		W	3580	4880	5300		
Power current cooling/heating		A	15,71 / 11,05	15,42 / 15,20	16,43 / 16,22		
Maximal power current 2)		A	15,9	20,0	20,0		
Energy class cooling 3)		-	See table below	See table below	See table below		
Air flow of OD	H	m ³ / h	4000	7200	7200		
Sound pressure level of OD at 1m 4)	H	dB(A)	58	60	60		
Sound power of OD 4)	H	dB(A)	68	70	70		
Refrigerant type/charge		Type / kg / t eq. CO ₂	R32 / 2,00 / 1,35	R32 / 2,75 / 1,86	R32 / 2,75 / 1,86		
Additional refrigerant		g / m	20	20	20		
Pipe diameter - liquid side 5)		qty x mm	4x6,0	4x6,0	5x6,0		
Pipe diameter - gas side 5)		qty x mm	4x9,5	4x9,5	5x9,5		
Max pipe length without additional refrigerant 6)		m	40	40	40		
Maximal pipe length to 1 indoor unit 9)		m	20	25	25		
Maximal total pipe length 7)		m	70	75	75		
Max. elevation/ Drop height		m	10	15	15		
Dimension of OD	w x h x d	mm	1001x790x427	1087x440x1106	1087x440x1106		
Package dimension of OD	w x h x d	mm	1083x855x488	1158x1235x493	1158x1235x493		
Weight of OD	netto / brutto	kg	69,0 / 74,0	90,0 / 98,0	90,0 / 98,0		
Operating temperature range 8)	Cooling	°C	- 15 ~ 43	- 15 ~ 43	- 15 ~ 43		
	Heating	°C	- 20 ~ 24	- 20 ~ 24	- 20 ~ 24		
ADDITIONAL TECHNICAL INFORMATION							
Screw holes distance of OD	w x d	mm	610x399	631x401	631x401		
Communication cable		mm ²		4 x 1,5			
Recommended power cable		mm ²	3x4,0	3x4,0	3x4,0		
Recommended air switch		A	20	25	25		
EQUIPMENT							
Throttling method			EXV	EXV	EXV		
Bottom chassis heater			Heating belt	Heating belt	Heating belt		
Crankcase heater			✓	✓	✓		
Bottom plugs for OD			✓	✓	✓		
Drain pipe connector			✓	✓	✓		
Pipe reduction			✓	✓	✓		

The specification of products is subject to change based on further development of the units by the producer and can be changed without prior notice. Refer to rating label.

R32 (single component refrigerant HFC), GWP of refrigerant used: 675.

Contains fluorinated greenhouse gases covered by the Kyoto Protocol.

Explanatory notes on the very last page of the catalogue.

May not be used separately, must be combined with indoor units from Multi Variable (MV) series.

	6 mm → 10 mm	10 mm → 12 mm	10 mm → 16 mm		
MV-E14,18BI	-	1x	-		
MV-E21,24,28BI	-	2x	-		
MV-E36BI	2x	4x	2x		
MV-E42BI	2x	4x	3x		

OUTDOOR UNITS

MULTI VARIABLE SERIES

ENERGY CLASS INFORMATION

COOLING						
Outdoor unit	Indoor unit	Energy class	Pdesign cooling (kW)	SEER	Annual power consumption (kWh/a)	
MV-E14BI	2x MV-H07BIF	A++	4,1	6,1	235	
MV-E18BI	2x MV-H09BIF	A++	5,2	6,1	298	
MV-E21BI	3x MV-H07BIF	A++	6,1	6,1	350	
MV-E24BI	2x MV-H09BIF, MV-H07BIF	A++	7,1	6,1	407	
MV-E28BI	4x MV-H07BIF	A++	8,0	6,1	459	
MV-E36BI	4x MV-H09BIF	A++	10,5	6,1	602	
MV-E42BI	4x MV-H09BIF, MV-H07BIF	A++	12,0	6,1	689	
HEATING-AVERAGE CLIMATE						
Outdoor unit	Indoor unit	Energy class	Pdesign heating (kW)	SCOP	Annual power consumption (kWh/a)	
MV-E14BI	2x MV-H07BIF	A+	3,8	4,0	1330	
MV-E18BI	2x MV-H09BIF	A+	3,8	4,0	1330	
MV-E21BI	3x MV-H07BIF	A+	6,1	4,0	2135	
MV-E24BI	2x MV-H09BIF, MV-H07BIF	A+	6,1	4,0	2135	
MV-E28BI	4x MV-H07BIF	A+	7,2	4,0	2520	
MV-E36BI	4x MV-H09BIF	A+	10,5	4,0	3675	
MV-E42BI	4x MV-H09BIF, MV-H07BIF	A+	11,8	4,0	4130	

OUTDOOR UNITS

MULTI VARIABLE SERIES

COMBINATION TABLES

(unit: x1000Btu/h)

MV-E14BI		MV-E21BI		MV-E24BI			MV-E28BI
1 UNIT	2 UNITS	2 UNITS	3 UNITS	2 UNITS	3 UNITS		2 UNITS
7	7+7	7+7	7+7+7	7+7	7+7+7	7+7+18	7+7
9	7+12	7+12	7+7+12	7+12	9+9+12	7+9+18	7+12
12	7+9	9+9	7+7+9	9+9	7+7+9	12+12+12*	9+9
	9+9	7+9	7+9+9	9+18	7+9+9	7+12+12	9+18
	9+12	7+18	9+9+9	12+18	7+7+12	9+9+18*	12+18
		9+12	7+9+12	7+9	7+9+12	9+12+12*	7+9
MV-E18BI							
1 UNIT	2 UNITS	9+18	7+12+12	7+18	9+9+9		7+18
7	7+7	12+12	9+9+12	9+12			9+12
9	7+12	12+18	12+12+12*	12+12			12+12
12	9+12			18+18			18+18
	7+9						
	9+9						
MV-E28BI		MV-E36BI					
3 UNITS		4 UNITS	2 UNITS		3 UNITS		
7+7+7	7+12+18	7+7+7+7	7+7	9+24	7+7+7	7+12+18	9+12+18
7+7+9	9+9+9	7+7+7+9	7+9	12+12	7+7+9	7+12+24	9+12+24
7+7+12	9+9+12	7+7+9+9	7+12	12+18	7+7+12	7+18+18	9+18+18
7+7+18	9+9+18	9+9+9+9	7+18	12+24	7+7+18	7+18+24*	9+18+24*
7+9+9	9+12+18	7+7+7+12	7+24	18+18	7+7+24	9+9+9	12+12+12
7+9+12	9+12+12	7+7+9+12	9+9	18+24	7+9+9	9+9+12	12+12+18
7+9+18	12+12+12	7+9+9+9	9+12	24+24*	7+9+12	9+9+18	12+12+24
7+12+12	12+12+18	7+7+7+18	9+18		7+9+18	9+9+24	12+18+18
		7+7+9+18			7+9+24	9+12+12	18+18+18*
		7+9+9+12			7+12+12		
		9+9+12+12					
		7+7+12+12					
		9+9+9+12					
MV-E36BI		MV-E42BI					
4 UNITS		2 UNITS		3 UNITS			
7+7+7+7	7+7+18+18*	9+9+9+9	7+7	9+24	7+7+7	7+12+24	9+18+18
7+7+7+9	7+9+9+9	9+9+9+12	7+9	12+12	7+7+9	7+18+18	9+18+24
7+7+7+12	7+9+9+12	9+9+9+18	7+12	12+18	7+7+12	7+18+24	9+24+24
7+7+7+18	7+9+9+18	9+9+12+12	7+18	12+24	7+7+18	7+24+24	12+12+12
7+7+7+24	7+9+9+24*	9+12+12+12	7+24	18+18	7+7+24	9+9+9	12+12+18
7+7+9+9	7+9+12+12	9+9+9+24*	9+9	18+24	7+9+9	9+9+12	12+12+24
7+7+9+12	7+9+12+18	9+9+12+18	9+12	24+24	7+9+12	9+9+18	12+18+18
7+7+9+18	7+9+18+18*	9+9+18+18*	9+18		7+9+18	9+9+24	12+18+24
7+7+9+24	7+12+12+12	9+12+12+18*			7+9+24	9+12+12	18+18+18
7+7+12+12	7+12+12+18	12+12+12+12			7+12+12	9+12+18	12+24+24*
7+7+12+18					7+12+18	9+12+24	18+18+24
7+7+12+24							
MV-E42BI		MV-E48BI					
4 UNITS		5 UNITS					
7+7+7+7	7+7+18+18	9+9+9+12	7+9+18+24	7+7+7+7+7	7+7+9+9+12	9+9+9+9+18	7+9+9+12+18
7+7+7+9	7+9+9+9	9+9+9+18	7+12+12+24	7+7+7+7+9	7+7+9+9+18	9+9+9+12+12	7+9+9+12+24*
7+7+7+12	7+9+9+12	9+9+9+24	7+12+18+18	7+7+7+7+12	7+7+9+12+12	9+9+12+12+12	7+9+9+18+18
7+7+7+18	7+9+9+18	9+9+12+12	7+12+18+24	7+7+7+7+18	7+7+9+12+18	9+9+12+12+18*	7+9+12+12+18
7+7+7+24	7+9+9+24	9+9+12+18	7+18+18+18	7+7+7+7+24	7+7+12+12+12	7+7+7+12+24	7+12+12+12+12
7+7+9+9	7+9+12+12	9+9+12+24	9+9+18+24	7+7+7+9+9	7+9+9+9+9	7+7+7+18+18	7+12+12+12+18
7+7+9+12	7+9+12+18	9+9+18+18	9+12+12+24	7+7+7+9+12	7+9+9+9+12	7+7+9+9+24	9+9+9+9+24
7+7+9+18	7+9+12+24*	9+12+12+12*	9+12+18+18	7+7+7+9+18	7+9+9+9+18	7+7+9+12+24	9+9+9+12+18
7+7+9+24	7+9+18+18	9+12+12+18	9+18+18+18	7+7+7+9+24	7+9+9+12+12	7+7+9+18+18	9+9+9+18+18*
7+7+12+12	7+12+12+12	12+12+12+12	12+12+18+18	7+7+7+12+12	7+9+12+12+12	7+7+12+12+18	9+12+12+12+12
7+7+12+18	7+12+12+18	12+12+12+18	12+12+12+24	7+7+7+12+18	9+9+9+9+9	7+7+12+18+18	9+12+12+12+18*
7+7+12+24	9+9+9+9	7+7+18+24		7+7+9+9+9	9+9+9+9+12	7+9+9+9+24	12+12+12+12+12

*This combinations of indoor units capacities exceed 130% of maximum capacity of the outdoor unit.

APPEARANCE AND DIMENSIONS OF OUTDOOR UNIT

MV-E14BI, MV-E18BI

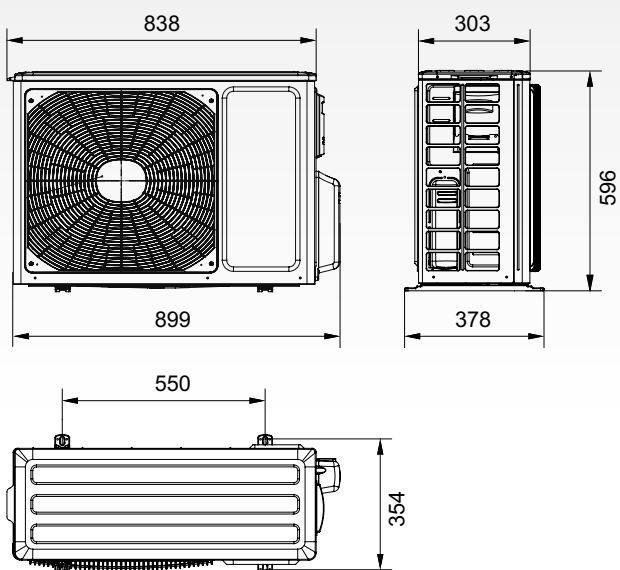

MV-E21BI

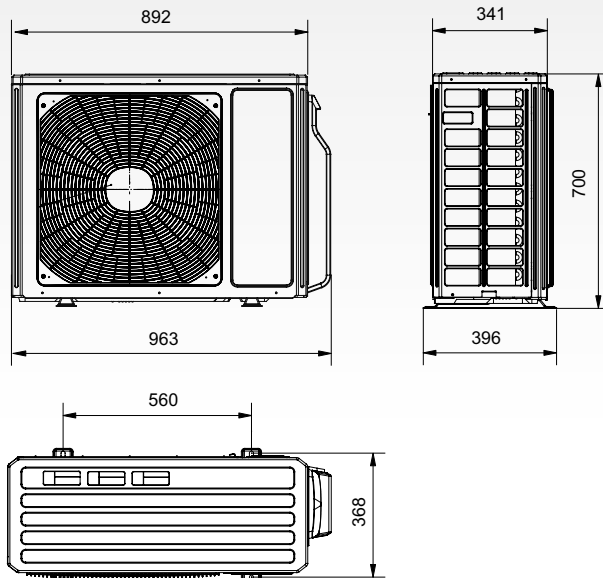

MV-E24BI, MV-E28BI

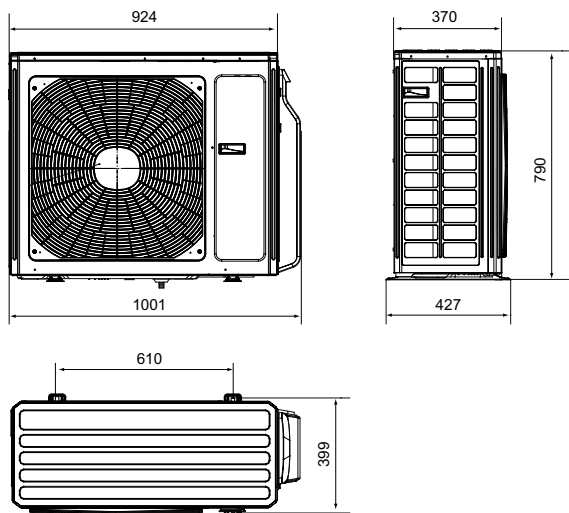

MV-E36BI, MV-E42BI

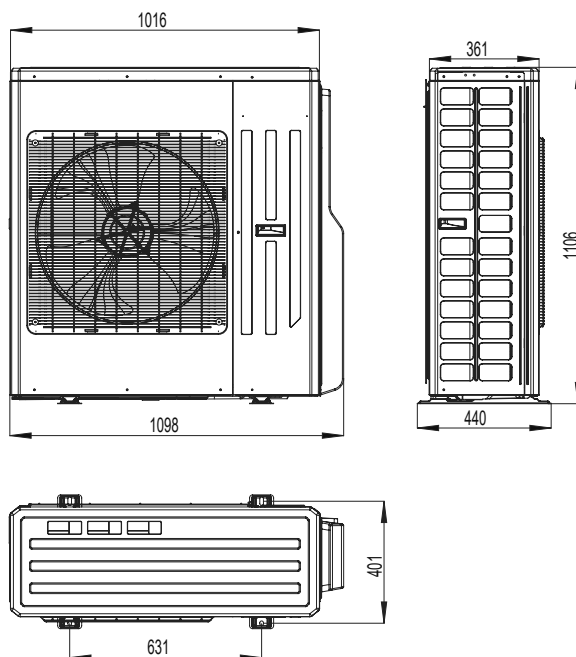

units: mm

ELECTRICAL WIRING DIAGRAM

MULTI VARIABLE SERIES

MV-E14BI, MV-E18BI

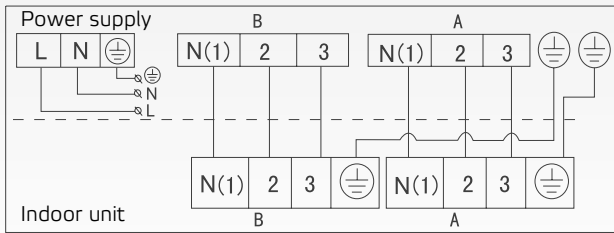

MV-E21BI

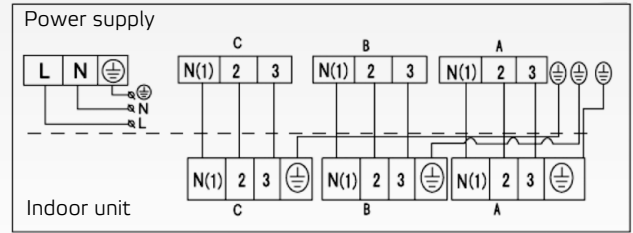

MV-E24BI

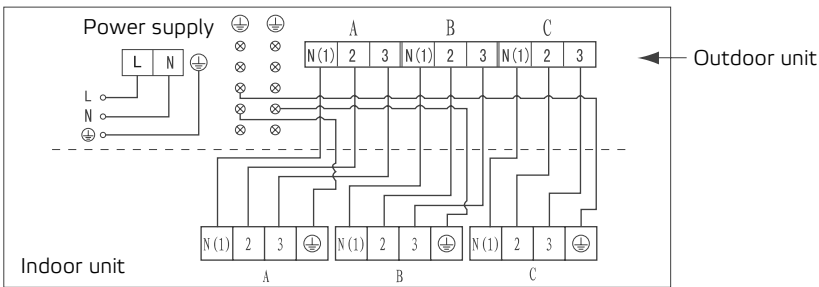

MV-E28BI

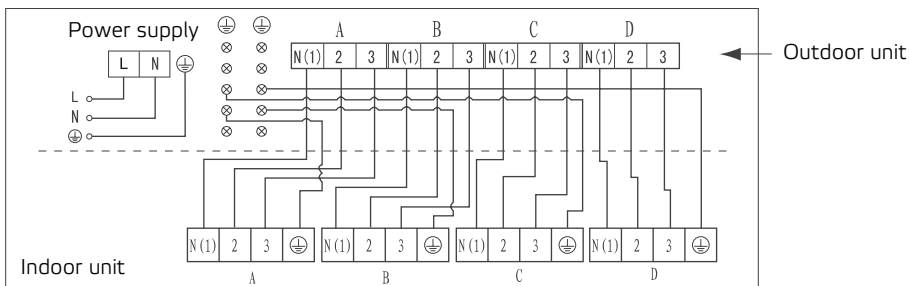

MV-E36BI

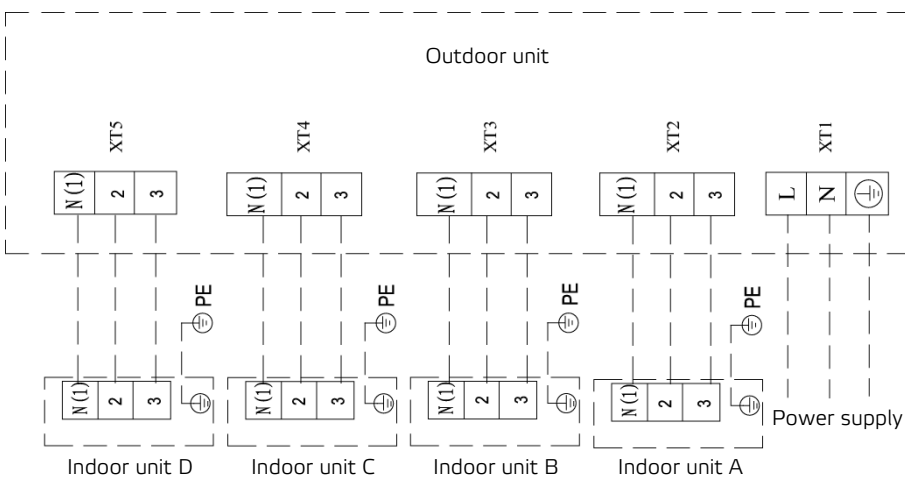

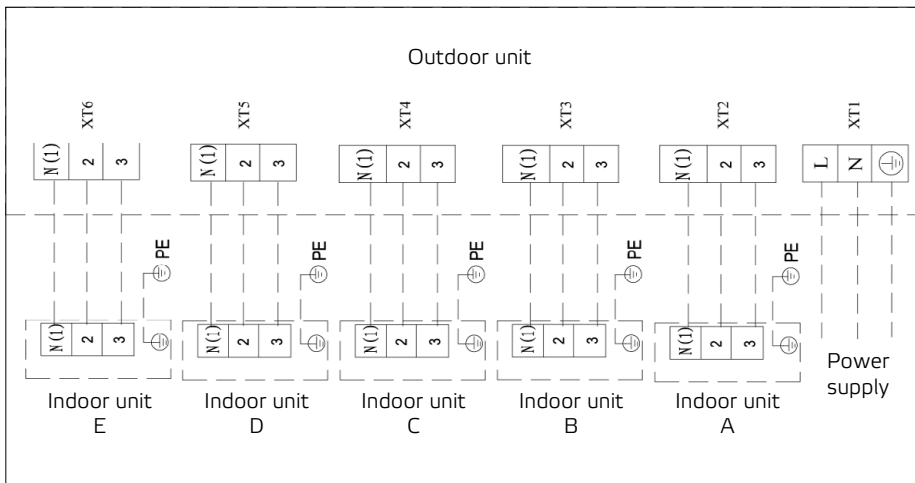

OUTDOOR UNITS

HIGH POWER MULTI SYSTEM SERIES

MODEL			MS-E48AIN	MS-E56AIN		
Qty of connectable indoor units		-	2-8	2-9		
Capacity cooling/heating 1)	Nominal (min-max)	kW	14,0 (1,0-16,0) / 16,0 (1,2-17,4)	16,0 (1,0-18,0) / 18,0 (1,2-19,0)		
Power supply		Hz / V	3~ / 50 / 380-415	3~ / 50 / 380-415		
Power input cooling/heating 1)		W	4600 / 4250	5200 / 4700		
Maximal power input 2)		W	6000	6500		
Power current cooling/heating		A	9,0 / 8,4	9,5 / 8,5		
Maximal power current 2)		A	12	12		
EER/COP 10)		-	2,7/3,2	2,65/3,5		
Air flow of ID	H	m ³ / h	7000	7000		
Sound pressure of ID 4)	H	dB(A)	58	58		
Sound power of ID 4)	H	dB(A)	-	-		
Refrigerant type/charge		Type / kg / t eq. CO ₂	R410A / 4,95 / 10,33	R410A / 4,95 / 10,33		
Additional refrigerant		g / m	depend on calculation	depend on calculation		
Pipe diameter - liquid side 5)		inch / mm	¾ / 9,5	¾ / 9,5		
Pipe diameter - gas side 5)		inch / mm	¾ / 15,9	¾ / 19,1		
Max pipe length without additional refrigerant 6)		m	30	30		
Max. total pipe length (ΣL+ΣA) 7)		m	135	145		
Max. total pipe length between OD and Dbox (ΣL)		m	55	55		
Max. total pipe length between Dbox and ID (ΣA)		m	80	90		
Pipe length between Dbox and ID (A1,2,...)		m	15	15		
Max. height between OD and Dbox (H1) and ID (H2)		m	30	30		
Max. height between DBoxes or IDs (H3)		m	15	15		
Dimension of ID	w x h x d	mm	900x1345x340	900x1345x340		
Package dimension of ID	w x h x d	mm	993x1500x453	993x1500x453		
Weight of ID	netto / brutto	kg	116/125	116/125		
Operating temperature range cooling 8)		°C	18-48	18-48		
Operating temperature range heating 8)		°C	-10-24	-10-24		

ADDITIONAL TECHNICAL INFORMATION

Screw holes distance of OD	w x d	mm	572x378	572x378		
Communication cable		mm ²	2x1,5	2x1,5		
Recommended power cable		mm ²	5x4,0	5x4,0		
Recommended air switch		A	20	20		

EQUIPMENT

Throttling method			-	-		
Bottom chassis heater			-	-		
Crankcase heater			Heating belt	Heating belt		
Bottom plugs for OD			✓	✓		
Drain pipe connector			✓	✓		
Pipe reduction			✓	✓		

The specification of products is subject to change based on further development of the units by the producer and can be changed without prior notice. Refer to rating label.

R410A (50% HFC-32, 50% HFC-125), GWP 2088

Contains fluorinated greenhouse gases covered by the Kyoto Protocol.

Explanatory notes on the very last page of the catalogue.

May not be used separately, must be combined with indoor units from multi split series (MV, MS, MC). For using 2-3 distribution boxes in one system it is necessary to use MS-01BI joints.

DISTRIBUTION BOXES

MODEL			DB2-195B	DB3-195B	DB5-16AF
Maximum number of connectable indoor units		-	2	3	5
Power Supply		Hz / V	1~ / 50 / 220-240	1~ / 50 / 220-240	1~ / 50 / 220-240
Connection port to outdoor unit liquid / gas		mm	9,7 / 19,3	9,7 / 19,3	9,7 / 16,3
Connection port to indoor unit liquid / gas		mm	2x 6,4 / 16,3	3x 6,4 / 16,3	5x 6,4 / 9,5
Connection Method		-	braze	braze	flare
Sound pressure level 4)		dB(A)	28	28	30
Sound power level 4)		dB(A)	-	-	-
Unit dimensions	w x h x d	mm	600x313x182	600x313x182	617x410x193
Package dimensions	w x h x d	mm	683x392x270	683x392x270	676x473x275
Weight	netto / brutto	kg	5,5 / 7,5	6,0 / 8,0	9,0 / 11,0

ADDITIONAL TECHNICAL INFORMATION

Screw holes distance	w x d	mm	383x263	383x263	463x338
Communication cable		mm ²	2x1,5	2x1,5	2x1,5
Recommended power cable		mm ²	3x1,5	3x1,5	3x1,5
Recommended air switch		A	C10	C10	C10

For using 2-3 distribution boxes in one system it is necessary to use MS-01BI joints.

DISTRIBUTION BOXES ADDRESS SETTINGS

Position	Address
	Distribution box 1
	Distribution box 2
	Distribution box 3

OUTDOOR UNITS

HIGH POWER MULTI SYSTEM SERIES

COMBINATION TABLE

(unit: x1000Btu/h)

MS-E48AIN						
2 UNITS						
7+18	9+18	12+12	12+24	18+18	18+24	24+24
7+24	9+24	12+18				
3 UNITS						
7+7+12	7+9+18	7+18+18	9+9+18	9+12+24	12+12+12	12+18+24
7+7+18	7+9+24	7+18+24	9+9+24	9+18+18	12+12+18	12+24+24
7+7+24	7+12+12	7+24+24	9+12+12	9+18+24	12+12+24	18+18+18
7+9+9	7+12+18	9+9+9	9+12+18	9+24+24	12+18+18	18+18+24
7+9+12	7+12+24	9+9+12				
4 UNITS						
7+7+7+7	7+7+9+24	7+9+9+9	7+9+18+18	7+12+18+24	9+9+12+18	9+12+18+18
7+7+7+9	7+7+12+12	7+9+9+12	7+9+18+24	7+18+18+18	9+9+12+24	9+12+18+24
7+7+7+12	7+7+12+18	7+9+9+18	7+9+24+24	9+9+9+9	9+9+18+18	9+18+18+18
7+7+7+18	7+7+12+24	7+9+9+24	7+12+12+12	9+9+9+12	9+9+18+24	12+12+12+12
7+7+7+24	7+7+18+18	7+9+12+12	7+12+12+18	9+9+9+18	9+12+12+12	12+12+12+18
7+7+9+9	7+7+18+24	7+9+12+18	7+12+12+24	9+9+9+24	9+12+12+18	12+12+12+24
7+7+9+12	7+7+24+24	7+9+12+24	7+12+18+18	9+9+12+12	9+12+12+24	12+12+18+18
7+7+9+18						
5 UNITS						
7+7+7+7+7	7+7+7+9+24	7+7+9+9+18	7+7+12+12+24	7+9+9+12+18	7+12+12+12+18	9+9+9+12+24
7+7+7+7+9	7+7+7+12+12	7+7+9+9+24	7+7+12+18+18	7+9+9+12+24	9+9+9+9+9	9+9+9+18+18
7+7+7+7+12	7+7+7+12+18	7+7+9+12+12	7+9+9+9+9	7+9+9+18+18	9+9+9+9+12	9+9+12+12+12
7+7+7+7+18	7+7+7+12+24	7+7+9+12+18	7+9+9+9+12	7+9+12+12+12	9+9+9+9+18	9+9+12+12+18
7+7+7+7+24	7+7+7+18+18	7+7+9+12+24	7+9+9+9+18	7+9+12+12+18	9+9+9+9+24	9+12+12+12+12
7+7+7+9+9	7+7+7+18+24	7+7+9+18+18	7+9+9+9+24	7+9+12+12+24	9+9+9+12+12	9+12+12+12+18
7+7+7+9+12	7+7+9+9+9	7+7+12+12+12	7+9+9+12+12	7+12+12+12+12	9+9+9+12+18	12+12+12+12+12
7+7+7+9+18	7+7+9+9+12	7+7+12+12+18				
6 UNITS						
7+7+7+7+7+7	7+7+7+7+9+12	7+7+7+7+18+18	7+7+7+9+12+18	7+7+9+9+12+12	7+9+9+9+9+18	9+9+9+9+9+9
7+7+7+7+7+9	7+7+7+7+9+18	7+7+7+9+9+9	7+7+7+12+12+12	7+7+9+9+12+18	7+9+9+9+12+12	9+9+9+9+9+12
7+7+7+7+7+12	7+7+7+7+9+24	7+7+7+9+9+12	7+7+7+12+12+18	7+7+9+12+12+12	7+9+9+9+12+18	9+9+9+9+9+18
7+7+7+7+7+18	7+7+7+7+12+12	7+7+7+9+9+18	7+7+9+9+9+9	7+7+12+12+12+12	7+9+9+12+12+12	9+9+9+9+12+12
7+7+7+7+7+24	7+7+7+7+12+18	7+7+7+9+9+24	7+7+9+9+9+12	7+9+9+9+9+9	7+9+12+12+12+12	9+9+9+12+12+12
7+7+7+7+9+9	7+7+7+7+12+24	7+7+7+9+12+12	7+7+9+9+9+18	7+9+9+9+9+12		
7 UNITS						
7+7+7+7+7+7+7	7+7+7+7+7+7+18	7+7+7+7+7+9+18	7+7+7+7+9+9+12	7+7+7+7+12+12+12	7+7+7+9+9+12+12	7+9+9+9+9+9+9
7+7+7+7+7+7+9	7+7+7+7+7+9+9	7+7+7+7+7+12+12	7+7+7+7+9+9+18	7+7+7+9+9+9+9	7+7+9+9+9+9+9	7+9+9+9+9+9+12
7+7+7+7+7+7+12	7+7+7+7+7+9+12	7+7+7+7+9+9+9	7+7+7+7+9+12+12	7+7+9+9+9+9+12	7+7+9+9+9+9+12	9+9+9+9+9+9+9
8 UNITS						
7+7+7+7+7+7+7+7	7+7+7+7+7+7+7+9	7+7+7+7+7+7+7+12	7+7+7+7+7+7+9+9	7+7+7+7+7+7+9+12	7+7+7+7+7+9+9+9	7+7+7+7+7+9+9+9
7+9+9+9+9+9+9+9						

When connecting other than recommended combinations, the system will not work.

OUTDOOR UNITS

HIGH POWER MULTI SYSTEM SERIES

COMBINATION TABLE

(unit: x1000Btu/h)

MS-E56AIN						
2 UNITS						
7+18	9+18	12+18	12+24	18+18	18+24	24+24
7+24	9+24					
3 UNITS						
7+7+18	7+12+12	7+24+24	9+12+12	9+18+24	12+12+24	18+18+18
7+7+24	7+12+18	9+9+12	9+12+18	9+24+24	12+18+18	18+18+24
7+9+12	7+12+24	9+9+18	9+12+24	12+12+12	12+18+24	18+24+24
7+9+18	7+18+18	9+9+24	9+18+18	12+12+18	12+24+24	24+24+24
7+9+24	7+18+24					
4 UNITS						
7+7+7+7	7+7+12+12	7+9+9+24	7+12+12+24	9+9+9+24	9+12+12+18	12+12+12+18
7+7+7+9	7+7+12+18	7+9+12+12	7+12+18+18	9+9+12+12	9+12+12+24	12+12+12+24
7+7+7+12	7+7+12+24	7+9+12+18	7+12+18+24	9+9+12+18	9+12+18+18	12+12+18+18
7+7+7+18	7+7+18+18	7+9+12+24	7+18+18+18	9+9+12+24	9+12+18+24	12+12+18+24
7+7+7+24	7+7+18+24	7+9+18+18	7+18+18+24	9+9+18+18	9+12+24+24	12+12+24+24
7+7+9+9	7+7+24+24	7+9+18+24	7+18+24+24	9+9+18+24	9+18+18+18	12+18+18+18
7+7+9+12	7+9+9+9	7+9+24+24	9+9+9+9	9+9+24+24	9+18+18+24	12+18+18+24
7+7+9+18	7+9+9+12	7+12+12+12	9+9+9+12	9+12+12+12	12+12+12+12	18+18+18+18
7+7+9+24	7+9+9+18	7+12+12+18	9+9+9+18			
5 UNITS						
7+7+7+7+7	7+7+7+12+24	7+7+9+18+18	7+9+9+9+18	7+9+12+18+18	9+9+9+9+24	9+9+12+18+24
7+7+7+7+9	7+7+7+18+18	7+7+9+18+24	7+9+9+9+24	7+9+12+18+24	9+9+9+12+12	9+9+18+18+18
7+7+7+7+12	7+7+7+18+24	7+7+9+24+24	7+9+9+12+12	7+9+18+18+18	9+9+9+12+18	9+12+12+12+12
7+7+7+7+18	7+7+7+24+24	7+7+12+12+12	7+9+9+12+18	7+12+12+12+12	9+9+9+12+24	9+12+12+12+18
7+7+7+7+24	7+7+9+9+9	7+7+12+12+18	7+9+9+12+24	7+12+12+12+18	9+9+9+18+18	9+12+12+12+24
7+7+7+9+9	7+7+9+9+12	7+7+12+12+24	7+9+9+18+18	7+12+12+12+24	9+9+9+18+24	9+12+12+18+18
7+7+7+9+12	7+7+9+9+18	7+7+12+18+18	7+9+9+18+24	7+12+12+18+18	9+9+12+12+12	12+12+12+12+12
7+7+7+9+18	7+7+9+9+24	7+7+12+18+24	7+9+12+12+12	9+9+9+9+9	9+9+12+12+18	12+12+12+12+18
7+7+7+9+24	7+7+9+12+12	7+7+18+18+18	7+9+12+12+18	9+9+9+9+12	9+9+12+12+24	12+12+12+12+24
7+7+7+12+12	7+7+9+12+18	7+9+9+9+9	7+9+12+12+24	9+9+9+9+18	9+9+12+18+18	12+12+12+18+18
7+7+7+12+18	7+7+9+12+24	7+9+9+9+12				
6 UNITS						
7+7+7+7+7+7	7+7+7+7+12+18	7+7+7+9+18+18	7+7+9+9+9+24	7+9+9+9+9+9	7+9+9+12+12+18	9+9+9+9+12+18
7+7+7+7+7+9	7+7+7+7+12+24	7+7+7+9+18+24	7+7+9+9+12+12	7+9+9+9+9+12	7+9+12+12+12+12	9+9+9+9+12+24
7+7+7+7+7+12	7+7+7+7+18+18	7+7+7+12+12+12	7+7+9+9+12+18	7+9+9+9+9+18	7+9+12+12+12+18	9+9+9+9+18+18
7+7+7+7+7+18	7+7+7+9+9+9	7+7+7+12+12+18	7+7+9+9+12+24	7+9+9+9+9+24	7+12+12+12+12+12	9+9+9+12+12+12
7+7+7+7+7+24	7+7+7+9+9+12	7+7+7+12+12+24	7+7+9+9+18+18	7+9+9+9+12+12	9+9+9+9+9+9	9+9+9+12+12+18
7+7+7+7+9+9	7+7+7+9+9+18	7+7+7+12+18+18	7+7+9+12+12+12	7+9+9+9+12+18	9+9+9+9+12	9+9+12+12+12+12
7+7+7+7+9+12	7+7+7+9+9+24	7+7+9+9+9+9	7+7+9+12+12+18	7+9+9+9+12+24	9+9+9+9+18	9+9+12+12+12+18
7+7+7+7+9+18	7+7+7+9+12+12	7+7+9+9+9+12	7+7+9+12+12+24	7+9+9+9+18+18	9+9+9+9+24	9+12+12+12+12+12
7+7+7+7+9+24	7+7+7+9+12+18	7+7+9+9+9+18	7+7+9+12+18+18	7+9+9+12+12+12	9+9+9+9+12+12	12+12+12+12+12+12
7+7+7+7+12+12	7+7+7+9+12+24					
7 UNITS						
7+7+7+7+7+7+7	7+7+7+7+7+9+18	7+7+7+7+9+9+12	7+7+7+9+9+9+9	7+7+7+9+12+12+18	7+7+9+9+12+12+12	7+9+9+9+12+12+12
7+7+7+7+7+7+9	7+7+7+7+7+9+24	7+7+7+7+9+9+18	7+7+7+9+9+9+12	7+7+7+12+12+12+12	7+7+9+12+12+12+12	9+9+9+9+9+9+9
7+7+7+7+7+7+12	7+7+7+7+7+12+12	7+7+7+7+9+9+24	7+7+7+9+9+9+18	7+7+9+9+9+9+9	7+9+9+9+9+9+9	9+9+9+9+9+9+12
7+7+7+7+7+7+18	7+7+7+7+7+12+18	7+7+7+7+9+12+12	7+7+7+9+9+9+24	7+7+9+9+9+9+12	7+9+9+9+9+9+12	9+9+9+9+9+9+18
7+7+7+7+7+7+24	7+7+7+7+7+12+24	7+7+7+7+9+12+18	7+7+7+9+9+12+12	7+7+9+9+9+9+18	7+9+9+9+9+9+18	9+9+9+9+9+12+12
7+7+7+7+7+9+9	7+7+7+7+7+18+18	7+7+7+7+12+12+12	7+7+7+9+9+12+18	7+7+9+9+9+12+12	7+9+9+9+9+12+12	9+9+9+9+12+12+12
7+7+7+7+7+9+12	7+7+7+7+9+9+9	7+7+7+7+12+12+18	7+7+7+9+12+12+12	7+7+9+9+9+12+18		
8 UNITS						
7+7+7+7+7+7+7+7	7+7+7+7+7+7+9+9	7+7+7+7+7+7+12+18	7+7+7+7+7+9+12+12	7+7+7+7+9+9+9+12	7+7+7+9+9+9+9+12	7+7+9+9+9+9+9+12
7+7+7+7+7+7+7+9	7+7+7+7+7+7+9+12	7+7+7+7+7+9+9+9	7+7+7+7+7+12+12+12	7+7+7+7+9+9+12+12	7+7+7+9+9+9+12+12	7+9+9+9+9+9+9+9
7+7+7+7+7+7+7+12	7+7+7+7+7+7+9+18	7+7+7+7+7+9+9+12	7+7+7+7+9+9+9+9	7+7+7+9+9+9+9+9	7+7+9+9+9+9+9+9	9+9+9+9+9+9+9+9
7+7+7+7+7+7+7+18	7+7+7+7+7+7+12+12	7+7+7+7+7+9+9+18				
9 UNITS						
7+7+7+7+7+7+7+7+7	7+7+7+7+7+7+7+7+12	7+7+7+7+7+7+7+9+9	7+7+7+7+7+7+7+9+12	7+7+7+7+7+7+9+9+9	7+7+7+7+7+7+9+9+12	7+7+7+7+7+9+9+9+9
7+7+7+7+7+7+7+7+9						

When connecting other than recommended combinations, the system will not work.

ALLOWED LENGTH AND DROP HEIGHT OF CONNECTION PIPE

HIGH POWER MULTI SYSTEM SERIES

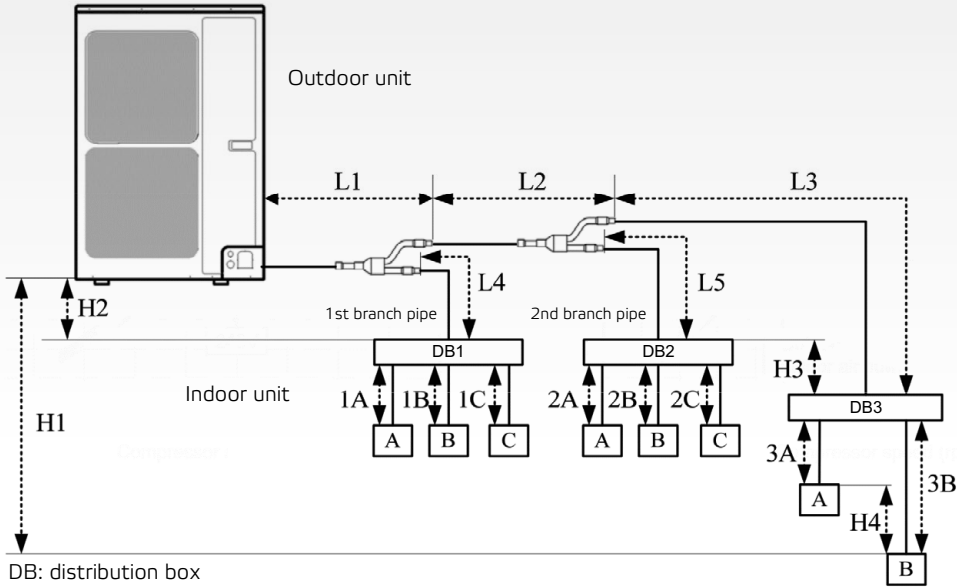

MAXIMUM LENGTH OF CONNECTION PIPES

		The pipes	Length (m)
Maximal allowed length	Total length between outdoor unit and distribution boxes	$L1+L2+L3+L4+L5$	≤ 55
	Total length between indoor unit and distribution box	MS-E48AIN	≤ 80
		MS-E56AIN	≤ 90
	Between indoor unit and distribution box	$1A; 1B; 1C; 2A; 2B; 2C; 3A; 3B$	≤ 15
Maximal allowed length	Between indoor unit and the 1st branch	$L4+1B; L2+L5+2A; L2+L3+3B$	≤ 40
	Between outdoor and indoor units	H1	≤ 30
	Between outdoor unit and distribution box	H2	≤ 30
	Between distribution box and other distribution boxes	H3	≤ 15
	Between indoor unit and other indoor units	H4	≤ 15
Minimal allowed length	Between outdoor unit and the 1st branch	L1	≥ 5
	Between distribution box and branch pipe	L3; L4; L5	As short as possible

Distribution box should be placed within the level between outdoor unit and indoor unit

DIMENSION OF CONNECTION PIPES

		Gas pipe (mm)	Liquid pipe (mm)
Outdoor unit	MS-E48AIN	$\phi 15,9$	$\phi 9,52$
	MS-E56AIN	$\phi 19,05$	$\phi 9,52$
Between outdoor unit and the 1st branch	Pipe L1	$\phi 19,05$	$\phi 9,52$
Between the 1st and the 2nd branch	Pipe L2	$\phi 15,9$	$\phi 9,52$

APPEARANCE AND DIMENSIONS OF OUTDOOR UNIT

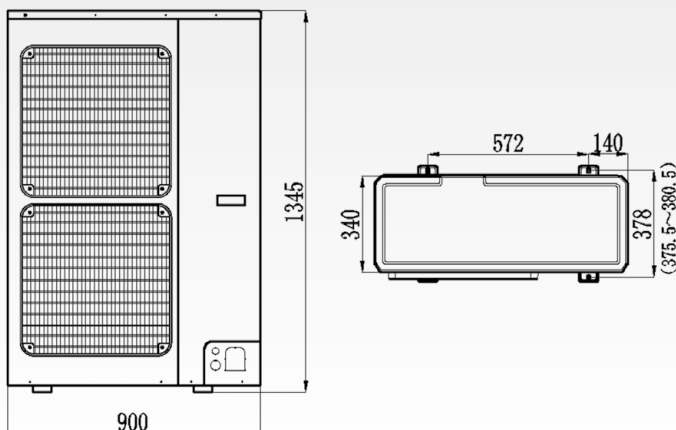

units: mm

APPEARANCE AND DIMENSIONS OF DISTRIBUTION BOXES

HIGH POWER MULTI SYSTEM SERIES

DB2-19SB

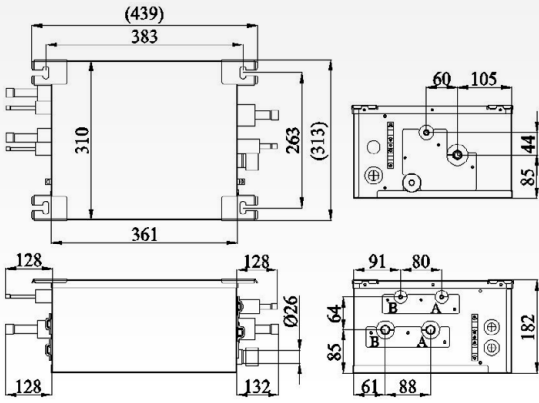

DB3-19SB

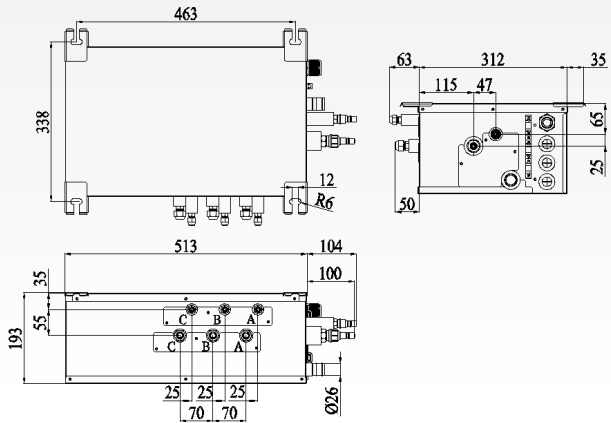

DB5-16AF

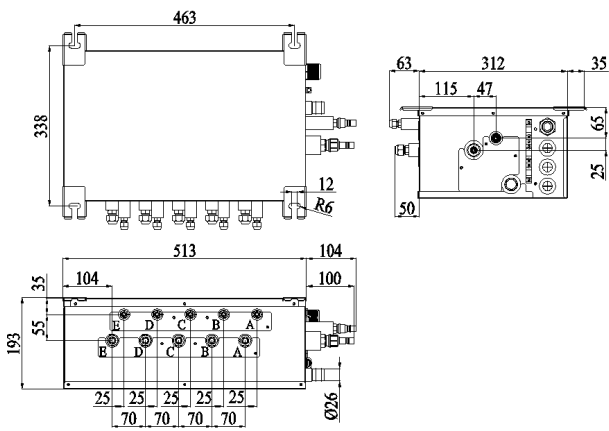

units: mm

ELECTRICAL WIRING DIAGRAM

- Power cable for outdoor unit and distribution boxes (3-core)
- Refrigerant connection pipe
- Communication cable (2-core)
- Power cable for indoor unit (4-core)

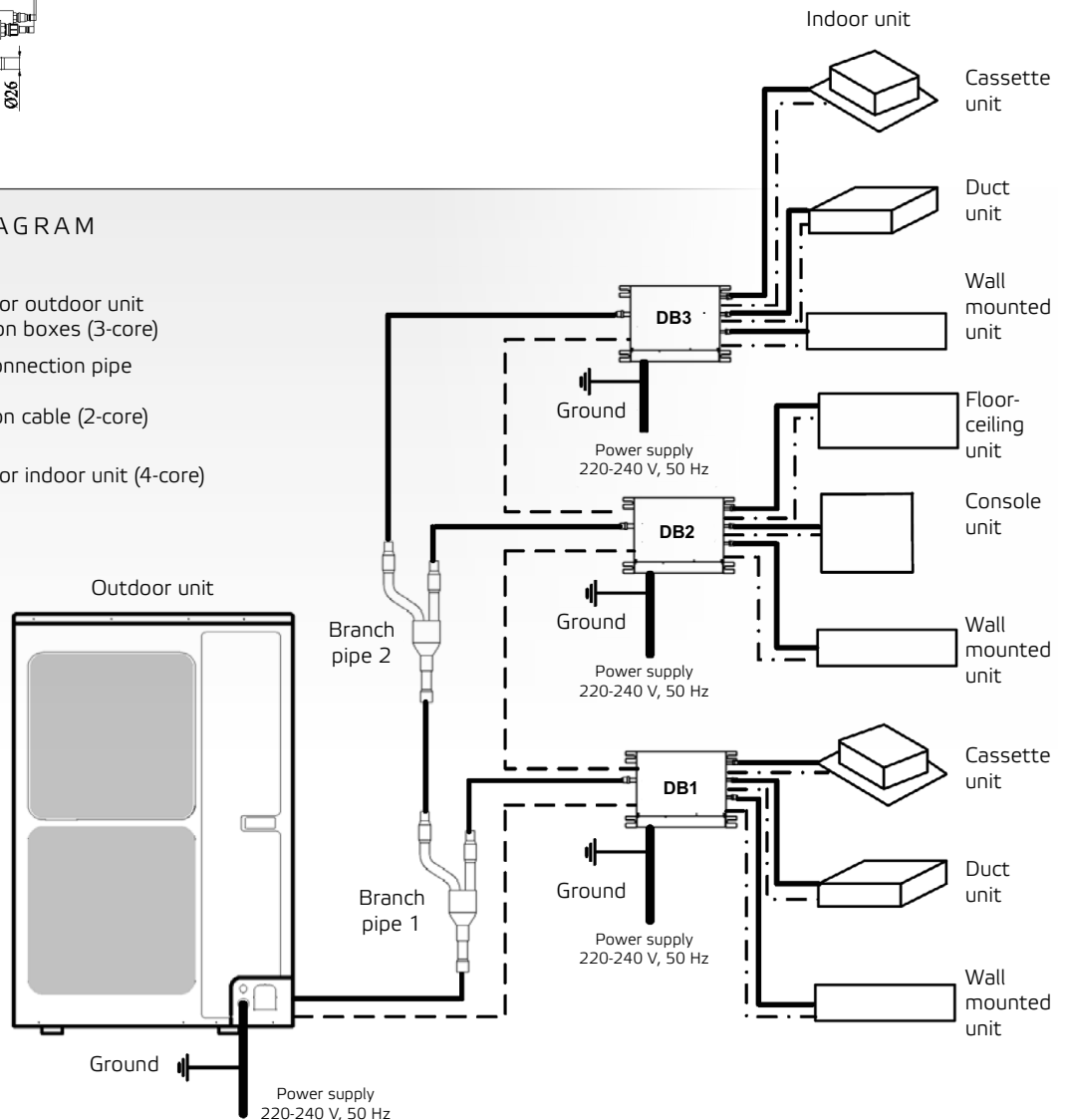

ELECTRICAL WIRING DIAGRAM
HIGH POWER MULTI SYSTEM SERIES

OPTION 1

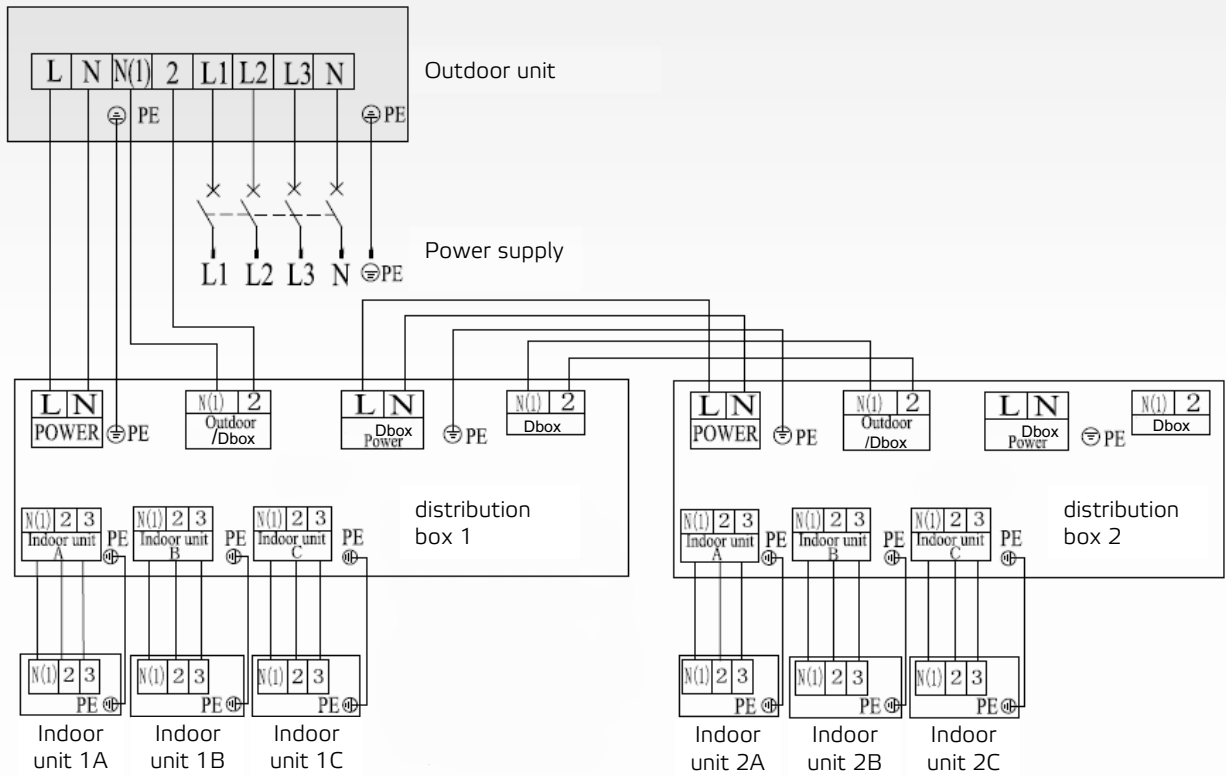

OPTION 2

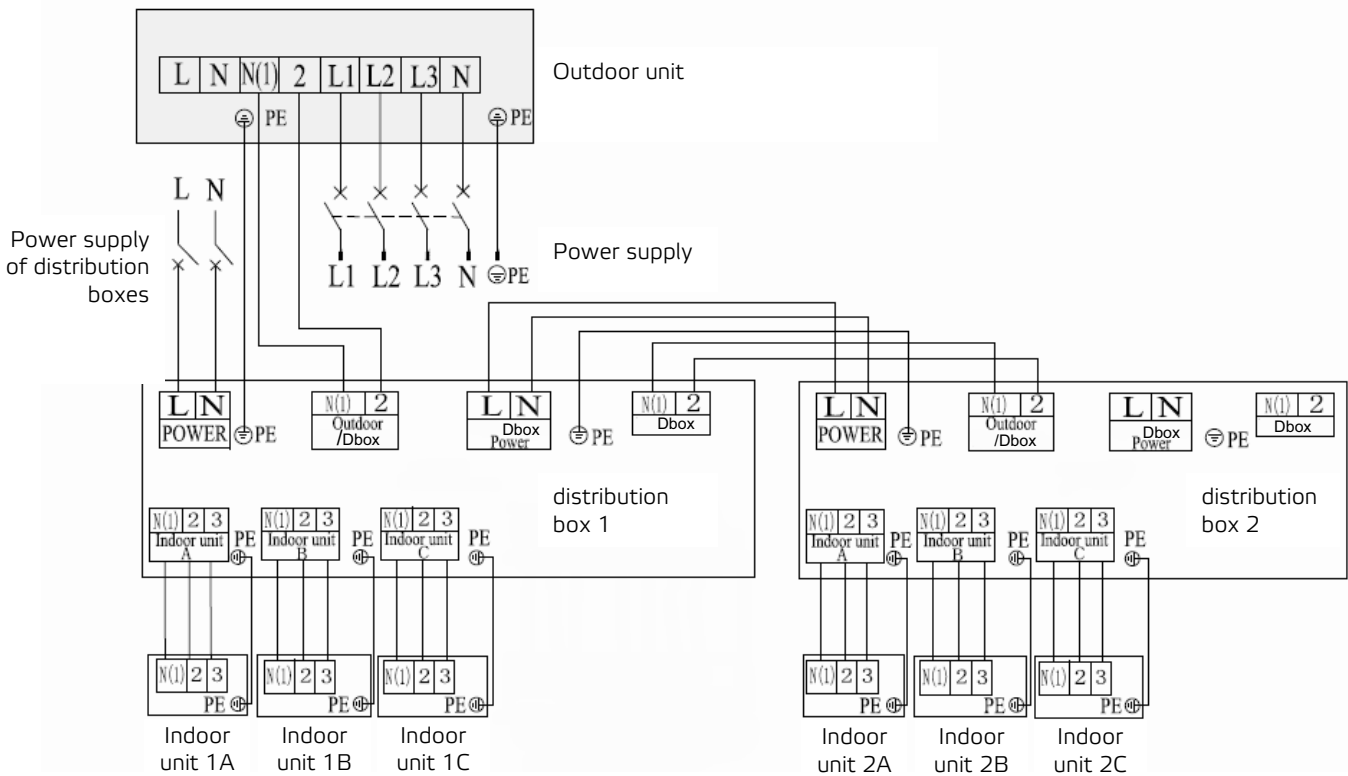

ELECTRICAL WIRING DIAGRAM
HIGH POWER MULTI SYSTEM SERIES

OPTION 3

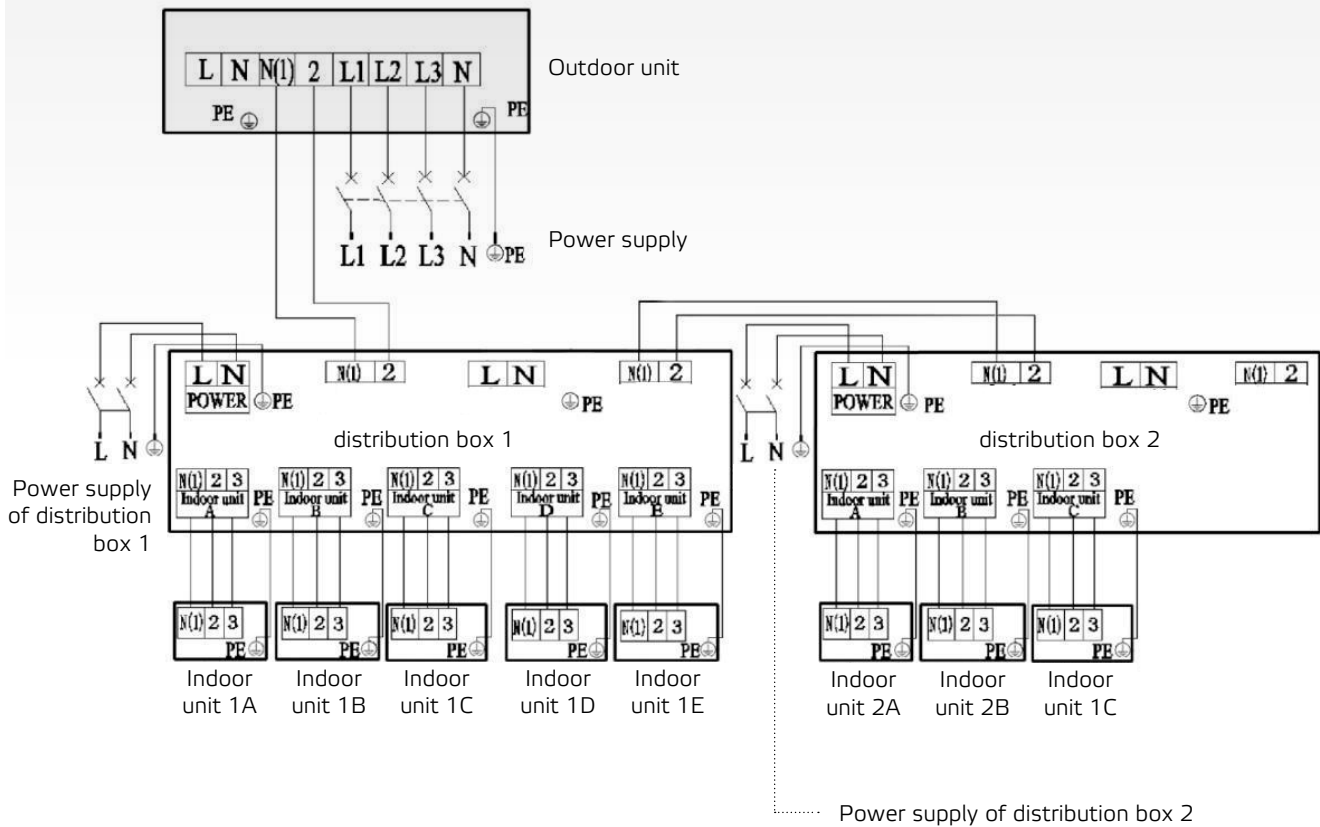

REQUIREMENTS OF POWER CIRCUIT AND CABLE

Frequency		Hz	50
Phase and voltage	Outdoor unit	f, V	3 phases, 380-415
	Distribution box	f, V	1 phase, 220
Recommended cable of outdoor unit (pieces x sectional area)	MS-E48AIN	mm ²	5x4,0
	MS-E56AIN	mm ²	5x4,0
Recommended cable of distribution box (pieces x sectional area)		mm ²	3x1,0
Communication cable (pieces x sectional area)		mm ²	2x1,5
Recommended cable of indoor unit (pieces x sectional area)		mm ²	4x1,0
Capacity of the air switch	MS-E48AIN	A	C20
	MS-E56AIN	A	C20
	Distribution box	A	C10

SPLIT AIR CONDITIONER

HIGH STATIC PRESSURE DUCT UNIT

MODEL		ASDH-96AI				
Capacity cooling/heating 1)	Nominal (min-max)	kW	28,0 / 31,5			
Power supply ID		Hz / V	1~ / 50 / 220-240			
Power supply OD		-	3~ / 50 / 380-415			
Power input cooling/heating 1)		W	9000 / 8500			
Maximal power input 2)		W	11700			
Power current cooling/heating		A	4,5			
Maximal power current 2)		A	16,0			
EER / COP		-	3,11 / 3,71			
Air flow of ID	H/M/L	m³ / h	4800/4100/3000			
Airflow of OD	H	m³ / h	9800			
Sound pressure of ID 4)	min-max	dB(A)	49-52			
Sound pressure of OD 4)	H	dB(A)	59			
Sound power of ID 4)	H/M/L	dB(A)	-			
Sound power of OD 4)	V	dB(A)	-			
External static pressure		Pa	0~150			
Dehumidifying volume		l / h	-			
Refrigerant type/charge		Type / kg / t eq. CO ₂	R410A / 7,2 / 15,03			
Additional refrigerant		g / m	30			
Pipe diameter - liquid side 5)		inch / mm	¾ / 9,5			
Pipe diameter - gas side 5)		inch / mm	1 / 25,4			
Max pipe length without additional refrigerant 6)		m	5			
Maximal allowed pipe length 7)		m	50			
Max. elevation / Drop height*		m	25/30			
Dimension of ID	w x h x d	mm	1470x512x775			
Dimensions of outdoor unit	w x h x d	mm	1120x1558x528			
Package dimension of ID	w x h x d	mm	1555x545x875			
Package dimensions of outdoor unit	w x h x d	mm	1270x1720x565			
Weight of ID	netto / brutto	kg	83 / 92			
Weight of OD	netto / brutto	kg	148 / 164			
Set temperature range		°C	17~30			
Operating temperature range 8)	cooling	°C	-15~48			
	heating	°C	-15~24			
ADDITIONAL TECHNICAL INFORMATION						
Screw holes distance of OD	w (w2) x d	mm	668 (874)x494			
Communication cable		mm²	3x0,75			
Recommended power cable	indoor	mm²	3x2,5			
	outdoor	mm²	5x6			
Recommended air switch	indoor	A	C16			
	outdoor	A	C40			
EQUIPMENT						
Plasma generator	indoor		-			
Wifi module			-			
Drain pump			-			
Max. lift (from bottom of ID unit)		mm	-			
Dry contact (ON/OFF)				✓		
Alarm contact				✓		
Fresh air inlet	outdoor		-			
Throttling method			Capillary			
Bottom chassis heater			-			
Crankcase heater				✓		
Bottom plugs for OD				✓		
Drain pipe connector				✓		
STANDARD ACCESSORIES						
Standard health filter			-			
Remote controller (IR)			-			
Wired controller			KJR-29B1/BK-E			
OPTIONAL ACCESSORIES						
Optional health filters			-			
Wired controller			-			
Central controller			CCM30			

* Outdoor unit above indoor unit / Outdoor unit below indoor unit

The specification of products is subject to change based on further development of the units by the producer and can be changed without prior notice. Refer to rating label.

R410A (50% HFC-32, 50% HFC-125), GWP 2088

Contains fluorinated greenhouse gases covered by the Kyoto Protocol.

Explanatory notes on the very last page of the catalogue.

The device is being sold as a set (indoor + outdoor unit).

APPEARANCE AND DIMENSIONS OF UNITS
HIGH STATIC PRESSURE DUCT UNIT

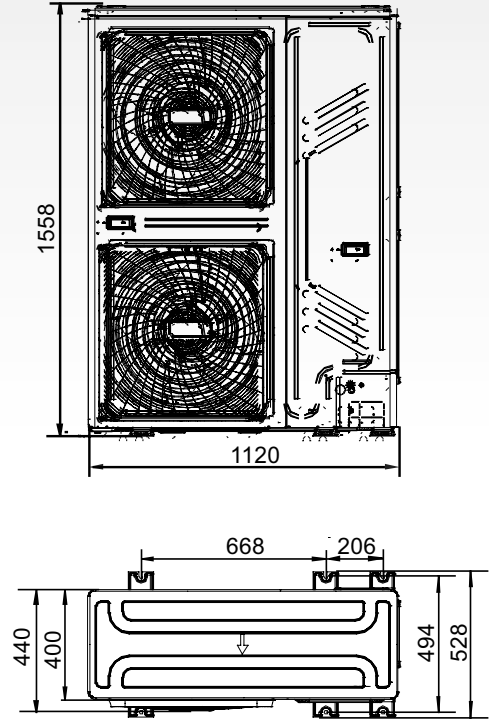
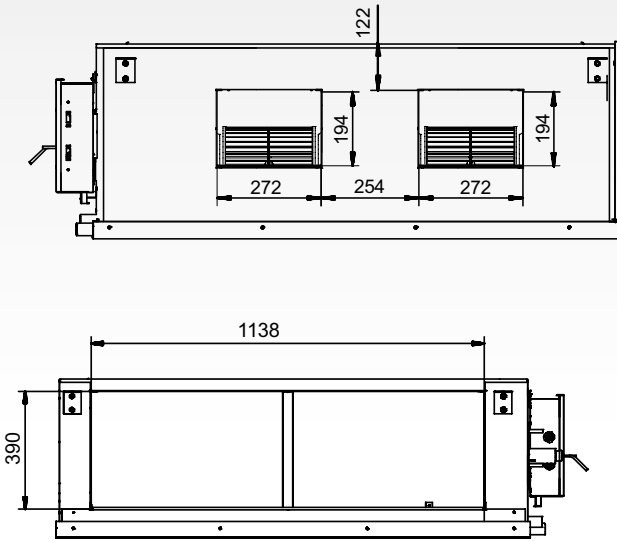

units: mm

ELECTRICAL WIRING DIAGRAM

POWER SUPPLY 380-415V ~50HZ

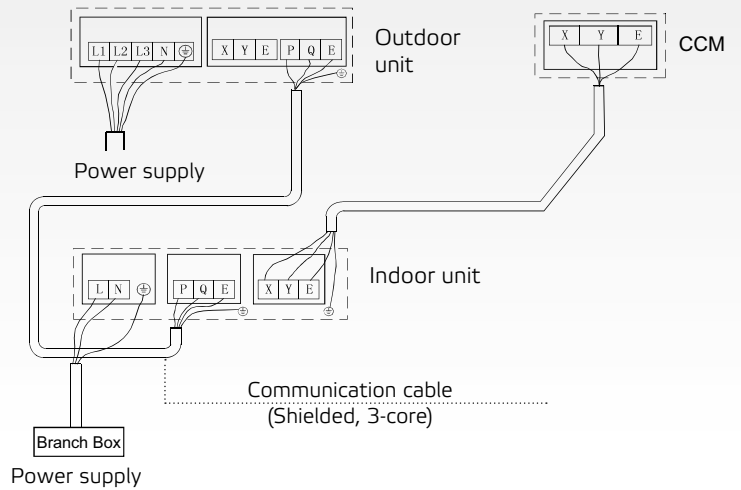
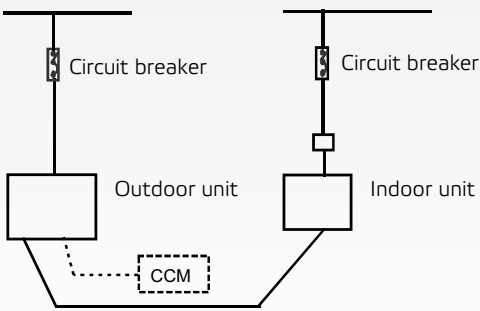

WINDOW MONOBLOCK AIR CONDITIONERS

WINDOW SERIES

MODEL			ASW-09BI	ASW-12BI		
Cooling capacity 1)	Nominal	kW	2,7	3,7		
Power supply	Frequency/Voltage	Hz / V	1~ / 50 / 220-240	1~ / 50 / 220-240		
Application area		m ²	12-18	16-24		
Power input cooling 1)		W	782	1030		
Maximal power input 2)		W	1100	1300		
Power current cooling		A	3,5	4,6		
Maximal power current 2)		A	5,5	6,5		
SEER		-	3,45	3,54		
Energy class cooling		-	A	A		
Air flow of ID	H/M/L	m ³ /h	400/360/320	480/430/380		
Airflow of OD	H	m ³ /h	800	1200		
Sound pressure of ID 4)	H/M/L	dB(A)	50/48/46	50/48/46		
Sound pressure of OD 4)	H	dB(A)	56/54/52	58/56/54		
Sound power of ID 4)	H/M/L	dB(A)	59/57/55	59/57/55		
Sound power of OD 4)	H	dB(A)	65/63/61	65/63/61		
Dehumidifying volume		l/h	1,0	1,6		
Refrigerant type/charge		Type / kg / t eq.CO ₂	R32 / 0,51 / 0,34	R32 / 0,63 / 0,43		
Dimension	w x h x d	mm	560x375x710	660x428x700		
Package dimension	w x h x d	mm	623x425x806	739x505x793		
Weight	netto / brutto	kg	43,0 / 47,0	50,0 / 54,0		
Set temperature range		°C	16 ~ 30	16 ~ 30		
Operating temperature range cooling 8)		°C	16 ~ 43	16 ~ 43		
STANDARD ACCESSORIES						
Standard health filter			-	-		
Remote controller (IR)			YX1F	YX1F		
Wired controller			-	-		
OPTIONAL ACCESSORIES						
Optional health filters			-	-		
Wired controller			-	-		
Central controller			-	-		

The specification of products is subject to change based on further development of the units by the producer and can be changed without prior notice. Refer to rating label.

R32 (single component refrigerant HFC), GWP of refrigerant used: 675.

Contains fluorinated greenhouse gases covered by the Kyoto Protocol.

Hermetically sealed system.

Explanatory notes on the very last page of the catalogue.

APPEARANCE AND DIMENSIONS OF UNITS

ASW-09BI

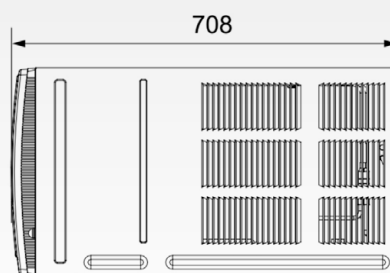
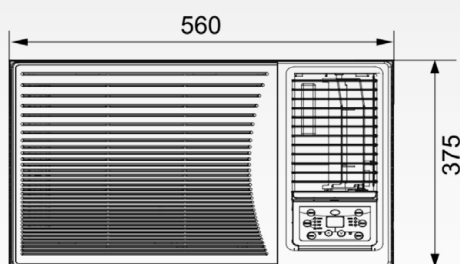

ASW-12BI

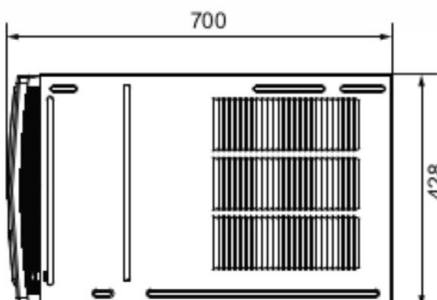
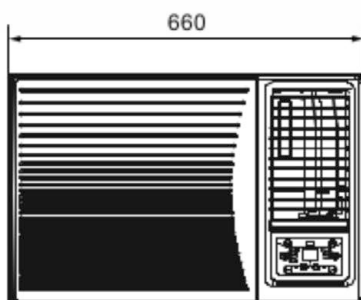

units: mm

SPLIT AIR CONDITIONER

TOWER SERIES

MODEL	AST-24AI		
Capacity cooling/heating 1)	Nominal (min-max)	kW	7,2 / 7,5
Power supply 1)	Frequency/Voltage	Hz / V	1~ / 50 / 220-240
Optimal room area		m ²	27-42
Power input cooling/heating 1)		W	2250 / 2080
Maximal power input 2)		W	3800
Power current cooling/heating		A	10,4/9,3
Maximal power current 2)		A	18
Energy class cooling 3)		-	A++
Pdesign cooling		kW	7,2
SEER		-	6,1
Annual power consumption		kWh / annum	413
Energy class heating 3)	Average climate	-	A+
Pdesign heating	Average climate	kW	6,1
SCOP	Average climate	-	4,0
Annual power consumption	Average climate	kWh / annum	2135
Air flow of ID ID	SH/H/M/L	m ³ / h	1400/1150/1050/900
Air flow of ID OD	H	m ³ / h	3200
Sound pressure of ID 4)	SH/H/M/L	dB(A)	49/45/42/39
Sound pressure of OD 4)	H	dB(A)	60
Sound power of ID 4)	SH/H/M/L	dB(A)	63/57/53/50
Sound power of OD 4)	H	dB(A)	70
Dehumidifying volume		l / h	2,0
Refrigerant type/charge	Type / kg / t eq.CO ₂		R410A / 2,0 / 4,18
Additional refrigerant		g / m	50
Pipe diameter - liquid side 5)		inch / mm	¼ / 6,4
Pipe diameter - gas side 5)		inch / mm	¾ / 15,9
Max pipe length without additional refrigerant 6)		m	5
Maximal allowed pipe length 7)		m	25
Max. elevation/ Drop height		m	10
Dimension of ID	w x h x d	mm	507x1771x320
Dimensions of outdoor unit	w x h x d	mm	955x700x396
Package dimension of ID	w x h x d	mm	1988x623x440
Package dimensions of outdoor unit	w x h x d	mm	1029x458x750
Weight of ID	netto / brutto	kg	40,0 / 54,0
Weight of OD	netto / brutto	kg	53,5 / 58,0
Set temperature range		°C	16-30
Operating temperature range 8)	cooling	°C	-15-43
	heating	°C	-15-24

ADDITIONAL TECHNICAL INFORMATION

Screw holes distance of OD	w x d	mm	560x364
Communication cable		mm ²	4x1,5
Recommended power cable		mm ²	3x2,5
Recommended air switch		A	25

EQUIPMENT

Plasma generator	indoor		-
Wifi module			✓
Drain pump			-
Max. lift (from bottom of ID unit)		mm	-
Dry contact (ON/OFF)	outdoor		-
Alarm contact			-
Fresh air inlet			-
Throttling method			EXV
Bottom chassis heater			-
Crankcase heater			-
Bottom plugs for OD			✓
Drain pipe connector		✓	

STANDARD ACCESSORIES

Standard health filter			-
Remote controller (IR)			YAP1F4(WiFi)
Wired controller			-

OPTIONAL ACCESSORIES

Optional health filters			-
Wired controller			-
Central controller			-

APPEARANCE AND DIMENSIONS OF UNITS

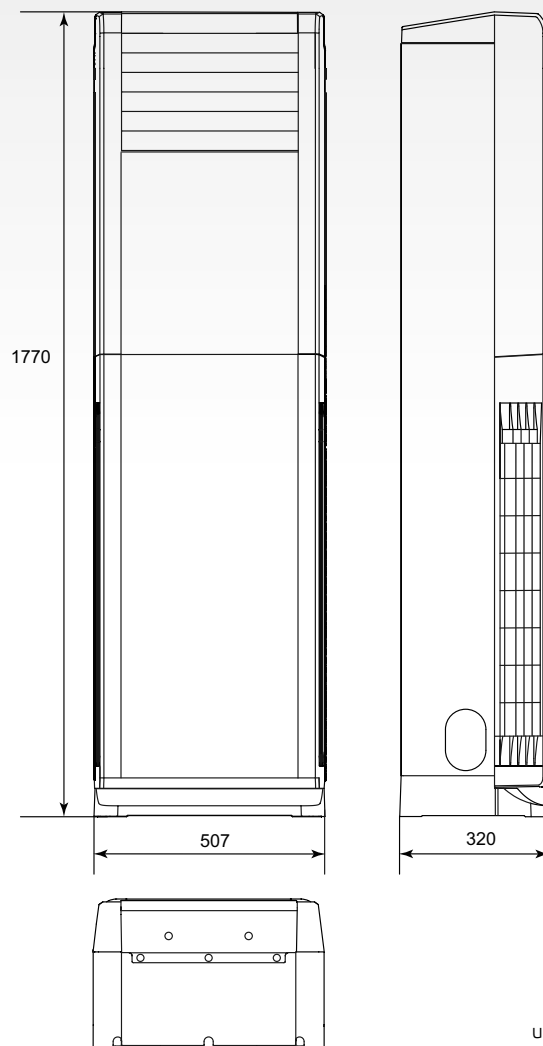

units: mm

APPEARANCE AND DIMENSIONS OF UNITS

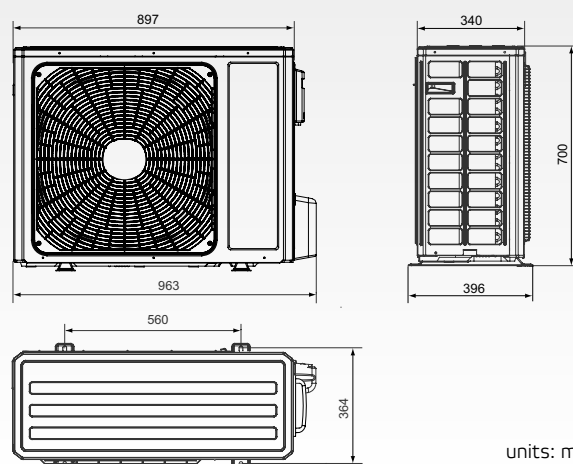

units: mm

ELECTRICAL WIRING DIAGRAM

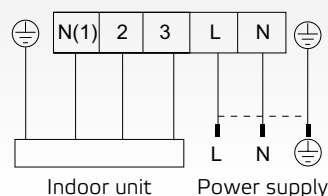

VEHICLE AIR CONDITIONERS

CAMPER TRAILER AIR CONDITIONER

MODEL			ASV-25AS	ASV-35AS		
Capacity cooling/heating 1)	Nominal (min-max)	kW	2,5 / 2,2	3,5 / 3,2		
Power supply	Frequency/Voltage	Hz / V	1~ / 50 / 220-240	1~ / 50 / 220-240		
Power input cooling/heating 1)		W	1070 / 980	1270 / 1180		
Maximal power input 2)		W	1400	1400		
Power current cooling/heating		A	4,7 / 4,2	4,7 / 4,2		
Maximal power current 2)		A	6,6	6,6		
EER / COP		-	2,34 / 2,24	2,76 / 2,71		
Air flow of ID	SH/H/M/L	m³ / h	340 / 280 / 220 / 190	380 / 320 / 260 / 230		
Airflow of OD	H/L	m³ / h	600 / 300	600 / 300		
Sound pressure of ID 4)	SH/H/M/L	dB(A)	53 / 48 / 43 / 38	55 / 49 / 44 / 39		
Sound pressure of OD 4)	H/L	dB(A)	65 / 55	65 / 55		
Sound power of ID 4)	SH/H/M/L	dB(A)	63 / 58 / 53 / 48	65 / 59 / 54 / 49		
Sound power of OD 4)	H/L	dB(A)	75 / 65	75 / 65		
Dehumidifying volume		l / h	1,0	1,5		
IP protection		-	IPX4	IPX4		
Roof mounting hole		mm	356x356	356x356		
Roof thickness		mm	30 - 80	30 - 80		
Refrigerant type/charge		Type / kg / t eq.CO ₂	R410A / 0,67 / 1,4	R410A / 0,67 / 1,4		
Dimension of ID	w x h x d	mm	485x49x610	485x49x610		
Dimension of OD	w x h x d	mm	1018x259x650	1018x259x650		
Package dimension of ID	w x h x d	mm	547x109x668	547x109x668		
Package dimension of OD	w x h x d	mm	1099x312x715	1099x312x715		
Weight of ID	netto / brutto	kg	2,7 / 4,0	2,7 / 4,0		
Weight of OD	netto / brutto	kg	42,5 / 49,0	42,5 / 49,0		
Set temperature range		°C	16 ~ 30	16 ~ 30		
Operating temperature range 8)	cooling	°C	18 ~ 43	18 ~ 43		
	heating	°C	2 ~ 24	2 ~ 24		
EQUIPMENT						
Plasma generator	indoor		-	-		
Wifi module			✓	✓		
Drain pump			-	-		
Max. lift (from bottom of ID unit)		mm	-	-		
Dry contact (ON/OFF)	outdoor		-	-		
Alarm contact			-	-		
Fresh air inlet			-	-		
Throttling method			Capillary	Capillary		
Bottom chassis heater			-	-		
Crankcase heater			-	-		
Bottom plugs for OD			-	-		
Drain pipe connector			-	-		
STANDARD ACCESSORIES						
Standard health filter			-	-		
Remote controller (IR)			YAM1F1	YAM1F1		
Wired controller			-	-		
OPTIONAL ACCESSORIES						
Optional health filters			-	-		
Wired controller			-	-		
Adapter			ASV-PA	ASV-PA		

The specification of products is subject to change based on further development of the units by the producer and can be changed without prior notice. Refer to rating label.

R410A (50% HFC-32, 50% HFC-125), GWP 2088

Contains fluorinated greenhouse gases covered by the Kyoto Protocol.

Hermetically sealed system.

Explanatory notes on the very last page of the catalogue.

POWER SUPPLY, APPEARANCE AND DIMENSIONS OF UNITS

Indoor unit

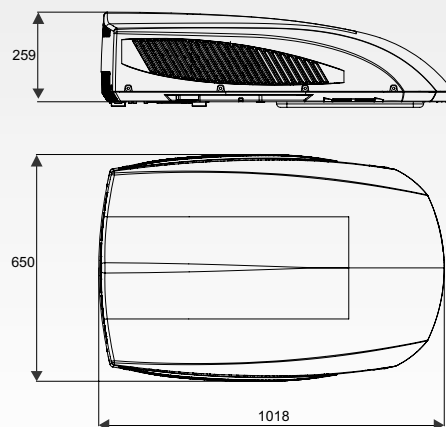
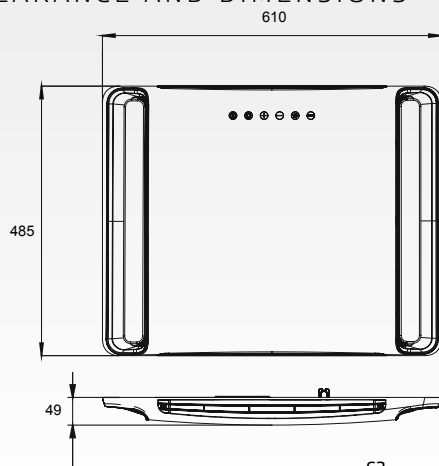
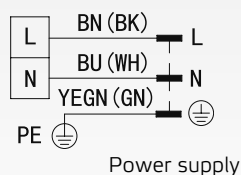

units: mm

WATER-TO-AIR HEAT PUMP

BOAT SERIES

MODEL			ASB-05A	ASB-09A	ASB-12A	ASB-16A	ASB-24A
Capacity cooling/heating 12)	Nominal (min-max)	kW	1,10 / 1,40	2,10 / 2,20	3,10 / 3,20	3,20 / 4,00	6,40 / 6,65
Power supply	Frequency/Voltage	Hz / V	1~ / 50 / 220-240	1~ / 50 / 220-240	1~ / 50 / 220-240	1~ / 50 / 220-240	1~ / 50 / 220-240
Power input cooling/heating 1)		W	560 / 530	900 / 880	1100 / 1100	1200 / 1300	1450 / 1750
Maximal power input 2)		W	800 / 750	1350 / 1100	1600 / 1700	1650 / 1650	2400 / 2700
Power current cooling/heating		A	3,5 / 3,4	4,9 / 4,8	6,1 / 6,0	6,0 / 6,1	6,8 / 8,2
Maximal power current 2)		A	6,2 / 6,1	7,3 / 7,0	9,0 / 9,0	8,2 / 8,6	11,5 / 11,8
EER / COP		-	1,96 / 2,64	2,33 / 2,50	2,82 / 2,91	2,67 / 3,08	4,41 / 3,80
Air flow of ID	H	m ³ / h	320	450	466	590	951
Sound pressure of ID 4)	H	dB(A)	58	58	58	62	60
Sound power of ID 4)	H	dB(A)	68	68	68	72	70
Refrigerant type/charge		Type / kg / t ekv.CO ₂	R410A / 0,32 / 0,67	R410A / 0,34 / 0,71	R410A / 0,53 / 1,11	R410A / 0,46 / 0,96	R410A / 0,95 / 1,98
Dimension of ID	w x h x d	mm	285x408x295	380x408x310	380x420x330	450x465x330	595x529x386
Package dimension of ID	w x h x d	mm	594x493x360	683x513x360	608x533x395	663x558x395	853x638x440
Weight of ID	netto / brutto	kg	25,5 / 30,0	28,0 / 33,0	33,0 / 38,0	37,5 / 43,5	60,5 / 68,0
Set temperature range		°C	16~30	16~30	16~30	16~30	16~30
Operating temperature range cooling 8)		°C	16 ~ 43	16 ~ 43	16 ~ 43	16 ~ 43	16 ~ 43
Operating temperature range heating 8)		°C	-10 ~ 30	-10 ~ 30	-10 ~ 30	-10 ~ 30	-10 ~ 30
Operating temperature range cooling 8)	water	°C	10 ~ 35	10 ~ 35	10 ~ 35	10 ~ 35	10 ~ 35
Operating temperature range heating 8)	water	°C	4 ~ 25	4 ~ 25	4 ~ 25	4 ~ 25	4 ~ 25
STANDARD ACCESSORIES							
Standard health filter					-		
Remote controller (IR)					YX1F		
Wired controller					✓		

The specification of products is subject to change based on further development of the units by the producer and can be changed without prior notice. Refer to rating label.

R410A (50% HFC-32, 50% HFC-125), GWP 2088

Contains fluorinated greenhouse gases covered by the Kyoto Protocol.

Explanatory notes on the very last page of the catalogue.

INSTALLATION OF UNIT

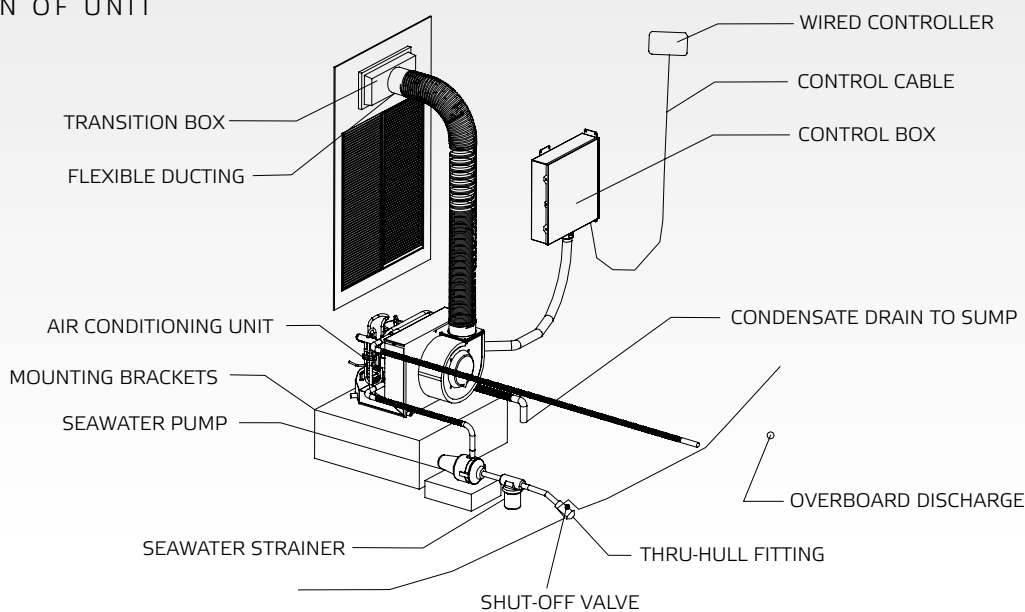

APPEARANCE, DIMENSIONS AND WIRING OF UNITS

BOAT SERIES

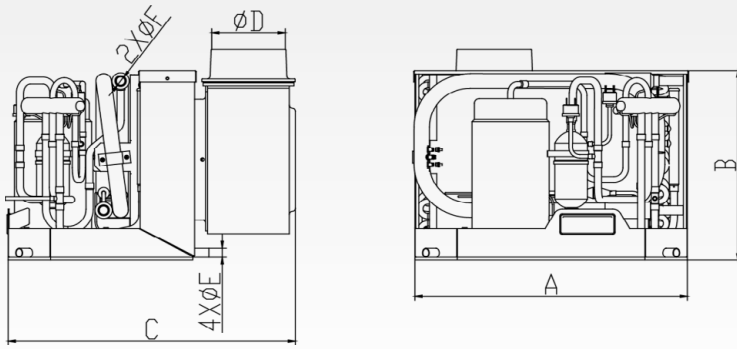

units: mm

	A	B	C	D	E	F
ASB-05A	285	295	408	91,5	16	19
ASB-09A	380	310	408	91,5	16	19
ASB-12A	380	330	420	119,4	16	19
ASB-16A	450	330	465	119,4	16	19
ASB-24A	529	386	595	119,4	16	19

ELECTRICAL WIRING DIAGRAM

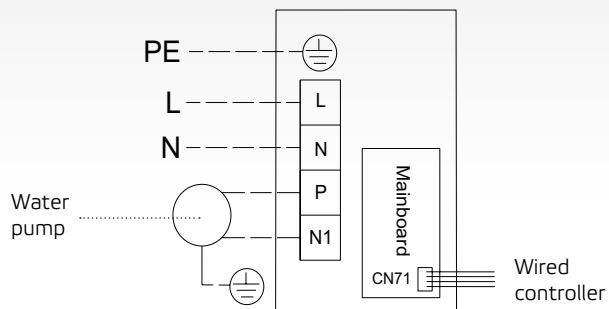

PACKAGE CONTENTS

	Package Include
Wired Controller	✓
Remote Controller	✓
Communication Cable of Wired Controller (8 m)	✓
Power Supply Wire	-
Inlet/Outlet water pipe	-
Fixed board	-
Condensing drain pipe	-
Flexible Ducting	-
Air Diffuser	-
Air Return Grill	-
Water pump	-
Filter	-

LOCAL AIR CONDITIONERS

MODEL			AMC-11P	AMC-14P		
Capacity	Cooling	kW	3,0	4,0		
	Heating	kW	3,0	4,0		
Optimal room size		m ²	15-25	25-35		
Power supply	Frequency/Voltage	Hz / V	1~ / 50 / 220-240	1~ / 50 / 220-240		
Rated current		A	5,5	6,8		
Power input	Cooling/Heating	W	1150/ 965	1535/ 1290		
EER / COP		-	2,6 / 3,1	2,6 / 3,1		
Energy class	Cooling/Heating	-	A / A++	A / A++		
Noise - indoor unit		dB(A)	65	65		
Air flow		m ³ /h	450	450		
Dehumidifying volume		l/day	50	70		
Refrigerant type/ charge		Type / kg	R290 / 0,23	R290 / 0,27		
Dimension (w x h x d)		mm	300x760x532	300x760x532		
Package dimension (w x h x d)		mm	330x855x620	330x855x620		
Net/ gross weight		kg	28,6 / 30,7	30,6 / 32,8		
Operating temperature	Cooling	°C	17-32	17-32		
	Heating	°C	7-25	7-25		

R290 (100% CH3CH2CH3)

APPEARANCE AND DIMENSIONS OF UNITS

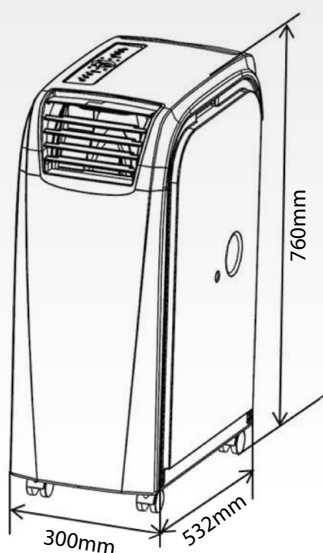

units: mm

ACCESSORIES



AMC-WINK
WINDOW KIT
(standard)

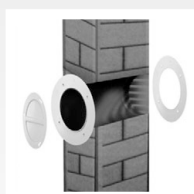

AMC-WK
WALL KIT
(optional)

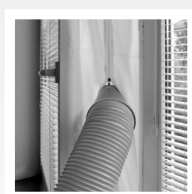

WK-400A
WINDOW KIT
(optional)

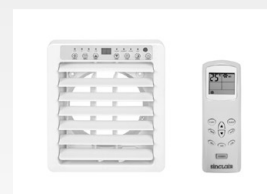

AK-15P
(optional)

MOBILE DEHUMIDIFIERS

MODEL			CFO-16P	CFO-20P	CFO-40P		
Dehumidifying volume		l/day	16,0	20,0	40,0		
Power supply		Hz / V	1~ / 50 / 220-240	1~ / 50 / 220-240	1~ / 50 / 220-240		
Power input / Max. power input		W	220 / 245	360 / 450	670 / 900		
Rated current		A	1,1	2,1	4,0		
Sound pressure level		dB	41 / 38	43 / 41 / 39	48 / 45 / 42		
Air flow		m³/h	115 / 100	130 / 115 / 105	230 / 195 / 170		
Water tank volume		l	2,5	3,5	6,5		
Optimal room size		m²	20	28	48		
Refrigerant type / charge		Type / kg	R290 / 0,085	R290 / 0,11	R290 / 0,15		
Dimension (w x h x d)		mm	305x490x192	363x577x245	396x625x286		
Package dimension (w x h x d)		mm	345x540x230	428x602x311	448x338x638		
Net/ gross weight		kg	10,5 / 11,5	15,5 / 17,0	22,5 / 24,5		
Operating temperature		°C	5 ~ 32	5 ~ 32	5 ~ 32		

R290 (100% CH3CH2CH3)

The values stated in the sheet are complying with norm EN810

Dehumidifying volume is measured according to EN60335-2-40, test conditions: DB 30%, RH 80%

APPEARANCE AND DIMENSIONS OF UNITS

CFO-16P

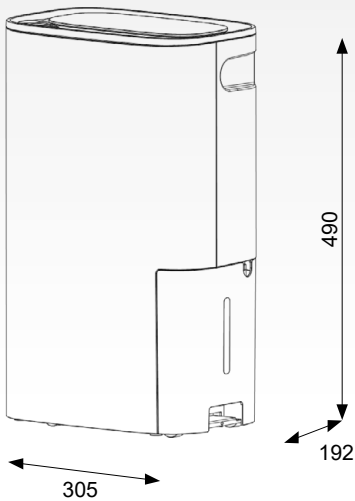

CFO-20P

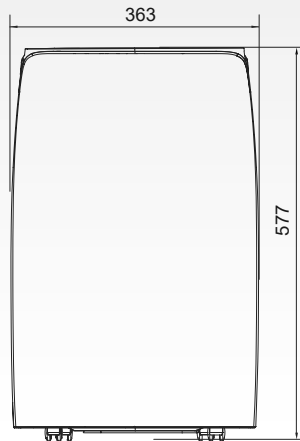

CFO-40P

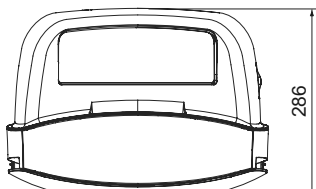
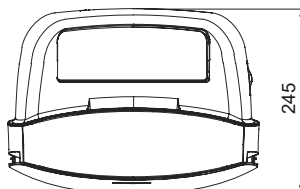
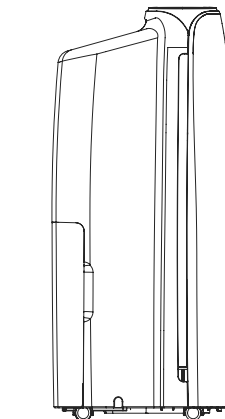
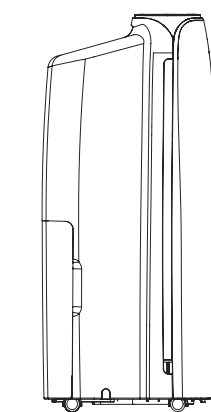
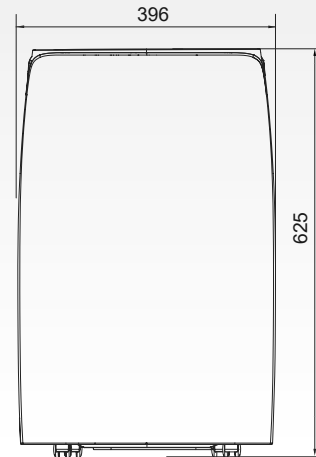

units: mm

PORTABLE DEVICE

AIR PURIFIER

MODEL	SP-45A						
Power supply		Hz / V	1~ / 50 / 220-240				
Power input		W	80				
Rated current		A	0,4				
Sound pressure level at 1m		dB	19 - 51				
Cleaning volume		m ³ /h	340				
Optimal room size		m ²	10-45				
Dimension (w x h x d)		mm	374x594x201				
Package dimension (w x h x d)		mm	433x667x260				
Net / gross weight		kg	6,8 / 8,5				
Operating temperature		°C	0 - 40				

APPEARANCE AND DIMENSIONS OF UNITS

SP-45A



ACCESSORIES

Standard:

- 1 pc HEPA filter
- 1 pc active carbon filter
- 1 pc cotton filter

Optional:

- SPF-45: replaceable dust filters

COMMUNICATION MODULE SCMI-01.4



LOW EVAPORATING TEMPERATURE UP TO -10°C

- SCMI-01.4 offers 3 basic operation modes:
 - Autonomous temperature control mode: The system changes its performance in order to achieve set temperature measured with T2 sensor. You can set temperature from -10°C to +55°C
 - Slave unit mode – operated: You set the compressor performance directly via 0-10V input. Evaporating temperature depends on compressor performance and other conditions
 - Autonomous pressure (evaporating temperature) control mode for cooling only: The compressor performance changes based on evaporating pressure. You can set the pressure which corresponds with temperatures from -10°C to +55°C.
- Control of separate condensing units of UNI SPLIT series
- Direct operation mode (cooling) or reverse operation mode (heating)
- Control of FMD modules
- Password protected setting
- Language options
- Pre-setting of all parameters via USB Communicator software
- DIN rail compatible – 4M wide, installation in power distribution unit
- Also available as SCMI-01.4X version, which widens the goal temperature range from -30°C to +55°C

DEFAULT SETTINGS

Function		Operated	
Goal Temp.	C (cooling)	+10,0°C	
	H (heating)	+25,0°C	
Outputs	Relay 1	Function	On/Off
		Logic	Direct
	Relay 2	Compressor	
	Relay 3	Error	
	DC fan	Off	
Regulation	Time constant	30sec	
	Proportional constant	35	
	Integration constant	0	
	Derivation constant	60	

TECHNICAL PARAMETERS

Power supply	V/Hz	230/50 ±10%
Rated power input	VA	15
Dimension (wxhxd)	mm	90x71x58
Package dimension (wxhxd)	mm	120x100x80
Net/gross weight	kg	0,21 / 0,35
Storage temperature	°C	-25 ~ +70
Operating temperature	°C	-10 ~ +55
Outputs	3x output relays 230/2V	
Inputs	communication input	
	2x input for temperature sensors; input for FMD modules (VE+, VE-)	
	1x voltage input 0-10V, resistance 100kΩ	
	1x current input for pressure sensor 0-18bar	
Standard accessories	2x temperature sensor NTC015WF00 (10kΩ; B=3435)	
Optional accessories	Pressure sensor Alco Controls PT5-18M	

CONDENSING UNITS ASGE-XXBI, ASGE-XXBI-3

- Automatic protection of outdoor unit
- Automatic defrost of outdoor unit
- Informational error display placed on the main board.
- EC fan motor
- Electronic expansion valve as standard accessory
- Connection valves and terminal block on right side
- Compressor heater as standard accessory
- Bottom heater as optional accessory



AUTONOMOUS TEMPERATURE CONTROL MODE FOR COOLING AND HEATING

Performance of the outdoor unit compressor is controlled to keep the temperature set for cooling/heating/ mode combi. The room temperature is measured with the resistance thermometer T2. It is necessary to set the requested temperature for cooling and heating manually. Use "21" and "22" non-potential contacts for switching between cooling and heating mode.

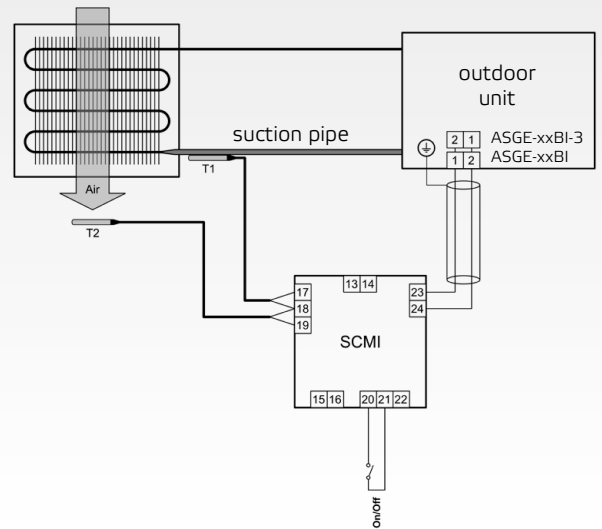
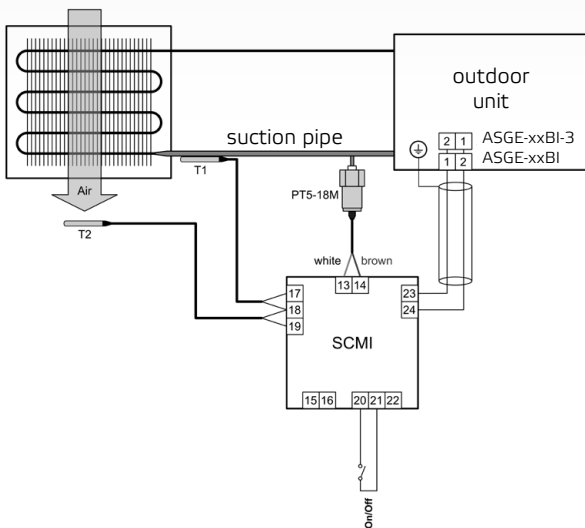

AUTONOMOUS PRESSURE (EVAPORATION TEMPERATURE) CONTROL FOR COOLING

Performance of the outdoor unit compressor is controlled to keep the requested cooling temperature recalculated to appropriate refrigerant (R32) pressure.

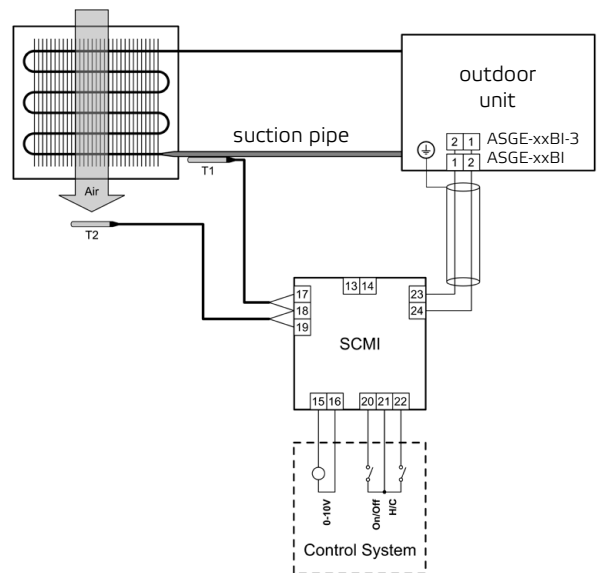

SLAVE UNIT MODE - OPERATED

Performance of the outdoor unit compressor is controlled with SCMI-01.4 module according to direct voltage 0-10V from an external supply. The voltage value corresponds with the desired compressor performance 0-100%. The unit can work in both modes – cooling and heating, H/C connectors are used for switching the modes.

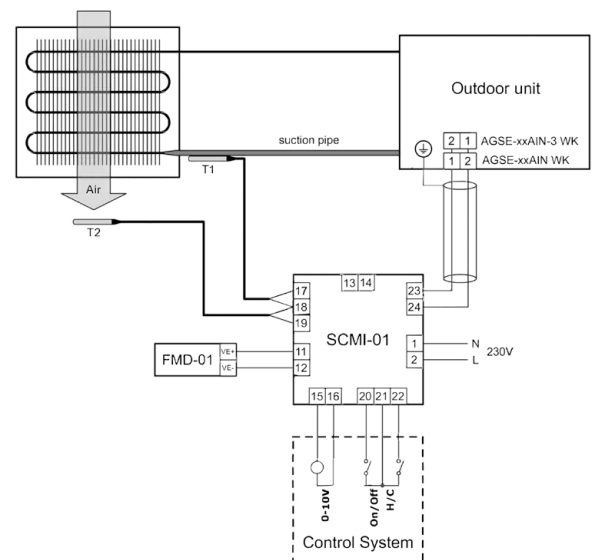

USB COMMUNICATOR

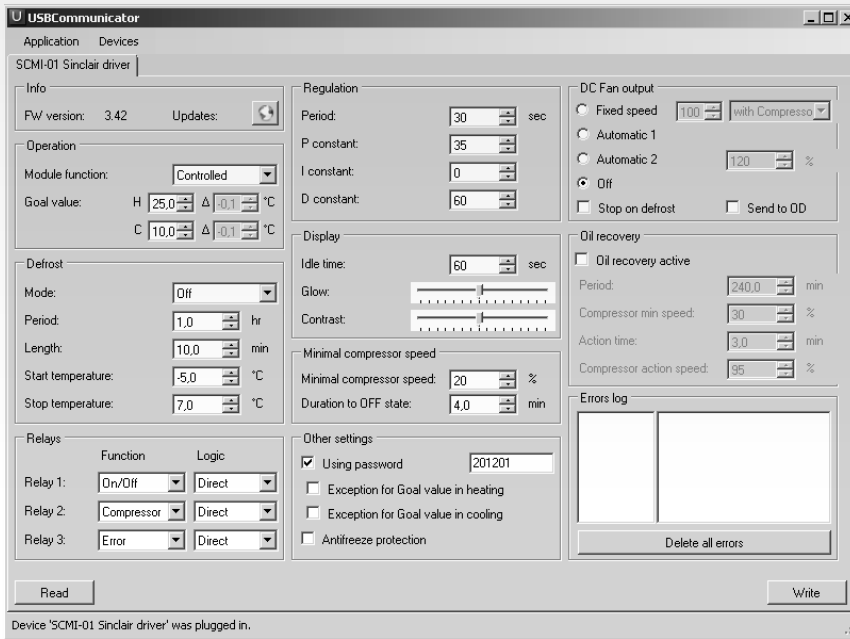

SOFTWARE FOR SCMI-01.4 CONTROL

- Distant setting
- Quick summary of all settings
- Language options (EN, DE, PL, CZ, HU, HR)
- Password setting
- View of error history, history eraser

FMD MODULES

FMD modules are used to control speed of DC fan motors.

FMD-01

Designed to control fan motors of indoor units from UNI SPLIT series*. The fan speed is controlled via SCMI-01.4 module.



* ASD-xxBI, ASC-xxBI, ASF-xxBI except ASD-48BI, ASD-60BI

FMD-01T

Designed to control fan motors of indoor units from UNI SPLIT series*. The fan speed is controlled via multi-turn trimmer.



FMD-03

Designed to control fan motors of indoor units ASD-48BI and ASD-60BI. The fan speed is controlled via SCMI-01.4 module.



OTHER FUNTIONS

SELF-DIAGNOSIS

- Stopping the system when failure has been detected
- Error code displaying on SCMI-01.4
- Automatic defrost

HEALTH FILTERSHEALTH FILTERS FOR RAY, VISION, FOCUS PLUS, SPECTRUM,
SPECTRUM PLUS AND CONSOLE SERIES

SAF-OPWC4

CATECHIN FILTER

Catechin is a green tea extract added to the filters for its oxidizing and sterilizing effects. Active enzymes form a benzene nucleus which absorbs odors and harmful substances in the air. Catechin filter effectively captures and sterilizes dust particles. It is antibacterial and destroys more than 95% of bacteria, e.g., Staphylococcus aureus.

SAF-OPWA4

ACTIVE CARBON FILTER

Active carbon is an excellent absorbent with capability of dual absorption: physical and chemical, as from air and from fluids. Quickly absorbs harmful gases, e.g. benzene, formaldehyde and ammonia.

SAF-OPWB4

BIOLOGICAL FILTER

This filter is made of a material with excellent properties of sterilizing and capture of dust. When air flows through the filter, dust and bacteria are retained on the filter surface, which is bio-bactericidal. In case of attachment of microbes, bio-bactericidal surface disrupts its metabolism and limits its growth. Efficiency of capturing of Escherichia coli and Staphylococcus aureus is higher than 95%.

SAF-OPWS4

SILVER ION FILTER

Silver ion filter is an entirely new kind of powerful sterilizing product. Silver ions are odorless and colorless and have no side effects, such as irritation, pollution or volatility. After sterilization the ions recycle themselves, therefore have a long lifespan and effectively prevent bacterial growth. The filter is also environmentally friendly and completely safe. It is highly efficient and destroys over 99% of the bacteria. Silver ions themselves attract bacteria and microorganisms, pass through the cell membrane and inhibit the cleavage activity of the bacteria. Disrupts DNA structure of bacteria and microorganisms, causing a loss of reproductive ability of bacteria.

SAF-OPWP4

PHOTOCATALYST FILTER

Photocatalytic filter reduces odors and germs via its ultraviolet light. Effectively purifies the air and keeps it fresh. Titan TiO₂ contained in this filter has a strong photocatalytic effect, but it is also environmentally friendly. Removes from the air more than 90% of acetic acid, formaldehyde, ammonia and more than 70% of renewable pollutants.

SAF-OPWK4

COLD CATALYST FILTER

The basic material of the filter are polyurethane (PU) and various catalytic fibers. Effectively captures and removes formaldehyde and other volatile organic compounds (VOCs), as well as harmful gases and odors. The catalyst filter can remove up to 92,9% of formaldehyde from the air within 2,5 hours.

SAF-OPWM4

ANTI-MITE FILTER

Using this filter, you can quickly remove up to 90% of the dust mites from the air. This filter is especially useful for people suffering from allergies and asthma.

WIRED CONTROLLERS

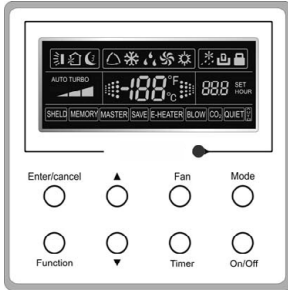

XK19

WIRED CONTROLLER

Standard accessory for duct, cassette and floor-ceiling MULTI VARIABLE units. Optionally can be connected to the indoor units of MULTI VARIABLE, FOCUS, FOCUS PLUS, SPECTRUM, SPECTRUM PLUS, SPLIT CONSOLE series.

It is necessary to order communication cable SC-H01 or SC-CDF for this controller when ordered separately.

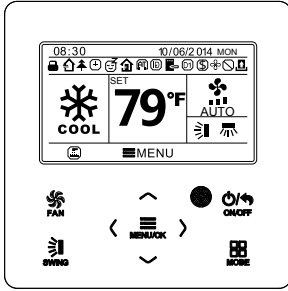

SWC-02

WIRED CONTROLLER

Optional wired controller with weekly timer for the indoor units of MULTI VARIABLE, FOCUS, FOCUS PLUS, SPECTRUM, SPECTRUM PLUS, SPLIT CONSOLE series.

It is necessary to order communication cable SC-H01 or SC-CDF for this controller.



SC-H01

Cable for connection R32 split wall mounted units or MULTI VARIABLE wall mounted, console units or split CONSOLE units with wired controllers XK19 or SWC-02. Length of cable is about 8 meters.



SC-CDF

Cable for connecting MULTI VARIABLE cassette, duct or floor-ceiling indoor units with wired controllers XK19 or SWC-02. Length of cable is about 8 meters.

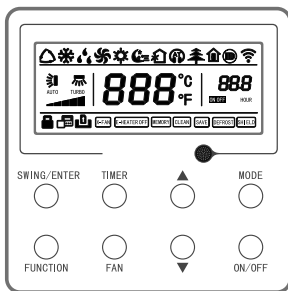

XK117

WIRED CONTROLLER

Standard accessory for indoor units of UNI SPLIT series.

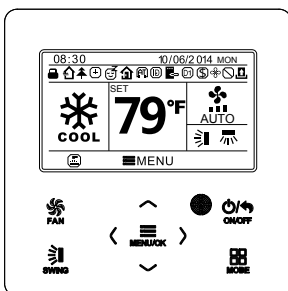

SWC-03

WIRED CONTROLLER

Optional wired controller with weekly timer to the indoor units of UNI SPLIT series.

TECHNICAL PARAMETERS

WIRED CONTROLLERS

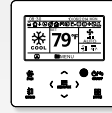
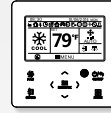

Model	XK19	SWC-02	XK117	SWC-03
On/Off	✓	✓	✓	✓
Mode selection	✓	✓	✓	✓
Temperature setting	✓	✓	✓	✓
Fan control	✓	✓	✓	✓
Swing louver	✓	✓	✓	✓
Save function setting	✓	✓	✓	✓
Room temperature display	✓	✓	✓	✓
Buttons lock	✓	✓	✓	✓
Function lock	✓	✓	✓	✓
On/Off timer	✓	✓	✓	✓
Daily timer	-	✓	-	✓
Weekly schedule timer	-	✓	-	✓
Two week schedule timer	-	✓	-	✓
Auto restart	✓	✓	✓	✓
Turbo mode	✓	✓	✓	✓
Blow (X-fan) mode	✓	✓	✓	✓
Quiet function	-	✓	-	✓
Sleep curve setting	✓	✓	✓	✓
Clock display	-	✓	-	✓
Remote signal receiver	✓	-	✓	-
Clean filter reminder	-	✓	-	✓
Error check function	✓	✓	✓	✓
Unit parameters view	-	✓	-	✓
°F / °C display	-	✓	-	✓
Slave/master controller setting	-	-	✓	-
8°C heating mode	-	-	✓	✓
Low temperature drying mode (12°C)	-	-	✓	✓
Forced defrost mode	✓	✓	✓	✓
Setting (debugging) menu:	Error code history	✓	✓	✓
	Address setting for central controlling	✓	✓	✓
	Ambient temperature sensor setting	✓	✓	✓
	Fans speed level setting	✓	✓	✓
	Antifreeze protection of evaporator (E2) display	-	✓	✓
	Refrigerant leakage protection display	-	✓	✓
	Blow function setting	-	-	✓
	Crankcase heater setting	-	-	✓
	Stand-by power consumption setting	-	-	✓
	On/Off contact activation	-	✓	✓
	External device setting	-	-	✓
	Fan speed setting	-	-	✓
	Temperature compensation setting	-	✓	✓
	AUTO mode selection	-	-	✓
	Defrost mode selection	-	-	✓
Heat pump enabled	✓	-	✓	
Connection	SC-H01 / SC-CDF	SC-H01 / SC-CDF	2-core wire	2-core wire
Dimension	w x h x d	86 x 98 x 39	112 x 112 x 22	86 x 98 x 39
				112 x 112 x 22

CENTRAL CONTROLLERS

SCC-16



CENTRAL CONTROLLER AND WEEKLY TIMER

This central controller allows you to control up to 16 unit simultaneously and set the weekly timer.

It can be used with UNI SPLIT series (has to be connected via modbus gateway SMG-01 – each indoor unit needs to have one SMG-01) or when connected via wired controller SWC-02 or XK19 and communication cable SCC-16k it can be used with MULTI VARIABLE series, R32 wall mounted split units or split CONSOLE series (each indoor unit needs to have one SWC-02 or XK19 and N + 1 pcs of communication cables SCC-16k, where N is number of indoor units).

SCC-16K



COMMUNICATION CABLE FOR SCC-16 CENTRAL CONTROLLER

Used to connect the indoor units to SCC-16 central controller

Necessary number of cables = number of indoor units + 1 pc (if connected to MULTI VARIABLE or R32 wall mounted or split CONSOLE) or 1pc (when connected to UNI SPLIT series).

CONNECTING SCHEMAS

Central controller SCC-16 with UNI SPLIT series

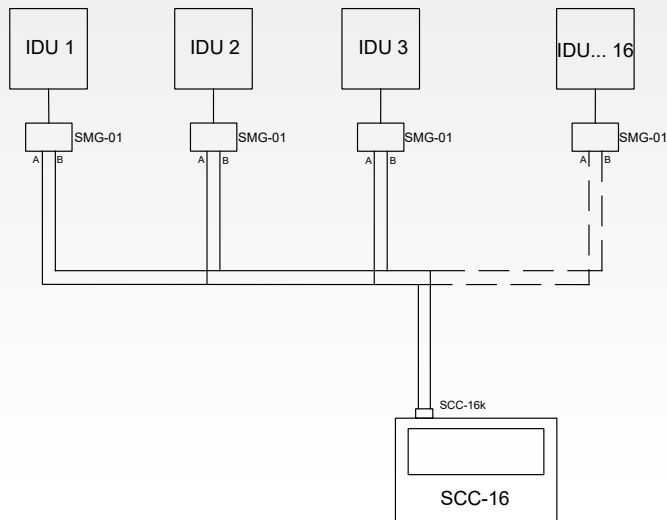

Central controller SCC-16 with multi variable, R32 wall mounted or split console series

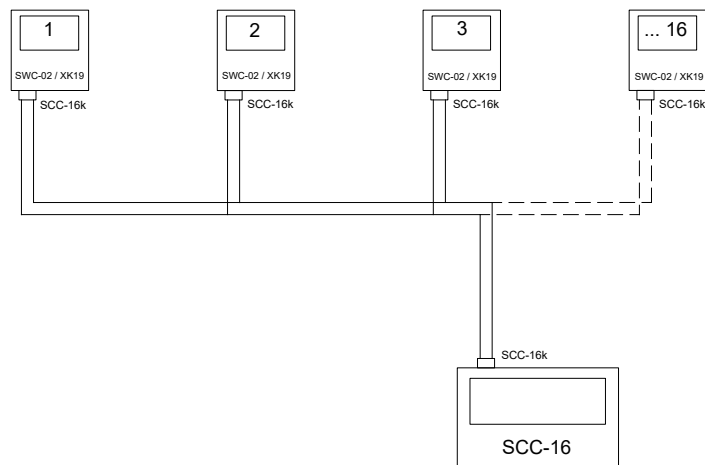

CENTRAL CONTROLLERS

SCC-36



CENTRAL CONTROLLER AND WEEKLY TIMER

- Stylish central controller with 7" touch screen
- Connects up to 36 indoor units
- User friendly interface
- Weekly timer
- Single, group or all units control

It can be used with UNI SPLIT series (has to be connected via Modbus gateway SMG-01 – each indoor unit has to have one SMG-01) or when connected via wired controller SWC-02 and communication cable SCC-36k it can be used with MULTI VARIABLE series, R32 wall mounted split units or split CONSOLE series (each indoor unit has to have one SWC-02 and two SCC-36k).

SCC-36K



COMMUNICATION CABLE FOR CENTRAL CONTROLLER SCC-36

Used for connection of indoor units with central controller SCC-36 and wired controller SWC-02 (for MULTI VARIABLE series, R32 wall mounted units or split Console series).

Order in amount 2N-1 where N is number of indoor units.

CONNECTING SCHEMAS

Central controller SCC-36 with UNI SPLIT series

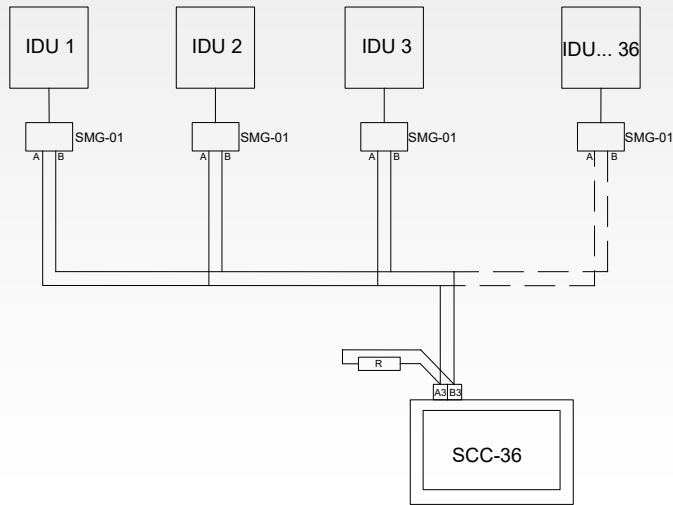

Central controller SCC-36 with multi variable, R32 wall mounted or split console series

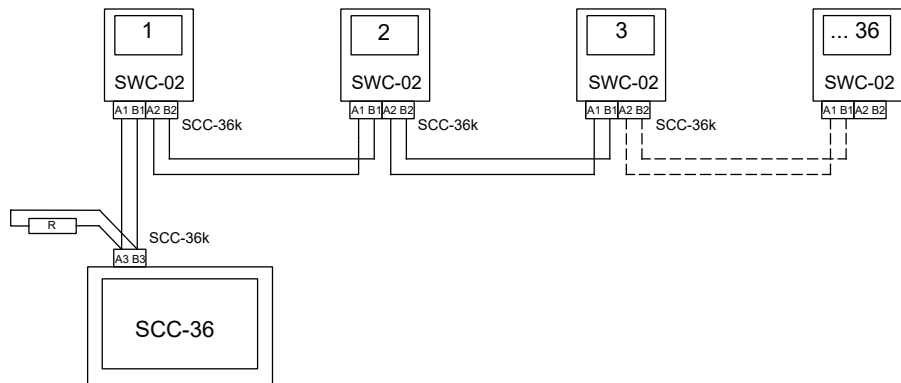

OTHER ACCESSORIES

SWM-03



SINCLAIR WIFI MODULE FOR UNI SPLIT SERIES

WiFi module can be connected to indoor unit to achieve long distance control with smart phone or tablet. SWM-03 is optional accessory for UNI SPLIT units.

SMG-01



MODBUS GATEWAY FOR UNI SPLIT SERIES

Enables the communication of indoor units of UNI SPLIT series via the Modbus protocol. It can be used for connecting SCC-36 central controller or for connection of external control system using Modbus protocol. Control software is not included, it has to be field supplied.

G2S



SINCLAIR MODUL GSM

GSM module is used for controlling SINCLAIR air-conditioners by means of your mobile phone. It applies IR transfer for communication with the air-conditioner, therefore there is no need to connect it to the air-conditioner in any way. In this view it operates as another remote controller. The module is equipped with two transmitting IR diodes, signaling diodes, slot for inserting SIM card and with connectors for connecting power supply cable and for connecting to the USB port of a computer.

SDG-01



SINCLAIR DRY CONTACT GATEWAY

Dry contact gateway allows to externally turn the unit on or off and switch its modes. Module is also equipped with more functions like signaling of malfunction, etc.

G2S-T



G2S-T MODULE

G2S-T module is used for remote monitoring of room temperature. When the set temperature is exceeded, the module sends an information to user's mobile phone. Hence the module has to be equipped with a mini SIM card in order to secure the operation. G2S-T is a stand-alone device, there is no connection between the module and the air conditioner itself. Therefore you can use our G2S-T module for all kinds of applications involving installations with devices of another brands.

SAI-01



ALARM INTERFACE

The SAI-01 SINCLAIR Alarm Interface is an external, separately powered module, which can be connected to the communication line of wall-mounted air conditioner to indicate the operational or malfunction status of the A/C.

SYSTEM ERROR DIAGNOSTICS

SDT-ASH

DIAGNOSTIC TOOL FOR SPLIT WALL MOUNTED AC

- Indoor and outdoor unit diagnostic
- Running parameters
- Simulation run of indoor or outdoor unit
- Test of indoor and outdoor mainboard during communication malfunction
- IR receiver (can be used during outdoor unit's test run)
- User friendly (just 4 buttons)
- Simple display (4 lines)
- No need for other accessories
- Connected to terminal board of units

SDT-MV

DIAGNOSTIC TOOL FOR MULTI SPLIT AC

- Compatible with Multi Variable, Multi System and High Power Multi System series
- Automatic detection of connected units
- User friendly interface
- Running parameters of whole system
- Connected to outdoor unit's mainboard
- 3 diodes (power supply, running, error)
- Power supply: USB connector (cable is included in the package, 5V adapter is field supplied)

TECHHELP

SINCLAIR TECHHELP APP

- This practical tool is used for identification of error codes and their brief analysis.
- List of our products and their error codes, brief description of each error and suggested solution together with possible causes.
- Search comfortably by error code or device name
- Save the already installed devices between "My Devices" and have relevant information about errors available immediately



The app is available at below mentioned web page. Login is required, please use following user name and password. Installing of an application requires permission to install applications from unknown sources.

EN	User name: SinclairTechHelp.en	
	Password: TechHelp1	
DE	User name: SinclairTechHelp.de	
	Password: TechHelp1	
HU	User name: SinclairTechHelp.hu	
	Password: TechHelp1	
PL	User name: SinclairTechHelp.pl	
	Password: TechHelp1	



For downloading of Sinclair tech Help application use the App Store and the following password:

EN	Password: 100285	

GENERAL OVERVIEW OF ERROR CODES

APPLIES TO ALL RESIDENTIAL AIR CONDITIONING UNITS MENTIONED IN THIS CATALOGUE EXCEPT ASDH-96AI

ERROR		Others	
E0	Start-up protection to adjust the frequency when the power input is low	AL	X-fan
E1	High pressure protection	C5	Malfunction of jumper cap
E2	Freeze protection	C6	Ground wire missing
E3	Low pressure protection, refrigerant lacking protection	CC	Wrong wired controller/locked buttons
E4	Compressor high discharge temperature protection	CP	Protection from cold air blowing
E5	Overcurrent protection of the complete unit	EE	Malfunction of outdoor main control memory chip
E6	Communication malfunction	ee	Malfunction of outdoor drive module memory chip
E7	Mode conflict	EU	Limit/decrease frequency due to module temperature protection
E8	Malfunction of indoor fan motor	H0	Decrease frequency for high temperature resistant in heating mode
E9	Full water protection	H1	Defrosting
Failure		H2	Electrostatic dedust protection
F0	Indoor ambient temperature sensor or indoor pipe temperature sensor is open/short circuited	H3	Overload protection of compressor
F1	Indoor ambient temperature sensor is open/short circuited	H4	Overload protection
F2	Indoor evaporator temperature sensor is open/short circuited	H5	IPM protection (module current protection)
F3	Outdoor ambient temperature sensor is open/short circuited	H6	Malfunction of indoor fan motor
F4	Outdoor condenser temperature sensor is open/short circuited	H7	Desynchronizing of compressor
F5	Outdoor discharge temperature sensor is open/short circuited	H8	Water overflow protection
F7	Oil return cycle	Hc	PFC protection
F8	Limit/decrease frequency due to current protection of the complete unit	HE	Demagnetizing protection of compressor
F9	Decrease frequency due to high air discharge	Hp	Evaporator temperature is higher than 58°C (heating mode)
FA	Limit/decrease frequency due to high evaporator or condenser temperature	JF	Malfunction of Wi-Fi module
FH	Limit/decrease frequency due to freeze protection	L3	Malfunction of ODU DC fan motor
F0	Refrigerant lacking/system blockage protection	L9	Power input protection
Fo	Gathering refrigerant	Lp	Indoor unit and outdoor unit do not match
Protection		U1	Malfunction of phase current circuit detection for compressor
P0	Drive module reset protection	Ld	Compressor phase lack protection
P5	Overcurrent protection of compressor	U3	Malfunction of voltage dropping of DC bus-bar
P6	Communication malfunction between main control and drive	U4	Compressor is reversing
P7	Malfunction of module temperature sensor circuit	U5	Malfunction of complete unit's current detection
P8	Module high temperature protection	U6	High temperature protection of oil
P9	Zero-crossing protection	U7	The 4-way valve is abnormal
PL	Voltage of DC bus-bar is too low		
PH	Voltage of DC bus-bar is too high		
PU	Charging malfunction of capacitor		
PP	Input voltage is abnormal		

GENERAL OVERVIEW OF ERROR CODES

E1	Phase sequence error	P0	Top high temperature protection of inverter compressor
E2	Indoor & outdoor unit communication error	P1	High pressure protection or high temperature protection of discharge sensor
E4	Ambient temperature T4/pipe temperature T3 sensor error	P2	Low pressure protection
E5	Voltage error	P3	Outdoor input current protection
E6	DC fan motor fault	P4	Compressor discharge temperature protection
E7	Discharge sensor error	P5	Pipe temperature protection
EA	A fan in the A region run for more than 5 minutes in HEAT mode	P6	Inverter module protection
Eb	2 times of E6 protection in 10 minutes	P8	Storm protection
E8	Outdoor unit address is wrong	PE	Evaporator high temperature protection
E9	EEPROM error	P9	DC fan module protection
H0	IR341 and main control chip communication error	L0	Inverter module error
H1	Communication chip and main control chip communication error	L1	DC generatrix low voltage error
H4	Three times P6 protection in 60 minutes	L2	DC generatrix high voltage error
H5	Three times P2 protection in 60 minutes	L4	MCE error/ synchronization/ closed loop
H6	Three times P4 protection in 100 minutes	L5	Zero speed protection
H7	The number of indoor units decreases	L7	Phase sequence error
H8	High pressure sensor error	L8	Frequency protection - frequency difference in one second more than 15Hz
H9	Three times P9 protection in 60 minutes	L9	Frequency protection - frequency difference between the real and the setting frequency more than 15Hz
HF	M-HOME for the indoor and outdoor units does not match		

GENERAL OVERVIEW OF ERROR CODES

Module SCMI-01.4 error	
Error T1 open	Open circuit of temperature sensor T1
Error T2 open	Open circuit of temperature sensor T2
Error T1 short	Short circuit of temperature sensor T1
Error T2 short	Short circuit of temperature sensor T2
Error P open	Open circuit of pressure sensor P
Error P short	Short circuit of pressure sensor P
Error P low	Low pressure on suction side of compressor
Err. com disconnected	Communication malfunction between SCMI-01.4 module and outdoor unit
Error of UNI SPLIT series outdoor unit	
01000000	E4 - Compressor discharge high-temperature protection
02000000	Lack of refrigerant protection
04000000	Fan DC motor protection
08000000	4-way valve protection
10000000	Overcurrent protection
20000000	H3 - Overload protection
40000000	E3 - Compressor low pressure protection
80000000	E1 - Compressor high pressure protection
00010000	Indoor unit freezing protection
00020000	F3 - Indoor unit freezing protection
00040000	F4 - Discharge temperature sensor malfunction
00080000	F2 - Condenser temperature sensor malfunction
00100000	Condenser inlet tube temperature sensor malfunction
00200000	C5 - Invalid power code (invalid position of the jumper)
00400000	Drive unit memory chip malfunction
00000100	Protection against starting compressor at a low frequency at a low voltage
00000200	DC Bus overvoltage protection
00000400	AC current protection
00000800	IPM protection
00001000	PFC protection
00002000	Start up malfunction
00004000	Compressor wrong phase order protection
00008000	Drive unit module sensor malfunction
00000001	Compressor overcurrent protection
00000002	Power supply protection
00000004	Circuit current measurement malfunction
00000008	H7 - Compressor desynchronization protection
00000010	Compressor stalling protection
00000040	Drive unit module high-temperature protection
00000080	Drive unit module sensor malfunction

EXPLANATORY NOTES:

- Data are based on following conditions: Length of connection pipe: 5m. Cooling: indoor temperature 27°C DB/19°C WB, outdoor temperature 35°C DB/24°C WB. Heating condition: indoor temperature 20°C DB/15°C WB, outdoor temperature 7°C DB/6°C WB.
- Data are based on following conditions: Length of connection pipe: 5m. Cooling: indoor temperature 27°C DB/19°C WB, outdoor temperature 35°C DB/24°C WB. Heating condition: indoor temperature 20°C DB/15°C WB, outdoor temperature 7°C DB/6°C WB.
- SEER/SCOP was calculated according to European standards contained in EN14825, based on part load classifying and testing conditions given by norm EN14511. Energy label can be downloaded from Sinclair product web page after B2B login.
- Noise is tested in the semi-anechoic room, so it should be slightly higher in the actual Operation due to environmental change.
- Cooling mode
- Standard length of liquid pipes pre-filled with refrigerant.
- Maximum length of liquid pipes in one-way including elevation between indoor and outdoor unit.
- Guaranteed range of operational temperatures.
- Maximum length of liquid pipes to last indoor unit.
- EER/COP in accordance with EN14511.
- If the outdoor unit is power supplied, the cable between indoor unit and outdoor unit is also common for communication.
- Data are based on following conditions: Cooling: indoor temperature 27°C DB/19°C WB, water temperature 25°C, water temperature slope 5°C, pressure 0Pa; Heating: indoor temperature 20°C DB/15°C WB, water temperature 15°C, water flow same as for cooling, pressure 0Pa.

SH/MH/H/M/L/ML/SL	super high / mid high / high / mid / low / mid low / super low
EXV	electromagnetic expansion valve
R32	(single component refrigerant HFC), GWP of refrigerant used: 675.
R410A	(50% HFC-32, 50% HFC-125), GWP 2088
R134A	(100% HFC-134a), GWP 1300
R290	(100% CH3CH2CH3), GWP 3
ID/OD	indoor unit/outdoor unit

This catalogue is informative only and does not constitute a binding offer from the side of SINCLAIR CORPORATION LTD.
The Company takes no responsibility for any damage arising out of using or interpretation of this catalogue.
The noise levels mentioned in this catalogue are values measured under ideal conditions, in an anechoic chamber.
These values can be influenced by local conditions (acoustical bouncing area, the equipment of the room, etc).
The specification of products is subject to change based on further development of the units by the producer and can be changed without prior notice.
The reproduction of information or data, in particular the use of texts, text excerpts or images, requires the prior written approval of the company.
The contents of this catalogue is protected by copyright of SINCLAIR CORPORATION LTD.

