

A-A (1 : 9)

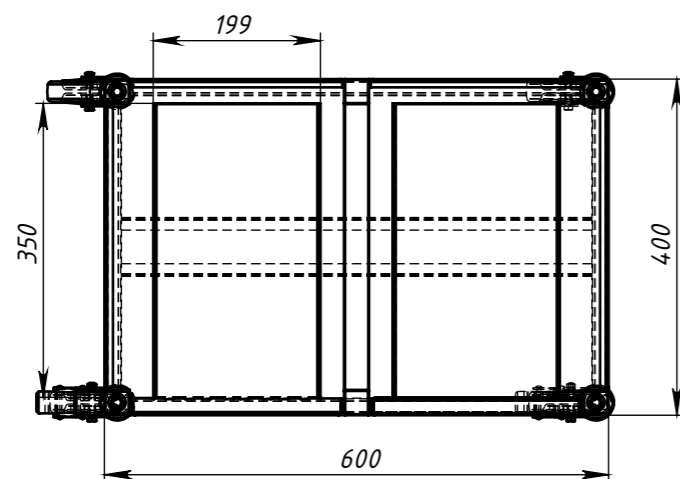
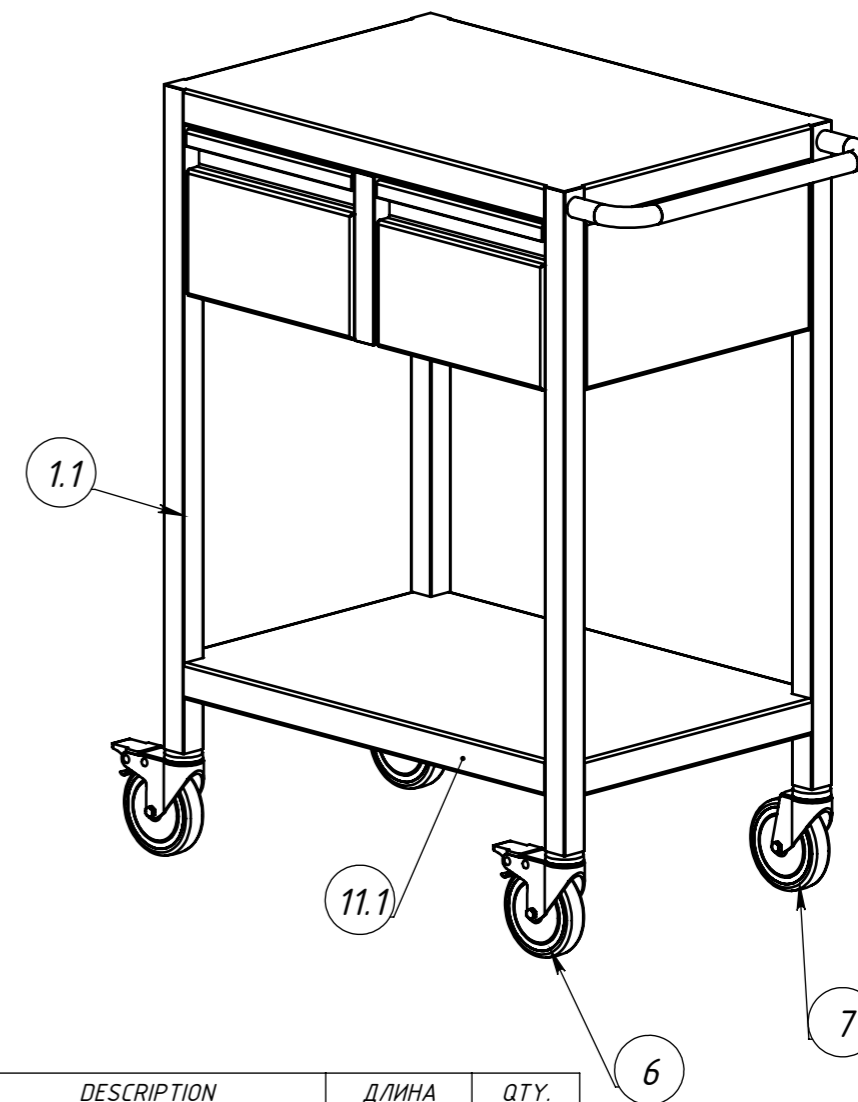
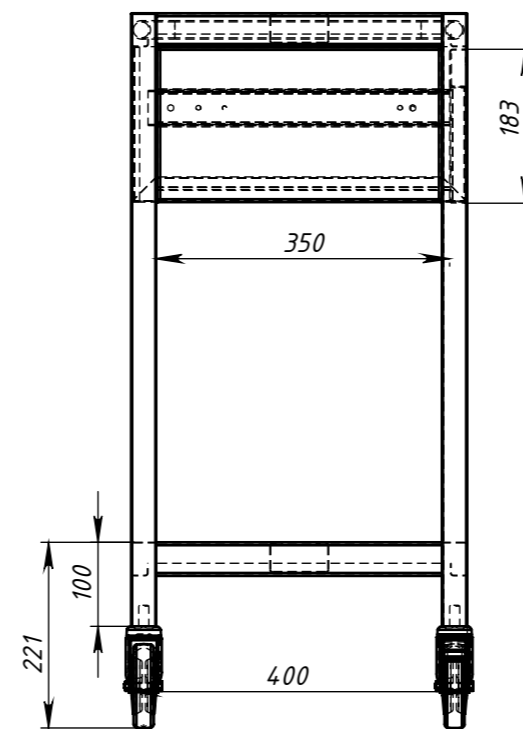

ITEM NO.	PART NUMBER	DESCRIPTION	ДЛИНА	QTY.
1	Carcasa 900x500			1
1.1		Profil 30x30x1.2	729	4
2	sertar			2
3	Laterala	S 0,8		2
4	Spate	S0,8		1
5	Ranfort 860	S0.8		2
6	Roata 100 cu frina			2
7	Roata 100 ff			2
8	suport			1
8.1		Profil 30 X 30 X 1,2	185	2
8.2		Profil 30 X 30 X 1,2	400	1
9	MirrorSpate			1
10	polita 900x500 N2	S0.8		1
11	polita 900x500 N1	S0.8		1
11.1		Sheet		1
12	Miner			1
12.1		Teava 22 X 3.2	40	2
12.2		PIPE 22 X 3.2	62.83	2
12.3		PIPE 22 X 3.2	293	1
13	Laterala gl dr2			2
14	MirrorLaterala gl dr2			2

No	
Client	-
Inginer	Pleşivţev Artiom
Termen ex.2025

Carucior 600x400x850 cu 2 sertare si 2 polite

METAL EXPERT
— TECHNOLOGY —