

SEWER MANHOLES AND INSPECTION CHAMBERS

DIAMIR

RELIABLE COMPONENTS
OF SEWER AND DRAINAGE SYSTEMS



ENVIRONMENTAL FRIENDLY SOLUTIONS

ISO 14001

ISO 9001





Contents

Introduction	4 - 6
Inspection chambers DIAMIR 315	
Description	7 - 9
Assortment	10 - 13
Inspection chambers DIAMIR 400	
Description	14 - 16
Assortment	17 - 20
Inspection chambers DIAMIR 425	
Description	21 - 23
Assortment	24 - 28
Catch basins with a sump DIAMIR 315, 400, 425	
Description	29
Assortment	30 - 32
Inspection chambers DIAMIR 315; 400; 425	
Installation instructions	33
Chamber tops, solution options	34 - 36
Inspection chambers DIAMIR 600	
Description	37 - 39
Assortment	40 - 44
Installation instructions	45
Chamber tops, variants	46 - 47
Manholes DIAMIR 1000	
Description	48 - 50
Assortment	51 - 54
Installation instructions	55 - 56
Manhole tops, solution options	56 - 57
Special chambers	58 - 60

Intended use

DIAMIR manholes are intended for construction of gravitational sewer systems (sanitary, storm-water, combined, industrial sewage systems) and drainage.

The offer includes the following manhole types:

- non-entry inspection chambers, allowing for access to the storm water or sanitary sewage systems with inspection or cleaning devices,
- entry manholes (inspection manholes) enabling staff to have access to storm-water or sanitary sewage systems
- catch basins with sumps are used in storm-water drainage systems. If “blind” base units are applied, chambers are used as, e.g., tanks, sewage pumping stations or wells.

Standards, approvals

PN-EN 13598-2:2009 Plastics piping systems for non-pressure underground drainage and sewerage - Unplasticized poly(vinyl chloride) (PVC-U), polypropylene (PP) and polyethylene (PE) - Part 2: Specifications for manholes and inspection chambers in traffic areas and deep underground installations

PN-EN 124:2000 Gully tops and manhole tops for vehicular and pedestrian areas – Design requirements, type testing, marking, quality control

PN-EN 476:2011 General requirements for components used in drains and sewers

PN-EN 681-1 :2002 Elastomeric seals. material requirements for pipe joint seals used in water and drainage applications — Part 1 : Rubber

Technical Approval **AT/2010-02-0830** “DIAMIR” Manholes and inspection chambers made of polypropylene (PP), poly(vinyl chloride)(PCV) and polyethylene (PE) issued by the Road and Bridge Research Institute in Warsaw

Technical Approval **AT/07-2011-0242-00** „DIAMIR” Manholes and inspection chambers made of polypropylene (PP), poly(vinyl chloride)(PCV) and polyethylene (PE) issued by the Railway Institute in Warsaw

Technical Approval **AT/2011-02-2706** Reinforced concrete tops for plastic gullies and manholes issued by the Road and Bridge Research Institute in Warsaw

Production technology

DIAMIR manhole base units are manufactured of polypropylene (PP) with the injection method. The method ensures very high accuracy and repeatability of the production process. Riser pipes and telescope pipes are manufactured of polypropylene (PP) and polyvinyl chloride (PVC) with the method of extrusion.

Resistance

Polypropylene is material of exceptional resistance to chemical substances, strokes, very low and high temperatures and stress corrosion. The maximum temperature of flowing sewage for PP base units equals 95 °C, and the minimum ambient temperature during installation of manhole components made of PP is – 20 °C. Manhole/inspection chamber components made of PVC should not be assembled at temperature below zero. All manhole elements made of PP or PVC and elastomeric gaskets are resistant to domestic sewage and storm water. However, if industrial sewage is involved, its chemical composition, concentration and temperature should be analysed. Resistance of PP and PVC is specified in the ISO/TR 10358 guidelines, whereas resistance of elastomeric seals – in ISO/TR 7620. In case of any doubts please do not hesitate to consult our technical advisor.

Merits

Use of **DIAMIR** manholes ensures:

- cost savings resulting from low weight of individual chamber components, which makes it possible to reduce to the minimum use of heavy equipment and construction of access roads,
- total tightness against infiltration of groundwater and extrafiltration of sewage into the ground which might contaminate the environment



- excellent hydraulic properties, low sewage flow resistance and no pollutants sedimentation in the base unit,

- high durability, inspection and cleaning are easy thanks to the optimised manhole design
- high resistance to ground water uplift pressure and adaptation to variable climatic conditions thanks to fins on manhole components,
- speedy and easy assembly thanks to push-on pipe joints with gaskets



- a potential for attaining essentially any height up to 6 meters and the telescopic top section of a chamber makes it possible to adjust accurately its height matching the pavement level,

- a wide range of base units makes design and construction easier and use of ball-and-socket joints in connection hubs makes it possible to change pipeline direction by $\pm 7,5^\circ$ and to connect a manhole to a steep sewer,

- at least 100 – year lifetime thanks to the application of cutting edge technologies, plastics resistant to abrasion, aggressive sewage as well as high impact resistance and elongation at break.



Quality control

All the types of the offered manholes/chambers are subjected to laboratory and field tests for durability, tightness and resistance to static and dynamic loads. The management system based on EN ISO 9001 implemented in Barbara Kaczmarek enterprise ensures rigorous supervision over quality of our products.



Selection of a top

Location of a manhole affects a choice of an appropriate gully or manhole top adapted to the local load conditions. A top class should be specified in a technical design. For DIAMIR manholes/chambers, tops of A, B, C, and D classes (according to EN 124:2000) are used in road ROWs. In green areas, where small loads occur, unclassified tops may be applied.

Group 1 (min. Class A15) Areas intended solely for pedestrians and pedal cyclists;

Group 2 (min. Class B125) Roads and areas for pedestrians, and comparable areas, parking lots or places where cars are parked;

Group 3 (min. Class C250) Applies solely do sewer gully tops installed in the area of kerbside channels of roads, which extends a maximum of 0,5 m into a carriageway and a maximum of 0,2 m into the footway when measured from the kerb edge;

Group 4 (min. Class D400) Carriageways of roads (including pedestrian streets) hard shoulders, and parking areas for all types of road vehicles

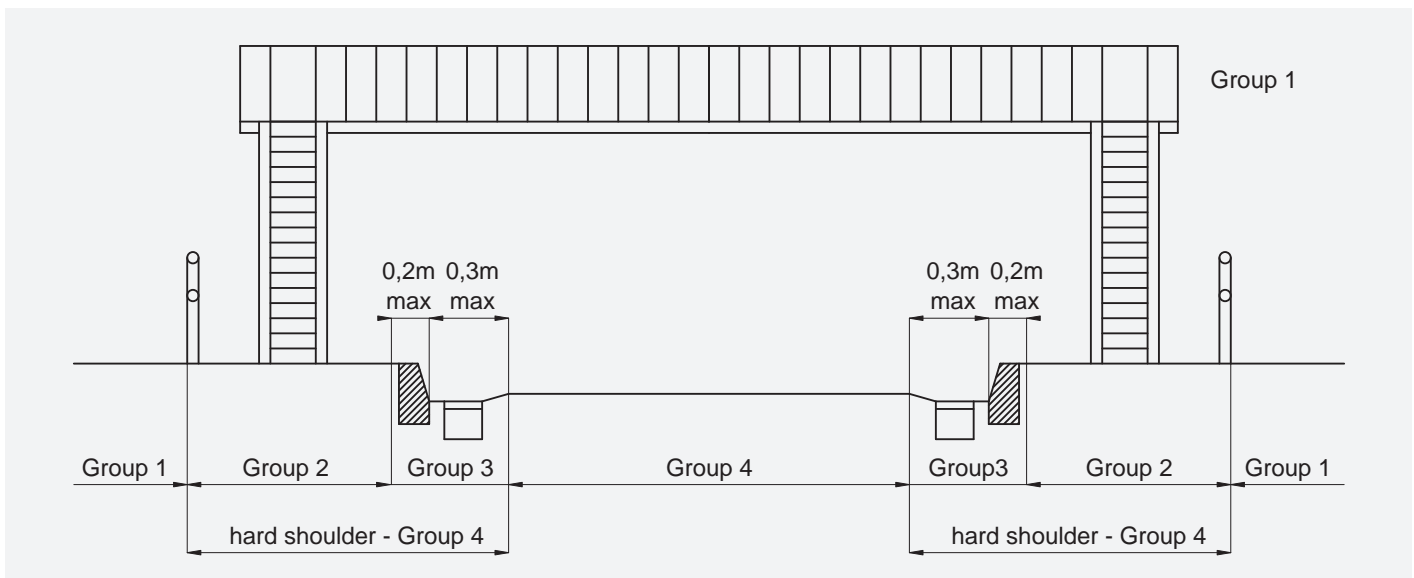

Classification

Our company offers five state-of-the-art manhole systems called DIAMIR. The number after the name stands for a diameter of a riser pipe or a chamber of modular sections.

The systems offered include the following:

- DIAMIR 315
- DIAMIR 400
- DIAMIR 425
- DIAMIR 600
- DIAMIR 1000

Technical features

Non-entry inspection chambers **DIAMIR 315**

Main components of a chamber:

-**base unit, a base of an inspection chamber**, allowing for direct connection of storm water drainage or sanitary sewer systems installed in the ground, including incorporated channels with possible branches

-**a riser pipe** of internal diameter equalling 315

-**a telescope section**, allowing for compensation of settlement which may take place after installation and making it possible to adjust the chamber height. A telescope pipe is installed to the depth of 0,8 m below the ground level.



Standards:

-DIAMIR 315 inspection chamber is compliant with

EN 13598-2:2009

EN 476:2011

-approval for use in road ROWs

Technical Approval **IBDiM AT/2010-02-0830**

Technical Approval **IK AT/07-2011-0242-00**

Technical Approval **IBDiM AT/2011-02-2706**

-GIG (Central Mining Institute) Opinion approving their use in the areas of mining damages up to the 4th category;

-Resistance of PP chamber components to chemical substances is compliant with the guidelines issued by

ISO/TR 10358

-Gully tops and manhole tops meet the requirements of standard

EN 124:2000

-Seals meet the requirements of standard

EN 681-1:2002

-Chemical resistance of elastomeric seals to chemical substances is compliant with the requirements of the

ISO/TR 7620 Guidelines

Usage:

-maximum installation depth 6 m

-acceptable ground water table 5 m

-acceptable load caused by traffic SLW60 according to ATV-A127P

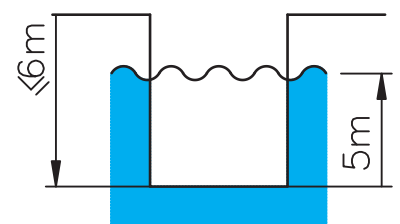

Technical features

Technical data

Base units are made of polypropylene (PP), with reinforcing ribs. They are adapted to connection with vertical riser pipes. There is a horizontal channel in the base unit with one or a few inlet connector pipes and one outlet connector pipe ending with hubs for connection with plain wall pipes made of PVC-U, PP or PE.



Type 1	Type 2		Type 3		Type 4		
DN	DN 1	DN	DN 1	DN 1	DN	DN	DN 1
110	110	110	110	110	110	110	110
160	160	160	160	160	160	160	160
200	200	200	200	200	200	200	200

A ball-and-socket joints $\pm 7,5^\circ$ may be used in connection bells 160, 200 (page 28)

Height adjustment

Non-entry inspection chambers **DIAMIR 315**

Specifications and height adjustment

In specifications for materials required for an investment total numbers of individual inspection chamber components should be indicated:

- base units
- riser pipes
- tops

The input parameter is chamber height specified in the design – the difference between the ground level and the chamber invert (base unit level). We label it as **Hs**. In order to make calculations easier, there is effective height (**Hu**) specified for each base unit type, that is, the distance between the bottom of a base unit and the bottom of base unit bell in which a riser pipe is installed.

For calculations, we label the height of a riser pipe as **Hw**. The effective height of a top section (telescope) will be **Ha**. One should bear in mind that the effective height of the telescope must not be smaller that thickness of the structural pavement layer. Height of a non-entry inspection chamber **DIAMIR 315**

$$H_s = H_u + H_w + H_a$$

$$H_a = H_t + H_z$$

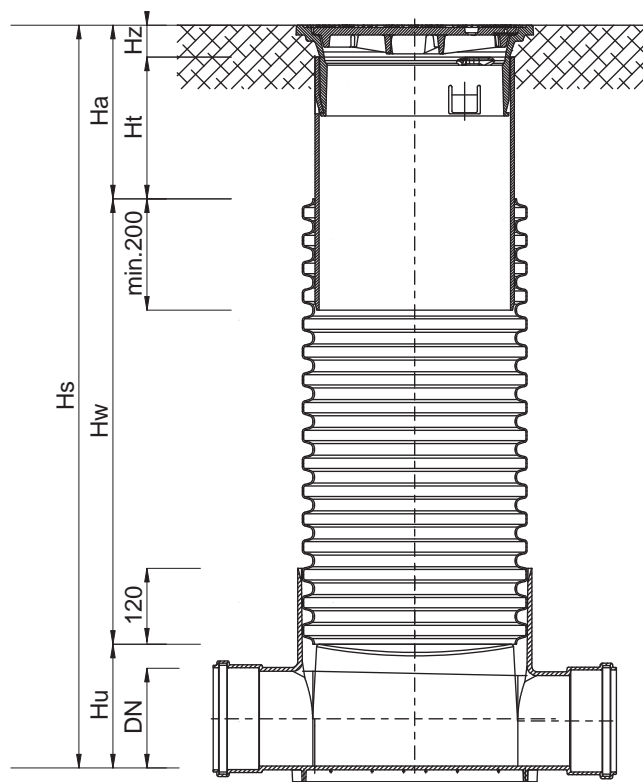

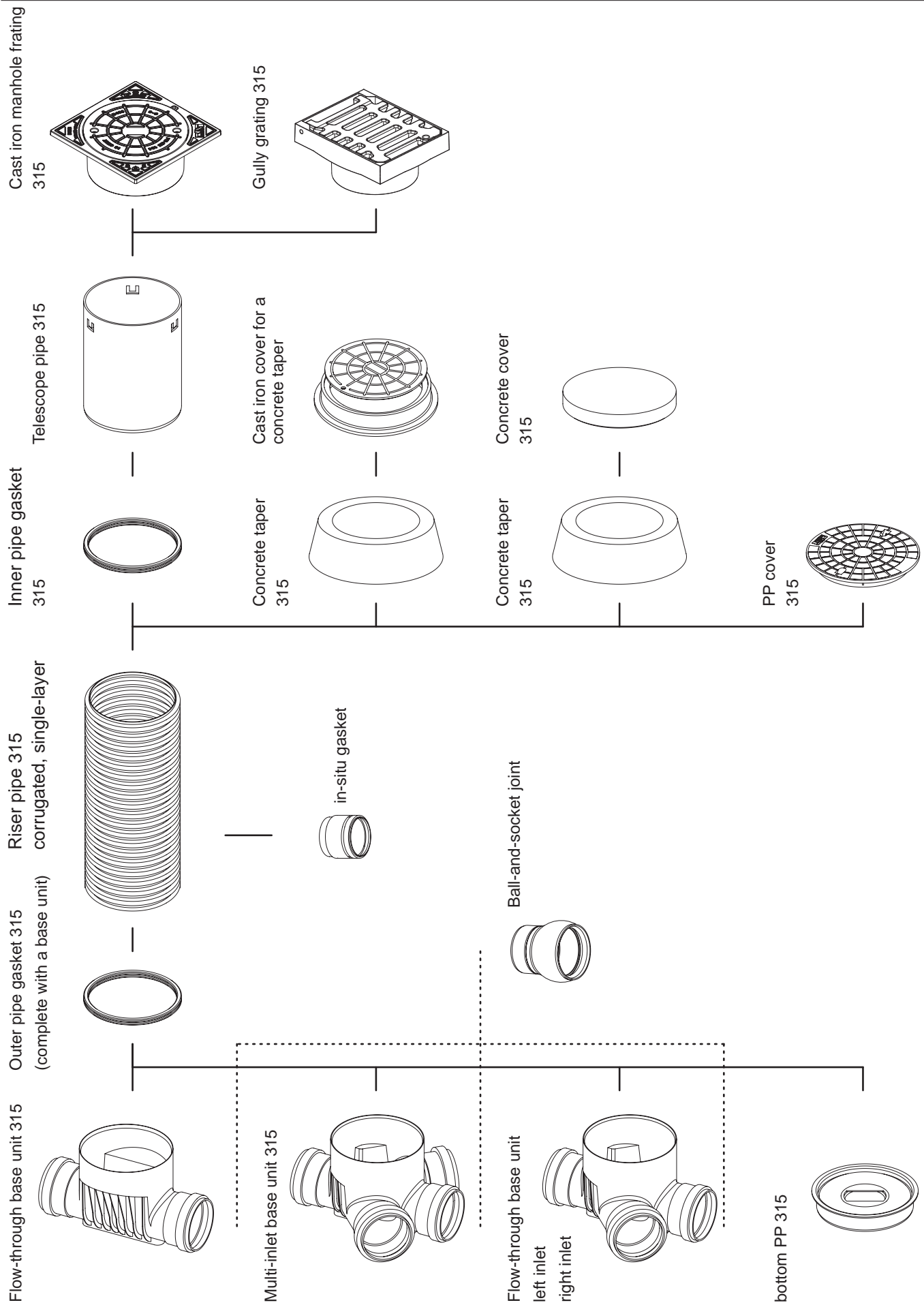

Flow-through base unit

with a gasket

Type 1

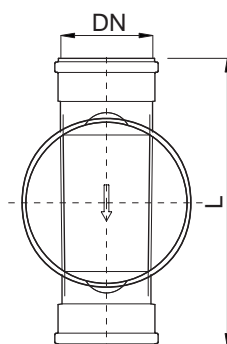
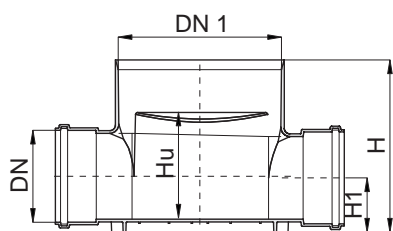

DN [mm]	DN 1 [mm]	H [mm]	Hu [mm]	H1 [mm]	L [mm]	Weight [kg]	index -
110	355	282	145	68	564	2,9	2531110300
160	355	337	192	100	636	3,6	2531120300
200	355	382	234	122	632	4,1	2531130300

Kineta zbiorcza 315

with a gasket

Type 2

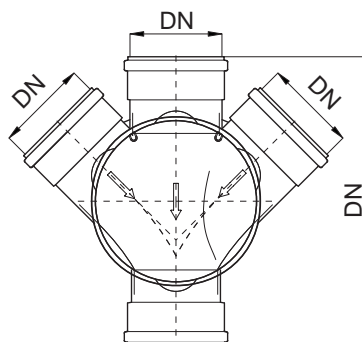
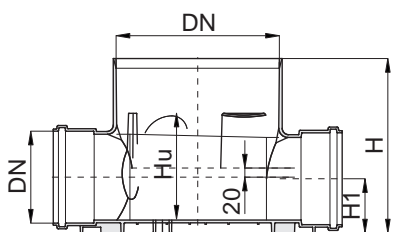

DN [mm]	DN 1 [mm]	H [mm]	Hu [mm]	H1 [mm]	L [mm]	Weight [kg]	index -
110	355	282	148	68	564	3,3	2532110300
160	355	337	192	100	636	4,4	2532120300
200	355	377	234	122	632	5,3	2532130300

Flow-through base unit 315

with a gasket
with left inlet

Type 3

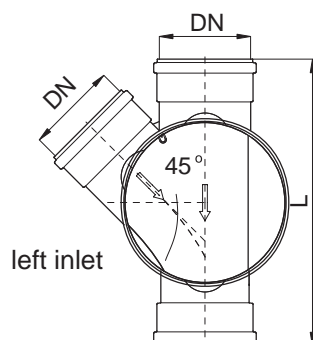
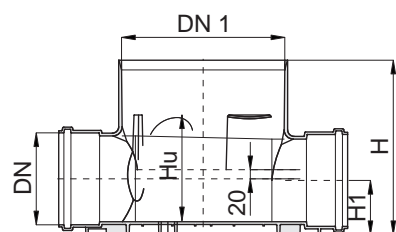

DN [mm]	DN 1 [mm]	H [mm]	Hu [mm]	H1 [mm]	L [mm]	Weight [kg]	index -
110	355	282	145	68	564	3,1	2533113300
160	355	337	192	100	636	4,0	2533123300
200	355	382	234	122	632	4,5	2533133300

Flow-through base unit 315

with a gasket
with right inlet

Type 4

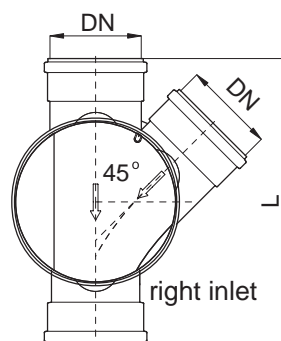
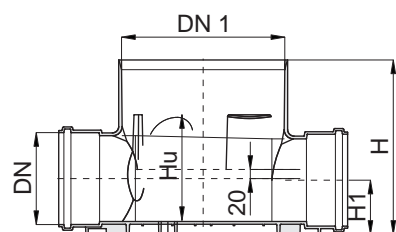

DN [mm]	DN 1 [mm]	H [mm]	Hu [mm]	H1 [mm]	L [mm]	Weight [kg]	index -
110	355	282	145	68	564	3,1	2534113300
160	355	337	192	100	636	4,0	2534123300
200	355	382	234	122	632	4,5	2534133300

Riser pipe 315

corrugated, single-layer
SN 4

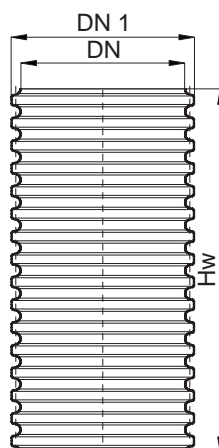

DN [mm]	DN 1 [mm]	Hw [mm]	Weight [kg]	index -
315	355	1000	4,0	2713312100
315	355	2000	8,0	2713312200
315	355	3000	12,0	2713312300
315	355	6000	24,0	2713312600

Telescope pipe 315

for cast iron chamber cover 315

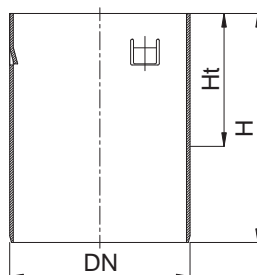

DN [mm]	H [mm]	Ht [mm]	Weight [kg]	index -
315	400	200	3,7	2781321040
315	800	600	7,4	2781321080

Cast iron chamber cover 315

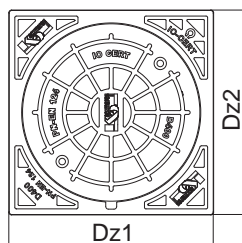
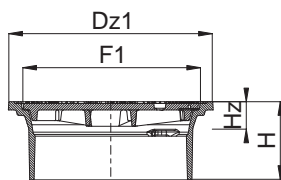

	Dz1 [mm]	Dz2 [mm]	F1 [mm]	H [mm]	Hz [mm]	Weight [kg]	index -
A15	375	375	320	143	50	20,5	2901131100
B125	375	375	320	143	50	22,9	2901132100
B125 K	375	375	320	143	50	22,3	2902132100
D400	375	375	320	143	50	31,5	2901134100
D400 K	420	340	395/320	150	60	40,0	2902134100

Corrugated pipe gasket 315

all-purpose

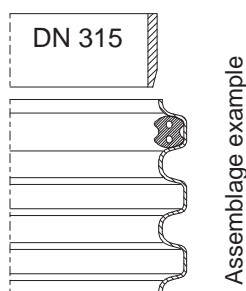
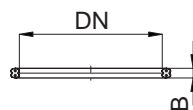

DN [mm]	B [mm]	Weight [kg]	index -
315	20	0,3	5162131050

a gasket installed outside or inside a riser pipe groove

Concrete cover 315

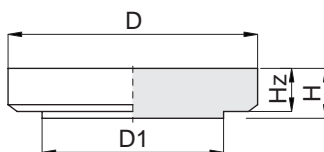

DN [mm]	D [mm]	D1 [mm]	H [mm]	Hz [mm]	Weight [kg]	index -	
A15	315	510	355	110	95	51,3	2952131000

Cast iron chamber cover 315

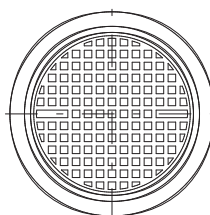
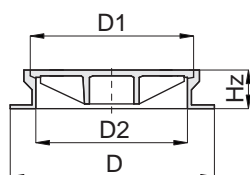

DN [mm]	D [mm]	D1 [mm]	D2 [mm]	Hz [mm]	Weight [kg]	index -	
B125	315	450	375	325	70	26,0	2901142500

Concrete taper 315

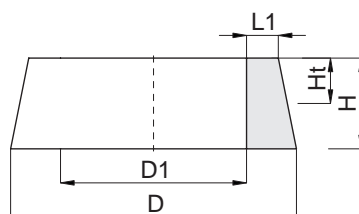

DN [mm]	D [mm]	D1 [mm]	L1 [mm]	H [mm]	Ht [mm]	Weight [kg]	index -	
B125	315	565	365	70	220	110	65,6	2951132000

PP Cover 315

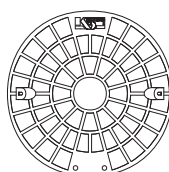
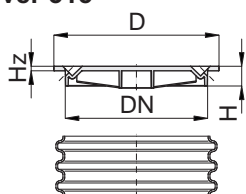

DN [mm]	D [mm]	H [mm]	Hz [mm]	Weight [kg]	index -	
A15	315	364	110	95	1,3	2539405090

Technical features

Technical features

Non-entry inspection chambers **DIAMIR 400**

Main components of a chamber

-a **base unit, a base of an inspection chamber**, allowing for direct connection of storm water drainage or sanitary sewer systems installed in the ground, including incorporated channels with possible branches

-a **riser pipe** of external diameter equalling 400

-a **telescope section**, allowing for compensation of settlement which may take place after installation and making it possible to adjust the chamber height. A telescope pipe is installed to the depth of 0,8 m below the ground level.



Standards:

-DIAMIR 400 inspection chamber is compliant with

EN 13598-2:2009

EN 476:2011

-approval for use in road ROWs

Technical Approval **IBDiM AT/2010-02-0830**

Technical Approval **IK AT/07-2011-0242-00**

Technical Approval **IBDiM AT/2011-02-2706**

-GIG (Central Mining Institute) Opinion approving their use in the areas of mining damages up to the 4th category;

-Resistance of PP chamber components to chemical substances is compliant with the guidelines issued by

ISO/TR 10358

-Gully tops and manhole tops meet the requirements of standard

EN 124:2000

-Seals meet the requirements of standard

EN 681-1:2002

-Chemical resistance of elastomeric seals to chemical substances is compliant with the requirements of the

ISO/TR 7620 Guidelines

Usage:

-maximum installation depth 6 m

-acceptable ground water table 5 m

-acceptable load caused by traffic SLW60 according to ATV-A127P

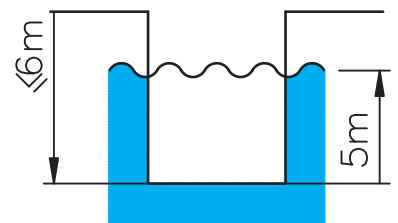

Technical features

Technical data

Base units are manufactured of polypropylene, with reinforcing ribs. They are adapted to connection with vertical riser pipes. There is a horizontal channel in the base unit with one or a few inlet connector pipes and one outlet connector pipe ending with hubs for connection with plain wall pipes made of PVC-U, PP or PE or connector pipes adapted to connection with structural pipes K2-KAN.

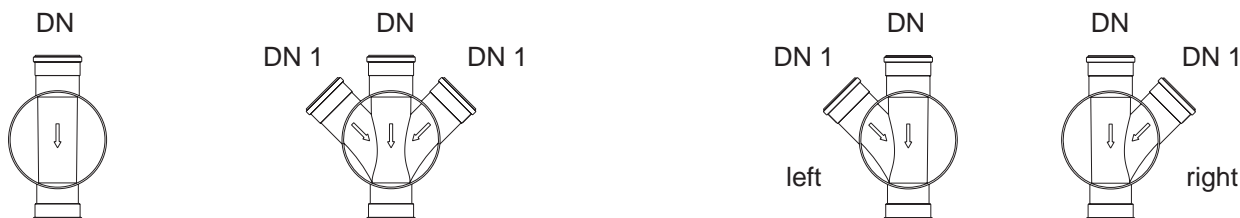

Type 1	Type 2		Type 3		Type 4		
DN	DN 1	DN	DN 1	DN 1	DN	DN	DN 1
110	110	110	110	110	110	110	110
160	160	160	160	160	160	160	160
200	200	200	200	200	200	200	200
250	250	250	250	250	250	250	250
315	315	315	315	315	315	315	315
400	200-315	400	200-315	200-315	400	400	200-315
200K2-Kan	200K2-Kan	200K2-Kan	200K2-Kan	200K2-Kan	200K2-Kan	200K2-Kan	200K2-Kan
250K2-Kan	250K2-Kan	250K2-Kan	250K2-Kan	250K2-Kan	250K2-Kan	250K2-Kan	250K2-Kan
300K2-Kan	300K2-Kan	300K2-Kan	300K2-Kan	300K2-Kan	300K2-Kan	300K2-Kan	300K2-Kan
400K2-Kan	200-300	400K2-Kan	200-300	200-300	400K2-Kan	400K2-Kan	200-300

A ball-and-socket joints $\pm 7,5^\circ$ may be used in connection bells 160, 200, 250, 315 (page 28)

Height adjustment

Non-entry inspection chambers DIAMIR 400

Specifications and height adjustment

Preparing specifications for materials required for an investment, total numbers of individual inspection chamber components should be indicated:

-base units, -riser pipes, -tops

The input parameter is chamber height specified in the design – the distance between the ground level and the chamber invert (base unit level). We label it as **Hs**. In order to make calculations easier, there is effective height (**Hu**) specified for each base unit type, that is, the distance between the bottom of a base unit and the bottom of base unit bell in which a riser pipe is installed.

For calculations, we label the height of a riser pipe as **Hw**. The effective height of a top section (telescope) will be **Ha**. One should bear in mind that the useful height of the telescope must not be smaller than thickness of the structural pavement layer.

Height of a non-entry inspection chamber DIAMIR 400

$$H_s = H_u + H_w + H_a$$

$$H_a = H_t + H_z$$

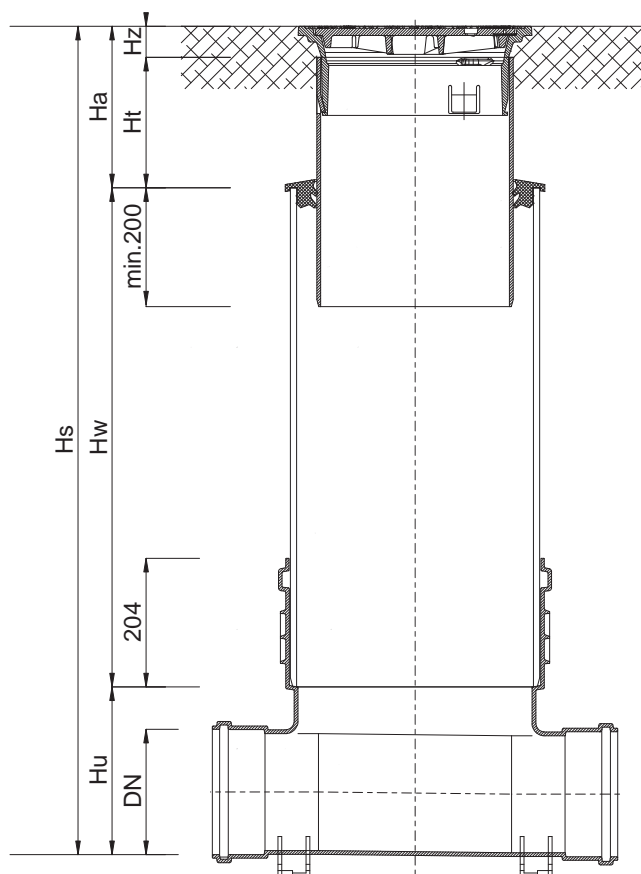

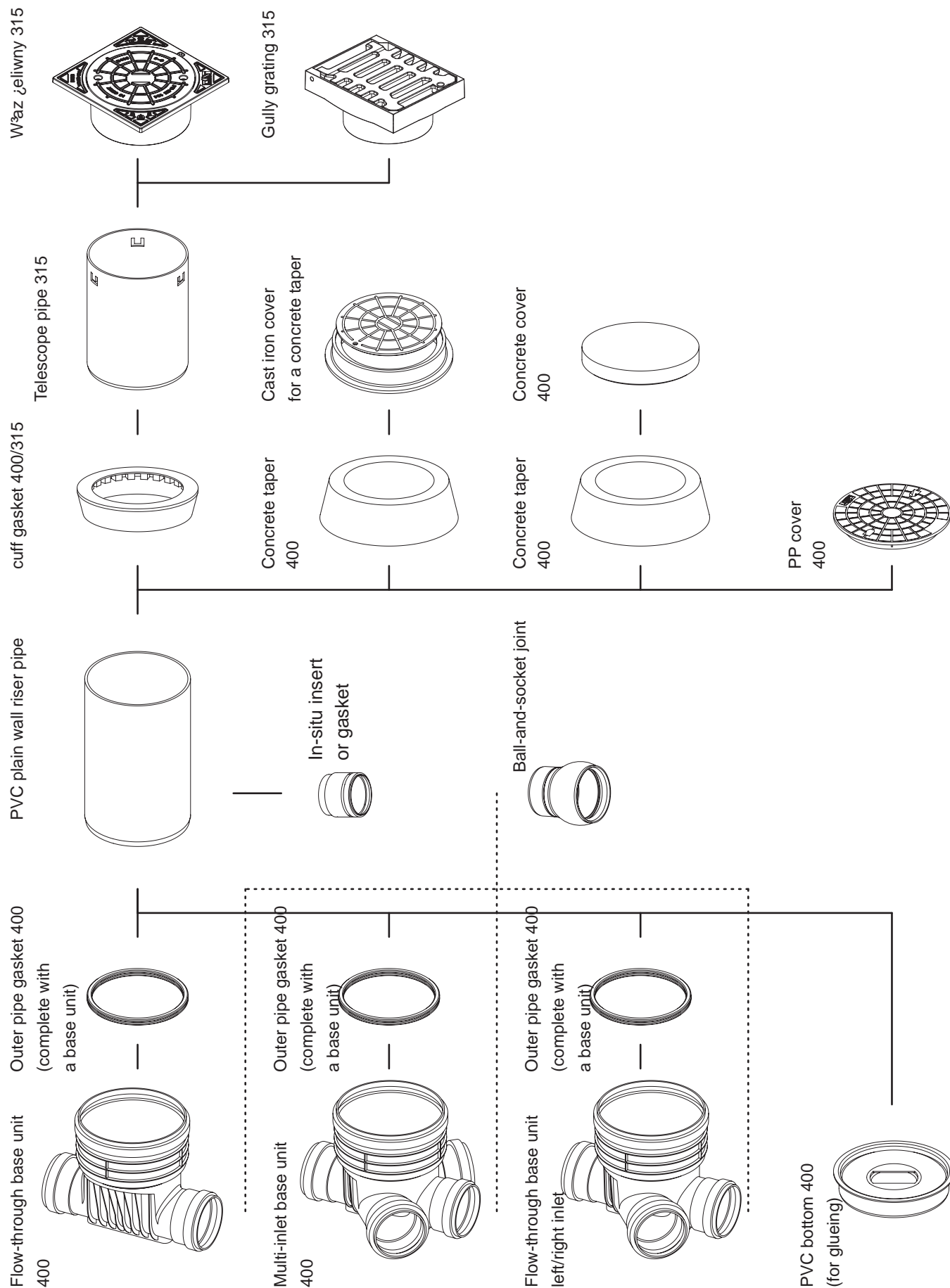

Flow-through base unit 400

with a gasket

Type 1

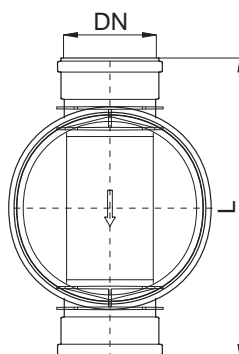
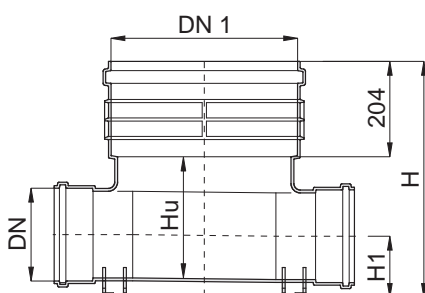

DN [mm]	DN 1 [mm]	H [mm]	Hu [mm]	H1 [mm]	L [mm]	Weight [kg]	index -
110	400	400	180	68	564	4,2	2541110300
160	400	492	244	116	622	4,0	2541120300
200	400	511	263	136	650	4,7	2541130300
250	400	714	455	168	1154	14,2	2541140300
315 **	400	714	455	198	1072	13,7	2541150300
400 **	400	714	455	238	1076	14,8	2541160300
200 K2 *	400	511	263	136	680	4,7	2541530300
250 K2 *	400	714	455	174	1074	14,1	2541540300
300 K2 *	400	714	455	198	1070	14,0	2541550300
400 K2 *	400	714	455	250	984	14,1	2541560300

* no gaskets in connection bells

** base unit outlet – bare end

Multi-inlet base 400

with a gasket

Type 2

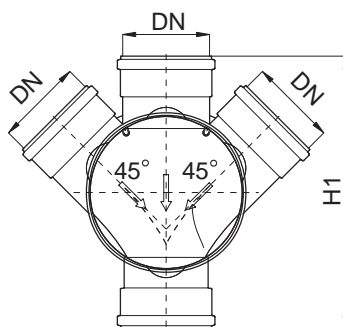
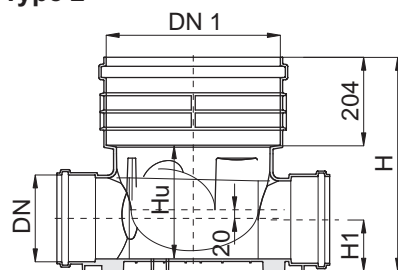

DN [mm]	DN 1 [mm]	H [mm]	Hu [mm]	H1 [mm]	L [mm]	Weight [kg]	index -
110	400	400	180	58	564	4,6	2541110300
160	400	456	222	100	636	5,4	2541120300
200	400	496	259	122	632	6,1	2541130300
250	400	714	455	168	1154	17,0	2541140300
315 **	400	714	455	198	1072	19,1	2541150300
200 K2 *	400	496	259	122	732	6,3	2541530300
250 K2 *	400	714	455	174	1074	16,9	2541540300
300 K2 *	400	714	455	198	1070	19,4	2541550300

* no gaskets in connection bells

** base unit outlet – bare end

Flow-through base unit 400

with a gasket, with left inlet

Type 3

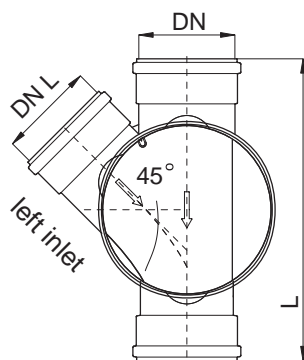
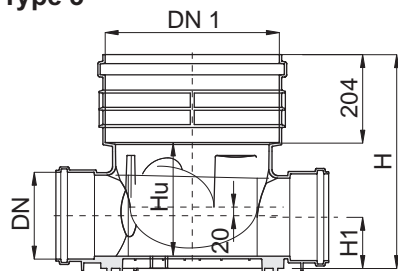

DN [mm]	DN L [mm]	DN 1 [mm]	H [mm]	Hu [mm]	H1 [mm]	L [mm]	Weight [kg]	index -
110	110	400	492	246	116	622	4,3	2543113300
160	160	400	492	246	116	622	4,6	2543123300
200	200	400	511	264	136	650	5,2	2543133300
250	250	400	720	462	168	1154	14,7	2543143300
315 **	315	400	720	462	198	1072	14,2	2543153300
200K2 *	200K2 *	400	400	180	68	564	4,5	2543533300
250K2 *	250K2 *	400	720	462	198	1072	14,2	2543543300
300K2 *	300K2 *	400	720	462	198	1072	14,2	2543553300

* no gaskets in connection bells

** base unit outlet – bare end

Flow-through base unit 400

with a gasket, with right inlet

Type 4

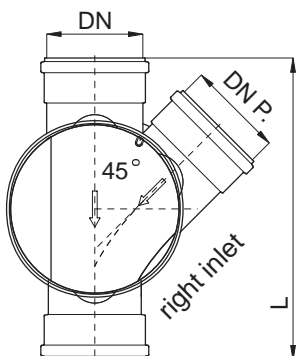
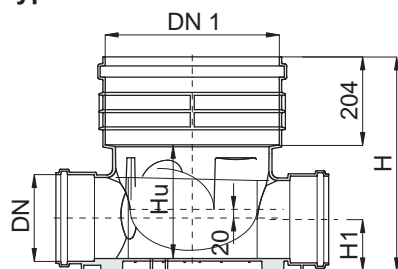

DN [mm]	DN L [mm]	DN 1 [mm]	H [mm]	Hu [mm]	H1 [mm]	L [mm]	Weight [kg]	index -
110	110	400	492	246	116	622	4,3	2544113300
160	160	400	492	246	116	622	4,6	2544123300
200	200	400	511	264	136	650	5,2	2544133300
250	250	400	720	462	168	1154	14,7	2544143300
315 **	315	400	720	462	198	1072	14,2	2544153300
200K2 *	200K2 *	400	400	180	68	564	4,5	2544533300
250K2 *	250K2 *	400	720	462	198	1072	14,2	2544543300
300K2 *	300K2 *	400	720	462	198	1072	14,2	2544553300

* no gaskets in connection bells

** base unit outlet – bare end

Unit base with additional inlets

with left or right inlet (45° or 90°)

with left and right inlet (45° or 90°)

DN [mm]	DN L [mm]	DN P. [mm]	DN 1 [mm]	H [mm]	Hu [mm]	H1 [mm]	L [mm]
400	200-300	200-300	400	720	462	198	1154
400	400 (90°)	400 (90°)	400	720	462	198	1154
400 K2	200-300	200-300	400	720	462	198	1154
400 K2	400 (90°)	400 (90°)	400	720	462	198	1154

Riser pipe 400

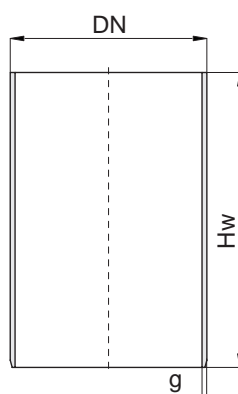

DN [mm]	g [mm]	L [mm]	Weight [kg]	index -
400	7,9	1000	14,7	2713411100
400	7,9	2000	29,3	2713411200
400	7,9	3000	43,9	2713411300
400	7,9	6000	87,7	2713411600
400	9,8	3000	56,1	2713421300
400	9,8	6000	112,3	2713421600

Telescope pipe 315

for a cast iron manhole top

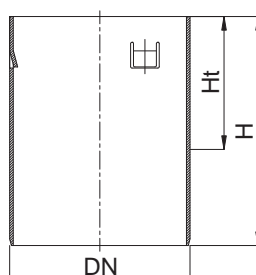

DN [mm]	H [mm]	Ht [mm]	Weight [kg]	index -
315	400	200	3,7	2781321040
315	800	600	7,4	2781321080

Cast iron chamber cover 315

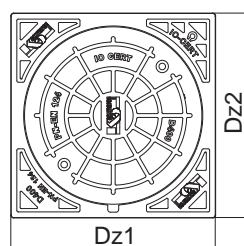
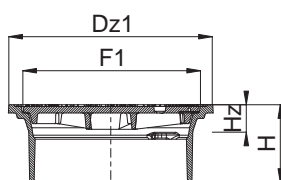

	Dz1 [mm]	Dz2 [mm]	F1 [mm]	H [mm]	H _z [mm]	Weight [kg]	index -
A15	375	375	320	143	50	20,5	2901131100
B125	375	375	320	143	50	22,9	2901132100
B125 K	375	375	320	143	50	22,3	2902132100
D400	375	375	320	143	50	31,5	2901134100
D400 K	420	340	395/320	150	60	40,0	2902134100

Cuff gasket 400/315

for a telescope pipe

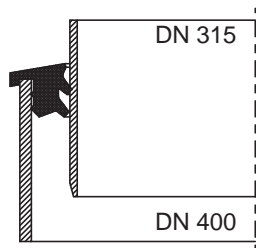
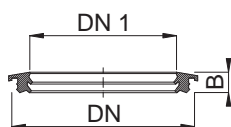

Installation example



DN [mm]	DN 1 [mm]	B [mm]	Weight [kg]	index -
400	315	45	2,2	5165311060

Concrete cover 400

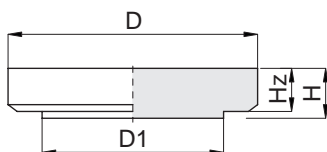

DN [mm]	D [mm]	D1 [mm]	H [mm]	Hz [mm]	Weight [kg]	index -	
A15	400	550	400	110	95	59,7	2952141000

Cast iron chamber cover 400

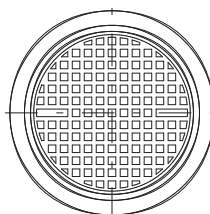
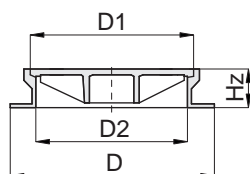

DN [mm]	D [mm]	D1 [mm]	D2 [mm]	Hz [mm]	Weight [kg]	index -	
B125	315	450	375	325	70	26,0	2901142500

Concrete taper 400

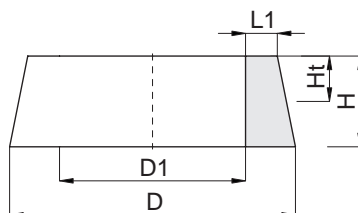

DN [mm]	D [mm]	D1 [mm]	L1 [mm]	H [mm]	Ht [mm]	Weight [kg]	index -	
B125	400	630	410	70	200	100	65,6	2951142000

PP Cover 400

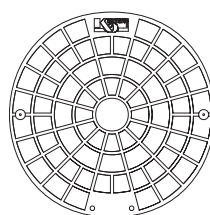
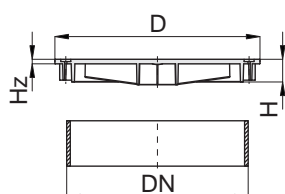

DN [mm]	D [mm]	H [mm]	Hz [mm]	Weight [kg]	index -	
A15	400	452	50	10	1,8	2549405090

Technical features

Non-entry inspection chambers **DIAMIR 425 NW**

Main components of a chamber

-a **base unit, a base of an inspection chamber**, allowing for direct connection of storm water drainage or sanitary sewer systems installed in the ground, including incorporated channels with possible branches

-a **riser pipe of internal diameter equalling 425**

-a **telescope section, allowing for compensation of settlement** which may take place after installation and making it possible to adjust the chamber height. A telescope pipe is installed to the depth of 0,8 m below the ground level.



Standards:

-DIAMIR 425 NW inspection chamber is compliant with

EN 13598-2:2009

EN 476:2011

-approval for use in road ROWs

Technical Approval **IBDiM AT/2010-02-0830**

Technical Approval **IK AT/07-2011-0242-00**

Technical Approval **IBDiM AT/2011-02-2706**

-GIG (Central Mining Institute) Opinion approving their use in the areas of mining damages up to the 4th category;

-Resistance of PP chamber components to chemical substances is compliant with the guidelines issued by

ISO/TR 10358

-Gully tops and manhole tops meet the requirements of standard

EN 124:2000

-Seals meet the requirements of standard

EN 681-1:2002

-Chemical resistance of elastomeric seals to chemical substances is compliant with the requirements of the

ISO/TR 7620 Guidelines

Usage:

-maximum installation depth 6 m

-acceptable ground water table 5 m

-acceptable load caused by traffic SLW60 according to ATV-A127P

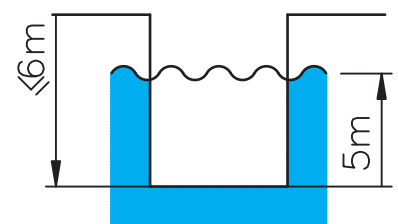

Technical features

Technical data

Base units are made of polypropylene (PP), with reinforcing ribs. They are adapted to connection with vertical riser pipes. There is a horizontal channel in the base unit with one or a few inlet connector pipes and one outlet connector pipe ending with bells for connection with plain wall pipes made of PVC-U, PP or PE or connector pipes adapted to connection with structural pipes K2-KAN.



Type 1	Type 2		Type 3		Type 4		
DN	DN 1	DN	DN 1	DN 1	DN	DN	DN 1
110	110	110	110	110	110	110	110
160	160	160	160	160	160	160	160
200	200	200	200	200	200	200	200
250	250	250	250	250	250	250	250
315	315	315	315	315	315	315	315
400	200-400	400	200-400	200-400	400	400	200-400
200K2-Kan	200K2-Kan	200K2-Kan	200K2-Kan	200K2-Kan	200K2-Kan	200K2-Kan	200K2-Kan
250K2-Kan	250K2-Kan	250K2-Kan	250K2-Kan	250K2-Kan	250K2-Kan	250K2-Kan	250K2-Kan
300K2-Kan	300K2-Kan	300K2-Kan	300K2-Kan	300K2-Kan	300K2-Kan	300K2-Kan	300K2-Kan
400K2-Kan	200-400	400K2-Kan	200-400	200-400	400K2-Kan	400K2-Kan	200-400

A ball-and-socket joints $\pm 7,5^\circ$ may be used in connection bells 160; 200; 250; 315 (page 28)

Height adjustment

Non-entry inspection chambers DIAMIR 425

Specifications and height adjustment

Preparing specifications for materials required for an investment, total numbers of individual inspection chamber components should be indicated:

-base units, -riser pipes, -tops

The input parameter is chamber height specified in the design – the distance between the ground level and the chamber invert (base unit level). We label it as **Hs**.

In order to make calculations easier, there is useful height (**Hu**) specified for each base unit type, that is, the difference between the bottom of a base unit and the bottom of base unit bell in which a riser pipe is installed.

For calculations, we label the height of a riser pipe as **Hw**. The height of a top section (telescope) will be **Ha**. One should bear in mind that the useful height of the telescope must not be smaller than thickness of the structural pavement layer.

No-entry inspection chamber DIAMIR 425

$$H_s = H_u + H_w + H_a$$

$$H_a = H_t + H_z$$

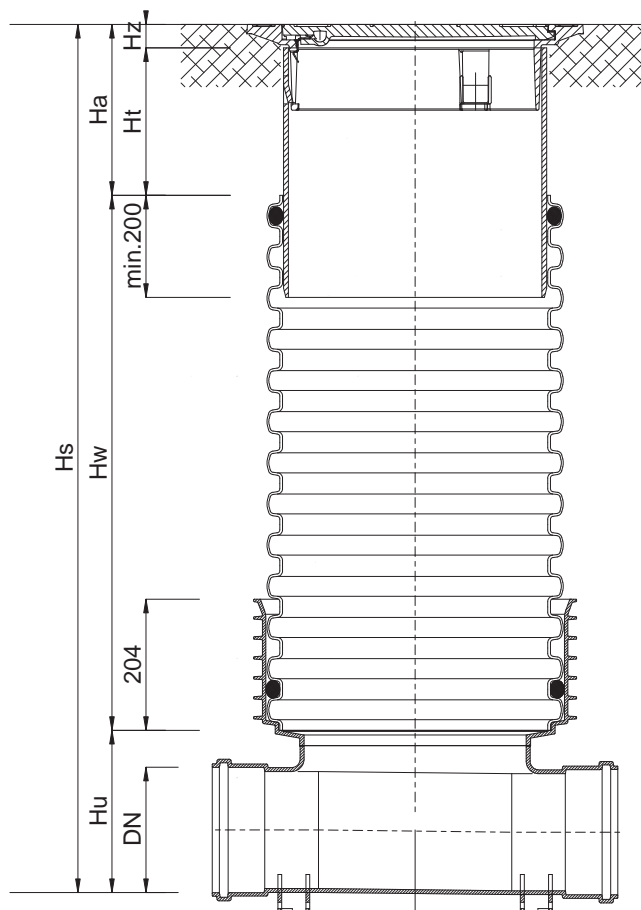

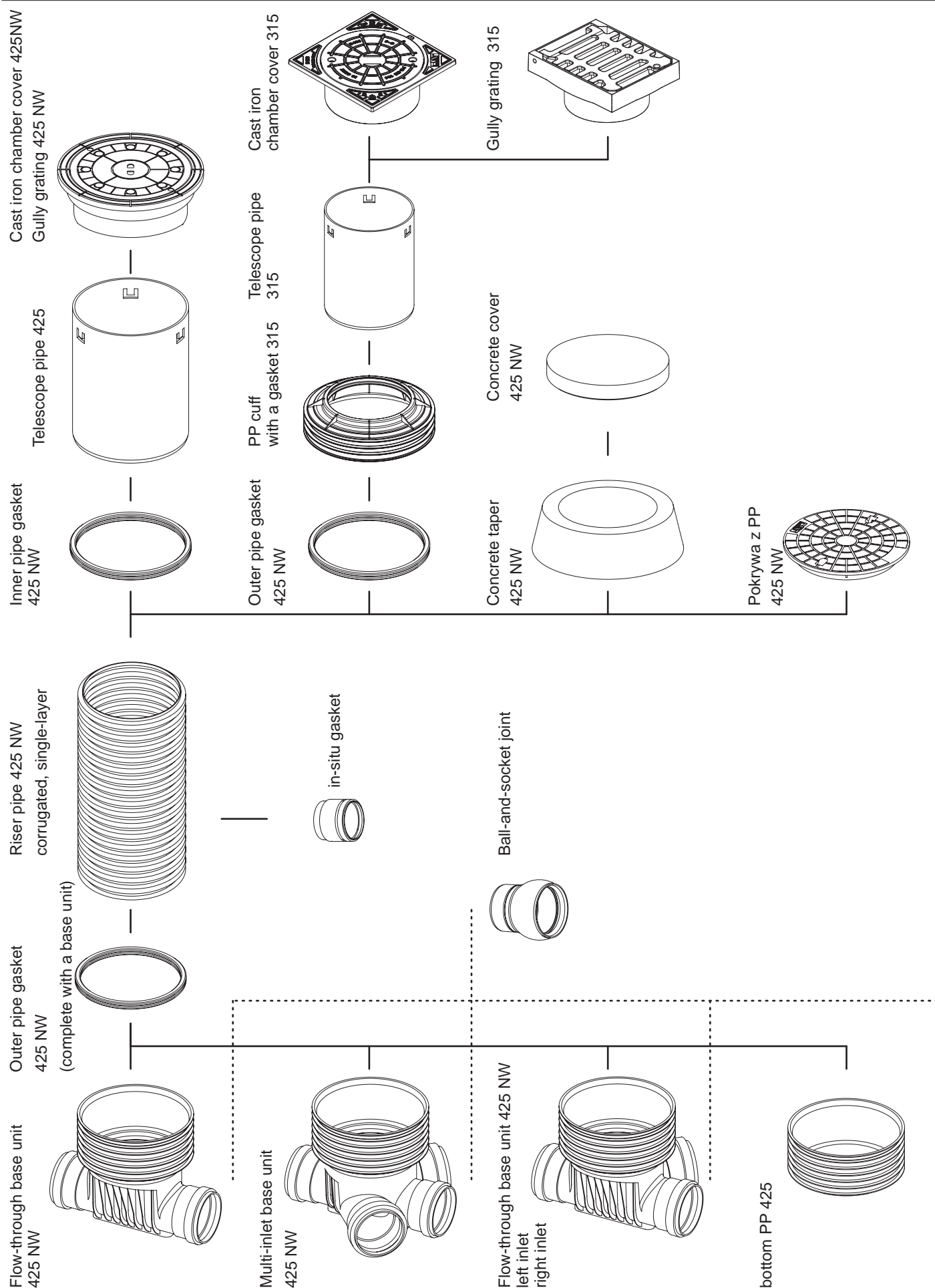

Flow-through base unit 425 NW

with a gasket

Type 1

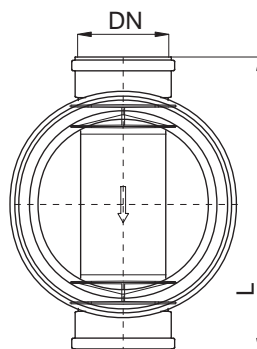
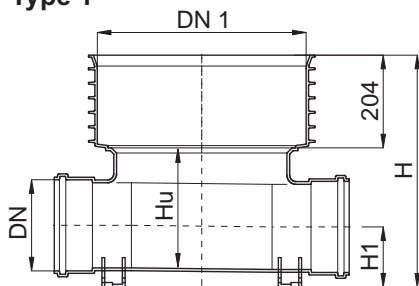

DN [mm]	DN 1 [mm]	H [mm]	Hu [mm]	H1 [mm]	L [mm]	Weight [kg]	index -
110	478	452	206	96	622	4,1	2561110300
160	478	492	246	116	622	4,6	2561120300
200	478	511	264	136	650	5,2	2561130300
250	478	720	462	168	1154	14,7	2561140300
315 **	478	720	462	198	1072	14,2	2561150300
400 **	478	720	462	238	1076	15,3	2561160300
200 K2 *	478	511	264	136	680	5,3	2561530300
250 K2 *	478	720	462	174	1074	14,6	2561540300
300 K2 *	478	720	462	198	1070	14,5	2561550300
400 K2 *	478	720	462	250	984	14,6	2561560300

* no gaskets in connection bells

** base unit outlet – bare end

Multi-inlet base unit 425 NW

with a gasket

Type 2

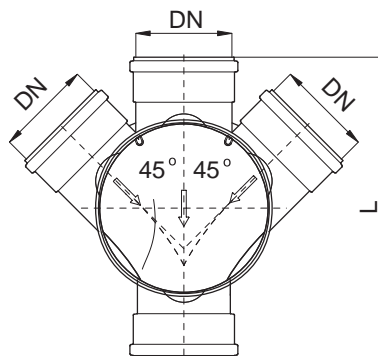
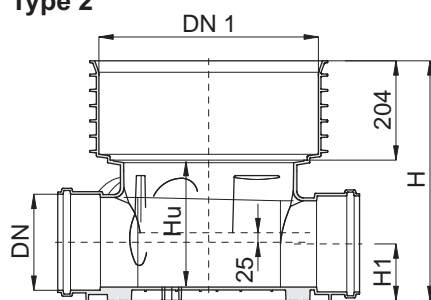

DN [mm]	DN 1 [mm]	H [mm]	Hu [mm]	H1 [mm]	L [mm]	Weight [kg]	index -
110	478	422	190	60	596	5,2	2561110300
160	478	462	230	100	636	5,9	2561120300
200	478	496	266	122	632	6,6	2561130300
250	478	720	462	168	1154	17,5	2561140300
315 **	478	720	462	198	1072	19,6	2561150300
200 K2 *	478	502	266	122	732	6,8	2561530300
250 K2 *	478	720	462	174	1074	17,4	2561540300
300 K2 *	478	720	462	198	1070	19,8	2561550300

* no gaskets in connection bells

** base unit outlet – bare end

Flow-through base unit 425 NW

with a gasket, with left inlet

Type 3

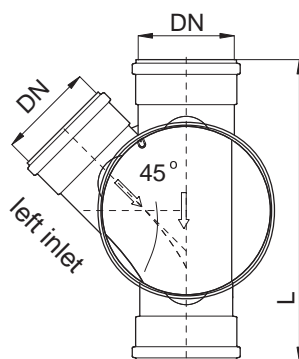
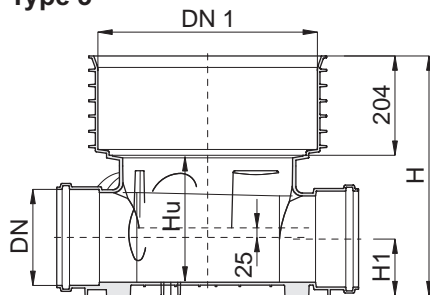

DN [mm]	DN L [mm]	DN 1 [mm]	H [mm]	Hu [mm]	H1 [mm]	L [mm]	Weight [kg]	index -
110	110	478	492	246	116	622	4,6	2563113300
160	160	478	492	246	116	622	4,6	2563123300
200	200	478	511	264	136	650	5,2	2563133300
250	250	478	720	462	168	1154	14,7	2563143300
315 **	315	478	720	462	168	1154	14,7	2563153300
200K2 *	200K2 *	478	511	264	136	680	5,3	2563533300
250K2 *	250K2 *	478	720	462	198	1072	14,2	2563543300
300K2 *	300K2 *	478	720	462	198	1072	14,2	2563553300

* no gaskets in connection bells

** base unit outlet – bare end

Flow-through base unit 425 NW

with a gasket, with right inlet

Type 4

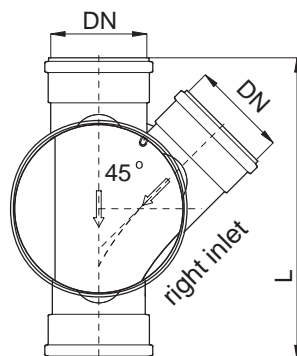
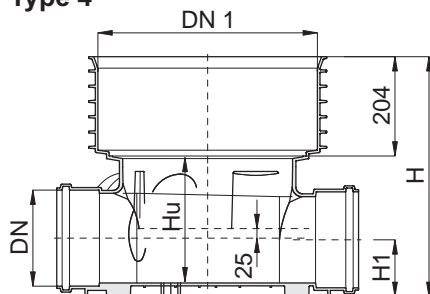

DN [mm]	DN L [mm]	DN 1 [mm]	H [mm]	Hu [mm]	H1 [mm]	L [mm]	Weight [kg]	index -
110	110	478	492	246	116	622	4,6	2564113300
160	160	478	492	246	116	622	4,6	2564123300
200	200	478	511	264	136	650	5,2	2564133300
250	250	478	720	462	168	1154	14,7	2564143300
315 **	315	478	720	462	168	1154	14,7	2564153300
200K2 *	200K2 *	478	511	264	136	680	5,3	2564533300
250K2 *	250K2 *	478	720	462	198	1072	14,2	2564543300
300K2 *	300K2 *	478	720	462	198	1072	14,2	2564553300

* no gaskets in connection bells

** base unit outlet – bare end

Flow-through base unit with additional inlets

with left or right inlet (45° or 90°)

with left and right inlet (45° or 90°)

DN [mm]	DN L [mm]	DN P. [mm]	DN 1 [mm]	H [mm]	Hu [mm]	H1 [mm]	L [mm]
400	200-300	200-300	478	720	462	198	1154
400	400 (90°)	400 (90°)	478	720	462	198	1154
400 K2	200-300	200-300	478	720	462	198	1154
400 K2	400 (90°)	400 (90°)	478	720	462	198	1154

Riser pipe 425 NW

corrugated, single layer
SN 4

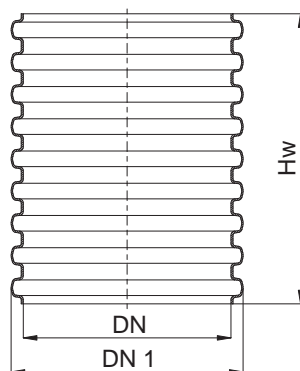

DN [mm]	DN 1 [mm]	Hw [mm]	Weight [kg]	index -
425	475	1000	6,7	2713632100
425	475	2000	13,4	2713632200
425	475	3000	20,1	2713632300
425	475	6000	40,2	2713632600

Telescope pipe 315

for a cast iron chamber cover

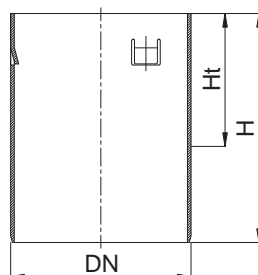

DN [mm]	H [mm]	Ht [mm]	Weight [kg]	index -
315	400	200	3,7	2781321040
315	800	600	7,4	2781321080

Cast iron chamber cover 315

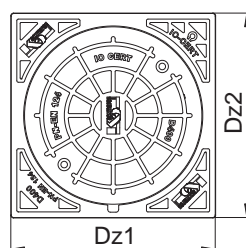
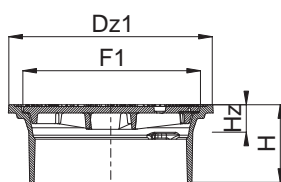

	Dz1 [mm]	Dz2 [mm]	F1 [mm]	H [mm]	H _z [mm]	Weight [kg]	index -
A15	375	375	320	143	50	20,5	2901131100
B125	375	375	320	143	50	22,9	2901132100
B125 K	375	375	320	143	50	22,3	2902132100
D400	375	375	320	143	50	31,5	2901134100
D400 K	420	470	340/340	150	60	40,0	2902134100

PP cuff 425 NW with a gasket 315

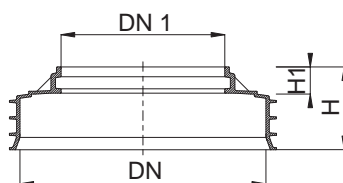

DN [mm]	DN 1 [mm]	H [mm]	H1 [mm]	Weight [kg]	index -
425	315	161	52	2,6	2569250090

Cast iron chamber cover 425 NW

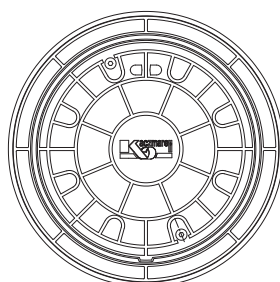
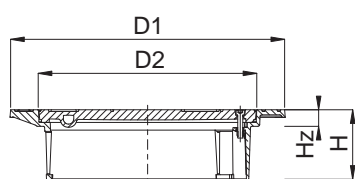

D400	D1 [mm]	D2 [mm]	H [mm]	H _z [mm]	Weight [kg]	index -
D400	540	428	138	35	36,0	2901164100

Telescope pipe 425

for a cast iron chamber cover 425 NW

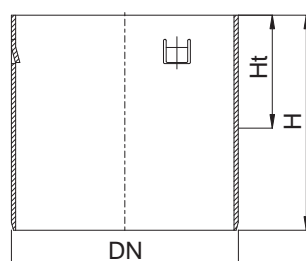

DN [mm]	H [mm]	H _t [mm]	Weight [kg]	index -
425	400	200	6,3	2781612040
425	800	600	12,6	2781612080

Corrugated pipe gasket 425 NW all-purpose

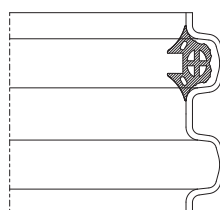

Assemblage example



DN [mm]	B [mm]	Weight [kg]	index -
425	49	1,0	5162151050

gasket installed outside or inside riser pipe groove

Concrete cover 425 NW

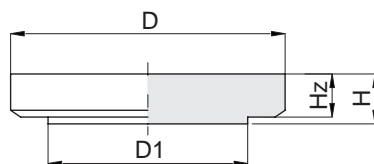

	DN [mm]	D [mm]	D1 [mm]	H [mm]	H _z [mm]	Weight [kg]	index -
A15	425	650	475	110	95	64,5	2952161000

Concrete taper 425 NW

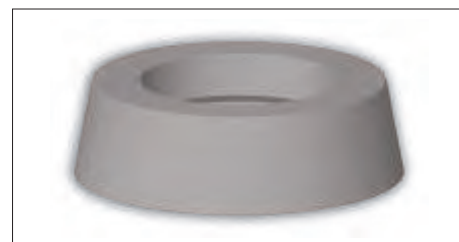
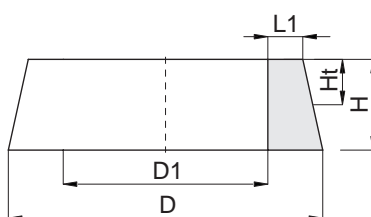

	DN [mm]	D [mm]	D1 [mm]	L1 [mm]	H [mm]	H _t [mm]	Weight [kg]	index -
B125	425	715	485	80	220	110	75,4	2951162000

PP cover 425 NW

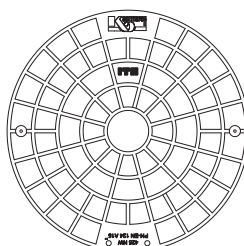
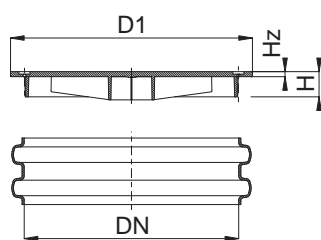

	DN [mm]	D1 [mm]	H [mm]	H _z [mm]	Weight [kg]	index -
A15	425	480	50	10	2,1	2569405090

Ball-and-socket joint

+/- 7,5°

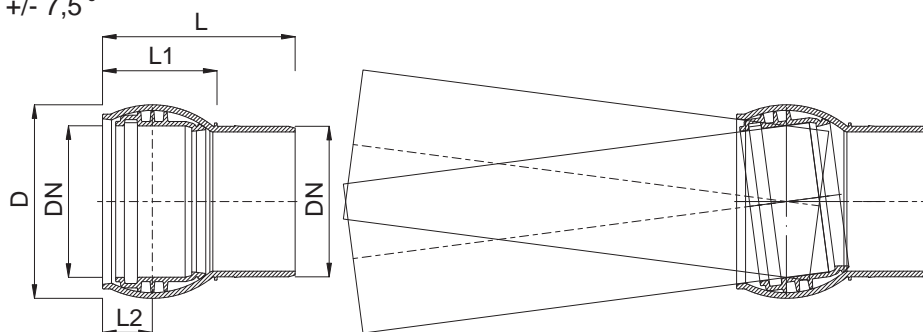

DN [mm]	D [mm]	L1 [mm]	L2 [mm]	L [mm]	Weight [kg]	index -
160	206	122	53	205	0,9	0718233310
200	254	146	63	245	1,7	0718253310
250	320	186	80	305	3,4	0718273310
315	395	217	92	362	6,1	0718293310

Catch basins with a sump **DIAMIR 315; 400; 425**

Solution options

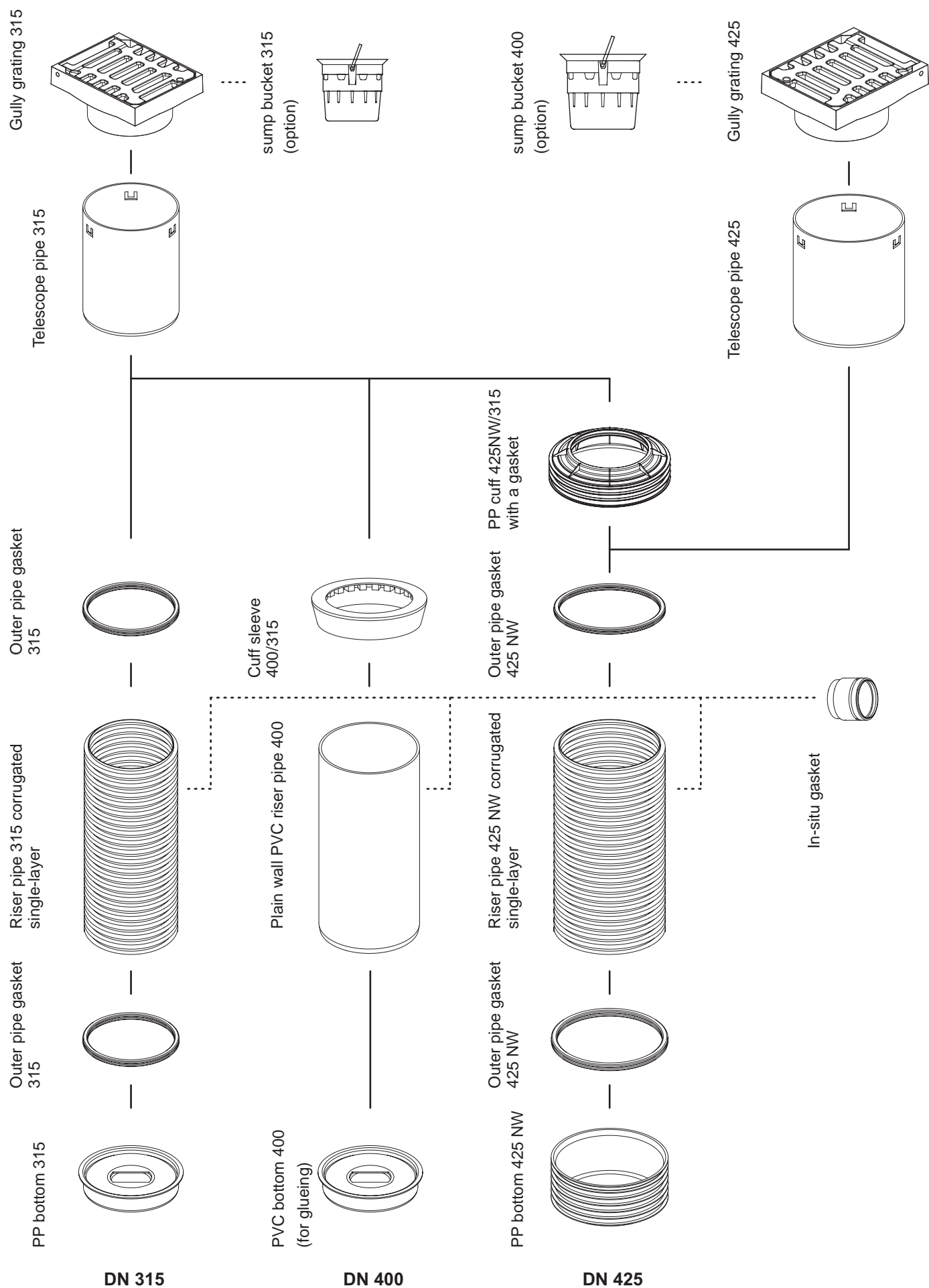

Catch basin with a sump

with a bottom

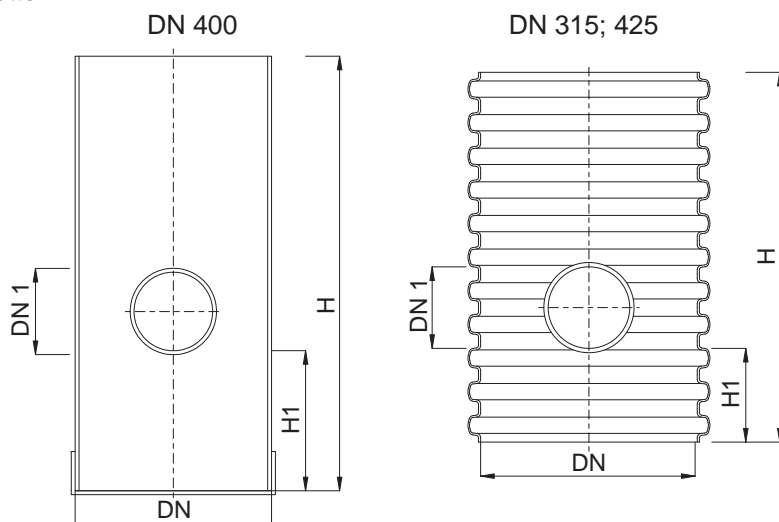

DN	Dw [mm]	Dz [mm]	D1 [mm]	H1 [mm]	H * [mm]	Weightindex [kg]	-
315	315	355	110	500	2000	9,0	2813110200
315	315	355	160	500	2000	9,9	2813120200
400	380	400	110	320	2000	48,3	2814110200
400	380	400	160	320	2000	49,0	2814120200
425	425	475	110	320	2000	15,5	2816110200
425	425	475	160	320	2000	16,1	2816120200

* other chamber heights are available on request

Stormwater gully

B125 K

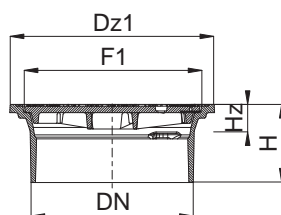
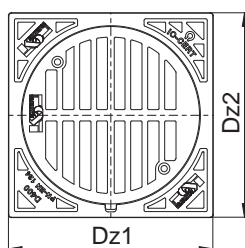

D400 K

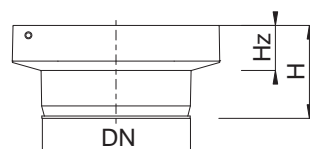
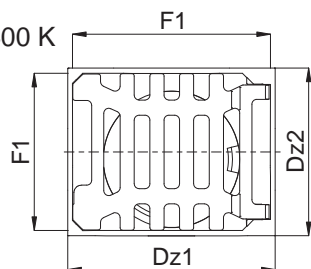

	DN [mm]	Dz1 [mm]	Dz2 [mm]	F1 [mm]	H [mm]	Hz [mm]	Inlet area [dm ²]	Weight [kg]	index -
B125 K	315	375	375	320	143	50	3,3	22,3	2902132100
D400 K	315	420	340	395/320	185	90	5,3	40,0	2902134100
D400 K	425	500	500	474/474	210	115	9,0	76,4	2902164100

Sump bucket

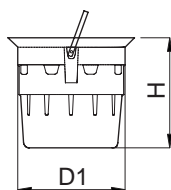

DN	D1 [mm]	H [mm]	Weight [kg]	index -
315	315	250	1,0	2981133100
400	400	240	3,0	2981163100

Telescope pipe

for a cast iron chamber cover

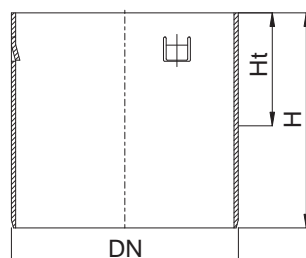

DN [mm]	H [mm]	Ht [mm]	Weight [kg]	index -
315	400	200	3,7	2781612040
315	800	600	7,4	2781612080
425	400	200	6,3	2781612040
425	800	600	12,6	2781612080

PP cuff 425 NW

with gasket 315

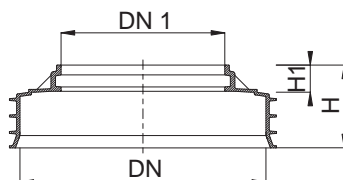

DN [mm]	DN 1 [mm]	H [mm]	H1 [mm]	Weight [kg]	index -
425	315	161	52	2,6	2569250090

Sump bottom



DN	D1 [mm]	H [mm]	Weight [kg]	index -
315	315	80	0,6	2539911090
400 *	400	105	4,0	2549921030
425	425	160	3,6	2569911030

* for gluing

Sump chamber gasket

all-purpose



DN	B [mm]	Weight [kg]	index -
315	20	0,3	5162131050
425	49	1,0	5162151050

a gasket installed outside or inside riser pipe groove

In-situ gasket

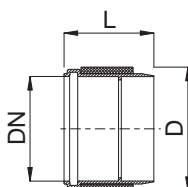

DN	D1 [mm]	L [mm]	Weight [kg]	index -
110	138	120	0,5	5168201010
160	177	120	0,8	5168231010

Hole cutter

Cutter holder – all-purpose

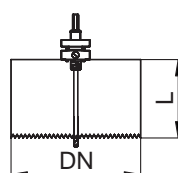

DN	D1 [mm]	L [mm]	Weight [kg]	index
110	138	90	0,8	5191202100
160	177	90	1,2	5191231100

all purpose	-	-	0,6	5191000100
-------------	---	---	-----	------------

Installation instructions

DIAMIR inspection chambers should be installed in conditions specified in the technical design. The ground around chambers (0.3 m) should be composed of compactable soil, approved for use in road construction according to standard PN-S-02205:1998. Earthworks should be carried out in accordance with standard PN-EN 1610:2002/Ap1:2007. Soil compaction should be performed in layers as specified in standard PN-ENV 1046:2007 to prevent from excessive ovalisation of a chamber cross-section.



1 Prepare a trench in an inspection chamber location removing large and sharp-edged stones. On the trench bottom prepare bedding composed of compactable soil, preferably sand (coarse- medium- or fine-grained) of minimum 10 cm thickness. An inspection chamber zone should include an area of at least a 30 cm wide strip around the chamber.



2 Place a base unit on a prepared earlier sand bedding and level it and then connect sewage pipes to the chamber.



3 Fill up the trench with preliminary backfill (10 cm above the pipe level). Compaction should be performed manually, in layers every 15 cm or with light mechanical equipment (each layer up to 30 cm). Base unit socket should protrude above the backfill level.



4 Prepare a corrugated riser pipe of the required length. The pipe can be cut to the required chamber height. Install a gasket in the lowest groove on the outside of the riser pipe. The gasket is delivered along with a base unit.



5 Lubricant should be applied on the inner side of a base unit socket and gasket. Products approved for rubber gaskets and plastic should be used.

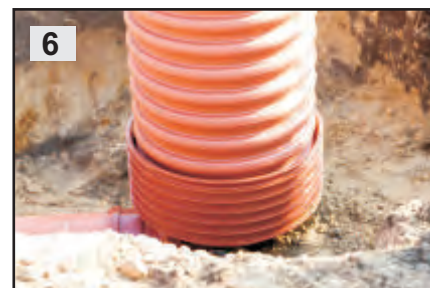

6 Insert a riser pipe with an installed gasket into a base unit.



7 Compact the area around the pipe. Compaction should be performed manually, in layers every 15 cm or with light mechanical equipment (each layer up to 30 cm) in open areas to at least 90% of the Proctor compaction test and for inspection chambers located in a carriageway or road shoulder backfill should meet the requirements specified for compaction index resulting from the installation depth, road construction type (cutting, embankment) or traffic intensity category.

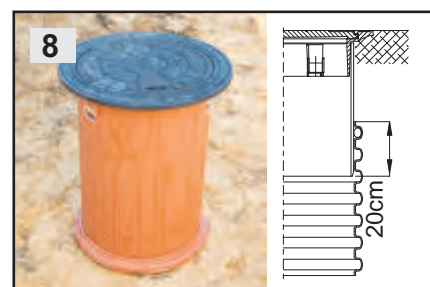

8 For inspection chambers equipped with riser pipes connected with telescope pipes with a gasket, ensure a telescope pipe is inserted into a riser pipe to the depth of approximately 20 cm.

Inspection chamber tops

Location of a DIAMIR chamber and expected load caused by traffic are the basis for selection of riser and telescope pipe stiffness and a choice of cast iron covers.

Depending on the chamber location within a ROW and a traffic intensity category, different manhole/gully tops are used, also construction requirements and top type which are classified into the following groups may differ.

Group 1 - Class A15 - green areas intended solely for pedestrians and pedal cyclists

Group 2 - Class B125 - Roads and areas for pedestrians, and comparable areas, parking lots or places where cars are parked

Group 3 - Class C250 - Applies solely do sewer gully tops installed in the area of kerbside channels of roads and road shoulders

Group 4 - Class D400 - Carriageways of roads (including pedestrian streets) hard shoulders, and parking areas for all types of road vehicles

There are different rules of the manhole/gully top support depending on their type and class, and soil conditions. A manhole/gully top should sit on a reinforced concrete slab which is supported by an appropriately constructed load bearing structure adapted to loads caused by traffic. That may be reinforced bedding made of well compacted soil or a precast load-relieving slab made of reinforced concrete.

For very heavy load caused by traffic or doubts about compaction of soil constituting the top base, a slab with the chamber top should be based on a B30 concrete ring of minimum height of 20 cast on the building site

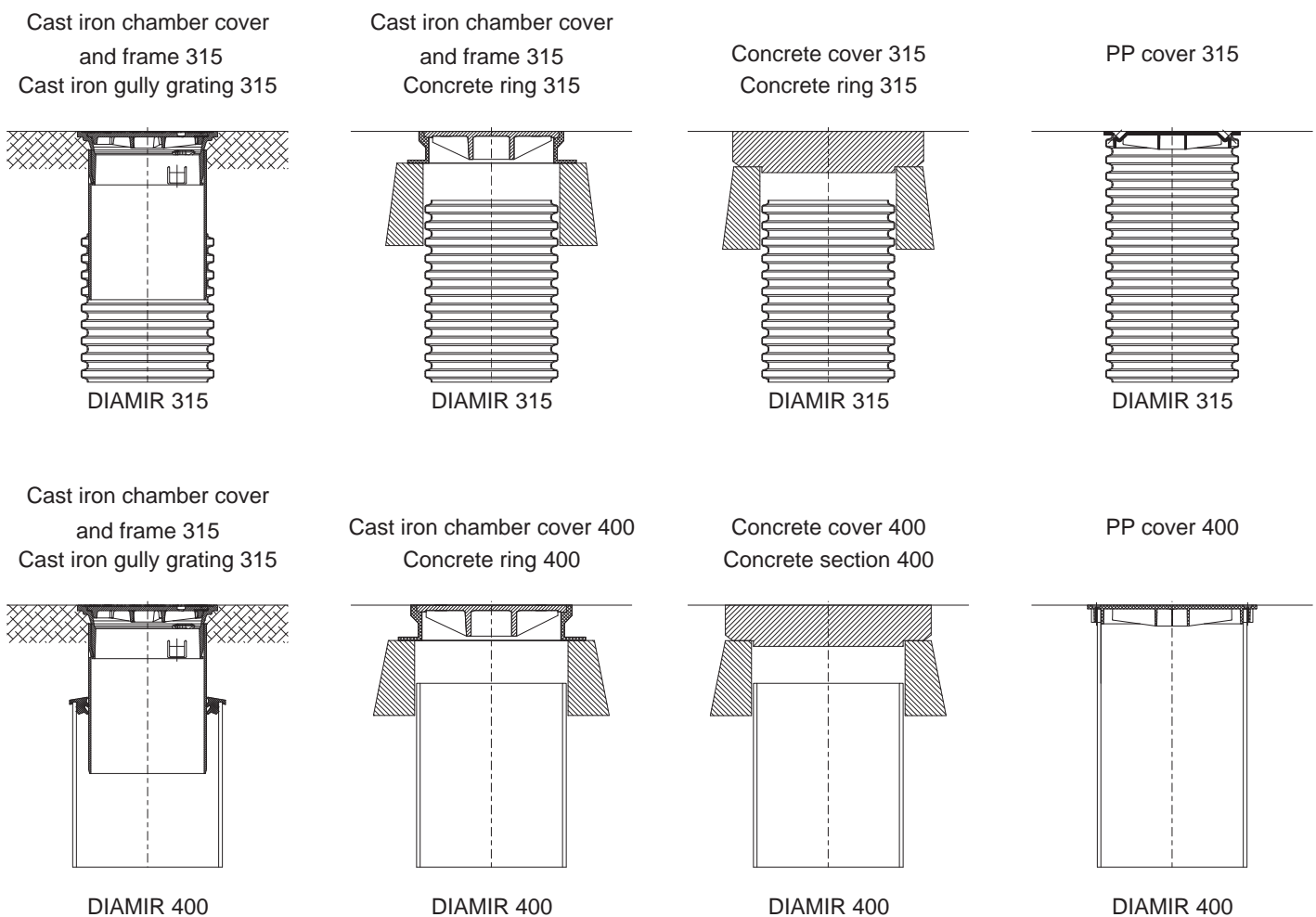

Inspection chamber tops

Cast iron cover and frame 425
Gully grating 425

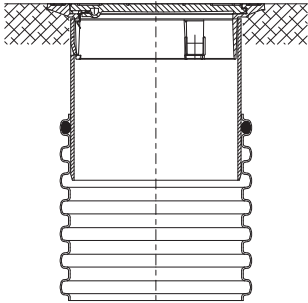

DIAMIR 425

Cast iron cover and frame 315
Gully grating 315

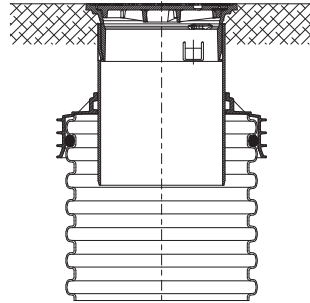

DIAMIR 425

Concrete cover 425
Concrete ring 425

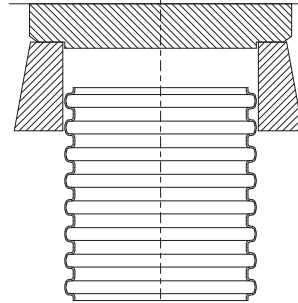

DIAMIR 425

PP cover 425

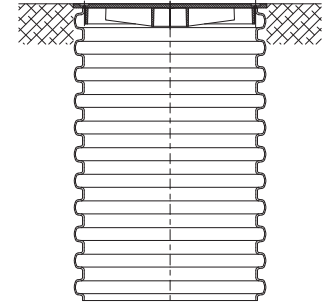

DIAMIR 425

Backdrop manholes

Sometimes it is necessary to connect a channel to a manhole above a base unit. Then, a so called backdrop manhole is constructed. According to standard PN-B-10729 "backdrop manholes in channels of diameters up to 0,40 m and drop height from 0,5 – 4,0 m may be constructed with a backdrop pipe placed inside or outside of a manhole. In a non-entry inspection chamber a drop pipe may be not installed.

That means that for non-entry inspection chambers, if a channel diameter does not exceed 160 mm, connection may be made through a hole in a riser pipe.

Appropriate in-situ gaskets are installed in the hole. If a channel is a K2-Kan structured pipe, a special fitting (adapter to a PVC socket) should be inserted into the in-situ insert. A backdrop pipe is not used. However, if a channel diameter exceeds 200 mm, a backdrop pipe has to be used and it should be connected to a chamber base unit. A T-branch connection is fitted to the channel. One of T-branches is connected to the backdrop pipe and the second (after diameter reduction to 60 mm) is connected to a riser pipe (a hole with an in-situ gasket).

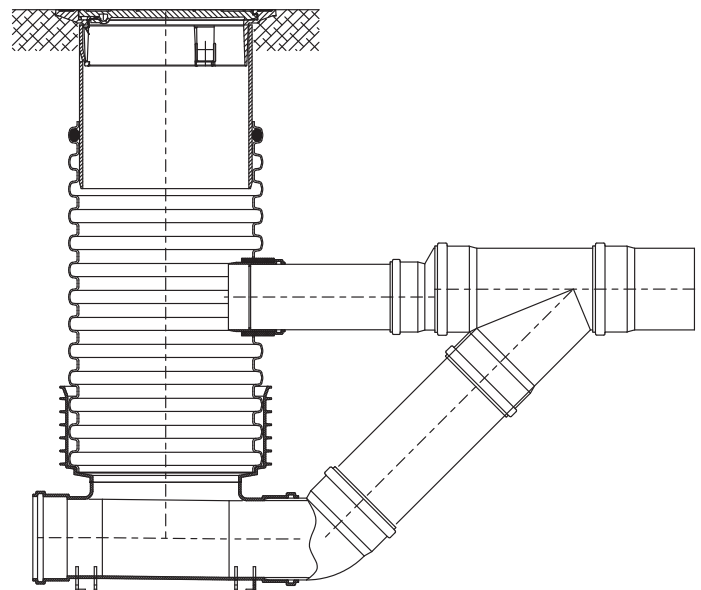
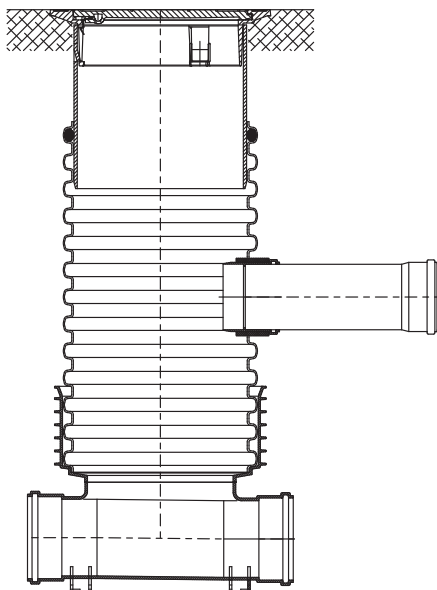

Catch basins with sumps

A catch basin is constructed using a corrugated riser pipe DN 315, 425 or plain wall pipe 400. A pre-blinded pipe of appropriate length should be ordered, it may be also blinded on a building site. A tight basin bottom blinds the pipe. For storm water chambers, a top is a cast iron grating mounted on a telescope pipe. For a drainage chambers all other tops specified in the catalogue of DIAMIR manholes/chambers are applied. They are used depending on the existing loads and investor preferences. In a riser pipe holes are made to construct appropriate outlets or inlets. Appropriate in-situ gaskets should be installed in the holes. In-situ gasket tightness depends on the riser pipe used. See the Declaration of Conformity for details.

In drainage chambers gaskets are mounted in situ and connectors are inserted to drainage pipes.

Note: There are precast drainage and storm water chambers available.

Gully grating 425 D400
500x500

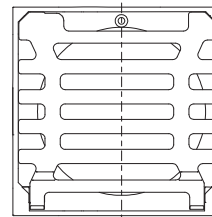

Gully grating 315 D400
420x340

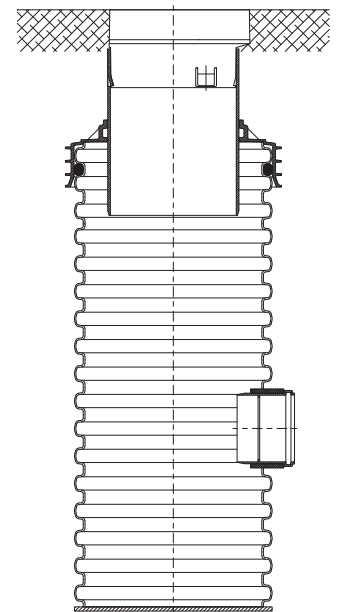
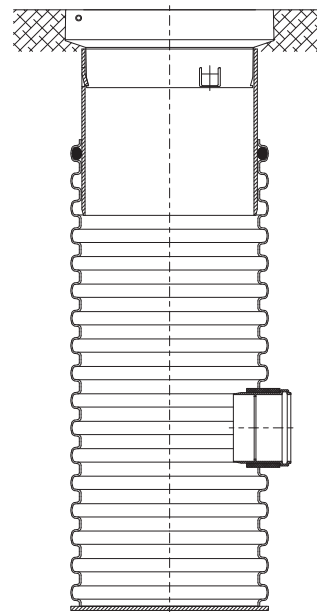
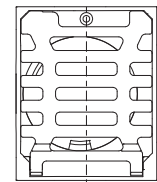

“In situ” gasket installation instructions

Intended use:

-“in-situ” gaskets 110 i 160 are used for connecting plastic pipes to riser pipes of inspection chambers DIAMIR 315, 400, 425, 600, 1000;

-“in-situ” gasket 200 is used for connecting plastic pipes to risers of inspection chambers DIAMIR 600, 1000.



Bore a hole of the required diameter in the chamber riser and then remove remaining burrs.

NOTE! A hole for an in-situ gasket may be made only outside the base unit socket.



Insert the “in-situ” gasket so that an outer flange will adjoin a riser outer wall. The in-situ gasket should be coated with lubricant from inside.



Press in a hub into an “in-situ” gasket to its end. Connect a sewage pipe of an appropriate diameter.

Technical features

Non-entry inspection chambers **DIAMIR 600**

Main components of a chamber

-**base unit, a base of an inspection chamber**, allowing for direct connection of storm water drainage or sanitary sewer systems installed in the ground, including incorporated channels with possible branches along with possible branches

-**a riser, riser pipe** of internal diameter equalling 600

-**a telescope** section, allowing for compensation of settlement which may take place after installation and making it possible to adjust the chamber height A telescope pipe is installed to the depth of 0,8 m below the ground level.

Standards:

-DIAMIR 600 inspection chamber is compliant with

EN 13598-2:2009

EN 476:2011

-approval for use in road ROWs

Technical Approval **IBDiM AT/2010-02-2706**

Technical approval **IK AT/07-2011-0242-00**

Technical Approval **IBDiM AT/2011-02-2706**

-**GIG (Central Mining Institute) Opinion approving their use in the areas** of mining damages up to the 4th category

-Chemical resistance of chamber PP components to chemical substances is compliant with

the ISO/TR 10358 Guidelines

-Gully tops and manhole tops meet the requirements of standard

EN 124:2000

Seals meet the requirements of standard

EN 681-1:2002

-Chemical resistance of elastomeric seals to chemical substances is compliant with

the ISO/TR 7620 Guidelines

Usage:

-maximum installation depth 6 m

-acceptable ground water table 5 m

-acceptable load caused by traffic SLW60 according to ATV-A127P

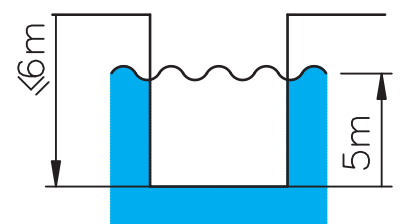

Technical features

Technical data

Base units are made of polypropylene, with reinforcing ribs. They are adapted to connection with vertical riser pipes vertical riser pipes. There is a horizontal channel in the base unit with one or a few inlet connector pipes and one outlet connector pipe ending with bells for connection with plain wall pipes made of PVC-U, PP or PE or connector pipes adapted to connection with structural pipes K2-KAN.

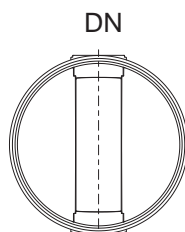

Type 1 0°

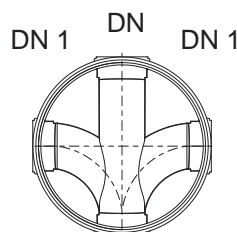

Type 2 90°

Type 1 0°	DN 1	DN	DN 1
DN	DN 1	DN	DN 1
160	160	160	160
200	200	200	200
250	250	250	250
315	315	315	315
400	-	-	-
200K2-Kan	200K2-Kan	200K2-Kan	200K2-Kan
250K2-Kan	250K2-Kan	250K2-Kan	250K2-Kan
300K2-Kan	300K2-Kan	300K2-Kan	300K2-Kan
400K2-Kan	-	-	-

A ball-and-socket joints $\pm 7,5^\circ$ may be used in connection bells 160; 200; 250; 315 (page 28)
 - for other base unit variants consult the manufacturer

Height adjustment

Non-entry inspection chambers DIAMIR 600

Specifications and height adjustment

Preparing specifications for materials required for an investment, total numbers of individual inspection chamber components should be indicated:

-base units, -riser pipes, -tops

The input parameter is chamber height specified in the design – the distance between the ground level and the chamber bottom (base unit level). We label it as **Hs**. In order to make calculations easier, there is useful height (**Hu**) specified for each base unit type, that is, the difference between the bottom of a base unit and the bottom of base unit socket in which a riser pipe is installed. For calculations, we label the height of a riser pipe as **Hw**. The height of a top section (telescope) will be **Ha**. One should bear in mind that the useful height of the telescope must not be smaller than thickness of the structural pavement layer.

No-entry inspection chamber DIAMIR 600

$$H_s = H_u + H_w + H_a$$

$$H_a = H_t + H_z$$

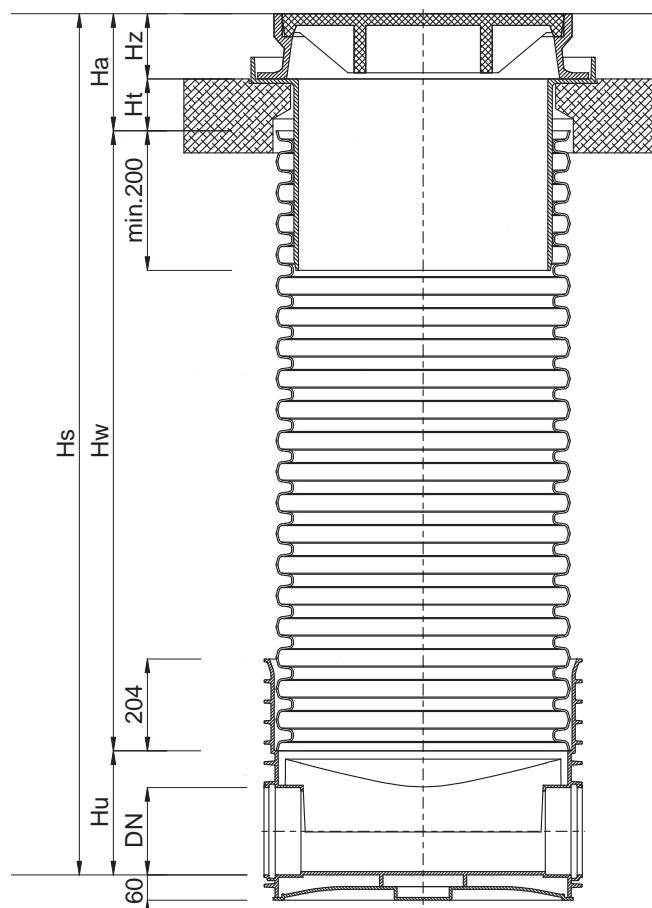

Non-entry inspection chambers DIAMIR 600

Solution options

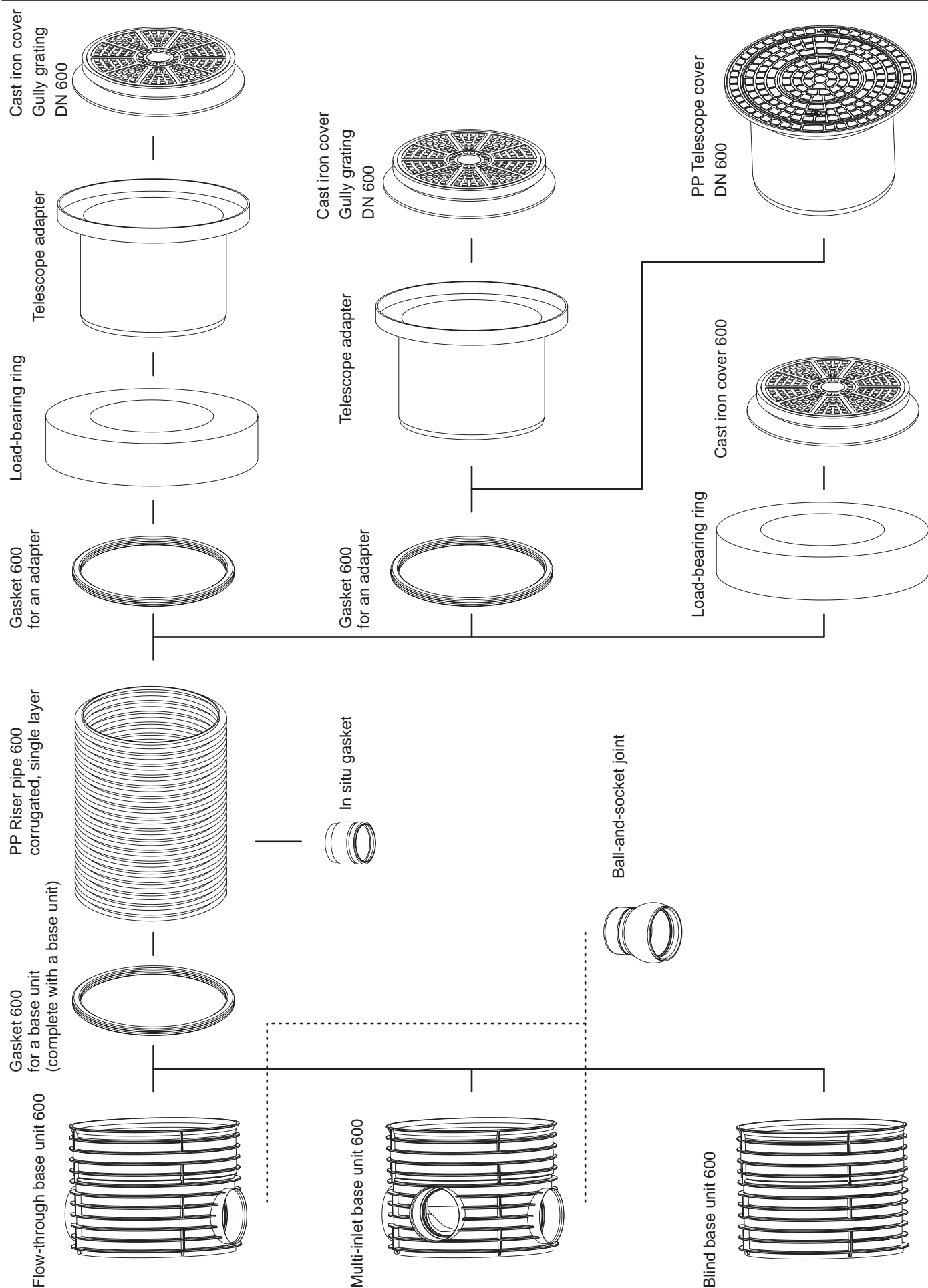

Flow-through base unit 600

with a gasket

Type 1

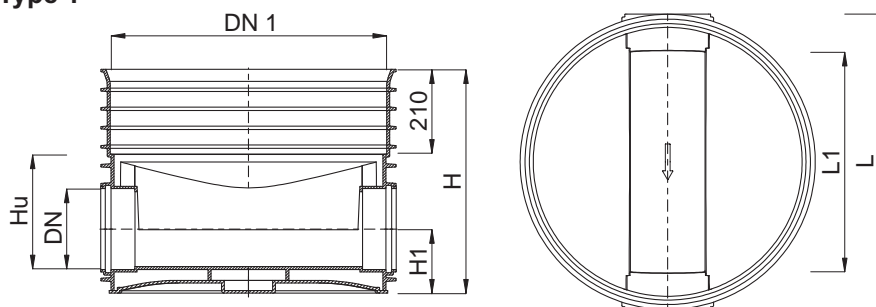

DN [mm]	DN 1 [mm]	H [mm]	Hu [mm]	H1 [mm]	L [mm]	L1 [mm]	Weight [kg]	index -
160	685	556	260	160	732	572	19,1	2581120300
200	685	556	278	160	732	552	21,7	2581130300
250	865	704	378	233	739	508	23,1	2581140300
315	685	704	407	233	739	475	23,6	2581150300
400	685	704	432	248	1218	544	28,2	2581160300
200 K2 *	685	556	278	165	753	552	21,7	2581530300
250 K2 *	685	704	378	240	762	508	23,1	2581540300
300 K2 *	685	704	407	235	778	475	23,6	2581550300
400 K2 *	685	704	432	260	1230	544	29,2	2581560300

* no gaskets in connection sockets

for other base unit variants consult the manufacturer

Multi-inlet base unit

with a gasket

Type 2

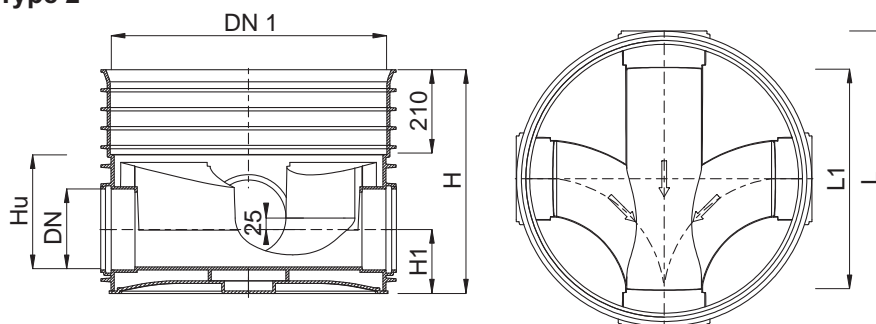

DN [mm]	DN 1 [mm]	H [mm]	Hu [mm]	H1 [mm]	L [mm]	L1 [mm]	Weight [kg]	index -
160	685	556	260	160	732	572	19,7	2582126300
200	685	556	278	160	732	552	21,9	2582136300
250	865	704	378	233	739	508	23,5	2582146300
315	685	704	407	233	739	475	24,3	2582156300
200 K2 *	685	556	278	165	753	552	21,9	2582536300
250 K2 *	685	704	378	240	762	508	23,5	2582546300
300 K2 *	685	704	407	235	778	475	24,3	2582556300

* no gaskets in connection sockets

other base unit variants to be discussed with the manufacturer

Blind base unit 600

with a gasket

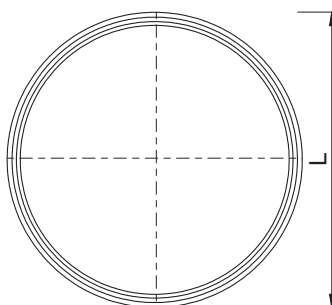
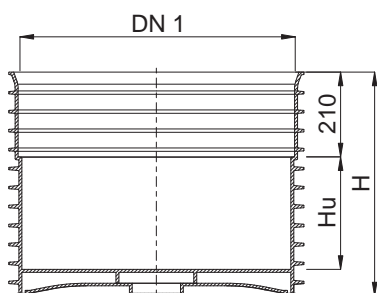

DN [mm]	DN 1 [mm]	H [mm]	Hu [mm]	L [mm]	Weight [kg]	index -
600	685	618	268	732	21,1	2580000300

Single-layer riser pipe 600

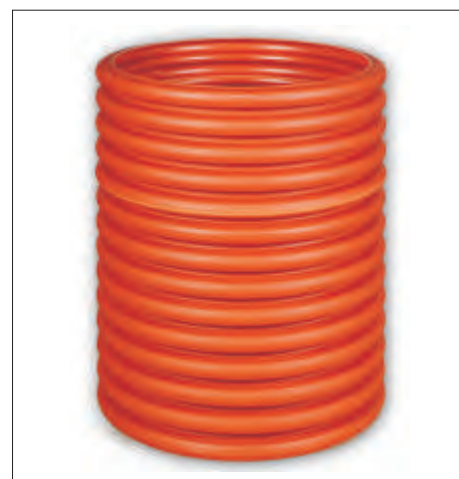
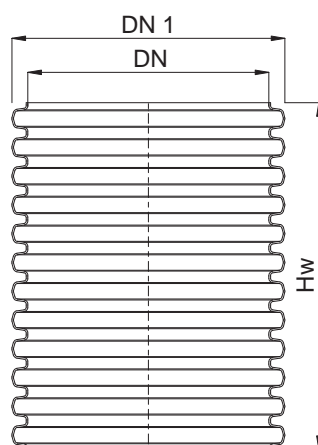

DN [mm]	DN 1 [mm]	Hw [mm]	Weight [kg]	index -
600	683	1000	6,2	2713832100
600	683	2000	12,3	2713832200
600	683	3000	18,9	2713832300
600	683	6000	37,8	2713832600

Gasket 600

for a base unit



Pipe DN 600

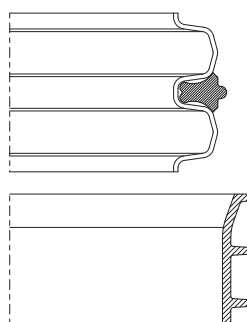

Base unit DN 600



DN [mm]	H [mm]	Weight [kg]	index -
600	35	2,0	5161181010

Telescope adapter 600

with a gasket

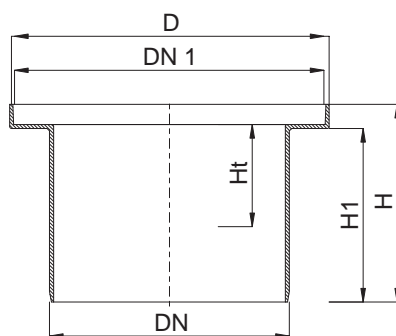

DN [mm]	DN 1 [mm]	D [mm]	H [mm]	H1 [mm]	Ht [mm]	Weight [kg]	index -
600	770	800	490	440	290	9,6	2589120090
600	850	870	490	440	290	10,6	2589140090

PP Telescope cover 600

with a gasket

A15

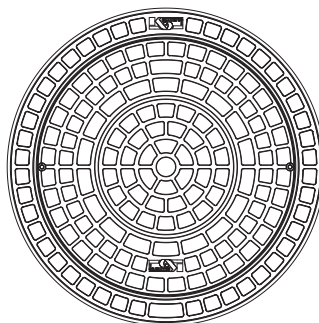
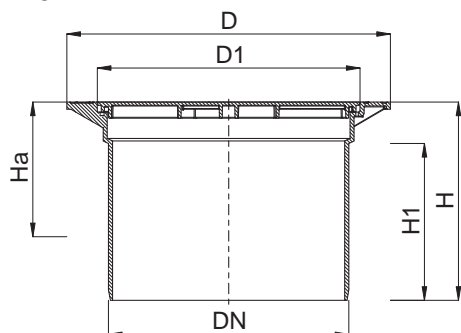

DN [mm]	D [mm]	D1 [mm]	H [mm]	H1 [mm]	Ha [mm]	Weight [kg]	index -
600	800	650	490	390	290	13,9	2589411090

Gasket 600

- for adapter 600

- for PP telescope cover 600

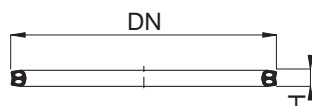

Adapter DN 600

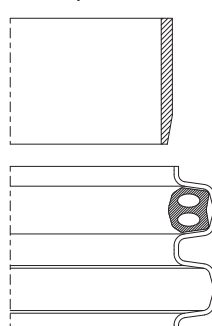

Pipe DN 600



DN [mm]	H [mm]	Weight [kg]	index -
600	40	2,3	5163181010

Load bearing ring 600

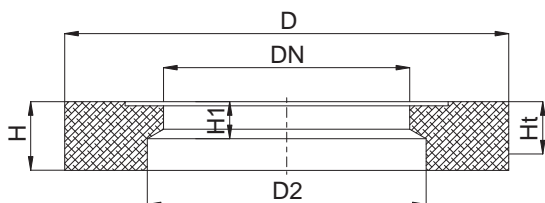

DN [mm]	D [mm]	D2 [mm]	H [mm]	H1 [mm]	Ht [mm]	Weight [kg]	index -
600	1100	690	170	90	120	220,0	2953184000

Cast iron cover 600

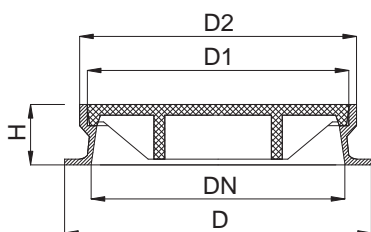

	DN [mm]	DN 1 [mm]	D1 [mm]	D2 [mm]	H [mm]	Weight [kg]	index -
A15	600	680	630	670	50	35,9	2901281500
B125	600	750	640	680	150	103,5	2901282500
C250	600	750	640	680	150	112,0	2901283500
D400	600	760	640	680	150	145,0	2901284500

Gully grating

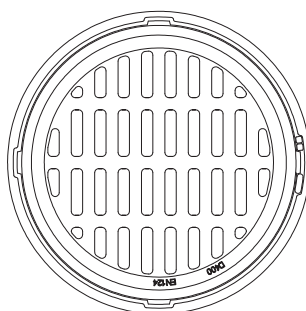
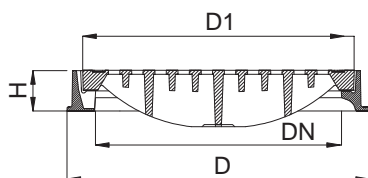

	DN [mm]	DN 1 [mm]	D1 [mm]	H [mm]	Weight [kg]	index -
D400	600	750	680	100	119,0	2902284500

Sewer manhole

with a sedimentation tank for stormwater

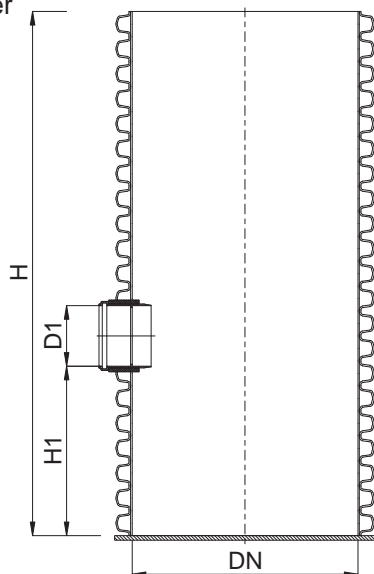

DN	DN 1 [mm]	D1 [mm]	H * [mm]	H1 [mm]	Weight [kg]	index -
600	683	160	2000	500	40,9	2818120200
600	683	200	2000	500	41,7	2818130200

* other manhole heights available on request

"In situ" gasket

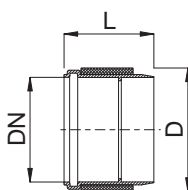

DN	D1 [mm]	L [mm]	Weight [kg]	index -
110	138	120	0,5	5168201010
160	177	120	0,8	5168231010
200	226	120	1,6	5168251010

Hole cutter

Cutter holder – all-purpose

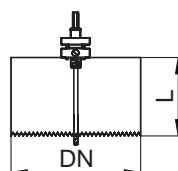

DN	D1 [mm]	L [mm]	Weight [kg]	index
110	138	90	0,8	5191201100
160	177	90	1,2	5191231100
200	226	90	1,7	5191252100
uniwersalny	-	-	0,6	5191000100

Installation instructions

DIAMIR inspection chambers should be installed in conditions specified in the technical design. The ground around chambers (0,3 m) should be composed of compactable soil, approved for use in road construction according to standard PN-S-02205:1998. Earthworks should be carried out in accordance with standard PN-EN 1610: 2002/Ap1:2007. Soil compaction should be performed in layers as specified in standard PN-ENV 1046:2007 to prevent from excessive ovalisation of a chamber cross-section.



1 Prepare a trench in an inspection chamber location removing large and sharp-edged stones. On the trench bottom prepare bedding composed of compactable soil, preferably sand (coarse- medium- or fine-grained) of minimum 10 cm thickness. An inspection chamber zone should include an area of at least a 30 cm wide strip around the chamber.



2 Place a base unit on a prepared earlier sand bedding and level it and then connect sewage pipes to the chamber.



3 Fill up the trench with preliminary backfill (10 cm above the pipe level). Compaction should be performed manually, in layers every 15 cm or with light mechanical equipment (each layer up to 30 cm). Base unit socket 600 should protrude above the backfill level.



4 Prepare a corrugated riser pipe of the required length. The pipe can be cut to the required chamber height. Install a gasket in the lowest groove on the outside of the riser pipe. The gasket is delivered along with a base unit.



5 Lubricant should be applied on the inner side of a base unit socket 600 and gasket. Products approved for rubber gaskets and plastic should be used.

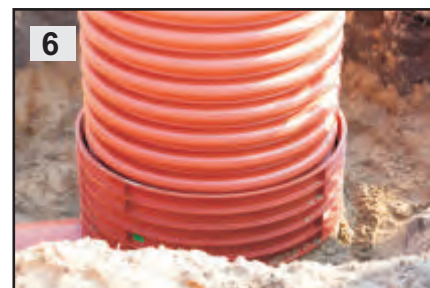

6 Insert a riser pipe with an installed gasket 600 into a base unit.



7 Compact the area around the pipe. Compaction should be performed manually, in layers every 15 cm or with light mechanical equipment (each layer up to 30 cm) in open areas to at least 90% of the Proctor compaction test and for inspection chambers located in a carriageway or road shoulder backfill should meet the requirements specified for compaction index resulting from the installation depth, road construction type (cutting, embankment) or traffic intensity category.



8 For inspection chambers equipped with riser pipes connected with telescope pipes with a cuff gasket, ensure a telescope pipe is inserted into a riser pipe to the depth of approximately 20 cm.

Chamber tops

Location of a DIAMIR chamber and expected load caused by traffic are the basis for selection of riser and telescope pipe stiffness and a choice of cast iron covers.

Depending on the chamber location within a ROW and a traffic intensity category, different manhole/gully tops are used, also construction requirements and top type which are classified into the following groups may differ.

Group 1 - Class A15 - green areas intended solely for pedestrians and pedal cyclists

Group 2 - Class B125 - Roads and areas for pedestrians, and comparable areas, parking lots or places where cars are parked

Group 3 - Class C250 - Applies solely do sewer gully tops installed in the area of kerbside channels of roads and road shoulders

Group 4 - Class D400 - Carriageways of roads (including pedestrian streets) hard shoulders, and parking areas for all types of road vehicles

There are different rules of the manhole/gully top support depending on their type and class, and soil conditions. A manhole/gully top should sit on a reinforced concrete slab which is supported by an appropriately constructed load bearing structure adapted to loads caused by traffic. That may be reinforced bedding made of well compacted soil or a precast load-relieving slab made of reinforced concrete. For very heavy load caused by traffic or doubts about compaction of soil constituting top base, a slab should be based on B30 concrete ring of minimum height of 20 cm cast on the building site

Cast iron chamber cover 600
Telescope adapter 600
Load bearing concrete ring 600

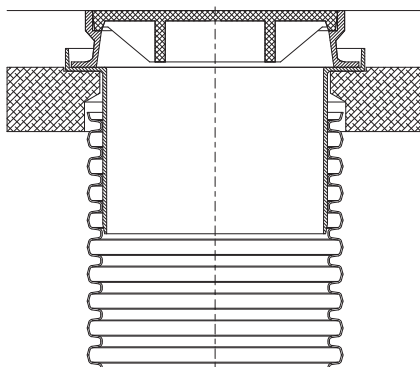

Cast iron chamber cover 600
Load bearing concrete ring 600

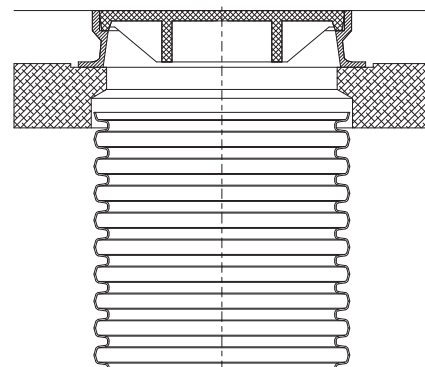

Cast iron chamber cover 600
Telescope adapter 600

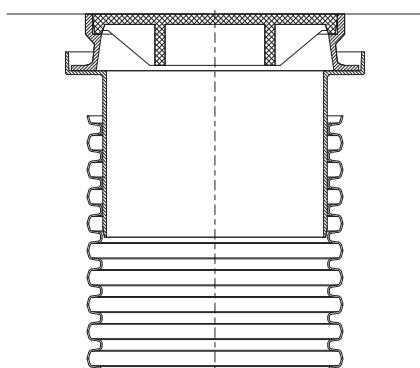

PP Telescope cover 600

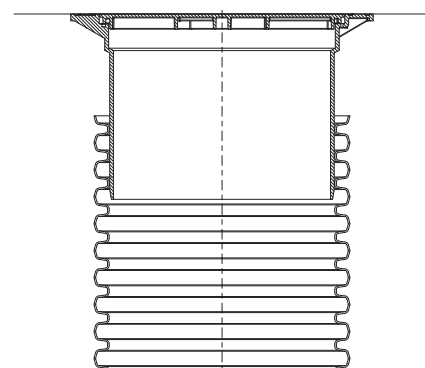

Catch basins 600

A catch basin is constructed using a corrugated riser pipe DN 315, 425 or plain wall pipe 400. A pre-blinded pipe of appropriate length should be ordered, it may be also blinded on a building site. A tight basin bottom blinds the pipe. For stormwater chambers, a top is a cast iron grating mounted on a telescope pipe. For a drainage chambers all other tops specified in the catalogue of DIAMIR manholes/chambers are applied. They are used depending on the existing loads and investor preferences. In a riser pipe holes are made to construct appropriate outlets or inlets. Appropriate in-situ gasket should be installed in the holes. Insert in-situ gasket depends on the riser pipe used (single- or double-layer). See the Declaration of Conformity for details. In drainage chambers gaskets are mounted in situ and connectors are inserted to drainage pipes.

Note: There are precast drainage and storm water chambers available.

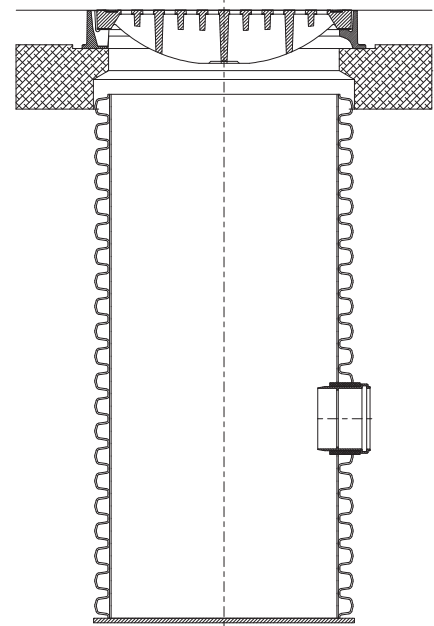

Backdrop manholes

Sometimes it is necessary to connect a channel to a manhole above a base unit.

Then, a so called backdrop manhole is constructed. According to standard PN-B-10729 "backdrop manholes in channels of diameters up to 0.40 m and drop height from 0,5 - 4,0 m may be constructed with a backdrop pipe placed inside or outside of a manhole. In a non-entry inspection chamber a drop pipe may be not installed.

That means that for non-entry inspection chambers, if a channel diameter does not exceed 160 mm, connection may be made through a hole in a riser pipe.

Appropriate in-situ gaskets are installed in the hole. If a channel is a K2-Kan structured pipe, a special fitting (adapter to a PVC socket) should be inserted into the in situ gasket. A backdrop pipe is not used. However, if a channel diameter exceeds 200 mm, a backdrop pipe has to be used and it should be connected to a chamber base unit. A T-branch connection is fitted to the channel. One of T-branches is connected to the backdrop pipe and the second one (after diameter reduction to 60 mm) is connected to a riser pipe (hole with an in situ gasket).

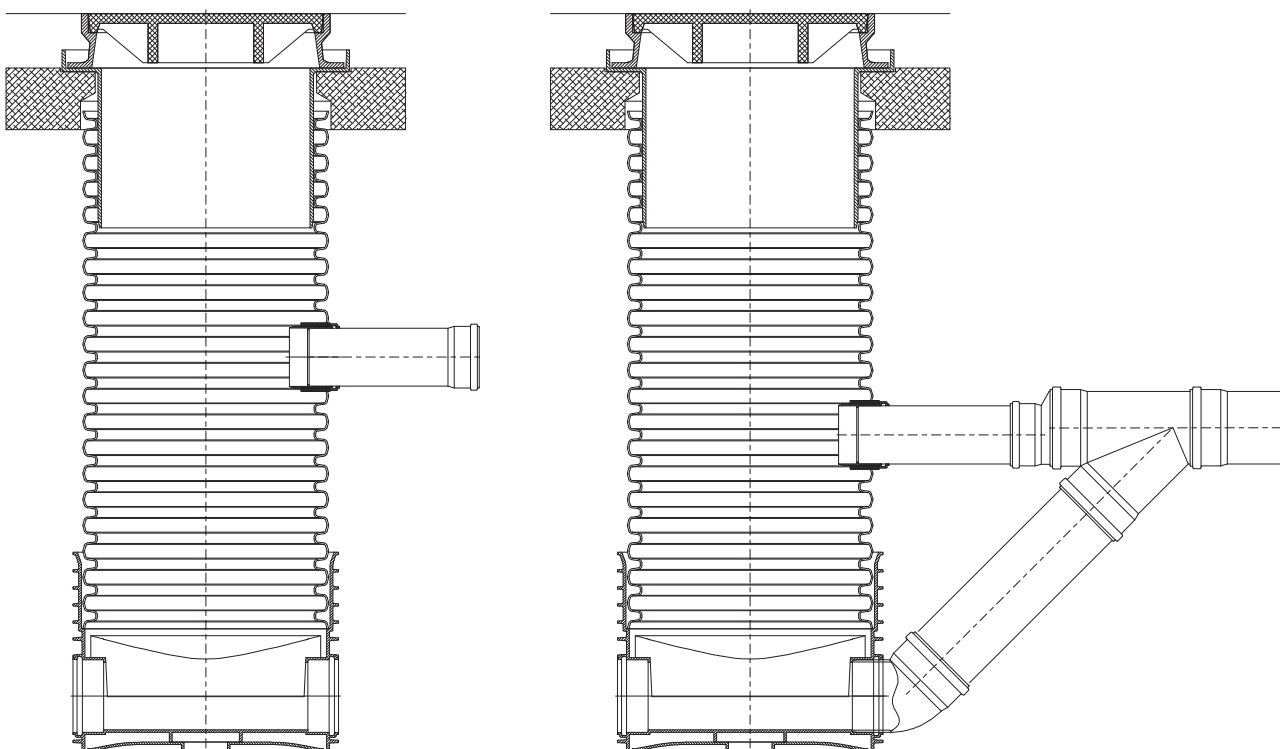

Technical features

Entry manholes **DIAMIR 1000**

Main components of a chamber

-**base unit, a base of an entry manhole**, allowing for direct connection of storm water drainage or sanitary sewer systems installed in the ground, including incorporated channels with possible branches along with possible branches

-**shaft, a chamber built of modular PP sections**, of the internal diameter 1000, equipped with access steps

-**reduction cone PP 1000/600** allowing for adjustment of the manhole height. The cone is equipped with access steps



Standards:

-DIAMIR 1000 inspection chamber is compliant with
PN-EN 13598-2:2009

PN-EN 476:2011

-approval for use in road ROWs

Technical Approval **IBDIM AT/2010-02-2830**

Technical approval **IK AT/07-2011-0242-00**

Technical Approval **IBDIM AT/2011-02-2706**

-**GIG (Central Mining Institute) Opinion approving their use in the areas** of mining damages up to the 4th category

-Chemical resistance of chamber PP components to chemical substances is compliant with

the ISO/TR 10358 Guidelines

-Gully tops and manhole tops meet the requirements of standard

PN-EN 124:2000

-manhole steps meet the requirements of standard

PN-EN 13101:2005

-Seals meet the requirements of standard

PN-EN 681-1:2002

-Chemical resistance of elastomeric seals to chemical substances is compliant with

the ISO/TR 7620 Guidelines

Usage:

-maximum installation depth 6 m

-acceptable ground water table 5 m

-acceptable load caused by traffic SLW60 according to ATV-A127P

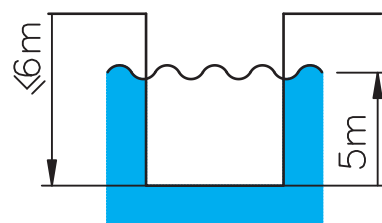

Technical features

Technical data

Base units are made of polypropylene, with reinforcing ribs. They are adapted to connection with vertical riser pipes. There is a horizontal channel in the base unit with one or a few inlet connector pipes and one outlet connector pipe ending with bells for connection with plain wall pipes made of PVC-U, PP or PE or connector pipes adapted to connection with structural pipes K2-KAN.

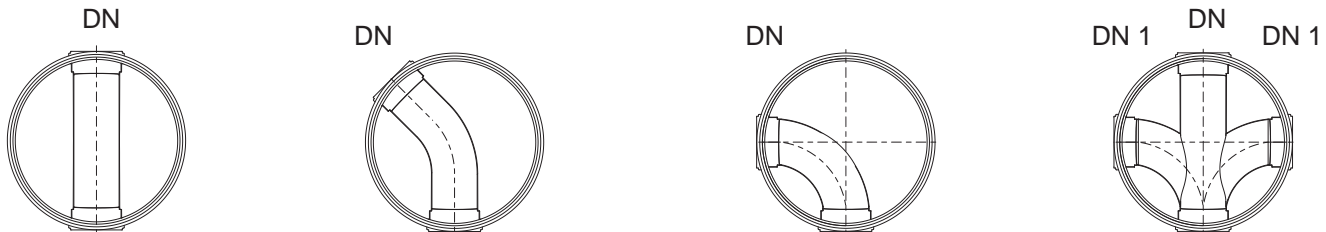

Type 1 0°	Type 1 15°	Type 1 30°	Type 1 45°	Type 1 90°	Type 2 45° 90°		
DN	DN	DN	DN	DN	DN 1	DN	DN 1
200	200	200	200	200	200	200	200
250	250	250	250	250	250	250	250
315	315	315	315	315	315	315	315
400	400	400	400	400	400	400	400
500	500	500	500	-	-	-	-
200K2-Kan	200K2-Kan	200K2-Kan	200K2-Kan	200K2-Kan	200K2-Kan	200K2-Kan	200K2-Kan
250K2-Kan	250K2-Kan	250K2-Kan	250K2-Kan	250K2-Kan	250K2-Kan	250K2-Kan	250K2-Kan
300K2-Kan	300K2-Kan	300K2-Kan	300K2-Kan	300K2-Kan	300K2-Kan	300K2-Kan	300K2-Kan
400K2-Kan	400K2-Kan	400K2-Kan	400K2-Kan	400K2-Kan	400K2-Kan	400K2-Kan	400K2-Kan
500K2-Kan	500K2-Kan	500K2-Kan	500K2-Kan	-	-	-	-
600K2-Kan	600K2-Kan	600K2-Kan	-	-	-	-	-

A ball-and-socket joints $\pm 7,5^\circ$ may be used in connection bells 160; 200; 250; 315 (page 28)

Height adjustment

Entry manholes DIAMIR 1000

Specifications and height adjustment

Preparing specifications for materials required for an investment, total numbers of individual inspection chamber components should be indicated:

-base units, -riser pipes, -tops

The input parameter is chamber height specified in the design – the distance between the ground level and the chamber invert (base unit level). We label it as **Hs**.

In order to make calculations easier, there is useful height (**Hu**) specified for each base unit type, that is, the distance between the bottom of a base unit and the bottom of base unit bell in which a riser pipe is installed.

For calculations, we label the height of vertical chamber sections as **Hw**. Taper height will be **Hst**. The effective height of a top section (telescope) will be **Ha**.

Entry manhole DIAMIR 1000

$$H_s = H_u + H_w + H_{st} + H_a$$

$$H_a = H_t + H_z$$

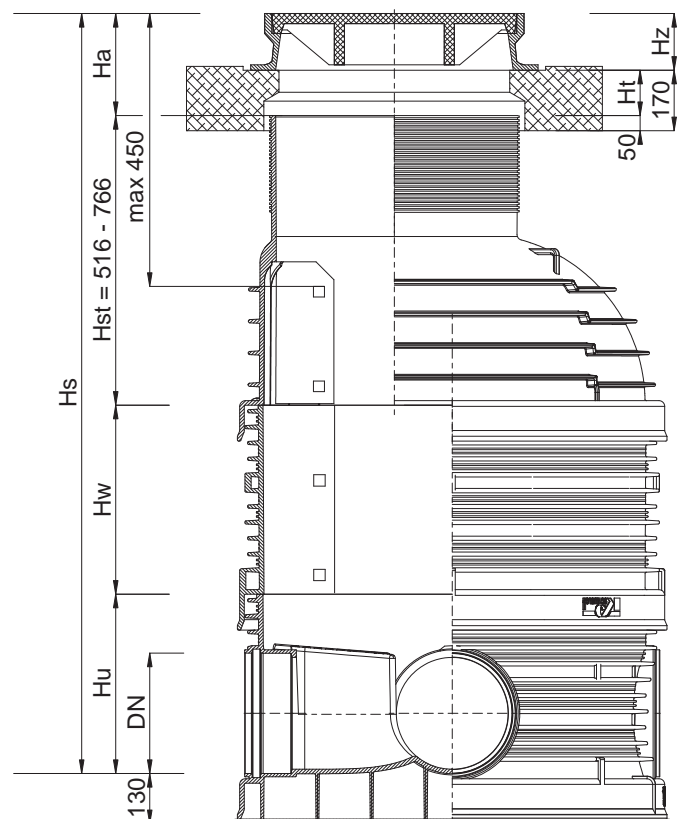

Entry manholes DIAMIR 1000

Solution options

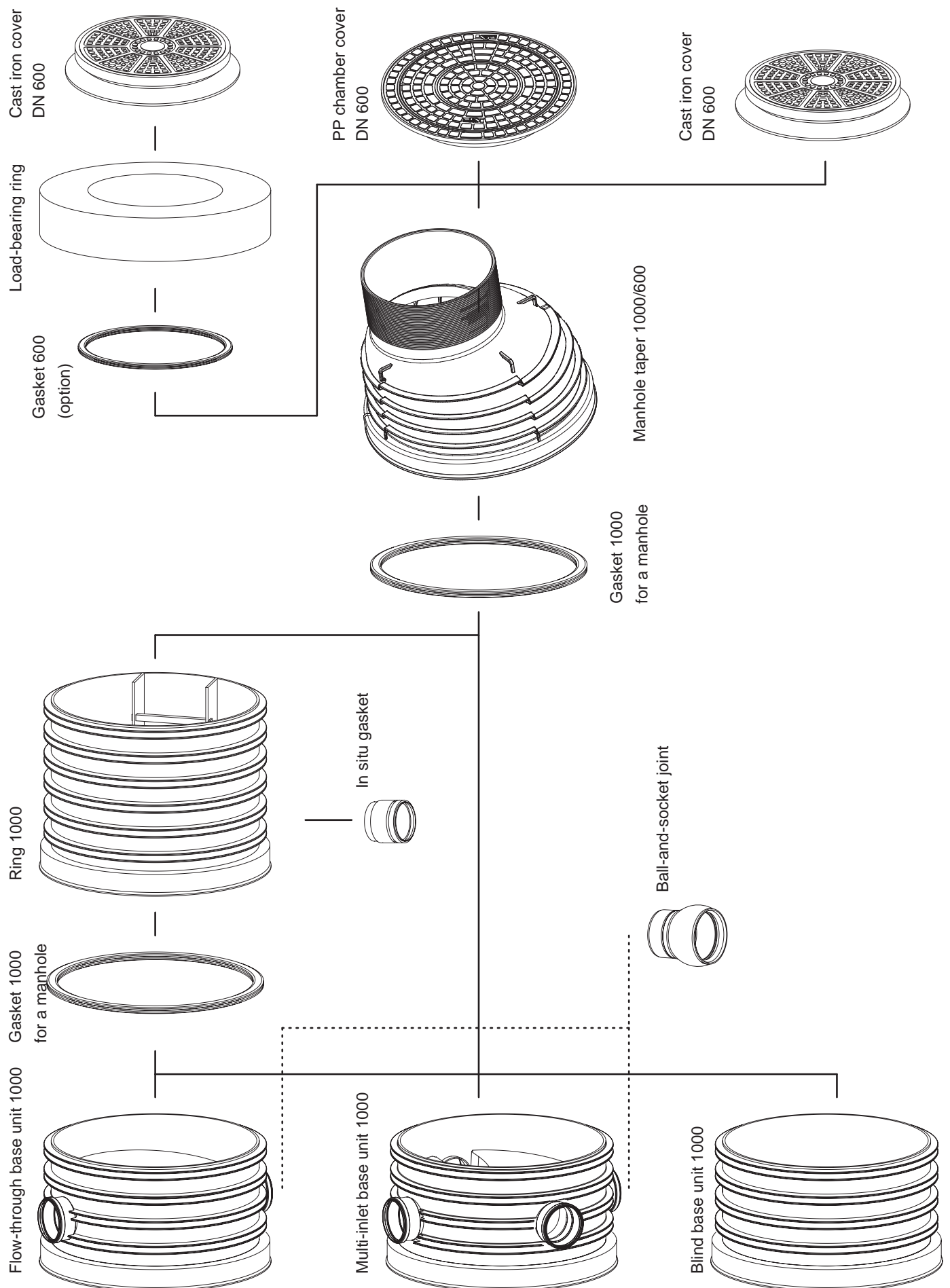

Flow-through base unit 1000

Type 1

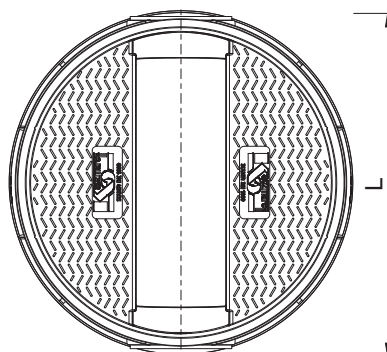
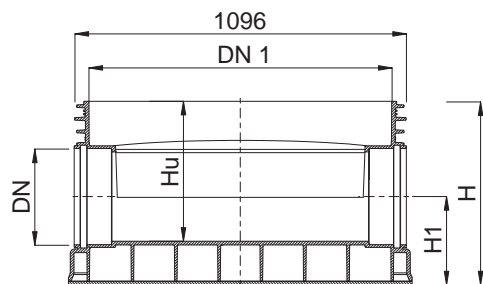

DN [mm]	DN 1 [mm]	H [mm]	Hu [mm]	H1 [mm]	L [mm]	Weight [kg]	index -
200	1000	595	444	252	1136	73,4	2631130030
250	1000	595	460	260	1136	76,4	2631140030
315	1000	595	475	280	1136	76,4	2631150030
400	1000	595	496	300	1440	91,6	2631160030
500	1000	845	665	440	1496	94,5	2631170030
200 K2 *	1000	595	438	259	1230	73,4	2631530030
250 K2 *	1000	595	432	291	1272	76,4	2631540030
300 K2 *	1000	595	435	320	1320	76,4	2631550030
400 K2 *	1000	595	495	382	1430	93,1	2631560030
500 K2 *	1000	845	658	440	1516	94,8	2631570030
600 K2 *	1000	845	665	498	1576	123,5	2631580030

* no gaskets in connection bells

Flow-through base unit 1000

Type 1

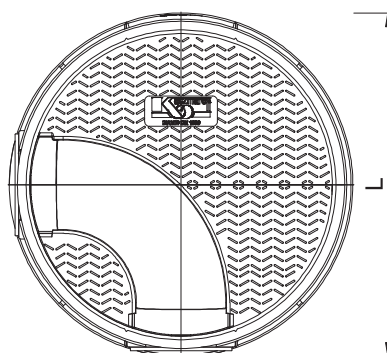
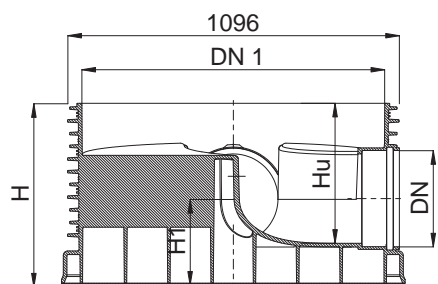

DN [mm]	DN 1 [mm]	H [mm]	Hu [mm]	H1 [mm]	L [mm]	Weight [kg]	index -
200x90°	1000	595	444	252	1136	73,8	2631139030
250x90°	1000	595	460	260	1136	76,8	2631149030
315x90°	1000	595	475	280	1136	76,4	2631159030
400x90°	1000	595	496	300	1440	91,6	2631169030
200K2-90° *	1000	595	444	252	1136	52,2	2631539030
250K2-90° *	1000	595	460	260	1136	55,0	2631549030
300K2-90° *	1000	595	475	280	1136	57,5	2631559030
400K2-90° *	1000	595	496	300	1440	91,6	2631569030

* no gaskets in connection bells

Flow-through base unit 1000

Type 1

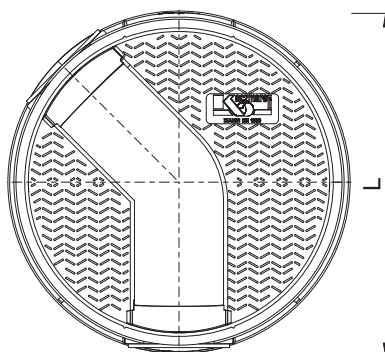
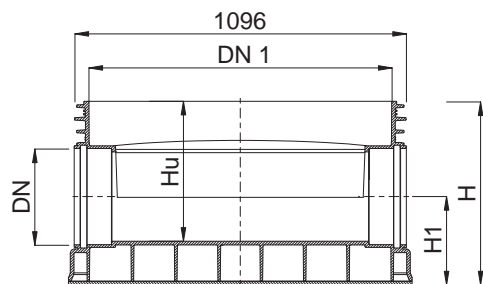

DN [mm]	DN 1 [mm]	H [mm]	Hu [mm]	H1 [mm]	L [mm]	Weight [kg]	index -
200x15°	1000	595	444	252	1136	73,8	2631131530
250x15°	1000	595	460	260	1136	76,8	2631141530
315x15°	1000	595	475	280	1136	76,4	2631151530
400x15°	1000	595	496	300	1440	91,6	2631161530
500x15°	1000	845	665	440	1496	94,5	2631161530
200K2-15°*	1000	595	444	252	1136	52,2	2631531530
250K2-15°*	1000	595	460	260	1136	55,0	2631541530
300K2-15°*	1000	595	475	280	1136	57,5	2631551530
400K2-15°*	1000	595	496	300	1440	91,6	2631561530
500K2-15°*	1000	845	658	440	1430	94,8	2631561530
600K2-15°*	1000	845	665	498	1516	123,5	2631561530
200x30°	1000	595	444	252	1136	73,8	2631133030
250x30°	1000	595	460	260	1136	76,8	2631143030
315x30°	1000	595	475	280	1136	76,4	2631153030
400x30°	1000	595	496	300	1440	91,6	2631163030
500x30°	1000	845	665	440	1496	94,5	2631163030
200K2-30°*	1000	595	444	252	1136	52,2	2631533030
250K2-30°*	1000	595	460	260	1136	55,0	2631543030
300K2-30°*	1000	595	475	280	1136	57,5	2631553030
400K2-30°*	1000	595	496	300	1440	91,6	2631563030
500K2-30°*	1000	845	658	440	1430	94,8	2631563030
600K2-30°*	1000	845	665	498	1516	123,5	2631563030
200x45°	1000	595	444	252	1136	73,8	2631134530
250x45°	1000	595	460	260	1136	76,8	2631144530
315x45°	1000	595	475	280	1136	76,4	2631154530
400x45°	1000	595	496	300	1440	91,6	2631164530
500x45°	1000	845	665	440	1496	94,5	2631164530
200K2-45°*	1000	595	444	252	1136	52,2	2631534530
250K2-45°*	1000	595	460	260	1136	55,0	2631544530
300K2-45°*	1000	595	475	280	1136	57,5	2631554530
400K2-45°*	1000	595	496	300	1440	91,6	2631564530
500K2-45°*	1000	845	658	440	1430	94,8	2631564530

* no gaskets in connection bells

Multi-inlet base unit 1000

Type 2

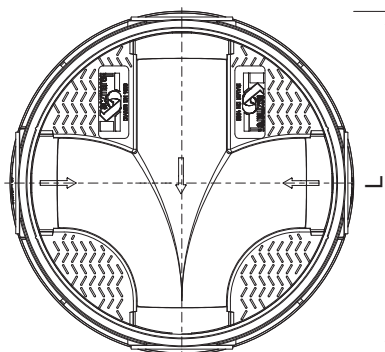
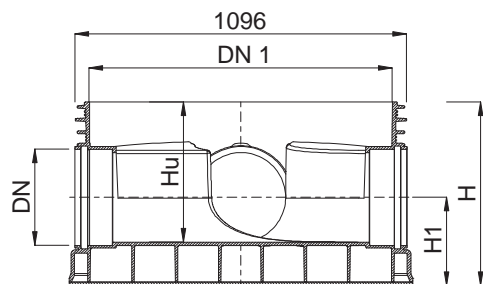

DN [mm]	DN 1 [mm]	H [mm]	Hu [mm]	H1 [mm]	L [mm]	Weight [kg]	index -
200	1000	595	444	252	1136	52,9	2632139030
250	1000	595	460	260	1136	56,3	2632149030
315	1000	595	475	280	1136	59,3	2632159030
400	1000	595	496	300	1440	95,6	2632169030
500	1000	845	705	440	1496	101,3	2632179030
200 K2 *	1000	595	438	259	1230	53,3	2632539030
250 K2 *	1000	595	432	291	1272	57,1	2632549030
300 K2 *	1000	595	435	320	1320	60,2	2632559030
400 K2 *	1000	595	495	382	1430	97,7	2632569030
500 K2 *	1000	845	705	440	1516	103,4	2632579030

* no gaskets in connection bells

Blind base unit 1000

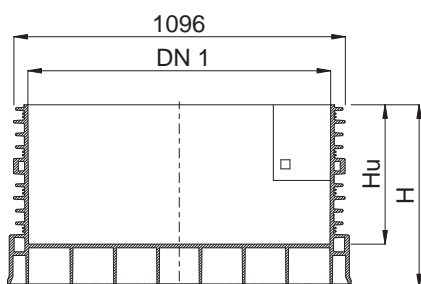

DN 1 [mm]	H [mm]	Hu [mm]	Weight [kg]	index -
1000	595	480	66,0	2630040030
1000	1095	980	82,5	2630080030

Ring 1000

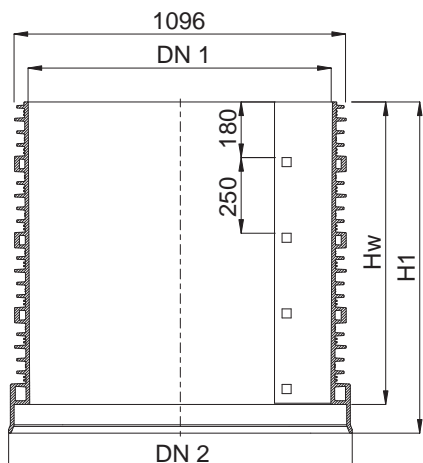

Hw [mm]	H1 [mm]	DN 1 [mm]	DN 2 [mm]	Weight [kg]	index -
250	345	1000	1136	21,0	2639120030
500	595	1000	1136	36,0	2639140030
750	845	1000	1136	52,5	2639160030
1000	1095	1000	1136	68,0	2639180030

Manhole gasket 1000

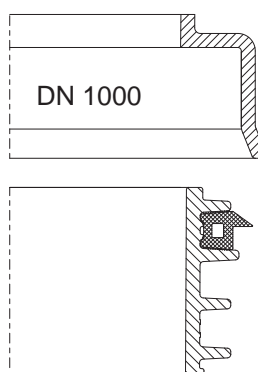
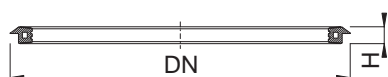

DN [mm]	H [mm]	Weight [kg]	index -
1000	30	3,8	5161231010

Manhole taper 1000

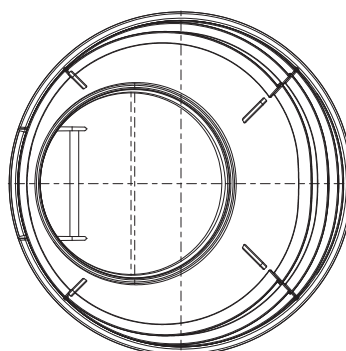
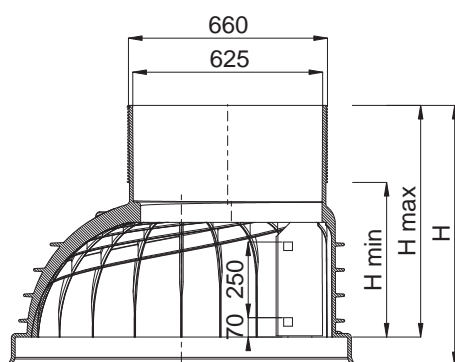

DN [mm]	DN 2 [mm]	H min [mm]	H max [mm]	H [mm]	Weight [kg]	index -
1000/625	1100	516	766	861	43,0	2639220030

Manhole gasket 1000/600 for a manhole taper



Load-bearing ring

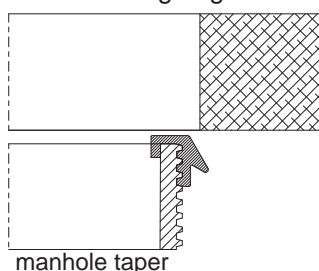

DN [mm]	H [mm]	Weight [kg]	index -
1000	30	2,1	5164181010

Load-bearing ring

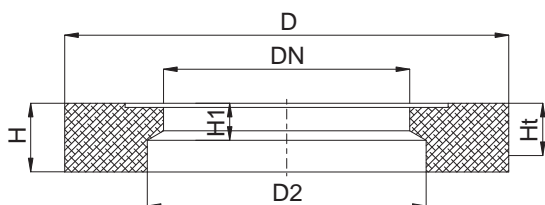

DN [mm]	D [mm]	D2 [mm]	H [mm]	H1 [mm]	Ht [mm]	Weight [kg]	index -
600	1100	690	170	90	120	220,0	2953184000

PP chamber cover DN 600

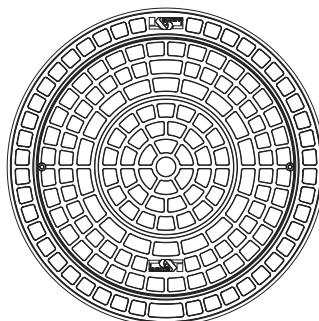
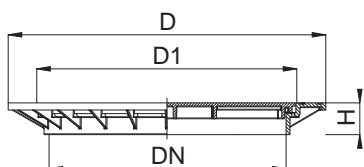

	DN [mm]	D [mm]	D1 [mm]	H [mm]	Weight [kg]	index -
A15	600	800	650	80	8,4	2589421090

Cast iron chamber cover DN 600

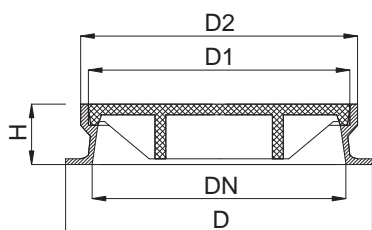

	DN [mm]	DN 1 [mm]	D1 [mm]	D2 [mm]	H [mm]	Weight [kg]	index -
A15	600	680	630	670	50	35,9	2901281500
B125	600	750	640	680	150	103,5	2901282500
C250	600	750	640	680	150	112,0	2901283500
D400	600	760	640	680	150	145,0	2901284500
D400 Gully grating	600	750	680	710	100	119,0	2902284500

Installation instructions

DIAMIR inspection chambers should be installed in conditions specified in the technical design. The ground around chambers (0,3 m) should be composed of compactable soil, approved for use in road construction according to standard PN-S-02205:1998. Earthworks should be carried out in accordance with standard PN-EN 1610:2002/Ap1:2007. Soil compaction should be performed in layers as specified in standard PN-ENV 1046:2007 to prevent from excessive ovalisation of a chamber cross-section.



1 Prepare a trench in an inspection chamber location removing large and sharp-edged stones. On the trench bottom prepare bedding composed of compactable soil, preferably sand (coarse- medium- or fine-grained) of minimum 10 cm thickness. An inspection chamber zone should include an area of at least a 30 cm wide strip around the chamber.



2 Place a base unit on a prepared earlier sand bedding and level it and then connect sewage pipes to the chamber. A place where a manhole is located should be lowered by approximately 10 cm. Connect sewage pipes.



3 Fill up the trench with preliminary backfill (10 cm above the pipe level). Compaction should be performed manually, in layers every 15 cm or with light mechanical equipment (each layer up to 30 cm). Base unit 1000 should protrude above the backfill level.

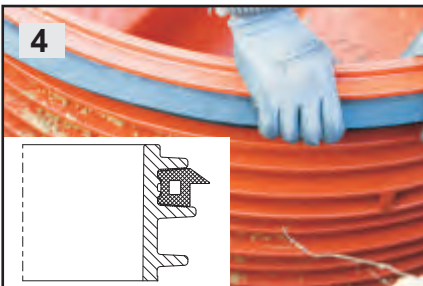

4 Install a gasket $\varnothing 1000$ in the lowest groove on the outside of the ring. The groove should be thoroughly cleaned before gasket installation.



5 Lubricant should be applied onto a gasket $\varnothing 1000$ before jointing with another manhole section. Products approved for rubber gaskets and plastic should be used. Note! If there are no rings of diversified heights on a building site, rings of standard heights may be cut. Rings may be cut only at marked places every 25 cm.

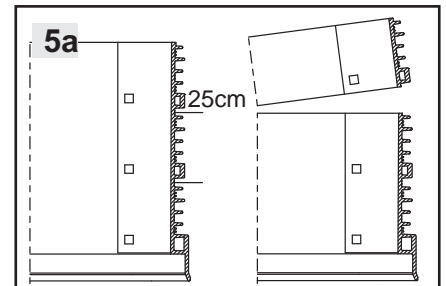

6 A taper should be installed similarly to other manhole components (rings $\varnothing 1000$). A cylindrical section of the taper (from the minimum of 1 to the maximum of 25 cm) may be cut to achieve the required manhole height.

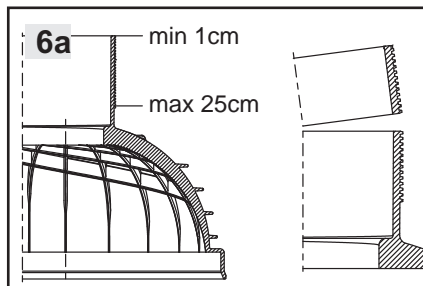

7 For shallow installations, taper 1000/600 may be connected directly to a base unit with no ring used.

Note! A gasket may be installed in the cylindrical taper section (between the taper and a concrete ring).

Installation instructions



Compact the area around the pipe. Compaction should be performed manually, in layers every 15 cm or with light mechanical equipment (each layer up to 30 cm) in open areas to at least 90% of the Proctor compaction test and for inspection chambers located in a carriageway or road shoulder backfill should meet the requirements specified for compaction index resulting from the installation depth, road construction type (cutting, embankment) or traffic intensity category.

The manhole cover should be secured against shifting by means of anchoring or concreting.

Manhole tops

Location of a DIAMIR 1000 manhole and expected load caused by traffic are the basis for selection of riser and telescope pipe stiffness and a choice of cast iron covers.

Depending on the chamber location within a ROW and a traffic intensity category, different manhole/gully tops are used, also construction requirements and top type which are classified into the following groups may differ.

Group 1 - Class A15 - green areas intended solely for pedestrians and pedal cyclists

Group 2 - Class B125 - Roads and areas for pedestrians, and comparable areas, parking lots or places where cars are parked

Group 3 - Class C250 - Applies solely do sewer gully tops installed in the area of kerbside channels of roads and road shoulders

Group 4 - Class D400 - Carriageways of roads (including pedestrian streets) hard shoulders, and parking areas for all types of road vehicles

There are different rules of the manhole/gully top support depending on their type and class, and soil conditions. A manhole/gully top should sit on a reinforced concrete slab which is supported by an appropriately constructed load bearing structure adapted to loads caused by traffic. That may be reinforced bedding made of well compacted soil or a precast load-relieving slab made of reinforced concrete. For very heavy load caused by traffic or doubts about compaction of soil constituting the top base, a slab should be based on B30 concrete ring of minimum height of 20 cm cast on a building site

PP chamber cover DN 600

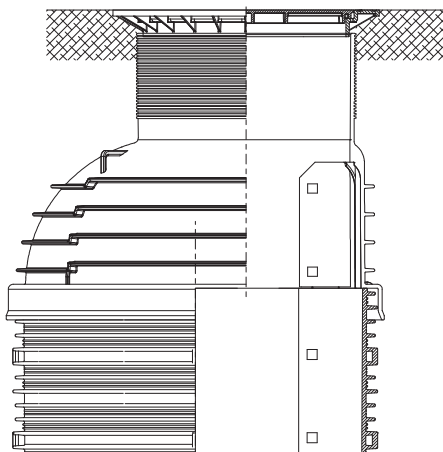

Cast iron cover DN 600

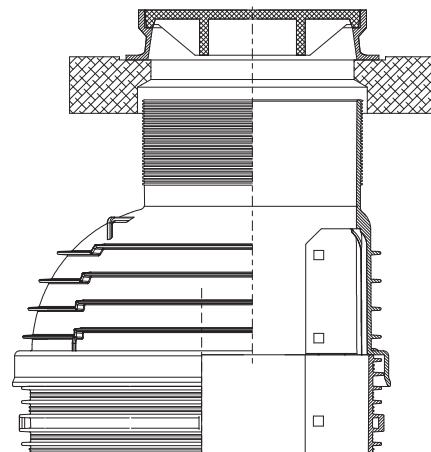

Backdrop manholes

Sometimes it is necessary to connect a channel to a manhole above a base unit.

Then, a so called backdrop manhole is constructed. According to standard PN-B-10729 "backdrop manholes in channels of diameters up to 0,40 m and drop height from 0,5 - 4,0 m may be constructed with a backdrop pipe placed inside or outside of a manhole. In a non-entry inspection chamber a drop pipe may be not installed.

That means that for non-entry inspection chambers, if a channel diameter does not exceed 160 mm, connection may be made through a hole in a riser pipe.

Appropriate in-situ gaskets are installed in the hole. If a channel is a K2-Kan structured pipe, a special fitting (adapter to a PVC socket) should be inserted into the in-situ gasket. A backdrop pipe is not used. However, if a channel diameter exceeds 200 mm, a backdrop pipe has to be used and it should be connected to a chamber base unit. A T-branch connection is fitted to the channel. One of T-connections is connected to the backdrop pipe and the second (after diameter reduction to 60 mm) is connected to a riser pipe (hole with an in-situ gasket).

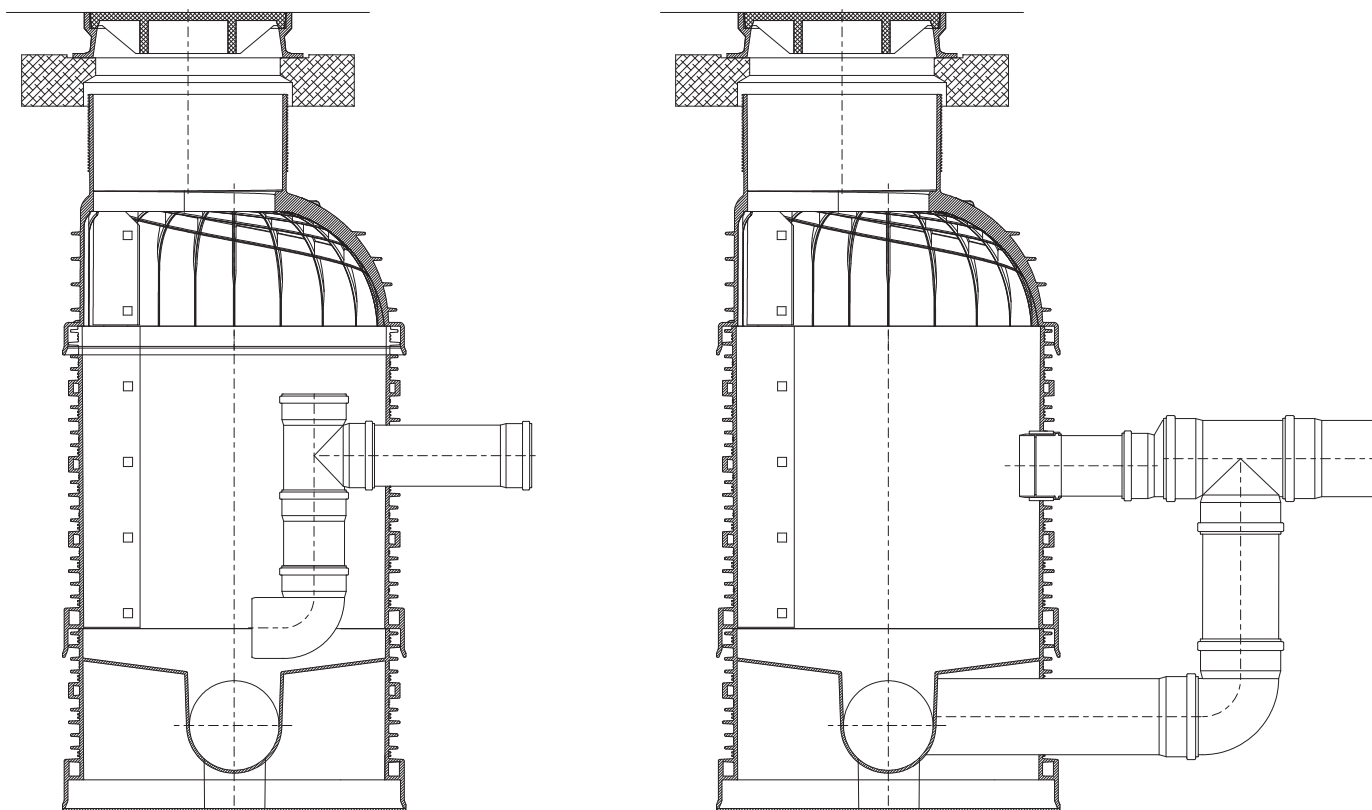

Special manhole/inspection chambers **DIAMIR**

Sewer manholes/inspection chambers **DIAMIR** may be manufactured of polypropylene (PP), polyethylene (PE) or vinyl polychloride (PVC-U) on individual requests. Intended for construction of gravitational sewerage systems (sanitary, stormwater, combined sewage, industrial) and installation systems (water meters, fixtures, pump stations).

Variants on special manhole solutions

- sewerage flow-through and angular flow-through manhole/inspection chambers
- collecting sewerage wells;
- catch basins;
- discharge manholes, reducing sewer energy;
- chambers for installation systems (water meters, fixtures, etc.);
- underground reservoirs;

Ranges of manhole/chamber riser diameters:

- of double-layer corrugated pipes from DN/ID300 to DN/ID 1000
- of single-layer corrugated pipes DN/ID425, DN/ID600
- of single-layer, plain-wall pipes DN/OD400

Ranges of diameters of connection sockets:

- plain-wall pipes from DN/OD110 DN/OD500
- K2 sewer pipes from DN/OD160 DN/OD1000

Flow-through manhole **DIAMIR 400**

- different options available: flow-through, angular flow-through, collecting;
- channel diameter up to DN 1000;
- flare or flareless stub pipes;

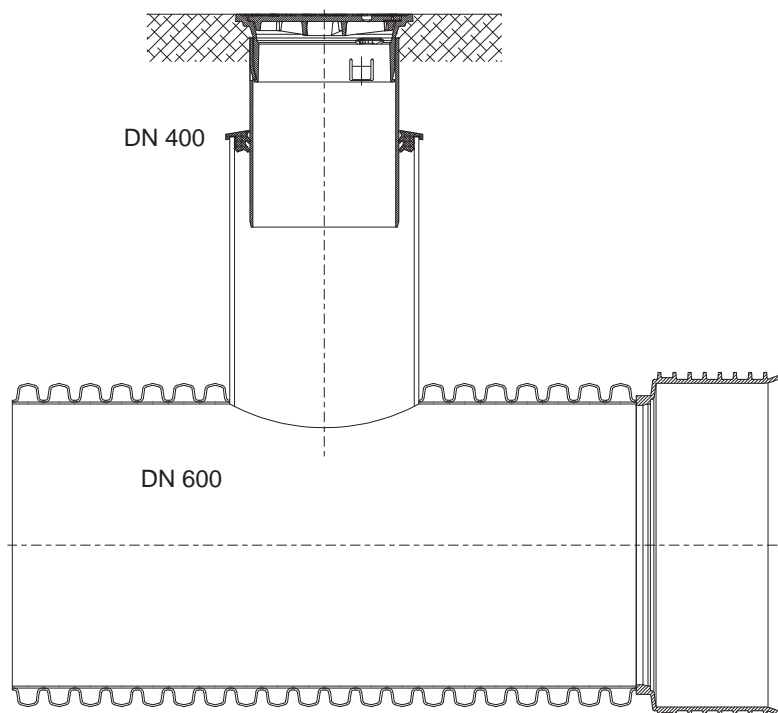

Catch basin with a sump **500**

- riser diameter up to DN 1000;
- outlet diameter DN 110 - DN 200 (in-situ gasket);
- flare or flareless stub pipes;

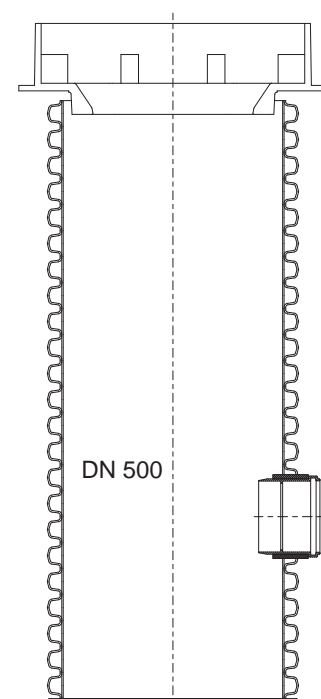

Flow-through manhole **DIAMIR 600**

-different options available: flow-through, angular flow-through, collecting

-channel diameter up to DN1000;

-flare or flareless stub pipes;

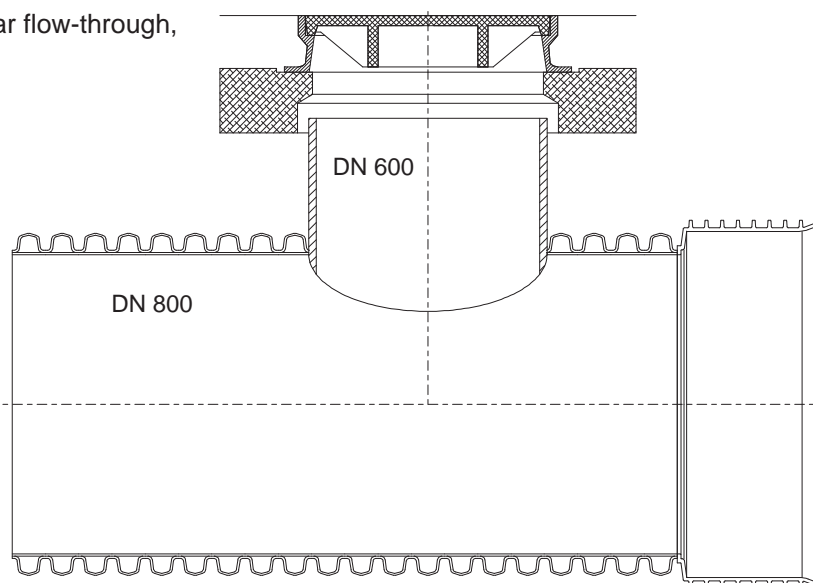

Discharge manhole **DIAMIR 1000**

-different options available: flow-through, angular flow-through

-flareless or flange inlet stub pipe

-flare or flareless outlet stub pipes;

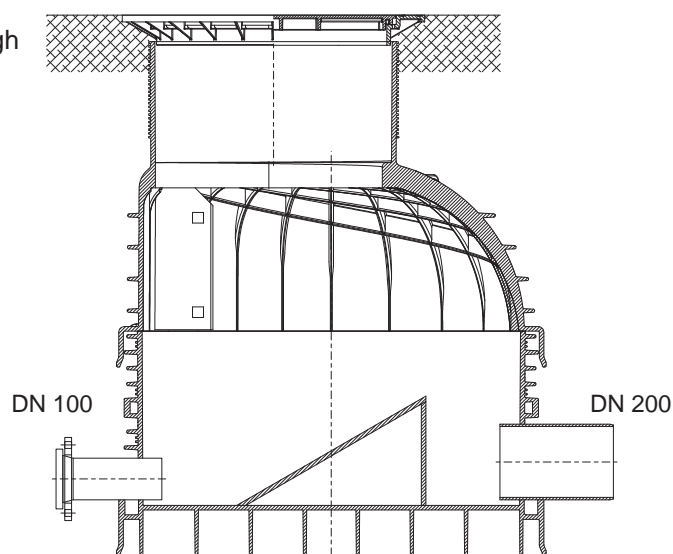

Horizontal tank

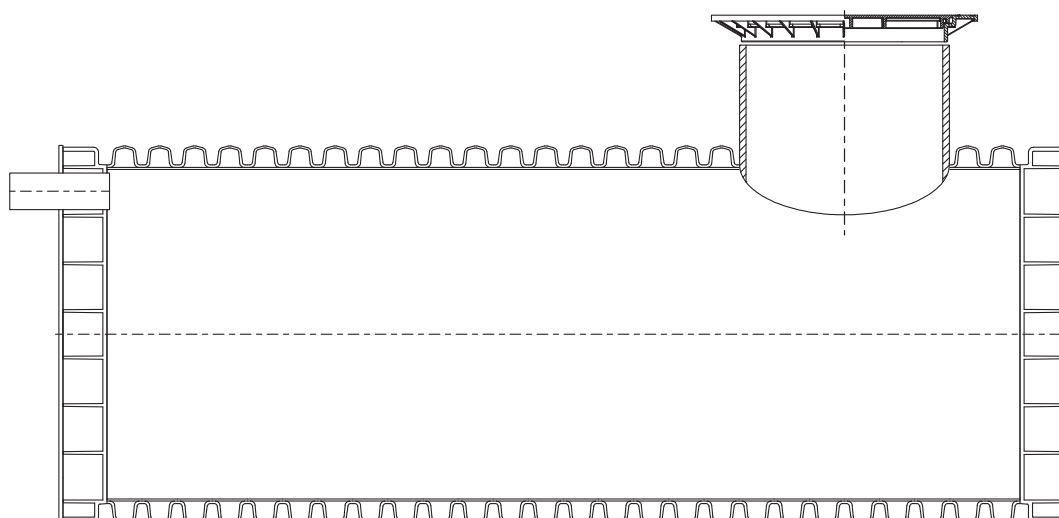

DIAMIR manhole
Construction example

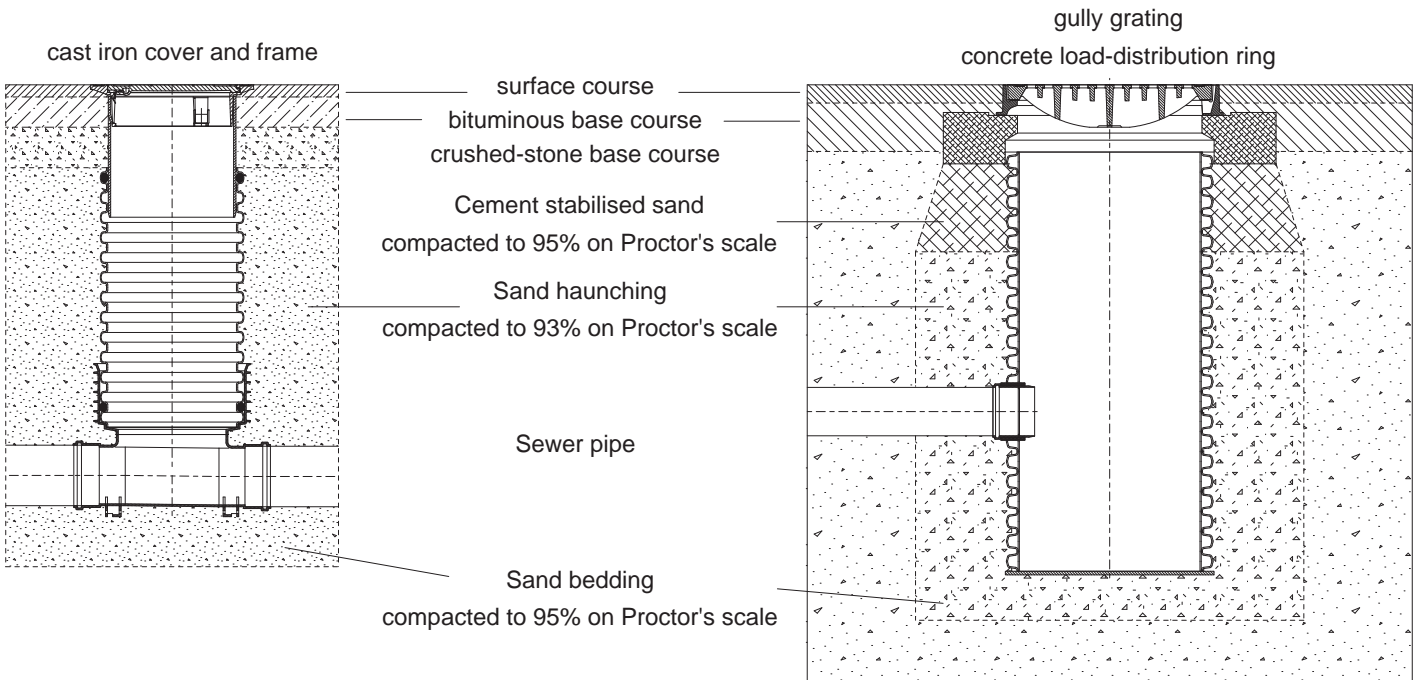

DIAMIR 1000 manhole
Construction example

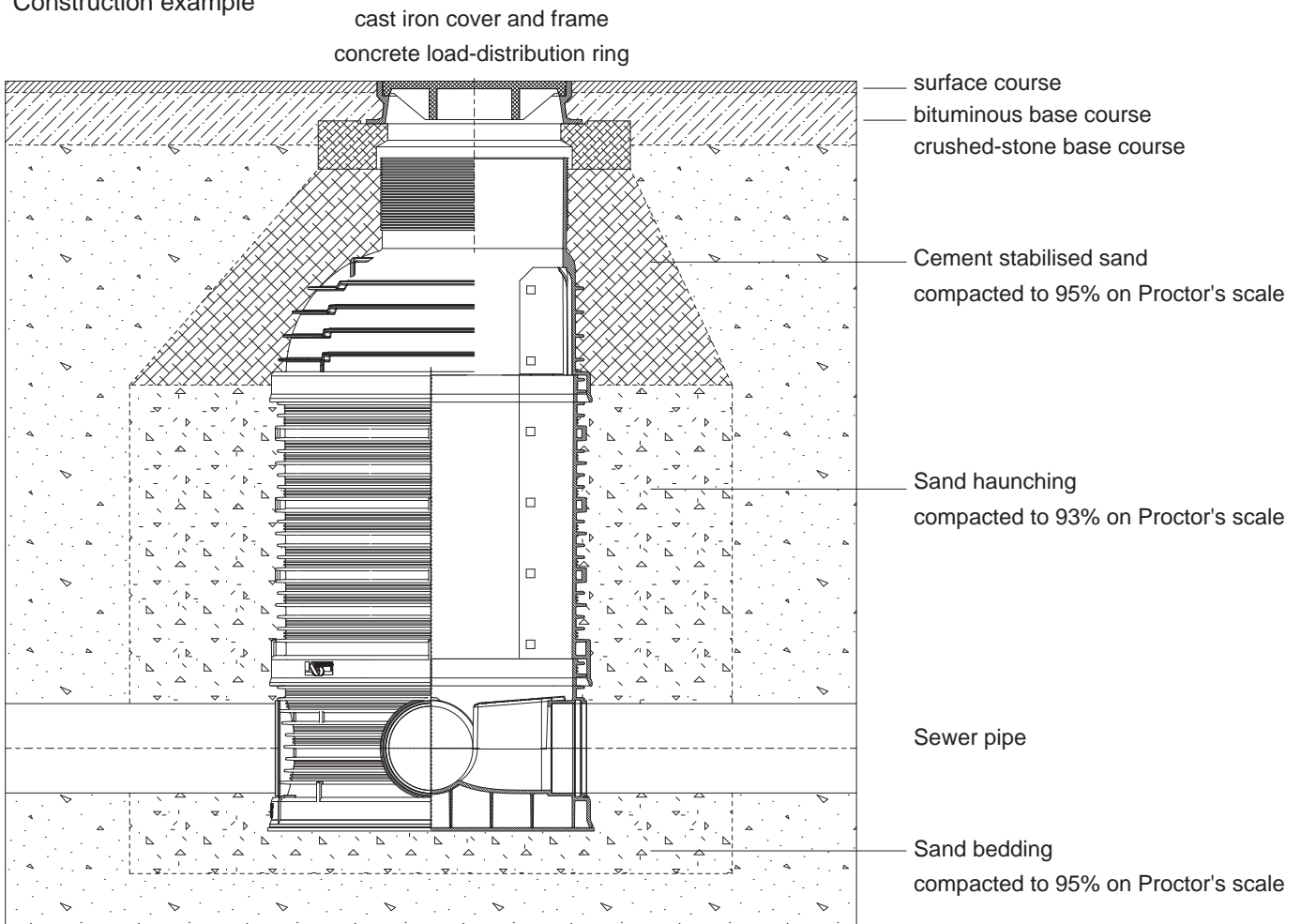

Order form/Query

Contact details:

Company / contractor:

Building site:

tel.:

fax:

mobile:

delivery date:

Flow-through base unit 1000

with additional inlets

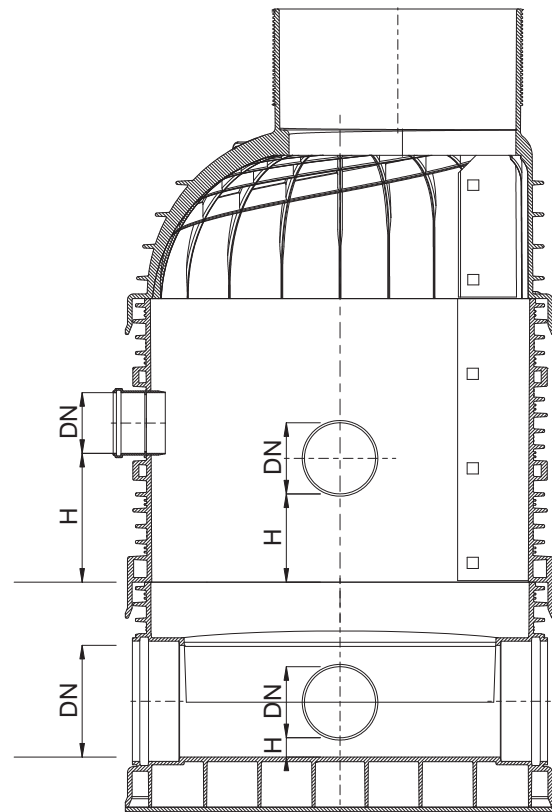
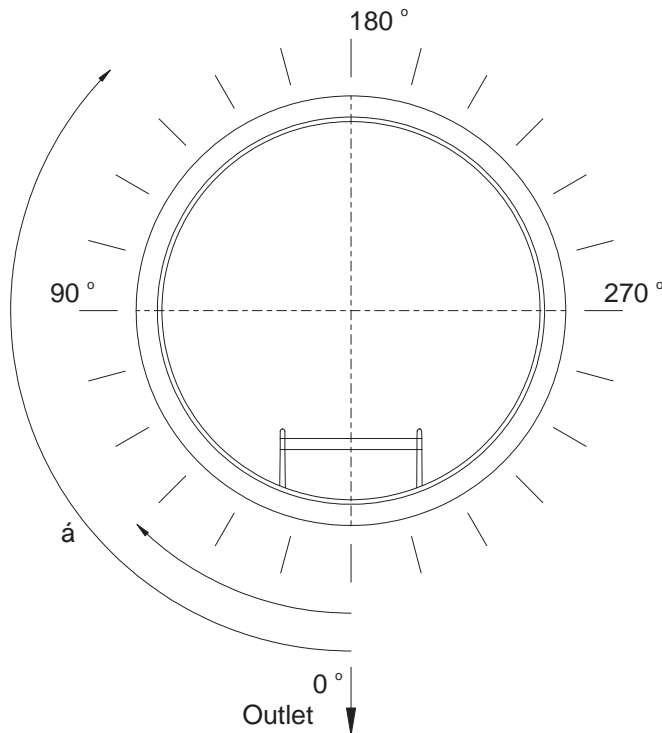

- | | | | | | |
|--------------------------|---|--------------------------|------|--------------------------|-------|
| <input type="checkbox"/> | Flow-through base unit DIAMIR 1000 with additional inlets | <input type="checkbox"/> | H500 | <input type="checkbox"/> | H1000 |
| <input type="checkbox"/> | Blind base unit DIAMIR 1000 with additional inlets | <input type="checkbox"/> | H500 | <input type="checkbox"/> | H750 |
| <input type="checkbox"/> | Ring DIAMIR 1000 with additional inlets | <input type="checkbox"/> | | <input type="checkbox"/> | H1000 |

No.	DN	á	H	Inlet/Outlet slope (standard 0%)
-	[mm]	[mm]	[mm]	%
Outlet		0°		
Inlet 1				
Inlet 2				
Inlet 3				
Inlet 4				

Notes:

- Distances are measured from the blind base unit invert or from the lowest point of a ring
- available diameters of sewerage plain-wall stump pipes 110; 160; 200; 250; 315; 400; 500
- available diameters of K2-Kan sewerage plain-wall stump pipes 160; 200; 250; 300; 400; 500



RELIABLE POLISH SYSTEMS



Przedsiębiorstwo
Barbara Kaczmarek Sp. J.
Małewo 2; 63-800 Gostyń
tel. (+48 65) 57 23 555
fax (+48 65) 57 23 530
www.kaczmarek2.pl