

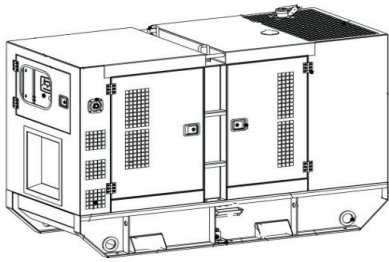

FE POWER JENERATÖR

Demir Makine ithalat ve ihracat san. ticaret ltd. Şti.

**INDUSTRIAL TYPE
DIESEL GENERATOR
USER MANUAL**



ISO 9001 ISO 14001 ISO 10002 ISO 14001 ISO 45000

www.fepower.com.tr

Contents

1. Introduction for generator set

1.1 Security and Warning	4
1.2 Overview for diesel generator	10
1.3 Generator set breakdown drawing	11
1.4 Naming for generator set model	13
1.5 Nameplate	13
1.6 Product quality certificate	14
1.7 Diesel engine	14
1.8 Generator	14
1.9 Control screen	15
1.10 Circuit breaker	16
1.11 Others	17

2 Installation

2.1 General	17
2.2 Storage	17
2.3 Transportation	18
2.4 Generator room installation	19
2.5 Cooling system	23
2.6 Lubricating system	25
2.7 Fuel system	26
2.8 Control system	27
2.9 Storage battery	32



2.10 Power distribution system	33
2.11 generator set Preheater	34
3 Operation	
3.1 Check before operating	34
3.2 Operating	36
3.3 After operating	38
3.4 Examples for generator set configuration picture	39
3.5 Operating record	39
3.6 Precautions	40
4.Maintenance	
4.1 General	41
4.2 Engine	41
4.3 Generator	41
4.4 Control screen	42
4.5 Start battery	42
4.6 Maintenance record	42
5. Warranty ordinances	43
6. Troubleshooting	
6.1 General	45
6.2 List of faults	45
7.Controller Handling Procedures	55

1. Overview





1.1 Safety and warning



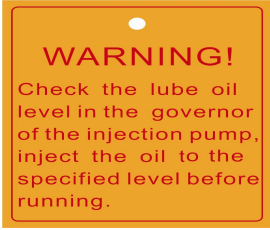
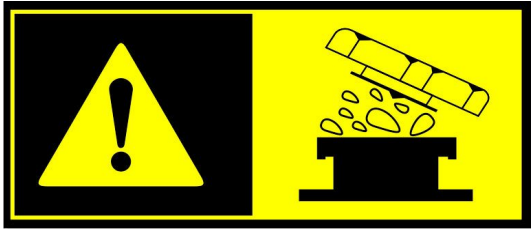

In order to avoid some unnecessary accident and provide security to customers, please don't operate the unit before reading and understanding the instruction and warning in the manual.

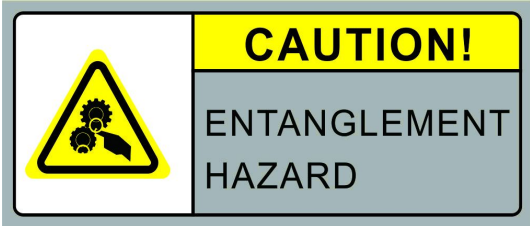

1.1.1 In order to avoid accident and make sure your personal safety, please take some time to study and understand the meanings of these warning labels.

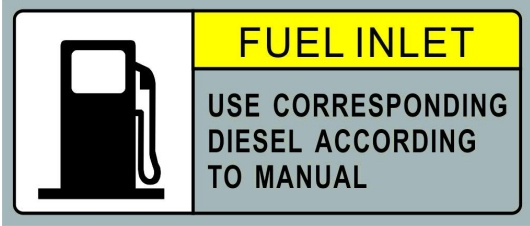
Series Number	Operation Warning Label	Label Note
1	 <p style="text-align: center;">Fig.1-1</p>	<p>Fig.1-1 shows the Warning High Voltage that may result in electric shock</p>
2	 <p style="text-align: center;">Fig.1-2</p>	<p>Fig.1-2 shows the Safety Caution</p>
3	<div style="display: flex; justify-content: space-around; align-items: center;"> <div data-bbox="268 1464 639 1686" style="border: 2px solid black; padding: 5px; text-align: center;"> <p>WARNING!</p> <p>Open water drain valve and release coolant to avoid frost crack after stop and cooled when ambient temperature below 5°C</p> </div> <div data-bbox="684 1464 954 1686" style="border: 2px solid orange; padding: 5px; text-align: center;"> <p>WARNING!</p> <p>Open water drain valve and release coolant to avoid frost crack after stop and cooled when ambient temperature below 5°C.</p> </div> </div> <div style="display: flex; justify-content: space-around; margin-top: 10px;"> <p style="text-align: center;">Fig.1-3</p> <p style="text-align: center;">Fig.1-4</p> </div>	<p>Fig.1-3 and Fig.1-4 show the labels that remind you of opening the drain valve and releasing the coolant to prevent the unit from being frozen due to low ambient temperature (<5°C) during the shutdown.</p>

<p>4</p>	 <p>Fig.1-5</p>	<p>Fig.1-5 show the labels that remind you of Checking lube oil level in the governor of the injection pump,inject the oil to the specified level before running</p>
<p>5</p>	 <p>Fig.1-6</p>	<p>Fig.1-6 shows the label that reminds you of the high temperature. This label sticks nearby the air outlet of the surface muffler. As high temperature will occur at the air outlet when the unit is running, it warns you of the high temperature that may result in injury</p>
<p>6</p>	 <p>Fig.1-7</p>	<p>Fig.1-7 shows the label that reminds you of filling water before starting the unit. It is forbidden to run the unit if there is no sufficient water in the radiator. Note that the water added should be water or antirust water.</p>
<p>7</p>	 <p>Fig.1-8</p>	<p>Fig.1-8 shows the Radiator inlet</p>

<p>8</p>	 <p>Fig.1-9</p>	<p>Fig.1-9 shows the Emergency Stop Switch</p>
<p>9</p>	 <p>Fig.1-10</p>	<p>Fig.1-10 shows the Emergency Stop Switch Function</p>
<p>10</p>	 <p>Fig.1-11</p>	<p>Fig.1-11 shows the Caution Crushing hazard</p>
<p>11</p>	 <p>Fig.1-12</p>	<p>Fig.1-12 shows the Caution Heat Hazard</p>
<p>12</p>	 <p>Fig.1-13</p>	<p>Fig.1-13 shows the Caution Entanglement Hazard</p>

<p>13</p>	 <p style="text-align: center;">Fig.1-14</p>	<p>Fig.1-14 shows the Diesel Inlet</p>
<p>14</p>	 <p style="text-align: center;">Fig.1-15</p>	<p>In Fig.1-15: the left label reminds you of referring to the manual during the repair; the top label of right side reminds you of no open flames; the bottom label of right label reminds you of wearing the ear protection during the operation.</p>
<p>15</p>	 <p style="text-align: center;">Fig.1-16</p>	<p>In Fig.1-16: the left label sticks by the door hole of the unit, reminding you of operating it according to the requirements set in the manual to avoid injury your hand; the right label indicates the high voltage danger, reminding you of operating according to the manual.</p>
<p>16</p>	 <p style="text-align: center;">Fig.1-17</p>	<p>In Fig.1-17: the left label sticks by the door hole of the unit, reminding you of operating it according to the requirements set in the manual to avoid injury your hand; the right label indicates the high voltage danger, reminding you of operating according to the manual.</p>

<p>17</p>	 <p style="text-align: center;">Fig.1-18</p>	<p>Fig.1-18 shows a set of labels which respectively indicate the corresponding position of the oil drain, fuel drain, water drain and Cable Termination hole for your easy operation.</p>
<p>18</p>	 <p style="text-align: center;">Fig.1-19</p>	<p>Fig.1-19 shows the Lifting Point</p>

1.1.2 Warnings labels and contents



1. Read and understand the unit's manual, the generator's manual and the diesel motor's operating instructions before using and maintaining the unit and following all safety warnings so that to reduce the risk, personal injury and equipment damage;
2. All electrical engineering including the grounding must be performed by trained technician
3. **DANGER** The fuel and gases of the generator unit are inflammable and explosive. Proper fuel storage device and reasonable handover procedures shall be employed. ABC grade fire extinguisher should be put around the unit. Do not place other inflammable materials around the unit;
4. **DANGER** It is not allowed to smoke around the unit. Flame or other inflammable objects. Meanwhile, it is forbidden to add fuel to the unit when it is running, because the gases from the fuel and the hydrogen released when the battery is charged are explosive;
5. Keep all doors be locked when unit is running;
6. Read and follow all electrical prewarning and prevention measures described in the manual before starting the unit;
7. **ATTENTION** Before starting the unit, please Check whether the fuel, coolant and lubricant are added and the battery is fully charged;
8. All repairs must be performed by the qualified technician or licensed electrician.

Please do not remove this warning label !

1.1.3 : Besides these warning labels or words, you should also pay attention to these following precautions:

- All safety labels and some precautions on the site should be visible during the installation;
- “Out of service” or similar warning plate should be attached on the start switch or control lever before maintaining or repairing the unit;
- During the maintenance or repair, unauthorized personnel should not get access to the unit; the control system

position; and the emergency stop button should be pressed down;

- Do not start the unit when the fan's protective cover or other safety cover is removed. Never try to repair by putting your hands below or nearby these protective devices when the unit is running;
- Keep your hand, arm, long hair, jewelry and loose clothes away from the belt wheel, belt and other rotating parts. Wear the protection clothing when working in the generator room;
- Do not try to open the radiator's cover before the cooling liquid cools down fully to prevent being injured by the steam (hot water);
- Do not swallow or contact the fuel, cooling liquid, lubricant and electrolyte etc. Once being sprayed by the electrolyte when handling the electrolyte, wash the skin with large quantities of fresh water immediately;
- Wear the ear protection when staying in a high noise environment or running the motor in a confined place for a long time to prevent damage to your ear;
- The electrical output cable must be connected according to the relevant standards, specifications. Use the conforming electrical cable for distribution output;
- When welding is required during the installation of the unit, it is forbidden to make ground connection via the unit (body) to prevent damage by the high current to the internal electrical devices, bearing and bearing bush etc.;
- Make sure that the unit is grounded safely and reliably.

1.2 Overview for diesel generator

- As the primary or standby (emergency) power supply, the unit can be widely used in many crucial sites including telecommunication, hospital, troop, high-rise building, moving train, road construction, industrial and mining enterprise, oil exploration and emergency rescue etc.
- Different configurations are available depending on your specific requirements, such as common unit, stationary unit, movable unit, self-start unit, "three remote" intelligent control unit, combined unit and relevant ATS control screen, combined control system etc.

1.3 Generator set breakdown drawing

Display of Inside Enclosure Main Components

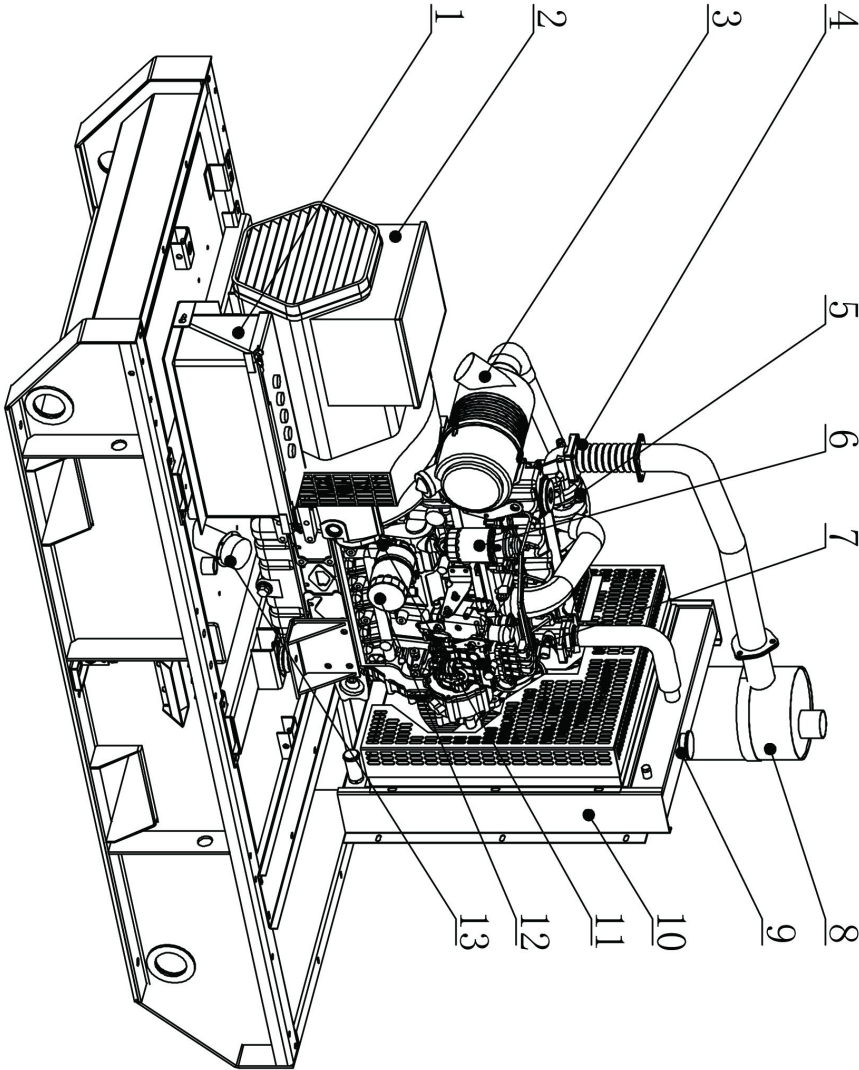

- 1 Battery
- 2 Alternator
- 3 Air Filter
- 4 Exhaust bellows
- 5 Turbo Charger
- 6 Fuel Filter
- 7 Fuel Injection pump
- 8 Muffler
- 9 Radiator cap/fill
- 10 Radiator
- 11 Oil Dipstick
- 12 Oil Filter
- 13 Fuel cap/fill

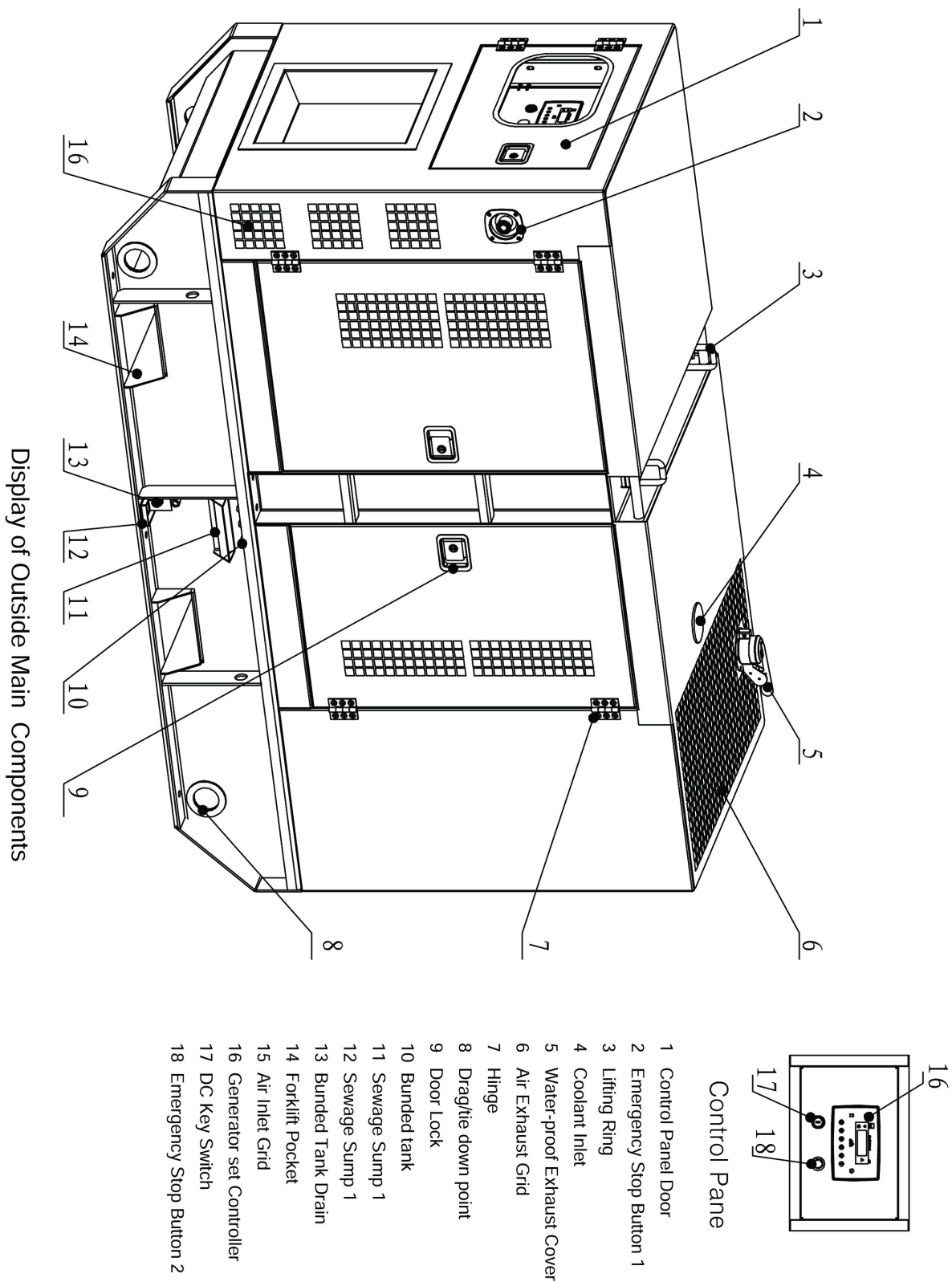

1.4 Naming for generator set model (as shown in Fig.1-23)

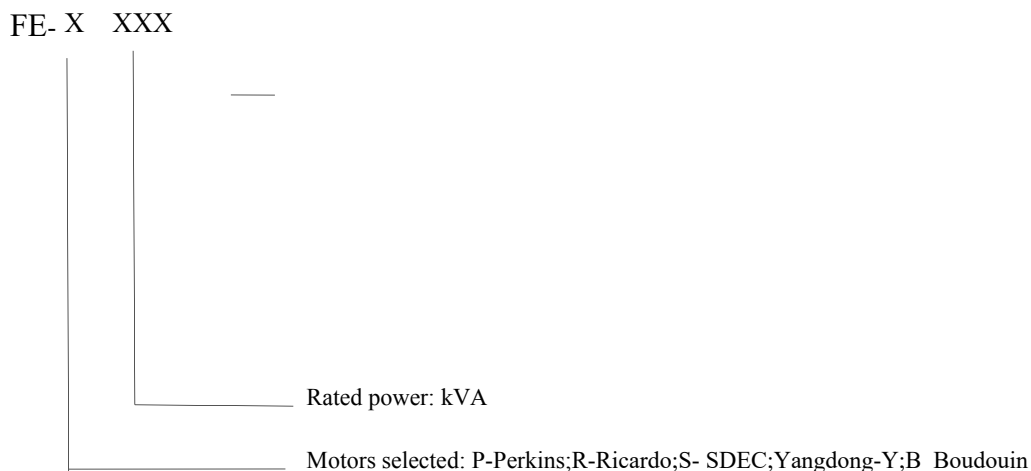

Fig.1-23

1.5 Nameplate

FE POWER diesel generator set is designed with one nameplate, on which the information like unit model, unit number, unit parameters and production date is provided. Fig.1-24 shows the nameplate of the unit. The unit number is unique. You must record the unit number and model correctly. Once you want to buy parts or need repair service, you should provide us with the above unit model and number accurately, so we can offer high quality after-sale service

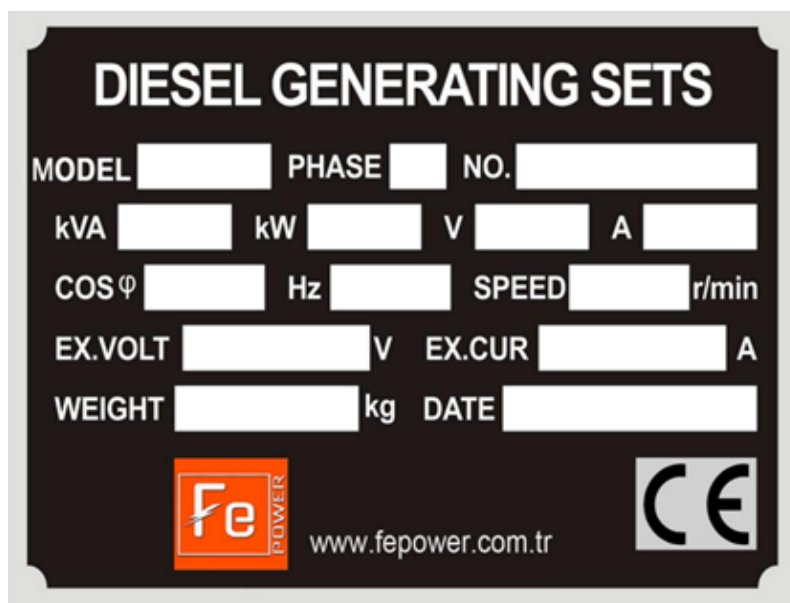
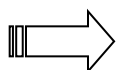

Fig.1-24

1.6 Product quality certificate

One certificate of compliance is provided in the documentation package for diesel generator unit, indicating that this unit has passed the factory testing and inspection and therefore can be delivered to users for operation. Fig.1-25 shows the certificate of compliance of FEPOWER generator unit:

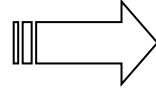

Fig.1-25

1.7 Diesel Engine

- According to different power levels, and considering the performance and advantage of different brands in the specific power scope, the unit selects different diesel motors. The typical brands include Cummins, Deutz, Volvo, Perkins ,etc.
- The unit not only requires that the selected motor has excellent performance and high reliability but also pays special attention to its technological advance in the aspects of waste gas emission reduction, fuel consumption reduction and noise control. The diesel motor has complete auxiliary facilities, including fan, water tank radiator, air cleaner, engine oil cleaner, diesel cleaner, oil-water separator (available some models) and charge generator etc. The automatic speed regulation system (mechanical or electronic type, intelligent electronic injection control system) can control the rotation speed of the diesel motor precisely and make sure the unit keeps stable output frequency. Additionally, except for tiny minority of units with low power, other models and types are equipped with the turbocharging system to reduce the weight of the unit and improve the horse power output.
- For the brand, model and specifications of the specific diesel motor, refer to the documentation package: Motor's Operating Instructions.

1.8 Generator

- The unit uses the world-class alternator. Or other world famous brand alternators. ➤
The alternator has the following features:

- Four-pole brushless self-excited, IP22 protection grade (Marine IP23 protection grade). H grade insulated steel housing structure makes sure the generator can run in the tough environment.
- The stator winding is of 2/3 short pitch, which can effectively inhibit the waveform distortion of the output voltage and reduce the magnetic field heating-up.
- The dynamic balancing test should be conducted prior to the rotor assembly, and the integral damping winding is set on the rotor to restrain the voltage oscillation under non-constant load, to ensure the superior steady state of generator.
- The output power of exciter rotor is output to the host rotor through the three-phase full-wave bridge rectifier, which is protected by a surge suppressor against the damage from the impact by short circuit or phase step in parallel arrangement.
- Automatic voltage regulator (AVR) can automatically reduce load to protect the generator. It allows one-time full-load exertion on the generator, and the steady voltage regulation can achieve $\pm 1\%$ (can meet $\pm 0.5\%$ at special request). If permanent magnet generator excitation (PMG) system is chosen, the generator will have higher capacity to start and have interference resistance for the output voltage waveform distortion of host stator generated by the nonlinear load (such as SCR DC motor, UPS, etc.).
- Telephone Influence Factor (TIF) < 50 , Telephone Harmonic Factor (THF) $< 2\%$, brushless device and high quality AVR make sure small interference to the radio transmission.

1.9 Control screen

1.9.1 Control screens placed ways:

- 1) Soundproof generator set is usually placed on the broadside of the generator set
- 2) The open type the generator set has two kind of distribution box, one is on the broadside of the generator set, the other one is at the end of the alternator.
- 3) Distribution box of rain-proof type generator set is above the alternator open type with large power, the generator set's control screen and circuit breaker are separate. The control screen installed on the broadside of the generator set, the circuit breaker installed in the separate box.
- 4) Parallel box usually adopt the separate box.

1.9.2 Our company selects the well-known trademark controller such as DEEP SEA, Smartgen, Comap, ect. It can be collocated in many ways according to customers' requirement.

The functions of the generator set: system

- Start, stop

- automatic ,shutdown
 - Main parameters detection of alternator: phase voltage and line voltage, current, frequency, power, etc;
 - Detection of engine operating parameters: Oil pressure, water temperature, rotation speed, etc.
 - All types of control screens have the fault protection function (automatic shutdown), including low oil pressure, high cooling liquid temperature, over-speed and emergency stop (button or key switch) etc.
 - According to customer's requirement, it can realize "Three remote" function, and carry out positioning and monitoring by the Internet or short massage.
- These are directly displayed on the screen, as shown in Fig.1-26, Fig.1-27 and Fig.1-28.



Fig.1-26(DSE6020)



Fig.1-27(DSE7320)



Fig.1-28 (DSE8610)

1.10 Circuit breaker (Standard configuration)

- As shown in Fig.1-29, in order to protect the main alternating-current generator from being damaged by the overload current and other abnormal impact, one electrical circuit breaker matching with this unit is installed on the electrical output terminal. Generally, it is installed inside the generating control box nearby the generator. For the high power unit or combined unit, this breaker is installed in the outgoing screen or combined screen.

- When making the distribution output, draw out the cable from the bottom of the Circuit breaker directly. The cable is drawn out from the outgoing sleeve of the housing, as shown in Fig.1-30 (put the cable through the housing's wiring hole and connect it to 1,2,3 phases and N phase at the Circuit breakers load terminal).



Fig.1-29



Fig.1-30

1.11 Others

- Besides the above components, the unit is also equipped with other key accessories, such as start battery, battery cable, muffler (open-frame unit), motor accessory box etc. For the specific accessories of different models, refer to the packing list.

2. Installation

2.1 General

- After you select the model, the volume, weight, power and use type of this unit are known. According to your actual use requirements and the specific conditions of control system and distribution system, you can establish the installation and implementation plan for the diesel generator unit.

2.2 Storage

- For calculating the warranty term scientifically and meeting your desire of putting the unit into operation as soon as possible, it is suggested to install and test the unit once it arrives at the working site and assign a special personnel to be responsible for the operation and daily maintenance.
- If the unit needs to be stored for some time due to some special reasons, reasonable and feasible storage plan should be made according to the storage time. Long-time storage will impose decisive adverse effect on the diesel motor and main alternating-current generator. It is essential to select correct storage method.
- The unit should be stored by steps, including cleaning the unit fully, keeping the unit dry and ventilated, replacing the new lubricating oil with proper quality, thoroughly draining the cooling liquid in the water tank and conducting antirust treatment on the unit etc.

- During the storage, make sure that the unit is not bumped by the tree and other goods to avoid any damage. Besides, it is suggested to build a special independent warehouse. It is forbidden to place the inflammable and explosive goods around the unit. Some firefighting measures must be taken, e.g. setting ABC fire extinguisher etc.
- In order to prevent the damp going into the main alternating-current generator coil and minimize the damp condensation that may reduce the generator's insulation performance, even affect the unit's serviceability, note to maintain the area around the generator dry or take some special measures (such as proper heating and dehumidifying device) to keep the coil always in the dry conditions.
- The unit storage should avoid overheating, undercooling or exposure to the rain or sun etc. The start battery used in this unit is a plumbic acid high energy battery. Before testing and using the unit, it is suggested not to add electrolyte. If it has been added, note to charge it every 5-8 weeks to avoid damaging the battery or reducing its service life. During the storage, avoid direct exposure to the sun or rain.
- After the unit is stored for some time, before the installation and use, note to check whether the unit is damage; whether the electrical devices are oxidized; whether all connecting parts become loose; whether the main generator's coil still keeps dry; and whether the body surface is clean and dry. Take proper measures when necessary.
- Similarly, the above contents are applicable to the installation of the unit in the generator room, namely the basic requirements on the generator room.

2.3 Transportation

- During the transport, the unit should be provided with necessary safety protection. Additionally, the unit should be fixed in the compartment firmly to avoid vibration that may cause its parts to loose or even be damaged. In the transport process, there should be no person or goods on the unit to avoid damage to the unit.
- When unloading the unit from the vehicle, use the forklift or hoisting equipment to avoid the unit tipping or falling on the ground, leading to damage.
- The unit is sold along with hoisting channel steel, by which you can hoist the unit. Never hoist the unit by the sling rings of the diesel motor or alternating-current generator.
- For the non-standard units that have special purpose and are used in the special case (such as movable power station or mute or noise type unit), movement, transport and hoisting will become much easier. As such units have specially designed housing for easy transport and installation. What's more, some types are specially installed with rubber wheels. Such housing also provides many parts on the unit with good safety protection, further avoiding the damage from rain, sun and collision during the transport. It can also prevent mis-operation

by unrelated personnel.

2.4 Generator room installation

- In the installation plan, the first step is to select the site for installing the unit (the storage requirements in 2.2 are also the basic requirements for selecting the generator room). Generally, the site is selected mainly on the basis of use convenience and economy of distribution connection as well as helpfulness to the use and maintenance. However, it is also important to consider the following aspects when selecting the installation position.
 - Measure the levelness of the foundation with a level gauge during the installation to make sure the unit is fixed on a horizontal foundation;
 - Make sure that the generator room is ventilated so that the hot air exhausted from the radiator can be guided to flow out of the generator room and will not return;
 - Make sure to minimize pollution to the ambient environment by the noise and smoke generated in the running process;
 - There should be sufficient space around the unit for cooling, operation and maintenance. Generally, it is not allowed to place any other goods within the scope around (1~1.5m) and on (1.5~2 m) the unit;
 - Make sure that good lighting equipments are available when working at night. Protective cover should be provided for outdoor application to avoid damage to the unit by rain, sun, wind, overheating and freezing;
 - The exhaust pipe of the diesel motor should be unblocked. The pipeline should not be too long or turn a corner suddenly. When the exhaust pipe is connected to outdoor, incline the outside part downwards slightly so that the condensated water in the pipe can flow out;
 - It is forbidden to place inflammable or explosive goods around the unit. The environment should be kept clean without any goods that may generate corrosive gases (acidic or alkaline).

2.4.1 Foundation

- The foundation base for holding and fixing the unit is very important. It must meet the following requirements:
 - Support the weight of the entire unit and the dynamic impact load generated by the unbalanced force in the running process;
 - Have sufficient rigidity and stability to avoid any deformation that may affect the axiality of the diesel motor and main alternating-current generator and their accessories;
 - Absorb the vibration generated in the running process to minimize the vibration transmission to the foundation and wall;
 - Keep the foundation smooth as possible as it can;
 - Reserve a dump tank (when possible) for the waste water and oil to flow away duly. Reserve a cable trench for

the generator distribution output.

- Generally, the concrete foundation is a reliable and simple installation method, therefore high priority should be given to this method. When casting the concrete base, make sure that concrete surface is smooth without any damage. It is suggested to install the unit and its exhaust system with the level gauge or similar meters.

Generally, the scale of the concrete platform only needs to keep within the range of 100~200mm. The subsoil for building the concrete platform must also have sufficient carrying strength to carry the entire unit and the concrete foundation.

- For the layout of the unit, refer to Fig.2-1.

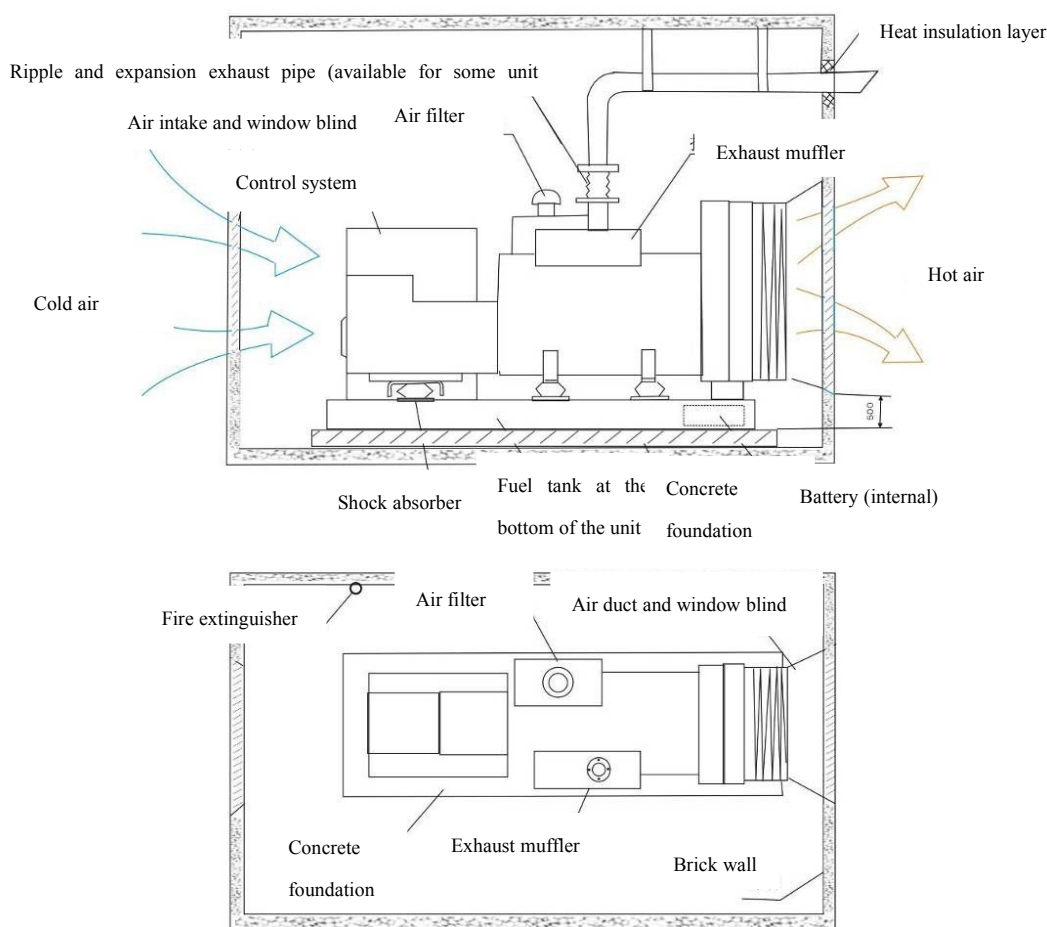

Fig.2-1

2.4.2 Ventilation

- When a unit with integrated radiator is installed in the generator room, the basic principle is to exhaust the hot air out of the generator room and suck the low temperature air into the generator room, as well as try to reduce hot air inflow.
- Fig.2-2 Shows the ideal position relationship between the unit and the wall in generator room. Its purpose is to suck the cold air from the lowest place, force it to go through the radiator element, and then exhaust it out of the

generator room.

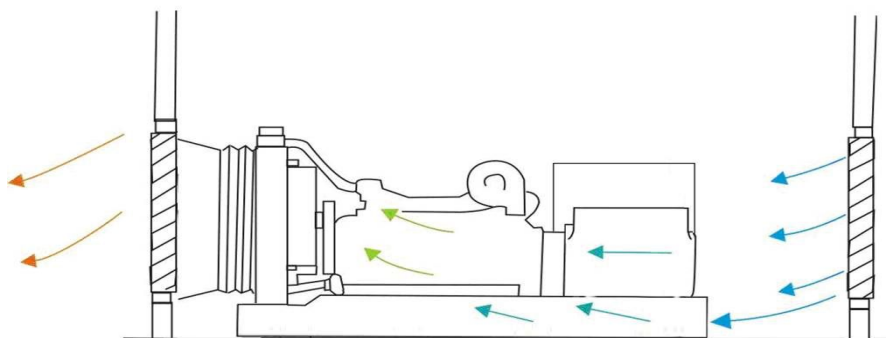

Fig.2-2

- You can fabricate a wind scoop with the metal or plastic plate. The wind scoop must be connected with the radiator in a flexible manner so as to isolate the vibration transmission and make sure the hot air is exhausted thoroughly.
- The effective circulating section area in the wind scoop should be more than 1.25 times of the front area of the radiator element. The wind scoop should be smooth without sharp angle to reduce the air resistance. The effective circulating area of the air inlet should also be more than 1.25 times of the front area of the radiator element.
- When you install the protective screen or shutter at the air inlet and air outlet or there are many large cambers, its effective circulating section area will decrease and the resistance will increase. Therefore, it is necessary to further increase the circulation area.
- Generally, the air blown by the fan is sufficient to meet the ventilation requirements of the generator room. The temperature of the incoming air should be lower than 40 °C. If it keeps higher than this value, the output power will decrease. Therefore, you must suck the fresh air from outside of the generator room duly to supply air to the motor.
- If the motor is equipped with one remote radiator, you must consider conducting forcible ventilation to the generator room.
- For the motor equipped with the thrust fan, it is preferred to use one independent pipe to exhaust the waste gases from the crankcase out of the generator room, otherwise they will deposit on the radiator and get the radiator clogged, leading to reduction of the radiation capability.

2.4.3 Smoke evacuation

- The standard unit is equipped with industrial muffler (having the same specifications with the unit), flexible corrugated pipe and elbow. You can design and install the smoke evacuation system by using these three main

accessories. When doing this, you should also consider the following aspects:

- Make sure that the entire exhaust back pressure should not exceed the specified maximum allowable value; (generally, the maximum exhaust back pressure does not exceed 5 Kpa)
 - Fix the smoke evacuation system so that the smoke evacuation manifold and turbine booster are not affected by the longitudinal pressure and lateral stress;
 - Reserve space for the (pipeline) thermal expansion and contraction;
 - Reserve space for the unit vibration;
 - Reduce smoke evacuation noise.
- Fig.2-3 shows the typical smoke evacuation installation.
- Too high exhaust back pressure will directly result in:
- Output power loss;
 - Poor fuel economy;
 - Rising smoke evacuation temperature.

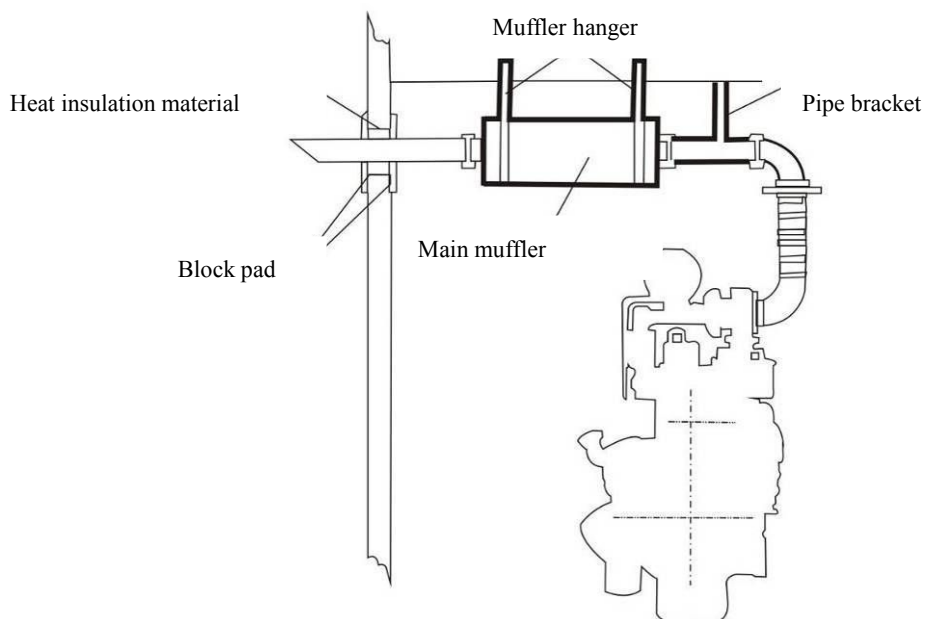

Fig.2-3

- The industrial muffler equipped on the unit is an absorption muffler. Its working principle is to absorb the noise by installing an absorption lining inside the muffler, so it has wide noise reduction frequency range.
- The exhaust back pressure value of the entire system is obtained by adding those of the muffler and smoke evacuation pipeline together.
- If more than one unit is installed, try not to exhaust the waste gases from the same flue. If the conditions don't allow installing independent smoke evacuation pipe, when the total exhaust back pressure is not exceeded, the

smoke evacuation branch pipe should be equipped with a movable separator that can prevent return.

- In the smoke evacuation system, the smoke evacuation pipe should be connected to the diesel motor booster with the flexible corrugated pipe. It has three functions:
 - Separate the vibration and the weight of the smoke evacuation pipeline with the diesel motor;
 - Compensate the thermal expansion of the smoke evacuation pipeline;
 - If the unit is installed on the shockproof under-frame, compensate the swing movement when the unit starts and shuts down.
- In case that the rainwater or condensed water goes into the smoke evacuation system, serious damage may occur. Therefore, the long smoke evacuation pipeline should be designed with one water outlet, whose position should be close to the unit as possible as it can.

2.4.4 Noise reduction

- Generally, the unit will generate 80~100 dB noise in the running process. The noise will go up slightly as the load increases.
- In order to meet the noise reduction standard set by the local environmental protection agency, prevent the noise and waste pollution to the ambient environment, as well as avoid affecting the normal living of the ambient residents, it is extremely important to take measures to reduce the running noise of the unit.
- The noise reduction is a comprehensive professional engineering. When designing and building the noise reduction plan, you should fully consider many factors, such as the lowest air intake/output standard required by the unit's normal running, exhaust back pressure not exceeding the reference value etc. Otherwise, it will seriously affect the power output, leading to high temperature rise on the unit body and frequent unit failure, even shortening the service life of the unit.
- An integrated mute unit is available for your selection.

2.5 Cooling system

- The unit uses the closed circulating fluid cooling method (with fan). Its cooling system's circulating loop basically consists of:
 - Pump;
 - Channel in the motor cylinder body;
 - Thermostat ;
 - By-pass pipe between the thermostat and the pump;
 - Water tank radiator;

- Pipeline and hose;
- Engine oil cooler;
- Cooling liquid filter (available on some models).
- For the non-standard unit (such as split type water tank unit), the water tank radiator should be replaced by the heat exchanger. Meanwhile, supplementary water tank and remote cooling fan should also be provided. If the remote cooling fan is installed in a high position, transitional water tank should be provided to prevent the heat exchanger damage due to too high internal pressure.
- Various dirt attached on the radiator element will greatly reduce the cooling performance of the radiator. Therefore, in the dusty environment, it is very necessary to wash the radiator regularly.

2.5.1 Cooling liquid

- The cooling liquid has the following three functions:
 - Provide sufficient heat transfer capability;
 - Prevent all metal materials in the cooling system corroding;
 - Provide sufficient anti-freezing capability.
- The cooling liquid should be mixture of water and anti-freezing fluid or water and antirust fluid, where the water's PH value should be kept in the range of 6~8. Generally, it is suggested to use the distilled water.
- In the area where freezing occurs, the cooling liquid should contain 40%~ 60% anti-freezing fluids. It is suggested to use the mixture of 50% anti-freezing fluid and 50% purified water. It should be prepared in an independent container, and then added to the water tank. Its anti-freezing capability is about -30°C. (for details, refer to the operating instructions of the anti-freezing fluid that you select)
- Using conforming cooling liquid is the key that makes sure the motor runs normally.
- It is not suggested to add anti-freezing fluid into cooling liquid over 60%, otherwise it will reduce the cooling performance of the unit.
- In the area where freeze does not occur, the antirust fluid can be used to replace the anti-freezing fluid. When the mixing ratio between the antirust fluid and the purified water keeps at 1:30 or so, good antirust effect can be achieved. It will not reduce the cooling performance of the unit. After adding the antirust fluid, run the unit to the thermal engine status to obtain the optimum corrosion protection

⚠ Never mix different types of additives like anti-freezing fluid and antirust fluid, because it will generate large number of bubbles that may reduce its cooling performance.

2.5.2 Change the cooling liquid

- The cooling liquid should be changed every two years to avoid reducing the cooling performance due to deposition in the cooling system. Another reason is to avoid the rust danger, because rust will resist the effective performance of the cooling liquid and the water temperature sensor will fail after a long time.

When replacing the cooling liquid, wash the system with fresh water till the flushed water is very clean.

- When draining the cooling liquid, make sure the unit is shut down and the body cools down fully before opening the filling cover of the water tank, and then opening the drain cover or drain plug. If the unit is equipped with a cooling liquid filter (available on some models), remove and replace this filter.

2.5.3 Add the cooling liquid

- Before adding cooling liquid to the cooling liquid system, make sure its drain cover is tightly closed and the drain plug is in the correct position;
- Add the cooling liquid to the system at a proper speed to avoid forming bubble layer in the system;
- The air must be exhausted via the filling port or exhaust valve. If the cooling system is connected with the heater, its control valve must be opened. In the filling process, note to keep ventilated in the unit;
- When adding the cooling liquid, the level should reach at 5 cm below the welding surface of the filling plug (or cooling liquid level indicating line). Make sure to add the cooling liquid after the unit shuts down and cools down fully. Before the system is ventilated and the cooling liquid is added fully, do not start the unit. After adding the cooling liquid, note to start and preheat the unit. Meanwhile, check the level of cooling liquid. If necessary, refill the cooling liquid. The water tank should be added with the cooling liquid whose specifications are the same with those of the original cooling system;
- For some units equipped with the cooling liquid filter, open the filter valve by placing the handle in the vertical position before being put into operation formally.

2.6 Lubricating system

- The main function of the lubricating oil is to reduce the friction, wear-out and prevent corrosion on all part surfaces by providing enduring protective oil film among the running parts of the motor. High temperature cylinder and bearing have high dependence on the lubricating oil film.
- The lubricating oil also has important cooling effect on many parts of the motor.

⚠ The lubricating oil and filter in the lubricating system must be replaced regularly according to the operating environment and time, which can refer to the engine manual.

2.6.1 Lubricating oil

- Every time when you starting the unit, you must check whether there is any need to add the lubricating oil according to the oil pointer position. In the long-time running process, check (6~8h/time) its level regularly to

make sure the lubricating system works normally.

➤ **Lubricant recommendation:**

➤ **When the ambient temperature is $>-5^{\circ}\text{C}$** , type of oil: 15W-40 CF4、15W-40 CG4、15W-40 CF4/SG 或 15W-40 CG4/SH.

➤ **When the ambient temperature is $<-5^{\circ}\text{C}$** , type of oil :10W-30 CF4、10W-30 CG4、10W-30 CF4/SG 或 10W-30 CG4/SH.

⚠ Good quality and proper viscosity lubricating oil is the key for normally running. Replace the lubricating oil at regular intervals is equally important. The fault caused by using the poor quality lubricating oil mixed with different models or not replacing the lubricating oil for a long time is beyond the warranty scope.

2.7 Fuel System

➤ The unit requires that the fuel added (namely diesel) should be clean and free of air or water, as well as have proper pressure. Its sulphury content must meet the national standard and its use temperature grade should meet the temperature requirements on the site.

➤ For the specific requirements on the fuel, refer to the Motor's Operating Instructions.

➤ The fault caused by using poor quality fuel is beyond the warranty scope.

2.7.1 Oil Tank

➤ Standard oil tank is available as optional part.

➤ When making the oil tank by yourself, you should note that the standby fuel tank is made of stainless steel or steel sheet. Do not paint or galvanize the inside of the fuel tank to prevent any chemical reaction with the diesel, which may generate impurities that damage the unit and reduce the quality, cleanliness and burning efficiency of the diesel.

➤ Additionally, the oil tank should also be equipped with:

- Vent pipe on the top;
- Oil level observation window;
- Waste drain valve at the bottom;
- For some units, the oil level should be higher than injector's position to avoid oil return and difficult start.

2.7.2 Oil Pipe

➤ The oil pipe should be laid in such manner that fuel will not be affected seriously by the unit radiation;

➤ The maximum allowable temperature of the fuel before the injection pump is 60°C ;

➤ It is important to make sure no oil leakage exists on the oil inlet pipe and oil return pipe.

➤ The unit is connected with the oil pipeline with a hose. If the unit is installed in a flexible manner (by a shock

absorber), a hose must be provided.

- The internal diameter of the oil pipe should be above 8 mm. If the fuel pipe's length is more than 6 m, the pipe diameter should increase by above 20%. The oil return pipe should be connected back to the top of the oil tank. Do not directly connect it to the oil inlet pipe.
- For the units with base fuel tank, ready-made oil tank, oil pipe and oil level gauge are available.

2.8 Control System

- The control system is an integral part of the unit and also the heart of the unit. The application of the intelligent control system in the unit is helpful to improving the quality of the electric energy and the automation level of the diesel unit.
- The unit is equipped with intelligent control screen. Different types are available to meet your different needs:
 - Self-start control screen: The unit can realize both local manual control and remote control (by the external signal line). You need to connect the signal control line to this screen correctly (for details, refer to the control screen's documentation package);
 - "Three-remote" communication fully automatic control screen: On the basis of the "self-start control screen" function, it also has the communication mode. For the specific communication and communication protocols, refer to documentation package;
 - "ATS" converter (optional): Fig.2-4 shows one of ATS converters. It is the automatic conversion switch of the generated power/utility power automatic conversion or the primary/secondary double-circuit power supply (for details, refer to the control screen's documentation package);



图 2-4

Fig.2-4

- Combined screen (optional): Two or above fully automatic (manual) combined control screen (for details, refer to the control screen's documentation package).

➤ The common controller panels and their function keys are described as below.

DSE6020 (as shown in Fig.2-5): DSE6020 is a control module, which can automatically start when the mains supply is invalid. It can realize the functions of AMF and ATS, furthermore, it is applicable to injection or not injection engine. Rotating speed, oil pressure, water temperature, oil level and battery voltage can be showed in the screen. Frequency, three-phase voltage, current and the parameter of the generator set are also can be showed. It can preset two operating modes and operating parameter. The operation time of the generator set, historical record and functions of the generator set protection and alarm control are all can be found.

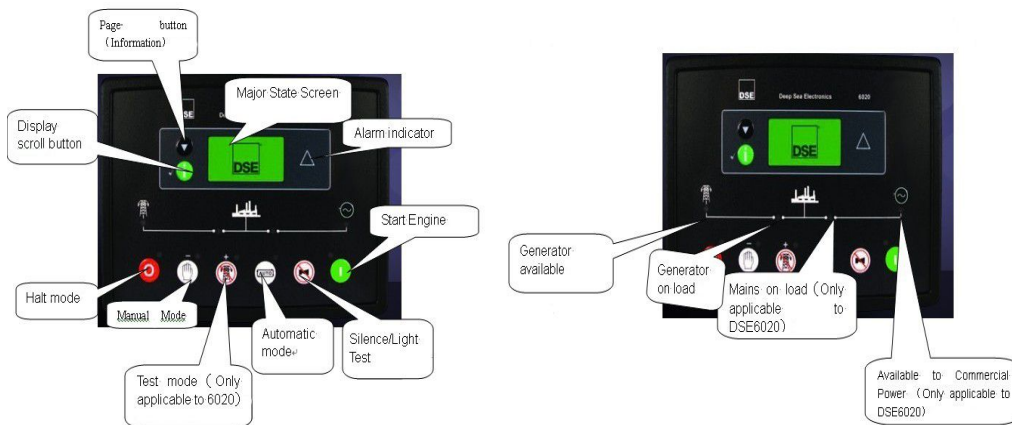

Fig.2-5

● **DSE7320 (as shown in Fig.2-6):** The DSE7310 is an Auto Start Control Module and the DSE7320 is an Auto Mains (Utility) Failure Control Module suitable for a wide variety of single, diesel or gas, gen-set applications.

Monitoring an extensive number of engine parameters, the modules will display warnings, shutdown and engine status information on the back-lit LCD screen, illuminated LEDs, remote PC and via SMS text alerts (with external modem).

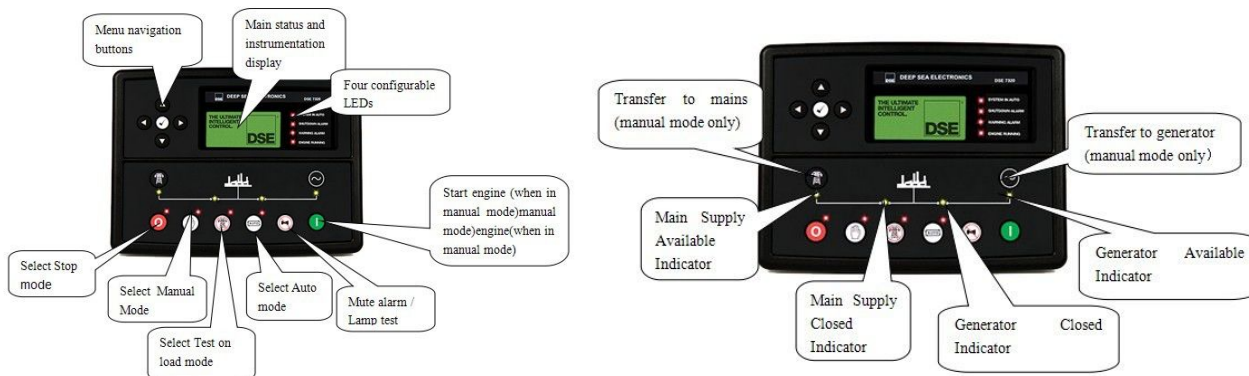

Fig.2-6

DSE8610 (as shown in Fig . 2-7): The DSE8610 is an easy to use multi-generator load share system, designed to synchronise up to 32 generators including electronic and non-electronic engines. The DSE8610 monitors the generator and indicates operational status and fault conditions, automatically starting or stopping the engine on load demand or fault condition. System alarms are annunciated on the LCD screen (multiple language options available), illuminated LED and audible sounder.

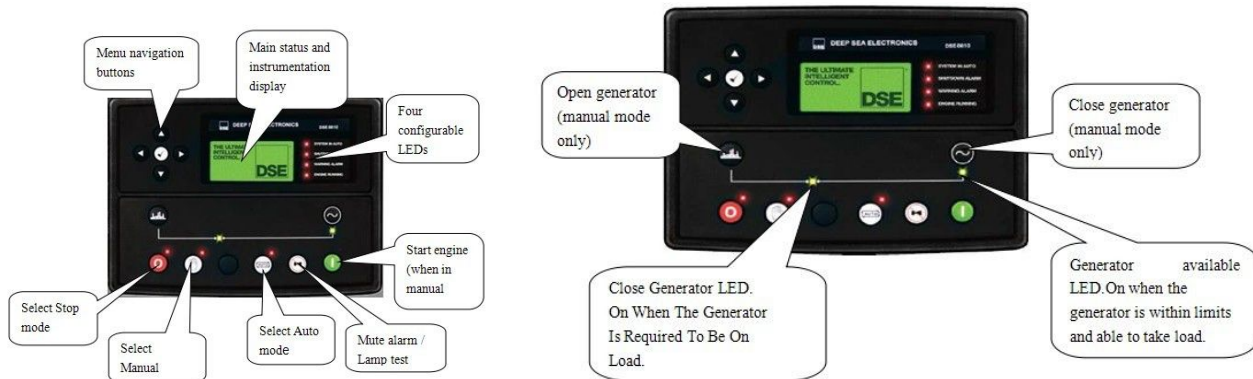

Fig.2-7

DSE890(as shown in Fig.2-8): The Gateway connects to the DSE data server by integral Ethernet connection or GPRS (DSM or 3G mobile internet) and includes GPS (satellite location) functionality. This is most suited To remote and/or mobile locations.



Fig.2-8

Alternator operation

➤ Our C series generator sets adopt the ComAp IL-NT AMF20 control module, the main generator set operation is done on control screen, of which operation panel is shown as following button:

- | | |
|---|--|
| 1 Mode → : forward selecting generator set open operation mode (OFF-MAN-AUT-TEST) | 7 MCB ON/OFF:manually open/close the utility breaker switch(left side) |
| 2 Mode←: backward selecting generator set operation mode (OFF-MAN-AUT-TEST) | 8 GDB ON/OFF: manually open/close generator set breaker switch(right side) |
| 3 HORN RESET:cancel the alarm voice,when pressing this button the trumpet stops | 9 PAGE:cyclically select the display mode(measurement mode/adjustment mode) |

- | | |
|--------------------------------------|---|
| 4 FAULT RESET: fault and alarm reset | 10 ↑: flip up screen or increase set points |
| 5 START: start the generator set | 11 ↓: flip down screen or decrease set points |
| 6 STOP: stop the generator set | 12 Enter: confirmation (confirm the setting parameter values) |

Indicator light (beside utility and generator each has 3 indicator lights)

- 13 Four utility power supply mode, green indicator light
- 14 Four utility failure, red light flashing constantly
- 15 For power generation mode, green indicator light
- 16 For power generation failure, red light flashing constantly
- 17 When green light up, it shows power generation side breaker switch on
- 18 When red light up, it shows the utility side breaker switch on

Generating Set Operation

➤ After the inspection procedures are completed, the generator set can be put into operation:

A. Manual Operation	
(1)	Turn the key switch of the control screen to the "on" position to connect the control module with DC power switch (If the key is lost in an emergency, the circuit behind the key switch can be connected temporarily). The control module LCD screen works now.
(2)	Press "Module" button until the LCD screen shows "Manual" so that the module is in the mode of "Manual Operation"; Press "Start" button, the generator set will start the barring gear after the set delay time (0~600 s, adjustable); If it fails to start for the first time, the generator set will restart 15 minutes later. The generator set will start like this for 3 times all together. If all fail, it will stop the starting procedure and gives out an alarm. The generator set can be restarted only after the fail reasons are found. When 15 lights on indicator are the green color, the generator set is running normally
(3)	Confirm that the mains switch is disconnected (indicator 18 distinguishes) or the ATS switch is beside the alternator. Press the switching knob in the right side of the control screen. When indicator 17 lights is green color, the side switch of the generator set is turned on and the generator set supplied electricity to load normally.
B. Automatic Operation	
(1)	Turn the key switch of the control screen to the "on" position to connect the control module with DC power switch (If the key is lost in an emergency, the circuit behind the key switch can be connected

	temporarily).The control module LCD screen works now.
(2)	Press "Mode" button until the LCD screen shows "Automatic" so that the module is in the mode of "Automatic Operation".
(3)	If the mains are normal at the moment,the generator set will be in the ready mode (Indicator 13 and 18 lights).
(4)	If the mains are abnormal ,indicator 14 (red color) will blinks constantly.The generator set will start after the set delay time (0~600s,adjustable) when it receives mains failure signals.If the voltage and frequency reach their normal value after start,the switch will be turned on automatically and the generator set supplies electricity to the load.If it fails to start for 3 times,the generator set will initiate the procedures stated in the manual start procedures.

C Running Parameters of the Generator Set in Operation

(1)	When the generator set is in operation,parameters like "KW", "RPM", "HZ", "PF" can be read from the main screen.
(2)	Press" ↓" button to turn the page to mains voltage V ,mains current A,alternator voltage V,alternator current A,engine lube oil pressure Bar,engine coolant temperature °C ,fuel oil level 1 % (if the fuel tank is equipped with liquid level analogue sensor),and battery voltage V.
(3)	If the fault does serious harm to the generator set,such as low lube oil pressure and high water temperature,it will shown on the LCD screen.Press "HORN RESET" button to stop the alarm and turn the key switch to the "off" position to disconnect the DC power switch to solve the fault displayed on the screen,such as checking the lube oil level and changing the lube oil filter.After the fault is solved,the generator set can be restarted (If the DC power switch is still connected,press reset button "FAULT RESET").

D Shutdown

(1)	Manual shutdown:If the generator set is in the mode of "Manual Operation",when the mains recovers press the right alternator output switch separating button disconnect the return circuit.The output power of the generator set will be "0".Press the shutdown button "Stop",the generator set will automatically stop after the set cooling period (0~999s adjustable) in no load operation(If the generator set conduct the load near 100%,remove the load gradually before disconnect the generator set output switch,so as to avoid the rise of engine speed caused by sudden reduction of heavy load)
(2)	Automatic shutdown:If the generator set is in the mode of "Automatic Operation",when the mains recovers,the control model will receive the normal mains signal and disconnect the output switch

	automatically.The generator set will automatically enter the state of ready mode again.
(3)	Emergency shutdown: When the generator set is in operation,if any equipment related with the generator set may do harm to the equipment itself or people,press the red emergency stop button on the control panel or press the "Stop" button on the control module twice,then the generator set will stop running immediately.When the generator set stop generating electricity,the control module will give out an alarm and display "Emergency Shutdown".
E Generator Set Breakdown	
(1)	When breakdown or fault occurs,the integrated fault indicator on the control panel will light and the fault buzzer will give out a harsh alarm.
(2)	If the fault does no harm to the generator set,such as low fuel oil level,low battery voltage and three times start failure,press "HORN RESET" button to reset the alarm.After the fault is solved,such as adding enough fuel to the fuel tank,press "FAULT RESET" button to reset the generator set.In an emergency ,press the two buttons mentioned above can reset the generator set to generate electricity immediately.
(3)	Emergency shutdown reset:Rotate the emergency stop button clockwise with small angle,the button will bounce out.Then the generator set can be restarted.

2.9 Storage Battery

- Before using the start battery, you should buy a standard battery electrolyte. Open the top cover of the battery and add the electrolyte slowly till it reaches the scale mark on the internal plate (not higher). After adding the electrolyte, do not use it immediately. Keep the battery still for about 30~60 min. When the ambient temperature is low, extend the time (for details, refer to the Battery's Operating Instructions).
- Before using the no-maintenance battery, please measure its terminal voltage, when over 12.6V, can use it directly; or observe the charge state indicator on battery, for charge state display please refer to the related remarks on the battery. For low voltage or charge state indicates insufficient, please use it after charging.
- That is no need to add the water in the process of using no-maintenance battery.
- With the standard battery connecting line, you can connect the anode and cathode of the battery with the terminals on the start motor correctly (as shown in Fig.2-9). Most units don't allow the cathode to connect to the housing directly. For the unit equipped with two batteries, connect them together before connecting them with the unit (as shown in Fig.2-10).

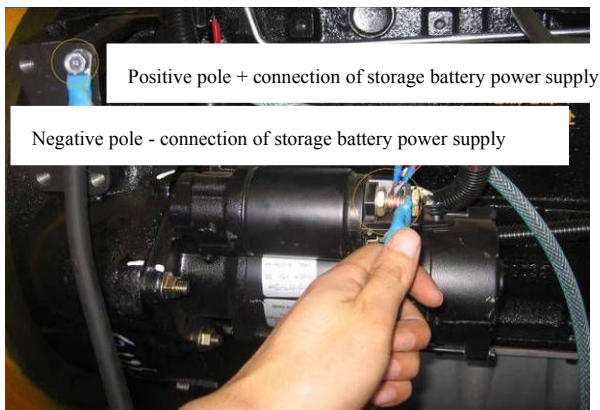

Fig.2-9

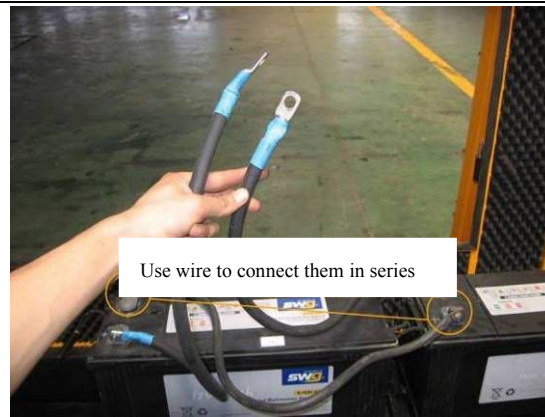

Fig.2-10

- The storage for start-up battery will decide whether the diesel engine can start smoothly or not in setting time.
- If starting the generator set stops, the utility will charge for the battery by floating device, which makes sure the generator set can start itself successfully after utility fails.
- The energy capacity of the start battery determines whether the diesel motor can start smoothly in the specified time.
- In the running process, the charge generator is responsible for charging the battery uninterruptedly.
- ⚠ **Make sure that the anode and cathode are connected correctly. Connect the anode first, then connect the cathode. If they are not connected in such sequence, fault will occur! (special attention must be paid when connecting the power line)**
- ⚠ **If disconnect the battery connection, remove negative pole firstly and then the positive pole!**
- ⚠ **Do not disconnect the battery connecting line when the unit is running!**

2.10 Power distribution system

- The electrical distribution output is realized by the plastic housing breaker that is on the side of the unit and matches with the capacity of the unit. This breaker is located in the air switch cover on the side of the unit. It can switch on/off by operating the handle directly. Its purpose is to protect the alternating-current generator from being damaged by the overload current or other abnormal impact. This breaker has high breaking capability and fault automatic tripping capability. When making the electrical connection, connect the electrical cable from the bottom of the breaker to the load directly.
- For the high power unit or combined unit, there is no plastic housing air switch in the air switch cover of the generating outgoing screen or combined screen. The generating output control protection is realized by the main breaker on the above screens.
- When installing the distribution output, you can connect the cable that meets the safe current carrying capacity to the generating outgoing screen or combined screen and make sure the generating output phase sequence is

correct.

- The unit requires that the unit base must be grounded safely. For the ground terminals, see the ground marks on the base (as shown in Fig.2-11).



Fig.2-11

2.11 Preheater

- As optional parts, air preheater, water preheater and engine oil preheater are available. The purpose of using the preheater is to make sure the unit can start quickly at low temperature or in emergency case.
- These three preheaters respectively heat the air, cooling water and engine oil so as to realize the purpose of starting at the low temperature.
- The preheater has been installed and tested before the unit leaves the factory. You only need to connect the relevant power supply (fuel) according to the requirements.

3. Operation

3.1 Check before operating

After the installation, the unit can be put into operation for power generation. In order to make sure the unit is operated safely and correctly and keep the equipment in good condition, before you start the unit every time, at least check whether:

- there are sundries on or around the unit;
- the coupling is firm, the control mechanism is flexible, and the crankshaft rotates smoothly without clamping stagnation;
- the air inlet and outlet channel of the alternator room are unblocked;

- The cooling system is normal, the water tank is full (if not, add water from the water inlet, as shown in Fig.3-1. The water added must be cooling liquid);
- the air filter indicates normally;
- the level of the lubricating oil is in the normal range (as shown in Fig.3-3) (if not in the normal range, add the lubricating oil from the filling hole, as shown in Fig.3-2)
- Add the clean lubricating oil till it reaches the “MAX” position. The level of the lubricating oil should not be lower than the “MIN” position;
- the fuel remained is sufficient and the oil supply valve is opened (loosen the exhaust bolt of the high pressure oil pump, exhaust the air in the fuel pipeline, tighten the exhaust bolt fuel filling opening cover, add the fuel, as shown in Fig.3-4);
- all electrical circuits (including charge and start circuits) are connected correctly with good contact;
- water or oil leakage exists on the pipe joints of the supply, lubricating and cooling systems;

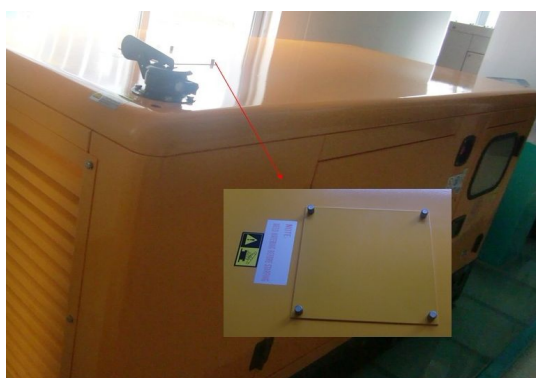

Fig.3-1

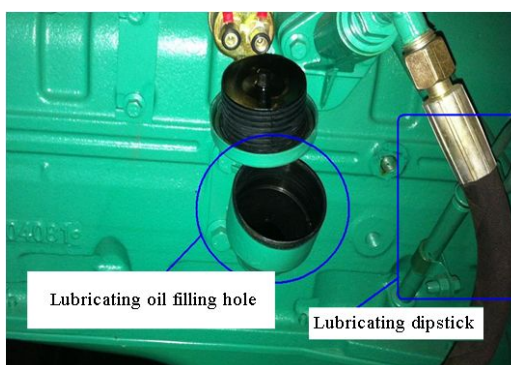

Fig.3-2

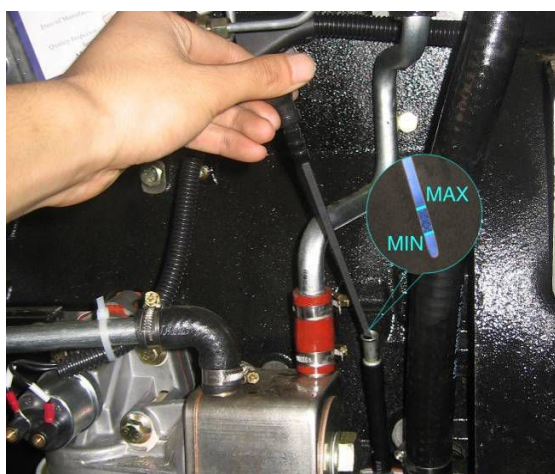

Fig.3-3



Fig.3-4

- Add the fuel into the oil pipe, operate the oil pump till there is sufficient oil in the oil pipe. For different motors, the position and operation method are different. Here, Lovol engine (as shown in Fig.3-5) and Cummins engine (as shown in Fig.3-6) are described. Continuously pump the oil manually with the high pressure oil pump

switch handle, till there is pumping resistance and the injector makes ringing sound.

Negative pole - connection of storage battery power supply

Use wire to connect them in

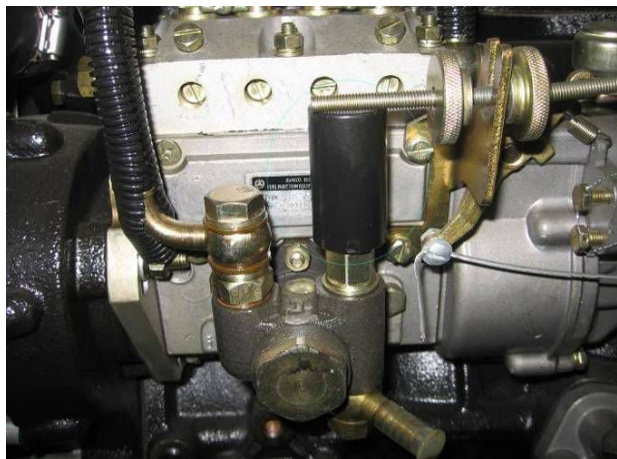

Fig.3-5



Fig.3-6

- the generating load equipment is well prepared, when the alternator has load directly, before starting it, the breaker must switch off It is forbidden that the unit starts in a loaded manner!
- the position of all switches on the control screen is normal, the main switch is in the switch-off position, the control screen with automatic pressure regulation is in the manual position;

⚠ The operator setting up good operation (maintenance) procedure is the basic premise that the unit can run without fault for a long time.

3.2 Operating

3.2.1 Power on

● turn the key switch on the control screen from the "OFF" position to the "ON" position (as shown in Fig.3-7). In this case, if the instrument background light on the panel becomes on, it indicates that the control screen is powered on. Check whether the initial values of all instruments or control screens are normal.

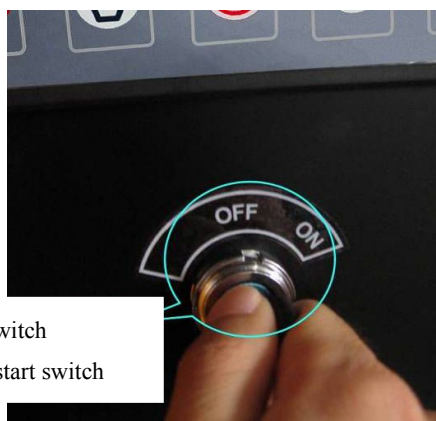



Power switch
Not the start switch

Preheat key

Fig.3-7

3.2.2 Manual Start and Shut down button of the Generator Set

- 1) Press the manual button , the controller will be in manual mode;
- 2) . Press the start button , the generator set will be in pre-heat state first (if configured), and then start;

⚠ Any damage of the generator set caused by force start without using the control panel is not under the scope of warranty.

- The start of the generator set is limited in three times. If the generator set fails to start for three times, the controller will send out a failure alarm and the generator set will not start again.
 - If the generator set is started successfully, it will enter the state of safe operation. During this period, alarms like low oil pressure, high water temperature, under speed and charging failure are invalid; After safe operation, the generator set will be in idle running..
 - When idle running is finished, the generator set will be in high speed warming up. After that, the controller will check and display the electrical parameters and the generator set running parameters. At this moment, the output circuit breaker is closed up, and the generator set is in normal running state and supplies power to the load.
- 3) To stop, should be removed load first, then press the stop button can be Normal shutdown, after high speed cooling, idle speed, the generator set is down.
 - 4) If the operation staff finds a serious abnormal breakdown in the generator set, he/she can press the emergency stop button (refer to the under diagram) to stop the generator set immediately. If there's no special circumstance, it is advised that the customer not stop the generator set by pressing the emergency stop button randomly.

3.2.3 Operation for starting and stopping automatically

- In manual operation, press the automatic button , controller will be automatic mode.
- When utility power is normal, the controller indicator light,generator set won't start.
- When utility power fails or becomes abnormal, by confirming abnormal start-up delay it will start the generator set automatically, which is the same as manual start.
- When the generator set starts successfully till the end of warm-up, after detecting the generator voltage is normal, there will be power switching signal and make ATS convert to the power generation side, the unit supply power to load.
- When the mains supply return to normal, get into mains voltage normal delay, and after confirming mains supply is normal, the switching signal will be send then control ATS shift to mains supply side, as a result,

electricity will be transported between mains supply and load. Meanwhile, through high speed heat dissipation, idle speed delay and stop delay, the generator set will get into standby condition for the preparation of self-starting.

- In the automatic mode, when the remote start signal is effective, the generator set will start to supply power to load according to above order. When the remote start signal is invalid, the generator set will be stopped according to above order.

3.2.4 Generator set operating Considerations

- 1) After the generator set has started, please check whether the gauge reading, the sound and the vibration is normal. If the generator set is break down, you should immediately stop the machine, it should be restart after fixing.
- 2) Always pay attention to water temperature 、 oil temperature and the change of oil pressure. If something abnormal, please stop the machine and check.
- 3) Have a regular inspection for fuel oil, engine oil, the storage of cooling water and cleanliness. Meanwhile, Check the engine oil spills, water leakage, air leakage, and other Abnormal phenomena;
- 4) Observe the color of diesel engine off-gas, normal color is cinereous, if the color is mazarine or black, please stop the machine and check.
- 5) It is strictly prohibited to water, oil, metal, or other foreign material into generator, three-phase voltage of the generator set should keep balance.
- 6) Always check the operation of the generator set, the gauge reading, the alarm indicator and the tank oil level. Regularly record the operating parameter of the generator set.
- 7) The generator set has a integrated protecting system. When some abnormal phenomena such as low oil pressure, high water temperature, over-speed, overvoltage and over-current, the protecting system can automatic alarm or halt. The user can judge the fault cause according to the information showed in the controller. After the trouble is removed, the generator set can be restarted.

3.3 After operating

- After the unit shuts down, it is necessary to conduct the following operations:
 - Check whether there is any three leakages (lubricating oil, fuel, cooling liquid);
 - Turn off the air inlet and outlet facilities of the alternator room (if necessary);
 - Turn off the output air switch of the alternator;
 - Turn off the power key switch on the control screen. Take out the key and keep it properly (if necessary);
 - For long-time shutdown or maintenance, remove the cathode cable on the start battery. Drain the fuel and cooling liquid when necessary.

- For the self-start unit, some of the above items are not applicable. After the self-start unit shuts down, keep it in the status before starting (standby status) so as to start at any time.

3.4 Examples for generator set configuration picture (Two Type Shown fig 3.8&3.9)

Open Type



Silent Type



Fig 3.9

3.5 Operating record

- Every time the unit runs, you must keep the running record. The running record has different forms. The basic content should include: running time, accumulated running time, readings of oil pressure gauge and thermometer in the running process, generating voltage, frequency and maximum power (current), unit running conditions,

fault alarm /shutdown etc.

△ With correct and complete running (maintenance) record, you can obtain fast and complete after-sale service.

Example: Running record:

Time	Record time	Voltage(V)	Current(A)			frequency(Hz)	speed	Water temperature(°C)
			A	B	C			
Oil pressure (Kpa)	Oil Level	Fuel Level (cm)	Battery voltage(V)			recorder	remark	

3.6 Precautions

- △ When the motor's temperature is too low, extend the idle running time as required. After the unit warms up, it is not allowed to keep the unit running at idle speed for a long time;
- △ It is not allowed that the unit keeps running with no or small load. Such running will result in serious carbon deposition and oil leakage on the turbine booster and exhaust system;
- △ It is not allowed that the unit runs overload for a long time, otherwise it will result in fault and short service life;
- △ It is forbidden to disassemble or replace the parts when the unit is running;
- △ Add the cooling liquid that is the same with that in the original cooling system. When opening the water inlet cover, prevent the personal injury by the steam or high temperature cooling liquid;
- △ Prevent being burnt when draining the high temperature lubricating oil;
- △ Use the fuel that meets the national standard, otherwise fault may occur on the oil injection pump or injector;
- △ For the motor with turbine booster, it is suggested not to make the unit bear above 50% accidental load, otherwise the unit will lose speed seriously. For the large-size power consumption equipments, it is suggested to control their start by reducing the voltage or changing the frequency to minimize the huge impact on the unit in the starting process;
- △ For the standby unit or the unit that does not run for a long time, it is suggested to run it to the working temperature every month and run it with full load for 4h or so every year, so as to burn the carbon in the motor and

exhaust system;

- ⚠ For the manual combined control unit, you can't turn off before making sure the synchronization (same frequency, phase sequence, phase and voltage). Before the shutdown, you must turn off first and then shut down. When the unit is running, keep it attended to prevent single fault shutdown.

4. Maintenance

4.1 General

- ⚠ In order to obtain optimal running safety and longest service life, regular maintenance is crucial. If the relevant maintenance instructions are followed strictly, you can make sure the unit's performance and avoid damage to the environment;
- ⚠ It is helpful to the maintenance correctness and operation safety to correctly identify and strictly follow the labels on the unit body (illustration, text, warning etc.);
- ⚠ The maintenance must be conducted when the unit shuts down. Remove the cathode cable of the start battery to make sure the unit will not start by improper operation.

4.2 Engine

Before starting the unit every time

- Check the level of the lubricating oil;
- Check the level of the cooling liquid;
- Check the clogged indicator of the air cleaner;
- Check the ventilation of the radiator;
- Check the driving belt set of the motor;
- Check the fuel supply;

- ⚠ **The unit that keeps running for a long time should be checked every 6~8h. The standby unit should be checked again after it shuts down. For specific units, please subscriber carry out correctly referring to related maintenance information for engine.**

4.3 Generator

- The inside and outside of the alternator should be cleaned regularly. Its frequency depends on the local environment. When cleaning is required, operate in the following steps: disconnect all power supplies; wipe out the dust, dirt, oil stain, water or any fluid; clean the air screen. Once they go into the coil, the coil will overheat or the insulation will be damaged. Absorb the dust and dirt with the vacuum cleaner. Do not clean them by blowing or high pressure water injection.

- In case of alternator dampening that results in lower insulation resistance, it must be dried. For the drying method and detailed maintenance, refer to the Alternator's Operating and Maintenance Instructions.

4.4 Control screen

- In the daily maintenance, make sure its surface is clean, the instrument displays definitely, and the operation buttons (keys) are flexible and reliable.
- In the running process, vibration will cause the zero position on the control screen instrument to deviate and the fastening parts to become loose. Therefore, it is necessary to calibrate the control screen and fasten the connecting parts and connecting lines regularly.
- Repair must be conducted after the principle is well understood (for details, refer to the Control Screen's Operating Instructions).

4.5 Start battery

- The battery that is stored for a long time must be charged properly before the use to make sure the normal capacity (detect its actual capacity with the gravimeter).
- Dry charge battery, normal operation and charge will cause some water in the battery to be evaporated. Therefore, add the electrolyte frequently. Before adding the electrolyte, first clear off the dirt around the filling port to prevent it falling into the battery; then open the filling port and add appropriate amount of distilled water or purified water. Do not add too much (to the polar plate scale). Otherwise, when the battery discharges/charges, the electrolyte will flow out from the overflow hole of the filling port, leading to corrosion to the ambient goods and environment
- No-maintenance battery should be charged after having been stored for above 3 months. The consumption battery in the process of using due to various reasons should be charged in time, in order to avoid reducing its performance because of the battery sulphation.
- Avoid starting the unit when the battery is at low temperature. The battery can't make normal output at the low temperature. Long-time discharge may result in battery fault (cracking or explosion).
- The standby unit battery should be maintained and charged regularly. It is suggested to buy the floating charger.

4.6 Maintenance record

Every time the maintenance is conducted, you must make detailed record.

⚠ Complete maintenance record is the basis that you maintain the unit, and also the indispensable conditions that the unit is provided with valid after-sale (warranty) service.

Example: Maintenance record:

by the material, design or manufacturing defect, we will select (determine) to provide repair or replacement. The fault parts should be returned to our dealer or factory duly.

All parts repaired or replaced within the warranty term will be returned by our company free of charge (for the region outside China, shipping will be made).

We will not bear any cost for transporting, replacing any parts sent to us for detection or installing the replacement parts furnished by us. For the fault and loss caused by failure to install, operate, maintain and store the unit as per the manual or repair by the technician not authorized by us, we will not undertake any responsibilities. For third party products not produced by us or patented products, though they are furnished by us, their quality should be warranted by their manufacturers (if any).

Any claim under the warranty conditions must contain the fault's detailed description, product description, purchase date, supplier name and address and product serial number (marked on the manufacturer's nameplate). If spare parts are involved, their order number should be furnished.

Considering that we repair or replace the above parts, we have fulfilled all responsibilities. In any case, our responsibilities should not exceed the prevailing price of the fault product.

These terms and conditions act as the supplement of the special quality warranties and conditions specified on this product by the laws. Other than this, we will take no responsibility for any fault, damage or loss (including the direct loss or the loss caused by other relevant work) of the delivered product, regardless of such responsibilities based on the contract, infringement or other reason.

Warranty Commitment

- 1) For all replace parts in the warranty period, Our company will send them free of charge.(We will choose sea transportation site is outside country)
- 2) For the third party products or patented products which are provided by us,
The warranty will be born by the manufacturers respectively(if any); we are liable to help customers to give a feedback and solve quality problems with relevant manufacturers.

Warranty Requirement:

- 1) Generally, we do not accept verbal notification. Every distributor and customer shall contact our After-sales Department or after-sales person through written form like email or fax, if any fault of generating set occurs
- 2) Once receiving the fault notice, we will contact the distributor or customer directly to check the relevant fault details, if needed, we will send our staff to the site for inspection and submit the relevant information to distributor. Then we will make necessary arrangement and deliver the needed parts

6. Troubleshooting

6.1 General

➤ Many factors may result in fault to the unit. The fault symptoms have obvious correlation. This section mainly summarizes and lists faults that may occur on the unit. It is only used for your reference during the troubleshooting (particularly important to the new user).

⚠ Note that most faults involve improper installation, operation or maintenance. You are entitled to doubt that the fault is caused by the unit itself. However, it must be based on the correct installation, operation, use and regular maintenance of the unit. Otherwise, the unit's normal use and running as well as the due after-sale service will not be guaranteed.

6.2 List of faults

Fault	Possible Causes	Solutions
The unit can't start	The capacity of the start battery is insufficient	Maintain the battery (charge it or add electrolyte). Replace the battery set when necessary
	The control screen is not powered on	Check the connection inside the control screen
	Some units (electric injection type) are powered on so fast but the electric injection controller does not pass the self-check	Restart after the control screen resets (wait for 3~4s)
	The start relay fails	Replace this relay
	The start motor fails	Analyze the reason and replace it when necessary
	The unit is jammed and barring can't be made manually	Check it thoroughly to find the reason
It is difficult to start the unit, or the start time is too long	The capacity of the start battery is insufficient	Maintain the battery (charge it or add electrolyte). Replace the battery set if necessary
	The preheating is insufficient before starting	Check the preheating element

	The start throttle potentiometer on some electric governor units is too small	Refer to the Electronic Governor's Operating Instructions. Make this potentiometer larger properly
	The unit is in the low temperature status	Try to increase the body temperature. It is suggested to use the heater
	The unit is in the plateau with rarefied air environment.	Do not start at one-time full speed. Keep the unit running at the idle speed for some time before adjusting to the full speed
	The fuel is not the suitable type for the machine.	Replace it
	Water exists in the fuel	Replace the fuel. It is suggested to install the oil-water separator
	The fuel system has air or has no fuel	Exhaust the air and make the fuel flow out of the oil return pipe normally by using the manual fuel pump
	The fuel cleaner is clogged seriously	Replace the fuel cleaner regularly
	The air intake system is clogged seriously	Replace the air cleaner regularly
	The oil injection pump and nozzle fails (clogged)	Check the oil pump and analyze the reason by the authorized technician. Most are caused by using nonconforming fuel for a long time
	The oil transfer pump fails	Check and repair it. Replace it when necessary
	The shutdown solenoid valve fails	Check and repair it. Replace it when necessary
	The exhaust system is clogged seriously	Check and solve the fault
	The electronic governor plate fails	Check whether it is powered on. Replace it when necessary
The unit can't keep running	Water exists in the fuel	Replace the fuel. It is suggested to install the oil-water separator

after starting	The fuel system has air or has no fuel	Exhaust the air and make the fuel flow out of the oil return pipe normally by using the manual fuel pump
	The fuel cleaner or air cleaner is clogged	Replace the three filters regularly
	The time of running at the idle speed in the rarefied air region is insufficient	Extend the running time at the idle speed properly to make sure the unit is warm up
	Fuel of incorrect type or grade is used	Replace the fuel and filters
Over speed occurs easily when the unit starts	The start throttle and climbing speed potentiometer of the electronic governor unit are adjusted improperly	Refer to the Electronic Governor's Operating Instructions. Adjust the throttle and climbing speed potentiometer slightly
	The over speed protection value is too low	Adjust the over speed protection value slightly, not higher than 17%
	For the mechanical governor structure	Check whether the throttle rod is flexible and make sure it is adjusted correctly
	The oil injection pump (system) fails	Check or repair it by the authorized technician
Fault	Possible Causes	Solutions
Black smoke appears when the unit starts	The air intake system is clogged	Replace the air filter regularly
	Fuel of incorrect type or grade is used	Replace the fuel
	The temperature of the motor is too low	Observe it after the motor reaches the normal temperature
	Rarefied air region on the altiplano	The motor should run at lower power on the altiplano
	The temperature of incoming gas is too high	The temperature of incoming gas should not exceed 40 °C
	The oil return pipe is clogged	Check and make sure the oil return pipe is unblocked

	The turbine booster is worn seriously	Check and repair it. Replace it when necessary
	The clearance of the air valve is incorrect	Check and adjust the clearance of the air valve
	The timing for oil supply is incorrect	Check the data of the oil injection pump and repair and adjust it by the authorized technician
Blue or white smoke appears	There is too much lubricating oil on the motor	Check the level of the lubricating oil
	Lubricating oil of incorrect type or grade is used	Replace the lubricating oil and cleaner and make sure to use the lubricating oil of correct type
	Fuel of incorrect type or grade is used	Replace it and make sure to use the fuel of correct type
	Water leaks on the cylinder head	Check the cylinder head and pad. Replace it when necessary
	The overhaul period of the motor comes	Overhaul the motor
The unit can't reach the rated rotation speed	The unit works in the overload status	Reduce the load, not exceeding the rated load
	The rotation speed potentiometer of the electronic governor plate is set incorrectly	Refer to the Electronic governor's Operating Instructions. Set it correctly or replace it
	The electronic governor system fails	Check, repair or replace it
	The throttle control of the mechanical governor mechanism is adjusted improperly (or loose)	Check and adjust it
	The fuel pipe is clogged (or too thin)	Check and repair (replace) it
	Water exists in the fuel	Replace the fuel. It is suggested to install the oil-water separator

	The three filters are not replaced duly	Replace the three filters regularly
	The frequency (rotation speed) gauge fails	Replace it
The unit is hunting	The throttle rod of the mechanical governor structure becomes loose	Check and adjust it to the correct position and fasten
	The electronic governor system is adjusted improperly	Refer to the Electronic Governor's Operating Instructions. Set the "grain" and "stability" potentiometer correctly
	The governor mechanism is out of control	Check and repair it by the authorized technician
	Air or water exists in the fuel system	Check and solve it (replace the fuel)
	The load fluctuates sharply and frequently	Try to control the load
The unit runs in an unstable and vibratory way	Air or water exists in the fuel system	Check and solve it (replace the fuel)
	The air cleaner is clogged	Replace the three filters regularly
	The lubricating oil is too much, or its grade is incorrect	Check the level of the lubricating oil or replace the lubricating oil and cleaner. Make sure to use the lubricating oil of correct type
	The temperature of the incoming air is too high	The temperature of the incoming air should not exceed 40°C
	The exhaust pipe is clogged (or the back pressure is too high)	Reduce the back pressure to make the motor's exhaust unblocked
	The oil injection pump (system) fails	Check or repair it by the authorized technician
	The clearance of the air valve is incorrect	Check and adjust the clearance of the air valve
	The cooling fan is damaged	Check and repair it. Replace it when necessary

	The foundation is not smooth and the installation position of the shock absorber is incorrect	Check and adjust the position
	The overhaul period of the motor comes ahead of schedule due to the rough use conditions	Overhaul the motor
Fault	Possible Cause	Solution
The pressure of the lubricating oil is too low	The level of the lubricating oil is incorrect	Check the level of the lubricating oil. Add or drain it
	The brand of the lubricating oil is incorrect	Replace the lubricating oil of correct brand and filter
	The lubricating oil is not replaced for a long time	Replace the lubricating oil regularly
	The lubricating oil cleaner is clogged	Replace the three filters regularly
The pressure of the lubricating oil is too low	The temperature of the lubricating oil is too high	Check, repair or replace the lubricating oil cooler
	The crankshaft bearing is worn or damaged	Check, repair or replace it and find the reason
	The relief valve is damaged	Replace the relief valve
	The oil suction filter of the oil sump is clogged	Check, repair or replace the oil suction pipe and clean the oil suction filter
	The alarm switch (sensor) or instrument of the lubricating oil fails	Check the control screen, instrument and body sensor. Repair or replace it, and solve the fault
The temperature of the cooling liquid is too high	The cooling liquid is insufficient	Add the cooling liquid
	The radiating rib of the radiator is clogged	Find the reason. Wash the radiator
	The radiator is not well ventilated	Increase the effective ventilation area according to the installation requirements in order to keep good ventilation

	The cooling fan does not run normally	Check the tension of the fan belt. Replace the belt if necessary
	The fan is damaged	Check, repair or replace it
	The pump is damaged	Check, repair or replace it
	The thermostat fails	Replace it
	The oil injection pump fails	Check, repair or replace it by the authorized technician
	The timing for oil supply is incorrect	Check the data of the oil injection pump and repair and adjust it by the authorized technician
	The ambient (air intake) temperature is too high	Keep the alternator room ventilated and reduce the temperature of the alternator room reasonably
	The unit is overloaded seriously	Control the load. It is forbidden that the unit keeps running overloaded for a long time
	The alarm switch (sensor) or instrument of the cooling liquid fails	Check the control screen, instrument and body sensor. Repair or replace it, and solve the fault
The fuel consumption exceeds the standard	The external or internal fuel leaks	Check and solve the leakage
	The air cleaner is clogged	Replace it regularly
	The air on the altiplano is rarefied	Keep the unit running at lower power
	The temperature of the motor is too low	Add with preheater as needed
	The unit is overloaded seriously	Control the load. It is forbidden that the unit keeps running overloaded for a long time
	The exhaust pipe is clogged (the back pressure is too high)	Check the exhaust pipe and control the back pressure
	The timing for oil supply is incorrect	Check the data of the oil injection pump and repair and adjust it by the authorized technician
	The clearance of the air valve is incorrect	Check and adjust the clearance of the air valve
	The overhaul period of the unit comes	Overhaul the unit

The unit's power output is insufficient	The unit is overloaded compared with the rated power	Reduce load running
	The altiplano region causes insufficient power	Correct the power when the altitude exceeds 1000m
	The fuel pipe is too thin or clogged	Check and increase the diameter of the fuel pipe and reduce the resistance of the fuel pipe
	The fuel is not the suitable type for the machine	Replace the fuel and cleaner and make sure to use the fuel of correct type
	The oil return pipe is clogged or the oil tank exhaust hole is clogged	Check and solve the fault
	The exhaust pipe is clogged (the back pressure is too high)	Check the exhaust pipe and control the back pressure, increase the pipe diameter
	The air intake is insufficient (the air filter is clogged)	Replace the air filter regularly
	The temperature of the air intake (alternator room) is too high	Check the intake location of alternator room and cut off the heat source, Keep the alternator room ventilated and reduce the temperature of intake air reasonably
	The temperature of the fuel is too high	Try to control the temperature of intake fuel <70℃
	The oil injection pump or governor system fails	Check, repair or replace it by the authorized technician
	The impeller of the turbine booster is damaged or fails	Check, repair or replace it
The clearance of the air valve is incorrect	Check and adjust the clearance of the air valve	
Fault	Possible Cause	Solution
	The timing for oil supply is incorrect	Check the data of the oil injection pump and repair and adjust it by the authorized technician
	The overhaul period of the unit comes	Overhaul the unit

The unit can't shut down	For the self-start unit, though ATS start signal cuts off, the unit still keeps running	It is normal. The unit shuts down after going into the cooling running
	The shutdown solenoid valve is out of control	Check whether the circuit is connected correctly. Replace the solenoid valve when necessary
	The electronic (mechanical) governor fails	Check and repair it by the authorized technician
The unit can't shut down	First turn off the key switch, then press the shutdown button	It is incorrect operation. First press the shutdown button, then turn off the key switch
	The control instrument of the engine fails	Check, repair or replace it
	There is no fuel or water or air exists in the fuel	Check and solve it. It is suggested to install the oil-water separator
	The fuel or air cleaner clogged	Check and replace the three filters regularly
	The electronic governor fails	Check and repair it by the authorized technician
	The shutdown solenoid valve protects the shutdown action	Check the alarm content (code) and solve the shutdown fault
	The control screen (system) fails	Check and repair the control screen according to its Operating Instructions
Breaker failure	The circuit breaker turns off automatically	The air switch turns off due to the unit overload (short circuit)
		The electronic brake for the combined control turns off
		The unit brake itself fails. Maintain and replace it
	The circuit breaker can't turn on	After turning off due to overload (short circuit), it can't turn on before triggering again
		It can't turn on if not in step for combined control
		The unit brake itself fails. Maintain and replace it
The control screen fails	The unit alarm shuts down	The control screen detects the unit fault and shuts down. Solve the fault and restart it after power-off (reset)

	The unit can't start when the utility power fails	ATS does not provide "start" signal. Check and solve the fault
		The self-start engine instrument must be powered on and works in the "automatic" status
		The control line is connected incorrectly. Check and change the connection.
		The self-start engine instrument fails. Check, repair or replace it
	The unit can't shut down when the utility power is normal	The unit is in the cooling running status (3~5min)
		ATS provides "start" signal without shutdown. Check the ATS fault
		The engine instrument sets the oil circuit electromagnetism incorrectly
	The remote monitoring and control can't be realized	Check whether the unit is configured to the "three-remote" control
		Check whether the communication circuit is connected correctly
		Check whether the communication software is installed correctly on the control network computer
Whether the communication is set by the correct monitoring and control password		
The "three-remote" engine instrument fails. Check, repair or replace it		
Voltmeter not show	(1)voltmeter loop fuse broken (2)Voltmeter loop wirings drop (3)Poor switch or voltmeter	<ul style="list-style-type: none"> ● Replacement ● Check and correction ● Replacement

Not reach rated voltage	(1) too slow engine rotation speed (2) Not proper voltage setting (3) loading over the rated value (4) Excitation circuit wiring loose (5) Generator internal fault (6) AVR fault	<ul style="list-style-type: none"> ● Adjust to the rated speed ● Adjust voltage setting knob ● Reduce to rated value ● Check the excitation circuit, correction ● Inform tatung company ● Inform tatung company
Voltage over rated value	(1)Not proper voltage setting (2)AVR terminals loose (3)loaded with Capacitive Load	<ul style="list-style-type: none"> ● Adjust the voltage setting ● Check each terminal and correct ● Remove
Unsteady voltage	(1) poor AVR	<ul style="list-style-type: none"> ● Inform our company
No power	(1)Excitation circuit wiring loose (2)Magnetic machine without residual magnetism (3)poor generator or excitation (4)rectifier is burned (5)AVR is burned	<ul style="list-style-type: none"> ● Check each terminal from exciter field line to AVR ● Check the terminal of initial exciting loop. the break over condition of resistance or rectifier etc ● Inform tatung company ● check and replace rectifier ● Replace AVR



7.Controller Handling Procedures

1.INSPECTION PRIOR TO OPERATION

Prior to operating the generator set, be sure to inspect the following items to prevent trouble and accidents;

- 1) Check the specified specification and amount of engine oil and engine cooling liquid have been supplied.
- 2) Check that specified amount of fuel is in the tank.
- 3) Check the tension of the fan belt and charging generator driving belt.
- 4) Check that the CIRCUIT BREAKER is turned “ OFF”.
- 5) Check that the small CIRCUIT BREAKER in the electrical box is turned “ON”.
- 6) The generator set should be grounded

2. MANUAL OPERATION

- 1) Press the  button to enter the manual mode ,then the LED lamp is lighting up.
- 2) Press the start button  , the generator set will be started after preheating(if configured) several minutes . After starting successful,the generator is in the normal running after idle speed(if configured) and high-speed warm-up several minutes.
The start of the generator set is limited in three times.If fails,the starter motor will power off automatically. Next start will be tried after setting time delay.If three times try are fail , the generator set will stop and the controller will send out a failure alarm.
- 3) Check the voltage and frequency after running normal.If abnormal,please adjust them
- 4) Turn the CIRCUIT BREAKER to “ON” to supply power to the load.
- 5) Stopping the generator set : Turn the CIRCUIT BREAKER to “off” before stopping the generator set,then press the  button and the generator set will stop immediately.

3. AUTOMATIC OPERATION

- 1) Press the  button to enter the manual mode ,then the LED lamp is lighting up.
- 2) The generator set will start automatically when the remote start signal is effective or the utility power loses efficacy.
- 3) The generator set will stop after unloading and cooling 30-180 s when the remote start signal eliminates or the utility power is effective.

4 OPERATION CAUTIONS

- 1) If a heavy current due to overload of short-circuiting flows for extended periods, the CIRCUIT BREAKER may be turned “OFF” . In this case, check the cause of trouble and repair the defective parts. The CIRCUIT BREAKER cannot be reset unless it is once turned “OFF” .
- 2) This machine is equipped with EARTH LEAKAGE RELAY. When EARTH LEAKAGE RELAY is operated, “CIRCUIT BREAKER” is shut off to announce earth leakage after red lamp on the “RELAY” is lighted up. In the case, after checking the cause of earth leakage for confirmation, push “RESET BUTTON” on the “RELAY” and turn “ON” the CIRCUIT BREAKER, usually, green lamp is lighting up.
- 3) If the fuel system has air,please remove the air according to the generator set manual ,and then start generator set.
- 4) The generator set is equipped with “DOOR SWITCH”,when it is running,the generator set will Shut-down emergency if the both sides of door open. If the “DOOR SWITCH” function need to be removed,please turn the remove button to “0”.

