



LLC «SPF «VYMPEL»



OKP 42 1551

Approved
VYMP2.891.001-AS

CALIBRATION SYSTEM «CONG»
Operational Manual

VYMP2.891.001 OM

Dear Customer!

We are glad that you have purchased the calibration system “CONG” manufactured by “Vympel”.

Perhaps you are an experienced user of the instruments manufactured by our firm, or this is your first instrument manufactured by «Vympel».

Any case we kindly ask you not to put aside the present manual without studying it thoroughly.

We are confident that this operating manual contains information that will be use to you.

The information contained herein is the result of our expertise and many years of experience.

The manufacturer states that the product supplied complies with the technical data given in the present manual and meets safety and quality requirements.

No part of this manual may be reproduced or recorded in any search system or transferred and passed on to any third party in any form (using mechanical, photocopying, recording and other means) without the prior written consent of the manufacturer. The present publication gives no licenses concerning the application of the manufacturer’s technology.

Please read the present manual attentively, paying attention to the restrictions, directions and recommendations contained in it.

Please contact us regarding functional or design flaws as well as any suggestions and remarks you may have concerning this operating documentation at:

LLC «SPF»Vympel»

LLC «TC «Vympel»

Legal address:

410002, Russian Federation,
Saratov, Moskovskaya St., 66

Legal and postal addresses:

119121, Russian Federation,
Moscow, Pervyy Vrazhskiy
Pereulok, 4.

Tel.: (8452) 27 80 05

Fax: (8452) 74 02 85, ext. 113

Tel: (499) 255 85 63

Fax: (495) 933 29 39

Postal address:

410031, Russian Federation, Saratov, a/b 401

E: info@npovympel.ru

E: cong-prima@renet.ru,

saratov@npovympel.ru.

<http://vympel.group>

We wish you every success in your work!

Contents

1 Description of the system	4
1.1 Function of the system	4
1.2 Completeness	4
1.3 Technical specifications	5
1.4 Description of the construction and device operation	5
1.5 Marking and sealing	7
1.6 Packing	7
2 The System Software Program	8
2.1 Management of the system operating modes	8
2.2 Terms for SSP usage	8
2.3 Installation of SSP	8
2.4 Work with SSP	8
3 The System operation	13
3.1 General	13
3.2 Safety requirements	13
3.3 Preparing the system for operation	13
3.4 Work with the system	14
4 Technical maintenance	15
4.1 General	15
4.2 Performance of external examination	15
4.3 The system calibration	15
5 The current overhaul of the system	17
5.1 General	17
5.2 List of possible faults of the system	17
6 Storage	19
7 Transportation	19
7.1 General requirements for transportation	19
7.2 Transportation terms	19
8 Utilization	19
Appendix A (mandatory) Methodology for system preparation to calibration of “CONG-Prima” series devices	20
Annex B (recommended) Logbook for operating files, faults and failures	21

The aim of this manual is to give information about construction and operating principle of the calibration system “CONG” VYMP2.891.001 (hereinafter – system, device) and rules for operation.

We ask you to take into account that technical perfection of the device can sometimes lead to not principal divergences between construction, electrical circuit of the device, and current manual, while keeping technical specifications in accordance with technical terms VYMP2.891.001 SP.

1 Description of the system

1.1 Function of the system

The calibration system “CONG” is destined for usage as a standard measure of moisture content when performing graduation and calibration of dew point gauges of series “CONG-Prima”.

The system is a stationary, continuously operating device for getting gas-vapor mixture with the assigned humidity, based upon the equilibrium method.

The system is destined for operation in explosion-proof zones of premises.

1.2 Completeness

The complete set of delivery is given in Table 1.

Table 1

Designation	Name	Q-ty
VYMP2.574.001	Thermohygrostate	1
VYMP 4.841.009	Cable	1
	Portable computer Pentium with the set operational system and fitting kit of the operating system MS Windows'98 or higher	1
SCZ-1	Power cord	1
	Modem cable DB9F-DB25M, 1,8 m	1
EL204-1	Interface transducer RS485/RS232/USB	1
VYMP 4.161.005	Packing	1
VYMP 8.054.001	Cover (from composition KPAY2.574.001)	1
VYMP 6.970.030	Thermocalibrator (technological appliance with the built-in standard thermometer of resistance to platinum low-temperature PTSV-2, TU4211-020-02567567-2007)	By specific order
Set of documents		
VYMP2.891.001 OM	Operational manual	1
RU.C.31.004.A №43258	Certificate of approving measuring instrument type	1
VYMP2.891.001 VP	Verification procedure	1

1.3 Technical specifications

Table 2

Name of parameter	Value
Range of reproducing the dew point, °C	From minus 50 till plus 30
Limits of admissible absolute error at reproducing the dew point, °C, max	±0,5
Response time to reproduction mode of the dew point assigned value, min, max	30
Supply voltage of thermohygrostatic chamber, V	From 187 to 242, (50±2) Hz
Full consumed power of thermohygrostatic chamber, V·A, max	30
Overall dimensions of thermohygrostatic chamber, mm, max	122×190×270
Weight of thermohygrostatic chamber, kg, max	4
Terms for operation:	
- air temperature, °C	From – 10 to +35
- relative air humidity, %	Up to 80 at temperature +35 °C and lower temperatures
- air pressure, kPa	From 84 to 106,7
Mean time between failures, h, max	20000
Mean lifetime, years	10

1.4 Description of the construction and device operation

1.4.1 The complex is a stationary continuously operating device for getting vapor-gas mixture with specified humidity, which is based upon equilibrium method.

1.4.2 The calibration system consists of (figure1):

- thermohygrostatic chamber (pos.1);
- computer with a special software (pos.4).

1.4.3 Thermohygrostatic chamber mechanism

Thermohygrostatic chamber consists of the standard chamber (figure 1, pos. 2), power source and matching electronic block, assembled into one case. At installation of dew point transducer (pos. 3) (without sampling mechanism) onto the standard chamber, the confined space is formed between the chamber and transducer sensor, where the required dew point is achieved by means of forming the hygrothermodynamic equilibrium between the vapor and condensed water phases.

1.4.3.1 Standard chamber

At installation of the calibrated dew point transducer onto the flange of the standard chamber, the confined space is formed, where a condensation mirror locates, temperature of which can be regulated by means of thermoelectronic battery (TEB). On the end of the standard chamber there are two fittings with plugs. They are used for technological purposes at the stage of production. When performing check and calibration of dew point transducers on the complex, plugs shall be tightly closed.

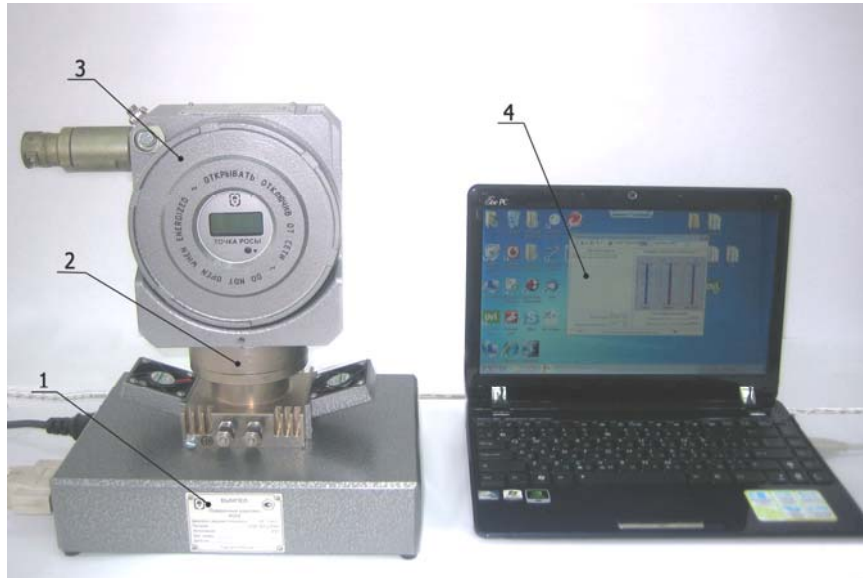

Figure 1 – Calibration system «CONG» together with dew point transducer of series «CONG – Prima»

1.4.3.2 Power source

Power source transforms AC voltage 220V 50Hz to DC voltage 24V that is used for power supply of the matching electronic block and calibrated transducer of series “CONG-Prima”.

1.4.3.3 The matching electronic block

Functional scheme of the matching electronic block (EB) is given in figure 2.

The electronic block performs the following functions:

- measurement of thermistor resistance of the standard chamber case and condensation mirror;
- measurement of the output current signal 0...24 mA of the calibrated dew point transducer;
- supply of the constant current to TEB, value of which is prescribed by external computer;
- transfer of measured data to the external computer.

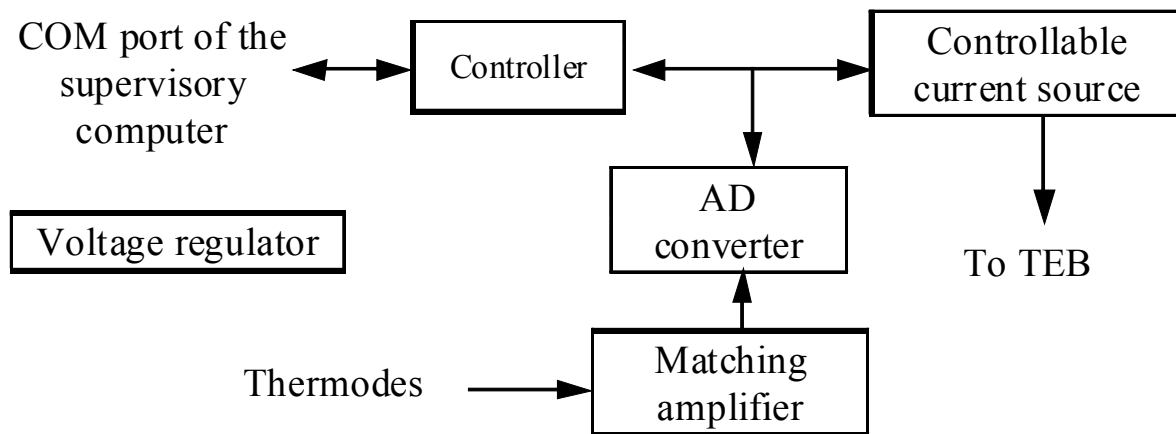

Figure 2 – Functional scheme of EB

Voltage regulator transforms input voltage +24V to voltage +8V, used for supply of current stabilizer, and ± 5 V for supply of integrated circuit. The input stage provides matching of signal levels of the computer port and EB microelectronic circuit.

The controllable current source provides supply of constant current to TEB, value of which is prescribed by external computer. It includes the integral AB converter (ABC), transducer “voltage – current”, assembled on the operational amplifier and transistor power amplifier.

The external computer controlling the ABC output voltage can change value of the current supplied power to TEB, within minus 600 mA and +2,6 A.

Measurement of thermistor resistance and current signal 0...24 mA is provided by ABC. It consists of 12-discharge eight-channel ABC and integral source of voltage reference. Switching of measurement channels and taking measurement readings are performed by external computer.

The matching amplifier transforms resistance of thermistors into voltage, value of which does not exceed the input range of ABC while temperature is changing from minus 50 °C to plus 50 °C. It consists of two current generators for power supply to thermistors and two voltage amplifiers.

1.5 Marking and sealing

1.5.1 On the thermohygrostate case the table shall be mounted with the following information:

- manufacturer's name and its registered trade mark;
- name of the system;
- system's serial number according to the numbering convention of manufacturers;
- sign for approving the measuring instrument type;
- unified circulation mark in the market of the Customs Union states – members;
- marking of protection degree by GOST 14254-15 (IEC 60529:2013);
- parameters for power supply;
- limit values of the dew point formed by the system.

1.5.2 On the thermohygrostate case nearby the ground screw there is the earth sign.

1.5.3 Electronic boards of the thermohygrostate, located inside the case, are covered with the cap and sealed by the manufacturer.

1.6 Packing

1.6.1 The system packing shall be made according to the manufacturer's drawings, in closed ventilated premises at air temperature from +15 till +40°C and relative air humidity up to 80% when there are no any aggressive impurities in the ambient air.

The thermohygrostate packing provides integrity of the device and spare parts and accessories set when performing handling operations, transportation and storage, and protection against impact of climatic factors and mechanical loads as well.

1.6.2 Computer Notebook PC is delivered in the manufacturer's packing.

1.6.3 Thermohygrostate packing contains facilities for its amortization in the shipping container.

1.6.4 Operational and shipping documentation is wrapped by water-proof material and put into the shipping container.

2 The System Software Program

2.1 Management of the system operating modes

2.1.1 Management of the system operating modes is made by means of computer with a special software program (hereinafter SSP).

SSP performs the following functions:

- automated support of the prescribed dew point;
- representation of the controlled variables' values;
- protocolling of the work.

2.2 Terms for SSP usage

Work with SSP is guaranteed on computers with operational system Windows Vista, Windows XP, Windows NT, Windows'9x.

2.3 Installation of SSP

Launch file «cong.exe» from the installation compact-disc and follow the further instructions of the installation wizard. The installation wizard will create folder “CONG” in section “Programs”, Start menu. In this folder there will be tags for programs “Wingen.exe” (program of the system management), “Prcal.exe” (program of the system calibration), “Pview.exe” (program for review and printing reports) and “Удаление КОНГ» (“CONG Cancellation») (program for SSP removal). If required you can copy tags to the desktop.

2.4 Work with SSP

To launch SSP, click the program label “Управления комплексом КОНГ” (“Management of CONG system”) which after installation will be located in section “Programs”, menu “Start”, or launch “Guide”, enter folder “C:\CONG” (or one that you have chosen while installation) and launch file “Wingen.exe”. After launching the program, box “Control panel by calibration system CONG” shown in figure 3 will be opened.

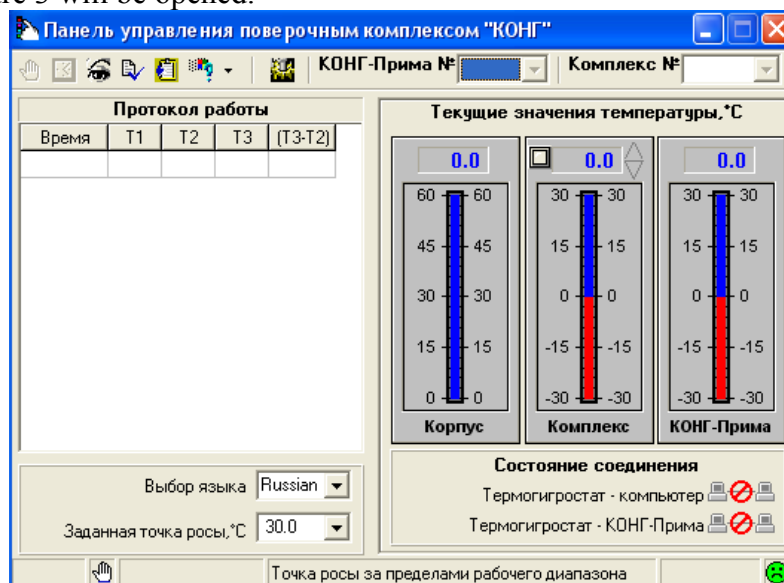









Figure 3 – Control panel

2.4.1 Control panel contains the following elements of management and indication:

a) control buttons performing the following functions:

- | | |
|---|---|
|  | Transition to manual operation; |
|  | Transition to automated operation; |
|  | Review of history; |
|  | Activation of information about system settings; |
|  | Activation of the box “Список приборов “КОНГ-Прима” (“List of CONG-Prima devices”); |
|  | Activation of Help topics; |
|  | Transition to the mode of system calibration; |

b) field “КОНГ-Прима №” (“CONG-Prima No”) shows a serial number of dew point transducer of “CONG-Prima” series, checked in the system. This number is chosen manually in the list opening with button ;

c) field “Комплекс №” (“System No”) shows three last figures of the system’s serial number, connected to the computer;



d) field “Выбор языка” (“Language selection”) allows to change language of dialogue with the user;

e) field “Заданная точка росы” (“Prescribed dew point”) (see item 2.4.2 “Manual mode of the system operation”);

f) display control panel “Текущие значения температуры” (“Current temperature values”) shows the following temperatures in digital form and on scale indicators:

- 1) “Корпус” (“Case”) - temperature of the thermohygrostate case;
- 2) “Комплекс” (“System”) - a dew point reproduced by the system;
- 3) “КОНГ-Прима” (“CONG-Prima”) - a dew point, measured by device of “CONG-Prima” series.

Readings are taken by the current output of “CONG-Prima” series device;

g) panel “Состояние соединения” (“State of connection”) shows the presence (symbol ) or absence (symbol ) of connection between the computer and thermohygrostate, and between device of “CONG-Prima” series and thermohygrostate;

h) panel “Протокол работы” (“Protocol of work”) shows protocol of the system work with the following information:

- 1) in column “Время” (“Time”) there is time of recording the protocol line;
- 2) in column “T1” there is temperature of the thermohygrostate case;
- 3) in graph “T2” there is a dew point reproduced by the system;
- 4) in graph “T3” there is a dew point measured by device of “CONG-Prima” series.

Indications are taken by the current output of the “CONG-Prima” series device;

5) in graph “T3-T2” there is a variable of the dew point deviation value, measured by the connected transducer of “CONG-Prima” series, from the variable reproduced by the system. It is calculated by formula $(T3-T2)$;

6) the status bar (it locates in the lower part of the control panel) contains information about the system current mode and operating time, and diagnostic messages as well (see “Manual mode of the system operation”). The current mode of the system operation is shown in the status bar by image of the sign for the analogous control button invoking this mode.

2.4.2 Manual mode of the system operation

The system transfers to this mode after launching SSP and performing self-diagnosis. Self-diagnosis involves inspection of the system temperature regulator operation, in the status line while that the message “Wait, the system diagnostics is proceeding” (“Подождите, идет диагностика комплекса”) emerges.

In the manual mode the system reproduces the dew point, value of which has been established in the field “Заданная точка росы” (“The preset dew point”) (this value is equal to the upper limit of the operating range when launching the manual mode).

To change the dew point one shall:

- hover a mouse cursor over the field “Заданная точка росы” (“The preset dew point”);
- click the left button of the mouse;
- to type a new value;
- press button “Enter” on the keyboard;
- or choose the dew point value from the list that is opened with a key-button .

After that the system starts transition to the new value of the dew point – in the status bar the message “Стабилизация” (“Stabilization”) will appear and notification-icon on the indication panel “Комплекс” (“System”)  starts to blink in red. When the preset dew point will be reached, the message “Измерение” (“Measurement”) will appear in the status bar and blinking of the notification-icon will stopped.

Value of the preset dew point shall not exceed $(T_k - 5,0) \text{ }^\circ\text{C}$, where T_k is temperature of the thermohygrostate case. In case of this term violation, the message “Точка росы за пределами рабочего диапазона” (“Dew point outside the limits of the working range”) will appear.

After outlet of the system to mode “Измерение” (“Measurement”), data registration on the panel “Протокол работы” (“Activity log”) starts. Period of data registration depends on the mode of the device “CONG-Prima-10” operation. If calibration mode (CAL on) is switched on the device “CONG-Prima-10”, the device will give pilot signal after each measurement (pilot signal is the current impulse with value 24 mA, duration 2 sec at the current outlet) and the system will register data with frequency of the device measurement after receiving the pilot signal. If mode of the digital data transfer is switched on the device “CONG-Prima-10”, the system will also register data with frequency of the device measurement after completion of digital transfer (identification of the “CONG-Prima-10” number while that will take place automatically). If neither of such modes is switched on the device “CONG-Prima-10”, the data will be registered in a period of 6 minutes, and message “No pilot signal” will appear in the status bar. Way of data registration is shown in the status bar by one of the following notification-icons:



Registration by digital transfer;



Registration by pilot signal;



Registration by time.

Protocol in the manual mode is not saved on the computer hard disc, data will be lost while closing the program.

In the manual mode, time of the system operation is displayed in the status bar (on the right).

2.4.3 Automated mode of the system operation

Automated mode means consecutive reproduction of some dew point values by the system without operator’s interference. To launch such mode, press key-button “Переход в автоматический режим” (“Transfer into automated mode”). The box “Параметры автоматического режима” (“Settings of the automated mode”), which contains the table of the automated mode settings, and buttons of editing and control as well, will be opened. The table will have two graphs – “Точка росы” (“Dew point”) and “Время выдержки” (“Persistence Time”). In graph “Точка росы” (“Dew point”) the dew point values are set ($^\circ\text{C}$), that will be consequently, starting from the upper line of the table, reproduced by the system for the period (min) preset in graph “Время выдержки” (“Persistence Time”). Persistence time for each dew point shall be min 60 min for devices “CONG-Prima-4” and “CONG-Prima-10”.

You can change, if required, setting values, using the following buttons for editing:



«To add» - to add a new line into the table;

«To delete» - to delete the light line from the table;

«To remember» - to remember changes in the display line;

«To cancel» - to cancel changes in the display line;

«Cleaning» - to delete all lines from the table.

Note – After pressing button “To remember” sorting of the automated mode settings in ascending order of the dew point value is performed.

After adjustment of the automated mode settings push button “Пуск” (“Start”), and you will see the box “Заголовок файла истории автоматического режима” (“File header of the automated mode history”), with the aid of which header of the history file will be created.

The history file will be saved on the computer’s hard disk and will contain the copy of data from panel “Протокол работы” (“Activity log”) from the beginning of the automated mode and up to its end. After completion of the automated mode the history file can be seen in the box “Просмотр истории” (“Review of the history”).

The history file header by default consists of data and time of starting the automated mode, and also number of the checked device chosen in the current session in the field “КОНГ-Прима №” (“CONG-Prima no.”) on the control panel. You should only add the header with your comments in the field “Комментарий пользователя” (“User’s comments”) to facilitate subsequently searching the file of your interest while reviewing.

After input of the history file header press a key button “Применить” (“To apply”) – the system will be transferred to the automated mode saving measurement results in the history file. If device “CONG-Prima-2” with the switched on mode of digital transfer is installed in the system, you may not to press button “Применить” (“To apply”) – the mode will start after receiving digital data.

After starting the automated mode, you may close the box “Settings of the automated mode” (“Параметры автоматического режима”) clicking the button “Выход” (“Exit”). You can come out of the automated mode pressing the key button “Переход в ручной режим работы” (“Transfer to the manual mode”) on the control panel or button “Stop” in the box “Settings of the automated mode”.

In the automated mode all key buttons are not available, except of buttons “Переход в ручной режим работы” (“Transfer to the manual mode of work”) and “Вызов справки” (“Help Topics”).

In the automated mode, in the status bar the total time of work in the automated mode (on the right) and the remained persistence time for the current dew point (on the left) are shown.

Upon completion of the automated mode the system transfers to the manual mode of work.

2.4.4 Mode of the system calibration

This mode of work is used only at the performance of the system calibration. In this mode the system ceases the process of the dew point reproduction, but it continues to measure and display the current temperature values on the indication panel “Текущие значения температуры” (“Current temperature values”). For coming out of the mode, switch off power of the thermohygrostate for some seconds.

2.4.5 Выход “Информация о настройках комплекса” (“Information of the system settings”)

This box can be induced by the key-button “Настройки” (“Settings”) on the control panel and contains information about the system’s factory settings. The user has the opportunity to adjust the current input and the system’s operating range.

Setting of the system’s current input shall be made by the current output of the calibrated device of the “CONG-Prima” series. To adjust the current inlet of the system, press key-button “Калибровка токового входа” (“Calibration of the current inlet”) and perform instructions which will appear in dialogue boxes. After performance of the next instruction make a pause for 10-15 sec to stabilize measurements and press button “OK”. In case of emerging the message “Калибровка не выполнена” (“Calibration has not been performed”), check efficiency of the current outlet of the series “CONG-Prima” device and repeat calibration. Calibration of the system current inlet shall be made again when changing the calibrated device of the “CONG-Prima” series.

The operating range of the system shall match the range of the current outlet 4...20 mA of the calibrated dew point transducer of the “CONG-Prima” series (from minus 50 till plus 10 °C or from minus 30 to plus 30 °C). To change the operating range of the system, enter a value of the range lower limit into field “min”, and value of the range upper limit into field “max”, and press key-button “to change the range”.

2.4.6 Выход “Просмотр истории” (“History Review”)

This box functions for review of history files, formed in the automated mode of the system operation. In the box there is a list of only those history files that have been made for the “CONG-Prima” series device with a number chosen in the field “КОНГ-Прима №” (“CONG-Prima No”) on the system control panel.

The box “Просмотр истории” (“History Review”) can be activated by the analogous key-button on the control panel and contains:









- field “Выбор файла истории” (“Selection of the history file”) that allows to select in the list the history file of your interest by its header;
- panel of digital data that is fully analogous to panel “Протокол работы” (“Activity log”) of the control panel (data received during the first 20 minutes after each change of the dew point are highlighted with yellow, they are not used at formation of the report concerning the “CONG-Prima” series device check in the system in the automated mode);
- panel of graphic data, where digital data (T1, T2, T3) are presented in the form of graphs (color of each chart coincides with color of the column header for the appropriate column);
- button “Удалить” (“Delete”) that allows to delete the selected history file;
- button “Отчет” (“Report”) that allows to form report of the “CONG-Prima” series device check in the system in the automated mode. Report will not be formed, if duration of the automated mode is less than 20 minutes (all table data are highlighted in yellow). Data about the system and the checked device, a table of dew point values reproduced by the system, appropriate mean values of dew points measured by the “CONG-Prima” series device, mean and maximum measurement errors of the “CONG-Prima” series device, and graph of the average measurement error of the “CONG-Prima” series device as well, are included into the report. Report can be saved in the separate file pressing button , and then viewed or printed with the aid of program “Pview.exe”;

Note: Last three digits of the system serial number are shown in the report of the calibrated system data.

- button “Экспорт” (“Export”) that allows to transfer digital data of the selected history file to the program for electronic table treatment “Microsoft Excel”. After pushing this button, launch of the “Excel” program will start (if it is installed to your computer) and data of the history file will be recorded to the table of this program. The further treatment of data shall be made by means of “Excel” program.

2.4.7 Выход “Список приборов “КОНГ-Прима”” (“List of “CONG-Prima devices”)

This box can be activated with the key-button “Регистрация приборов «КОНГ-Прима»” (“Registration of “CONG-Prima devices”) on the control panel and allows to add or delete devices in the list of “КОНГ-Прима №” (“CONG-Prima no”) series field on the control panel. Information of this list is used at formation of the report of “CONG-Prima” series devices’ check on the system in the automated mode. The box contains a table with the list of all registered devices, the panel for entering registration data and the following buttons for editing:

	To pass to the beginning of the list
	To pass into one line up;
	To pass into one line down;
	To pass to the end of the list;
	To add device;
	To delete device;
	To save changes in the line;
	To cancel changes in the line.

For registration of a new device press button “Добавить прибор” (“To add device”) and enter the device number directly into the list or input panel located under it. You must confirm the end of information input by pressing the edit button “Сохранить изменения в строке” (“To save changes in the line”).

To delete device you should select the line with the device appropriate number and press button “Удалить прибор” (“To delete the device”). In so doing all history files, referred to this device, will be deleted.

Note: For devices of “CONG-Prima” series with the switched on mode of digital transfer, registration will be done automatically.

3 The System operation

3.1 General

3.1.1 When you receive the system, please, assure in the packing integrity. If there is damage, you need to make the act.

3.1.2 In winter the transport packing shall be opened in the heated premises min 2 hours after bringing it there.

3.1.3 Check completeness in accordance with the shipping documentation.

3.1.4 Perform external examination of the thermohygrostate and computer state. In doing so, please, check integrity of the thermohygrostate case and availability of the earthing components.

3.1.5 When you receive the system, you should found the logbook for recording operating time and failures in accordance with appendix B.

3.2 Safety requirements

3.2.1 When you operate the system, you should guide by the following documents:

- «Electrical Installation Codes», 2003, ed.7;
- «Interindustry job safety rules (security rules) for operating electrical equipment» Job Safety Rules OM-016-2001;
- «Rules for operation of customers’ electrical installations», 2003.

3.2.2 By way of human protection from electric shock the system refers to class 01 by GOST 12.2.007.0-75.

3.2.3 While operating the system, the thermohygrostate case shall be earthed with the aid of its earth clamp. Instead of this the ground line may be used in the supplied cable, if power main sockets are connected to earth.

3.2.4 Technical maintenance and repair of the system shall be performed only after service disconnection.

3.2.5 Fire safety of the system by GOST 12.1.004-91 shall be provided by constructively built-in protective caps.

3.2.6 In accordance with GOST 12.1.005-88 requirements, the system does not emit hazardous substances into the working area air (generated settings of the workshop area microclimate beyond the limits established by sanitary regulations SanPiN2.2.4.548-96).

3.2.7 Protection degree for system IP21 by GOST14254-15 (against environmental impact); if the thermohygrostate case is earthed, its operating controls do not present any electrical danger for operator.

3.3 Preparing the system for operation

To assemble the case in accordance with the scheme of connections (see figure 4). In so doing you need to earth the thermohygrostate case. For doing this you should connect outlet of cut-set 2,5 mm² from the earthing bar to the earthing clamp on the device case. Resistance of the ground line shall not exceed 4 Om. In case of switching the power cord onto the three wire D.C. system with the earthing bar, it is assumed not to earth the thermohygrostate case.

3.4 Work with the system

3.4.1 To take a technological cap off the thermohygrostate standard chamber flange;

3.4.2 To switch on the computer and launch the operation program in accordance with item 2.3.;

3.4.3 To supply power to the thermohygrostate;

3.4.4 To perform preparation of the system and device of “CONG-Prima” series for calibration (verification) in accordance with appendix A.

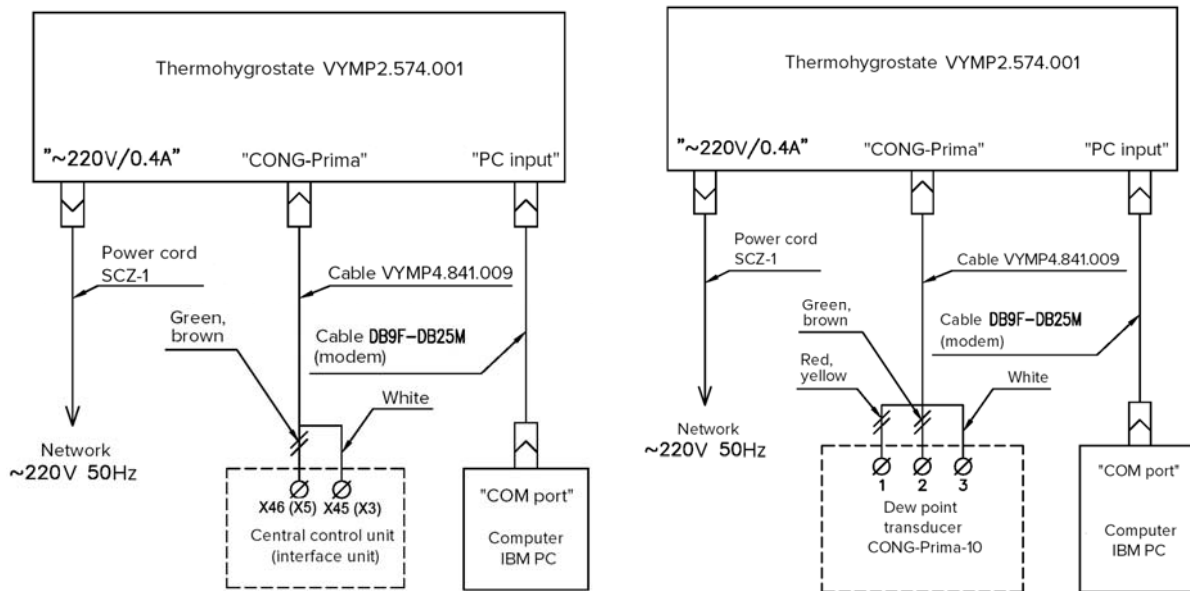

Figure 4 – Scheme of the system connections for “CONG-Prima” series DPT calibration

3.4.5 To perform calibration of the system current input according to item 2.4.5 for current output 4...20 mA of the calibrated device of “CONG-Prima” series. Current 4...20 mA in the output of transducer shall be set in accordance with its operational documentation.

3.4.6 Calibration and verification of “CONG-Prima” series devices shall be performed in accordance with its operational documentation.

3.4.7 Management by modes of the system operation shall be performed in accordance with item 2.4 of this manual.

3.4.8 On the computer monitor the following values are displayed:

- Value of the dew point reproduced by the system;
- Value of the dew point, measured by device under verification of “CONG-Prima” series;
- Deviation of value measured by device of “CONG-Prima” series from the one reproduced by the system.

3.4.9 Switching off the system

- To power off the thermohygrostate;
- To power off the computer;
- To remove the calibrated dew point transducer from the thermohygrostate standard chamber flange turning off the attachment bolts;
- To wait for moisture evaporation from the standard chamber mirror;
- To set technological cover onto the flange of the thermohygrostate standard chamber.

4 Technical maintenance

4.1 General

Under technical maintenance the actions providing control for the technical state of the system, maintenance works, failure control and overhaul-period renewal, are meant.

Technical manager of the operating enterprise is responsible for technical maintenance.

The person responsible for the system's operation shall be appointed before starting operation by administrative order.

Metrological characteristics of the system in the course of calibration interval correspond to set standards if consumer observes storage, transportation and operation regulations, stated in this operational manual.

In the course of maintenance performance all works, determined in the list of maintenance operations (Table 3), shall be done.

Table 3

Name of operation	Periodicity			Note
	Daily	Monthly	Yearly	
External operation	+	+	+	See item 4.2
Calibration	–	–	+	See item 4.3

4.2 Performance of external examination

During performance of the external examination the following shall be checked:

- absence of mechanical damage of the thermohygrostate case and connecting cables;
- availability of the earthing;
- availability of caps on the thermohygrostate standard chamber valve seats;
- absence of contamination on the surface of the thermohygrostate standard chamber condensation mirror.

Contamination of the surface of the thermohygrostate standard chamber condensation mirror shall be checked visually. The surface shall be glossy, streak-free, and free from dust. Otherwise, the surface shall be wiped with soft fabric, moistened in ethyl alcohol, and dried within 10 minutes.

4.3 The system calibration

The system calibration shall be performed according to verification procedure VYMP2.891.001 VP.

At the calibration performance, for measurement of the thermohygrostate condensation mirror temperature, one should assemble the technological device given in figure 5.

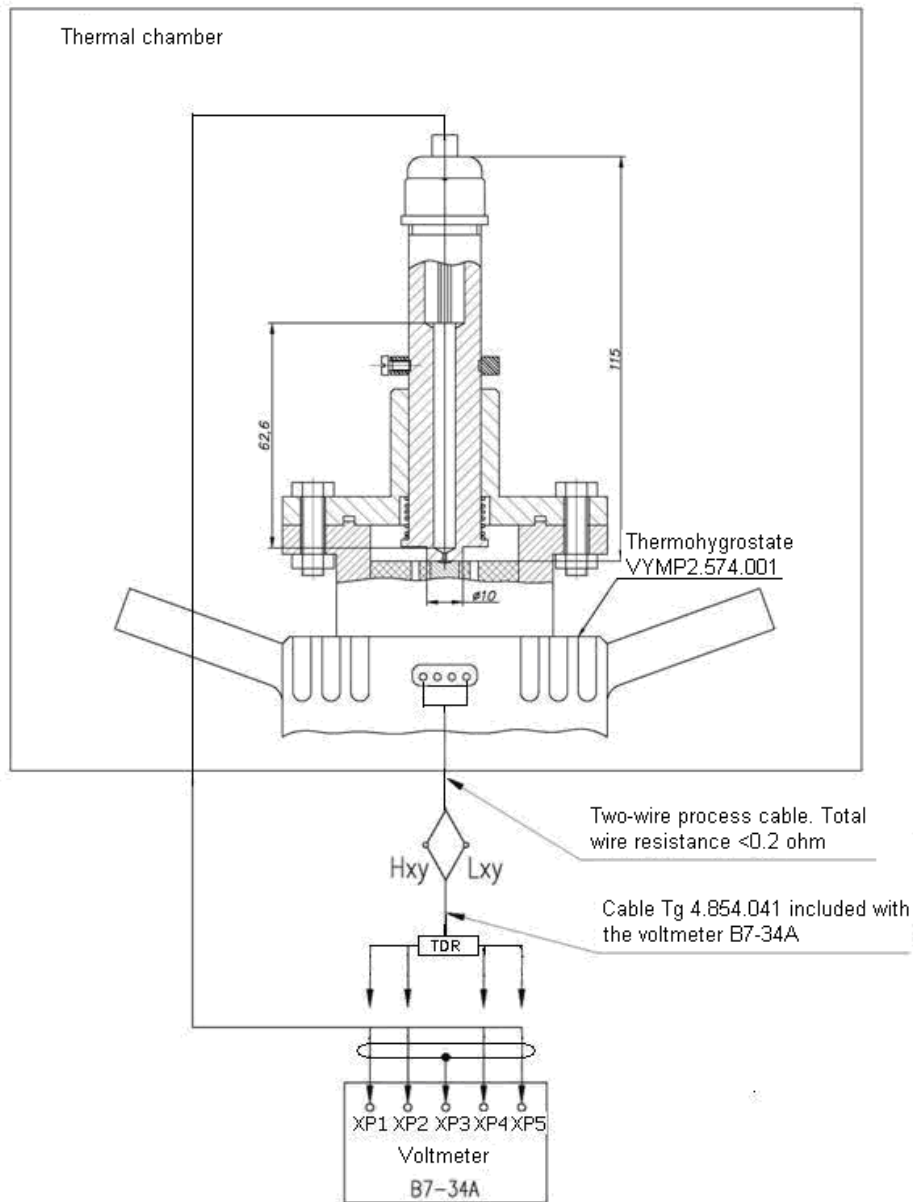

Figure 5 – Technological device for the system calibration

5 The current overhaul of the system

5.1 General

5.1.1 Repair works connected with opening of seals shall be performed only by manufacturing company or any specially authorized organization.

5.1.2 Repair works not connected with opening the seals, shall be performed by the company operational services according to current Safety regulations, Regulations for technical maintenance of consumers' electrical installations, and Job safety rules OM-016.

5.2 List of possible faults of the system

Possible faults of the system and ways for their removal are given in Table 4:
Table 4

Fault	Possible reason	Way for removal
System transfers to mode «Calibration»	There are no cross braces between terminals 1, 2 and 3, 4 of the thermohygrostate terminal block (for example, after calibration performance)	Establish cross braces between terminals 1, 2 and 3, 4 of the thermohygrostate terminal block (enumeration of terminals is from the left to the right)
The same	There is a lack of the computer hardware resource for the terminal program	Close all applications not related to the calibration system software program
Message appears: "Сбой при чтении параметров комплекса" ("Failure while reading the system settings")	Communication error	Switch off power supply of thermohygrostate for a few seconds and restart the program
The preset dew point is nor reproduced	The system is in the mode «Calibration»	Switch off the thermohygrostate power supply for a few seconds
The calibration system supports the set temperature, but indications of "CONG-Prima" device mounted on it gradually decrease (if dew points have been set higher than in the premises)	Lack of moisture on the mirror of the thermohygrostate standard chamber	Ensure that caps on valve seats of the thermohygrostate standard chamber are tightly closed. Remove "CONG-Prima" device off the thermohygrostate standard chamber flange, set the dew point minus 20 °C and wait for formation of frost deposit on the standard chamber mirror. Then install "CONG-Prima" device on the thermohygrostate and set the required dew point.
Indications of the dew point on the "CONG-Prima" device indicator and on control panel by calibration system do not coincide.	Calibration of the system current input has not been performed.	Perform calibration of the system current input in accordance with item 2.4.5.
The same	Working range of the system does not correspond to the current output range 4...20 mA of the calibrated device "CONG-Prima".	Change the working range of the system and perform calibration of the system current input in accordance with item 2.4.5.

Continuation of Table 3

Fault	Possible reason	Way for removal
Device “CONG-Prima” slowly goes out to the set dew point	Calibration mode is switched off in the device “CONG-Prima”	Switch on calibration mode in the device “CONG-Prima”. Note: at power supply to the device “CONG-Prima” calibration mode is always switched off.
In the status bar on the system’s control panel the message “No pilot signal” appears.	Calibration mode in the device “CONG-Prima” is switched off.	Switch on calibration mode in the device “CONG-Prima”. Note: at power supply to the device “CONG-Prima” calibration mode is always switched off.

If there are other malfunctions, please, consult the manufacturing company, and the system shall be taken out of service and delivered for overhaul performance.

6 Storage

6.1 The packed systems shall be stored in the consignor and consignee's warehouses, providing their conservation from mechanical damage, contamination and impact of aggressive environment, in storage conditions 3 by GOST 15150-69.

Storage of systems in shipping containers is allowed up to 6 months. On storage more than 6 months, devices shall be free from shipping containers and stored in storage conditions 1 by GOST 15150-69. General requirements to the system storage in the heated premises shall correspond to GOST P 52931-2008.

7 Transportation

7.1 General requirements for transportation

General requirements to systems' transportation shall correspond to GOST P 52931-2008.

7.2 Transportation terms

The packed devices shall be transported in closed vehicles by all transport types, including air types, in heated pressurized compartments, in accordance with valid regulations for cargo transportation on each transport type.

Terms for transportation concerning impact of climatic factors shall correspond to group of terms 5 (OJ4) by GOST 15150-69 for covered vehicles.

Terms for transportation concerning mechanical affects shall correspond to group F3 by GOST P 52931-2008.

8 Utilization

8.1 Materials and completing items used at manufacture of "CONG" systems both while exploiting for its term of service and on the resource expiry as well, are not dangerous for human health, manufacturing and warehouse premises, and environment. Utilization of unserviceable "CONG" systems can be made by any way accessible for the customer.

Appendix A (mandatory)

Methodology for system preparation to calibration of “CONG-Prima” series devices

A.1 Calibration system “CONG” is destined for calibration and graduation of “CONG-Prima” measurement facilities for dew points, operating by principle of the cooled mirror. Operation of such type of hygrometers assumes the intermediate measurement of the dew point temperature.

At cooling the mirror, in the field of negative temperature the phase transfer “water-ice” takes place. Temperature of the phase transfer depends on several factors: degree of the condensation mirror purity, speed of cooling, sensor sensitivity, etc. As practice shows, for hygrometers of “CONG-Prima” series temperature of phase transfer depending of above-mentioned factors lies within the range from minus 15 to minus 30°C, i.e. within the range of dew point measurement. Instability of this temperature leads to instable measurements of dew point in the field of temperatures below minus 15 °C, since the dew point can be measured by water or ice (frost) at the same preset temperature on the calibration system “CONG”.

A.2 To exclude “ambiguity” of measurements it is necessary to shift temperature of the phase transfer below the range of hygrometer measurements by adding alcoholic fumes to the thermohygrostate measurement chamber in accordance with methodology given below.

A.2.1 After power supply to the thermohygrostate, you should set the dew point value +10 °C in accordance with item 2.4.3 of this manual.

A.2.2 Use cotton buds moistened in spirit (ethyl, isopropyl) to shake off excesses and wipe the thermohygrostate mirror.

A.2.3 Set a dew point value minus 30 °C and wait for formation of the frost layer on the thermohygrostate mirror (visually controlled).

A.2.4 Set the dew point transducer onto the flange of the thermohygrostate standard chamber and fix at least with two bolts. Check availability of caps on valve seats of the thermohygrostate standard chamber.

ATTENTION!

IT IS FORBIDDEN to set the dew point transducer on the thermohygrostate standard chamber flange if there is no fluoroplastic sealing ring on the sensor case of the dew point transducer primary sensor, since this can lead to the thermohygrostate break.

Be results of tests the following recommendations can be formulated for calibration of analyzers “CONG-Prima 10” to the calibration system “CONG”: before analyzer is installed on the calibration system “CONG”, you need to set temperature +10,0°C on the calibration system CONG mirror. Wipe the cotton bud in spirit, shake off excesses, and grease the condensation mirror of calibration system CONG. Then set temperature minus 30,0 °C on the calibration system CONG. After that, install DPT on the calibration system CONG.

Appendix B
(recommended)

Logbook for operating files, faults and failures

Name and designation (of the article)		Calibration system «CONG» VYMP2.891.001					
Manufacturing company		LLC “SPF “Vympel”, Saratov					
Serial number							
Date of issue							
Company-consumer							
Date of starting operation							
Terms for operation							
Settings of operating mode							
A person responsible for registration, damage, failure							
Date, shift	Failure period, hour	External manifestation of failure and its reason	Way for removal of faults, failure	Recovery time, hour	Additional data of failure, the failed assembly unit (part)	Signature of persons registered damage, failure and removed failure	Note