

# COMPRESSED AIR FILTERS



*Atlas Copco*





## ***COMMITTED TO SUPERIOR PRODUCTIVITY***

### **In-house development & testing**

Since 1998, our dedicated filtration team is responsible for in-house development of cutting-edge filtration solutions. This results in expert know-how of filtration mechanisms, state-of-the-art test facilities and breakthrough innovations. For many years, our filtration team has cooperated closely with the University of Karlsruhe, a leading institute in research of filtration mechanisms.

### **Rigorous quality control**

To ensure the highest standards, all Atlas Copco products are subjected to rigorous quality control testing. The entire filter range is produced in-house, on the most advanced production lines, using the most stringent methods in the industry. You can rest assured at all times that strict certification and testing procedures are conducted to ensure our filtration products meet the highest standards.

# THE ATLAS COPCO SOLUTION

Compressed air can be contaminated by dirt, water and oil, which can be further divided as follows:

- **DIRT:** micro-organisms, dust, solid particles, rust particles.
- **WATER:** water vapor, condensed liquid water, water aerosols, acidic condensates.
- **OIL:** liquid oil, oil aerosol, hydrocarbon vapor.

Atlas Copco offers a wide selection of filtration solutions and application knowledge. Different product types and grades are available to meet your every demand. Only genuine spare cartridges guarantee the Atlas Copco filter performance.



## Flanged design

6 grades  
12 sizes  
550 → 8,000 l/s  
1,200 → 17,000 cfm

## Tower design

1 grade  
9 sizes  
20 → 310 l/s  
42 → 657 cfm

20 bar / 290 psi  
50 bar / 725 psi  
100 bar / 1,450 psi  
350 bar / 5,075 psi

## Threaded design

5 grades  
9 sizes  
15 → 944 l/s  
32 → 2,000 cfm

## Threaded design

5 grades  
11 sizes  
9 → 520 l/s  
19 → 1,102 cfm

## Threaded design

1 grade  
10 sizes  
400 → 6,700 l/min  
14 → 237 cfm



## Threaded design

6 grades  
11 sizes  
9 → 550 l/s  
19 → 1,200 cfm

Name	DDp+	PDp+	DD+	PD+	UD+	QD+	QDT	H High pressure		SFA Silicone-free		MV Medical vacuum		
	DDp	PDp	DD	PD		QD								
Grade	Rough	Fine	Rough	Fine	Ultimate	Basic	Optimal	Rough & Fine	Rough & Fine	Basic	Rough & Fine	Rough & Fine	Basic	Fine
Contaminant	Dry dust		Oil aerosol / wet dust			Oil vapor		Rough & Fine	Rough & Fine	Basic	Rough & Fine	Rough & Fine	Basic	Dry dust
General applications								Special applications						



Dry dust



Micro-organisms



Oil aerosol



Wet dust



Oil vapor



Water drops

# CERTIFIED PERFORMANCE

Atlas Copco filters are qualified according to the ISO 8573-1:2010 standard. This is the latest edition of the standard. Beware of filters that comply with earlier editions, such as ISO 8573-1:1991 or ISO 8573-1:2001. The difference is inferior quality of the delivered compressed air. This qualification is a result of our filters being tested according to ISO 12500-1:2007, ISO 12500-2:2007, and ISO 12500-3:2009. These specify the test layout, test procedures and inlet conditions required for testing coalescing filters, vapor filters, and solid particle filters used in compressed air systems, to determine their effectiveness in removing oil aerosol, oil vapor and solid particles. The measurements of the air purity downstream the filter for each specific contaminant have been performed according to the test methods described in respectively ISO 8573-2:2007, ISO 8573-5:2001 and ISO 8573-4:2001. Tests have been conducted in-house as well as in external labs, and are independently validated by TÜV.

## ISO certification

Atlas Copco's filters have been fully tested and qualified according to the following ISO standards:

- ISO 8573-1:2010: Compressed air - Contaminants and purity classes
- ISO 8573-2:2007: Compressed air - Test method for oil aerosol content
- ISO 8573-4:2001: Compressed air - Test method for dust
- ISO 8573-5: 2001: Compressed air - Test method for oil vapor and organic solvent content
- ISO 12500-1:2007: Filters for compressed air - test methods - oil aerosols
- ISO 12500-2:2007: Filters for compressed air - test methods - oil vapors
- ISO 12500-3:2009: Filters for compressed air - test methods - particulates



## Certified peace of mind

<b>FILTER APPROVALS</b>	<b>COMPANY CERTIFICATION</b>
CE ASME CRN	® ® ®
<b>ACTIVE MEMBER OF</b>	
pneurop CAGI bcas VDMA	

# A SOLUTION FOR EVERY APPLICATION

At different points of use, different compressed air purities might be needed, depending on the application. The various air purity classes are provided in the table below, which clearly shows the various Atlas Copco filters and dryers that meet all the different classes.

ISO 8573-1:2010 CLASS	Solid particles		Water	Oil (= aerosol, liquid, vapor)
	Wet conditions	Dry conditions		
0	As specified by the customer*			Oil-free compressor
1	DD+ & PD+	DDp+ & PDp+	Desiccant dryer	DD+ & PD+ & QD+/QDT
	UD+			UD+ & QD+/QDT
2	DD+	DDp+	Desiccant dryer	DD+ & PD+ UD+
3	DD+	DDp+	Desiccant dryer, membrane dryer, rotary drum dryer	DD+
4	DD+	DDp+	Membrane dryer, refrigerant dryer	DD+
5	DD+	DDp+	Membrane dryer, refrigerant dryer	-
6	-	-	Membrane dryer, refrigerant dryer	-

\* Please contact your Atlas Copco sales representative.

## Examples of typical installations

<b>A</b>	Compressor - UD+	Air purity class ISO 8573-1:2010 [1:-:2]
<b>B</b>	Compressor - UD+ - Refrigerant dryer	Air purity class ISO 8573-1:2010 [1:4:2]*
<b>C</b>	Compressor - UD+ - Refrigerant dryer - QDT - DDp+	Air purity class ISO 8573-1:2010 [2:4:1]
<b>D</b>	Compressor - UD+ - Desiccant dryer - DDp+	Air purity class ISO 8573-1:2010 [2:2:2]
<b>E</b>	Compressor - UD+ - Desiccant dryer - QDT - DDp+ - PDp+	Air purity class ISO 8573-1:2010 [1:2:1]

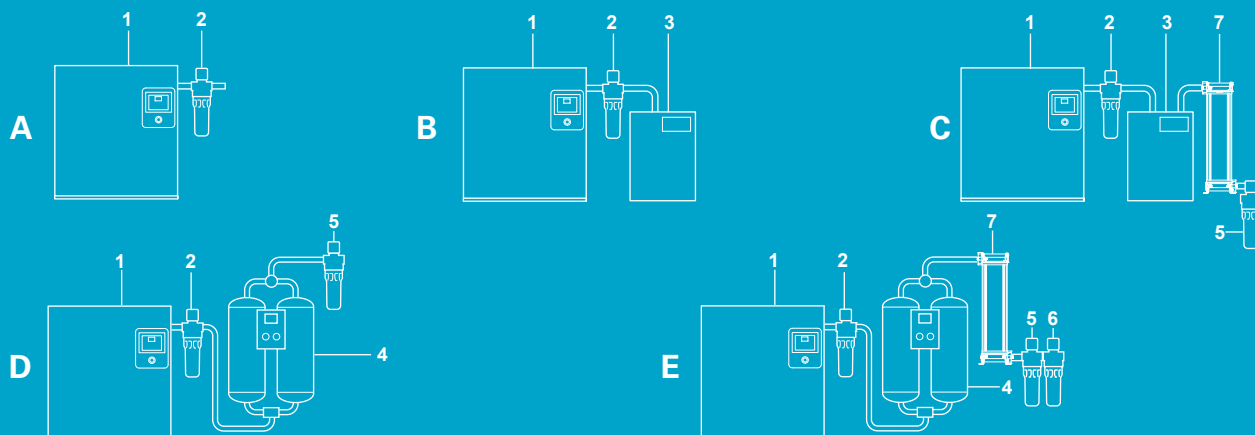

1. Compressor  
2. UD+ filter

3. Refrigerant dryer  
4. Desiccant dryer

5. DDp+ filter  
6. PDp+ filter

7. QDT filter

\* Particle class 1 is reached directly after UD+. As downstream piping & vessels can add particles, it is advised to install particle filters DDp+ and PDp+ just before the application to reach particle class 1 at point of use.

The compressor should be equipped with a liquid water separation system such as an after cooler including a drain or a water separator (WSD). Always install a water separator in front of a coalescence filter. In case of critical applications, install extra air treatment products at point of use for the removal of pipeline contamination and condensation.

# UD+ SERIES

## Two-in-one oil coalescing filters with supreme energy savings

UD+ filters efficiently reduce oil aerosol, wet dust and water drops in your compressed air stream to protect your investment, equipment and processes. The UD+ combines two filtration steps (DD+ and PD+) into one, a unique technology to meet the high-quality requirements of diverse applications and provide ultimate energy savings.



## YOUR BENEFITS

### 40% energy savings

A 40% lower pressure drop than the conventional filter combination results in 40% higher energy efficiency.

### Pure air

Air purity is equal to that obtained using two filters in line, thanks to the thick filter package of UD+ filters.

### Save space

The two-in-one filtration concept reduces installation space and complexity, making UD+ filters particularly suitable for applications where space is at a premium.

### Save money

Install UD+ filters to enjoy significant cost savings compared to conventional filters.

## Performance

	UD+
Contaminant	Oil aerosol/wet dust
Test method	ISO 8573-2:2007, ISO 12500-1:2007
Maximum oil carry-over (mg/m <sup>3</sup> )*	0.0009
Wet pressure drop (mbar)	245
Element service	After 4,000 operating hours or 1 year
Precede with	Water separation

\* Inlet oil concentration = 10 mg/m<sup>3</sup>. Oil = oil aerosol and liquid.

## Sizing & dimensions

FILTER SIZE UD+	Nominal capacity		Reference pressure		Maximum pressure		Connections	Dimensions						Free space for cartridge replacement		Weight	
	l/s	cfm	bar(e)	psig	bar(e)	psig		A		B		C		D		kg	lbs
								mm	in	mm	in	mm	in	mm	in		
9+	9	19	7	102	16	232	3/8	90	3.5	61	2.4	268	10.6	75	2.9	1.0	2.2
15+	15	32	7	102	16	232	1/2	90	3.5	61	2.4	268	10.6	75	2.9	1.1	2.4
25+	25	53	7	102	16	232	1/2	90	3.5	61	2.4	323	12.8	75	2.9	1.3	2.9
45+	45	95	7	102	16	232	3/4 & 1	110	4.3	99	3.9	374	14.7	75	2.9	1.6	4.2
60+	60	127	7	102	16	232	1	110	4.3	99	3.9	414	16.3	75	2.9	2.1	4.6
100+	100	212	7	102	16	232	1	140	5.5	105	4.0	425	16.7	100	3.9	3.7	8.2
140+	140	297	7	102	16	232	1-1/2	140	5.5	105	4.1	520	20.5	100	3.9	4.2	9.3
180+	180	381	7	102	16	232	1-1/2	140	5.5	105	4.1	603	23.7	100	3.9	4.5	9.9
220+	220	466	7	102	16	232	1-1/2	140	5.5	105	4.1	603	23.7	100	3.9	4.6	10.1
310+	310	657	7	102	16	232	2 & 2-1/2	179	7.1	121	4.8	689	27.1	150	5.9	6.9	15.2
425+	425	901	7	102	16	232	3	210	8.3	128	5.1	791	31.1	200	7.9	11.0	24.2
550+	550	1165	7	102	16	232	3	210	8.3	128	5.1	961	37.8	200	7.9	12.6	27.8
550+F	550	1165	7	102	16	232	DN80	370	14.6	280	11.0	1295	51.0	1375	54.1	76.0	167.6
850+F	850	1801	7	102	16	232	DN100	510	20.1	410	16.1	1360	53.5	1500	59.1	141.0	310.9
1100+F	1100	2331	7	102	16	232	DN100	510	20.1	410	16.1	1360	53.5	1500	59.1	143.0	315.3
1400+F	1400	2967	7	102	16	232	DN150	620	24.4	485	19.1	1480	58.3	1560	61.4	210.0	463.0
1800+F	1800	3814	7	102	16	232	DN150	640	25.2	490	19.3	1555	61.2	1640	64.6	176.0	388.0
2200+F	2200	4662	7	102	16	232	DN150	640	25.2	490	19.3	1555	61.2	1640	64.6	178.0	392.4
3000+F	3000	6357	7	102	16	232	DN200	820	32.3	650	17.7	1745	68.7	1710	67.3	420.0	925.9
4000+F	4000	8476	7	102	16	232	DN200	820	32.3	650	17.7	1745	68.7	1710	67.3	428.0	943.6
5000+F	5000	10595	7	102	16	232	DN200	820	32.3	650	17.7	1745	68.7	1710	67.3	432.0	952.4
6000+F	6000	12714	7	102	16	232	DN250	920	36.2	815	32.1	2085	82.1	1625	64.0	671.0	1479.3
7000+F	7000	14833	7	102	16	232	DN250	920	36.2	815	32.1	2085	82.1	1625	64.0	675.0	1488.1
8000+F	8000	16952	7	102	16	232	DN300	1040	40.9	930	36.6	2070	81.5	1625	64.0	900.0	1984.2

## Correction factors

Inlet pressure (bar)	1	2	3	4	5	6	7	8	10	12	14	16
Inlet pressure (psig)	15	29	44	58	72.5	87	102	116	145	174	203	232
Correction factor	0.38	0.53	0.65	0.75	0.83	0.92	1.00	1.06	1.20	1.31	1.41	1.50

### Example

- Working pressure 3 bar(g), compressed air flow 35 l/s.
- Multiply the nominal capacity of the selected filter with the corresponding correction factor at the required working pressure to obtain the capacity at working pressure:
  - Size 45+: 45 l/s \* 0.65 = 29 l/s => the 45+ filter size is not large enough.
  - Size 60+: 60 l/s \* 0.65 = 39 l/s => the 60+ filter size is the size to select.

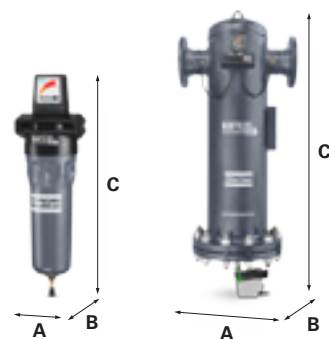

## Options

- Filter connection kit for easy mounting in series (9-550 l/s).
- Wall mounting kit simplifies installation (9-550 l/s).
- Quick coupling connects the filter with a drain or oil/water separator.
- Voltage-free contact mounted in the differential pressure gauge, to give remote indication of cartridge replacement.
- EWD electronic drain with no loss of compressed air and an alarm function (EWD is optional on sizes 9-550 l/s; standard on sizes ≥550F).

## Certification

- ISO 8573-2:2007
- ISO 12500-1:2007



Wall mounting kit

# DD(+)/PD(+) SERIES

## High performance oil coalescing filters

DD(+) and PD(+) filters efficiently reduce oil aerosol, wet dust and water drops in your compressed air stream. These could come from the lubrication of the compressor element, the intake air, and the compressor installation itself. These innovative filtration solutions are engineered to cost-effectively provide the best air purity and meet today's increasing quality demands.



## YOUR BENEFITS

### Maximum oil aerosol, wet dust and water droplet filtration and drainage

High-efficient glass fiber and foam media.

### Significant energy savings & limited system operating costs

Optimal design and filter media allow low pressure losses.

### High reliability

High-performance stainless steel cores, double O-rings, epoxy sealed caps, and anti-corrosive coated filter housing.

### Easy maintenance

External ribs on the threaded housing, or a rotating bottom cover for the welded housings, and push-on elements.

### Monitoring of energy use

Differential pressure indication (indicator for sizes 10-35 l/s, gauge for sizes 50-8000 l/s) (optional for standard range).

## Performance

	DD	PD	DD+	PD+
Contaminant	Oil aerosol/wet dust			
Test method	ISO 8573-2:2007, ISO 12500-1:2007			
Maximum oil carry-over (mg/m <sup>3</sup> )*	0.1*	0.01*	0.07*	0.008*
Wet pressure drop (mbar)	245	280	180	215
Element service	After 4,000 operating hours or 1 year			
Precede with	Water separation	Water separation DD	Water separation	Water separation DD+

\* Inlet oil concentration = 10 mg/m<sup>3</sup>. Oil = oil aerosol and liquid.

## Sizing & dimensions

FILTER SIZE DD/PD		Nominal capacity				Reference pressure		Maximum pressure		Connections	Dimensions						Free space for cartridge replacement		Weight	
		Standard		+							A		B		C		D			
Standard	+	l/s	cfm	l/s	cfm	bar(e)	psig	bar(e)	psig	in	mm	in	mm	in	mm	in	mm	in	kg	lbs
12	10+	12	25	10	21	7	102	20	290	3/8	90	3.5	61	2.4	268	10.6	75	2.9	1.0	2.2
25	20+	25	53	20	42	7	102	20	290	1/2	90	3.5	61	2.4	268	10.6	75	2.9	1.1	2.4
45	35+	45	95	35	74	7	102	20	290	1/2	90	3.5	61	2.4	323	12.7	75	2.9	1.3	2.9
65	50+	65	138	50	106	7	102	20	290	3/4 & 1	110	4.3	99	3.9	374	14.7	75	2.9	1.6	4.2
90	70+	90	191	70	148	7	102	20	290	1	110	4.3	99	3.9	414	16.3	75	2.9	2.1	4.6
160	130+	160	339	130	275	7	102	20	290	1-1/2	140	5.5	105	4.1	520	20.5	100	3.9	4.2	9.3
215	170+	215	456	170	360	7	102	20	290	1-1/2	140	5.5	105	4.1	603	23.7	100	3.9	4.5	9.9
265	210+	265	562	210	445	7	102	20	290	1-1/2	140	5.5	105	4.1	603	23.7	100	3.9	4.6	10.1
360	310+	360	763	310	657	7	102	20	290	2 & 2-1/2	179	7.0	121	4.8	689	27.1	150	5.9	6.9	15.2
525	425+	525	1112	425	901	7	102	16	232	3	210	8.3	128	5.0	791	31.1	200	7.9	11.0	24.2
690	550+	690	1462	550	1165	7	102	16	232	3	210	8.3	128	5.0	961	37.9	200	7.9	12.6	27.8
630F	550+F	630	1335	550	1165	7	102	16	232	DN80	370	14.6	190	7.5	1295	51.0	1375	54.1	76.0	167.6
970F	850+F	970	2055	850	1801	7	102	16	232	DN100	510	20.1	230	9.1	1360	53.5	1500	59.1	141.0	310.9
1260F	1100+F	1260	2670	1100	2331	7	102	16	232	DN100	510	20.1	230	9.1	1360	53.5	1500	59.1	143.0	415.3
1600F	1400+F	1600	3390	1400	2967	7	102	16	232	DN150	620	24.4	290	11.4	1480	58.3	1560	61.4	210.0	463.0
2200F	1800+F	2200	4662	1800	3814	7	102	16	232	DN150	640	25.2	285	11.2	1555	61.2	1640	64.6	176.0	388.0
2400F	2200+F	2400	5086	2200	4662	7	102	16	232	DN150	640	25.2	285	11.2	1555	61.2	1640	64.6	178.0	392.4
3600F	3000+F	3600	7628	3000	6357	7	102	16	232	DN200	820	32.3	400	15.7	1745	68.7	1710	67.3	420.0	925.9
-	4000+F	-	-	4000	8476	7	102	16	232	DN200	820	32.3	400	15.7	1745	68.7	1710	67.3	428.0	943.6
-	5000+F	-	-	5000	10595	7	102	16	232	DN250	820	32.3	400	15.7	1745	68.7	1710	67.3	432.0	952.4
-	6000+F	-	-	6000	12714	7	102	16	232	DN250	920	32.3	550	18.9	2085	80.3	1625	64	594.0	1034.0
-	7000+F	-	-	7000	14833	7	102	16	232	DN300	920	36.2	550	21.7	2085	82.1	1625	64	597.0	1479.3
-	8000+F	-	-	8000	16952	7	102	16	232	DN300	1040	40.9	525	20.7	2070	81.5	1625	64	1140.0	1984.2

## Correction factors

Inlet pressure (bar)	1	2	3	4	5	6	7	8	10	12	14	16
Inlet pressure (psig)	15	29	44	58	72.5	87	102	116	145	174	203	232
Correction factor	0.38	0.53	0.65	0.75	0.83	0.92	1.00	1.06	1.20	1.31	1.41	1.50

### Example

- Working pressure 3 bar(g), compressed air flow 35 l/s.
- Multiply the nominal capacity of the selected filter with the corresponding correction factor at the required working pressure to obtain the capacity at working pressure:
  - Size 50+: 50 l/s \* 0.65 = 33 l/s => the 50+ filter size is not large enough.
  - Size 70+: 70 l/s \* 0.65 = 46 l/s => the 70+ filter size is the size to select.

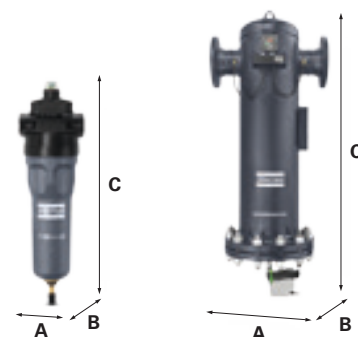

## Options

- Filter connection kit for easy mounting in series (10+ - 550+ l/s and 12-690 l/s).
- Wall-mounting kit simplifies installation (10+ - 550+ l/s and 12-690 l/s).
- Quick coupling connects the filter with a drain or oil/water separator.
- Voltage-free contact mounted in the differential pressure gauge, to give remote indication of cartridge replacement.
- EWD electronic drain with no loss of compressed air and an alarm function (EWD is optional on sizes 10+ - 550+ l/s and 12-690 l/s; standard on sizes ≥550F).

## Certification

- ISO 8573-2:2007
- ISO 12500-1:2007



EWD electronic drain

# DDp(+)/PDp(+) SERIES

## Optimal dry dust filtration

DDp(+) and PDp(+) filters efficiently prevent dust, particulates and micro-organisms arising from corrosion, dirt and adsorption material from entering your compressed air stream. These innovative filtration solutions are engineered to cost-effectively provide the best air purity and meet today's increasing quality demands.



## YOUR BENEFITS

### Maximum dirt, solid particles, micro-organisms and rust particles removal

High-efficient glass fiber and foam media.

### Significant energy savings & limited system operating costs

Optimal design and filter media allow for low pressure losses.

### High reliability

High-performance stainless steel cores, double O-rings, epoxy sealed caps, and anti-corrosive coated filter housing.

### Easy maintenance

External ribs on the threaded housing, or a rotating bottom cover for the welded housings, and push-on elements.

### Monitoring of energy use

Differential pressure indication (indicator for sizes 10-35 l/s, gauge for sizes 45-8000 l/s) (optional for standard range).

## Performance

	DDp	PDp	DDp+	PDp+
Contaminant	Dry dust			
Test method	ISO 8573-4:2001, ISO 12500-3:2009			
Particle removal efficiency (% at MPPS)	99.81	99.97	99.92	99.98
Dry pressure drop (mbar)	135	150	85	100
Element service	After 4,000 operating hours or 1 year or 350 mbar pressure drop			
Precede with	Dryer	Dryer DDp	Dryer	Dryer DDp+

## Sizing & dimensions

FILTER SIZE DD/PD		Nominal capacity				Reference pressure		Maximum pressure		Connections	Dimensions						Free space for cartridge replacement		Weight	
		Standard		+							A		B		C		D			
Standard	+	l/s	cfm	l/s	cfm	bar(e)	psig	bar(e)	psig	in	mm	in	mm	in	mm	in	mm	in	kg	lbs
12	10+	12	25	10	21	7	102	20	290	3/8	90	3.5	61	2.4	268	10.6	75	2.9	1.0	2.2
25	20+	25	53	20	42	7	102	20	290	1/2	90	3.5	61	2.4	268	10.6	75	2.9	1.1	2.4
45	35+	45	95	35	74	7	102	20	290	1/2	90	3.5	61	2.4	323	12.7	75	2.9	1.3	2.9
65	50+	65	138	50	106	7	102	20	290	3/4 & 1	110	4.3	99	3.9	374	14.7	75	2.9	1.6	4.2
90	70+	90	191	70	148	7	102	20	290	1	110	4.3	99	3.9	414	16.3	75	2.9	2.1	4.6
160	130+	160	339	130	275	7	102	20	290	1-1/2	140	5.5	105	4.1	520	20.5	100	3.9	4.2	9.3
215	170+	215	456	170	360	7	102	20	290	1-1/2	140	5.5	105	4.1	603	23.7	100	3.9	4.5	9.9
265	210+	265	562	210	445	7	102	20	290	1-1/2	140	5.5	105	4.1	603	23.7	100	3.9	4.6	10.1
360	310+	360	763	310	657	7	102	20	290	2 & 2-1/2	179	7.0	121	4.8	689	27.1	150	5.9	6.9	15.2
525	425+	525	1112	425	901	7	102	16	232	3	210	8.3	128	5.0	791	31.1	200	7.9	11.0	24.2
690	550+	690	1462	550	1165	7	102	16	232	3	210	8.3	128	5.0	961	37.9	200	7.9	12.6	27.8
630F	550+F	630	1335	550	1165	7	102	16	232	DN80	370	14.6	190	7.5	1295	51.0	1375	54.1	76.0	167.6
970F	850+F	970	2055	850	1801	7	102	16	232	DN100	510	20.1	230	9.1	1360	53.5	1500	59.1	141.0	310.9
1260F	1100+F	1260	2670	1100	2331	7	102	16	232	DN100	510	20.1	230	9.1	1360	53.5	1500	59.1	143.0	415.3
1600F	1400+F	1600	3390	1400	2967	7	102	16	232	DN150	620	24.4	290	11.4	1480	58.3	1560	61.4	210.0	463.0
2200F	1800+F	2200	4662	1800	3814	7	102	16	232	DN150	640	25.2	285	11.2	1555	61.2	1640	64.6	176.0	388.0
2400F	2200+F	2400	5086	2200	4662	7	102	16	232	DN150	640	25.2	285	11.2	1555	61.2	1640	64.6	178.0	392.4
3600F	3000+F	3600	7628	3000	6357	7	102	16	232	DN200	820	32.3	400	15.7	1745	68.7	1710	67.3	420.0	925.9
-	4000+F	-	-	4000	8476	7	102	16	232	DN200	820	32.3	400	15.7	1745	68.7	1710	67.3	428.0	943.6
-	5000+F	-	-	5000	10595	7	102	16	232	DN250	820	32.3	400	15.7	1745	68.7	1710	67.3	432.0	952.4
-	6000+F	-	-	6000	12714	7	102	16	232	DN250	920	32.3	550	18.9	2085	80.3	1625	64	594.0	1034.0
-	7000+F	-	-	7000	14833	7	102	16	232	DN300	920	36.2	550	21.7	2085	82.1	1625	64	597.0	1479.3
-	8000+F	-	-	8000	16952	7	102	16	232	DN300	1040	40.9	525	20.7	2070	81.5	1625	64	1140.0	1984.2

## Correction factors

Inlet pressure (bar)	1	2	3	4	5	6	7	8	10	12	14	16
Inlet pressure (psig)	15	29	44	58	72.5	87	102	116	145	174	203	232
Correction factor	0.38	0.53	0.65	0.75	0.83	0.92	1.00	1.06	1.20	1.31	1.41	1.50

### Example

- Working pressure 3 bar(g), compressed air flow 35 l/s.
- Multiply the nominal capacity of the selected filter with the corresponding correction factor at the required working pressure to obtain the capacity at working pressure:
  - Size 50+: 50 l/s \* 0.65 = 33 l/s => the 50+ filter size is not large enough.
  - Size 70+: 70 l/s \* 0.65 = 46 l/s => the 70+ filter size is the size to select.

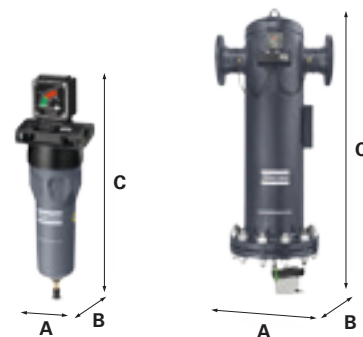

## Options

- Filter connection kit for easy mounting in series (10+ - 550+ l/s and 12-690 l/s).
- Wall-mounting kit simplifies installation (10+ - 550+ l/s and 12-690 l/s).
- Voltage-free contact mounted in the differential pressure gauge, to give remote indication of cartridge replacement.

## Certification

- ISO 8573-4:2001
- ISO 12500-3:2009

Voltage-free contact



# QDT SERIES

## Activated carbon towers for optimal oil vapor filtration

The high efficiency activated carbon tower is capable of removing hydrocarbons, odors and oil vapor from compressed air.

The activated carbon layers will, by the use of adsorption, reduce the residual oil content to lower than 0.003 mg/m<sup>3</sup>.

The pressure drop is low and stays minimal during the filter's lifetime.



## YOUR BENEFITS

### Maximum oil vapor removal

Superb activated carbon material.

### Low pressure drop

Optimal internal flow path.

### High reliability

Robust design and optimal filter material.

### Options

- Oil indicator ensures pure air.
- Wall mounting kit for easy installation (20 – 185 l/s).



### Certification

ISO 8573-5:2001

## Performance

	QDT
Contaminant	Oil vapor
Test method	ISO 8573-5:2001, ISO 12500-2:2007
Maximum oil carry-over (mg/m <sup>3</sup> )*	0.003
Dry pressure drop (mbar)	125
Element service	After 4,000 operating hours or 1 year
Precede with	Water separation UD+ or DD+/PD+ Dryer

\* After UD+ or DD+/PD+ with inlet oil concentration of 10 mg/m<sup>3</sup>.

## Sizing & dimensions

FILTER SIZE QDT	Nominal capacity		Connections G or NPT	Dimensions						Weight	
				A		B		C			
	l/s	cfm	in	mm	in	mm	in	mm	in	kg	lbs
20	20	42	1/2	490	19	223	9	190	7	10	22
45	45	95	1	715	28	223	9	190	7	15	33
60	60	127	1	840	33	223	9	190	7	18	40
95	95	210	1	715	28	387	15	190	7	29	64
125	125	265	1 1/2	840	33	387	15	190	7	34	75
150	150	318	1 1/2	715	28	551	22	190	7	42	93
195	185	392	1 1/2	840	33	551	22	190	7	50	110
245	245	519	1 1/2	840	33	715	28	190	7	67	148
310	310	657	1 1/2	840	33	879	35	190	7	84	185

## Correction factors

For other compressed air inlet temperatures, please multiply the filter capacity by the following correction factor (Kt):

Inlet temperature °C	20	25	30	35	40	45	50	55	60
Inlet temperature °F	68	77	96	95	104	113	122	131	140
Correction factor	1.67	1.43	1.25	1	0.71	0.56	0.37	0.25	0.19

For other compressed air inlet pressures, please multiply the filter capacity by the following correction factor (Kp):

Inlet pressure bar	3	4	5	6	7	8	9	10	11	12	13
Inlet pressure psi	44	58	73	87	102	116	131	145	160	174	193
Correction factor	0.57	0.77	0.83	1	1	1	1	1.05	10.5	1.11	1.18

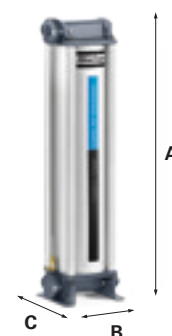

### Example

- Working temperature 50°C, pressure 12 bar(g), compressed air flow 100 l/s.
- Multiply the nominal capacity of the selected filter with the corresponding correction factors at the required working temperature and pressure to obtain the capacity at working pressure:
  - Size 150: 150 l/s \* 0.37 \* 1.11 = 62 l/s => the 125 filter size is not large enough.
  - Size 195: 195 l/s \* 0.37 \* 1.11 = 80 l/s => the 195 filter size is not large enough.
  - Size 245: 245 l/s \* 0.37 \* 1.11 = 101 l/s => the 245 filter size is the size to select.

## UD+ & QDT: the winning combination



UD+	QDT
Liquid oil & oil aerosol removal	Oil vapor removal
Guaranteed 0.0009 mg/m <sup>3</sup> aerosol and liquid	Guaranteed 0.003 mg/m <sup>3</sup> vapor
40% pressure drop reduction compared to DD+/PD+	65% pressure drop reduction compared to previous QDT
50% footprint reduction	Extremely compact compared to vessel designs

## CLASS 1: Total oil, according ISO 8573-1:2010

The Atlas Copco UD+ - QDT filter train meets the requirements of air purity class 1 for total oil, according to ISO 8573-1:2010, in a typical compressed air installation.



# QD(+) SERIES

## High performance oil vapor filters

QD(+) filters efficiently reduce hydrocarbons, odors and oil vapor in your compressed air stream to protect your investment, equipment and processes. The activated carbon layers will, by the use of adsorption, reduce the residual oil content to less than 0.003 mg/m<sup>3</sup>. The pressure drop is low and stays minimal during the lifetime of the filter.



## YOUR BENEFITS

### Maximum oil vapor removal

Highly efficient activated carbon layers.

### Significant energy savings & limited system operating costs

Low pressure losses.

### High reliability

High-performance stainless steel cores, double O-rings, epoxy sealed caps, and anti-corrosive coated filter housing.

### Easy maintenance

External ribs on the threaded housing, or a rotating bottom cover for the welded housings, and push-on elements.

## Options

- Filter connection kit for easy mounting in series (10+ - 550+ l/s and 12-690 l/s).
- Wall mounting kit simplifies installation (10+ - 550+ l/s and 12-690 l/s).

For sizing and dimensions, please refer to the product pages of the DD(+) & PD(+) Series.

## Performance

	QD	QD+
Contaminant	Oil vapor	
Test method	ISO 8573-5:2001	
Maximum oil carry-over (mg/m <sup>3</sup> )*	0.003*	
Dry pressure drop (mbar)	190	140
Element service	After 1,000 operating hours or 1 year	
Precede with	Water separation DD/PD Dryer	Water separation UD+ or DD+/PD+ Dryer

\* After UD+ or DD(+)/PD(+) with inlet oil concentration of 10 mg/m<sup>3</sup>.

# SFA SERIES

## Silicone-free removal of oil aerosol, dust and oil vapor

Superb air purity is a prerequisite to safeguard your instruments and end product. Our silicone-free SFA filters efficiently prevent dry and wet dust, particulates, oil aerosol and water drops from entering your compressed air system. The SFA series is manufactured and treated according to the high standards of silicone-free equipment, and certified by the Fraunhofer Institute as guaranteed silicone-free.



## YOUR BENEFITS

### Maximum contaminant removal

Removal of dry and wet dust, particulates, oil aerosol and water droplets. High-efficiency glass fiber and fleece media.

### Significant energy savings & limited system operating costs

Optimal design and filter media allow for low pressure drops.

### High reliability

High-performance stainless steel cores, double O-rings, epoxy sealed caps and anti-corrosive coated filter housing.

### Easy maintenance

External ribs on the threaded housing and push-on elements.

### Monitoring of energy use

Differential pressure indication (indicator for sizes 9-32 l/s, gauge for sizes 44-520 l/s) (optional).

## Applications

- Painting
- Automotive

## Options

- Filter connection kit (9-520 l/s).
- Wall-mounting kit (9-520 l/s).
- Quick coupling (DD & PD only).
- EWD no-loss electronic drain (DD & PD only).
- Voltage-free contact mounted in the differential gauge (not for QD).

## Certification

Paint compatibility certificate (Fraunhofer Institute)



The performance of the SFA filters is comparable to the performance of the + range filters (please refer to pages 8, 10 and 14).

## Sizing & dimensions

FILTER SIZE	Nominal capacity*		Maximal capacity*		Connections G or NPT	Dimensions						Free space for cartridge replacement		Weight	
	l/s	cfm	l/s	cfm		in	A		B		C		D		kg
DD, DDp, PD, PDp, QD	l/s	cfm	l/s	cfm	in	mm	in	mm	in	mm	in	mm	in	kg	lbs
9	9	19	11	23	3/8	90	3.54	61	2.40	268	10.55	75	2.95	1	2.2
17	17	36	21	45	1/2	90	3.54	61	2.40	268	10.55	75	2.95	1.1	2.4
32	32	68	40	85	1/2	90	3.54	61	2.40	323	12.72	75	2.95	1.3	2.9
44	44	93	55	117	3/4 & 1	110	4.33	98.5	3.88	374	14.72	75	2.95	1.9	4.19
60	60	127	75	159	1	110	4.33	98.5	3.88	414	16.3	75	2.95	2.1	4.6
120	120	254	150	318	1-1/2	140	5.51	105	4.13	520	20.47	100	3.94	4.2	9.3
150	150	318	188	399	1-1/2	140	5.51	105	4.13	603	23.47	100	3.94	4.5	9.9
175	175	371	219	464	1-1/2	140	5.51	105	4.13	603	23.47	100	3.94	4.6	10.1
280	280	594	350	742	2 & 2-1/2	179	7.05	121	4.76	689	27.13	150	5.91	6.9	15.2
390	390	827	488	1035	3	210	8.27	128	5.04	791	31.14	200	7.87	11	24.2
520	520	1102	650	1378	3	210	8.27	128	5.04	961	37.83	200	7.87	12.6	27.8

\* Nominal pressure: 7 bar(e)/102 psig; temperature: 20°C, 68°F.



# H SERIES

## Guaranteed air purity up to 350 bar

High pressure filters efficiently reduce oil aerosol, dust and wet dust, particulates, water droplets and oil vapor in your compressed air stream to protect your investment, equipment and processes. Our innovative high pressure filtration solutions are engineered to cost effectively provide the best air purity and meet today's increasing quality demands up to working pressures of 350 bar. All high pressure filter housings are hydraulically tested to ensure safe and reliable operation at all times. A pressure test certificate accompanies each filter.



## YOUR BENEFITS

### Maximum contaminant removal (dry & wet dust, particulates, oil aerosol and water droplets)

High-efficient glass fiber and fleece media.

### Significant energy savings & limited system operation cost

Optimal design and filter media allow for low pressure losses.

### High reliability

High-performance stainless steel cores, double O-rings, epoxy sealed caps and anti-corrosive coated filter housing.

### Applications

- Chemical
- Food & beverage
- Manufacturing
- Military
- Oil & gas

## Performance

	DDHp+	PDHp+	DDH+	PDH+	QDH+
Contaminant	Dry dust		Oil aerosol/wet dust		Oil vapor
Test method	ISO 8573-4:2001 ISO 12500-3:2009		ISO 8573-2:2007 ISO 12500-1:2007		ISO 8573-5:2001
Maximum oil carry-over (mg/m <sup>3</sup> )	-	-	0.08*	0.007*	0.003**
Particle removal efficiency (% at MPPS)	99.92 (0.1)	99.98 (0.06)	N/A	N/A	N/A
Dry pressure drop (mbar)	85	100	N/A	N/A	140
Wet pressure drop (mbar)	N/A	N/A	180	215	N/A
Element service	After 4,000 operating hours or 1 year or 350 mbar pressure drop		After 4,000 operating hours or 1 year		After 1,000 operating hours or 1 year
Precede with	N/A	DDHp+	N/A	DDH+	DDH+/PDH+

Always install a liquid water separation system in front of a filter. Water separation is not needed in the high pressure line if there is a sufficiently low PDP in the low pressure line (e.g. nitrogen skid, low pressure line with adsorption dryer).

\* Inlet oil concentration = 10 mg/m<sup>3</sup>. Oil = oil aerosol and liquid.

\*\* After DD(+)/PD(+) with inlet oil concentration of 10 mg/m<sup>3</sup>.

## Sizing & dimensions

FILTER SIZE	Nominal capacity			Connections	Dimensions						Weight	
					A		B		C			
DDH, DDHp, PDH, PDHp, QDH	m³/h	l/s	cfm	in	mm	in	mm	in	mm	in	kg	lbs
<b>20 bar Aluminum</b>												
15+	54	15	32	3/8	90	3.5	61	2.4	268	10.6	1.0	2.2
32+	115	32	68	1/2	90	3.5	61	2.4	268	10.6	1.1	2.4
55+	198	55	117	1/2	90	3.5	61	2.4	323	12.7	1.3	2.9
80+	288	80	170	3/4 & 1	110	4.3	99	3.9	374	14.7	1.6	3.5
110+	396	110	233	1	110	4.3	99	3.9	414	16.3	2.1	4.6
200+	720	200	424	1 1/2	140	5.5	105	4.1	520	20.5	4.2	9.3
270+	972	270	572	1 1/2	140	5.5	105	4.1	603	23.7	4.5	9.9
330+	1188	330	699	1 1/2	140	5.5	105	4.1	603	23.7	4.6	10.1
490+	1764	490	1038	2 & 2 1/2	179	7.0	121	4.8	689	27.1	6.9	15.2
<b>50 bar Aluminum</b>												
160+	160	44	94	1/4	63	0.0	150	5.9	150	5.9	0.3	0.7
250+	250	69	147	3/8	63	2.5	190	7.4	190	7.4	0.3	0.7
450+	450	125	265	1/2	114	4.4	305	11.9	305	11.9	2.6	5.7
550+	550	153	324	3/4	114	4.4	305	11.9	305	11.9	2.6	5.7
835+	835	232	491	1	114	4.4	395	15.4	395	15.4	3.3	7.3
1250+	1250	347	736	1 1/2	146	5.7	435	17.0	435	17.0	7.5	16.5
1725+	1725	479	1015	1 1/2	146	5.7	435	17.0	435	17.0	7.5	16.5
1925+	1925	535	1133	2	146	5.7	435	17.0	435	17.0	7.5	16.5
3200+	3200	889	1883	2	146	5.7	635	24.8	635	24.8	10	22.0
<b>50 bar Stainless Steel</b>												
100+	100	28	59	1/4	85	3.3	202	7.9	202	7.9	1.7	3.7
200+	200	56	118	3/8	85	3.3	227	8.9	227	8.9	2	4.4
340+	340	94	200	1/2	85	3.3	257	10.0	257	10.0	2.2	4.8
500+	500	139	294	3/4	110	4.3	270	10.5	270	10.5	4	8.8
1000+	1000	278	589	1	110	4.3	422	16.5	422	16.5	5	11.0
1700+	1700	472	1000	1 1/2	150	5.9	517	20.2	517	20.2	15	33.1
2040+	2040	567	1200	2	150	5.9	517	20.2	517	20.2	15	33.1
3400+	3400	944	2000	2	150	5.9	817	31.9	817	31.9	21	46.3
<b>100 bar Stainless Steel</b>												
100+	100	28	59	1/4	65	2.5	135	5.3	135	5.3	3.2	7.1
315+	315	88	185	1/2	65	2.5	250	9.8	250	9.8	5.6	12.3
460+	460	128	271	3/4	88	3.4	275	10.7	275	10.7	6.1	13.4
680+	680	189	400	1	135	5.3	265	10.3	265	10.3	10.5	23.1
1200+	1200	333	706	1	135	5.3	480	18.7	480	18.7	14.7	32.4
1700+	1700	472	1000	1 1/2	150	5.9	525	20.5	525	20.5	22	48.5
3400+	3400	944	2000	2	150	5.9	815	31.8	815	31.8	28	61.7
<b>350 bar Stainless Steel</b>												
48+	48	13	28	1/4	41	1.6	103	4.0	103	4.0	1.6	3.5
111+	111	31	65	1/4	65	2.5	135	5.3	135	5.3	3.2	7.1
255+	255	71	150	1/2	88.5	3.5	210	8.2	210	8.2	5.6	12.3
510+	510	142	300	3/4	88.5	3.5	280	10.9	280	10.9	6.1	13.4
750+	750	208	441	1	150	5.9	330	12.9	330	12.9	14.5	32.0
1330+	1330	369	783	1	150	5.9	480	18.7	480	18.7	17.4	38.3

## Correction factors

<b>20 bar Aluminum</b>										
Operating pressure	barg	-	-	-	-	-	14	16	18	20
	psig	-	-	-	-	-	203	232	261	290
Correction factor							0.9	0.95	1	1.05
<b>50 bar Aluminum &amp; Stainless Steel</b>										
Operating pressure	barg	4	6	8	10	15	20	30	40	50
	psig	58	87	116	145	218	290	435	581	726
Correction factor		0.14	0.22	0.28	0.34	0.47	0.56	0.7	0.85	1
<b>100 bar Stainless Steel</b>										
Operating pressure	barg	20	30	40	50	60	70	80	90	100
	psig	290	435	581	726	871	1016	1161	1306	1451
Correction factor		0.45	0.57	0.68	0.8	0.84	0.88	0.92	0.96	1
<b>350 bar Stainless Steel</b>										
Operating pressure	barg	-	-	50	100	150	200	250	300	350
	psig	-	-	726	1451	2177	2903	3628	4354	5080
Correction factor				0.73	0.78	0.82	0.87	0.91	0.96	1



### Example

- Working pressure 300 bar(g), compressed air flow 500 m³/h.
- Multiply the nominal capacity of the selected filter with the corresponding correction factor at the required working pressure to obtain the capacity at working pressure:
  - Size 510+: 510 m³/h \* 0.96 = 490 m³/h => the 510+ filter size is not large enough.
  - Size 750+: 750 m³/h \* 0.96 = 720 m³/h => the 750+ filter size is the size to select.

# MV SERIES

## Medical vacuum filters for optimal protection of man and machine

Medical vacuum filters are installed at the inlet of the vacuum pump to remove any liquid, solid or bacterial contamination which could damage the vacuum pump and biologically infect the downstream air.

Our innovative medical vacuum filtration solutions comply with HTM medical standards.



## YOUR BENEFITS

### Maximum contaminant removal

Removal of dry and wet dust, particulates, oil aerosol and water droplets. High-efficiency glass fiber and fleece media.

### Significant energy savings & limited system operation cost

Optimal design and filter media allow for low pressure losses.

### High reliability

High performance stainless steel cores, double O-rings, epoxy sealed caps and anti-corrosive coated filter housing.

### Easy maintenance

External ribs on the threaded housing and push-on elements.

### Monitoring of energy use

Differential pressure indication show the pressure loss.

## Applications

- Medical
- Dental
- Veterinary

## Performance

	MV
Contaminant	Dry dust
Maximum temperature	60°C/140°F
Maximum working vacuum	Full vacuum
Test method	Sodium flame test BS 3928:1969, based on requirements of HTM2022
Particle removal efficiency (%)*	99.995
Dry pressure drop (mbar)	30
Element service	After 2,000 operating hours or 1 year or 100 mbar pressure drop

\* In accordance with BS 3928-1969.

## Sizing & dimensions

FILTER SIZE MV	Nominal Capacity	Connections	Dimensions						Weight	
			A		B		C			
			l/min	in	mm	in	mm	in	mm	in
10	400	1/2	60	2	90	4	240	9	1.3	2.9
20	800	1	76	3	110	4	300	12	2.1	4.6
60	2400	1 1/2	103	4	140	5	489	19	4.6	10.1
80	3400	2	135	5	179	7	575	22	6.9	15.2
120	4900	3	155	6	210	8	677	26	11.0	24.2
160	6700	3	155	6	210	8	847	33	12.6	27.8

## Correction factors

Operating pressure	bar(a)	0.1	0.2	0.3	0.4	0.5	0.6	0.7	0.8	0.9	1
	Psig	1	3	4	6	7	9	10	12	13	15
	Torr = mm Hg	75	150	225	300	375	450	525	600	675	750
Correction factor		0.1	0.2	0.3	0.4	0.5	0.6	0.7	0.8	0.9	1

### Example

- Working vacuum 300 mbar(a), capacity 1,000 l/min.
- Multiply the nominal capacity of the selected filter with the corresponding correction factor at the required working vacuum to obtain the correct capacity:
  - Size 60: 2,400 l/min \* 0.3 = 720 l/min => the 60 filter size is not large enough.
  - Size 80: 3,400 l/min \* 0.3 = 1,020 l/min => the 80 filter size is the size to select.



## Options

- Wall mounting kit.
- Drain flask.



Drain flask



## Certification

BS 3928 Sodium flame test certificate based on requirements of HTM2022.

## ***COMMITTED TO SUSTAINABLE PRODUCTIVITY***

We stand by our responsibilities towards our customers, towards the environment and the people around us. We make performance stand the test of time. This is what we call – Sustainable Productivity.



[www.atlascopco.com](http://www.atlascopco.com)



## DD DDp PD PDp QD

### ATLAS COPCO COMPRESSED AIR FILTER

---

Atlas Copco offers a range of filters to reduce all types of contamination in compressed air process. Designed for maximum contaminant removal and minimal pressure drop, Atlas Copco filters offer significant energy savings in the compressed air system as well as minimising the problems that result from poor air quality.



The +range filters, which comply with ISO 12500-1:2007 and ISO 8573-2:2007 standards, do not only offer an industry leading air purity, but also focus on lifecycle cost.

DD & DD+ refer to coalescing filters for general purpose protection, removing solid particles, liquid water and oil aerosol. Total mass efficiency 0.01  $\mu\text{m}$  99.93 %.

DDp & DDp+ refer to particle filters for dust protection. Total mass efficiency 0.01  $\mu\text{m}$  99.93 %.

PD & PD+ refer to high efficiency coalescing filters, removing solid particles, liquid water and oil aerosol. Total mass efficiency 0.01  $\mu\text{m}$  99.99 %.

PDp & PDp+ refer to high efficiency particle filter for dust protection. Total mass efficiency 0.01  $\mu\text{m}$  99.99 %.

QD & QD+ refer to active carbon filters for removal of oil vapours and hydrocarbon odours with a maximum remaining oil content of 0.003 mg/m<sup>3</sup> (0,003ppm). Should be installed after a PD or PD+ filter.

## Your benefits

### Excellent reliability

Enhanced perforated stainless steel cores ensure ultimate strength and terminates the risk of implosion. The filter will never generate rust particles itself.

### Obvious energy saving

A unique internal design of Atlas Copco equips filters an ideal flow path and hence a low pressure drop.

### Easy installation

Compact size of Atlas Copco filters require minimum installation space and minimal free space for cartridge change.

### Low maintenance cost

A special rotating system for the bottom cover helps our service technician for an easy maintenance.

### Quality and reliability



### **Double O-rings ①**

- Reduce leakage risks for a high reliability

### **Push-on element ②**

- Simplify installation and maintenance and increases reliability

### **Stainless steel filter cores ③**

- Ultimate strength and no risk for implosion

### **Protection paper ④**

- Avoid damaging glass fibers

### **New enhanced glass fiber media and impregnated activated carbon layers ⑤**

- Work together to remove oil coalescence and dust and oil vapor

### **Open foam (not for QD and QD+) ⑥**

- Drain liquid

### **Epoxy sealed caps ⑦**

- Reduce leakage risks

## **Working principle**



## **Inertial Impaction**

Large particles travel in a straight line and impact the filter media. Air travels around and through the filtration media.

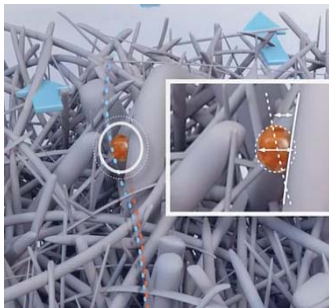

## Interception

Smaller particles follow air but when the particle size is greater than the gap of the fibers, the contamination is trapped and removed from the air flow.

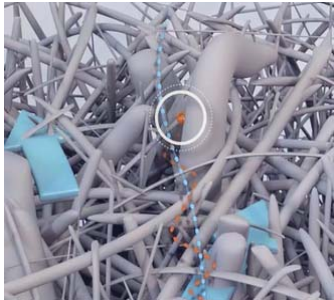

## Diffusion

The smallest particles do not follow the air flow but move randomly, which is called Brownian motion. As the particles move around they impact the filter media and are removed from the air flow.

### Standard scope of supply

- Head
- Bowl
- Filter element(s)
- Differential pressure gauge
- Automatic drain (not for QD, QD+, DDp, DDp+, PDp, PDp+)
- Manual drain (not for QD, QD+, DDp, DDp+, PDp, PDp+)
- Sight glass (cast versions only)ss

### Features and benefits

- Differential pressure gauge
  - Indicates optimum replacement time and minimizes pressure drop in system
- Internally and externally coated
  - Prevents corrosion and ensures extra-long lifetime
- EWD automatic drain prevents condensate build up in filter
  - Automatically drains collected liquid and can be easily piped away to condensate management system

# Medical Sterile Filters



**16 models specifically designed and manufactured to exceed the requirements of UK Health Technical Memorandum 02-01 for medical gas pipeline systems.**

The Alpha Series medical sterile filters offer connections from 1/4" to 3", flows of up to 1500 SCFM (2550 Nm<sup>3</sup>/h) and feature the Walker E-Coat™ finish for corrosion protection. The optimised modular design allows for multiple close coupling and is easy to install and maintain. The range is manufactured from cast aluminium alloy offering enhanced strength and robustness.

**Intelligent, unique design for optimised performance**

Medical sterile elements are guaranteed for a minimum of 100 sterilisations at 120°C (248°F), each element must be autoclaved before commencement of duty.

**Elements are 100% integrity tested**

Elements are constructed with stainless steel endcaps for compatibility with autoclave sterilisation. 100% integrity tested, each element is supplied with an Air Sterilisation certificate to guarantee the highest quality to our customers.

**Tested and validated to international standards**



## Applications include

Dental

Medical

Veterinary



# Technical Specification

filter model	pipe size	flow rate*		dimensions (mm)				weight Kg	element model
		Nm <sup>3</sup> /h	SCFM	A	B	C	D		
A019 MS	¼	25.5	15	50	18	152	75	0.5	E0305 SR
A028 MS	¼	42.5	25	70	25	191	85	0.8	E0407 SR
A038 MS	⅜	59.5	35	70	25	191	95	0.8	E0407 SR
A058 MS	½	85.0	50	70	25	232	135	0.9	E0413 SR
A059 MS	½	119	70	100	35	276	155	2.0	E0613 SR
A078 MS	¾	144	85	100	35	276	155	2.0	E0613 SR
A109 MS	1	297	175	100	35	396	275	2.4	E0625 SR
A128 MS	1¼	476	280	122	42	460	320	3.3	E0730 SR
A158 MS	1½	545	320	122	42	460	320	3.3	E0730 SR
A159 MS	1½	680	400	146	52	482	325	4.9	E0830 SR
A208 MS	2	765	450	146	52	482	325	4.9	E0830 SR
A209 MS	2	1190	700	146	52	785	630	7.0	E0860 SR
A254 MS	2½	1445	850	210	66	595	410	9.6	E1140 SR
A340 MS	3	1530	900	210	66	595	410	9.6	E1140 SR
A360 MS	3	2125	1250	210	66	815	630	11.6	E1160 SR
A390 MS	3	2550	1500	210	66	975	785	13.1	E1175 SR

\* Rated flow at 7 barg, reference conditions 1 bar (a) 20°C

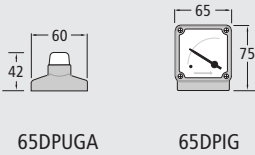

65DPUGA

65DPIG

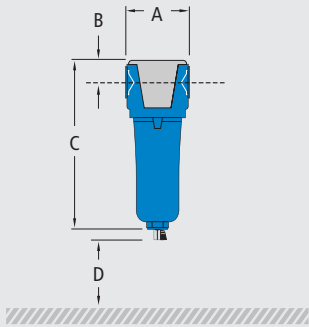

A019 MS to A390 MS

	SR	
DOP efficiency**	>99.9999%	
Particle removal	0.01 micron	
Maximum operating temperature (recommended)	120°C (50°C)	248°F (122°F)
Pressure loss - clean	100 mbar	1.5 psi
Pressure loss - change element	400 mbar	6 psi
Maximum autoclave temperature	134°C	273°F
Maximum working pressure	16 barg	232 psig
Element end cap material	stainless steel	

\*\* as specified in HTM 02-01 medical gas pipeline systems

### pressure correction factors

for maximum flow rate, multiply model flow rate by the correction factor corresponding to the minimum operating pressure

Operating pressure barg (psig)	4 (58)	5 (72)	6 (87)	7 (100)	8 (115)	10 (145)	12 (174)	14 (203)	16 (232)
7 barg - correction factor	0.76	0.84	0.92	1.00	1.07	1.19	1.31	1.41	1.51

### technical notes

- 1 Filter element endcaps are stainless steel.
- 2 Direction of air flow is outside to in through the filter element.
- 3 Pop up indicators (65DPUG) are fitted to models A028 MS, A038 MS and A058 MS as standard. Differential pressure indicators (65DPIG) are fitted to models A059 MS to A390 MS as standard.
- 4 Manual drain valves are fitted to all models. Models A059 MS to A390 MS can be adapted to use ¼" drains with a reducer.
- 5 Medical sterile filter elements must not operate in water or oil saturated conditions.
- 6 Maximum steam sterilising temperature refers to the filter element ONLY. Grade SR filter elements can be steam sterilised 100 times. Each element must be autoclaved before commencement of duty.
- 7 Pre filtration should be used in conjunction with 0.01 micron sterile filters.
- 8 Threaded filters are manufactured from cast aluminium alloy and are PED 97/23/EC compliant for group 2 gases.
- 9 Threaded connections are Rp (BSP parallel) to ISO 7/1 or NPT to ANSI B2.1 if supplied within North America.
- 10 For NPT connections, add the suffix N e.g. A018MSN.
- 11 Filter elements should be changed every 6 months / 1000 hours (whichever comes first).
- 12 Filters are suitable for use with mineral and synthetic oils, plus oil-free compressed air applications.