

CERTIFIKÁT EÚ SKÚSKY TYPU

EU – type examination certificate

Číslo dokumentu:
Document number:

SK 24-MI001-SMU076
Revízia 2 nahrádza certifikát zo dňa 18. decembra 2024
Revision 2 replaces the certificate issued by December 18, 2024

Revízia 2
Revision 2

V súlade s:
In accordance with:

prílohou č. 2, Modul B nariadenia vlády Slovenskej republiky č. 145/2016 Z. z. o sprístupňovaní meradiel na trhu v znení nariadenia vlády SR č. 328/2019 Z. z., ktorým sa preberá smernica Európskeho parlamentu a Rady 2014/32/EU o harmonizácii právnych predpisov členských štátov týkajúcich sa sprístupnenia meradiel na trhu
Annex II, Module B to Government Ordinance of the Slovak Republic No. 145/2016 Coll. Relating to the making available on the market of measuring instruments as amended by Government Ordinance of the Slovak Republic No. 328/2019 Coll., which implemented the Directive 2014/32/EU of the European Parliament and of the Council on the harmonisation of the laws of the Member States relating to the making available on the market of measuring instruments

Žiadateľ/Výrobca:
Issued to (Manufacturer):

Apator Powogaz S. A.
Jaryszki 1C, 62-023 Żerniki, Poland

Druh meradla:
Type of instrument:

Vodomer (MI-001)
Water meter (MI-001)

Označenie typu:
Type designation:

Ultrimis Neo (ULN)

Základné požiadavky:
Essential requirements:

príloha č. 1 a príloha č. 3 Vodomery (MI-001) k nariadeniu vlády SR č. 145/2016 Z. z. v znení nariadenia vlády SR č. 328/2019 Z. z.
Annex No. I and Annex No. III Water meters (MI-001) to Government Ordinance of the Slovak Republic No. 145/2016 Coll. as amended by Government Ordinance of the Slovak Republic No. 328/2019 Coll.

Platnosť do:
Valid until:

28. mája 2034
May 28, 2034

Notifikovaná osoba:
Notified body:

Slovenský metrologický ústav 1781
Slovak Institute of Metrology 1781

Dátum vydania:
Date of issue:

11. júna 2026
June 11, 2026

Základné charakteristiky, popis meradla a podmienky schválenia sú uvedené v prílohe, ktorá je súčasťou tohto certifikátu. Certifikát vrátane prílohy má spolu 15 strán.

Essential characteristics, instrument description and approval conditions are set out in the appendix hereto, which forms the part of the certificate. The certificate including the appendix contains 15 pages.

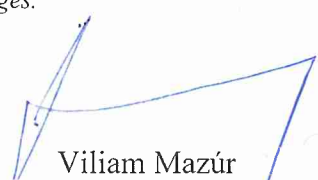

Viliam Mazúr
zástupca notifikovanej osoby
representative of notified body

Poznámka: Tento certifikát EÚ skúšky typu môže byť rozmnožovaný len celý a nezmenený. Bez podpisu a odtlačku pečiatky je neplatný.
Note: This EU-type examination certificate shall not be reproduced except in full. Certificates without signature and stamp are not valid.



Issue of the Certificate	Date	Modifications
SK 24-MI001-SMU076, Revision 0	May 28, 2024	Initial certificate
SK 24-MI001-SMU076, Revision 1	December 18, 2024	Adding DN25-DN50
SK 24-MI001-SMU076, Revision 2	June 11, 2026	Adding new SW version 03.01

1 Instructions and standards used within assessment

1.1 Generally binding instructions

Meter type was examined in terms of request for given type provisions Government Ordinance of the Slovak Republic No. 145/2016 Coll. relating to the making available on the market of measuring instruments as amended by Government Ordinance of the Slovak Republic No. 328/2019 Coll., which implemented the Directive 2014/32/EU of the European Parliament and of the Council of 26 February 2014 on the harmonisation of the laws of the Member States relating to the making available on the market of measuring instruments as later amended (next Government Ordinance).

Requirements are set out in Annex No. 1 and Annex No. 3 Water Meters (MI-001) to Government Ordinance of SR No. 145/2016 Coll. as amended by Government Ordinance of the Slovak Republic No. 328/2019 Coll.

1.2 Technical specification used:

OIML R 49-1:2013	Water meters intended for the metering of cold potable water and hot water. Part 1: Metrological and technical requirements
OIML R 49-2:2013	Water meters intended for the metering of cold potable water and hot water. Part 2: Test methods
OIML R 49-3:2013	Water meters intended for the metering of cold potable water and hot water. Part 3: Test report format
EN ISO 4064-1:2017	Water meters for cold potable water and hot water. Part 1: Metrological and technical requirements
EN ISO 4064-2:2017	Water meters for cold potable water and hot water. Part 2: Test methods
EN ISO 4064-3:2014	Water meters for cold potable water and hot water. Part 3: Test report format
EN ISO 4064-5:2017	Water meters for cold potable water and hot water. Part 5: Installation requirements
WELMEC Guide 7.2:2025	Software Guide

2 Type marking

Ultrasonic water meter – Ultrimis Neo (ULN)

Meter is made in following subgroups:

Type of meter	Temperature class	Classes	Nominal Diameter
Ultrimis Neo (ULN)	T30, T50, T70	M1 ⁽¹⁾ B or O ⁽²⁾ E1 or E2 ⁽¹⁾	DN15, DN20, DN25, DN32, DN40, DN50

¹ according to Government Ordinance of the Slovak Republic, Annex No. 1

² according to EN ISO 4064-1:2017 and OIML R 49-2:2013



3 Description of measuring instrument

Meter name: Ultrimis Neo

Type marking: ULN

Description of operating principle instrument design:

The ultrasonic water meters type Ultrimis Neo (ULN) is an ultrasonic water meter with an electronic indicating device that is designed to measure, memorise and display the volume at metering conditions of water passing through the measurement transducer.

The water meter consists of a brass or composite body with connection thread or flange, one pair of compact ultrasonic transducers and the electronic indicating device. The electronic indicating device shows on LCD display volume, current flow and other information (Picture No. 2). The water meter has two indication modes: normal resolution mode (0,001 m³) and high-resolution mode (0,00001 m³, which is used during the calibration process).

The family of the water meter is ranged from DN15 up to DN50 with measuring range up to R2000. The water meters, which measuring range is equal or less than R800, may or may not measure reverse flow, depending on factory set-up. The measuring range above R800 can be applied only to forward flow.



Picture No. 1 Ultrasonic water meter Ultrimis Neo (ULN)

The water meter can operate in any position without consequences on accuracy. Pipes must always be filled with water when the device is counting. The adjustment and reading/setting of metrological data is done electronically using NFC communication protocol. The access to the metrological parameters is secured by multileveled passwords combination. Communication with meter is possible using ISM radio bands and used frequency is marked on the register. There is a possibility of one or two-way communication based on wM-Bus and/or LoRaWAN protocols. Depending on factory configuration, the meter can additionally be equipped with a strainer or a check valve.

3.1 Description of subgroups

Marking: ULNXX / ULNXX-01
DN: DN15, DN20, DN25, DN32, DN40, DN50
where XX – permanent flow Q_3 ;
01 – composite body.

3.2 Flow sensor

The main elements of the measuring organ are:

- brass or composite body with connection thread;
- flow tube (measuring insert) with mirror setup;
- pair of compact ultrasonic transducers (part of the electronic indicating device).

Depending on the configuration the device can be equipped with a strainer which does not affect the measurement.

The set of above elements is forming the measuring device, in which the flow tube is profiling the water flow to a stream, flowing through the sound path. The sound path, between the ultrasonic transducers is profiled by the reflective mirrors, which multiplies its length, and covers the whole flow profile. There are no moving parts.

There are two types of flow tubes (measuring insert) for DN15 and DN20, can be used depending on factory configuration:

- flow tube v.1 can be used for temperature classes T30 and T50 with pressure loss class Δp_{40} (technical drawing of measuring insert no. 5025-010100 for DN15 and no. 5045-010100 for DN20);

- flow tube v.2 can be used for temperature classes T30, T50 and T70 with pressure loss class Δp_{25} (technical drawing of measuring insert no. 5120-010300 for DN15 and no. 5040-010300 for DN20).

There is one type of flow tube for temperature classes T30, T50 for:

- DN25, with pressure loss class Δp_{40} (technical drawing of measuring insert no. 5055-10100);
- DN32, with pressure loss class Δp_{40} (technical drawing of measuring insert no. 5065-10100);
- DN40, with pressure loss class Δp_{25} (technical drawing of measuring insert no. 5070-10100);
- DN50, with pressure loss class Δp_{25} (technical drawing of measuring insert no. 5080-10200).

3.3 Indicating device (calculator)

The main elements of calculator are:

- plastic housing (cup) with built-in (compact) ultrasonic transducers;
- glass-covered housing;
- locking ring (which seals the meter);
- mainboard (PCBA) with LCD display, one or two batteries (depending on factory configuration), integrated radio and tamper switch;
- NFC antenna;
- front plate;
- desiccant;
- connector.

The electronic device operates the ultrasonic transducers, calculate the flow and integrates the water volume. The calculator display shows the total volume, current flow and other necessary information.



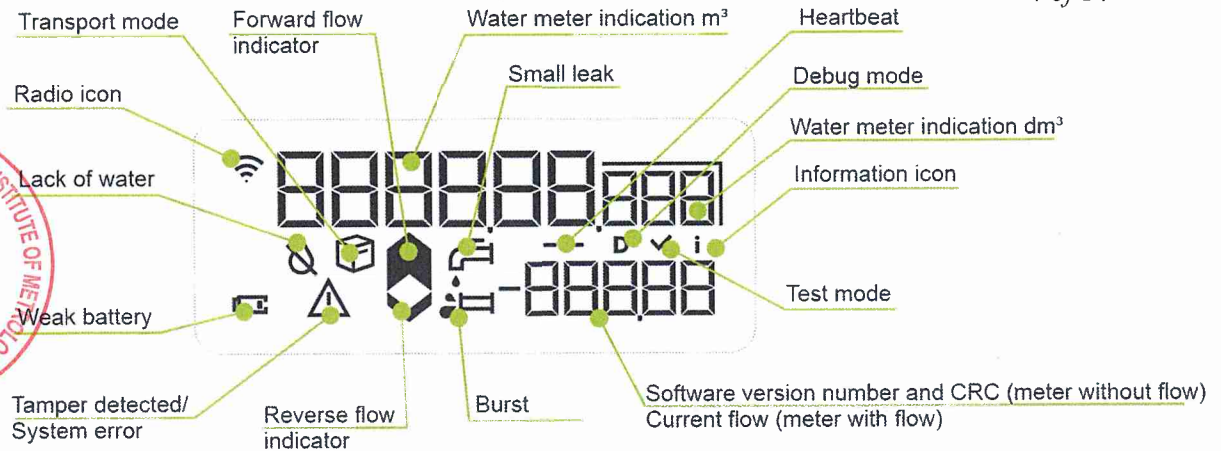

Picture No. 2 LCD Screen

3.4 Principle of operation

The ultrasonic water meter uses two transducers that can operate as both transmitter and receiver of ultrasound. The ultrasound is transmitted between the transducers via profiled sound path through the water. The transit time between the transducers is measured in both up- and downstream directions.

If there is no fluid motion, the transit time in both directions is the same.

If there is fluid motion, it will cause a difference in transit times in both directions, which is proportional to the water flow. The flow rate can be integrated as the indicated volume of the water.

3.5 Technical documentation

A number of drawings of technical documentations is listed in the following list:

Drawing number	Title	Drawing number	Title	Drawing number	Title
5020-010101	Body DN15 L110	5120-010300	Measuring insert DN15 (T70)	5145-010000	Measuring organ DN20-01 L130 (T70)
5020-310101	Body DN15 L110 with strainer	5020-010000	Measuring organ DN15 L110 (T50)	5045-310000	Measuring organ DN20-01 L130 with strainer (T50)
5025-010101	Body DN15-01 L110	5120-010000	Measuring organ DN15 L110 (T70)	5145-310000	Measuring organ DN20-01 L130 with strainer (T70)
5040-010101	Body DN20 L130	5020-310000	Measuring organ DN15 L110 with strainer (T50)	5130-010000	Measuring organ UL2,5 DN20 L130 (T70)
5040-310101	Body DN20 L130 with strainer	5120-310000	Measuring organ DN15 L110 with strainer (T70)	9050-010002	Strainer DN15
5045-010101	Body DN20-01 L130	5025-010000	Measuring organ DN15-01 L110 (T50)	9070-010002	Strainer DN20
5300-210000	Indicating device (calculator assembly) ULN	5125-010000	Measuring organ DN15-01 L110 (T70)	5310-000000	Water meter ULN2,5 DN15 L110 T70
5025-010001	Inlet ring	5025-310000	Measuring organ DN15-01 L110 with strainer (T50)	5300-000000	Water meter ULN2,5 DN15 L110 T50
5025-000004	Locking pin (composite)	5125-310000	Measuring organ DN15-01 L110 with strainer (T70)	5311-000000	Water meter ULN2,5-01 DN15 L110 T70



Drawing number	Title	Drawing number	Title	Drawing number	Title
5020-000004	Locking pin (brass)	5040-010000	Measuring organ DN20 L130 (T50)	5301-000000	Water meter ULN2,5-01 DN15 L110 T50
5300-210002	Locking ring	5140-010000	Measuring organ DN20 L130 (T70)	5312-000000	Water meter ULN4 DN20 L130 T70
5025-010100	Measuring insert DN15 (T50)	5040-310000	Measuring organ DN20 L130 with strainer (T50)	5302-000000	Water meter ULN4 DN20 L130 T50
5045-010100	Measuring insert DN20 (T50)	5140-310000	Measuring organ DN20 L130 with strainer (T70)	5313-000000	Water meter ULN4-01 DN20 L130 T70
5140-010300	Measuring insert DN20 (T70)	5045-010000	Measuring organ DN20-01 L130 (T50)	5303-000000	Water meter ULN4-01 DN20 L130 T50
0000-001685	Strainer DN25	5305-000000	Water meter ULN10	5081-010000	Measuring organ DN50 L270 flanged
5050-010000	Measuring organ DN25 L260	0000-001684	Strainer DN40	5081-020000	Measuring organ DN50 L270 G2 1/2
5050-310000	Measuring organ DN25 L260 with strainer	5070-010000	Measuring organ DN40 L300	5081-310000	Measuring organ DN50 L270 flanged with strainer
5051-010000	Measuring organ DN25 L165	5070-310000	Measuring organ DN40 L300 with strainer	5081-320000	Measuring organ DN50 L270 G2 1/2 with strainer
5051-310000	Measuring organ DN25 L165 with strainer	5070-010100	Measuring insert DN40	5082-010000	Measuring organ DN50 L300 flanged
5055-010100	Measuring insert DN25	5306-000000	Water meter ULN16	5082-020000	Measuring organ DN50 L300 G2 1/2
5304-000000	Water meter ULN6,3	0000-001680	Strainer DN50	5082-310000	Measuring organ DN50 L300 flanged with strainer
0000-001686	Strainer DN32	5080-010000	Measuring organ DN50 L200 flanged	5082-320000	Measuring organ DN50 L300 G2 1/2 with strainer
5060-010000	Measuring organ DN32 L260	5080-020000	Measuring organ DN50 L200 G2 1/2	5080-010100	Measuring insert DN50
5060-310000	Measuring organ DN32 L260 with strainer	5080-310000	Measuring organ DN50 L200 flanged with strainer	5307-000000	Water meter ULN25
5065-010100	Measuring insert DN32	5080-320000	Measuring organ DN50 L200 G2 1/2 with strainer	5300-220000	Indicating device (calculator assembly) ULN 02.00
5300-230000	Electronic Converter Unit ULNTA3	5300-230400	Electronic module with switch ULNTA3	5300-230500	Electronic Module Set ULNTA3

A number of drawings, schemes and technical documentations used during the conformity assessment is saved in documents No. NO-611/23, NO-642/24 and NO-704/26.



4 Basic technical characteristics

Type marking		ULN1,6 / ULN2,5	ULN4	ULN6,3
Nominal diameter	mm	15 / 20	20	25
Indicating range	m ³	999 999		
Resolution of reading	m ³	0,001		
Maximum admissible pressure	-	MAP16, MAP10		
Working pressure range	bar	from 0,3 to 16 (from 0,3 to 10 for MAP10)		
Pressure loss class ⁽³⁾	-	Δp25 / Δp40		Δp40
Temperature class ⁽³⁾	-	T30, T50, T70		T30, T50
Flow profile sensitivity class	-	U0, D0		
Position	-	no limitation		
Climatic environment	-	Indoors, outdoors, from -10°C to 70°C		
Information specified by the manufacturer				
Electromagnetic class		E1 or E2		
Environmental class		B or O		
Mechanical class		M1		
EUT testing requirements (OIML R 49-2:2013, 8.1.8)				
Category		Ultrasonic water meters		
Case		B		

³ depending on factory configuration or setup



Type marking		ULN6,3 / ULN10	ULN16	ULN25
Nominal diameter	mm	25 / 32	40	50
Indicating range	m ³	999 999		
Resolution of reading	m ³	0,001		
Maximum admissible pressure	-	MAP16, MAP10		
Working pressure range	bar	from 0,3 to 16 (from 0,3 to 10 for MAP10)		
Pressure loss class ⁽³⁾	-	Δp25 / Δp40	Δp25	
Temperature class ⁽³⁾	-	T30, T50		
Flow profile sensitivity class	-	U0, D0		
Position	-	no limitation		
Climatic environment	-	Indoors, outdoors, from -10°C to 70°C		
Information specified by the manufacturer				
Electromagnetic class		E1 or E2		
Environmental class		B or O		
Mechanical class		M1		
EUT testing requirements (OIML R 49-2:2013, 8.1.8)				
Category		Ultrasonic water meters		
Case		B		



4.1 Additional technical characteristics

Weight [kg]	0,18 – 0,68
Environmental protection (IP Code)	IP68
Power source	Lithium battery, 3 V DC (1 or 2 integrated batteries ⁽³⁾), battery lifetime is displayed on the front plate
Battery lifetime	minimum 10 years ⁽³⁾
Outputs	NFC communication Radio communication ISM band @ 868MHz (wM-Bus, LoRaWAN)
Display	LCD, 9 digits
Resolution of the device for rapid testing	0,00001
Software	Type P, Risk class C, Extensions T, S (WelmeC Guide 7.2)
Software version and checksum	01.00; checksum C16A75AB ⁽⁴⁾ 01.01; checksum 03110DEF ⁽⁴⁾ 02.00; checksum D0FB64E5 ⁽⁴⁾ 03.01; checksum 8DF50F50 ⁽⁴⁾

⁴ due to the LCD screen limitations, letters 'B' and 'D' will be displayed as 'b' and 'd' accordingly

5 Basic metrological characteristics

The maximum permissible error (accuracy class):

$$\pm 5 \% (Q_1 \leq Q < Q_2)$$

$$\pm 2 \% (Q_2 \leq Q \leq Q_4) \text{ for water temperature (from 0,1 to 30) } ^\circ\text{C}$$

$$\pm 3 \% (Q_2 \leq Q \leq Q_4) \text{ for water temperature greater than 30 } ^\circ\text{C}$$



Nominal diameter DN		15 / 20								
Overload flow rate Q_4	[m ³ /h]	2								
Permanent flow rate Q_3	[m ³ /h]	1,6								
Transitional flow rate Q_2	[m ³ /h]	0,00204	0,0025	0,003	0,006	0,0102	0,01	0,025	0,03	
		8	6	2	4	4	6	6	2	
Minimum flow rate Q_1	[m ³ /h]	0,00128	0,0016	0,002	0,004	0,0064	0,01	0,016	0,02	
Measuring range Q_3/Q_1	-	1250	1000	800	400	250	160	100	80	
Pressure loss class ⁽³⁾	-	$\Delta p_{25} / \Delta p_{40}$								
Ratio Q_2/Q_1	-	1,6								

Nominal diameter DN		15 / 20									
Overload flow rate Q_4	[m ³ /h]	3,125									
Permanent flow rate Q_3	[m ³ /h]	2,5									
Transitional flow rate Q_2	[m ³ /h]	0,002	0,0025	0,00	0,00	0,00	0,01	0,01	0,02	0,04	0,05
				32	40	50	00	60	50	00	
Minimum flow rate Q_1	[m ³ /h]	0,001	0,00156	0,00	0,00	0,00	0,00	0,01	0,01	0,02	0,031
		25	25	2	25	31	63	00	56	50	25
Measuring range Q_3/Q_1	-	2000	1600	1250	1000	800	400	250	160	100	80
Pressure loss class ⁽³⁾	-	$\Delta p_{25} / \Delta p_{40}$									
Ratio Q_2/Q_1	-	1,6									

Nominal diameter DN		20									
Overload flow rate Q_4	[m ³ /h]	5									
Permanent flow rate Q_3	[m ³ /h]	4									
Transitional flow rate Q_2	[m ³ /h]	0,003	0,004	0,005	0,006	0,008	0,016	0,025	0,040	0,064	0,126
		2		12	4	0	0	6	0	0	
Minimum flow rate Q_1	[m ³ /h]	0,002	0,002	0,003	0,004	0,005	0,010	0,016	0,025	0,040	0,078
			5	2	0	0	0	0	0	0	75
Measuring range Q_3/Q_1	-	2000	1600	1250	1000	800	400	250	160	100	80
Pressure loss class ⁽³⁾	-	$\Delta p_{25} / \Delta p_{40}$									
Ratio Q_2/Q_1	-	1,6									



Nominal diameter DN		25					
Overload flow rate Q_4	[m ³ /h]	7,875					
Permanent flow rate Q_3	[m ³ /h]	6,3					
Transitional flow rate Q_2	[m ³ /h]	0,013	0,025	0,040	0,063	0,101	0,126
Minimum flow rate Q_1	[m ³ /h]	0,008	0,016	0,025	0,039	0,063	0,07875
Measuring range Q_3/Q_1	-	800	400	250	160	100	80
Pressure loss class	-	Δp40					
Ratio Q_2/Q_1	-	1,6					

Nominal diameter DN		25 / 32					
Overload flow rate Q_4	[m ³ /h]	12,5					
Permanent flow rate Q_3	[m ³ /h]	10					
Transitional flow rate Q_2	[m ³ /h]	0,020	0,040	0,064	0,100	0,160	0,200
Minimum flow rate Q_1	[m ³ /h]	0,013	0,025	0,040	0,063	0,100	0,125
Measuring range Q_3/Q_1	-	800	400	250	160	100	80
Pressure loss class ⁽³⁾	-	Δp25 / Δp40					
Ratio Q_2/Q_1	-	1,6					

Nominal diameter DN		40					
Overload flow rate Q_4	[m ³ /h]	20					
Permanent flow rate Q_3	[m ³ /h]	16					
Transitional flow rate Q_2	[m ³ /h]	0,032	0,064	0,102	0,160	0,256	0,320
Minimum flow rate Q_1	[m ³ /h]	0,020	0,040	0,064	0,100	0,160	0,200
Measuring range Q_3/Q_1	-	800	400	250	160	100	80
Pressure loss class	-	Δp25					
Ratio Q_2/Q_1	-	1,6					

Nominal diameter DN		50						
Overload flow rate Q_4	[m ³ /h]	31,3						
Permanent flow rate Q_3	[m ³ /h]	25						
Transitional flow rate Q_2	[m ³ /h]	0,050	0,080	0,100	0,160	0,25	0,4	0,500
Minimum flow rate Q_1	[m ³ /h]	0,03125	0,050	0,063	0,100	0,156	0,25	0,3125
Measuring range Q_3/Q_1	-	800	500	400	250	160	100	80
Pressure loss class	-	Δp25						
Ratio Q_2/Q_1	-	1,6						



6 Results of conformity assessment

The results of tests, assessments and evaluations given in the evaluation report No. NO-704/26/B/ER dated June 10, 2026 give sufficient evidence, that the technical design of the measuring instrument – ultrasonic water meter type Ultrimis Neo (ULN) is in compliance with the technical requirements of the Slovak Republic Governmental Ordinance No. 145/2016 Coll. relating to the making available on the market of measuring instruments as amended by Government Ordinance of the Slovak Republic No. 328/2019 Coll. Annex No. 1 and Annex No. 3 Water Meters (MI-001) and with the requirements determined in EN ISO 4064-1:2017, respectively OIML R 49-1:2013, which are relevant for this type of meter.

7 Data placed on the measuring instrument

On the shroud, the dial of the indicating device (shown on Picture No. 3) or on an identification plate of every water meter or in the product documentation minimum the following data should be marked:

- a) manufacturer’s name, registered trade name or registered trade mark
- b) postal address of manufacturer at which they can be contacted
- c) type of the ultrasonic water meter
- d) measuring unit (m³)
- e) numerical value of Q_3 in m³/h (Q_3 x,x) and ratio Q_3/Q_1 (Rxxx)
- f) year of production
- g) production serial number
- h) number of EU-type examination certificate and conformity mark
- i) the highest admissible pressure if it differs from 1 MPa (MAP xx)
- j) flow direction
- k) the letter V or H, if the meter can only be operated in the vertical or horizontal position
- l) the temperature class where it differs from T30
- m) class of pressure loss if it differs from Δp_{63} (Δp XX)
- n) environmental classification.
- o) the installation sensitivity class where it differs from U0/D0 ($U_x D_x$)
- p) electromagnetic environmental class
- q) for a non-replaceable battery: the latest date by which the meter shall be replaced
- r) software version, checksum



Picture No. 3 Front plate and LCD display

8 Conditions of conformity assessment of measuring instruments produced with type approval

Ultrasonic water meter put onto the market in line with the procedure of conformity assessment according to the Annex No. 2 (Module D or F) of the Governmental ordinance should be in compliance with the technical description by the item 3 of this annex and at test should be in compliance with the requirements determined in OIML R 49-1:2013 and EN ISO 4064-1:2017.

Metrological test is performed by testing equipment which should be in compliance with the requirements determined in EN ISO 4064-2:2017 and water at temperature $20^{\circ}\text{C} \pm 10^{\circ}\text{C}$ (for temperature class T30, T50) and $20^{\circ}\text{C} \pm 10^{\circ}\text{C}$ and $50^{\circ}\text{C} \pm 10^{\circ}\text{C}$ (for temperature class T70) at the following flowrates:

- a) Minimum flowrate $Q_1 \leq Q \leq 1,1Q_1$
- b) Transitional flowrate $Q_2 \leq Q \leq 1,1Q_2$
- c) Permanent flowrate $0,9Q_3 \leq Q \leq Q_3$

A metrological test may only be performed by a producer, or a notified body respectively in line with the conformity assessment procedure according to the Annex No. 2 (Module D or F) of the Governmental ordinance respectively.

9 Measures asked for providing measuring instrument integrity**9.1 Identification**

The ultrasonic water meter should be in compliance with the description provided in item 3 of this annex and should be in compliance with the marking specified on the item 7 of this annex. The number given to the EU-type examination certificate should be placed on each piece of the measuring instrument.

Emplacement of the conformity mark is determined by § 15 of the Governmental ordinance.

9.2 Sealing of the measuring instrument

The Ultrimis Neo meters are sealed by specially designed locking ring (1) and locking pins (2) (Picture No. 4) which prevents meter against fraud. The locking parts can be removed only with mechanical manipulation with visible signs of a tamper or destroying these parts. The locking ring is marked with safeguarding mark (POWOGAZ 3 KJ).

Water meter is equipped also with electronic seal mechanism - tamper detection - that shows any attempt of tamper on the LCD display and is not possible to remove from the memory.



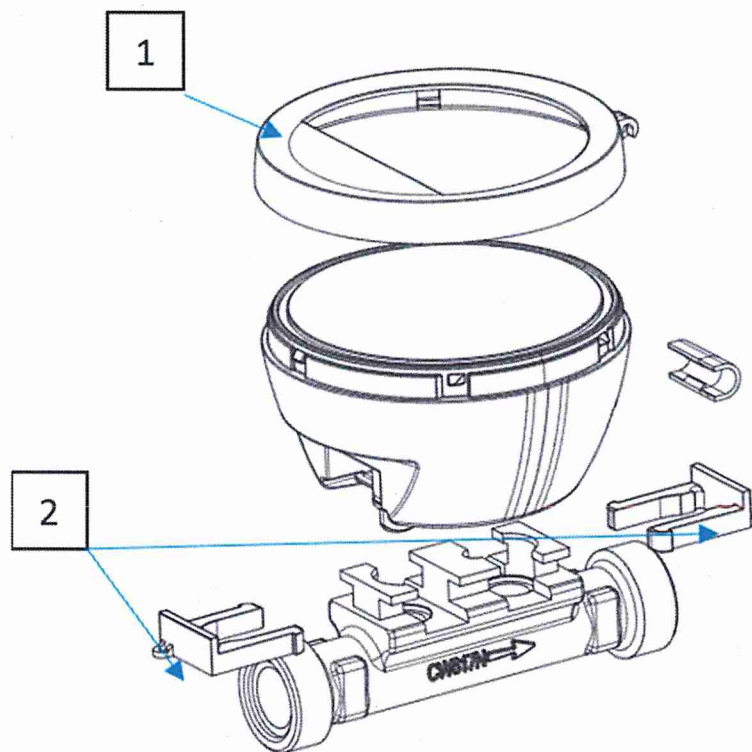

Picture No. 4 Ensuring the integrity of the instrument

9.3 Software security

The meter is physically sealed and cannot be accessed electronically without breaking the physical seal and triggering an electronic alarm. The chip is locked, so it is not possible to read out the software or alter a part of the software. There is no software update interface available. The adjustment and reading of metrological data are realized electronically using NFC communication protocol. The access to the metrological parameters is secured by multileveled passwords combination.

All legally relevant software is protected with a CRC-32. The CRC is recalculated and compared to the original every 24 hours. The CRC is shown in the display when there is no flow in the meter. The legally non-relevant Software is protected with CRC-32 as well. If an intentional or unintentional change happens in the legally relevant software, the meter will stop all measurements and show an error sign. If an intentional or unintentional change happens in the legally non-relevant software, then it will shut down. The legally relevant software will continue unhindered.



10 Requirements for installation, especially conditions of usage
10.1 Installation data

Nominal diameter	15		20		25
Marking	ULN1,6 ULN2,5	ULN1,6-01 ULN2,5-01	ULN2,5 ULN4	ULN2,5-01 ULN4-01	ULN6,3
Total length [mm]	80/ 110/ 115/ 165	80/ 110/ 115	105/ 115/ 130/ 190	105/ 130	165/ 260
Connection G	G3/4 G7/8 → G3/4		G1		G1 1/4
h [mm]	14/15 ⁽⁵⁾		17		21
Closed lid height H [mm]	75/76 ⁽³⁾		80		87
Opened lid height H1 [mm]	161/163 ⁽³⁾		167		174
Diameter D [mm]	92				
Weight [kg]	0,48 – 0,6	0,29 – 0,31	0,61 – 0,77	0,33 – 0,34	1,05 – 1,39

Nominal diameter	32	40	50	
Marking	ULN10	ULN16	ULN25	
Total length [mm]	260	300	200/ 270/ 300	
Connection G	G1 1/2	G2	G2 1/2	Flange
h [mm]	24	30	38	72
Closed lid height H [mm]	93	103	116	150
Opened lid height H1 [mm]	180	190	203	237
Diameter D [mm]	92			
Weight [kg]	1,68	2,15	2,48 – 3,14	6,29 – 6,95

⁵ applies to 7/8 → 3/4 thread size

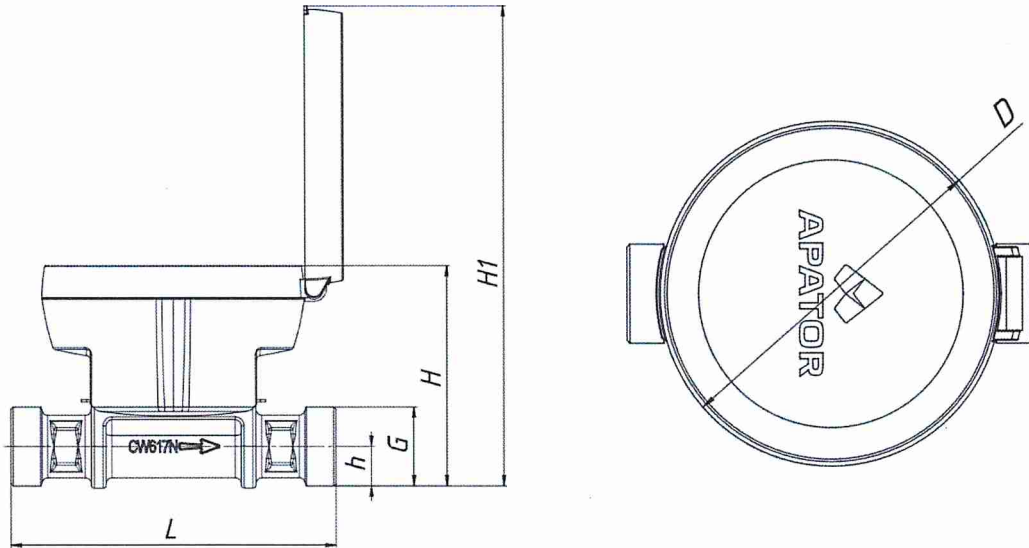

Picture No. 5 Installation dimensions

10.2 Installation requirements

The ultrasonic water meter should be introduced into the operation by a qualified for such activity worker with a certificate. Water meter is possible to put into use after a construction in line with this annex and in line with a manufacturer`s instruction “Instruction of installation and conditions of use of water meters”. A measuring instrument should be installed in direction of water flow arrow marked on the meter body.

10.3 Conditions of use

The measuring instrument should be used within the recommendations of a producer or manufacturer: “Instruction of installation and conditions of use of water meters”.

Assessment done by: Maryna Tokarieva



