

## APPENDIX A: Technical Specifications

---

### A.1 General

---

#### A.1.1 Intended Use

##### Clinical Applications

- Cardiology (including Transesophageal examinations)
- Peripheral Vascular
- Transcranial
- Abdominal
- Obstetrics and Gynecology
- Small parts
- Breast
- Musculoskeletal
- Fetal
- Transvaginal
- Transrectal
- Trauma
- Biopsy guided procedures
- Preventive Medicine
- Veterinary

#### A.1.2 Display Modes

##### Basic Imaging Modes

- B-mode (2D)
- Harmonic Imaging
- EzXScan (option)
- EzXtend View (option)
- EzHQView (option)
- M-mode, Anatomical M-mode (option)
- PW Doppler
- CW Doppler (option)
- Color Doppler (CFM) /Power Doppler /Velocity Directional Power Doppler
- Color M-mode
- Doppler Tissue Imaging (DTI) (option)
- Stress Echo (option)
- 4D (option)

##### Combined Modes

- B dual simple
- B dual synchronized
- B quad (all cine live)
- B + M, full M
- Duplex (B + PW/CW)
- Full PW
- Full CW
- CFM dual simple
- CFM dual synchronized
- CFM quad (all cine live)
- Triplex (B + CFM+ PW)

#### A.1.3 System Architecture

##### Architecture

- Digital beamformer
- Digital signal processing

- PC based, Multi-beam processing
- Modular concept
- Dedicated CW beamformer
- Import / export setting capability through CD-R/RW, DVD-R/RW and USB key

##### Probe Connectors

- 4 active electronic probe connectors
- 1 pencil probe connector

##### Keyboard

- Back lighted buttons, controls and alphanumeric keys
- PC-like mouse functions (trackball, right and left buttons)
- Minimum keystrokes for each operation
- Tiltable and swivelable
- Multi-language compatibility

##### Gain Controls

- Overall B/M: 0 to 31
- Doppler: 0 to 30 dB
- CFM: 0 to 20
- STC: 8 slider pots

##### Frame Rates

- > 300 fps in B-mode (transducer and application dependent)
- > 40 fps in CFM (depth, angle and clinical application dependent)

##### Grey and Color Shades

- 256 grey levels
- 256 color levels
- 16 color gamma maps for optimum rendering of echo structures

##### Video Display

- 22" active matrix LCD flat monitor
- 1024 x 768 pixels, XGA non interlaced
- Ultrasound image:
  - 824 x 555 pixels x 24 bits (small ultrasound display)
  - 1120 x 760 pixels x 24 bits (large ultrasound display)
- Tiltable and swivelable monitor
- Screen Information:
  - PC-like navigation
  - Hierarchical sub-menus for optimum workflow
  - Patient ID, facility name, date, time
  - Technical data field with all pertinent parameters
  - Measurement field displaying the last ten measurement results
  - Transmit / receive frequency indicator
  - Real time ECG trace display
  - Heart rate
  - Freeze indicator
  - Cine scrolling memory indicator
  - CFM ROI position and size
  - Image orientation indicator
  - Over 40 body markers
  - M-mode and Doppler mode cursors
  - Image thumbnails for archiving
  - Biopsy guide indicator (one or two lines for biopsy guidance)
  - Display of some information according to user preferences

## APPENDIX A: Technical Specifications

### Settings

- Application based presets for fast and easy image quality optimization
- User programmable settings

## A.2 Ultrasound Application

---

### A.2.1 B-mode (2D)

#### Image Format

- Depth: 2 to 36 cm (transducer dependent)
- Angle: 30° to 165° (transducer dependent)
- Trapezoidal Image
- Zoom 4 steps (live and freeze)
- Two different full B-mode display sizes

#### Signal Processing

- AFA (Automatic frequency Adjustment) (range dependent)
- Frequency bandwidth for signal processing: 1 to 18 MHz
- Dynamic focusing on pixel level
- High beam density: up to 384
- Multi-beam reception: up to 4
- Frequency Compounding
- Receiver gain control: 32 steps
- Time Gain Compensation: 8 slider pots
- Dynamic range: 54dB~96dB
- Tissue Harmonic Imaging
- Edge enhancement (the number of levels depends on both probe and medical application)
- Noise Rejection: (the number of levels depends on both probe and medical application)
- Frame filter: 8 non-linear smoothing filters
- One touch image optimization (E<sub>z</sub> Optim)
- E<sub>z</sub> XScan (Spatial Compounding): 8 levels with range dependent weighting and contrast enhancement
- E<sub>z</sub> HQView: 5 to 10 levels, application dedicated

#### Image Control

- Freeze / Unfreeze
- Left / Right
- Up / Down
- Two different full B-mode display sizes

### A.2.2 M-mode

#### Signal Processing

- As for B-mode

#### Display Parameters

- Sweep speed
- 2 to 10 sec / screen (full screen M-mode)
- 1 to 4 sec / screen (B + M-mode)
- Automatic M image updated when adjusting steering line position

#### Steering Line

- Trackball controlled over complete B sector
- Anatomical M-mode (User positioned on whole B sector)

### A.2.3 Spectral Doppler Modes

#### Supported Mode

- PW Doppler

- CW Doppler
- PW Doppler Tissue Imaging (DTI)

#### Signal Processing

- Frequencies: 1,7; 2; 2,5; 3; 4; 5; 7 MHz (transducer dependent)
- Wall filter: 50 to 1000 Hz
- 512 points FFT
- Spectral gain control: 11 positions from 0 to 30 dB (adjusted in both live and frozen modes)
- Doppler angle correction (adjusted in both live and frozen modes)
- Stereo audio for flow direction indication
- Adjustable audio volume
- Post-processing baseline shift and gain adjustment
- One touch Doppler optimization (EzOptim) (option)

#### Velocities

- PW:  $\pm 1$  kHz to  $\pm 24$  kHz
- CW:  $\pm 1$  kHz to  $\pm 48$  kHz
- Velocity range:  $\pm 5$  cm/s to  $\pm 9.02$  m/s (transducer and application dependent)

#### Display Parameters

- Duplex
- Baseline shift: 9 positions to avoid spectral aliasing, in live and freeze
- Sweep speed
  - 2 to 8 sec / screen (full screen spectrum)
  - 1 to 4 sec / screen (B / CFM + spectrum)
- Vmean and Vmax traces

#### Steering Line

- Trackball controlled over complete B sector
- Doppler gate size (PW): 1 to 15 mm, in 1 mm steps

### A.2.4 Color Doppler and Power Doppler Modes, Color M mode

#### Supported Mode

- Velocity mode
- Power Doppler Mode, Directional Power Doppler Mode (DPD) and Velocity Directional Power Doppler Mode (VDPD)
- Doppler Tissue Imaging (DTI)

#### Signal Processing

- Frequencies
- Wall filter
- Color gain control
- Color persistence
- Post-processing

#### Velocities

- Velocity range:  $\pm 1.4$  cm/s to  $\pm 4.51$  m/s (transducer and application dependent)

#### Display Parameters

- Triplex mode
- Baseline shift
- Turbulence on/off
- Color invert
- Sweep speed for Color M mode
  - 2 to 8 sec / screen (full screen spectrum)
  - 1 to 4 sec / screen (B / CFM + spectrum)

## A.2.5 ECG (option)

### Format

- ECG trace
- For all single and dual screen formats

### Image Trigger for ECG

- Single or dual trigger
- Independent trigger for dual mode

### Cine Scrolling Review

- Indication of time relationship between B image and ECG trace by marker on ECG trace

## A.3 Database, Measurements, Reporting

---

### A.3.1 Archiving and Communication

- Two internal Hard Disk Drives (HDD) (2 x 500GBytes)
- One internal Solid State Disk (SSD) (1 x 60GBytes)
- USB key import / export capability
- Cine memory (standard), long cine loop (option)
- Windows™ Network compatibility
- DICOM media storage (import and export)
- DICOM Storage SCU (option)
- DICOM Modality Worklist SCU (option)
- DICOM MPPS (option)

### Data Management and Archiving System (integrated PACS)

- Patient data management
- Off-line measurements
- Archiving:
  - Still images and cine loops
  - Acquired or imported data
- Reporting
- Format: bmp, jpeg, mpeg, pdf, html, DICOM 3.0
- Integrated Long Term Archiving and Backup function
- EzDesk (Stand-alone PACS and Reporting system running on a PC workstation)

### A.3.2 Measurements

- Measurement Packages for:
  - Cardiology, including:
    - iMAE: indexed Mitral Annulus Excursion
  - Vascular, including:
    - EzIMT: Automatic Intima-Media Thickness detection (option)
  - Abdominal
  - Ob/Gyn
  - Small parts
  - Breast
- Basic Measurements:
  - Distance
  - Area (Freehand or Spline line)
  - Circumference (Freehand or Spline line)
  - Volume 2 (Ellipsoid Volume)
  - Angle

- Volume (Simpson Volume for Cardiology only) (Freehand or Spline line)
- Time
- Slope
- Velocity, velocity profile
- Speed gradient
- Acceleration
- Integral, PI & RI, RI
- Vmean, Vmax
- Heart-rate

### A.3.3 Annotations

- Annotations list
  - System pre-defined
  - Allows user add-on
- Free Text
- Arrows
- Body markers (independent for dual mode)

### Measurement Accuracy

- Distance:  $< \pm 3\%$  or 1 mm
- Angle:  $< \pm 2.5^\circ$
- Time:  $< \pm 1\%$
- Slope:  $< \pm 4\%$
- Speed / velocity:  $< \pm 5\%$
- Gradient:  $< \pm 10\%$
- Acceleration:  $< \pm 10\%$
- Heart rate:  $\pm 1$  bpm

### A.3.4 Input/Output

- 2 USB ports 3.0 *SuperSpeed* (located at the Operation Panel)
- 2 USB ports (located at the rear panel)
- 2USB ports 3.0 *SuperSpeed* (located at the rear panel)
- 1 LAN port (Ethernet TX100/1000)
- Footswitch connector
- Display Port
- Audio Out & Microphone

## A.4 Environmental Conditions

---

### A.4.1 Electrical Specifications

- Power supply: 100-120/200-240V  $\pm 10\%$
- Main frequencies: 50 – 60 Hz
- Power consumption: max 550VA without peripherals
- Max 300 VA isolated AC output for peripherals

### A.4.2 Environment

#### In Operation

- Temperature: 10 to 40° C
- Humidity: 30 to 80% (non condensing)

#### In Storage

- Temperature: -10 to 60° C (system)
- Humidity: 10 to 90% (non condensing)

#### Electromagnetic Field

- Maximum field strength without degradation of perfor-

## APPENDIX A: Technical Specifications

pliance: 3 V/m

### A.4.3 Regulations and Safety

#### Regulations

- MDD (93/42/EEC)
- RoHS Directive (2011/65/EU)
- German K.V. regulation
- FDA 510(k)

#### Safety

- IEC 60601-1: 2005 Class I Type BF (electrical Safety)
- IEC 60601-1-2: 2007
- IEC 60601-1-6: 2010
- IEC 60601-2-37: 2007
- IEC 62304: 2006
- ISO 10993-1: 2009
- ISO 14971: 2007





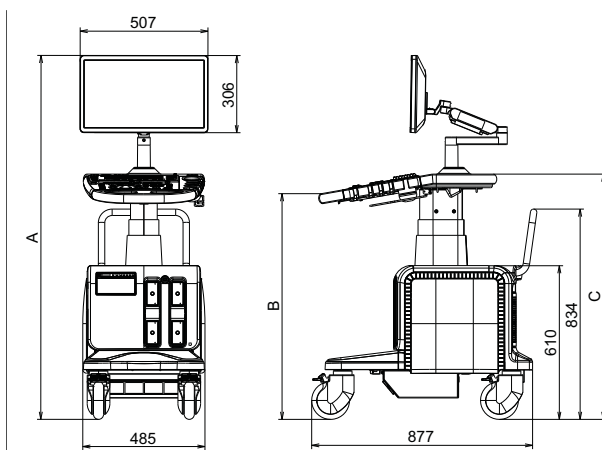

### A.4.4 Physical Dimension

- Weight: Approx. 85 kg (without peripherals)
- 510(W) x 880 (D) x 1280 -1580 (H) mm







- A: 1280 mm - 1580mm
- B: 745 mm - 945mm
- C: 830mm - 1030mm

A.5 Probes

		Frequency bandwidth	Scanning angle/width	Imaging modes	Biopsy	Applications
PHASED ARRAY	<b>SA16</b>  FUT-SA162-5P	2 - 5 MHz	45 to 90°	B/M/CFM/CM/PW/CW	✓	Adult and Paediatric Cardiology, Vascular, Transcranial; Abdominal
	<b>SA161</b>  FUT-SA161-5P	1 - 5 MHz	45 to 90°	B/M/CFM/CM/PW/CW	-	Adult and Paediatric Cardiology, Vascular, Transcranial; Abdominal
	<b>SG12</b>  FUT-SG125-8P	5 - 8 MHz	45 to 90°	B/M/CFM/CM/PW/CW	-	Neonatal Cardiology, Neonatal Cephalic, Abdominal
CONVEX	<b>CA 60</b>  FUT-CA602-5P	2 - 5 MHz	60° (60 mm ROC)	B/M/CFM/PW	✓	Abdominal, Vascular, Ob/Gyn
	<b>CVA 40</b>  FUT-CVA403-6P	3 - 6 MHz	60° (40 mm ROC)	B/M/CFM/PW/4D	-	Abdominal, Vascular, Ob/Gyn
MICRO-CONVEX	<b>CA14</b>  FUT-CA144-9P	4 - 9 MHz	90° (14 mm ROC)	B/M/CFM/PW	✓	Abdominal, Cardiac, Vascular
TRANS-VAGINAL	<b>TV 11</b>  FUT-TVG114-7P	3 - 8 MHz	30 to 165° (11 mm ROC)	B/M/CFM/PW	✓	Foetal, Transrectal, Transvaginal

A

## APPENDIX A: Technical Specifications

		Frequency bandwidth	Scanning angle/width	Imaging modes	Biopsy	Applications
<b>LINEAR</b>	<b>LA 40</b>  <i>FUT-LA403-8P</i>	3 - 8 MHz	40 mm	B/M/CFM/PW	-	Vascular, Small parts, Muskulo-skeletal
	<b>LA 38</b>  <i>FUT-LA385-12P</i>	5 - 12 MHz	38 mm	B/M/CFM/PW	✓	Vascular, Small parts, Muskulo-skeletal, Breast
	<b>LG 30</b>  <i>FUT-LG308-16A</i>	8 - 16 MHz	38 mm	B/M/CFM/PW	✓	Vascular, Small parts, Muskulo-skeletal
	<b>LA 25</b>  <i>FUT-LA255-12P</i>	5 - 12 MHz	25 mm	B/M/CFM/PW	-	Vascular, Small parts, Muskulo-skeletal