

Voluson™ Signature 18

Voluson™ Signature 20

Instructions For Use

English (English)



CE 0197

5926460-1EN

Revision 4

Software: SC400

© 2024 GE HealthCare

Revision History

Revision	Date
Revision 1	September 2022
Revision 2	February 2023
Revision 3	August 2023
Revision 4	January 2024

These Instructions for Use refer to the following Brand & Models:

Brand & Model	System
Voluson™ Signature 20	Voluson™ Signature 20
Voluson™ Signature 18	Voluson™ Signature 18

Table of Contents

Chapter 1 – Introduction

Manufacturer	1-4
About this system	1-5
Safety Conformance	1-8
Contacting GE HealthCare	1-9

Chapter 2 – Safety

Symbols and Labels	2-2
Information for safe use	2-11
Electric Installation	2-14
Environmental conditions for operation	2-15
Transport position	2-17
Moving the System	2-18
Operating position	2-20
Operation safety	2-21
Cleaning and disinfecting the system	2-24
Maintenance	2-32
Disposal	2-34
Bioeffects and Safety of Ultrasound Scans	2-35
Guidance and manufacturer’s declaration	2-39
Network Disclosure	2-43
Cybersecurity Note	2-45
Service Software – Remote Access	2-47
Software upgrade (eDelivery)	2-48
System Messages	2-49

Chapter 3 – System description

Overview	3-2
The system	3-3
The user interface	3-5
The monitor	3-13

Chapter 4 – Getting started

Powering the system	4-2
Getting started	4-5
Basic operations	4-8

Chapter 5 – Probes and Biopsies

Probe safety	5-2
Cleaning and maintenance of probes	5-5
Probes	5-22
Biopsies	5-25
Overview of all probes and biopsies	5-32

Chapter 6 – 2D Mode

2D Mode screen display	6-2
2D Mode standard features and modes	6-4
2D Mode options	6-24

Chapter 7 – Image management

SonoLyst	7-2
Scan Assistant	7-7

Image Annotation -----	7-11
Cine Mode -----	7-18
Chapter 8 – 3D and 4D Mode	
Visualization -----	8-3
General advice to obtain good rendered 3D/4D images -----	8-7
Initial Condition of different Probes -----	8-8
3D/4D Mode screen display -----	8-10
Volume Acquisition Modes -----	8-13
Volume Visualization Modes -----	8-22
Additional tools -----	8-37
Chapter 9 – Archive	
Open Archive -----	9-3
Data Transfer -----	9-8
Source -----	9-17
Patient ID -----	9-20
Clipboard -----	9-25
Chapter 10 – Measurements and Calculations	
Measurement Menu -----	10-3
Generic Measurements -----	10-7
Additional Measure Tools -----	10-18
Calculations -----	10-22
Worksheet/Report -----	10-30
Assessment Tools -----	10-44
Accuracies -----	10-47
Chapter 11 – System Setup	
System Setup -----	11-2
Chapter 12 – Peripheral Devices	
How to Connect Auxiliary Devices Safely -----	12-2
Peripherals and Hardware -----	12-5
Connection between Internal I/O and External I/O -----	12-8
USB Recorder (DVR) - Optional -----	12-11
ECG Preamplifier -----	12-14
Gel Warmer -----	12-17
Battery Pack -----	12-18
Vscan Air™ (Option) -----	12-23
Chapter 13 – Technical Data/ Information	
Safety conformance -----	13-2
Physical Attributes -----	13-4
System overview -----	13-6
Screen Formats -----	13-8
Display Modes -----	13-9
Display annotation -----	13-10
System Standard Features -----	13-14
System Options -----	13-16
System Parameters -----	13-18
Scanning Parameters -----	13-23
Generic Measurements and Measurements/Calculations -----	13-33
External Inputs and Outputs -----	13-40
Deep Learning Based Features -----	13-42

Chapter 14 – Glossary - Abbreviations

Chapter 1

Introduction

<i>Manufacturer</i>	1-4
<i>About this system</i>	1-5
<i>Safety Conformance</i>	1-8
<i>Contacting GE HealthCare</i>	1-9

Description of the system

The Voluson™ Signature 18 / Voluson™ Signature 20 system is a professional diagnostic Ultrasound System which transmits Ultrasound waves into body tissues and forms images from the information contained within the received echoes.

The Voluson™ Signature 18 / Voluson™ Signature 20 system Console and related Probes are an Active Diagnostic Medical Product belonging to Class IIa according to Medical Device Regulation (EU) 2017/745 for use on human patients.

The Voluson™ Signature 18 / Voluson™ Signature 20 system is developed and produced by GE ULTRASOUND KOREA, LTD..

Contacting the manufacturer

GE ULTRASOUND KOREA, LTD.

Address	9, Sunhwan-ro214beon-gil, Jungwon-gu, Seongnam-si, Gyeonggi-do, 13204 Republic of Korea
Telephone	+(82) 31-740-6112
Internet	http://www.gehealthcare.com

Diagnostic ultrasound

Dear valuable Customer,

We herewith would like to inform you that the American Institute of Ultrasound in Medicine (AIUM) advocates the responsible use of diagnostic ultrasound. The AIUM strongly discourages the non-medical use of ultrasound for psychosocial or entertainment purposes. The use of either two-dimensional (2D) or three-dimensional (3D) ultrasound to only view the fetus, obtain a picture of the fetus or determine the fetal gender without a medical indication is inappropriate and contrary to responsible medical practice.

Although the general use of ultrasound for medical diagnosis is considered safe, ultrasound energy has the potential to produce biological effects. Ultrasound bioeffects may result from scanning for a prolonged period, inappropriate use of color or pulsed Doppler ultrasound without a medical indication, or excessive thermal or mechanical index settings (American Institute of Ultrasound in Medicine: Keepsake Fetal Imaging; 2005). Thus ultrasound should be used in a prudent manner to provide medical benefit to the patient.



Authorized EU Representative

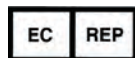

GE Medical Systems SCS
283 rue de la Minière
78530 BUC, France

Swiss Authorized Representative



GE Medical Systems (Schweiz) AG
Europa-Strasse 31, 8152 Glattbrugg, Switzerland

About these Instructions for Use

These Instructions for Use contain information on modes, features, probes and options available on the Voluson™ Signature 18 / Voluson™ Signature 20 system. Your individual configuration may vary depending on the product you have and the country you are in. Not all features may be available on

all Voluson™ Signature 18 / Voluson™ Signature 20 system systems. For more information see 'Overview options' on page 13-16.

- Read and understand all instructions in the Instructions for Use before attempting to use the Voluson™ Signature 18 / Voluson™ Signature 20 system.
- Keep these Instructions for Use with the product for future reference.
- The screen graphics and illustrations in these Instructions for Use are for illustrative purposes only and may be different from what is displayed on the screen or device.
- Some messages may not be displayed in some modes (i.e. fullscreen mode,...).
- Please note that the configuration of each system is based on the specific customer order and may not contain all features listed in these Instructions for Use.
- Some probes, options or features may not be available in some countries.
- Some features are only available on specific ultrasound consoles. Some scan modes are only available for specific ultrasound probes. Some features are only available for specific scan modes/applications and scan frequencies.
- All references to standards / regulations and their revisions are valid for the time of publication of these Instructions for Use.
- Paper Copy: The EU Commission Regulation on electronic instructions for use of medical devices in the European Union demands, that a paper copy of Instructions for Use can be ordered at no additional charge. You may therefore send a request to volusondocumentation-request@ge.com. This request will be treated within 7 days.

Service Manual

The Basic Service Manual referenced in this manual is part number 5926566. The latest version of the Service Manual is available at:

<https://www.gehealthcare.com/support/manuals>

Trademarks

GE is a trademark of General Electric Company used under trademark license.

1.1 Manufacturer



GE Ultrasound Korea, Ltd.

9, Sunhwan-ro 214beon-gil, Jungwon-gu, Seongnam-si, Gyeonggi-do, 13204

Republic of Korea

1.2 About this system

Intended use

This system is intended for ultrasound evaluation in the following clinical application: Image Acquisition for diagnostic purposes including measurements on acquired images. The device may be used by qualified physicians, sonographers, and healthcare professionals that are legally authorized or licensed by law in the country, state or other local municipality in which he or she practices. The users may or may not be working under supervision or authority of a physician.

Clinical applications include: Abdominal, Obstetrics, Gynecology, Cardiology, Transrectal, Peripheral vascular, Pediatrics, Cephalic, MSK, Breast and Small part.

Clinical Benefit

The clinical benefit of a diagnostic ultrasound device is to help healthcare professionals provide an accurate diagnostic information (visualize human tissue/internal structure) that enhances the diagnostic and treatment care pathways of the patient for a variety of diseases and conditions.

Clinical applications

- Abdomen
- Obstetrics
- Gynecology
- Cardiology
- Transrectal
- Peripheral Vascular
- Pediatrics
- Cephalic
- MSK
- Breast
- Small-parts

Patient population

- Age: all ages (incl. embryos and fetuses)
- Location: worldwide
- Sex: male and female
- Weight: all weight categories
- Height: no limitations

Operator profile

- Qualified physicians or sonographers or healthcare professionals with at least basic ultrasound knowledge.
- The operator must have read and understood the Instructions for Use.

Contraindications

The Voluson™ Signature 18 / Voluson™ Signature 20 system is not intended for:

- ophthalmic use or any use where the probe is directly applied to the eye.

- trans-oesophageal use
- transurethral use
- intra-operative use that is defined as introducing probe into a surgical incision or burr hole.
- intravascular use
- laparoscopic use

The feature **Shearwave Elastography** of the Voluson™ Signature 18 / Voluson™ Signature 20 system is not intended for:

- use on pregnant patients
- obstetric use

Essential performance of the ultrasound system

- Acquisition of ultrasound images
- Display of ultrasound images on main display
- Measurement on ultrasound images
- System must remain in a safe condition acc. IEC60601

Indications for Use Statement for US FDA

Voluson™ Signature 18 / Voluson™ Signature 20 system are a general-purpose diagnostic ultrasound system intended for use by a qualified and trained healthcare professional that are legally authorized or licensed by law in the country, state or other local municipality in which he or she practices for ultrasound imaging, measurement, display and analysis of the human body and fluid. The users may or may not be working under supervision or authority of a physician. Voluson™ Signature 18 / Voluson™ Signature 20 system clinical applications include: Fetal/Obstetrics; Abdominal (including Renal and Gynecology/ Pelvic); Pediatric; Small Organ (Breast, Testes, Thyroid, etc.); Neonatal Cephalic; Adult Cephalic; Cardiac (Adult and Pediatric); Peripheral Vascular (PV); Musculo-skeletal Conventional and Superficial; Transrectal (including Urology/Prostate) (TR); Transvaginal (TV).

Mode of operation include: B, M, AMM, PW Doppler, CW Doppler, Color Doppler, Color M Doppler, Power Doppler, Tissue Doppler, HD-Flow, Harmonic Imaging, Coded Pulse, 3D/4D Imaging mode, Elastography, Shearwave Elastography, B-Flow, Contrast and Combined modes: B/M, B/Color, B/PWD, B/Power/PWD. The Voluson™ Signature 18 / Voluson™ Signature 20 system are intended to be used in a hospital or medical clinic.

Regulatory remarks

- Federal law restricts this device to sale by or on the order of a physician or other legally authorized or licensed healthcare professional.
- This machine must be used in compliance with the law. Some jurisdictions restrict certain uses such as gender determination, contrast imaging, IVF, PUBS or CVS, etc. Please consider the local laws and regulations.
- The equipment conforms with regulations for electrical safety IEC 60601 and safety class IIa according to the Medical Device Regulation (EU) 2017/745 for use on human patients.
- Reporting: In case of a serious incident occurred in relation to Voluson™ Signature 18 / Voluson™ Signature 20 system ultrasound products, the incident should be reported to both the manufacturer and the health authority/competent authority where the device is installed.

To report to GE Healthcare:

- Either contact your local service representative Or report to:
In-box.complaints@ge.com
- Please provide the following information:
 - The catalogue number or the model designation of the device as stated on its identification plate affixed on the device
 - The SystemID / serial number / lot number of the device
 - Date of incident
 - Description of incident, including any patient or user impact / injury
 - Your contact information (facility, address, contact name, title and telephone number)

The manufacturer, assembler, importer or installer consider themselves responsible regarding safety, reliability and performance of the equipment under the following conditions:

- Authorized personnel has performed installation and initial start-up of the system.
- Options or new settings have only been added by authorized personnel.
- Authorized personnel has performed modifications or repairs.
- The local electric installation complies with the national regulations.
- The equipment is only used according to the Instructions for Use.

Cybersecurity Bill of Materials (CBOM)

Cybersecurity Bill of Materials (CBOM) – a list that includes but is not limited to commercial, open source, and off-the-shelf software and hardware components that are or could become susceptible to vulnerabilities.

Since the CBOM is linked to specific software releases for the Voluson™ Signature 18 / Voluson™ Signature 20 system, the CBOM is integrated into the system software and can be displayed as follows:

1. Open the **System Setup**
2. Select **Administration** and move on to the tab **System Info**.
3. The CBOM is displayed in the **System Info: Software** area.

Importer Information for Turkey

- Türkiye İthalatçısı
GE Medical Systems Türkiye Ltd. Şti.
Esentepe Mah. Harman Sok. No: 8
34394 Şişli İstanbul Türkiye

Kazakhstan - Authorized representative in Kazakhstan

This information is only valid for Kazakhstan.

English	Kazakh	Russian
GE HealthCare Kazakhstan LLP 26/41, Zenkova Street, Medeu, District, Almaty, 050010 Kazakhstan T +7 727 3560020	«ДжиИ Хэлскеа Қазақстан» ЖШС Қазақстан, Алматы қаласы, Медеу ауданы, көшесі ЗЕНКОВ, үй 26/41, пошталық индексі 050010 T +7 727 3560020	ТОО «ДжиИ Хэлскеа Казахстан» Казахстан, город Алматы, Медеуский район, улица Зенкова, дом 26/41, почтовый индекс 050010 T +7 727 3560020

1.3 Safety Conformance

The Voluson™ Signature 18 / Voluson™ Signature 20 conforms to the following standards and regulations :

- Classified to ANSI/AAMI ES60601-1 Medical Electrical Equipment, Part 1: General Requirements for Safety by a Nationally Recognized Test Lab
- Certified to CSA CAN/ CSA-C22.2 NO. 60601-1 General requirements for safety
- Conforms to the following standards for safety:
 - IEC/ EN 60601-1 Medical electrical equipment - Part1 : General requirements for safety
 - EMC Emissions Group 1. Class A device requirements as per Sub clause 5.3 of CISPR 11
 - IEC/ EN 60601-1-6 Medical electrical equipment - Part 1-6: General requirements for basic safety and essential performance - Collateral Standard: Usability
 - IEC/ EN 60601-2-37 Medical electrical equipment - Part 2-37: Particular requirements for the safety of ultrasonic medical diagnostic and monitoring equipment
 - IEC/EN 62366-1 Medical devices-Part1: Application of usability engineering to medical devices
 - IEC/EN 62304 Software Life Cycle Processes
 - IEC/EN 62359 Ultrasonic - Field characterization - Test methods for the determination of thermal and mechanical indices related to medical diagnostic ultrasonic fields.
 - EN/ISO15223-1 Medical devices - Symbols to be used with medical device labels, labelling and information to be supplied - Part 1: General requirements
 - ISO 10993-1 Biological evaluation of medical devices - Part 1 Evaluation and testing
 - WEEE (Waste Electrical and Electronic Equipment)
 - ROHS according to 2011/65/EU
 - IEC/EN 60601-1-2 Medical electrical equipment - Part 1-2: General requirements for basic safety and essential performance - Collateral Standard: Electromagnetic disturbances - Requirements and tests

1.4 Contacting GE HealthCare

For additional information or assistance, please contact your local distributor or the appropriate support resource listed on the following pages:

INTERNET	http://www.gehealthcare.com http://www.gehealthcare.com/transducers
Clinical Questions	<p>For information in the United States, Canada, Mexico and parts of the Caribbean, call the Customer Answer Center Phone: (1) 800-682-5327 or (1) 262-524-5698</p> <p>In other locations, contact your local Applications, Sales or Service Representative.</p>
Service Questions	<p>For service in the United States, call GE CARES Phone: (1) 800-437-1171</p> <p>For service for compact products in the United States, call Phone: (1) 877-800-6776</p> <p>In other locations, contact your local Service Representative.</p>
Information Request	<p>To request the latest GE Accessories catalog or equipment brochures in the United States, call the Response Center</p> <p>Phone: (1) 800-643-6439</p> <p>In other locations, contact your local Applications, Sales or Service Representative.</p>
Placing an Order	<p>To order accessories, supplies or service parts in the United States, call the GE Healthcare Technologies Contact Center</p> <p>Phone: (1) 800-558-5102</p> <p>In other locations, contact your local Applications, Sales or Service Representative.</p>
ARGENTINA	<p>GEME S.A.</p> <p>Miranda 5237</p> <p>Buenos Aires - 1407</p> <p>Phone: (1) 639-1619</p> <p>Fax: (1) 567-2678</p>
ASIA PACIFIC JAPAN	<p>GE Healthcare Asia Pacific</p> <p>4-7-127, Asahigaoka</p> <p>Hino-shi, Tokyo</p> <p>191-8503 Japan</p> <p>Tel: +81 42 585 5111</p>
AUSTRALIA NEW ZEALAND	<p>GE Healthcare Australia & New Zealand</p> <p>32 Phillip Street</p> <p>Parramatta NSW 2150</p> <p>Australia</p> <p>Tel: +61 2 9846 4000</p> <p>8 Tangihua Street</p> <p>Auckland 1010</p> <p>New Zealand</p> <p>Tel: 0800 434 325</p>
AUSTRIA	<p>General Electric Austria GmbH</p> <p>Filiale GE Healthcare Technologies EURO PLAZA, Gebäude E</p> <p>Wienerbergstrasse 41</p> <p>A-1120 Vienna</p> <p>Phone: (+43) 1 97272 0</p> <p>Fax: (+43) 1 97272 2222</p>

BELGIUM & LUXENMBURG	GE Medical Systems Ultrasound Eagle Building Kouterveldstraat 20 1831 DIEGEM Phone: (+32) 2 719 7204 Fax: (+32) 2 719 7205
BRAZIL	Av. Magalhães de Castro 4800, Andar 10 Conj. 101 e 102, Torre 3 - Cidade Jardim, São Paulo/SP - Brasil CEP: 05676-120
CANADA	GE Healthcare Ultrasound Service Engineering 9900 Innovation Drive Wauwatosa, WI 53226 Phone: (1) 800 668-0732 Customer Answer Center Phone: (1) 262-524-5698
CHINA	GE Healthcare - Asia No. 1, Yongchang North Road Beijing Economic & Technology Development Area Beijing 100176, China Phone: (8610) 5806 8888 Fax: (8610) 6787 1162
CZECH REPUBLIC	GE Medical Systems Ultrasound Vyskocilova 1422/1a 140 28 Praha
DENMARK	GE Medical Systems Ultrasound Park Alle 295 2605 Brøndby Phone: (+45) 43 295 400 Fax: (+45) 43 295 399
ESTONIA & FINLAND	GE Medical Systems Kuortaneenkatu 2, 000510 Helsinki P.O.Box 330, 00031 GE Finland Phone: (+358) 10 39 48 220 Fax: (+358) 10 39 48 221
FRANCE	GE Medical Systems Ultrasound and Primary Care Diagnostics F-78457 Velizy Fax: (+33) 13 44 95 202 General Imaging: Phone: (+33) 13 449 52 43 Cardiology: Phone: (+33) 13 449 52 31
GERMANY	GE Healthcare GmbH Beethovenstrasse 239 42655 Solingen Phone: (+49) 212-28 02-0 Fax: (+49) 212-28 02 28

GREECE	GE Healthcare 8-10 Sorou Str. Marousi Athens 15125 Hellas Phone: (+30) 210 8930600 Fax: (+30) 210 9625931
HUNGARY	GE Hungary Zrt. Ultrasound Division Akron u. 2 Budaors 2040 Hungary Phone: (+36) 23 410 314 Fax: (+36) 23 410 390
INDIA	Wipro GE Healthcare Pvt Ltd No. 4, Kadugodi Industrial Area Bangalore, 560067 Phone: +(91) 1-800-425-8025
ITALY	GE Medical Systems Italia spa Via Galeno, 36 20126 Milano Phone: (+39) 02 2600 1111 Fax: (+39) 02 2600 1599
KOREA	Seoul, Korea Phone: (+82) 2 6201 3114
LUXEMBOURG	Phone: 0800 2603 toll free
MEXICO	GE Sistemas Medicos de Mexico S.A. de C.V. Rio Lerma #302, 1º y 2º Pisos Colonia Cuauhtemoc 06500-Mexico, D.F. Phone: (5) 228-9600 Fax: (5) 211-4631
NETHERLANDS	GE Healthcare De Wel 18 B, 3871 MV Hoevelaken PO Box 22, 3870 CA Hoevelaken Phone: (+31) 33 254 1290 Fax: (+31) 33 254 1292
NORTHERN IRELAND	GE Healthcare Victoria Business Park 9, Westbank Road, Belfast BT3 9JL Phone: (+44) 28 90229900
NORWAY	GE Medical Systems Ultrasound Tåsenveien 71, 0873 Oslo Phone: (+47) 23 18 50 50 Strandpromenaden 45, P.O. Box 141, 3191 Horten Phone: (+47) 33 02 11 16
POLAND	GE Medical Systems Polska Sp. z o.o., ul. Wotoska 9 02-583 Warszawa, Poland Phone: (+48) 22 330 83 00 Fax: (+48) 22 330 83 83

PORTUGAL	General Electric Portuguesa SA. Avenida do Forte, n° 4 Fraccão F, 2795-502 Carnaxide Phone: (+351) 21 425 1309 Fax: (+351) 21 425 1343
REPUBLIC OF IRELAND	GE Healthcare Unit F4, Centrepont Business Park Oak Drive, Dublin 22 Phone: (+353) 1 4605500
RUSSIA	LLC GE Healthcare Presnenskaya nab., 10 123112 Moscow, Russian Federation Service center tel: 8 800 333 6967 Office Phone: (+7) 495 739 6931 Office Fax:(+7) 4957 396932
SINGAPORE	GE Healthcare Singapore 1 Maritime Square #13-012 HarbourFront Centre Singapore 099253 Tel: +65 6291 8528
SPAIN	GE Healthcare Espana C/ Gobelos 35-37 28023 Madrid Phone: (+34) 91 663 2500 Fax: (+34) 91 663 2501
SWEDEN	GE Medical Systems Ultrasound PO Box 314 17175 Stockholm Phone: (+46) 8 559 50010
SWITZERLAND	GE Medical Systems Ab Europastrasse 31 8152 Glattbrugg Phone: (+41) 1 809 92 92 Fax: (+41) 1 809 92 22
TURKEY	GE Healthcare Türkiye Istanbul Office TEL: +90 212 398 07 00 FAKS: +90 212 284 67 00 Esentepe Mah. Harman Sok. 34394 No:8 Sisli-Istanbul
UKRAINE	Authorized Representative in Ukraine GE Ukraine LLC Mikhailovsky Str., 7, Kyiv, 01001, Ukraine Tel. +380443630350
United Arab Emirates (U.A.E.)	GE Healthcare Holding Dubai Internet City, Building No. 18 P.O. Box #11549, Dubai U.A.E. Phone: +971 4 4296161 Phone: +971 4 4296101 Fax: +971 4 4296201

UNITED KINGDOM	GE Medical Systems Ultrasound 71 Great North Road Hatfield, Hertfordshire, AL9 5EN Phone: (+44) 1707 263570 Fax: (+44) 1707 260065
USA	GE Healthcare Ultrasound Service Engineering 9900 Innovation Drive Wauwatosa, WI 53226 Phone: (1) 800-437-1171 Fax: (1) 414-721-3865

This page was intentionally left blank.

Chapter 2







Safety



<i>Symbols and Labels</i>	2-2
<i>Information for safe use</i>	2-11
<i>Electric Installation</i>	2-14
<i>Environmental conditions for operation</i>	2-15
<i>Transport position</i>	2-17
<i>Moving the System</i>	2-18
<i>Operating position</i>	2-20
<i>Operation safety</i>	2-21
<i>Cleaning and disinfecting the system</i>	2-24
<i>Maintenance</i>	2-32
<i>Disposal</i>	2-34
<i>Bioeffects and Safety of Ultrasound Scans</i>	2-35
<i>Guidance and manufacturer 's declaration</i>	2-39
<i>Network Disclosure</i>	2-43
<i>Cybersecurity Note</i>	2-45
<i>Service Software – Remote Access</i>	2-47
<i>Software upgrade (eDelivery)</i>	2-48
<i>System Messages</i>	2-49

2.1 Symbols and Labels

Description of all symbols and labels used on the system and in the Instructions for Use.









2.1.1 Warning labels used in the Instructions for Use















Symbol	Meaning	Reference
	Warning Indicates a hazard with a medium level of risk which, if not avoided, could result in death or serious injury.	IEC 60601-1; ISO 7010-W001
	Caution Indicates a hazard with a low level of risk which, if not avoided, could result in minor or moderate injury.	General caution sign; IEC 60601-1; ISO 7000-0434A
	Caution/Warning: Electric Hazard Indicates the risk of injury from electric hazards.	General caution/warning sign, adapted to indicate electrical hazards IEC 60601-1; ISO 3864-1,
	Caution: Biological Hazard Indicates the risk of disease transmission or infections.	General caution sign, adapted to indicate biological hazards IEC 60601-1; ISO 3864-1,
	Caution/Warning: Explosion Hazard Indicates the risk of injury from explosion hazards.	General caution/warning sign, adapted to indicate explosion hazards IEC 60601-1; ISO 3864-1
	Caution: Moving Hazard Indicates the risk of injury from moving or tipping hazards.	General caution sign, adapted to indicate moving or tipping hazards IEC 60601-1; ISO 3864-1,
	Caution: Mechanical Hazard Indicates the risk of injury from mechanical hazards.	General caution sign, adapted to indicate mechanical hazards IEC 60601-1; ISO 3864-1,









Symbol	Meaning	Reference
	Caution: Non-ionizing Hazard Indicates the risk of injury from non-ionizing radiation.	General caution sign, adapted to indicate non-ionizing radiation hazards IEC 60601-1; ISO 3864-1,
	Caution: hot surface Indicates that the marked item can be hot and should not be touched without taking care.	1. The inner symbol is standardized in ISO 7000-0535 "Transfer of heat, general" 2. Caution signs are standardized in ISO 3864.
	Pinch Point - Keep away fingers, hand, ... from the mechanics of the braking gear..	GE HealthCare crafted symbol based on IEC 60601-1 and ISO 3864-1

2.1.2 Description of symbols and labels

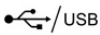
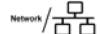

Some symbols used with electrical medical equipment have been accepted as standard by IEC. They serve for marking connections, accessories, and as warnings.









Symbol	Meaning	Reference
	Main power switch ON	IEC 60601-1; IEC 60417-5007
	Main power switch OFF	IEC 60601-1; IEC 60417-5008
	USB3.0	USB 3.0 standard
	Standby button; Stand-by	IEC 60601-1; IEC 60417-5009
	Insulated patient applied part (Type BF)	IEC 60601-1; IEC 60417-5333
	Do not use the following devices near this equipment: cellular phone, radio receiver, mobile radio transmitter, radio controlled toy, broadband power lines, etc. Use of these devices near this equipment could cause this equipment to perform outside the published specifications. Keep power to these devices turned off when near this equipment.	ISO 7010-P013
	ECG symbol	GE HealthCare crafted symbol
	Defibrillation-proof insulated patient applied part (Type CF)	IEC 60601-1:2005+A1:2012 Annex D.1 and IEC 60417-5336



Symbol	Meaning	Reference
	Insulated patient applied part (Type CF)	IEC 60601-1; IEC 60417-5333
	Potential equilibrium connection	IEC 60601-1; IEC 60417-5021
	This symbol is followed by the manufacturing date of the device in the form YYYY-MM	ISO 15223-1
	This symbol is followed by the name and address of the manufacturer of the device.	ISO 15223-1
P/N	Refers to the Part number of the system.	GE HealthCare crafted symbol
	This symbol is followed by the serial number of the device.	ISO 15223-1
	Batch or lot number	ISO 15223-1
	Brand and model (reference number)	ISO 15223-1
	This symbol indicates that the waste of electrical and electronic equipment must not be disposed as unsorted municipal waste and must be collected separately. Please contact the manufacturer or other authorized disposal company to decommission your equipment according to local regulations. 'Disposal ' on page 2-34	2012/19/EU (WEEE)
	Pictogram on Probe Care Card: Use care when handling ultrasound probes and protect the probe head from damage.	GE HealthCare crafted symbol
	Pictogram on Probe Care Card: Do not immerse the probe into any liquid beyond the level specified for that probe. Refer to the Instructions for Use of the ultrasound system.	GE HealthCare crafted symbol
	Pictogram on Probe Care Card: Describes precautions necessary to prevent the risk of disease transmission or infections.	ISO 15223-1
	Pictogram on Probe Care Card: Describes precautions necessary to prevent the risk of injury through electric hazards. Warning, electricity	IEC 60601-1; ISO 7010-W012
	NRTL Classification Label	TUV crafted symbol
	CE Conformity mark according to Medical Device Regulation (EU) 2017/745	Regulation (EU) 2017/745

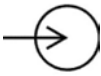
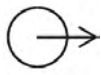

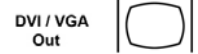

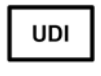



Symbol	Meaning	Reference
	Consult accompanying documents. This symbol advises the user to consult the accompanying documents.	IEC 60601-1; ISO 7010-M002
Green dot on power cable plug	Indicates that the power cable is hospital grade. Grounding reliability can only be achieved when the equipment is connected to an equivalent receptacle marked "Hospital only" or "Hospital grade". Applicable depending on local regulatory requirements.	ANSI/UL 498 and CSA CAN/C22.2 No. 42-99
650VA	This indicates the maximum rated power consumption of the system.	GE HealthCare crafted symbol
	Caution, consult accompanying documents. This symbol advises the reader to consult the accompanying documents for important safety-related information such as warnings and pre-cautions that cannot be presented on the device itself.	IEC 60601-1; ISO 7000-0434A; ISO 15223-1:
IPX0	No protection against ingress of water (system)	IEC 60529
IPX7 IPX8 IP67 IP44	Degrees of protection provided by enclosures (IP Code)	IEC 60529
 /USB	Indicates a USB connector.	GE HealthCare crafted symbol
 /Network	Indicates a network connector. Computer network.	IEC 60417
	Earth (ground) connection	IEC 60601-1:IEC60417-5007
	Product was refurbished / remanufactured by GE ULTRASOUND KOREA, LTD.	GE HealthCare crafted symbol
	This symbol indicates ESD (electrostatic discharge) sensitivity of a connector that is not tested as specified in IEC 60601-1-2. Electrostatic discharge can damage the product. Do not touch exposed connector pins.	IEC 60601-1-2; IEC 60417
	This symbol indicates the name and address of authorized representative in the European Community.	ISO 15223-1
	Swiss authorized representative(CH-REP) This symbol indicates the name and address of authorized representative registered place of business	Swissmedic
Rx Only	This symbol indicates that in the United States of America, federal law restricts this device to sale by or on the order of a physician.	FDA 21 CFR 801



Symbol	Meaning	Reference
	The patient cable protects against the effects of the discharge of a cardiac defibrillator. Use the patient cables as described in the chapter 'ECG Preamplifier' on page 12-14.	IEC 60601-1:2005+A1:2012 Annex D and ISO 7010-W001
Assembled in <Country Name>	Assembled in <Country Name> - Country may vary.	N/A







 	<p>This symbol indicates the product contains hazardous materials in excess of the limits established by the Chinese standard SJ/ T11364-2014 Requirements of concentration limits for certain restricted substances in electrical and electronic products.</p> <p>The number in the symbol is the Environment-friendly Use Period (EFUP), which indicates the period during which the hazardous substances contained in electrical and electronic products will not leak or mutate under normal operating conditions so that the use of such electrical and electronic products will not result in any severe environmental pollution, any bodily injury or damage to any assets. The unit of the period is “Year”.</p> <p>In order to maintain the declared EFUP, the product shall be operated normally according to the instructions and environmental conditions as defined in the product Instructions for Use, and periodic maintenance schedules specified in Product Maintenance Procedures shall be followed strictly.</p> <p>Consumables or certain parts may have their own label with an EFUP value less than the product. Periodic replacement of those consumables or parts to maintain the declared EFUP shall be done in accordance with the Product Maintenance Procedures. This product must not be disposed of as unsorted municipal waste, and must be collected separately and handled properly after decommissioning. (Reference : China Electronic Industry Standard SJ/T11364-2014)</p> <table border="1" style="width: 100%; border-collapse: collapse;"> <thead> <tr> <th rowspan="2">Component Name</th> <th colspan="6">Hazardous Substances' Name</th> </tr> <tr> <th>(Pb)</th> <th>(Hg)</th> <th>(Cd)</th> <th>(Cr(VI))</th> <th>(PBB)</th> <th>(PBDE)</th> </tr> </thead> <tbody> <tr> <td>Ultrasound Probes</td> <td>X</td> <td>O</td> <td>O</td> <td>O</td> <td>O</td> <td>O</td> </tr> <tr> <td>LCD Monitor</td> <td>X</td> <td>O</td> <td>O</td> <td>O</td> <td>O</td> <td>O</td> </tr> <tr> <td>Operator Panel</td> <td>X</td> <td>O</td> <td>O</td> <td>O</td> <td>O</td> <td>O</td> </tr> <tr> <td>PWAs</td> <td>X</td> <td>O</td> <td>O</td> <td>O</td> <td>O</td> <td>O</td> </tr> <tr> <td>Cables</td> <td>X</td> <td>O</td> <td>O</td> <td>O</td> <td>O</td> <td>O</td> </tr> <tr> <td>Power assembly</td> <td>X</td> <td>O</td> <td>O</td> <td>O</td> <td>O</td> <td>O</td> </tr> <tr> <td>System Covers</td> <td>X</td> <td>O</td> <td>O</td> <td>O</td> <td>O</td> <td>O</td> </tr> <tr> <td>Frame Assembly</td> <td>O</td> <td>O</td> <td>O</td> <td>O</td> <td>O</td> <td>O</td> </tr> <tr> <td>Rubber</td> <td>O</td> <td>O</td> <td>O</td> <td>O</td> <td>O</td> <td>O</td> </tr> </tbody> </table> <p>This table is prepared according to SJ/T 11364.</p> <p>O: Indicates that hazardous substance contained in all of the homogeneous materials for this part is below the limit requirement in GB/T 26572.</p> <p>X: Indicates that hazardous substance contained in at least one of the homogeneous materials used for this part is above the limit requirement in GB/T 26572 .</p> <ul style="list-style-type: none"> • Data listed in the table represents best information available at the time of publication • Applications of hazardous substances in this medical device are required to achieve its intended clinical uses, and/or to provide better protection to human beings and/or to environment, due to lack of reasonably (economically or technically) available substitutes. 	Component Name	Hazardous Substances' Name						(Pb)	(Hg)	(Cd)	(Cr(VI))	(PBB)	(PBDE)	Ultrasound Probes	X	O	O	O	O	O	LCD Monitor	X	O	O	O	O	O	Operator Panel	X	O	O	O	O	O	PWAs	X	O	O	O	O	O	Cables	X	O	O	O	O	O	Power assembly	X	O	O	O	O	O	System Covers	X	O	O	O	O	O	Frame Assembly	O	O	O	O	O	O	Rubber	O	O	O	O	O	O
Component Name	Hazardous Substances' Name																																																																												
	(Pb)	(Hg)	(Cd)	(Cr(VI))	(PBB)	(PBDE)																																																																							
Ultrasound Probes	X	O	O	O	O	O																																																																							
LCD Monitor	X	O	O	O	O	O																																																																							
Operator Panel	X	O	O	O	O	O																																																																							
PWAs	X	O	O	O	O	O																																																																							
Cables	X	O	O	O	O	O																																																																							
Power assembly	X	O	O	O	O	O																																																																							
System Covers	X	O	O	O	O	O																																																																							
Frame Assembly	O	O	O	O	O	O																																																																							
Rubber	O	O	O	O	O	O																																																																							

Symbol	Meaning	Reference
	Tipping danger. Do not lean on the system and take special care when moving the system. For transport (especially on inclines >5°) always observe the instructions described in 'Moving the System' on page 2-18.	IEC 60601-1; ISO 7010-P017
	This precaution is intended to prevent injury that may result if one person attempt to move the system considerable distances or on an incline due to the weight of the system.	GE HealthCare crafted symbol
	Maximum load 1kg- Danger of breaking. Do not put any items exceeding the indicated maximum load limit on this shelf.	Location: On the control panel rear tray
100 - 240 V~	Indicates the voltage range the device is built for. The device uses alternating current.	GE HealthCare crafted symbol
50/60Hz	This indicates the electrical frequency that the device is built for. Please note that either the first frequency OR the second frequency is applicable – depending on your country's frequency.	GE HealthCare crafted symbol
93kg	This indicates the approximate weight of the system including its safe working load in kilograms.	GE HealthCare crafted symbol
	Dangerous electric voltage.	IEC 60601-1; IEC 60417-5036
	Indicates a connector that allows for input only.	IEC TR 60878-5034, IEC60417-5034
	Indicates a connector that allows for in- and output.	IEC TR 60878-5035, IEC60417-5035
	Connect the monitor cable to this connector (One cable used for power, one cable used for signal).	IEC 60417
	Indicates a DVI/VGA output connector.	IEC 60417
	Indicates an S-Video output connector.	GE HealthCare crafted symbol
	Pinch point Watch your hands and fingers when adjusting the monitor. Keep hands clear of openings.	GE HealthCare crafted symbol based on IEC 60601-1; ISO 7010-P001 and ISO 3864-1,
	Every system has a unique marking for identification, the Unique Device Identification (UDI) Label. The UDI label consists of a series of alpha-numeric characters and barcode which uniquely identify the Voluson™ series system as a medical device manufactured by 2024 GE HealthCare. The UDI marking is part of the product labeling which can be found at the back of the ultrasound system. Scan or enter the UDI information into the patient health record as required by country-specific laws.	FDA 21 CFR 830 ISO 15223-1

Symbol	Meaning	Reference
	Electronic instructions for use To indicate on product or product packaging that relevant information for use of the product is available in electronic form rather than, or in addition to, printed paper form.	ISO 7000-3500
	This symbol indicates that the device is a Medical Device	ISO 15223-1
	This symbol indicates suitable modes/settings for lung examination.	GE HealthCare crafted symbol

Symbol	Meaning	Reference
	Use No Hooks To indicate that hooks shall not be used for handling the transport package.	ISO7000-0622
	This way up To indicate correct upright position of the transport package.	ISO7000-0623
	Fragile, handle with care Indicate a medical device that can be broken or damaged if not handle carefully	ISO15223-1:5.3.1 ISO7000-0621
	Do not stack To indicate that the items shall not be vertically stacked beyond the specified number, either because of the nature of the transport packaging or because of the nature of the items themselves.	ISO7000-2004
	Keep dry Indicates a medical device that needs to be protected from moisture.	ISO15223-1:5.3.4 ISO7000-0626
	Temperature limitation Indicates the temperature limits to which the medical device can be safely exposed.	ISO15223-1:5.3.7 ISO7000-0632
	Humidity limitation Indicates the range of humidity to which the medical device can be safely exposed.	ISO15223-1:5.3.8 ISO7000-2620
	Atmospheric pressure limitation Indicates the range of atmospheric pressure to which the medical device can be safely exposed.	ISO15223-1:5.3.9 ISO7000-2621
	MR Unsafe An item marked MR unsafe is known to pose hazards in all MRI environments. The Voluson™ Signature 18 / Voluson™ Signature 20 are MR unsafe.	ASTM F2503

Symbol	Meaning	Reference
	Symbol that is shown on the screen (monitor and/ or touch-display) that indicates a temporary data-interruption (cine gap). The duration of the cine gap is displayed in seconds below the symbol.	GE HealthCare crafted symbol
	This symbol indicates suitable modes/settings for ophthalmic artery examination, where the probe is applied onto the closed eyelid.	GE HealthCare crafted symbol

Symbol	Meaning	Reference
	Gel Pictogram: This is to illustrate compatible ultrasound coupling gels	GE HealthCare crafted symbol
	Spray Pictogram: This is to illustrate compatible cleaners or disinfectants available in spray format (to be used according to instruction from the manufacturers of these products)	GE HealthCare crafted symbol
	Wipes Pictogram: This is to illustrate compatible cleaners or disinfectants available in wipes format (to be used according to instruction from the manufacturers of these products)	GE HealthCare crafted symbol
	Powder Pictogram: This is to illustrate compatible cleaners or disinfectants available in powder (to be used according to instruction from the manufacturers of these products)	GE HealthCare crafted symbol
	Liquid Pictogram: This is to illustrate compatible cleaners or disinfectants available in liquid format (to be used according to instruction from the manufacturers of these products)	GE HealthCare crafted symbol
	Automatic disinfection Pictogram: This is to illustrate compatible automated reprocessors (to be used according to instruction from the manufacturers of these products)	GE HealthCare crafted symbol

Label on the packing box



Figure 2-1 Label on the packing box

This label is printed on the packing box of the system to indicate the humidity, temperature and air pressure condition for the storage and shipment.

2.2 Information for safe use

Please be advised that the electronic version of the Instructions for Use/addenda internally displayed is provided for additional information purpose only. As official reference always consult the printed document with the highest revision or the Instructions for Use/addenda provided on the eDOC USB (Optional).



Warning

Do not use damaged or defective console or accessories. Failure to follow this precaution can result in serious injury.



Warning

Only authorized personnel may perform modifications of the system.



Warning

Use of accessories, transducers and cables other than those specified or provided by the manufacturer of this equipment could result in increased electromagnetic emissions or decreased electromagnetic immunity of this equipment and result in improper operation.



Warning

Portable RF communications equipment (including peripherals such as antenna cables and external antennas) should be used no closer than 30 cm (12 inches) to any part of the Voluson™ Signature 18 / Voluson™ Signature 20, including cables specified by the manufacturer. Otherwise, degradation of the performance of this equipment could result.



Caution

The use of the equipment outside the described conditions or intended use, and disregarding safety related information is considered abnormal use. The manufacturer is not liable for injury or damage caused by abnormal use. Any abnormal use will void the warranty of the equipment.



Caution

Only use equipment provided by the system manufacturer GE ULTRASOUND KOREA, LTD.



Caution

Some parts of the system or probes may have come into contact with latex. Accessories such as probe sheaths may contain latex. There have been reports of severe allergic reactions to medical devices containing latex (natural rubber). Operators are advised to identify latex-sensitive patients and be prepared to treat allergic reactions promptly. Refer to FDA Medical Alert MDA91-1.



Caution

Cleaning and disinfecting agents can lead to skin irritations. Ensure that no residue of the cleaning or disinfecting agent remains on any part of the system after cleaning and disinfection.



Caution

It is highly recommended to create a full backup of settings and patient data regularly. The data from the backup always replaces the corresponding data on the Voluson™ Signature 18 / Voluson™ Signature 20.



Caution

Do not touch the patient and the signal input/signal output (SIP/SOP) connectors simultaneously.



Caution

Patients may have an (implanted) medical device which utilizes ultrasound waves for fulfilling its intended function. Consult and follow the instructions for use of the respective (implanted) medical device before scanning the patient with the Voluson ultrasound console.



Caution

Any electronic device can fail without warning signs, therefore the user is advised to follow local clinical practice guidelines for having a backup imaging plan when performing time-critical image-guided examinations and interventions. A wireless probe has a limited inherent risk of a disrupted connection due to various factors that could lead to loss of real time imaging.



Caution

If a temporary, unexpected disruption to real time imaging is determined to have a severely negative adverse effect on the patient's health outweighing the benefits of using a wireless probe at the point of care, it is recommended to consider using a wired ultrasound device for the specific procedure guidance.



Caution

Be careful when adjusting mechanical parts of the equipment.

- Ensure nothing is jammed.
- Do not put your hands or other body parts between movable parts of the equipment.
- Be careful when adjusting or locking the monitor.



Caution

Position the Voluson™ Signature 18 / Voluson™ Signature 20 so that the AC Mains circuit breaker and the AC Mains plug at the Mains wall-outlet is easily accessible at all times.



The user should be aware of the product specifications and of the system accuracy, functionality and stability limitations. These limitations must be considered before using the product for a specific application. These limitations must be considered also before making any decision based on quantitative values. Equipment malfunction or incorrect settings can result in measurement errors or failure to detect details in the image. The user must become thoroughly familiar with the operation of the unit in order to optimize its performance and to recognize possible malfunctions.



Caution

Disconnect AC Mains from AC Mains wall outlet to make the ultrasound console electroless.



Caution

Do not stare into the light beam of the LED.



Caution

Before use, especially after cleaning, disinfection or sterilization visually inspect the ultrasound probe, ultrasound console and accessories for damages or defects like cracks, cuts, sharp edges or exposed wiring. Before scanning the patient confirm expected ultrasound image functionality e.g. by scanning in air, applying ultrasound gel to the transducer, etc.



Warning

The use of the accessories, transducers, cables, etc. with any equipment other than the Voluson™ Signature 18 / Voluson™ Signature 20 may result in increased emissions or decreased immunity of the Medical Electrical equipment or Medical Electrical system.



Caution

The Voluson™ Signature 18 / Voluson™ Signature 20 is MR Unsafe.

MR systems (magnetic resonance imaging systems) produce magnetic fields and thereby attract magnetic materials and induce electric currents into conductive materials.

Note

GE ULTRASOUND KOREA, LTD. is not responsible for any damage caused by viruses, malware and other harmful software.

Note *The emissions characteristics of this equipment make it suitable for use in industrial areas and hospitals, e.g. professional healthcare environment (CISPR 11 class A). If it is used in a residential environment (for which CISPR 11 class B is normally required) this equipment might not offer adequate protection to radio-frequency communication services. The user might need to take mitigation measures, such as relocating or re-orienting the equipment.*

General precautions

Observe the following precautions:

- The user is responsible for the safety of all persons in the vicinity of the ultrasound system including the patient(s).
- Get acquainted with the probes and the ultrasound system.
- Misinterpretation of an ultrasound image can lead to false diagnosis.
- Image artifacts are inherent to physics of ultrasound image formation. These artifacts, such as mirroring due to the multiple propagation paths, velocity errors, attenuation errors, limitations due to beam width, side lobe, reverberation, comet tail, ring-down, speed displacement, refraction, shadowing, etc., may degrade the diagnostic image quality. Always consider the presence of image artifacts generated by the physical limitations of the modality.
- The system is sensitive to shock and must be treated with care also if not in use.
- Do not twist, kink or pinch cables. Excessive bending or stress on cables may result in damage to its insulating properties and functionality.
- Organize the cables (ultrasound probe cables, ECG cables, power cord, Ethernet LAN cable, video cables, USB cables etc.) to/from the ultrasound console in a way to minimize tripping hazards by e.g. using cable-hooks, bundling of cables, locating cables on the rear of the ultrasound console.
- Do not drop or subject the probe to any type of mechanical shock. Impact may compromise probe operation, safety features or result in sharp edges that could damage the protective sheath and / or injure sensitive tissue. Any damage caused by improper use will void the warranty.
- Installation and initial start-up of the system must be performed by authorized service personnel.
- Connectors and plugs of any kind (AC Mains, DC-voltage supply, signal input/signal output (SIP/SOP) connectors, ...) must always be firmly connected, i.e. the connector/plug must be completely pushed into the socket, to ensure good electrical contact.
When available, devices for connector/plug securing must be engaged.
- For safety reasons, avoid handling fluids in the vicinity of the system.
- Do not install software on the system that has not been released by GE HealthCare, as this may lead to erroneous function or function transfer and thereby decrease system performance.
- If continuous operation is required even during power interruption, it is recommended that the system is powered from an uninterruptable power source (UPS).
- Each person who connects additional equipment to the signal input portion or signal output portion configures a medical system, and is therefore responsible that the system complies with the requirements of the system standard IEC 60601. If in doubt, consult the technical service department or your local representative.
- The accessories, transducers, cables, etc. delivered with the Voluson™ Signature 18 / Voluson™ Signature 20 may not be used with any equipment other than the Voluson™ Signature 18 / Voluson™ Signature 20.

2.3 Electric Installation

Local safety regulations may require an additional connection between the potential equilibrium bolt and the building's grounding system.

Before connecting to power, ensure that the local AC Mains voltage and frequency correspond to the indicated power rating.

The minimum required house installation must have 10A.

Note *The potential equalization conductor reduces the risk of electric potential differences and thereby reduces the risk of electrical leakage current flow. For further information consult IEC60601-1.*



Warning

Never use an adapter which does not ensure proper protective earth connection.

To avoid the risk of electric shock, this equipment must only be connected to a supply AC Mains with protective earth.

Never remove or disconnect the protective earth.

Info *For more information see*

- 'Guidance and manufacturer 's declaration' on page 2-39
- Chapter 12
- Chapter 13

2.3.1 Inrush Current

During power-on, an inrush circuit prevents the current from increasing values stated below. Refer to the table below for inrush currents at various main voltages.

Voltage	Inrush Current
115VAC	25A max.
115VAC with UPS (SMART1200XLHG-AGSM1200PSR3HG series)	45A max.
230VAC	50A max.
230VAC with UPS (SMX1200XLHG-AGSM6834 series)	75A max.

Table 2-1 Inrush Current at different main voltages

Note *These values are estimate.*

2.4 Environmental conditions for operation



Warning

Do not use the equipment in oxygen rich environment (>25%) or in the presence of inflammable gases (e.g. anesthetic gases).



Warning

Use of this equipment adjacent to or stacked with other equipment should be avoided because it could result in improper operation. If such use is necessary, this equipment and the other equipment should be observed to verify that they are operating normally.



Caution

Do not operate the system in the vicinity of a heat source, of strong electric or magnetic fields (e.g. close to a transformer), or near instruments generating high-frequency signals, such as HF surgical equipment or magnetic resonance imaging equipment or similar. These can affect the ultrasound images adversely.

For more information see 'Safety conformance' on page 13-2.

General precautions

Observe the following precautions:

- Do not use the equipment during transportation (e.g. ambulance cars, aircraft).
- Using the system in sterile environment:
 - The ultrasound console cannot be sterilized. The use of protective console covers is not validated by the manufacturer GE ULTRASOUND KOREA, LTD..
 - It is in the responsibility of the user to use appropriate protective console covers from 3rd parties or have a non-sterile person operate the system.
 - Always follow the hygienic guidelines established by the institution where the ultrasound system is used.
 - The ultrasound probes cannot be sterilized. It is in the responsibility of the user to use sterile probe sheaths as described in the Instructions for Use.
- If the system has been moved from a cold (e.g. stockroom, airfreight) to a warm environment, wait for several hours before connecting to power (temperature balance and passing of condensation humidity).
- Do not cover the ventilation holes of the console or accessories.

This equipment generates, uses and can radiate radio frequency energy and, if not installed and used in accordance with the instructions, may cause harmful interference to other devices in the vicinity. However, there is no guarantee that interference will not occur in a particular installation. If this equipment does cause harmful interference to other devices, which can be determined by turning the equipment off and on, the user is encouraged to try to correct the interference by one or more of the following measures:

- Reorient or relocate the device.
- Increase the distance between equipment.
- Connect the equipment to an AC Mains outlet on a circuit different from that to which the other device(s) are connected.
- Consult the manufacturer or authorized service personnel for help.

Note

Over a wide frequency range the ultrasound image can be influenced by external electromagnetic fields. The frequencies of effect depend on the specific ultrasound probe in use. Influences may typically be visible in the operating frequencies of the ultrasound probes which are in the range of 1 MHz to 20 MHz and to a lesser extent also for other frequencies.

For more information see 'Safety conformance' on page 13-2.

2.5 Transport position

- Lower the user interface to its minimal height and move it to center position.
- Secure the monitor and accessories for transport.

2.5.1 User interface adjustment

Swiveling the user interface (UI)

1. Press the swivel button on the user interface handle to adjust the user interface angle.
2. Locate the user interface to center position.
3. Release the swivel button.

Adjusting the user interface in height

1. Press the Up/Down button on the user interface handle and keep it pressed
2. Lower down the user interface to the lowest position with grabbing user interface handle.
3. Release the Up/Down button.

2.5.2 Monitor adjustment

Securing the monitor for transport

1. Move the upper monitor arm parallel to the lower arm and push it down (A).
2. Rotate the monitor to the center position and turn the knob (B) counterclockwise until the arm rotation and height adjustment is locked.
3. Tilt down the monitor to lowest position.



2.6 Moving the System

Caution

Be careful when moving the system. Two people may be required when moving the system on inclines. Before moving the system observe the following:

- Lower the user interface to its minimal height and move it to the rear and center position.
- Secure the monitor and accessories for transport.
- Use the rear handle to move the system.
- Remove all obstacles.
- Move the system slowly and carefully in forward direction, see figure below.
- Avoid collisions with walls or door frames.
- Always place the system on horizontal ground and engage the caster brakes.
- Always ensure complete brake engagement on all 4 casters.
- Do not move the system when the brakes are engaged.
- Move the system forward or backward when going up or down inclines. Do not move the system sideways or diagonally.



Failure to follow these precautions could result in injury, uncontrolled motion and damage.

For further information on user interface and monitor adjustment read 'The user interface' on page 3-5 and 'Monitor adjustment' on page 2-17.

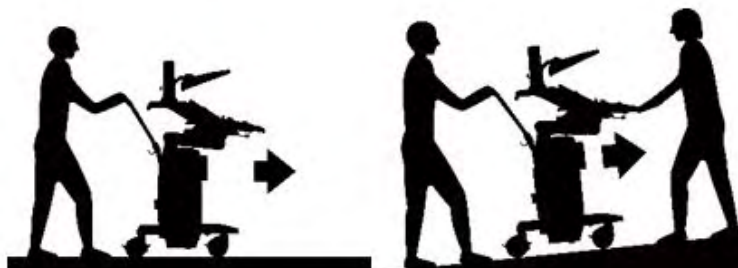

Figure 2-2 Moving the system on plains and inclines

Lifting the system

1. Preparation:
 - Disconnect all probes and transport them separately.
 - Disconnect the ECG module (if applicable) and transport it separately.
 - Ensure all peripheral devices (printer, ...) are firmly fixed within the system or transport them separately.
2. Have the Base cover removed by authorized personnel.
3. Pass a strap through the opening in the metal sheet.
4. Lift the system by the straps and the rear handle.

Caution

Always use a strap to lift the system.

- Two people are required when lifting more than 16 kg (35 lbs).
- Do not lift the system with the front handle of the user interface.



Transporting the System

Use extra care when transporting the system using vehicles. In addition to the instructions used when moving the system (see the chapter above), also perform the following:

1. Before transporting, place the system in safe place.
2. Only use vehicles that are designed for transport of the Voluson™ Signature 18 / Voluson™ Signature 20 system.
3. Load and unload the system to a vehicle parked on a level surface.
4. Ensure that the transporting vehicle can handle the weight of the system plus the passengers.
5. Ensure that the load capacity of the lift (a minimum of 154kg [340 lbs] is recommended) is capable of handling the weight of the system and any other items on the lift at the same time.
6. Ensure that the lift is in good working order
7. Secure the system while it is on the lift so that it cannot roll. Use either wood chocks, restraining straps, or other similar types of constraints. Do not attempt to hold it in place by hand.

Note *Strap the system below its handle so that the system does not break loose.*

8. Employ two to three persons to load and unload safely from a vehicle.
9. Load the unit aboard the vehicle carefully and over its center of gravity. Keep the unit still and upright.

Note *Do not lay the unit down on its side.*

10. Ensure that the system is firmly secured while inside the vehicle. Any movement, coupled with the weight of the system, could cause it to break loose.
11. Secure system with straps or as directed otherwise to prevent motion during transport.
12. Prevent vibration damage by driving cautiously. Avoid unpaved roads, excessive speeds, and erratic stops or starts.

2.7 Operating position

- Adjust the user interface to the desired height and angle.
- Adjust the monitor arm and put the monitor to the desired vertical position.

User Interface adjustment

For swiveling the user interface and adjusting the user interface in height see 'User interface adjustment' on page 2-17.

Monitor adjustment

Adjusting the monitor

The monitor can be moved forward and backward, adjusted in height and inclined.

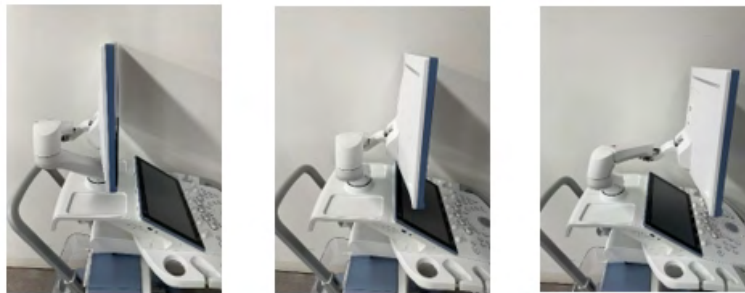

Figure 2-3 Adjusting the monitor back and forth.



Figure 2-4 Adjusting the height of the monitor.



Figure 2-5 Adjusting the inclination of the monitor.

2.8 Operation safety



Caution

Installation and initial start-up of the system must be performed by authorized service personnel.



Caution

Patient data from different systems are only distinguished by the patient identification (ID) field! Ensure that all patients receive a unique patient identification (ID). Digital patient data is only identified by the patient ID. Once the patient ID has been assigned it cannot be changed. If the ID is not unique, data may be overwritten or mixed.



Caution

Before saving, editing, or reviewing the data of a patient, ensure that its contents correspond to the patient name. This provides additional assurance that the stored data correspond to the correct patient. Not obviously incorrect behavior could lead to conflicting information.

Image quality

Caution

The quality of the image used for diagnosis is essential:



- Changing the display/monitor settings can affect the image quality and compromise the diagnostic quality. The user is responsible to use adequate display/monitor settings for achieving appropriate image quality. If in doubt, only the image as displayed on the main monitor of the Voluson ultrasound system with default display/monitor settings is to be used for diagnostic purposes.
- Do not diagnose based on print-outs.



Caution

A lossy image compression can reduce image quality which can lead to a false diagnosis!



Caution

Filters smoothen (indicated as SRI, CRI in the image-information section) the final image (structures may be smeared out). For diagnostic purposes, this must be taken into account or the Region of Interest must be checked without filters.



3D/4D Acquisition data generated with mechanical 3D/4D probes are subject to limited accuracy in elevational direction. For diagnostic purposes, this must be taken into account or the Region of Interest must be checked using B-Mode Acquisition.



VCI-A (indicated by a VCI-A in the image-information section, respectively) is an image acquisition mode which uses volume-data for the image generation. Note that this may alter the appearance of the Ultrasound information displayed. For diagnostic purposes, this must be taken into account or the Region of Interest must be checked without VCI-A.



Caution

Radiantflow (indicated by a topographic color-bar in the image-information section) is a display method which uses the amplitude of the Color flow signal. Note that this may alter the appearance of the Ultrasound information displayed. For diagnostic purposes, this must be taken into account or the Region of Interest must be checked without **Radiantflow**



Caution

Shadow Reduction (indicated as SR in the image-information section) is an image processing algorithm which reduces the effect of acoustic shadowing. Note that this may alter the appearance of the Ultrasound information displayed. For diagnostic purposes, this must be taken into account or the Region of Interest must be checked without **Shadow Reduction**.

Caution



Augment (indicated as **Augment** the image information block) is a technology that helps to help reduce scanning artifacts by adjusting ultrasound settings and image filters. Note that this may alter the appearance of the ultrasound image information displayed. For diagnostic purposes, this must be considered and it is recommended to confirm information without **Augment** as needed.

Caution



Pay attention when displaying DICOM images that originate from another product or a general DICOM device/archive. Such DICOM images may be incomplete, e.g. due to different other product DICOM setup/configuration, a use error or other device malfunction. Any incorrect or missing information is in the responsibility of the user. Possible relevant clinical implications need to be taken into account by the user.

Caution



Autolive (indicated by the icon  in the image-information section) is an image processing algorithm which optimizes the tissue gain in real-time. Note that this may alter the appearance of the Ultrasound information displayed. For diagnostic purposes, this must be taken into account or the Region of Interest must be checked without Autolive.

Specific modes and features

Caution



Features that facilitate measurements such as Fibroid Mapping, SonoAVC™*follicle*, SonoVCAD™*labor*, VOCAL or SonoNT, SonoCNS, SonoBiometry, SonoPelvicFloor and fetalHS must be used with extreme care. The measurement results are a suggestion of the system, if in doubt verify with manual measurement methods. The user is responsible for the diagnostic interpretation of the measurement results.

Caution



Features that facilitate selection of images such as fetalHS, SonoVCAD™*heart*, SonoLystX, SonoLystIR, SonoLystlive¹ or selection of planes such as SonoPelvicFloor and SonoCNS² must be used with extreme care. The selection results are a suggestion of the system. The user is responsible for the selection of images.

Caution



Features that facilitate identification of criteria in images such as SonoLystX, SonoLystlive³ must be used with extreme care. The identification results are a suggestion of the system. The user is responsible for the identification results.

Caution



- Be aware that diagnostic conclusions must not be drawn from a specific mode, such as Render Mode or XTD-Mode. Always check with other diagnostic procedures.
- The accuracy of measurements in specific modes such as Render Mode, XTD, MagiCut, STIC or VOCAL⁴ is limited and can be lower than measurements in B-images.
- If a yellow caution symbol is displayed on the screen/Report, it indicates that the measurement accuracy is compromised in the selected mode.

Caution



The results achieved in Elastography Mode always depend on the precision of the procedure performed. Any clinically relevant decisions need to be verified with other state of the art methods.

1 Please note that this list is indicative only.

2 Please note that this list is indicative only.

3 Please note that this list is indicative only.

4 Please note that this list is indicative only.

Contrast media

	<p>Caution</p> <ul style="list-style-type: none"> • Cavitation may occur due to interactions between the ultrasonic waves and the contrast medium. Always perform examination using the ALARA (As Low As Reasonably Achievable) principle. The acoustic power can be adjusted by rotating the Transmit Power button on the user interface. • Stop the examination and perform appropriate treatment, if there is any abnormality with the patient during use of the contrast medium.
---	---

	<p>The Voluson™ Signature 18 / Voluson™ Signature 20 system is designed for compatibility with most commercially available ultrasound contrast agents. Availability of these agents is subject to government regulation and approval. Contrast imaging should be performed within the approved indications for use of the contrast agent used in the exam.</p>
---	--

<p>Remark</p>	<ul style="list-style-type: none"> • Handle the contrast medium as described in the Instructions for Use supplied with the contrast medium. • Check the side effects of the contrast medium used with the manufacturer of the contrast medium. • GE ULTRASOUND KOREA, LTD. is not liable for any damage or injury resulting from improper use of contrast media.
----------------------	--

Probe orientation

	<p>Caution</p> <p>Ensure that the actual probe position corresponds to the probe orientation configuration.</p> <p>Special precision is required in Acquisition Mode 4D. Moving the probe can lead to errors in displayed directions with respect to the displayed image.</p>
--	---

Reporting

In case a serious incident occurred in relation to Voluson™ Signature 18 / Voluson™ Signature 20 system ultrasound products, this should be reported to GE HealthCare and the competent Authority.

2.9 Cleaning and disinfecting the system

To ensure the safe and effective use of the ultrasound system, it should be cleaned and disinfected in accordance with the instructions given. In general, keep the medical device, its components and its peripherals clean. Before and after each cleaning and disinfection, the device and its components must be carefully visually inspected. If there are visible signs of damage or wear, the affected parts and components may no longer be used.



Warning

Before applying cleaning or disinfection liquids to the Ultrasound console, switch it off and disconnect AC power.



Caution

- Do not spill liquids on the system in order to protect electrical parts.
- If you use a spray or liquid, do not apply it directly onto the system. First, apply it on a non-abrasive cloth and then wipe the system with the cloth. Excessive liquids must be removed immediately with a non-abrasive cloth to prevent liquids from entering the system.
- Electrical contacts and connectors must not be touched.
- Only use cleaning or disinfection agents listed in the table below.
- Reusable accessories should be cleaned and disinfected or sterilized as stated by the manufacturer, after each patient examination.

Parts which have a frequent user interaction like key caps, buttons, knobs, upper case of the user interface, touchscreen, front handles used to move the user interface, probe holder areas, should be cleaned and disinfected with low-level disinfection (LLD) after every patient.

Parts which have an occasional user interaction like back handles to transport the whole Ultrasound console, covers, trays, footrest, monitor arm, monitor should be cleaned and disinfected with low-level disinfection (LLD) twice a day.

Parts which have an unlikely user interaction like other exterior parts that are difficult to touch, trolley bottom cover, should be cleaned and disinfected with low-level disinfection (LLD) once a month.

Note *The cleaners and disinfectants listed in the table below can be used anywhere on the system (Operator Panel, Monitor, Probe Holders etc), except for the probes. Refer to 'Cleaning and maintenance of probes' on page 5-5 for probe cleaner and disinfectant information and web links.*

Always consult the cleaner or disinfectant manufacturer's instructions for proper use of their product. Wear appropriate PPE as indicated by the chemical manufacturer.

List of approved cleaning and disinfection agents

The following table provides cleaning and disinfection instructions for the ultrasound device. It is the responsibility of the user to decide which cleaning and disinfection procedure is necessary to ensure a safe working environment.

- Electrical contacts and connectors must not be cleaned.
- Only use cleaning agents listed in the below table.
- Do not use high-proof alcohol (over 70%) for cleaning or disinfecting the system.
- If you use a spray, apply it to a non-linting cloth and then wipe the system. Do not apply spray directly onto the system, to prevent liquids from entering.
- When processing the operator control panel, make sure not to spill or spray any liquid on the controls, into the system cabinet, or in the probe connection receptacle.

Refer to the Instructions for Use of each individual cleaning/disinfection agent for further specific instructions (e.g., safety precautions, application, concentration, temperature and wet time).

Component	Probe holder	User Interface*	Touch Panel	Monitor display	Housings	Trackball	Probes	Air Filter	Peripherals(e.g. Printers)	
When to clean	See 'Maintenance schedule' for more information									
Cleaning/Disinfection Agent	Acrly-Des Wipes **	X	X	X	-	X	X	See Probe Care Card and 'Cleaning and maintenance of probes' on page 5-5	Clean with a vacuum cleaner from the outside	Clean according to the instructions for the peripheral manufacturer
	Klercide™ 70/30 IPA	X	X	X	X	X	X			
	PDI Easy Screen Cleaning®**	X	X	X	X	X	X			
	Sani Cloth 70 Wipes**	X	X	X	X	X	X			
	Cleanisept Wipes**	X	X	X	-	X	X			
	Clinell Universal Sanitizing Wipes**	X	X	X	-	X	X			
	Descosept Pur Wipes**	X	X	X	-	X	X			
	Incidin Oxy Wipes S**	X	X	X	-	X	X			
	Lonza Disinfectant Wipes Plus 2**	X	X	X	-	X	X			
	Lonza Formulation DC-103	X	X	X	-	X	X			
	Mikrozyd Universal Wipes**	X	X	X	-	X	X			
	ProSpray Wipes**	X	X	X	-	X	X			
	Protex Disinfectant spray	X	X	X	-	X	X			
	Protex Ultra Disinfectant Wipes**	X	X	X	-	X	X			
	Sono Ultrasound Wipes**	X	X	X	-	X	X			
	Oxivir TB Wipes**	X	-	X	-	-	X			
	CaviWipes1**	X	X	X	-	X	X			
	Descogen Oxy Wipes**	X	X	X	-	X	X			
	Umonium38 Neutralis Tissues**	X	X	X	-	X	X			
	Super Sani-Cloth Wipes**	X	-	X	-	X	X			
Sani-Cloth AF3 Germicidal Disposable Wipes**	X	X	X	-	X	X				
Sani-Cloth Plus Germicidal Disposable Cloth**	X	-	X	-	X	X				
Clorox Hydrogen Peroxide Cleaner Disinfectant Wipes**	X	X	X	-	X	X				
Lerasept HD	X	-	X	-	-	X				

Table 2-2 List of approved cleaning and disinfection agents

X: can be used on the component of the ultrasound console

-: do not use on component of the ultrasound console

** : Wipes can be used directly on console

Note For more information, visit to <https://cleaning.gehealthcare.com/>

* Effective cleaning for parts with narrow gaps and holes (e.g. keyboard, trackball,...) is not possible.

Removable parts for cleaning and disinfection

Remove trackball

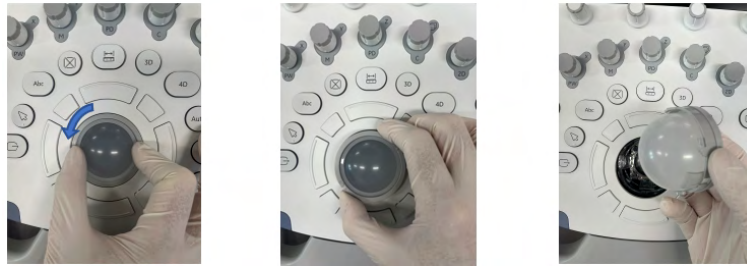

Install trackball

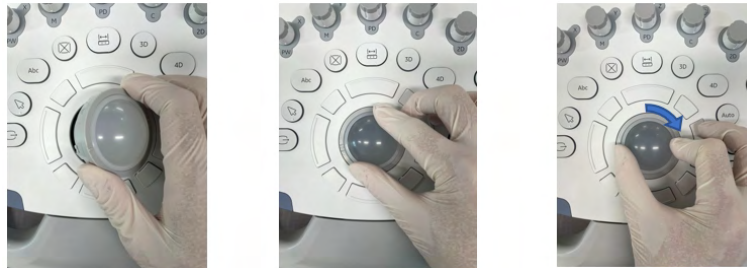

Remove Air filter



- Lock the wheels before cleaning and disinfecting the air filters to avoid injury by any unexpected movement of the system. Electrical contacts and connectors must not be cleaned.
- DO NOT operate the unit without the air filters in place.
- Allow the air filters to dry thoroughly before re-installing them on the unit.

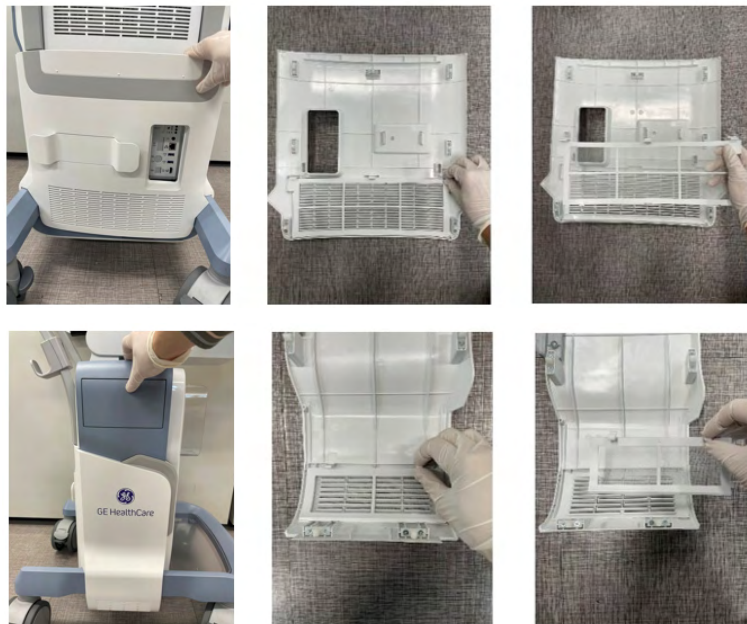

1. Pull the rear cover and side cover (left & right) with hand.
2. Unhook the air filter hook from the cover.
3. Detach the air filter.

Clean the air filter with a vacuum cleaner. As the local dust exposure strongly varies, the cleaning interval needs to be adjusted on local experience of dust collection on the filter. The minimum cleaning interval is once a month.

Install Air filter : Install Air filter is reverse order of removal process.

Cleaning

The purpose of cleaning is to remove visible dirt and to ensure the proper and safe function of the system.

If the device is visibly soiled the console and its components should be cleaned manually. Additionally, before disinfection activities, the medical device and its components should be cleaned to remove contamination and visible residues, dust and dirt.

- If required, remove the removable parts as described above.
- The operator is responsible to choose the proper cleaning agent from the list above to suit the individual needs of cleaning.
- Refer to the Instructions for Use of each individual cleaning agent for further specific instructions (e.g., personal safety equipment, safety precautions, application, concentration, temperature and wet time).
- When using cleaning wipes, dispense a cleaning wipe from the wipe canister. If using a spray, spray on a clean cloth to use as wipe.
- Gently wipe the whole surface of the system with the cleaning wipe until all visible residues and soils are removed. Pay special attention to the notches, curvatures and edges.
- As the wipe becomes visibly soiled, discard the wipe into clinical trash and dispense new wipes as needed.
- Visually inspect the console and its parts after cleaning is completed. If this monitoring shows the presence of residual contaminants, dirt or soil, these parts should be cleaned again according to the procedure described until they are visibly clean. If any defects (corrosion, discoloration, damages or cracks) are observed or malfunction occur, do not operate the medical device and inform a qualified GE Service Representative.
- For cleaning probes, refer to Probe Care Card and 'Cleaning and maintenance of probes' on page 5-5.
- For cleaning peripherals (e.g. printers), refer to the instructions of the peripheral manufacturer.

Note *Do not apply a spray or any liquid directly on the system.*

Note *Do not scratch or press on the display-panel with any sharp item as this may cause damage.*

The air filters and the connector area at the back of the system (see image below) need to be cleaned with a vacuum cleaner. As the local dust exposure strongly varies, the cleaning interval needs to be adjusted on local experience of dust collection on the filter. The minimum cleaning interval is once a month.

Disinfection

The purpose of disinfection is to reduce microorganisms on the surfaces of the ultrasound system to an appropriate level and to ensure the safe use.

- Remove visible dust and dirt by cleaning before disinfection activities.
- If required, remove the removable parts as described above.
- The operator is responsible to choose the proper disinfection agent from the list above to suit the individual needs of disinfection.
- Refer to the Instructions for Use of each individual disinfection agent for further specific instructions (e.g., personal safety equipment, safety precautions, application, concentration, temperature and wet time).
- If using a disinfectant spray or liquid, spray enough disinfectant solution to saturate a new disposable non-linting and non-abrasive wipe or cloth. When using disinfectant wipes, dispense a new wipe from the wipe canister.

- Gently wipe the whole surface to wet the system. Scrubbing or high pressure is not necessary within the disinfection process.

Note *Please refer to specific instructions for areas that are likely to be a source of cross-contamination.*

- The surfaces should remain wet for the appropriate wet time specified by the disinfectant manufacturer.
- If the surface does not remain wet for the required exposure time specified by the disinfectant manufacturer, use another wipe or cloth to prolong the wet time.
- Afterwards, thoroughly dry all surfaces using a soft, non-linting wipe or cloth, changing wipes/cloths when necessary to ensure the parts are completely dry.
- Visually inspect the console and its parts after disinfection is completed. If this monitoring shows the presence of residual contaminants, dirt or soil, these parts should be cleaned and disinfected again according to the procedure described above until they are visibly clean. If any defects (corrosion, discoloration, damages or cracks) are observed or malfunction occur, do not operate the medical device and inform a qualified GE Service Representative.
- For disinfecting probes, refer to Probe Care Card and 'Cleaning and Disinfection of Probes' on page 5-6.
- For disinfecting Peripherals (e.g. Printers), refer to the instructions of the peripheral manufacturer.

Note *Due to the geometrical complexity of the ultrasound system (e.g. buttons and gaps), it is technically not possible to apply cleaning and disinfection agents on all areas. Therefore, GE HealthCare recommends the use of a sterile system drape (e.g. CIVCO part number 610-025), when using the ultrasound system in areas of enhanced hygienic requirements.*

Further instructions for parts that are likely to be a source of cross-contamination

These parts are subject to be a likely source of cross-contamination:

- Left and right Probe Holder
- Gel Holder/ Gel Warmer
- Endocavity probe Holder



- NEVER use any cleaner or disinfectant containing alcohol.
 - When cleaning/disinfecting probes using a spray cleaner/disinfectant, DO NOT spray the probe while the probe is set in its probe holder on the Ultrasound system.
-

For general cleaning and disinfection steps of these parts see instructions above.

In addition, pay special attention to the notches and curvatures of these holders. Prolonged soaking or scrubbing with a soft brush (such as a toothbrush) may be necessary if material has dried onto the surface.

Follow the shown wiping instructions for left and right Probe Holders and Gel Holder/ Gel Warmer:



Figure 2-6 Cleaning and disinfection of the right Probe holder. Repeat with shown procedure on the whole part



Figure 2-7 Cleaning and disinfection of the left Probe and Gel Holders. Repeat with shown procedure on the whole part

Note *It is not required to detach the Probe Holder from the system for effective cleaning and disinfection. Anyhow, Probe Holder inserts (no Gel Warmer) can be detached for very ergonomic and easy accessibility.*

Note *If an optional Gel Warmer is included, the Gel Warmer cannot be detached from the Probe Holder. Do not rinse the Gel Warmer and its connector.*

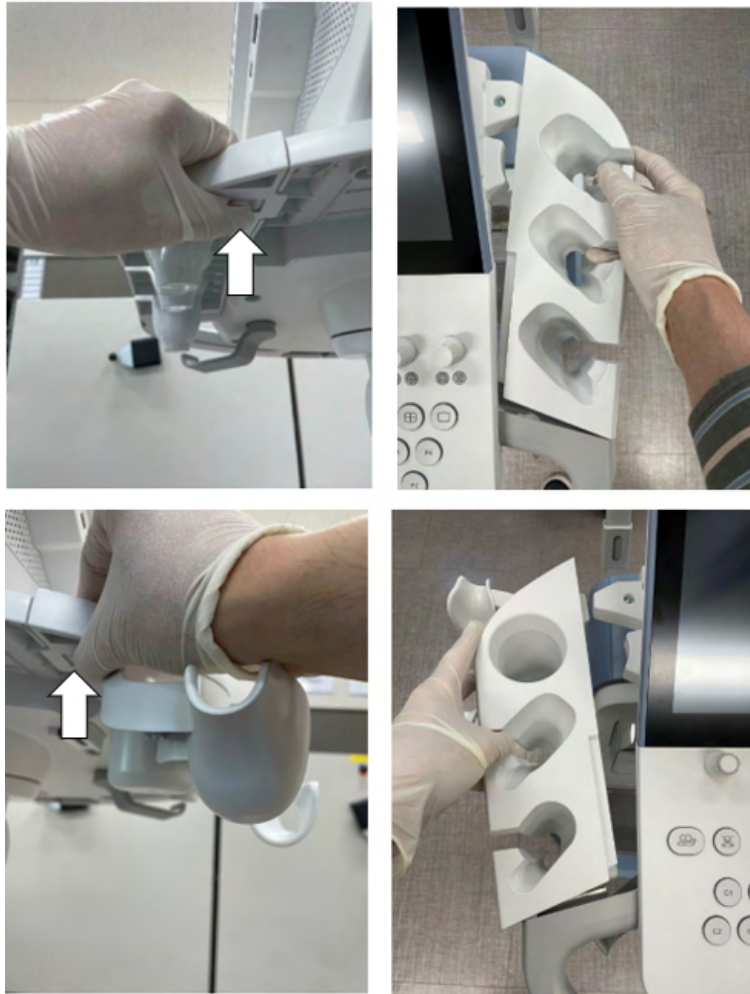

Figure 2-8 Removal of the left and right Probe Holder . For installation, just push them back on the user interface until you hear a "click" sound.

Follow the shown wiping instructions for the Endocavity probe holders:

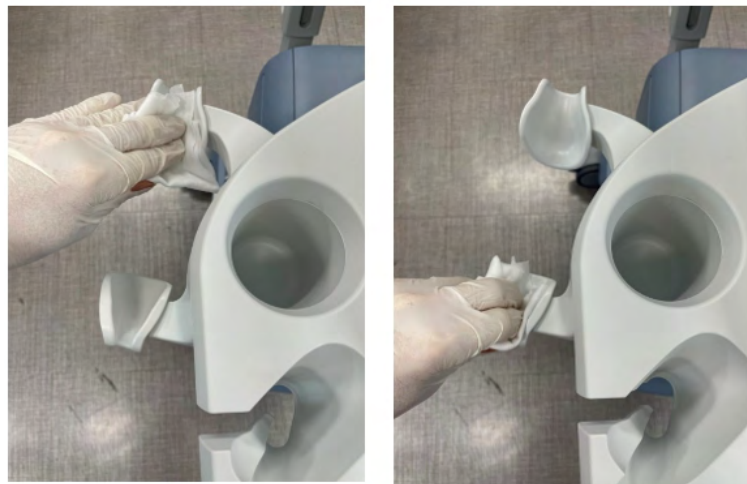

Figure 2-9 Cleaning and disinfection of the Endocavity probe holder. Repeat with shown procedure on the whole part and all crosspieces.

Note

It is not required to detach the Endocavity probe holders from the system for effective cleaning and disinfection. Anyhow, they can be detached with Probe holder assembled for very ergonomic and easy accessibility.



Figure 2-10 Removal of the left with Endocavity probe holder attached. For installation, just push them back into the user interface until you hear a “click” sound.

2.10 Maintenance



Warning

- Check all cables, plugs and sockets on a regular basis.
- Covers and panels must not be removed from the system.



Caution

Periodic Maintenance Inspections

It has been determined by GE HealthCare that your Voluson™ Signature 18 / Voluson™ Signature 20 system does not have any high wear components, therefore no Periodic Maintenance Inspections are mandatory. However, to maintain the safety and performance of the ultrasound system, a regular check by authorized personnel remains recommended.

Remark

Attempting do-it-yourself repairs invalidate warranty and are an infringement to regulations and are inadmissible acc. to IEC 60601-1. Only authorized personnel may perform service and repairs. For expected lifetime of equipment and probes see Service Manual.

For probe specific information see: 'Cleaning and maintenance of probes' on page 5-5

Maintenance Schedule

Follow this Maintenance Schedule to maintain optimum system function and patient care:

Monthly	Weekly	Daily	After Each Patient
Inspect the following on an monthly basis: <ul style="list-style-type: none"> • Connectors on cables for any mechanical defects. • Entire length of electrical and power cables for cuts or abrasions. • Equipment for loose or missing hardware. • Control panel and keyboard for defects. • Casters for proper movement and locking operation. • Trackball movement. If the trackball is dusty, please clean it. 	Clean the following on a weekly basis: <ul style="list-style-type: none"> • System Cabinet • Monitor • LCD panel and the Touch Panel • Operator Controls Panel • If the probe holder is dusty, please clean it. • Removable Trackball/ Trackball • Air Filters (weekly or as needed) If the air filter is dusty, please clean it. • Footswitch • B/W Printer 	Clean and disinfect the following areas where cross contamination can occur: <ul style="list-style-type: none"> • Monitor • LCD Panel and the Touch Panel • Operator Controls Panel • Front and Rear Handles 	Clean and disinfect the following after each patient: <ul style="list-style-type: none"> • Probe • Biopsy Bracket, as applicable • Additionally, clean and disinfect any area on the system that has visible contamination from the previous exam. <p>Note <i>Biopsy Accessories must be cleaned and disinfected or disposed of after each patient. Refer to the Chapter 5</i></p>

Table 2-3 Maintenance Schedule

Note

Frequency of the cleaning and disinfection is depended on environment. Failure to perform required maintenance may result in unnecessary service calls.



- To avoid electrical shock hazard, do not remove panels or covers from console. This service must be performed by qualified service personnel. Failure to do so could cause serious injury.
- If any defects are observed or malfunctions occur, do not operate the equipment but inform a qualifie dservice person. Contact a Service Represnetative for information.

Safety test

Recommended maintenance schedule: According to respective national regulations, and according to the manufacturer recommendations for the medical-electrical system.

Test	Action
Visual inspection	Checking of housing, connections, operating elements, display facilities, labels, accessories, Instructions for Use.
Functional test	Checking of functions (according to Instructions for Use), check also modular combinations and common operability of system and accessories.
Electric test	Checking of the electric safety of system combinations according to IEC62353 or respective national regulations.

Table 2-4 Safety tests

Item	Frequency	Notes
Console leakage current	Annually	Also after corrective maintenance or as required by your facilities QA program.
Peripheral leakage current	Annually	Also after corrective maintenance or as required by your facilities QA program.
Probe leakage current	Annually	Also after corrective maintenance or as required by your facilities QA program.

Table 2-5 Leakage current tests

2.11 Disposal



Caution

Dispose of the system according to manufacturers' instructions and in accordance with your local regulations.

For accessing the WEEE passport of the GE ULTRASOUND KOREA, LTD. products please:

1. Go to the GE HealthCare Customer Documentation Portal:
<https://www.gehealthcare.com/support/manuals>
 2. Select the modality "Ultrasound (UL)".
 3. Enter the document name or the keyword "WEEE".
 4. Click **Search**.
 5. Select the desired WEEE passport.
-



Caution

Lithium batteries are included with several products of GE ULTRASOUND KOREA, LTD. Do not puncture, mutilate or dispose of battery in fire. Replace only with same type recommended by the manufacturer. Dispose of used battery according to manufacturers' instructions and in accordance with your local regulations.

The separate collection symbol is affixed to a battery, or its packaging, to advise you that the battery must be recycled or disposed of in accordance with local or country laws. To minimize potential impacts to the environment and human health, it is important that all marked batteries that you remove from the product are properly recycled or disposed. For information on how the battery may be safely removed from the device, please consult the equipment instructions or your local authorities.

Safe Product and Packaging Disposal

This product and package should be disposed of according to hospital disposal practices, and local environmental and waste disposal regulations. Components and accessories of the Voluson™ Signature 18 / Voluson™ Signature 20 which have come into direct or indirect contact with the patient may be biohazardous, and should be disposed of according to facility guidelines for biohazardous material. The waste of electrical and electronic equipment must not be disposed as unsorted municipal waste and must be collected separately. Please contact an authorized representative of the manufacturer for information concerning the disposal / decommissioning of equipment.

2.12 Bioeffects and Safety of Ultrasound Scans

When ultrasound waves travel through tissue, there is a certain risk for damage. There has been substantial research on the impact that high frequency waves can have on different kinds of tissues under defined conditions and “There is, to date, no evidence that diagnostic ultrasound has produced any harm to humans – including the developing fetus.” (Guidelines for the safe use of diagnostic ultrasound equipment, Safety Group of the British Medical Ultrasound Society 2010).

Physiological effects due to ultrasound are generally assumed to be deterministic and only occur above a certain threshold in contrast to ionizing radiation, which causes effects accidentally. Thus ultrasound examinations can be held very safe if certain proceedings are followed. It is therefore recommended to read the following sections and study the cited literature.

2.12.1 Prudent Use – ALARA Principle

In spite of the relatively low risk of ultrasound scans compared to other imaging techniques, the operator shall choose the exposure level with caution to minimize the risk of bioeffects.

“A fundamental approach to the safe use of diagnostic ultrasound is to use the lowest output power and the shortest scan time consistent with acquiring the required diagnostic information. This is the **ALARA** principle (i.e. **As Low As Reasonably Achievable**). It is acknowledged that in some situations it is reasonable to use higher output or longer examination times than in others: for example, the risks of missing a fetal anomaly must be weighed against the risk of harm from potential bioeffects. Consequently, it is essential for operators of ultrasound scanners to be properly trained and fully informed when making decisions of this nature.” (Guidelines for the safe use of diagnostic ultrasound equipment, Safety Group of the British Medical Ultrasound Society 2010)

Special care regarding ALARA should be taken with obstetric examinations as any potential bioeffects are likely to be of greatest significance in the embryo or fetus.

It is strongly recommended to consider ALARA when undertaking ultrasound scans.

2.12.2 Bioeffects

- Thermal effects refer to heating of soft tissue and bone

The thermal indices TI_s (soft tissue), TI_b (bone near focus) and TI_c (bone near surface) were introduced to provide the operator a relative potential for a tissue temperature rise. It should be noted that a TI of 1 does not necessarily mean that tissues being scanned will increase in temperature by 1 °C – almost every scanning situation departs from the assumed model conditions, such as tissue type, blood perfusion, mode of operation and actual exposure time of the scanned area. However, the thermal indices provide information regarding the possible increase in the risk of potential thermal bioeffects and it provides a relative magnitude that can be used to implement ALARA. In addition to tissue heating due to the generated ultrasound field, the temperature of the probe head itself can also increase during the examination. The operator shall be aware, that in the tissue region near the ultrasonic transducer, there will be a superposition with the heating due to the ultrasound field, which is not considered by the TI values.

Due to these effects it is likely that the temperature of patient tissue next to the ultrasound probe increases. Although this biological effect might occur, it is not necessarily hazardous as healthy human cells are obviously able to survive small temperature rises. The current scientific state of the art concerning temperature hazards is still incomplete at the moment. Nevertheless evidence exists about thermal teratology, exposure levels and temperature rise that states that short-time application of ultrasound probes is acceptable from a risk perspective.

- Nonthermal effects refer to mechanical phenomena such as cavitation

Nonthermal bioeffects are caused by the interaction of ultrasound fields with very small pockets of gas (stabilized gas bodies), i.e. the generation, growth, vibration and possible collapse of microbubbles within the tissue. This behavior is referred to as cavitation (Medical Ultrasound Safety, 4th Edition, AIUM 2020/American Institute of Ultrasound in Medicine Consensus Report on Potential Bioeffects of Diagnostic Ultrasound, AIUM 2008/Guidelines for

the safe use of diagnostic ultrasound equipment, Safety Group of the British Medical Ultrasound Society 2010). The potential of cavitation increases with the rarefactional peak pressure but decreases with increasing pulse frequency.. Therefore the Mechanical Index MI was introduced to take account of both the pressure and the frequency. The higher the MI the greater is the risk of nonthermal bioeffects.

2.12.3 Regulated Parameters

Relevant parameters having physiological effects (*For more information see 'Bioeffects' on page 2-35.*) are regulated according to FDA and IEC guidelines and standards. These parameters are

Parameter	Meaning	Limit	Displayed
MI	Mechanical Index	1.9	Yes
TIs, TIb, TIc	Thermal Indices TI – one of the following values can be displayed: TIs: soft tissues TIb: bone in focal region TIc: bone at surface (e.g. cranial)	6	Yes
Ispta.3	Averaged intensity at spatial peak with a derating of 0.3dB/(cm MHz)	720 mW/cm ²	No
T	Temperature at the patient's side of the probe – lower limit during patient contact, higher limit for rest position	43 °C/50 °C (109.4 °F/122 °F)	No

2.12.4 Interpretation of displayed parameters MI and TI

During obstetric examinations these displayed values shall be observed very critically, because there may be conditions that are potentially hazardous even below the regulatory limits.

Some guidelines recommend that embryonic and fetal in situ temperatures of 41 °C (4 °C above normal temperature) should be limited in time by 5 min or less. Thus, for a reasonable safety margin, TI values above 1 should be avoided. Additional factors, like temperature of the mother, are again reasons to keep the TI values as low as possible on the one hand, and go only as high as necessary to achieve the desired clinical results ('Prudent Use – ALARA Principle' on page 2-35).

The mechanical index, which indicates the risk of cavitation, becomes important at the interface between gas and soft tissue (nonfetal lung and bowel), but also with the use of gas body contrast agents. Often a MI value of 0.4 or less is suggested for examinations of tissue containing stabilized gas bodies. This value arises from operating experience and is not confirmed.

Some examples where the MI and TI, respectively, are more or less important are shown in the following table according to *Particular requirements for the basic safety and essential performance of ultrasonic medical diagnostic and monitoring equipment, IEC 60601-2-37.*

According to the FDA (*Enforcement Policy for Imaging Systems During the Coronavirus Disease 2019 (COVID-19) Public Health Emergency; Guidance for Industry and Food and Drug Administration Staff April 2020*) the MI value should be below 1.4 in case of scanning on tissues containing gas bodies (e.g. lung). The corresponding MI value displayed on the Voluson console is 0.9. This difference in the MI values is due to the effects of probe to probe variation as well as the calculation accuracy of the displayed MI value. Therefore, in case of scanning on tissues containing gas bodies the settings should be chosen so that the MI value displayed on the Voluson console is ≤ 0.9 . The displayed MI value can be controlled by adjusting the U/S power accordingly.

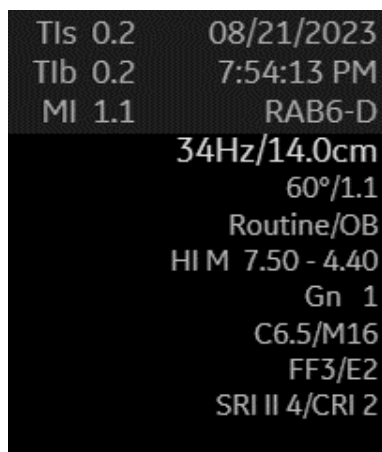

Predefined modes/settings that fulfill the recommendations of the FDA (*Enforcement Policy for Imaging Systems During the Coronavirus Disease 2019 (COVID-19) Public Health Emergency; Guidance for Industry and Food and Drug Administration Staff April 2020*) are indicated by the display of the



following lung-symbol: . The symbol indicates the suitability of the modes/settings which are maintained also when the user manually changes these predefined modes/settings. The acoustic power is limited accordingly by the system.

	Of greater importance	Of less importance
MI – Mechanical Index	With contrast agents Cardiac scanning (lung exposure) Abdominal scanning (bowel gas)	In the absence of gas bodies, i.e. most tissue scanning
TI – Thermal Indices	1st trimester scanning Fetal skull and spine Neonatal head Patient with fever Poorly perfused tissue Scanning near ribs or bone: Tib	Well perfused tissue, i.e. liver, spleen Cardiac scanning Vascular scanning

Further information can be retrieved from *Medical Ultrasound Safety, Fourth Edition, AIUM, 2020 and Evaluation of Research Reports: Ultrasound Bioeffects Literature Reviews (1992-2003)*.

Accuracies of acoustic parameters

The parameters MI, and the thermal indices, TIs, Tib and Tic are calculated by the ultrasound system depending on the connected probe and the chosen application setting. For their interpretation and further explanations please refer to the Instructions for use of the console. The mechanical index MI and the thermal indices TIs, Tib and Tic are displayed with at least 1 decimal place, starting from 0.1. From a value of 0.4 the deviation from measurements is less than $\pm 25\%$ for MI and less than $\pm 50\%$ for TIs, Tib and Tic.

Parameters for Ophthalmic Artery settings

According to the FDA (Marketing Clearance of Diagnostic Ultrasound Systems and Transducers; Guidance for Industry and Food and Drug Administration Staff) the following restriction for acoustic output in case of scanning through the closed eye should be used: $TI = \text{Max}(TIS_{as}, TIC)$ should be ≤ 1 ; $ISPTA.3 \leq 50 \text{ mW/cm}^2$; and $MI \leq 0.23$. The corresponding values displayed on the Voluson console are $TI \leq 0.5$ and $MI \leq 0.2$. ISPTA.3 is not visible for the user. The difference in the ultrasound system values and FDA recommendation is due to the effects of probe to probe variation as well as the calculation accuracy of the displayed values. TI and MI values can be controlled by adjusting the U/S power accordingly.

Note *The TIs_{as} describes the thermal index soft tissue at surface. The TIs displayed on the console monitor shows the maximum of the thermal index soft tissue at surface and the thermal index soft tissue below surface.*

Predefined modes/settings that fulfill the FDA ophthalmic usage recommendations are indicated by

the display of the following ophthalmic artery-symbol: . The symbol indicates the suitability of the modes/settings which are maintained also when the user manually changes these predefined modes/settings. The acoustic power is limited accordingly by the system.

2.12.5 Reporting Tables

Acoustic output reporting tables according to the below cited standards are provided in the *Advanced Acoustic Output References*.

Particular requirements for the basic safety and essential performance of ultrasonic medical diagnostic and monitoring equipment, IEC 60601-2-37.

Marketing Clearance of Diagnostic Ultrasound Systems and transducers, FDA Guidance.

Note *The device follows FDA Track 3 recommendations for acoustic output.*

Ultrasonics - Field characterization - Test methods for the determination of thermal and mechanical indices related to medical diagnostic ultrasonic fields, IEC 62359

2.13 Guidance and manufacturer 's declaration

Guidance and manufacturer 's declaration - electromagnetic emissions		
<p>The Voluson™ Signature 18 / Voluson™ Signature 20 system is intended for use in electromagnetic environment specified below. The customer or the user of the Voluson™ Signature 18 / Voluson™ Signature 20 system should assure that it is used in such an environment.</p>		
Emission test	Compliance	electromagnetic environment - guidance
CISPR 11/EN55011 Conducted and radiated RF EMISSIONS	Group 1	The Voluson™ Signature 18 / Voluson™ Signature 20 system uses RF energy only for its internal function. Therefore, its RF emissions are very low and are not likely to cause any interference in nearby electronic equipment.
	Class A	The Voluson™ Signature 18 / Voluson™ Signature 20 system is suitable for use in all establishments other than domestic, and may be used in domestic establishments and those directly connected to the public low-voltage power supply network that supplies buildings used for domestic purposes, provided the following warning is heeded: Warning : This equipment/system is intended for use by healthcare professionals in a professional healthcare environment only. This equipment/system may cause radio interference or may disrupt the operation of nearby equipment. It may be necessary to take mitigation measures, such as re-orienting or relocating the Voluson™ Signature 18 / Voluson™ Signature 20 system or shielding the location.
IEC/EN 61000-3-2 Harmonic emissions	Class A	
IEC/EN 61000-3-3 Voltage fluctuations/ flicker emissions	Complies	
<p>Note <i>The EMISSION characteristics of this equipment make it suitable for use in industrial areas and hospitals (CISPR 11 class A). If it is used in a residential environment (for which CISPR 11 class B is normally required) this equipment might not offer adequate protection to radio-frequency communication services. The user might need to take mitigation measures, such as relocating or re-orienting the equipment.</i></p>		

Guidance and manufacturer 's declaration - electromagnetic immunity			
<p>The Voluson™ Signature 18 / Voluson™ Signature 20 system is intended for use in electromagnetic environment specified below. The customer or the user of the Voluson™ Signature 18 / Voluson™ Signature 20 system should assure that it is used in such an environment.</p>			
Immunity Type	Equipment Capability	Regulatory Acceptable Level	Electromagnetic environment - guidance
IEC/EN 61000-4-2 Electrostatic discharge (ESD)	± 8 kV contact ±2, ±4, ±8, ±15 kV	±8 kV contact ±2, ±4, ±8, ±15 kV air	Floors should be wood, concrete or ceramic tile. If floors are covered with synthetic material, the relative humidity should be at least 30 %.
IEC/EN 61000-4-4 Electrical fast transient/burst	± 2kV for power supply lines 100 kHz repetition frequency ±1kV for input/output lines 100 kHz repetition frequency	±2 kV for power supply lines 100 kHz repetition frequency ±1 kHz input/output lines 100kHz repetition frequency	Mains power quality should be that of a typical commercial and/or hospital environment.
IEC/EN 61000-4-5 Surge	± 0,5 kV, ± 1kV line to line ± 0,5 kV, ± 1 kV, ± 2 kV Line to earth	± 0,5 kV, ± 1kV line to line ± 0,5 kV, ± 1 kV, ± 2 kV Line to earth	Mains power quality should be that of a typical commercial and/or hospital environment.

Guidance and manufacturer 's declaration - electromagnetic immunity			
<p>The Voluson™ Signature 18 / Voluson™ Signature 20 system is intended for use in electromagnetic environment specified below. The customer or the user of the Voluson™ Signature 18 / Voluson™ Signature 20 system should assure that it is used in such an environment.</p>			
Immunity Type	Equipment Capability	Regulatory Acceptable Level	Electromagnetic environment - guidance
IEC/EN 61000-4-11 Voltage dips and interruptions	0 % UT; 0.5cycle, Phase: 0,45,90,135,180,225,270,315° 0 % UT; 1cycle, Phase: 0° 70 % UT; 25/30cycle, Phase: 0° 0 % UT; 250/300 cycle	0 % UT; 0.5cycle, Phase: 0,45,90,135,180,225,270,315° 0 % UT; 1cycle, Phase: 0° 70 % UT; 25/30cycle, Phase: 0° 0 % UT; 250/300 cycle	Mains power quality should be that of a typical commercial and/or hospital environment. If the user of the Model Voluson™ Signature 18 / Voluson™ Signature 20 system requires continued operation during power mains interruptions, it is recommended that the Model Voluson™ Signature 18 / Voluson™ Signature 20 system be powered from an UPS or battery option.
IEC/EN 61000-4-8 Power frequency magnetic field	30 A/m, 50/60Hz	30 A/m, 50/60Hz	Power frequency magnetic fields should be at levels characteristic of a typical location in a typical commercial and/or hospital environment.
NOTE: UT is the a.c. mains voltage prior to application of the test level			

Guidance and manufacturer 's declaration - electromagnetic immunity			
<p>The Voluson™ Signature 18 / Voluson™ Signature 20 system is intended for use in electromagnetic environment specified below. The customer or the user of the Voluson™ Signature 18 / Voluson™ Signature 20 system should assure that it is used in such an environment.</p>			
Immunity Type	Equipment Capability	Regulatory Acceptable Level	Electromagnetic environment - guidance
IEC/EN 61000-4-6 Conducted RF	3 Vrms at 0.15 MHz- 80 MHz, 80% AM at 1kHz 6 Vrms in ISM bans between 0.15 MHz - 80 MHz 80% AM at 1kHz	3 Vrms at 0.15 MHz - 80 MHz 6 Vrms in ISM bands between 0.15 MHz - 80 MHz 80% AM at 1kHz	
IEC/EN 61000-4-3 Radiated RF EM fields	3V/m 80MHz - 2.7GHz 80 % AM at 1 kHz	3V/m 80MHz - 2.7GHz 80 % AM at 1 kHz	
IEC/EN 6100-4-39 Radiated Fields in Close Proximity	134.2 kHz, PM 50% 2.1 kHz, 65 A/m 13.56 MHz, PM 50% 50kHz, 7.5A/m	134.2 kHz, PM 50% 2.1 kHz, 65A/m 13.56 MHz, PM 50% 50 kHz, 7.5 A/m	

Guidance and manufacturer's declaration - electromagnetic immunity			
The Voluson™ Signature 18 / Voluson™ Signature 20 system is intended for use in electromagnetic environment specified below. The customer or the user of the Voluson™ Signature 18 / Voluson™ Signature 20 system should assure that it is used in such an environment.			
Immunity Type	Equipment Capability	Regulatory Acceptable Level	Electromagnetic environment - guidance
IEC/EN 61000-4-3 Proximity fields from RF wireless communications equipment	385 MHz: 27 V/m, PM at 18 Hz 450 MHz: 28 V/m, FM at ±5 kHz deviation 1 kHz sine or PM at 18 Hz 710 MHz: 9 V/m, PM at 217 Hz 745 MHz: 9 V/m, PM at 217 Hz 780 MHz: 9 V/m, PM at 217 Hz 810 MHz: 28 V/m, PM at 18 Hz 870 MHz: 28 V/m, PM at 18 Hz 930 MHz: 28 V/m, PM at 18 Hz 1720 MHz: 28 V/m, PM at 217 Hz 1845 MHz: 28 V/m, PM at 217 Hz 1970 MHz: 28 V/m, PM at 217 Hz 2450 MHz: 28 V/m, PM at 217 Hz 5240 MHz: 9 V/m, PM at 217 Hz 5500 MHz: 9 V/m, PM at 217 Hz 5785 MHz: 9 V/m, PM at 217 Hz 50 % Duty cycle	385 MHz: 27 V/m, PM at 18 Hz 450 MHz: 28 V/m, FM at ±5 kHz deviation 1 kHz sine or PM at 18 Hz 710 MHz: 9 V/m, PM at 217 Hz 745 MHz: 9 V/m, PM at 217 Hz 780 MHz: 9 V/m, PM at 217 Hz 810 MHz: 28 V/m, PM at 18 Hz 870 MHz: 28 V/m, PM at 18 Hz 930 MHz: 28 V/m, PM at 18 Hz 1720 MHz: 28 V/m, PM at 217 Hz 1845 MHz: 28 V/m, PM at 217 Hz 1970 MHz: 28 V/m, PM at 217 Hz 2450 MHz: 28 V/m, PM at 217 Hz 5240 MHz: 9 V/m, PM at 217 Hz 5500 MHz: 9 V/m, PM at 217 Hz 5785 MHz: 9 V/m, PM at 217 Hz 50 % Duty cycle	Portable RF communications equipment (Including peripherals such as antenna cables and external antennas) should be used no closer than 30cm (12inches) to any part of the this system, including cables specified by the manufacturer. Otherwise, degradation of the performance of this equipment could result. Minimum separation distances for higher IMMUNITY TEST LEVELS shall be calculated using the following equation: $E = \frac{6}{d} \sqrt{P}$ Where P is the maximum power in W, d is the minimum separation distance in m, and E is the IMMUNITY TEST LEVEL in V/m.
Info	These guidelines may not apply in all situations. Electromagnetic propagation is affected by absorption and reflection from structures, objects, and people		

Test frequency (MHz)	Band	Service	Modulation	Maximum power (w)	Distance(m)	IMMUNITY TEST LEVEL(V/m)
385	380-390	TETRA 400	Pulse modulation 18 Hz	1.8	0.3	27
450	430-470	GMRS, 460, FRS 460	FM ± 5 kHz deviation 1 kHz sine	2	0.3	28
710	704~787	LTE Band	Pulse modulation 217Hz	0.2	0.3	9
745		13,17				
780						
810	800-960	GSM 800/900, TETRA 800,	Pulse modulation 18 Hz	2	0.3	28
870		iDEN 820, CDMA 850,				
930		LTE Band 5				
1720	1700~1990	GSM 1800; CDMA 1900;	Pulse modulation 217 Hz	2	0.3	28
1845		GSM 1900; DECT;				
1970		LTE Band 1,3,4,25; UMTS				

Test frequency (MHz)	Band	Service	Modulation	Maximum power (w)	Distance(m)	IMMUNITY TEST LEVEL(V/m)
2450	2400~2570	Bluetooth, W LAN, 802.11 b/g/n, RFID 2450,LTE Band 7	Pulse modulation 217 Hz	2	0.3	28
5240	5100~5800	W LAN 802.11	Pulse modulation 217 Hz	0.2	0.3	9
5500		a/n				
5785						

Table 2-6 Test specifications for IEC/EN 61000-4-3 proximity fields from RF wireless communications equipment

2.14 Network Disclosure

Purpose and scope

This disclosure is intended to satisfy the requirements of IEC 60601-1 and IEC/ISO 80001-1 for disclosure of network-related specifications, requirements and residual risks in order to facilitate the responsible organization's risk management activities (e.g. pursuant to 80001-1) for their networks incorporating the Voluson™ Signature 18 / Voluson™ Signature 20 system.

Purpose of the network connection

The connection options (USB, Ethernet, WLAN, Bluetooth...) provide a possibility for data transfers from and to the Voluson™ Signature 18 / Voluson™ Signature 20 system. This allows the customer to use a convenient database system for data management and data sharing e.g. within a hospital or any other relevant organizations. Also simple standard device connections, such as printers, USB storage devices or similar, are provided by the USB connection for data exchange. Email can be used to conveniently transfer data.

Network interface technical specifications

Physical and link layer interface:	Ethernet IEEE 802.3 10BASE-T, 100BASE-TX and 1000BASE-T
Internet Protocol Version:	IPv4, IPv6
IP-Addressing:	static or DHCP

Wireless LAN (WLAN) Specifications

The Wireless LAN (WLAN) supports the following network protocols:

Standards:	IEEE 802.11 a/b/g/n/ac
Security Features:	WEP, WPA/WPA2, WPA-PSK/WPA2-PSK
Modulation Technology:	DBPSK, DQPSK, CCK, OFDM, 16-QAM, 64-QAM, 256-QAM
Frequency:	2.4GHz and 5GHz

Required IT network characteristics and configuration

Minimum throughput 100 Mbit/sec, recommended 1Gbit/sec for large image file transfer

Enabled Host-to-Host communication protocols:

Ports open to Internet:

- 443 - Insite ExC - GE HealthCare remote service (data transfer is encrypted) - transfer via proxy possible
- 443 - Fleet Management AVURI - Optional connection to backup/upload and download/ restore system configuration (data transfer is encrypted)

Ports open only to secure LAN closed to Internet:

- 53 – DNS Client
- 68 – DHCP Client
- 104 – DICOM send - port configurable on the system
- 137,138,139, 445 – SMB/Netbios for access to file shares and printers
- 514 (UDP), 601 or 6514 - syslog - port and encryption configurable
- 389 or 636 - Lightweight Directory Access Protocol - LDAP - port and encryption configurable on the system

Ports open to the Internet or local network depending on the configuration:

- 25, 465 or 587 - Simple Mail Transfer Protocol - SMTP port and encryption configurable on the system
- 123 - NTP Client

Listening Ports on the ultrasound system; only to secure LAN closed to Internet:

- 104 - DICOM receive - port and encryption configurable on the system

Note *For the DICOM Conformance Statement and the IHE Integration Statement please contact your local sales or service representative.*

Information flow between, the IT network and other devices on the IT network; intended routing through the IT network

- Receipt of patient demographics from DICOM Modality Worklist within the hospital network
- Sending of images and structured reports to PACS system (DICOM store) within the hospital network
- Receipt of images from PACS (DICOM Query/Retrieve) within the hospital network
- Export of images and cine clips to network share within the hospital network
- Backup and restoring of image data to a network share within the hospital network
- Sending of images and report data via Email via hospital SMTP server or SMTP server in the internet
- Access to GE HealthCare remote service via Internet

Potential hazardous situations resulting from failures of the IT network

The following general hazardous situations have been identified as potentially arising as a result of the IT network failing to provide the required characteristics specified above:

- Delayed or impaired access to images or other exam information or patient data.
- Permanent loss of images or other exam information or patient data.
- Corruption of images or other exam information or patient data.

In addition to the hazardous situations identified above, connection of the Voluson™ Signature 18 / Voluson™ Signature 20 system to a network that includes other equipment could result in other unidentified risks to patients, operators or third parties. The responsible organization should identify, analyze, evaluate and control these risks on an ongoing basis including after changes to the network such as those listed below, which could introduce new risks and require additional analysis.

- changes in network configuration
- connection of additional items to the network
- disconnection of items from the network
- update of equipment connected to the network
- upgrade of equipment connected to the network

In order to reduce the vulnerability of the system with respect to attacks from the internet, it is not recommended to directly connect to the public internet. Note that when using the UMTS terminal the provider usually acts as a filter to the public internet. The upload of data to an internet-based service requires an internet connection between the ultrasound system and the internet-based server. It is strongly recommended to use a firewall to restrict network access from and to the ultrasound system when features requiring internet access (e.g. service remote access and Email) are installed. Other precautions like a secure network segment are encouraged. It is the user's responsibility to ensure a secure internet connection, e.g. to prevent patient data leaks.

2.15 Cybersecurity Note

Since the Voluson systems are integrated into your IT-network, GE HealthCare wants to make sure that you are aware of the proactive measures we are taking to secure the systems. Below are measures we have implemented to secure the Voluson systems.

- The operating system is locked down to prevent a user from loading software, opening email, or using a web browser and introducing viruses or Trojan horses to the system.
- All operating system services that are not used by the system software are disabled to help ensure that the source of security vulnerabilities is minimized.
- Disable, or make inaccessible, functionality that is typically used as malware vectors for spreading viruses (e.g. email services, web browsers).
- The “auto run” feature is disabled on the system. For instance, when a USB memory stick that has a program that runs automatically is inserted, the system will not open or run the program.
- Close network entry points that are not in use by the Voluson scanner software by strict firewall configuration and by disabling Services. The only Internet connection needed is an outbound port to GE HealthCare’s remote service platform (InSite™ ExC) and AVURI, which is only opened on request by the user and through a secure HTTPS connection (port 443). Inbound connections are used for DICOM connectivity only (port 104, configurable) within the local network .
- To control scanner access the system offers a built-in user management that can be configured individually by the device administrator. This user management can be linked to a central user management system (LDAP/AD).
- Use secure integration and communication between systems (Scanners, Workstations and Servers).
- Enable encryption of patient data stored on the internal hard drive to ensure confidentiality.
- Monitor public security bulletins from software vendors and news services, analyze for applicability to the Voluson scanner, and include third party software security patches as necessary within GE HealthCare software.
- Release GE HealthCare Ultrasound validated software or use other measures as necessary to resolve or mitigate product vulnerabilities.
- Assess potential vulnerabilities of our systems using up-to-date commercially available vulnerability scanning tools. Identified vulnerabilities are mitigated as appropriate based on risk assessment of the product.
- As an additional layer of protection against malware GE HealthCare offers a Whitelisting solution with the latest generation of Ultrasound scanners. This ensures that only approved software is executed on the device.

We believe that this Defense in Depth strategy using the combination of the security measures above and the security standards of Microsoft’s® Windows® 10 IoT will provide security against malware, especially for a system used in a professional, hospital grade networking environment that itself should provide a high level of security measures.

Finally, a few points why we (as well as all other manufacturers of PC-based medical Ultrasound devices) do not use Anti-Virus software: Commercial Anti-Virus software is commonly used on general-purpose computers to detect the presence of malicious software (e.g. virus, Trojan horse, worm). Anti-Virus software is useful on general-purpose computers as they typically cannot be sufficiently hardened against the attack vectors used by malicious software.

GE HealthCare has chosen the approach of Whitelisting to provide additional protection against malicious software. The Voluson ultrasound systems however are single purpose (dedicated) devices, not intended to execute arbitrary programs or applications. The Whitelisting solution will prevent the execution of any unknown and unintended software on the ultrasound device.

Note

For specific and detailed information related to privacy and security, please consult the Privacy & Security Manual (Voluson™ Product Privacy & Security Documentation).

How to contact GE HealthCare

For privacy and security concerns regarding GE HealthCare products, visit :
<https://www.gehealthcare.com/security>

2.16 Service Software – Remote Access

By using the remote access feature, a GE HealthCare field engineer can access the ultrasound system via a network connection. The field engineers are required to contact/call the affected site in advance prior to establish a connection to the system.

Disruptive Mode:

If the field engineer requires unrestricted access to the ultrasound system the field engineer requests to create a disruptive mode on the system. A message appears on the screen asking for permission to switch to disruptive mode:

GE HealthCare Service is requesting permission to diagnose the system remotely. Normal system operations might be disturbed during this period. Click on YES to allow GE HealthCare Service to continue system diagnostics.

If disruptive mode is accepted, work on the system can be severely affected. Therefore, it is not allowed to perform an exam or make a diagnosis using the ultrasound system while being in disruptive mode.

Note

A remote connection can affect the system's performance (e.g., in 3D/4D or Doppler mode). Therefore, it is recommended to cease work on the system as soon as the field engineer contacts the site and announces the remote connection.

2.17 Software upgrade (eDelivery)

Software upgrade for the unit may become available for download and installation through the GE HealthCare Service platform. When a software upgrade is available a message icon is displayed on the status bar.

- Note** *Software upgrade through the GE HealthCare service platform may not be available in all markets.*
- Note** *For further information please refer to the Voluson™ Signature Series Service Manual.*
- Info** *Please contact a GE ULTRASOUND KOREA, LTD. service technician for further assistance.*

Software download and installation

1. Press the standby button on the user interface.
The Shut Down dialogue window with the software **Download** button is displayed.
2. Press **Download**.
The download process is started. The progression of the download process is displayed. Download may be paused and can be resumed later.
3. When the software download is completed, the **Download** button changes to **Install**. Software installation may take about one hour.
4. Press **Install**.
The system reboots automatically and the installation process is started. Do not interrupt the installation. The system may reboot automatically several times during installation or you may be prompted to restart the system.
When the installation is complete, the New Software Verification window is displayed.
5. Perform a check for all features listed. Move the cursor over the feature name to get information on how to check each feature.
If all features are **OK** the signature field is enabled.
6. Enter your signature and press **Send**.
The system is ready.
If one feature gets “Failed”, the user will be prompted to reload the original software.

2.18 System Messages

High system temperature

In case the temperature of the system is higher than usual, the following message is displayed on the monitor screen. You can select the language in which the message is displayed.



Caution

- High system temperature reached! Further use of the system is possible. If this message persistently appears, please contact your service agent.
- High system temperature reached! If the system temperature stays high, the system will shut down within 10 minutes.

Note

If the system needs to shut down, an additional message is displayed in the message area of the monitor screen:

High system temperature - system shutdown within [] minutes!

System Date and Time

In case the Date and Time of the system are incorrect due to a CMOS power failure (e.g. a drained or defect CMOS battery) the following message is displayed on the monitor screen. You can select the language in which the message is displayed.



Caution

- Please set the correct date & time. To correct this issue please contact your service agent.

USB device issue

In case a USB device issue occurs that makes the system unresponsive, the following messages will be displayed on the monitor screen:



Caution

- USB device issue detected. Attempting to recover/reconnect. Hint: Safe USB device removal: "Eject Media/F3" → "Stop Device".
- USB device issue detected. System shutdown within [5] minutes! Hint: Safe USB device removal: "Eject Media/F3" → "Stop Device".

Note

If reconnecting is not successful, an additional message is displayed in the message area of the monitor screen:

USB device issue detected. System shutdown within [] minutes! Hint: Safe USB device removal: "Eject Media/F3" → "Stop Device".

This page was intentionally left blank.

Chapter 3

System description

<i>Overview</i>	3-2
<i>The system</i>	3-3
<i>The user interface</i>	3-5
<i>The monitor</i>	3-13

3.1 Overview

The Voluson™ Signature 18 / Voluson™ Signature 20 system is a professional, innovative, most versatile real-time scanning system.

It opens new sonographic possibilities with the 3D/4D volume scanning technique. The vast array of probes makes it suitable for many clinical applications. The system is designed for follow-up expansion.

The Voluson™ Signature 18 / Voluson™ Signature 20 system is delivered with recommended basic settings for a variety of clinical applications. Depending on the user's experience the default settings can be changed and stored as new User Programs.

Diagnostic possibilities

The availability of image acquisition modes depends on the selected probe.

- 2D Mode
- 3D/4D Mode
- Additional Operating Modes (B-Flow, XTD-View)
- M Mode (M+Color Flow Mode)
- Spectral Doppler (Pulsed- and Continuous Wave)
- Color-Doppler (Velocity-, Power-, Tissue imaging and HD-Flow™)

Operable probes

- Multi-element probes (linear array, curved array and phased array)
- Real Time 4D Volume probes

The operation is designed for the specific clinical requirements and ensures simple and efficient handling. Vast ranges of measuring and evaluation programs, as well as many special functions enable comfortable working. The interface with interface software provides quick digital archiving of images and/or volume data sets on mass storage medium. A network interface (Ethernet) provides documentation in DICOM standard.

Optional peripheral devices

For more information see 'Peripherals and Hardware' on page 12-5.

Software and hardware options

For software and hardware options refer to the price list of the Voluson™ Signature 18 / Voluson™ Signature 20 system.

3.2 The system

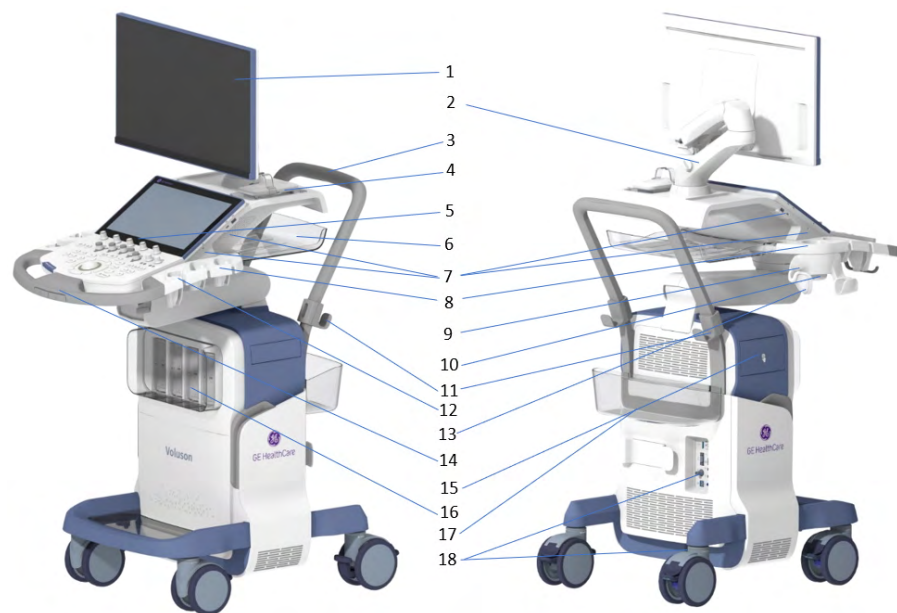

Figure 3-1 System description

1. 23.8 inch widescreen monitor
2. Monitor arm
3. Rear handle
4. Wireless probe charge holder (option)
5. Control panel with touch panel display
6. OPIO rear tray (option)
7. USB port (2 A types, 2 C types), Microphone
8. Probe Holder
9. Horizontal TV probe holder (option)
10. Gel holder or Gel warmer (option)
11. Rear handle cable hook (option)
12. Vertical probe holder insert (option)
13. TV probe holder insert (option)
14. Front handle with control panel swivel and updown button
15. BW printer (option) or Drawer (option) bay
16. Probe connectors
17. Rear basket (option)
18. External I/O connectors and Mains power switch

Applied parts

Applied parts of the Voluson™ Signature 18 / Voluson™ Signature 20 system are the following parts/ surfaces:

- The contact surface of the ultrasound probes to the patient (the transducer window for transmitting ultrasound and the immediate surrounding housing material).

- The ECG contact pads (if ECG option is used).

3.3 The user interface

	
<ol style="list-style-type: none"> 1. ON/OFF standby power button 2. Touch panel screen 3. Touch panel rotary/push/flip controls 4. Mode controls 5. Customer programmable keys 6. Voluson naming plate 7. User interface swivel button 8. Zoom/Depth and Angle/Focus rotary/push controls 9. Remote control P-keys (programmable) 10. Freeze/Run key 11. Trackball and Trackball keys 12. User interface up down button 13. Task lamp button 	

Table 3-1 User Interface

3.3.1 User interface adjustment

Swiveling the user interface (UI)

1. Grab the UI handle with 2 hands.
2. Press the UI swivel button on the user interface handle.
3. Swivel the UI and adjust the angle.
4. Release the UI swivel button.

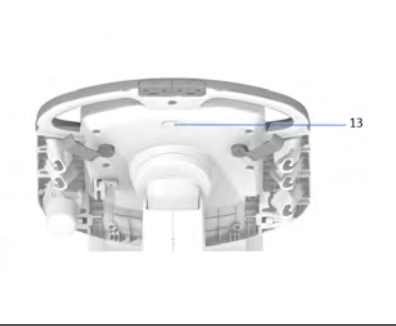
Adjusting the user interface in height

1. Grab the UI handle with 2 hands.
2. Press the UI up/down button on the user interface handle.
3. move up or down the UI with grabbing handle.
4. Release the UI up/down button to fix the desired UI height.

3.3.2 The touch panel

Each mode menu is divided into a **Main Menu** and **Sub Menu** and only shows buttons which are available for the selected probe and image acquisition mode.

Info *The touch panel can be blocked by direct sunlight, by objects or coupling gel. Clean the touch panel regularly according to instructions. Avoid direct sunlight.*

Hint *If no ultrasound probe is selected, the Probe Select menu appears. Select a probe, an application and a preset.*

Sample menu

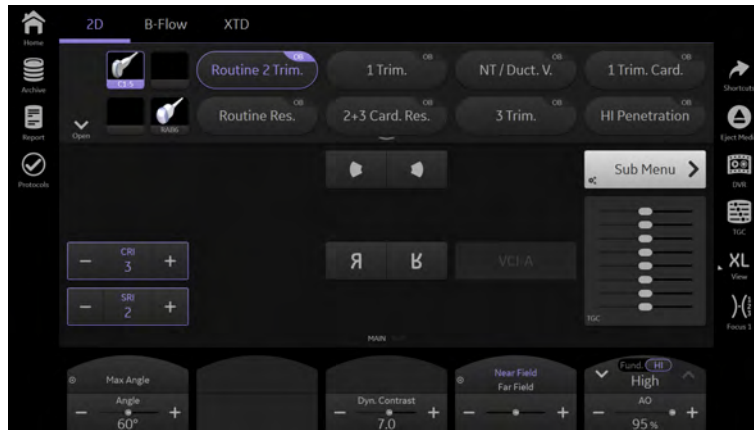

Figure 3-2 Sample touch panel menu

Location	Available controls
Top	Mode selection (2D, B-Flow, ...)
Left	General menu (patient, archive, ..)
Center	Touch panel buttons according to the selected mode, including ultrasound probe and preset
Right	Shortcuts, media control, TGC menu, XL View options

Customization of the touch panel

It is possible to customize the main panel controls in the **Main Menu** and **Sub Menu** menu as desired.

1. A long press onto the **Main Menu** or **Sub Menu** button opens a pop-up menu for selecting **Configure** or **Back to default**.
 - **Configure** enables the configure mode (blue frame appears) for moving controls to the desired position.
 - **Back to default** restores each control positions to the factory default position.
2. Either drag and drop the control to the desired position or move it over an already existing control to exchange the position of the two controls. It is also possible to move controls from or to the **Main Menu / Sub Menu**.
3. To exit the edit mode, tap anywhere outside the edit area or press a hardkey. The edit mode is disabled automatically after 10sec of user inactivity.

All possible modes and probe depending controls are displayed in customization mode.

3.3.3 Button description









This chapter lists available buttons on the user interface and touch panel.

3.3.3.1 User interface controls

The user interface



User interface controls

Power / Standby		Switches the system on and into standby. Located at the left side of the user interface touch screen. Login/off is available.
UI Adjustment		Height adjustment of the user interface.
UI Movement		Horizontal movement of the user interface.
Patient Data		Opens and closes the patient data screen.
End Exam		Ends an exam.
Exit		Exits a mode.
Pointer		At the first push an arrow shaped cursor appears for menu and image operations. A second push turns it off.
Abc		Activates the annotation function in order to add comments to an image and shows the indicator and Body Mark menu in a submenu on touch panel.

Auto



Auto Optimize (**Auto**) lets you optimize the image based upon the actual B-Mode image data. It functions as a pre-/post-processing picture analysis system. Press **Auto** once to activate it (green or theme color) and once again to update the optimization.

- In 2D images (B, BF, CFM,...) the grayscale (gamma curve) is optimized and the contrast rises. Therefore a histogram of the central 81% (ROI) of the scan area is analyzed. The ROI depends on the probe, scan depth and opening angle.
Additionally the Auto-TGC optimizes the B-gain value and the slider gain values in the running B-image. Double click to reset the sliders to middle position and the gain to user program values in scan mode.
- In spectral Doppler images (PW, CW) the baseline and the PRF are optimized. The spectrum is shifted into the middle, the PRF automatically detects the highest flow velocities and adjusts according to it. To restore the previous values, double click.
- In spectral Doppler images (PW) the WMF is optimized. The WMF filters the low velocity portions of the spectrum. To restore the previous values, double click. The WMF is additionally adjusted to baseline and PRF.
- In 3D/4D volume images the **Auto** button can activate or deactivate SonoRenderlive to optimize the image visualization.
- The **Autolive** optimizes the gain value in the 2D running image

Note *The availability of **Auto TGC** and the **Auto TGC Brightness** and **Autolive** can be customized in the System Setup.*

The Auto-TGC optimization status (On/Off) is displayed in the Image Info with an asterisk (*):

- On: as soon as an optimization process is started, the status is set to On. The Gain value is marked with an asterisk.
- Off: the status is set to Off when an optimized TGC value is changed manually or by a preset function. The Gain value is displayed without asterisk.

The Autolive status (ON/Off) is displayed in the Image Info with an icon :

- On: The status is set to On when **Autolive** is activated. The icon is displayed in the Image Info.
- Off: The status is set to Off when entering in freeze or pressing **Auto** once again. The icon in the Image Info disappears.

Clear



Removes graphics, measurements and annotations.

Measure



Opens the Measurement and Calculations menu.

2D



Opens the 2D menu.

3D



Opens the 3D menu.

4D



Opens the 4D menu.

Format dual



















Display format to show two or three (toggles in between) images on the monitor display.

Format quad



Display format to show four images on the monitor display.

Format single		Display format to show one image on the monitor display.
P1 - P4	 	Print keys to be programmed as desired.
C1 - C4	 	Configurable keys to be programmed as desired.
Freeze		Freeze and unfreeze/run the image.
X, Y, Z rotation /Parallel Shift	 	X, Y and Z rotation / Parallel Shift.
PW		Opens PW-Mode.
M		Opens M-Mode.
PD		Opens PD-Mode.
C		Opens Color Mode.
Zoom		Two different zoom functions are available: Press the zoom button to use HD Zoom or Pan Zoom, rotate the according control to use Pan Zoom.
Angle		This function changes the image angle.
Focus depth		This function changes the focus depth.
Depth		Depth controls the distance over which the B-Mode images anatomy. To visualize deeper structures, increase the depth. If there is a large part of the display which is unused at the bottom, decrease the depth.
Trackball		Trackball with 8 Trackball buttons.

3.3.3.2 Home menu controls



Opens the **Home** menu on the touch screen and the monitor.

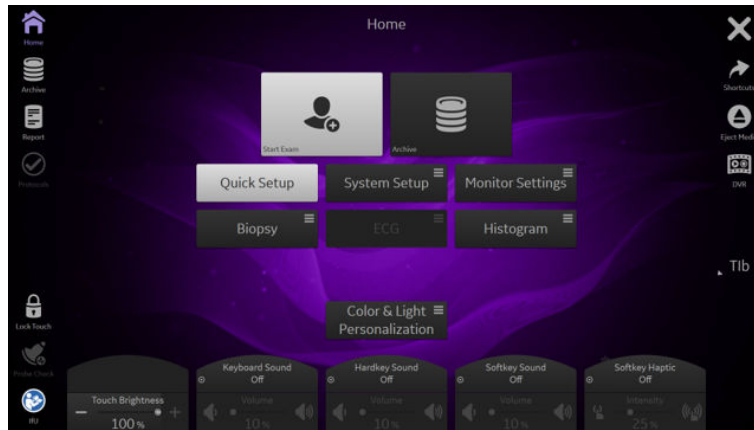

The **Home** menu offers a selection of basic functions:

- Press  to open the index file from the Instructions for Use USB or a connected USB storage. If no media or incorrect media is inserted, a message to enter the correct media appears.
- **Start Exam**: Press this button to start an exam.
- **Archive**: Press this button to open the **Archive**.
- **Quick Setup**: Press this button to open the **Quick Setup**.
- **System Setup**: Press this button to open the **System Setup**.
- **Monitor Settings**: Press this button to change the **Monitor Settings**.
- **ECG Menu**: Press this button to open the **ECG Menu**.
- **Histogram**: Press this button to open the **Histogram**.
- **Color & Light Personalization**: Choose the Color and Brightness of **Ambient**, **Operating Panel** and **UI Theme**
 - **Ambient**: Select the desired Ambient color.
 - **Ambient Light Brightness**: Adjust the brightness of the Ambient background lights.
 - **Operating Panel Color**: Select the desired hardkey and trackball color
 - **Hardkey Brightness**: Adjust the brightness of the hardkey background lights.
 - **Trackball Brightness**: Adjust the brightness of the trackball background lights.
 - **UI Theme**: Select the desired UI Theme color.
- **Lock Touch**: Lock the Touch panel for cleaning purpose. Leave the cleaning mode with **Exit**.
- **Probe Check**:

Note *This button is only enabled in 2D mode. The button is disabled if no probe is active. During the test, it is not possible to continue working. (Interactions on Screen, Touch Panel or Hard Keys can be performed after finishing the test.)*

1. Press **Probe Check**.
 2. The Probe Check dialog appears with following text: "The lens surface or cap surface must be clean (e.g. free of dirt, water or coupling gel) to perform the test!"
 3. Press **Start Test** to continue or the button **Cancel** to abort.
 4. If the probe check passes a message with a green checkmark is displayed. If the probe check fails a message with a red x appears.
 5. Press **OK**, the dialogue closes and the device can be used again.
- **TI select**: Select the thermal index **Tib** or **Tic** to be displayed during a scan.

- **Biopsy:** Press this button to open the **Biopsy** menu.
- **Touch Brightness:** Change the overall brightness of the touch screen display.
- **Hardkey / Softkey Sound:** Change the **Volume** of the keys and turn them on or off (i.e. the volume of user interface sounds).
- **Keyboard Sound:** Change the **Keyboard Volume** or turn the sound on or off.
- **Softkey Haptic:** Change the Haptic intensity or turn the haptic on or off .
- **Join Voluson Club:** Opens the Voluson Club window (see below).
- **Show Home on Start-up:** If selected the **Home** menu appears after bootup.
- **Education:** Displays a preview of max. 3 education videos (max. 2 videos if the Learning Library showing and explaining basic functions of the US device is available). To see all videos, press **More education videos**. Tap onto a preview button to automatically open the video player and play the video. It is possible to play/pause the video, to jump to the previous/next video, to follow the video progress via slider and to select videos from the list available.

Note *It is possible to import videos (mp4 format) in the Service Tools menu.*

- **Exit:** Press this button to leave the menu.



Opens the **Archive**.



Opens the **Worksheet / Report** menu.



Ejects media devices, i.e. USB,....



Opens the **DVR** menu.



Opens **Protocols** with the list of **Scan Assistant** tools and lists. While using a protocol this button allows to open and close the actual protocol.



Press the button to lock the screen for cleaning. The display appears white and through cleaning (wiping over it) it turns black.

Feature specific controls are described in the corresponding chapters below.

Voluson Club

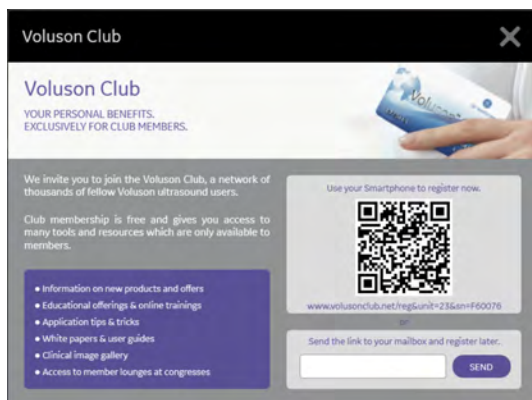

The QR Image contains the URL to the Voluson Club registration and the serial number of the Voluson™ Signature 18 / Voluson™ Signature 20 system.

Note *It may be necessary to install a QR App on your smartphone.*

If you want to register later, enter your email address and click **SEND**.

Note *Make sure to configure the email settings beforehand. For more information see 'Email Configuration' on page 11-32.*

3.4 The monitor

3.4.1 Monitor adjustment

Adjusting the monitor

The monitor can be moved forward and backward, adjusted in height and inclined.



Figure 3-3 Adjusting the monitor back and forth.



Figure 3-4 Adjusting the height of the monitor.



Figure 3-5 Adjusting the inclination of the monitor.

Securing the monitor for transport

1. Move the upper monitor arm parallel to the lower arm and push it down (A).
2. Rotate the monitor to the center position and turn the knob (B) counterclockwise until the arm rotation and height adjustment is locked.
3. Tilt down the monitor to lowest position.



3.4.2 Monitor Display

Display layout



Figure 3-6 Monitor display standard

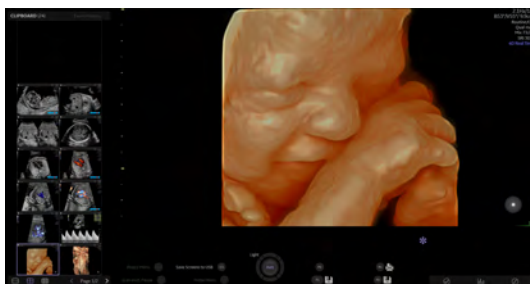

Figure 3-7 Monitor display XL



Figure 3-8 Monitor display fullscreen

Title bar

The title bar shows the corresponding logo of the device, patient, operator and exam information, probe and image information.

Image area

In this area all ultrasound imaging formats (single, dual, triple, quad, 3D) and all system setup windows are displayed.

Clipboard area

The clipboard is displayed in the left monitor area. It also includes the Exam History area if more previous exams are available.

Heads-up area

The heads-up area displays the currently used touch panel control, the current status of the trackball and the programmable Cx and Px buttons. It contains the freeze (gray) / run (green) icon , the cine bar(s) or a temporary progress bar. It also includes messages and warnings for the user.

Flexible Display area



















This area is used for different functionalities like on screen menus, listing of done measurements, the graphical display of OB graphs with current measurement values, the user guide with corresponding links and QR codes, scan protocols and others.























Footer area





Tapping/scrolling or pressing/rotating/flipping respectively allow the adjustment of values or turn functions on/off.

Connectivity area

Depending on settings and configuration the following icons are displayed in the Connectivity area:

Icon	Description
	Connect to GE HealthCare Clinical Lifeline: remote access inactive
	Connect to GE HealthCare Clinical Lifeline: access pending
	Connect to GE HealthCare Clinical Lifeline: remote access active
	Connection to service failed
	Network status: connected
	Network status: disconnected
	Network status: remote connection
	WiFi connected
	WiFi disconnected
	WiFi: remote connection
	Email status: not configured
	Email status: ok
	Email status: failed
	Microphone: on
	Microphone: muted
	Microphone: recording
	USB Icon available, Disc inserted <i>For more information see 'USB Recorder (DVR) - Optional' on page 12-11.</i>
	USB PLAY mode.

Icon	Description
	USB PLAY-PAUSE mode.
	USB REC mode.
	USB REC-PAUSE mode.
	USB status: busy.
	Software update available for download (eDelivery) A click on the symbol opens a pop-up menu. Choose between Download, More Info or Decline.
	Spooler: idle state
	Spooler: transfer failed
	Spooler: transfer in progress
	External monitor: enabled
	External monitor: disabled
	Device Management: not activated but option available
	Device Management: connected to the backup server, opens the System Setup Device Mgmt tab
	Device Management: optional backup is available for download, reload and while the download is in progress
	Device Management: backup upload is in progress
	Device Management: network connection failure (connection interrupted)
	Battery Warning
	Power Mode: AC power Plugged
	Battery Mode: 76% ~ 100%
	Battery Mode: 51% ~ 75%
	Battery Mode: 21% ~ 50%
	Battery Mode: 16% ~ 20%
	Battery Mode: 1% ~ 15%
	Vscan air probe battery: 0 ~ 10%

Icon	Description
	Vscan air probe battery: 11 ~ 25%
	Vscan air probe battery: 26 ~ 50%
	Vscan air probe battery: 51 ~ 75%
	Vscan air probe battery: 76 ~ 100%

Note A click onto the network connection icons opens the **Device Setup** dialog within the system setup if the current state of the system allows that. Otherwise a message appears.

Note A click onto the WiFi connection icon opens the Wireless Networks dialog displaying all available WiFi networks. Select the desired network to connect with, enter the network security key, define whether to connect automatically when the network is available and enable/disable the WiFi radio as desired. Press **Show Details** to receive more information about the network. Press **Setup** to enter the more detailed WLAN configuration within the system setup.

Note A click onto the DVR/USB icons opens the **Eject Media** menu.

Note While recording, the red dot flashes. Same flashing is visible if a P or C-Key is assigned with the DVR recording function.

Note A click onto the service icons opens a popup window. Select between **Disconnect**, **Connect Clinical Lifeline** and **Connect To GE Healthcare**.

Bootup Screen

The bootup screen contains the "Consult accompanying documents" icon and the boot progress bar on the main screen and copyright text on the touch screen.

Activate Windows

In case of network connectivity issues, it may not be possible to activate your Windows® operating system (see image below). Please contact your local IT department to make sure that inside your local network infrastructure activation servers of Microsoft® are reachable. If needed, please contact your GE HealthCare service technician for further support.

Note When present, the "Activate Windows" message will not impact system performance in any way.

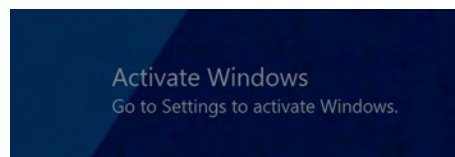

Measurement Result Window

The Measurement Result Window is opened by pressing the graph icon at the bottom of the flexible display area. If selected, the Measurement Result Window is also open when a new exam is started.

It is always available without any restriction, independent of exam application or measurement application. All OB measurements and the calculated ratios can be displayed.

The intended use of the Measurement Result Window is:

- to show done measurements of the current exam in a short form. The short form reflects an extract of the measurement report.
- to show the corresponding graph with the current measurement and if configured with measurements from previous exam(s), keyword "Trending".
- to show a user defined graph after the measurement.

The Measurement Result Window displays a list of "Calc" measurements (max. 15). Each fetus has its own Measurement Result Window with the measurements, values, deviation intervals and age listed.

Additionally an OB graph can be displayed according to the Measure Setup. When the system cursor is moved over a measurement result, the measurement row is highlighted and the corresponding graph appears.

After a measurement is finished the data is updated in the Measurement Result Window.

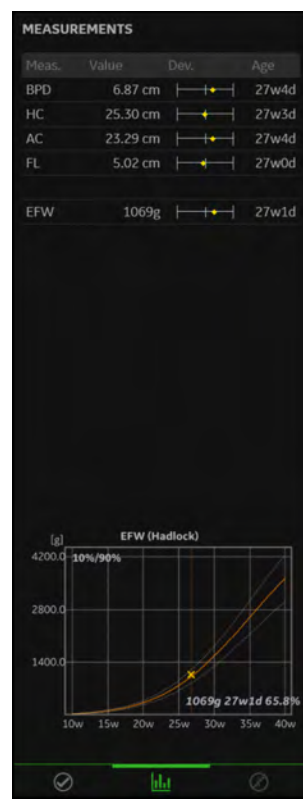

Figure 3-9 Measurement Result Window

Chapter 4

Getting started

Powering the system ----- 4-2
Getting started ----- 4-5
Basic operations ----- 4-8

4.1 Powering the system



Caution

Installation and initial start-up of the system must be performed by authorized service personnel.

Note *Read all safety precautions before using this system.*

Power on

1. Read 'Electric Installation' on page 2-14 before powering on the system.
2. Connect the AC Mains Power Cable to a hospital grade power receptacle with the proper rated voltage.
3. Switch ON the AC Mains switch at the rear of the system.
4. To switch on the system, press the Standby button located at the left side of the touch panel.
5. The system should now go through its boot-up process with no further user intervention (approximately 2 minutes).
6. After initialization is complete, the default 2D Mode screen is displayed with the selected probe. *For more information see 'Getting started' on page 4-5.*

Power off

1. Press the Standby button located at the left side of the touch panel and select shutdown in the dialog box.
2. After the system is fully powered off, you may switch off the AC Mains circuit breaker located at the rear panel of the console.

Info

- *In case of no system reaction, keep the standby button pressed for 5 seconds.*
- *After shut down, wait for at least 10 seconds before restarting the system again.*
- *In the console's standby mode, the B/W printer remains supplied by power indicated by a green light. The B/W printer can be switched into standby by its own standby switch. In the console's standby mode, the electric lift remains supplied by power. Hence, for convenience the height of the user-interface can be adjusted (up/down and swivel left/right/forward/backward) also in standby mode.*
- *Double-click the standby button to immediately shutdown the console.*

Shutdown dialogs

The shutdown dialogs can vary depending on the processes that may be active.

1. Normal shutdown options
 - **Shut down**
 - **Restart**
 - **Cancel**
2. If a software upgrade is available, a **Download** button is displayed. *For more information see 'Software upgrade (eDelivery)' on page 2-48.*
3. If remote service is running or image data is being transferred, a message will be displayed to inform the user that shutdown or restart is not recommended.

4. If a process is running that cannot be stopped, the user will be informed that shutdown is not possible.
5. If a Voluson Update is available, a **Voluson Update** button is displayed.
6. If a mandatory or optional backup is available, the backup is displayed.
 - If a mandatory backup is available, a message box appears informing that the downloaded backup will be loaded. A press onto **Restart** or **Shut Down** automatically loads the backup then.
 - If an optional backup is available, **Restart** or **Shut Down** only load the backup automatically if the corresponding option is checked, otherwise the backup is discarded.
 - If there are images in the Dicom Queue, a message is displayed.
 - If the user login is activated, there is the option to login/logoff.

Sleep Mode

Info *To use Sleep Mode when do a portable exam in order to reduce the time to start up the system.*

1. Press the Standby button on the user interface and select Sleep.
2. After the Standby button turns to amber color, you may unplug the power cable from the receptacle.
3. To wake up the system, press the Standby button briefly.

Info *The sleep mode is only able to be operated during scan mode. Can not be used while other windows are in use.*

Info *System will force **Shutdown** or **Restart** after 10 sleeps.*

Info *System can boot from sleep both connected and disconnected from AC power.*

Note *Sleep mode is available in battery mode and AC power mode. Once the battery runs out the system will not operate. To turn on the system, the user needs to connect the AC power. The sustaining time of sleep mode will be reduced due to the battery capacity being decreased by the number of usage.*

Note *Use the Sleep mode when the battery capacity is sufficient. Otherwise, unexpected problems may occur.*

Hibernate Mode

Info *To use Hibernate Mode in order to reduce the time to start up the system.*

- **Fast Startup enabled (Restart not affected):** Activate **Hibernate Mode** (Default: unchecked)

1. Press the ON/OFF standby power button on the Control Console. The Shut Down dialogue window is displayed.
2. Marked with a check in the checkbox **Fast Startup enabled (Restart not affected)**.
3. After the ON/OFF standby power button turns to amber color, you may unplug the power cable from the receptacle.
4. To wake up the system, press the ON/OFF standby power button briefly.

Info *System will force **Shutdown** or **Restart** after 9th boot up from Fast startup enabled.*

Info *System can boot from Hibernate mode both connected and disconnected for AC power but in case of AC power disconnected, battery must be connected.*

Note *Hibernate mode is available in battery mode and AC power mode. Once the battery runs out the system will not operate. To turn on the system, the user needs to connect the AC power. The sustaining time of Hibernate mode will be reduced due to the battery capacity being decreased by the number of usage.*

Note *Use the Hibernate mode when the battery capacity is sufficient. Otherwise, unexpected problems may occur.*

4.2 Getting started

Connecting a probe

1. Plug the probe connector into a free socket.
2. Turn the probe lock-lever to vertical position. Ensure that the probe sits tight.
3. Place the cable and the probe in the provided holder.

Selecting a probe

1. The connected probes appear on the touch panel.
2. Touch the desired probe. The touch panel button turns green.
3. Select an application folder.
4. Select a preset.
5. The 2D Main Menu appears on the touch panel.
6. Perform the scan.

Disconnecting a probe

1. Freeze the image by pressing **Freeze**.
Do not disconnect an active probe. Before disconnecting the probe, open the Probe Selection menu and select a different probe.
2. Turn the probe lock-lever to horizontal position and remove the probe.

Entering patient data

1. Press **Patient Data** on the user interface.
2. Insert first and last name of the patient.
3. Select the desired exam category (application).
4. Enter additional patient data.

Changing the user presets

The Probe/Preset Select Menu contains all connected probes with their according connector letters. To quickly select a probe or a preset tap onto it. To open the full probe menu touch the chevron or swipe the menu down. Here it is possible to select the desired probe, application/exam and preset or to edit presets and save them.

1. Select **Save as Preset**.
2. Select an empty preset button and enter a preset name. Then hit **Save & Exit**. The new preset is created.

Note *It is also possible to save the preset in other application/exam folders or to create a new folder. By touching an empty spot the system automatically allows to name the new folder. Renaming of existing folders is also possible by simply touching onto them.*

Current presets can be overwritten:

1. Select **Save** to overwrite.
2. Select the existing preset button to be overwritten. Rename the preset if desired and hit **Save & Exit**. A message asking whether to overwrite the preset (**Yes**) or not (**No**) appears.

Saving 3D/4D acquisition presets:

1. Modify the preset as preferred.
2. Execute to acquire a 3D/4D dataset with the new settings.

3. Go to the **Render** menu and select **Save** to overwrite or **Save as** to create a new preset.

Saving 3D/4D render presets:

1. Modify the 3D/4D render after acquiring a 3D/4D dataset.
2. Select **Save** to overwrite or **Save as** to create a new preset

Note *It is also possible to save the preset in another folder. Therefore a new folder has to be selected and (re)named.*

Note *To overwrite a preset in any of the situations described above it is also possible to program a C-Button as **Save Presets** or to use the shortcut menu to execute **Save Presets**.*

Note *When presets containing lung/ophthalmic artery settings are saved or changed, the corresponding limits are kept.*

Info *For more information see 'Imaging Presets' on page 11-51.*

Activating modes and calculations

The buttons for modes and calculations are located on the user interface. Active buttons are highlighted green.

- Press **2D** to start B-Mode.
- Press **C** to start Color Flow Mode and Tissue Doppler Mode.
- Press **M** to start M-Mode.
- Press **PD** to start Power Doppler Mode and HD Flow.
- Press **PW** to start Pulsed Wave Doppler Mode.
- Press **3D** to start static 3D scanning.
- Press **4D** to start real-time 4D scanning.
- Press **Calc** to access different measurement packages and generic measurements.

3D/4D scanning

1. Select a 3D/4D volume probe.
2. Optimize specific structures by using the available presets.
3. Adjust the size and position of the ROI Box (Region of Interest) by pressing **Change** (top trackball key). Press **Change** again to set the size.
4. Adjust the volume acquisition angle by flipping either the **Vol.Angle** or **VolAngle** switch up and down or by pressing the up/down chevrons on the touch panel next to either **Vol.Angle** or **VolAngle**. The Volume Angle is displayed on the touch panel footer and on the right lower corner of the monitor..
5. Start the volume acquisition by pressing **Start** (right trackball key) or **Freeze**.

Info *For more information see Chapter 8.*

Using the Freeze button

1. Press **Freeze** to freeze the image.
2. Pay attention to new functions available in Freeze Mode, such as new trackball functions.
3. Press **Freeze** again to continue live image data acquisition.

P-buttons

The **P1**, **P2**, **P3** and **P4** buttons are assigned with default functions. The assigned function is displayed at the lower, right-hand section of the monitor display.

C-buttons

The **C1**, **C2**, **C3** and **C4** buttons are assigned with default functions. The assigned function is displayed at the lower, left-hand section of the monitor display.

Trackball

The trackball can be moved like a computer mouse. It is surrounded by the trackball buttons. The function of each button depends on the activated and on the current image acquisition mode. The assigned function is displayed at the lower, center section of the monitor display.

Electronic Instructions for Use

Consult the electronic Instructions for Use for help. To change the language of the Instructions for Use see 'General' on page 11-2

1. Press  (or **F1** on the optional hardware keyboard) to open the electronic Instructions for Use.
2. Use the trackball to select the desired chapter.
3. To look for something specific, use the **Find** tab and type in the keyword to find.
4. To adapt the screen display (if necessary) use either **Hide** or **Options**. **Print** enables to print sections of the Instructions for Use or the whole Instructions for Use.
5. Press **Exit** either on the touchpanel or the hardkey button to leave the Instructions for Use.

4.3 Basic operations

Gain

Gain increases or decreases the amount of echo information displayed in an image. Gain adjustment is available in all modes.

1. Press the respective mode button to select a mode.
2. Rotate the same mode button to adjust the gain.

Zoom

Two different zoom functions are available: High-definition Zoom (HD Zoom) and Pan Zoom. Pan Zoom is available at any time by simply rotating the **Zoom** button. To use HD or Pan Zoom follow the steps below:

1. Press **Zoom** on the user interface to start the zoom function.
2. A reference image appears on the monitor screen.
3. Modify the size of the zoom window by rotating the **Zoom** button or by using the trackball keys.
4. Modify the position of the zoom window by using the trackball and the trackball keys.
5. Press **Zoom** again to activate the last used **Zoom** or use the corresponding trackball keys (left/right) for Pan Zoom or HD Zoom.
6. Press **Zoom** again to exit the zoom function.

Depth

Depth adjusts the field of view. It increases the field of view to look at larger or deeper structures; it decreases the field of view to look at structures near the skin line. Depth can only be adjusted in scan mode.

1. Flip the **Depth** switch down to increase the depth range.
2. Flip the **Depth** switch up to decrease the depth range.

Info *Changing the depth may change the acoustic output indices. Observe the output display for possible effects.*

Focus

Focus adjusts the number of focal zones.

1. The number of focal zones is displayed at the right side of the touch panel.
2. Tap on the symbol to add additional focal zones (cycles from 1-4).
3. Flip the control for focal zones to change the depth position of the focal zone(s).

Automatic optimization

The **auto** function optimizes the contrast resolution in the resulting image.

1. Press **auto** to activate the function.
2. Press **auto** again to update the optimization.
3. Double-click **auto** to end the optimization.

Cine

Cine images are constantly being stored by the system and are available for playback or manual review via cine. Cine can be viewed as a continuous loop via Cine Loop or manually frame by frame via the trackball.

1. Press **Freeze** to activate Cine.
2. Press **Img.** or **Cine** (lower trackball button) to switch between Image mode and Cine mode.
3. The Cine display (located at the lower right corner of the monitor) indicates which frame you are viewing of the whole loop, as well as the total acquired time of the loop. On the left side of the cine bar the programmed cine storage time for the P-key is shown.

Cine gaps: If a data-interruption occurred during scanning, this  icon appears in the left upper corner when the cine cursor is 0.5sec before or after the marked cine gap (missing frames). However, in case that also a time-trace (e.g. PW-trace) is displayed, the cine gap (missing frames) is additionally indicated in the time-trace.

This page was intentionally left blank.

Chapter 5

Probes and Biopsies

<i>Probe safety</i>	5-2
<i>Cleaning and maintenance of probes</i>	5-5
<i>Probes</i>	5-22
<i>Biopsies</i>	5-25
<i>Overview of all probes and biopsies</i>	5-32

5.1 Probe safety

General probe safety



Warning

Do not use damaged or defective probes. Injury to the operator or patient may occur if cracks, cuts, sharp edges or exposed wiring exist. Cleaning and/ or gel solutions may leak into the probe resulting in electrical shock. Discontinue use, immediately disconnect the ultrasound probe and notify the GE Service representative.

Failure to follow these precautions can result in serious injury.



Warning

If a probe has dropped on the floor or on any other hard surface, immediately disconnect the probe from the ultrasound system. Do not use the probe any more. There is a risk of electric shock due to damaged electrical insulation.



Caution

In case HF surgical equipment is used in combination with a probe placed on the patient, the following protective measures have to be taken to avoid the risk of burns to the patient:

- Keep a large distance between the HF surgical field and the applied probe
- Ensure that the neutral electrode of the HF surgical equipment is correctly positioned



Caution

Only use approved coupling gels and cleaning / disinfection agents, see Probe Care Card.



Caution

If the gel comes in contact with the eye, consult the gel manufacturer's instructions.



Caution

Do not immerse the probe into any liquid beyond the immersion level. Never immerse the probe connector into any liquid.



Caution

Before and after each use, inspect the probe's lens, cable, and casing. Look for any damage that would allow liquid to enter the probe. If any damage is found, the probe must not be placed into any liquid (e.g. for disinfection) and must not be used until it has been inspected and repaired/ replaced by a GE ULTRASOUND KOREA, LTD. Service Representative.

Note



Keep a log of all probe maintenance, along with a picture of any probe malfunction.



Caution

Adequate cleaning and disinfection is necessary to prevent disease transmission.

- The user is responsible to ensure adequate cleaning and disinfection of ultrasound probes. Probes are not disinfected and not sterile when delivered.
- High-level disinfection is recommended for surface probes and is required for endocavity probes.
- In addition to cleaning and disinfection the use of sterile, legally marketed probe sheaths for intracavitary procedures is recommended.
- In case of using pre-lubricated sheaths it must be confirmed that the lubricant-type is compatible with the ultrasound probe. In some cases, other lubricant-types may damage the probe. Please refer to Probe Care Card.
- Probes must be cleaned and disinfected before they are replaced or disposed.

	<p>Caution</p> <p>Creutzfeldt-Jakob disease</p> <p>This device is not indicated for neurological use. Neurological contact on patients with this disease must be avoided. If a device/probe becomes contaminated, there is no adequate means to disinfect it. In this case, the contaminated device/probe must be discarded in accordance with local biologic waste hazard procedures.</p>
	<p>Caution</p> <p>Do not apply excessive force when inserting or manipulating endocavity probes.</p> <p>Regularly inspect probes and biopsy equipment for rough surfaces, sharp edges or protrusions that could injure sensitive tissue.</p>
Note	<p><i>If 3D/4D probes are operated in continuous 4D mode for an unusually extended period of time, the surface temperature of the handle might get warm and exceed the limit according to IEC60601-1. The temperature of the applied part will stay within the limits according to IEC60601-2-37.</i></p>
	<p>Warning</p> <p>If 3D/4D probes are operated in continuous 4D mode for an unusually long period of time, 30 minutes, the surface temperature of the handle might get warm and exceed limits according to IEC60601-1. Continuous use of 4D mode should not exceed 30mins.</p>

Electrostatic Discharge Precautions

Electrostatic discharge (ESD), is commonly referred to as electric static shock, which is a naturally occurring phenomenon that results in the flow of an electrical charge between differently charged objects or persons. ESD occurs more frequently during conditions of low humidity, that can be caused by e.g. heating or air-conditioning. At low humidity conditions, electrical charges naturally build up on individuals and objects and can lead to static discharges. The following cautions help to reduce ESD effect:

	<p>Caution</p> <ul style="list-style-type: none"> • Do not touch connector pins on the probe connector or the console. • Handle the probe by the metal connector shell. • Make contact with a metal surface of the console before connecting a probe to the console. • The following precautions help reduce ESD: <ul style="list-style-type: none"> ○ anti-static spray on carpets, linoleum and mats ○ a ground wire connection between the console and the patient table or bed • Observe ESD precautions when handling or connecting probes.
---	---

Typically an ESD/EMC event results in an intermittent ultrasound image degradation for the time the ESD/EMC event is present. In rare cases the ultrasound system might show an error-message that can be confirmed by the operator. In other cases the ultrasound system might stop to operate and require a re-boot to re-establish the functionality.

General information

Observe the following information:

- Sporadically, silicone grease can leak in small amounts from the probes' cable bushing. This leakage is not a failure or harmful to the human body. Silicone grease does not contain any hazardous substances and is only used to seal the cable bushing. In case of a leakage wipe the grease with a cloth.
- Thermal safety: Maintaining a safe thermal environment for the patient has been a design priority at GE ULTRASOUND KOREA, LTD.. The operating temperature of the applied part of the probe stays below 43 °C if used as intended.

- Probes may generate slight noise emissions when operated in volume mode.
- The high elasticity of the probe surface ensures an optimal coupling of the probe. This elasticity can lead to small deformations of the applied part. The intended use of the probe will be in no way affected by this deformation, and leads to no loss of the ultrasound image quality.
- Approved coupling gels support optimal transmission of energy between the patient and the probe.

When scanning in air (Ultrasound probe is not in contact with a human body or a phantom) most of the ultrasound energy is reflected at the lens-air surface and bounces back and forward between that interface and the transducer ceramics. Already the smallest deviation from the ideal geometrical shape of the reflecting interfaces can cause irregularities in the reverberation pattern across the transducer surface. However, when the probe is coupled to the human skin or a phantom by using a sufficient amount of coupling gel most of the ultrasound energy passes the lens-skin interface and these small geometrical deviations will have a negligible effect on the ultrasound signal and image quality. Therefore variations of the reverberation pattern along the transducer cannot be used for judging image and transducer quality. The use of a tissue mimicking phantom is strongly recommended to assess image quality.

Note *Mechanical 3D/4D ultrasound probes utilize Voluson oil in an enclosed capsule to provide the transmission of ultrasound waves from the transducer-elements to the acoustic window of the ultrasound probe. Due to technical limitations the formation of gaseous bubbles within the Voluson oil cannot be fully circumvented. Such gaseous bubbles may be visible in the ultrasound image when the ultrasound probe is oriented upwards and scanning in air. Any diagnostic influence caused by these gaseous bubbles is typically neglectable, especially when the orientation of the ultrasound probe is horizontal or facing downward. Thereby, the gaseous bubbles rise into the direction towards the cable-end of the ultrasound probe and are no longer visible in the ultrasound image. The presence of minor gaseous bubbles is normal and not categorized as a failure.*

Probes have been ergonomically designed to:

- Handle and manipulate with ease.
- Connect to the system with one hand.
- Be lightweight and balanced.
- Have rounded edges and smooth surfaces.

Probe Check

The **Probe Check** performs an automated analysis of the transducer element sensitivity. This test covers many, but not all possible probe defects. It is the operators responsibility to confirm normal function of the ultrasound probe before use.

The **Probe Check** can be launched for an active probe in 2D mode. **Probe Check** can be launched from the left touch panel menu by pressing the soft-key. When the test is started a message informing that the probe to be tested has to be clean appears. Press **Start Test** to launch the test or **Cancel**.

5.2 Cleaning and maintenance of probes

The information provided in this chapter is intended to increase user awareness of the risks of disease transmission associated with using this equipment and provide guidance in making decisions directly affecting the safety of the patient as well as the equipment user.

Diagnostic ultrasound systems utilize ultrasound energy that must be coupled to the patient by direct physical contact. Depending on the type of examination, this contact occurs with a variety of tissues.

The level of risk of infection varies greatly with the type of contact.

One of the most effective ways to prevent transmission between patients is with single use or disposable devices. However, ultrasound transducers are complex and expensive devices that must be reused between patients. It is very important, therefore, to minimize the risk of disease transmission by using barriers.

Note *Read all safety precautions before proceeding.*

Probe immersion levels*

All probes labeled "IPX7" are watertight up to a minimum of 5 cm above the probes strain relief. If the probe is not explicitly marked as IPX7, only the scan head is watertight and the rest of the probe is IPX0 according to IEC 60601-2-37.

Note *Read all safety precautions before proceeding.*

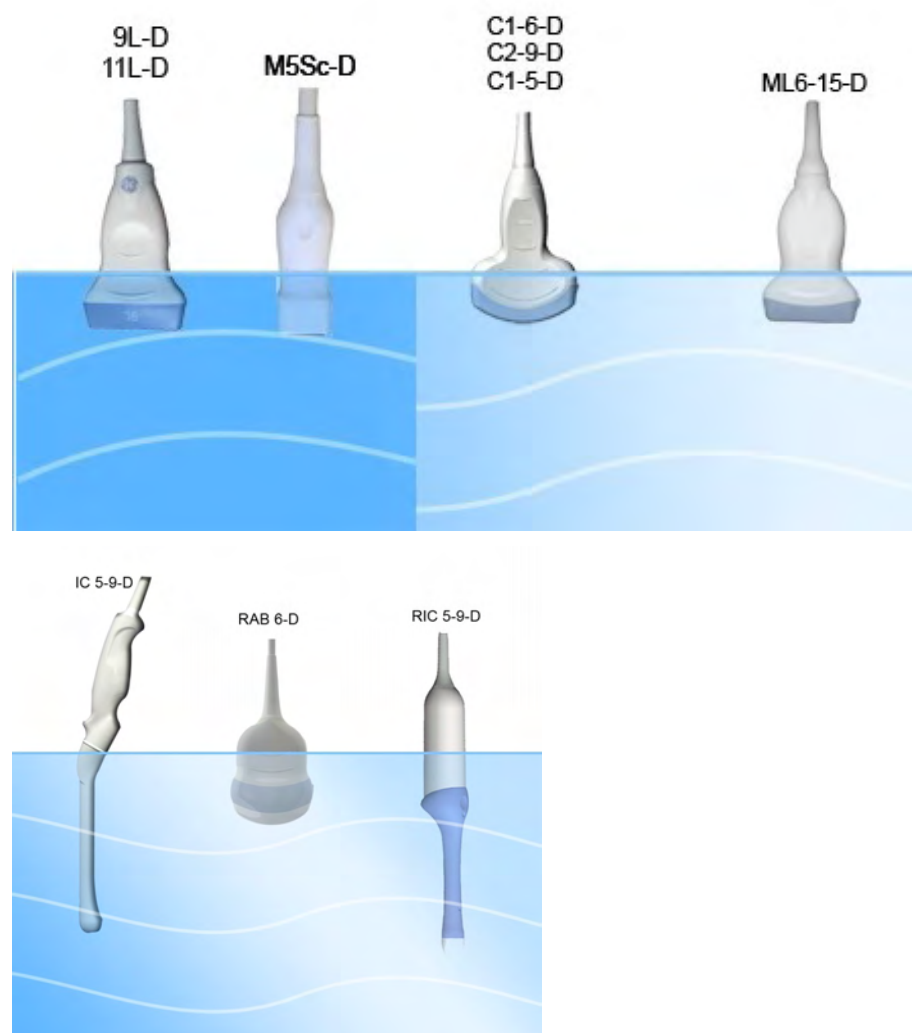

Probe maintenance intervals

The following maintenance schedule is suggested for probes and biopsy equipment to ensure proper operation and safety.

Action	Daily	After / Before Each Use	As Necessary
Inspect the Probes	-	X	X
Clean the Probes	X	X	X
Disinfect endocavity probes	-	X	X
Disinfect all other probe types	-	X	X

Environmental requirements for probes

Probes can be used in clinical environment.

Ensure that the probe face temperature does not exceed the normal operation temperature range.

Probes must be operated, stored, or transported within the parameters outlined below.

	Operational	Storage	Transport
Temperature	+18° to +30° C (+64°F to +86°F)	-10° to +50° C (+14°F to +122°F)	-10° to +50° C (+14°F to +122°F)
Humidity	30% to 75% RH non-condensing	10% to 85% RH non-condensing	10% to 85% RH non-condensing
Pressure	700hPa (3000m) to 1060hPa	700hPa (3000m) to 1060hPa	700hPa (3000m) to 1060hPa

5.2.1 Cleaning and Disinfection of Probes

Note *This chapter is equivalent to Addendum 5661328*

Probe Care Cards

The Probe Care Card contains a list of chemicals that have been tested for compatibility with GE Ultrasound probes. The reprocessing instructions provided in this document have been validated with the chemicals specified in 'Chemicals Used for Efficacy Validation' on page 5-16. The Probe Care Card is supplied with every probe and can also be downloaded from:

Support Documentation Library Web Site:
https://www.gehealthcare.com/support/manuals
Ultrasound Probe Web Site
http://www.gehealthcare.com/transducers

Table 5-1 Documentation and Probe Web Links

To prevent transmission of disease, adequate cleaning and disinfection are necessary before first use, between patient use, and every time the probe is stored or transported in a non-clean container like shipping case.

All probes must be thoroughly cleaned prior to disinfection.

The required level of disinfection is based on (see table below):

Type of tissue	Care Method
Intact skin	Cleaning followed by Intermediate-Level Disinfection (wipe or spray)
Non-intact skin or mucosal	Cleaning followed by High-Level Disinfection (soaking or use of a trophon® EPR or trophon2)

Table 5-2 Care methods

Note According to FDA Guidance and CDC Guideline, ILD have HBV, HIV, and tuberculocidal claims. HLD refer to FDA-cleared high-level disinfectants.

Note There are no adequate means to disinfect a probe that has been contaminated by prions, such as Creutzfeldt Jacob’s disease. In this case, the contaminated probe **MUST BE** discarded in accordance with local biologic waste hazard procedures.

Probe Pre-Treatment at the Point of Use (Required for All Probes)

Thorough cleaning is a mandatory first step to allow adequate subsequent disinfection or sterilization. Choose the most convenient method, either the wipe or enzymatic soak.



Warning

DO NOT clean the probe in an automated washer-disinfector, due to the possible damage of the connector/console interface.

Use necessary precautions (e.g. gloves, face screen and gown), as directed by your facility.

The pre-treatment step is for removal of the protective sheath, if used, the gel and gross contamination.

1. After each use, remove protective sheath from the probe and remove the coupling gel by wiping from the cable strain relief to the acoustic lens end (i.e. from cleanest to dirtiest area) with a soft, low-/ non-linting cloth or cleaning wipe.



Caution

USE non-abrasive cloth or wipe, such as Kimwipes™ Delicate Task Wipers or equivalent.

DO NOT use a twisting motion when wiping the probe. To extend the life of the probe acoustic lens, pat dry only.

2. Wipe the cable with one of the wipes listed in the probe compatibility website from the strain relief to the connector. Wipe the cable with a low-lint cloth dampened with potable water to remove chemical residue. Dispose of the cloth, wipe and gloves in the clinical trash.

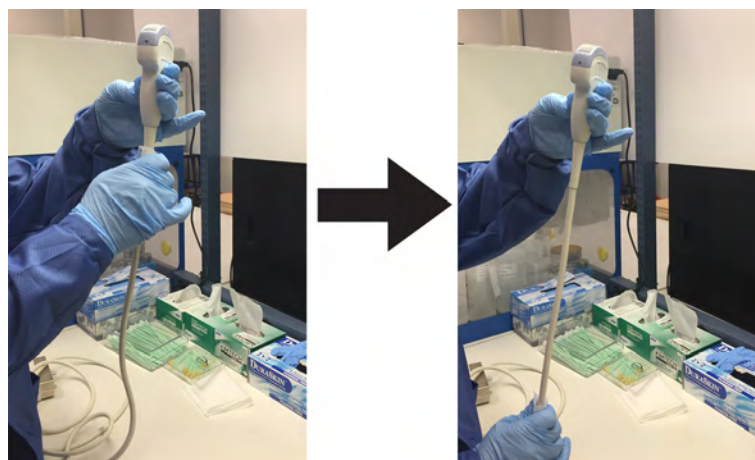

Figure 5-1 Cleaning the Probe Cable

Note Use of wipes listed in the Probe Care Card may result in discoloration of the cable.

Warning



Use caution when cleaning the connector. This cable connector should only be cleaned with a slightly dampened cloth or wipe. Exposure to excessive moisture will result in damage to the probe and possibly the ultrasound console. DO NOT wet the connector/console interface surface or labels.

3. After each use, inspect the lens, cable, and housing of the probe. Look for any damage that would allow liquid to enter the probe.



Danger

If the probe is damaged, do not place it into any liquid (e.g. for disinfection) and do not use it until it has been inspected and repaired/replaced by a GE Service Representative.

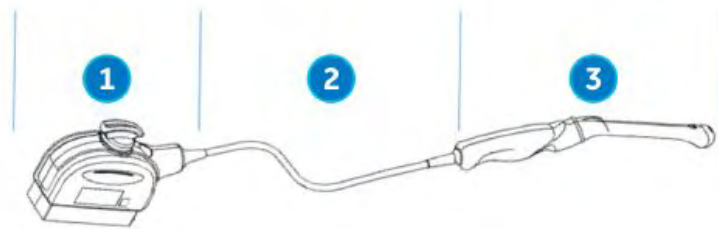

Figure 5-2 Inspect the Lens, Cable, and Probe House After Each Use

1 Connector	Cleaning only
2 Cable	Processed using cleaning/disinfectant wipes
3 Probe	Cleaning followed by appropriate level of disinfection

Table 5-3 Cleaning or Disinfection Portions

The processing instructions provided in this document have been validated per ISO 17664:2021 to properly prepare GE Ultrasound probes for re-use, with the chemicals mentioned in 'Reusable Probe Biopsy Guide Processing Procedures' on page 5-19. It remains the responsibility of the processor to ensure that the processing is performed as specified in this document. This may require verification and routine monitoring of the process.

Manual cleaning is required to ensure the probes are cleaned to the extent necessary for further processing. Choose the most appropriate method, either the wipe or enzymatic soak.

Probe Manual Cleaning Instructions - Cleaning with Wipes

1. Hold the probe at the proximal end near the strain relief cable. DO NOT suspend or hold the probe by the cable as this may damage the probe.
2. Dispense a cleaning wipe from the wipe canister.
3. Gently wipe the probe with a cleaning wipe from the cable strain relief to the acoustic lens, to maintain a cleanest to dirtiest approach. Gently wipe the probe's acoustic lens.

Note *Pay special attention to acoustic lens, edges, and crevices, removing all gel, product, and patient contribution.*

4. Turn the probe and continue wiping until the entire surface of the probe has been wiped. As the wipe becomes visibly soiled, discard the wipe into clinical trash and dispense fresh wipes as needed.

As needed for additional focused cleaning to crevices, wrap a clean wipe around a soft nylon bristle brush or other suitable instrument to access crevices, such as biopsy notches.

5. Visually inspect the probe for any remaining soil and, if necessary, repeat steps 3 and 4 until the probe is visibly clean.

Note Clean the probe holder of the ultrasound system before returning the probe back to the system (refer to the probe holder cleaning instruction in ultrasound system Instructions for Use for details).

6. Thoroughly dry the probe using a clean, low-/non-linting, soft cloth or wipe. Pat dry acoustic lens.

Probe Manual Cleaning Instructions – Enzymatic Detergent

1. Ensure the probe has been disconnected from the console. Put on a clean pair of gloves and fill a sink or basin with warm potable water (30 - 40°C) to a level allowing immersion of the probe up to the immersion line shown in the Instructions for Use.
2. Prepare the cleaning solution in accordance with the detergent manufacturer’s instructions.
3. Immerse the probe in the prepared cleaning solution up to the immersion line and ensure no air bubbles are trapped on the surface.



Caution
DO NOT submerge probe beyond the immersion line shown in the Instructions for Use.

Note For IC5-9-D probes with serial numbers 780333WX1 or greater (example 780334WX1, 780335WX1), refer to the figure below for the soaking level. The prefix number, i.e. 780333 for 780333WX1, indicates serial number sequence.



Figure 5-3 Probe Immersion Level for IC5-9-D

1	Serial number location
---	------------------------

Note Over-exposing ultrasound probes to cleaning solution may damage the ultrasound probe.

4. While immersed in the cleaning solution, brush with a clean, soft, nylon bristle brush from the base of the cable strain relief to the distal tip is critical to ensure cleaning and disinfection efficacy.

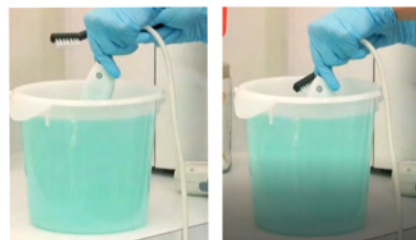

Figure 5-4 Cleaning the probe using a brush



Caution
Do not use the brush on the probe acoustic lens.

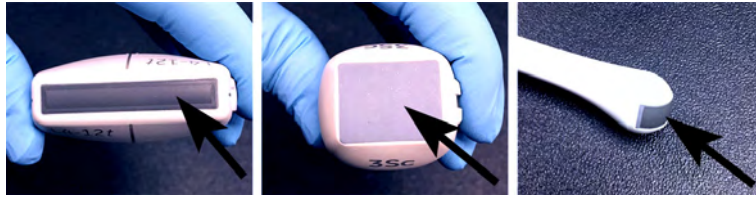

Figure 5-5 Probe Lens Examples

5. Continue brushing the probe for not less than the minimum contact time listed on the detergent manufacturer's label.
6. Visually inspect the probe for soil. Repeat Steps 3 through 5 until all visible soil has been removed from the surface of the probe.
7. Rinse the probe under running warm potable water (30 - 40°C) for not less than 2 minutes. Scrub the surface of the probe with a clean, soft, nylon bristle brush from the base of the cable strain relief to the acoustic lens.



Caution

Do not use the brush on the probe acoustic lens.

Note

Discard solutions and rinse waters in accordance with local regulations

8. Visually inspect the device in a well-lit area to ensure all surfaces are free from residual cleaning solution. Repeat Step 7 if visible cleaning solution is observed.
9. Thoroughly dry the probe using a clean, low-/non-linting, soft cloth or wipe. Pat dry acoustic lens.



Caution

USE non-abrasive cloth or wipe, such as Kimwipes™ Delicate Task Wipers or equivalent. DONOT use a twisting motion when wiping the probe. To extend the life of the probe acoustic lens, pat dry only.

Note

Clean the probe holder of the ultrasound system before returning the probe back to the system (refer to the probe holder cleaning instruction in ultrasound system user manual for details).

Cable and Connector Cleaning/Disinfection

The connector can be cleaned with a wipe dampened with alcohol. Use caution when cleaning the connector, wring wipe to remove excess of liquid before wiping the connector. Prevent introduction of foreign objects in the system connector assembly. Do not apply excessive force on any component of the system connector.



Warning

Exposure to excessive moisture will result in damage to the probe and possibly the ultrasound console. DO NOT wet the connector/console interface surface or labels (Refer to red circles in picture below). DO NOT clean the probe in an automated washer-disinfector.

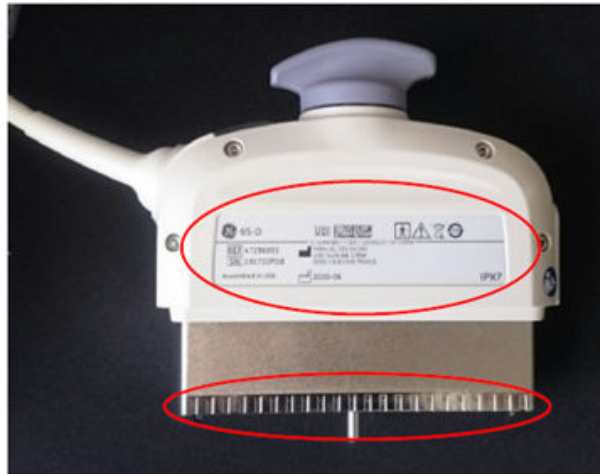

The cable should be processed using cleaning/disinfectant wipes. If the cable has been in contact with risk factors, such as blood and/or mucous, cleaning should be followed by disinfection.

1. Dispense a cleaning/disinfectant wipe from the wipe canister.
2. Wipe the cable with a cleaning/disinfectant wipe from the handle strain relief to the connector strain relief (as shown in the picture below). As the wipe becomes visibly soiled, discard the wipe into clinical trash and dispense fresh wipes as needed.

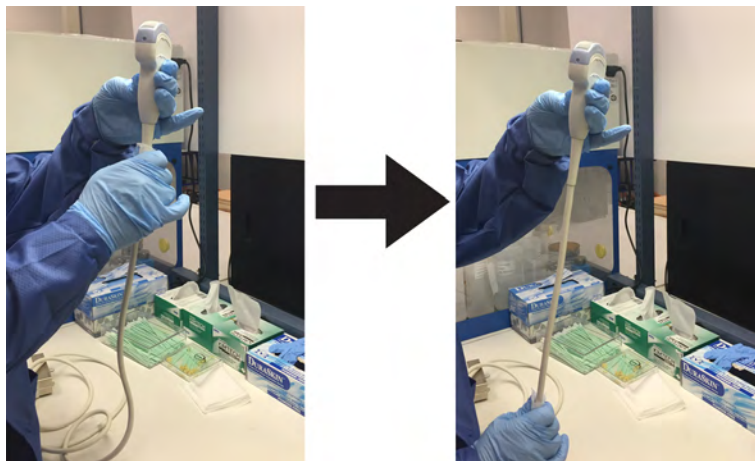

Figure 5-6 Cleaning the Probe Cable

Note Some detergents and disinfectants might cause discoloration to the probe's cable.

3. Visually inspect the cable for any remaining soil and, if necessary, repeat cleaning until the cable is visibly clean.

If disinfection is needed, dispense a new cleaning/disinfectant wipe and continue wiping the cable. Use as many wipes as needed, to ensure all surfaces remain wet for the minimum required contact time mentioned in the table "Chemicals used for Efficacy Validation". Discard the wipes into clinical trash.

4. Saturate a soft, low-/non-linting cloth with Critical Water (remove excess water, wipe should be damp but not dripping) and thoroughly wipe all surfaces of the cable to remove chemical residues. Discard the cloth into clinical trash.

Note *Critical Water is water that is treated (usually by a multistep treatment process that could include a carbon bed, softening, DI, and RO or distillation) to ensure that the microorganisms and the inorganic and organic material are removed from the water to an appropriate level (Refer to AAMI TIR34/ST108).*

Use of this type of water will reduce the recontamination of probes during processing.

5. Let the cable air dry until visibly dry.

Probe Intermediate-Level Disinfection (ILD)

For Intermediate-Level Disinfection of intact skin contacting probes, choose either the spray or wipe method.

Note *Probes that contact only intact skin may be disinfected in this manner. All probes that contact non-intact skin, mucosal membranes (e.g., endocavitary) require High-Level Disinfection.*



Caution

After each use, inspect the lens, cable, and housing of the probe. Look for any damage that would allow liquid to enter the probe.



Danger

If the probe is damaged, DO NOT place it into any liquid (e.g. for disinfection) and DO NOT use it until it has been inspected and repaired/replaced by a GE Service Representative.

Probe Intermediate-Level Disinfection - Spray or Wipe

Note *Disinfectant exists either in pre-impregnated wipe or in spray. The spray should be sprayed onto a low-/non-linting cloth and then used in same way as a pre-impregnated wipe. In steps 1 to 4 of this section, “wipe” will then stand for a pre-impregnated wipe as well as for a low-/non-linting cloth saturated with disinfectant.*

Do not spray the probe directly

Use necessary precautions (e.g. gloves, face screen and gown), as directed by your facility.

1. Dispense a new wipe from the wipe canister.
2. Holding the probe near the strain relief, wipe the acoustic lens and handle areas.
 - Slightly rotate the probe after each wiping pass and continue wiping until all areas of the probe and handle have been wetted.
 - Wring the wipe above recessed areas and ridges for dripping liquid directly onto the less accessible surfaces.
3. Using fresh wipes, repeat step 2 as many times as needed to ensure all surfaces remain wet for the minimum required contact time listed in table 1-3.

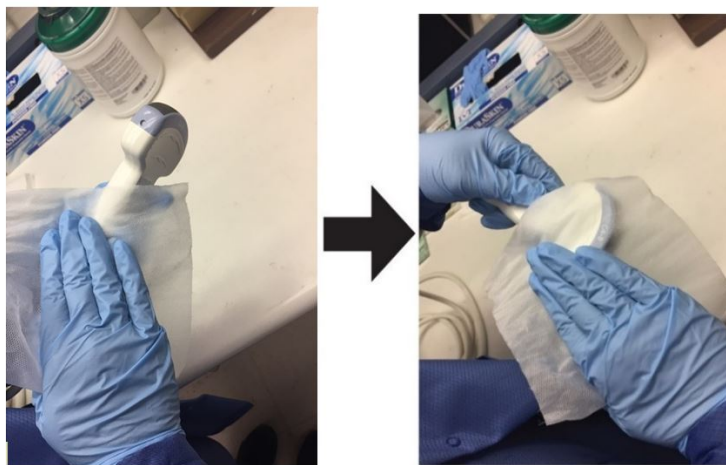

Figure 5-7 Disinfecting the Probe With Slight Rotation

- Saturate a soft, low-/non-linting wipe with Critical Water (remove excess water, wipe should be damp but not dripping) and thoroughly wipe all surfaces of the probe to remove chemical residue. Discard the wipe.

Note *Critical Water is water that is treated (usually by a multistep treatment process that could include a carbon bed, softening, DI, and RO or distillation) to ensure that the microorganisms and the inorganic and organic material are removed from the water to an appropriate level (Refer to AAMI TIR34/ST108). Use of this type of water will reduce the recontamination of probes during processing.*

- Thoroughly dry all surfaces of the probe using a soft, low-/non-linting wipe or cloth, changing wipes/cloths when necessary to ensure the probe is completely dry. Pat dry acoustic lens. Visually inspect the probe to ensure all surfaces are dry. Repeat drying steps if any moisture is visible.
- If the probe is not immediately reused, store the probe in a manner that will protect and keep the probe from being recontaminated. Refer to the Probe Transportation and Storage section for additional information.

Note *Ensure that probe holder of the ultrasound system has been disinfected before returning the probe back to the system (refer to the probe holder disinfection instruction in ultrasound system user manual for details).*

Probe High Level Disinfection (HLD)

High-Level Disinfection is required for devices that contact intact mucous membranes or non-intact skin. High Level Disinfection can be performed using either a disinfectant soaking method or an automated system such as trophon EPR and trophon2.



Warning

DO NOT disinfect the probe in an automated washer-disinfector, due to the possible damage of the connector/console interface.



Danger

If the probe is damaged, remove it from patient use. Clean and disinfect the probe before contacting your GE Service Representative for inspection and repair/replacement.



Caution

After each use, inspect the lens, cable, and housing of the probe. Look for any damage that would allow liquid to enter the probe.

Note *All semi-critical probes* that contact mucous membranes require High-Level Disinfection.*

** Semi-critical probes are probes that contact mucous membranes or non-intact skin.*

Note *Handles of semi-critical probes that are not submerged during High-Level Disinfection require low or Intermediate-Level Disinfection to avoid cross contamination.*

Probe High Level Disinfection - Soak

- Ensure the probe has been disconnected from the console.
Use necessary precautions (e.g. gloves, face screen and gown), as directed by your facility and fill a sink or basin with High-Level Disinfectant prepared in accordance with the disinfectant manufacturer's instructions to a level allowing immersion of the probe up to immersion line shown in the System user manual.
Example of probe immersion diagram is shown in chapter 'Cleaning and maintenance of probes' on page 5-5 .



Caution Ensure no liquid comes into contact with the probe connector pins or labels.

2. Immerse probe in the disinfectant up to the immersion line shown in the Ultrasound console's user manual and ensure no air bubbles are trapped on probe's surface. Ensure the probe remains in the disinfectant for at least the minimum contact time listed in the table "Chemicals used for Efficacy Validation".



Caution

The acoustic lens/cap should not be resting against the tank/basin surface. Carefully place the probe in the basin, taking care not to damage the transducer acoustic lens. The probe may be suspended using a special support.

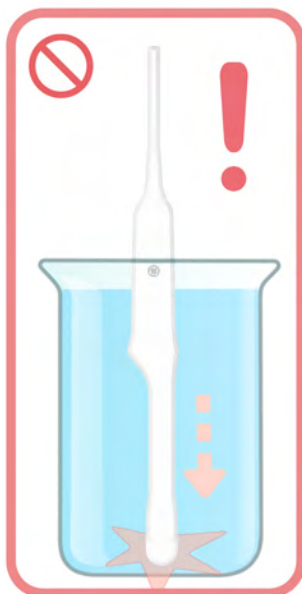

Figure 5-8 Probe suspended in disinfectant basin

For IC5-9-D probes with serial numbers 780333WX1 or greater (example 780334WX1, 780335WX1), refer to the figure below for the soaking level. The prefix number, i.e. 780333 for 780333WX1, indicates serial number sequence.



Figure 5-9 Probe Immersion Level for IC5-9-D

1	Serial number location
---	------------------------

Note *Over-exposing ultrasound probes to high-level disinfectants may damage the ultrasound probe. NEVER exceed the disinfectant manufacturer's maximum exposure time.*

3. Thoroughly rinse the probe by immersing it in a large volume of critical (purified) water for a minimum of 1 (one) minute. Remove the probe and discard the rinse water. Repeat Step 3 two additional times, for a total of 3 (three) rinses.

Do not reuse the water. Always use fresh volumes of water for each rinse.

Note *Critical Water is water that is treated (usually by a multistep treatment process that could include a carbon bed, softening, DI, and RO or distillation) to ensure that the microorganisms and the inorganic and organic material are removed from the water to an appropriate level (Refer to AAMI TIR34/ST108).*

Use of this type of water will reduce the recontamination of probes during processing.

**Warning**

Failure to properly rinse probes with water following disinfection may cause skin irritation.

Note *Discard solutions and rinse waters in accordance with local regulations*

4. Thoroughly dry all surfaces of the probe using a soft, low-/non-linting wipe or cloth, changing wipes/cloths when necessary to ensure the probe is completely dry.

**Caution**

USE non-abrasive cloth or wipe, such as Kimwipes™ Delicate Task Wipers or equivalent. DO NOT use a twisting motion when wiping the probe. To extend the life of the probe acoustic lens, pat dry only.

Visually inspect the probe to ensure all surfaces are dry, including crevices. Repeat drying steps if any moisture is visible.

5. If the probe is not immediately reused, store the probe in a manner that will protect and keep the probe from being recontaminated. This may be accomplished by placing the probe in a storage cabinet with filtered air flow and/or by using a disposable storage cover placed over the probe.

Note *Ensure that probe holder of the ultrasound system has been disinfected before returning the probe back to the system (refer to the probe holder disinfection instruction in ultrasound system user manual for details).*

Probe High-Level Disinfection (HLD) - Tristel Trio and Tristel Duo ULT

Note *These instructions can be used only for disinfection of RIC5-9-D.*

1. Use necessary precautions (e.g. gloves, face screen and gown), as directed by your facility.
2. Activate a new disinfection wipe as per manufacturer's instructions (Tristel Sporicidal Wipe & Tristel Activator Foam or Tristel Dry Wipe & Tristel Duo ULT).
3. Holding the probe near the strain relief, wipe the acoustic lens and handle areas.
4. Slightly rotate the probe after each wiping pass and continue wiping until all areas of the probe and handle have been wetted.
5. Wring the wipe above recessed areas and ridges for dripping liquid directly onto the less accessible surfaces.
6. Ensure all surfaces remain wet for minimum 1 (one) minute.
7. To remove chemical residue, use the Tristel Rinse Wipe or saturate a soft, low-/non-linting wipe with Critical Water (remove excess water, wipe should be damp but not dripping) and thoroughly wipe all surfaces of the probe. Discard the wipe.

Note *Critical Water is water that is treated (usually by a multistep treatment process that could include a carbon bed, softening, DI, and RO or distillation) to ensure that the microorganisms and the inorganic and organic material are removed from the water to an appropriate level (Refer to AAMI TIR34/ST108).*

Use of this type of water will reduce the recontamination of probes during processing.

8. Thoroughly dry all surfaces of the probe using a soft, low-/non-linting wipe or cloth, changing wipes/cloths when necessary to ensure the probe is completely dry. Pat dry acoustic lens.

Visually inspect the probe to ensure all surfaces are dry. Repeat drying steps if any moisture is visible.

9. If the probe is not immediately reused, store the probe in a manner that will protect and keep the probe from being recontaminated.

Note *Ensure that probe holder of the ultrasound system has been disinfected before returning the probe back to the system.*

Probe High-Level Disinfection (HLD) - trophon EPR and trophon®2

When performing High-Level Disinfection of GE ultrasound probes with the trophon EPR and trophon2, it is not necessary to disconnect the probe from the ultrasound system. The probe must be inactive (not selected) during the disinfection cycle.

1. Upon completion of probe cleaning, ensure the probe has been thoroughly dried with a clean, low-lint soft cloth or wipe. Carefully dry the probe by wiping from the distal tip to the strain relief. Pat dry lens.



Caution

DO NOT use abrasive paper products when cleaning or wiping a GE Ultrasound Probe. The use of abrasive wipes can damage the soft lens (acoustic window). To extend the life of the probe lens, pat dry only.

2. Visually inspect the probe to ensure the probe is visibly clean.
 3. Follow the trophon instructions for probe placement and operation of the trophon system. Incorrect positioning of the probe may lead to High-Level Disinfection not being achieved.
-



Caution

Damage to the probe may occur if the probe is placed in contact with the trophon chamber wall. Curved probes must be correctly positioned in the chamber using the Curved Probe Positioner (CPP) supplied with the trophon system.

4. Once the trophon High-Level Disinfection cycle is complete, don a new set of gloves and promptly remove the probe from the trophon machine. DO NOT allow the probe to remain in the machine for extended periods of time.
 5. Hold the probe at the proximal end near the strain relief cable. DO NOT suspend or hold the probe by the cable, as this may damage the probe.
 6. Wipe the probe from the distal end to the proximal end with a clean, low-lint, soft cloth or wipe to remove any residual hydrogen peroxide from the probe surface.
-



Caution

DO NOT use a twisting motion or abrasive paper products when wiping the probe. To extend the life of the probe lens, pat dry only.

7. If the probe is not immediately reused, store the probe in a manner that will protect and keep the probe from being recontaminated. This may be accomplished by placing the probe in a storage cabinet with filtered air flow and/or by using a disposable storage cover placed over the probe

Chemicals Used for Efficacy Validation

The table below lists the products and intended use (clean, Intermediate-Level Disinfection, High-Level Disinfection) that were validated.

Product Type	Trade Name	Manufacturer	Minimum Contact Time	Active Ingredient
Cleaning (Wipe)	Oxivir® Tb	Diversey	N/A	Hydrogen Peroxide
Cleaning (Soak)	Enzol® (Cidezyme®)	Advanced Sterilization Products® (J&J)	1-Minute Soak	Proteolytic Enzymes
	MetriZyme™	Metrex™		
	Prolystica® 2X Concentrate Presoak & Cleaner	Steris		
Intermediate-level Disinfectant (wipe or liquid)	Oxivir® Tb	Diversey	10-Minute Exposure	Hydrogen Peroxide
Intermediate-level Disinfectant (wipe)*	Sani-Cloth AF3	PDI	3-Minute Exposure	Quaternary ammonium
High-level Disinfectant (Soak)	Cidex® OPA (FDA-Cleared)	Advanced Sterilization Products® (J&J)	12-Minute Soak	Ortho-phthalaldehyde
	McKesson OPA/28	McKesson	10-Minute Soak	
High-level Disinfectant (wipe)**	Cidex® OPA (FDA-Cleared)	Tristel Trio	1-Minute Exposure	Chlorine dioxide
	McKesson OPA/28	Tristel Duo ULT		

Table 5-4 Chemicals used for Efficacy Validation

** Tristel Trio and Tristel Duo ULT are validated only for RIC5-9-D probe.

A full list of chemicals tested for compatibility is available at the GE Probe Web Site.

Covering the Probe using a Protective Sheath



Caution

Probe sheaths are disposable and must not be reused.



Caution

Protective barriers may be required to minimize disease transmission. Probe sheaths are available for use with all clinical situations where infection is a concern. Use of legally marketed, sterile probe sheaths is recommended* for intra-cavitary, intra-operative and biopsy procedures.

Note

Endoscopic, rectal, and transvaginal probes should be used with a single-use sterile sheath. (Marketing Clearance of Diagnostic Ultrasound Systems and Transducers, FDA June 27, 2019). Although a non-sterile transducer cover for all semi-critical procedures (e.g., endocavitary) is the minimal recommendation, a sterile cover is preferred. (Guidelines for Infection Prevention and Control in Sonography: Reprocessing the Ultrasound Transducer, SDMS, 2019).*

1. Place an appropriate amount of gel (sterile preferred) inside the protective sheath and/or on the transducer face.

Note

Failure to use imaging gel may result in poor image quality.

2. Insert probe into sheath, making sure to use proper sterile technique. Pull cover tightly over transducer face to remove wrinkles and air bubbles, taking care to avoid puncturing the sheath.

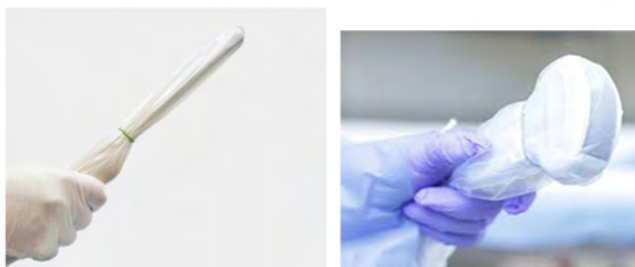

Figure 5-10 Applying the Sheath

Note *No gel was applied to the probe in this photo.*

3. Secure the sheath in place.
4. Inspect the sheath to ensure there are no holes or tears. If the sheath becomes compromised, stop the procedure and replace immediately.
5. After usage, discard the sheath into clinical trash.

5.2.2 Probe Transportation Storage Inspection and Disposal

Probe Transportation

Transport and store the ultrasound probes covered as needed and secured.

When transporting a clean or dirty ultrasound probe, ensure the probe is protected from cross contamination and possible damage. This can include the use of covers per the appropriate disinfection/contamination level, and the use of rigid containers or the probe holder on the ultrasound unit to secure.

Note *Do not use cloth or plastic bags to transport probes. This could result in damage to the probes.*

When using a rigid transport case, such as the shipping container or a transport case, ensure that the probe is clean, and avoid damage to the probe by allowing nothing to protrude beyond the case when closing the lid, and secure the system connector in place so as not to damage the transducer head or lens.



Warning

Placing an uncovered dirty or contaminated probe in a carrying case or shipping carton will contaminate the foam insert.



Caution

After each use, inspect the lens, cable, and housing of the probe. Look for any damage that would allow liquid to enter the probe.

Probe Storage

Prior to storage, it is essential to ensure the probe is completely clean and dry following disinfection.

If the probe is not immediately reused, store the probe in a manner that will protect and keep the probe from being re-contaminated. This may be accomplished by placing the probe lens upward on a wall mounted rack, probe holder on the ultrasound system, or in a storage cabinet with filtered air flow, using a disposable storage cover placed over the probe when needed. Avoid dangling the probe to prevent contact damage. For endocavity probes, the optional horizontal probe holder mounted on the ultrasound machine can be used.

Do not use the shipping case or any closed container for other than short term transportation or shipping.



Caution

Avoid lengthy exposure of the probe to direct sunlight or to a strong ultraviolet light source.

Probe inspection



Caution

When manipulating the probe, avoid dropping, impacting, or abrading the probe. This could damage acoustic lens, handle, cable or connector, or could break piezoelectric element.

Avoid excessive twisting, pulling, pinching or kinking of probe's cable assemblies.

Probes with cracks, abrasions or tears may harbor dangerous contaminants or may tear protective sheaths used with the ultrasound probe.

After each use, inspect the acoustic lens, cable, and housing of the probe. Look for any damages. Typical damages are listed below. For further questions, contact your GE HealthCare Service Representative.

- Probe body (shaft, handle, nose-piece): inspect for cracks, abrasions, or evidence of impact.
- Acoustic lens or cap: check for cuts, tears, gouging, abrasion, swelling, bubbling, or delamination.
- Strain relief and cable assembly: check for cracks, cuts, tears, abrasion, kinking, crushing, or inflexibility.
- System connector: check for foreign objects, broken latches, or bent pins and shielding.

GE HealthCare recommends regular electrical safety leakage testing to help ensure operator and equipment safety. Refer to the Console's Service Manual for details.



Danger

If the probe is damaged, remove it from patient use. Clean and disinfect the probe before contacting your GE HealthCare Service Representative for inspection and repair/replacement.



Caution

Make sure that the probe is stored dry. Storing the probe in any liquid will damage the probe.

For consumables and accessories, please contact your local GE HealthCare representative.

5.2.3 Reusable Probe Biopsy Guide Processing Procedures

This chapter contains information concerning reusable Ultrasound probe biopsy guides processing instructions.

Manual Cleaning

Note

Efficacy of this manual cleaning process has been shown using ENZOL Enzymatic Detergent.

1. Remove the biopsy guide and protective sheath(s) from the probe.
2. Whenever possible the biopsy guide should be rinsed immediately after use. If the biopsy guide cannot be cleaned immediately after use, cover the biopsy guide with a towel dampened with purified water. Devices may remain in this condition for a maximum of 4 hours.
3. Remove all visible soil. Flush the biopsy guide using utility water (30 - 40°C) for not less than 2 minutes.
4. Prepare the enzymatic detergent according to the manufacturer's recommendations, using utility water.
5. Submerge the biopsy guide in the prepared solution and soak for no less than 2 minutes.
6. After the 2-minute soak, while the biopsy guide is submerged in the cleaning solution, vigorously scrub the device with a soft nylon bristle brush.
7. Use a round nylon cleaning brush to clean the biopsy lumen. Use a syringe to flush cleaning solution through the lumen. Scrub the device for a minimum of 2 minutes.

8. Remove the device from the cleaning solution and rinse thoroughly under running utility water (30 - 40°C) taking care to remove any visible detergent. Rinse the device for a minimum of 1 minute.
9. Visually inspect the device for any residual soil or detergent. Repeat steps 6 through 8 until the device is visibly clean.

Note *Discard solutions and rinse waters in accordance with local regulations.*



Caution

Do not clean any portion of the attachment with methanol, ethanol, isopropanol, or any other alcohol base detergent. Such substances can cause irreparable damage to the attachment.

High-Level Disinfection

Note *High-Level disinfection efficacy of this manual process has been shown using Cidex OPA.*

1. Fill a sink or basin with high-level disinfectant prepared in accordance with the disinfectant manufacturer's instructions to a level allowing immersion of the biopsy guide.
2. Immerse the devices in the disinfectant solution and agitate to ensure all air bubbles are removed from the surface of the device.
3. Allow the devices to soak in the disinfectant solutions for least the minimum contact time listed in the disinfectant manufacturer's instructions for use.
4. Thoroughly rinse the device by immersing in a large volume of critical (purified) water for a minimum of 1 minute.

Note *Critical Water is water that is treated (usually by a multistep treatment process that could include a carbon bed, softening, DI, and RO or distillation) to ensure that the microorganisms and the inorganic and organic material are removed from the water to an appropriate level (Refer to AAMI TIR34/ST108).
Use of this type of water will reduce the recontamination of biopsy guide during processing.*

5. Repeat Step 4 two additional times, for a total of 3 (three) rinses using fresh volumes of water for each rinse.

Note *Discard solutions and rinse waters in accordance with local regulations.*

6. Thoroughly dry the biopsy guide using a low-/non-linting wipe. Visually inspect the biopsy guide to ensure all surfaces are clean and dry. Visually inspect the biopsy to ensure all surfaces are dry. Repeat drying steps if any moisture is visible..

Autoclave Sterilization

Note *Sterilization efficacy testing was performed using worst-case parameters for time, temperature and load density. Parameters listed in the tables are the minimum required to ensure a Sterility Assurance Level (SAL) of 10⁻⁶ or better.*

1. Place the cleaned, disinfected and disassembled biopsy guide in an approved autoclave pouch.
2. Sterilize using the following parameters:

Parameter	Cycle Type 1	Cycle Type 2
Sterilizer	Pre-vacuum	Pre-vacuum
Preconditioning Pulses	3	3
Temperature (Minimum)	132 degrees C	134 degrees C

Parameter	Cycle Type 1	Cycle Type 2
Exposure Time (Minimum)	4 Minutes	3 Minutes
Drying Time (Minimum)	15 Minutes	15 Minutes
Package Configuration	Tyvek Pouch (14 x 25 cm)	Tyvek Pouch (14 x 25 cm)

Table 5-5 Autoclave parameters

5.3 Probes

5.3.1 Intended use, contraindications and patient population

Intended use

Image Acquisition for diagnostic purposes including measurements on acquired image. Extracting tissue samples with guided and freehand biopsy.

Contraindications

Probes are not intended for:

- ophthalmic use or any use causing the acoustic beam to pass through the eye
Note that linear probes (e.g. 9L-D) are not intended for ophthalmic use or any use where the probe is directly applied to the eye, excluded scanning with dedicated ophthalmic artery settings across closed eye.

- intra-operative use that is defined as introducing probe into a surgical incision or burr hole

Abdominal and linear probes are not intended for:

- endocavity use

Patient population

- Age: all ages (incl. embryos and fetuses)
- Location: worldwide
- Sex: male, female and diverse
- Weight: all weight categories
- Height: no height limitations

5.3.2 Labeling

Each probe is labeled with the following information:

- Manufacturer
- GE HealthCare part number
- Probe serial number
- Probe designation provided on the top of the connector housing, so it is easily read when mounted on the system and is also automatically displayed on the screen when the probe is selected.

Note

Symbols used on the label: For more information see 'Description of symbols and labels' on page 2-3.

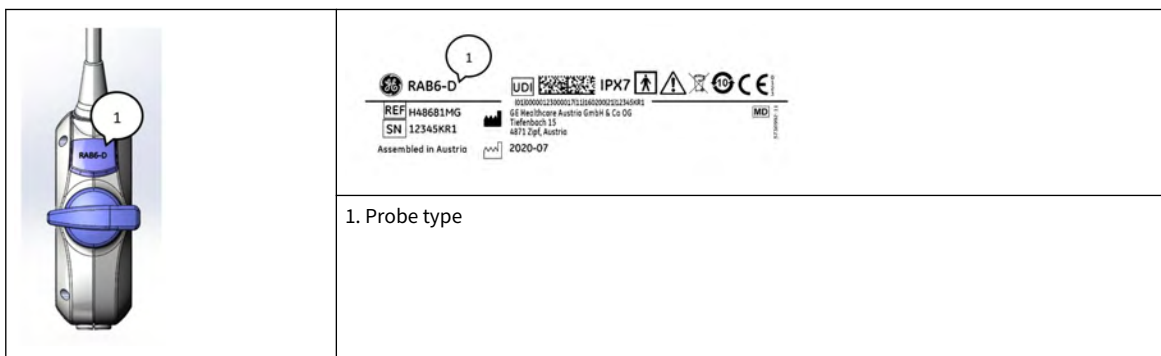

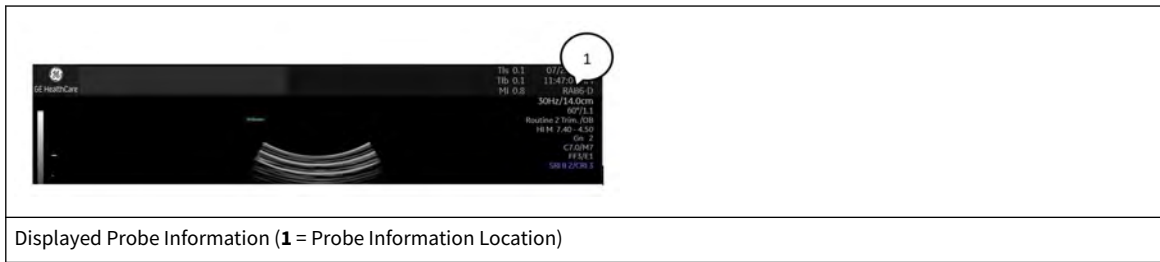

5.3.3 Clinical application specific settings



The Instructions for Use refer to probes that can be connected to the device. It might be possible that some probes, options or features are NOT available in some countries!

The below table shows which clinical application specific settings are provided for which probe.

2D Probe	Abdominal	Small-Parts	Obstetrics	Cardiology	Transrectal	Vascular	Gynaecology	Pediatrics	Cephalic	MSK	Breast
9L-D	-	X	X	-	-	X	-	X	-	X	-
11L-D	-	X	-	-	-	X	-	X	-	X	X
ML6-15-D	-	X	-	-	-	X	-	X	-	X	X
C1-5-D	X	-	X	-	-	-	X	-	-	-	-
C1-6-D	X	-	X	-	-	-	X	-	-	-	-
C2-9-D	X	-	X	-	-	-	X	X	-	-	-
IC5-9-D	-	-	X	-	X	-	X	-	-	-	-
M5Sc-D	-	-	-	X	-	-	-	X	X	-	-

3D/4D Probe	Abdominal	Small-Parts	Obstetrics	Cardiology	Transrectal	Vascular	Gynaecology	Pediatrics	Cephalic	MSK	Breast
RAB6-D	X	-	X	-	-	-	X	X	-	-	-
RIC5-9-D	-	-	X	-	X	-	X	-	-	-	-

5.3.4 Features

Symbol	Description
SW	Optional software feature
HW	Optional hardware feature
X	Available
-	Not available

Probes	Imaging Modes																															
	2D											M				PW			CW		Color			3D								
												AMM																				
	norm	HI	CRI	SRI*	B-Flow	Virtual Convex	Wide (max. angle)	BetaView	Shadow Reduction	Augment	M	MC	MHDFlow™	MTD	Update	Duplex	Triplex	HPRF	Update	Steerable	CFM	HD-Flow™	PD	TD	2D (norm)	CFM	PD	HD-Flow™	VCI	BF	Contrast	
9L-D	x	x	x	x	x	x	-	-	-	-	x	-	-	-	x	x	x	x	x	x	x	x	-	-	-	-	-	-	-	-	-	-
11L-D	x	x	x	x	x	x	-	-	x	x	x	-	-	-	x	x	x	x	-	-	x	x	x	-	-	-	-	-	-	-	-	-
ML6-15-D	x	x	x	x	x	x	-	-	x	x	x	-	-	-	x	x	x	x	-	-	x	x	x	-	-	-	-	-	-	-	-	-
C1-5-D	x	x	x	x	x	-	x	-	-	-	x	x	x	x	x	x	x	x	-	-	x	x	x	x	-	-	-	-	-	-	-	-
C1-6-D	x	x	x	x	x	-	x	-	x	x	x	x	x	x	x	x	x	x	x	x	x	x	x	-	-	-	-	-	-	-	-	-
C2-9-D	x	x	x	x	x	-	x	-	x	x	x	x	x	x	x	x	x	x	x	x	x	x	x	-	-	-	-	-	-	-	-	-
IC5-9-D	x	x	x	x	x	-	x	-	x	x	x	x	x	x	x	x	x	x	-	-	x	x	x	x	-	-	-	-	-	-	-	-
M5Sc-D	x	x	-	x	-	x	x	-	-	-	x	x	x	x	x	x	x	x	x	x	x	x	x	-	-	-	-	-	-	-	-	-
RAB6-D	x	x	x	x	x	-	x	x	x	x	x	x	x	x	x	x	x	x	-	-	x	x	x	x	x	x	x	x	x	x	x	x
RIC5-9-D	x	x	x	x	x	-	x	x	x	x	x	x	x	x	x	x	x	x	-	-	x	x	x	x	x	x	x	x	x	x	x	x

Probes	Advanced 4D ^{SW}								Advanced STIC ^{SW}								Elasto		ECG
	norm	Biopsy	CFM	PD	HD-Flow™	VCI	Contrast	norm	M	CFM	PD	HD-Flow™	TD	BF	XTD	Contrast	Elasto		
																	Elasto	Shear Elasto	
9L-D	-	-	-	-	-	-	-	-	-	-	-	-	-	-	x	x	-	-	x
11L-D	-	-	-	-	-	-	-	-	-	-	-	-	-	-	x	-	x	-	x
ML6-15-D	-	-	-	-	-	-	-	-	-	-	-	-	-	-	x	x	x	-	x
C1-5-D	-	-	-	-	-	-	-	-	-	-	-	-	-	-	x	x	-	-	x
C1-6-D	-	-	-	-	-	-	-	-	-	-	-	-	-	-	x	x	-	x	x
C2-9-D	-	-	-	-	-	-	-	-	-	-	-	-	-	-	x	-	-	-	x
IC5-9-D	-	-	-	-	-	-	-	-	-	-	-	-	-	-	x	-	x	-	x
M5Sc-D	-	-	-	-	-	-	-	-	-	-	-	-	-	-	-	x	-	-	x
RAB6-D	x	x	-	-	-	x	-	x	x	x	x	x	x	x	x	x	-	-	x
RIC5-9-D	x	x	-	-	-	x	x	x	x	x	x	x	x	x	x	x	-	-	x

5.4 Biopsies

5.4.1 Biopsy safety

General biopsy safety



Caution

A biopsy must only be performed by physicians with adequate experience. Under all circumstances the necessary safety precautions and sterility measures have to be respected.



Caution

All biopsy equipment depicted and described in these Instructions for Use has been validated for use with the system and software. If biopsy equipment which is not listed in these Instructions for Use is used, the user has the possibility to configure and store the predicted biopsy line. In this case the user has to be aware that the biopsy equipment/probe/system/software combination may not be validated and therefore responsibility for correct configuration and usage lies with the user.



Caution

- Every time before using a biopsy guide ensure its correct position and optimal fit on the probe.
- Always use a straight needle for each biopsy procedure.
- Before performing a biopsy ensure that the selected and displayed biopsy line corresponds to the biopsy needle guide mounted to the ultrasound probe (left/right).
- The biopsy needle and the biopsy needle guide (and the bore inside) must be sterile.



Caution

For detailed information on a biopsy guide, please contact the manufacturer of the biopsy guide.



Caution

Biopsy equipment is not sterile when delivered unless it is clearly labeled! If biopsy equipment is not sterile it is mandatory to clean and sterilize it before usage. For additional details please contact the legal manufacturer of the biopsy equipment.



Caution

Ensure the correct position and optimal fit every time before using a biopsy guide!



Caution

Ensure that the needle (especially the needle tip) is always visible in the ultrasound image during the whole biopsy procedure.



Caution

- Disposable biopsy guides: Single-use components must be disposed as infectious waste!
- Reusable biopsy guides must be sterilized before they are disposed!



Caution

Before starting a biopsy procedure with a 3D/4D probe always perform a volume scan first. This is important to ensure proper mechanical alignment and centering of the transducer element before the biopsy is performed.

Biopsy setup safety



Caution

- The default biopsy lines provided with the system software, must be verified at least once by the user. The procedure must be repeated if probes and/or biopsy guides are exchanged.
- Restored biopsy lines, must be verified at least once by the user. The procedure must be repeated if probes and/or biopsy guides are exchanged.
- Before performing a biopsy, prepare a water bath of approx. 47°C and make sure that the displayed biopsy line coincides with the needle track. Observe probe specific information on the temperature of the water bath.
- The needle used for water bath alignment must not be used for a biopsy performed on a patient.
- Depending on the needle stiffness/thickness and the elasticity and composition of the different tissue-types in the path of the biopsy needle, the actual needle track can deviate from the predicted biopsy line. The biopsy needle might bend and not follow a straight line.

Freehand biopsy



Caution

When performing a freehand biopsy, i.e. without a biopsy guide, it is the user's responsibility to use appropriate equipment.



Caution

Always only use basic modes when performing a freehand biopsy.

Note

A water bath alignment verification is also necessary before performing freehand biopsy procedures.

Reusable biopsy needle guides



For reprocessing of Biopsy Guides please refer to enclosed manuals.

5.4.2 Biopsy guide mounting

All biopsy needle guides can easily be mounted to the transducer. Biopsy guides have a special stop or handle to guarantee a good fix into the notch of transducers.

Before starting the exam, check the maximum force, torque and twist that can be applied without unintentionally detaching the biopsy guide from the ultrasound probe or damaging/deforming the biopsy guide.

Biopsy Guide Adjustment

How to adjust the biopsy needle on probes like i.e. RIC5-9-D, etc.:

1. Fill the sterile medical probe sheath with ultrasound gel and insert the probe in the medical probe sheath.
2. Install the sterilized biopsy guide on the covered probe.
 - a) Place the front ball of the biopsy guide onto the alignment recess of the probe shaft.
 - b) Apply minor pressure on the clip.
 - c) By keeping a) and b) install the biopsy guide on the probe shaft so that also the second ball aligns in the recess of the probe shaft. The clip has to encompass the shaft.

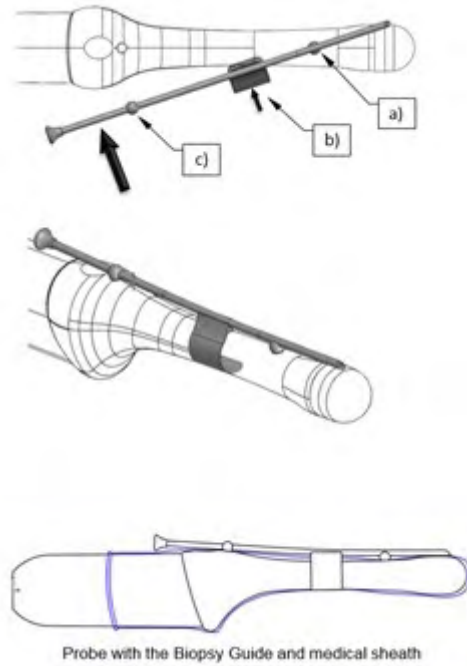

How to adjust the biopsy guide on probes like i.e. RAB6-D,....:

1. Fill the sterile medical probe sheath with ultrasound gel and insert the probe in the medical probe sheath.
2. Install the sterilized biopsy guide on the covered probe
 - a) Open the lever.
 - b) Apply the biopsy guide on the probe and ensure the knob in the biopsy fits over the alignment groove on the probe.
 - c) Move the spring into the groove.
 - d) Close the lever.

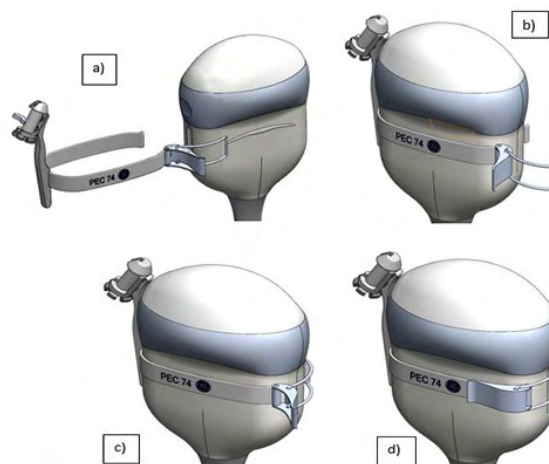

Technical data:

The reusable biopsy needle guides are of stainless steel type 301, 303 and 304 (AISI No).

Biopsy Guide Adjustment

Please refer to the manuals enclosed within the Biopsy Guides.

5.4.3 Biopsy setup



Before starting a biopsy please make sure that in case you want to save a study, all relevant patient information is entered.

Programming of Biopsy lines is done in the Biopsy Setup.

To invoke the Biopsy Setup:

To invoke the Biopsy Setup, 2D mode must be active.

1. Go to the **Home** menu.
2. Select **System Setup** and then **Biopsy Setup** on the touch panel.

Note *Biopsy Line buttons are greyed, if needle path was not calibrated once (Biopsy Setup).*

Biopsy kit name and the “Biopsy Line” buttons are dependent on the selected probe.

Preparation for biopsy line adjustment

Read all safety relevant information before performing and programming a biopsy.

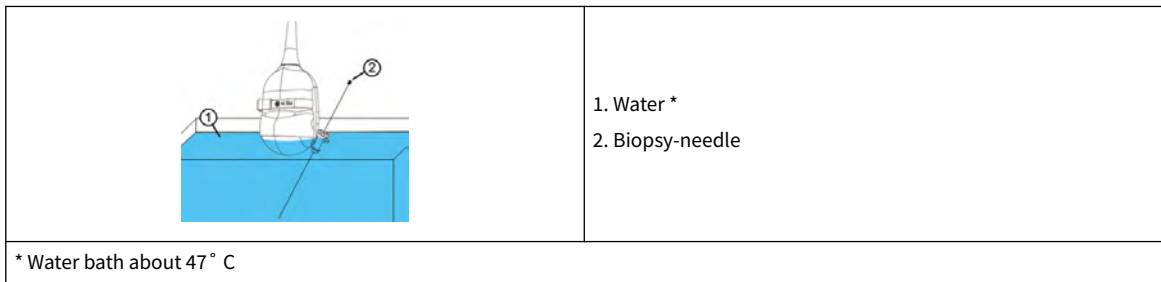

1. Mount the desired biopsy guide to a probe and attach the needle.
2. Connect the probe and select it on the touch panel.
3. Press **2D** on the user interface to activate B-Mode.
4. Place the probe into a water bath (**about 47° C, set OTI to “Normal!”**) and display the exact position of the needle on the active B image.
5. Go to the **Home** menu.
6. Select **System Setup**.
7. Press **Biopsy Setup** on the touch panel.
8. The Biopsy Setup Menu is displayed on the touch panel.

Note *A water bath alignment verification is also necessary before performing freehand biopsy procedures.*

5.4.3.1 Biopsy line adjustment for single angle biopsy guide

Storing a biopsy line

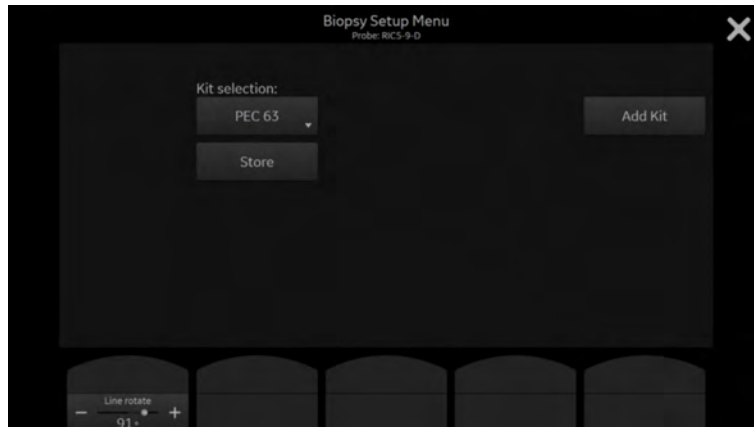

Figure 5-11 Biopsy Setup Menu: Single angle biopsy guide

1. Perform steps 1 to 8, see 'Biopsy setup' on page 5-28.
2. Select a biopsy kit.
3. The biopsy line is shown on the monitor screen.
4. Adjust the biopsy line by using the Trackball (**pos**) and the left rotary button below the touch panel (**Line rotate**).
5. Press **Store** to save the line.
6. Press **Exit** to close the Biopsy Setup.

Note *If the biopsy line was modified and not stored before **Exit** is pressed, a message box appears asking whether the changes should be discarded or not. **Yes** discards the changes and closes the biopsy setup, **No** closes the window and returns to the setup menu.*

5.4.3.2 Biopsy line adjustment for multi angle biopsy guide

Storing a biopsy line

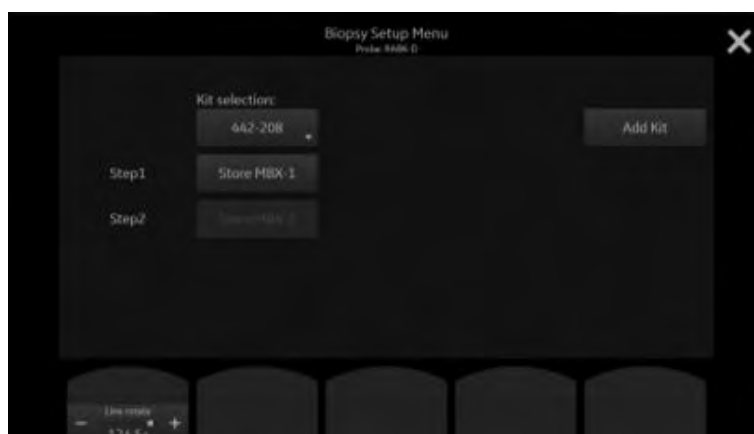

Figure 5-12 Biopsy Setup Menu: Multi angle biopsy guide

1. Set the biopsy guide angle to MBX-1.



Perform steps 1 to 8, see 'Biopsy setup' on page 5-28.

2. Select a biopsy kit.
3. The MBX-1 biopsy line is shown on the monitor screen.
4. Adjust the biopsy line by using the Trackball (**pos**) and the left rotary button below the touch panel (**Line rotate**).
5. Press **Store MBX-1** to save the MBX-1 line.
6. Set the biopsy guide angle to MBX-3.
7. Adjust the position of MBX-3 line and press **Store MBX-3**.
8. Press **Exit** to close the Biopsy Setup.
9. Biopsy line MBX-2 will be calculated and stored by the system.

Note *If the biopsy line was modified and not stored before **Exit** is pressed, a message box appears asking whether the changes should be discarded or not. **Yes** discards the changes and closes the biopsy setup, **No** closes the window and returns to the setup menu.*

5.4.3.3 Biopsy line adjustment for a user defined biopsy guide

Adding a biopsy kit

1. Perform steps 1 to 4, see 'Biopsy setup' on page 5-28.
2. Press **Add Kit** on the touch panel.
3. Assign a name to the biopsy kit.
4. A biopsy kit can have up to 3 biopsy lines.

Storing a biopsy line

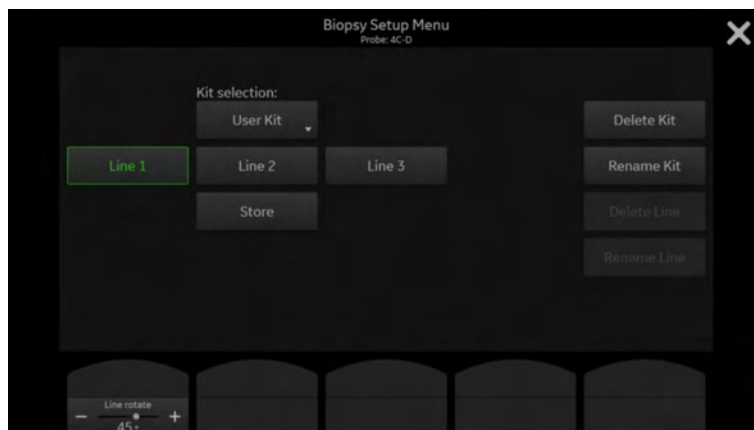

Figure 5-13 Biopsy Setup Menu: User defined biopsy guide

1. Perform steps 1 to 8, see 'Biopsy setup' on page 5-28.
2. Select a biopsy kit.
3. The biopsy line is shown on the monitor screen.
4. Adjust the biopsy line by using the Trackball (**pos**) and the touch control (**Line rotate**).
5. Press **Store** to save the line. Enter a new line name if desired.
6. Press **Exit** to close the Biopsy Setup.

Note *If the biopsy line was modified and not stored before **Exit** is pressed, a message box appears asking whether the changes should be discarded or not. **Yes** discards the changes and closes the biopsy setup, **No** closes the window and returns to the setup menu. If another biopsy kit is selected and the changes were not stored, a message box appears as well.*

Note *Biopsy kits can be deleted (**Delete Kit**) or renamed (**Rename Kit**).
Biopsy lines can be deleted (**Delete Line**) or renamed (**Rename Line**).*

5.4.3.4 β -View with Biopsy

It is possible to enable **β -View** using 3D/4D transvaginal probes while a biopsy line is enabled.

The icon displays the restricted **β -View** angle: 

Also see '2D Mode' on page 6-4



Note *Due to mechanical limitations a small change in the **β -View** angle may remain unnoticeable in the ultrasound image.*

5.5 Overview of all probes and biopsies

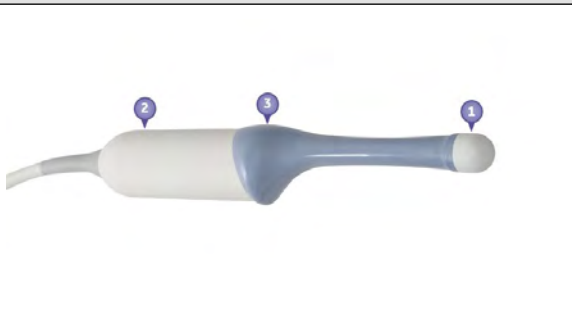

- Note** Please note that not all listed probes may be available at the time of release of these Instructions for Use.
- Note** Read all safety precautions before using a probe.
- Note** Please find more details about application features of every single probe in chapter 'Features' on page 5-23

5.5.1 3D/4D Probes: Curved Array (Convex) Probes

5.5.1.1 RIC5-9-D Endocavity transducer



RIC5-9-D		Biopsy PEC63	Biopsy 134-153
 <p>(1) Patient-applied part (2) Probe handle (3) Orientation marker</p>			
Clinical application specific settings	Features	Features	Features
<ul style="list-style-type: none"> • Transrectal • Gynecology • Obstetrics 	<ul style="list-style-type: none"> • 3D/4D Real Time imaging • Wide field of view • CFM, MCFM, HD-Flow™, Power, Tissue and PW Doppler • Broad bandwidth, Multi-frequency • Biopsy guide available 	<ul style="list-style-type: none"> • Needle diameters: < 1.8 mm • Material: Stainless Steel • Sterilization with autoclave possible! • For detailed information, please contact the manufacturer. 	<ul style="list-style-type: none"> • Needle diameters: > 1.2 mm < 1.6 mm • Material: Plastic • Sterile packaged component. • Single-Use only! • with latex cover • For detailed information, please contact the manufacturer.

5.5.1.2 RAB6-D



RAB6-D		Biopsy 442-208
 <p>(1) Patient-applied part (2) Probe handle (3) Orientation marker</p>		
Clinical application specific settings	Features	Features
<ul style="list-style-type: none"> Abdomen Obstetrics Pediatrics Gynecology 	<ul style="list-style-type: none"> 3D/4D Real Time imaging Wide field of view Small and light weight Biopsy guide available CFM, MCFM, HD-Flow™, Power, Tissue, PW and CW Doppler Broad bandwidth, Multi-frequency 	<ul style="list-style-type: none"> Only CIVCO (manufacturer) needle guides may be used with this biopsy. Material: Plastic Multi-angle biopsy Only the biopsy bracket is reusable. For detailed information, please contact the manufacturer.

5.5.2 2D Probes: Curved Array (Convex) Probes



5.5.2.1 C1-5-D Curved Array transducer

C1-5-D		Biopsy C1-5
 <p>(1) Patient-applied part (2) Probe handle</p>		
Clinical application specific settings	Features	Features
<ul style="list-style-type: none"> Abdomen Obstetrics Gynecology 	<ul style="list-style-type: none"> Wide field of view CFM, MCFM, HD-Flow™, Power, Tissue and PW Doppler Broad bandwidth, Multi-frequency Biopsy guide available 	<ul style="list-style-type: none"> Only CIVCO (manufacturer) needle guides may be used with this biopsy Material: Plastic Multi-angle biopsy Only the biopsy bracket is reusable For detailed information, please contact the manufacturer



5.5.2.2 C1-6-D Curved Array Transducer

C1-6-D		Biopsy
 <p>(1) Patient-applied part (2) Probe handle (3) Orientation marker</p>		
Clinical application specific settings	Features	Features
<ul style="list-style-type: none"> Abdomen Obstetrics Gynecology 	<ul style="list-style-type: none"> Wide field of view CFM, MCFM, HD-Flow™, Power, Tissue and PW Doppler Broad bandwidth, Multi-frequency steerable CW Doppler 	<ul style="list-style-type: none"> Only CIVCO (manufacturer) needle guides may be used with this biopsy. Material: Plastic Multi-angle biopsy Only the biopsy bracket is reusable. For detailed information, please contact the manufacturer.

5.5.2.3 C2-9-D Curved Array Transducer

C2-9-D		Biopsy
 <p>(1) Patient-applied part (2) Probe handle (3) Orientation marker</p>		
Clinical application specific settings	Features	Features
<ul style="list-style-type: none"> Abdomen Obstetrics Gynecology Pediatrics 	<ul style="list-style-type: none"> Wide field of view CFM, MCFM, HD-Flow™, Power, PW and CW Doppler Broad bandwidth, Multi-frequency 	<ul style="list-style-type: none"> Only CIVCO (manufacturer) needle guides may be used with this biopsy. Material: Plastic Multi-angle biopsy Only the biopsy bracket is reusable. For detailed information, please contact the manufacturer.

5.5.2.4 IC5-9-D Curved array transducer



IC5-9-D		Biopsy 134-125	Biopsy
 <p>(1) Patient-applied part (2) Probe handle (3) Orientation marker</p>			
Clinical application specific settings	Features	Features	Features
<ul style="list-style-type: none"> • Obstetrics • Gynecology • Transrectal 	<ul style="list-style-type: none"> • Wide field of view • Biopsy guide available • CFM, MCFM, HD-Flow™, Power and PW Doppler • Broad bandwidth, Multi-frequency 	<ul style="list-style-type: none"> • Needle diameters: ≤ 1.65 mm • Material: Stainless Steel • Sterilization with autoclave possible! 	<ul style="list-style-type: none"> • Needle diameter: 16 - 18GA (1.27 - 1.65 mm) • Material: Plastic • Sterile packaged component. • Single-Use only! • For detailed information, please contact the manufacturer.

5.5.3 2D Probes: Linear Array Probes

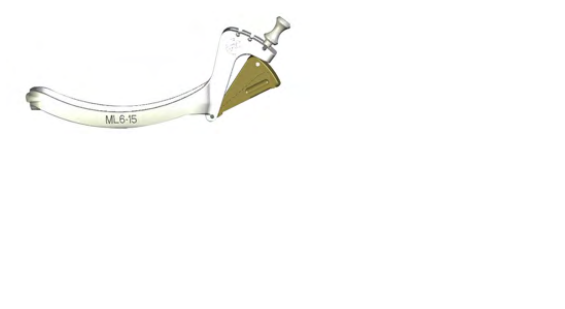

5.5.3.1 ML6-15-D Linear array transducer

ML6-15-D		Biopsy ML6-15
		
<p>(1) Patient-applied part (2) Probe handle (3) Orientation marker</p>		
Clinical application specific settings	Features	Features
<ul style="list-style-type: none"> • Small parts • Vascular • Pediatrics • MSK • Breast 	<ul style="list-style-type: none"> • Wide field of view (virtual convex) • CFM, HD-Flow™, Power and PW Doppler • Broad Bandwidth, Multi Frequency • Biopsy guide available • Matrix technology 	<ul style="list-style-type: none"> • Only CIVCO (manufacturer) needle guides may be used with this biopsy. • Material: Plastic • Multi-angle biopsy • Only the biopsy bracket is reusable. • For detailed information, please contact the manufacturer.

5.5.3.2 9L-D Linear array transducer

9L-D		Biopsy 9L
 <p>(1) Patient-applied part (2) Probe handle (3) Orientation marker</p>		
Clinical application specific settings	Features	Features
<ul style="list-style-type: none"> • Small parts • Obstetrics • Vascular • Pediatrics • MSK 	<ul style="list-style-type: none"> • Wide field of view (virtual convex) • CFM, Power and PW Doppler • steerable CW Doppler 	<ul style="list-style-type: none"> • Only CIVCO (manufacturer) needle guides may be used with this biopsy. • Material: Plastic • Multi-angle biopsy • Only the biopsy bracket is reusable. • For detailed information, please contact the manufacturer.

5.5.3.3 11L-D Linear array transducer

11L-D		Biopsy 11L/12L-RS
 <p>(1) Patient-applied part (2) Probe handle (3) Orientation marker</p>		
Clinical application specific settings	Features	Features
<ul style="list-style-type: none"> • Small parts • Vascular • Pediatrics • MSK • Breast 	<ul style="list-style-type: none"> • Wide field of view (virtual convex) • CFM, HD-Flow™, Power and PW Doppler 	<ul style="list-style-type: none"> • Only CIVCO (manufacturer) needle guides may be used with this biopsy. • Material: Plastic • Multi-angle biopsy • Only the biopsy bracket is reusable. • For detailed information, please contact the manufacturer.

5.5.4 2D Probes: Phased Array (Sector) Probes

5.5.4.1 M5Sc-D Phased array transducer

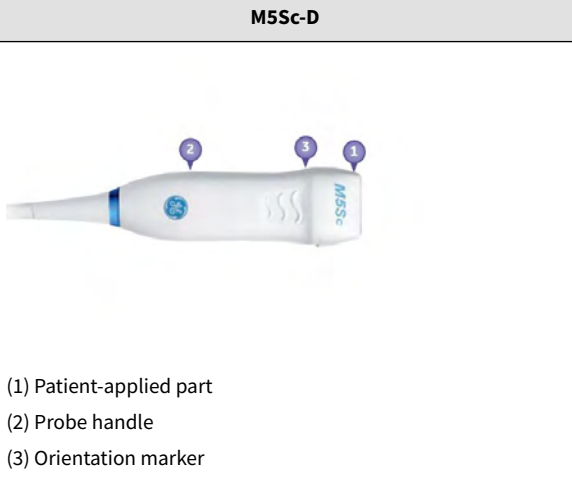
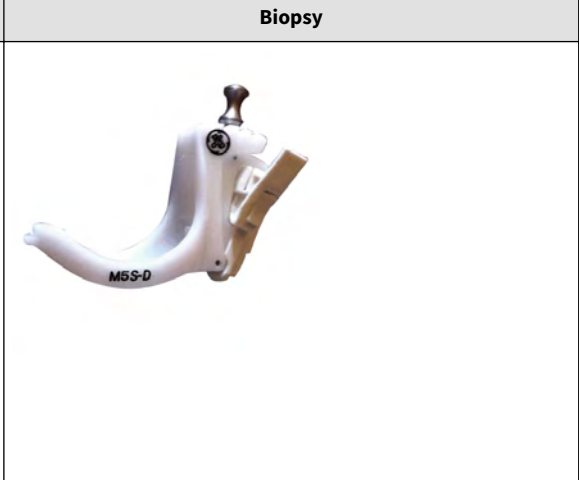
M5Sc-D		Biopsy
 <p>(1) Patient-applied part (2) Probe handle (3) Orientation marker</p>		
Clinical application specific settings	Features	Features
<ul style="list-style-type: none"> • Cardiology • Paediatrics • Cephalic 	<ul style="list-style-type: none"> • Harmonic Imaging • CFM, MCFM, HD-Flow™, Power, Tissue, PW Doppler • steerable CW Doppler 	<ul style="list-style-type: none"> • Only CIVCO (manufacturer) needle guides may be used with this biopsy. • Material: Plastic • Multi-angle biopsy • Only the biopsy bracket is reusable. • For detailed information, please contact the manufacturer.

Chapter 6

2D Mode

2D Mode screen display ----- 6-2
2D Mode standard features and modes ----- 6-4
2D Mode options ----- 6-24

In 2D Mode the ultrasound image is derived from the tissue echoes that return to the scan head. They are amplified, converted, and then mapped to an image processing curve that relates each echo's intensity to a shade of gray. The greater the echo intensity, the brighter the shade of gray. As each echo is received, it is arranged along a line within the ultrasound image display. The location along the line that is displayed is related to the depth at which the echo occurs.

2D Mode is the system's basic mode. It can be combined with various other modes.

6.1 2D Mode screen display

The 2D Mode screen display consists of the ultrasound image, an orientation marker, patient data, image information, a gray scale bar, a depth scale with focal zone markers, and a TGC curve.

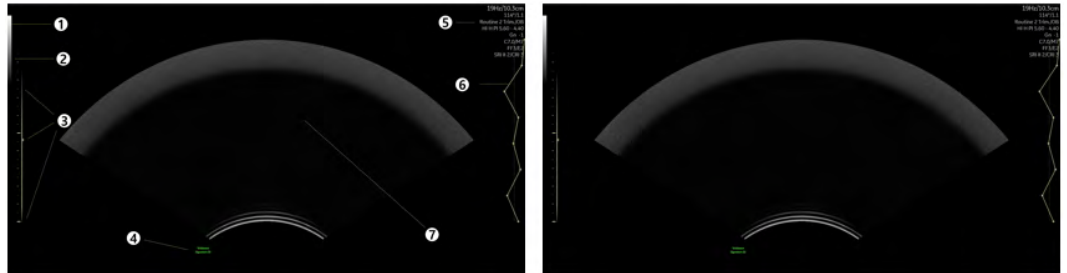

Figure 6-1 2D Mode screen display

Screen formats

Available screen formats in standard, XL and Fullscreen size are:

- Single
- Dual
- Quad

Note

*In frozen Dual format it is possible to switch to Full format and back to Dual format without losing the image. Press the Trackball **Fullx** to enlarge the selected Dual image x. To toggle between the Dual images, press the Trackball **Fullx/Dual**.*

Gray scale wedge

Screen reference: 1

The gray scale wedge represents all gray levels in the US image from bright to dark. The displayed pattern corresponds to the selected gray map in the 2D Sub Menu.

Depth scale marker

Screen reference: 2

The depth scale marker allows to determine the depth of the echoes or objects displayed in the ultrasound image on sent or printed images.

Three depth scale markers are available:

- Large marker: represents 5cm in depth
- Medium marker: represents 1cm in depth
- Small marker: represents 5mm in depth

Focal Zone marker

Screen reference: 3

A triangular marker next to the depth scale marks the middle of a focal zone of the ultrasound probe. The **Foc. Zones** touch panel control adjusts the number of focal zones. Use the dedicated control to move the focal position along the depth scale. The markers only represent the B-image focal zone(s). The number of focal zones and number of focal depth positions is dependent on the ultrasound probe.

Note

If a probe with a confocal marker is active, the Focal Zone marker is only displayed if selected within the System Setup or marked with a yellow area graphic.

Orientation marker

Screen reference: 4

The orientation marker identifies the left/right orientation of the scan plane on screen in relation to the left/right side of the scan head (ultrasound probe). The housing of a probe has a mechanical scan plane indicator which corresponds to the orientation marker on screen.

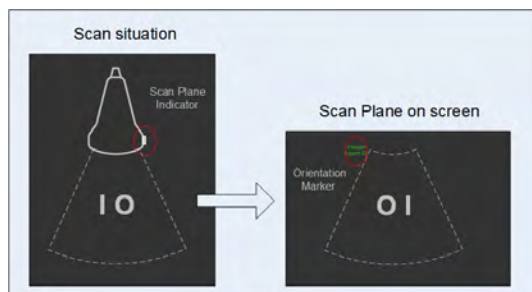

Figure 6-2 Orientation marker

Image info

Screen reference: 5

Display examples	Description
21Hz/7.0cm	Frame Rate / Image Depth Length
150°/1.3	Scan Angle / Magnification Factor
User Preset/Application	Name of the user Preset/ Name of user program application setting
P, N, R	Receiver Frequency: P = Penet, N = Norm, R = Resol
HI x (PI*)	Receiver Frequency: HI = Harmonic Imaging, x = L(ow), M(id), H(igh), PI*=puls inversion (probe and application dependent), Augment
SR X xx-xx.x	Shadow Reduction (SR) on; (X: HI M, xx-xx.x: bandwidth)
Gn 2	B-Mode Gain [dB]
C7/M5 C7/CM1	Dynamic Contrast (C1 - C12) / Gray map number Dynamic Contrast (C1 - C12) / Gray map number
P6/E4 FF4/E3	Persistence / Edge enhancement Frame Filter / Edge enhancement
S./PRI 4.0	Display of Sensitivity and Pulsed Repetition Index in B-Flow and Contrast Mode
SRI II 3/CRI 3	Speckle Reduction Imaging Filter/ Compound Resolution Imaging Filter

Table 6-1 Image info

TGC curve

Screen reference: 6

The time gain compensation curve (TGC), located to the right of the image display, graphically corresponds to the time gain compensation that is applied by the system. The TGC graphic on the screen correlates to the TGC slider positions on the touch panel (projection to vertical US-line).

Ultrasound image

Screen reference: 7

6.2 2D Mode standard features and modes

This chapter describes standard features and modes available in 2D Mode.

All standard feature menus consist of a **Main Menu** and **Sub Menu**. The main panel area can be customized individually. Therefore the images displayed here are for illustrative purposes only and may be different from what is displayed on the screen or device.

6.2.1 2D Mode

B-Mode is intended to provide two-dimensional images and measurement capabilities concerning the anatomical structure of soft tissue.

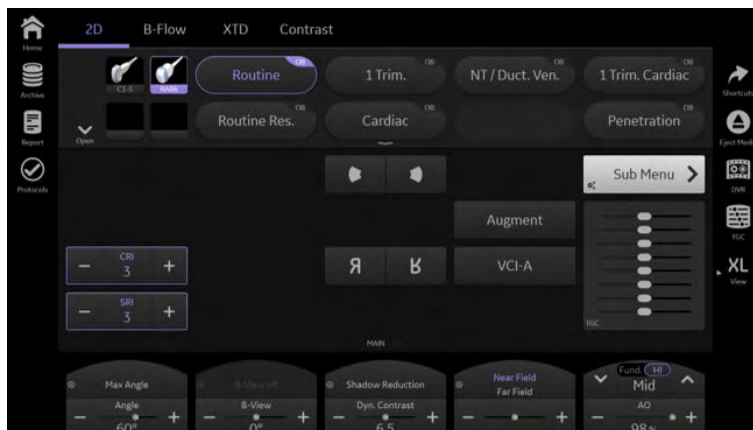



Figure 6-3 2D Mode (example)

Controls

- CRI** Opens Compound Resolution Imaging. Compound Resolution Imaging is the process of combining three or more frames from different steering angles into a single frame. It is available on convex and linear probes.
- SRI** Speckle Reduction Imaging (SRI) is an adaptive algorithm to reduce the unwanted effects of speckle in the ultrasound image. Image speckle usually appears as a grainy texture in otherwise uniform areas of tissue. Its appearance is related to image system characteristics, rather than tissue characteristics, so that changes in system settings, such as probe type, frequency, depth, and others, can change the appearance of the speckle. Too much speckle can impair image quality and make it difficult to see the desired detail in the image. Likewise, too much filtering of speckle can mask or obscure desired image detail. Extra care must be taken to select the optimal SRI level. SRI is available in B-Mode imaging and may be used with any transducer or clinical application when image speckle appears to interfere with the desired image detail.
- Sub Menu** Opens the **Sub Menu** menu.
-  Select the desired shortcuts from the **Shortcuts** menu.
- 2D+2D/SRI** Provides a comparison of images on the screen with and without **SRI** activated. This button is not available with **CRI**.
- TGC Sliders** The time gain compensation (TGC) curve graphically corresponds to the time gain compensation that is applied by the system.
- Tap onto the **TGC** button to open the **TGC** menu. Adjust the sliders as desired or press **Reset** or double tap on the **TGC** menu to set them all back to middle position. **Show Image** displays the current live image (single view only).
- Near Field** and **Far Field** gain can also be adjusted. Using the slope function: When **Near Field** (Slope Start) or **Far Field** (Slope End) is adjusted, all sliders are changed with a linear factor so that the position to each other is kept in a relative way.
- Screen Format** Available in standard, XL View and fullscreen.

Display Format

Single, Dual or Quad format.



The Lt/Rt/Up/Down plane orientation button toggles the plane orientation.

Frame Filter

Frame Filter is a frame averaging function that allows elimination of image speckle from 2D images. Frame Filter is only available if CRI is activated.

Angle

Image Angle allows the selection of a part of interest of the 2D image. The advantage of the decreased field of view is an increased 2D frame rate due to the smaller sector width.

Dynamic Contrast

Dynamic Contrast controls how echo intensities are converted to shades of gray, thereby increasing the adjustable range of contrast.

Acoustic Output

Adjusts the **Acoustic Output**.

Cine Speed

Regulates the replay speed of the cine.

Harmonic / Fundamental

Adjusts the **Frequency** and **Harmonic Imaging**. The corresponding hardkey control or touch panel control allows to circle between all frequencies in harmonics and fundamentals.

Augment

Enables scanning for a more clear image with less noise in difficult scanning conditions.

Shadow Reduction

This algorithm reduces shadowing artifacts and is application dependent. When **Shadow Reduction** is turned off, the last used frequency is activated again.

VCI-A

This function allows a direct/quick access from B-Mode to 4D VCI-A run mode without using the 4Dpre mode.

Gray Map

The **Gray Map** determines the displayed brightness of an echo in relationship to its amplitude. Depending on individual requirements a “harder” or “softer” image can be obtained with this function and can be adjusted in freeze and in scan mode (post-processing).

Tint Map

Displays the tint map selections on the monitor.

Line Filter

Line Filter smoothens the image in the direction parallel to the probe surface (or in a curve).

Line Dens.

Line Density optimizes B-Mode frame rate or spatial resolution for the best possible image. It allows to make a trade-off between image resolution and frame rate.

Persist.

Persistence is a frame averaging function that allows elimination of image speckle from 2D images. With a higher persistence setting more frames are averaged (only available when CRI is off).

Enhance

Edge Enhance brings out subtle tissue differences and boundaries by enhancing the gray scale differences corresponding to the edges of structures. A fine, sharper impression of the image is produced.

Reject

Rejection selects a level below which echoes will not be amplified (an echo must have a certain minimum amplitude before it will be processed). It determines the amplitude threshold above which ultrasound echoes are displayed on screen.

OTI

Optimize Tissue Imaging (OTI) allows to fine tune the system for scanning different kinds of tissue depending on the patients. Use the OTI control to adjust the respective parameter. Four positions are possible: adipose, solid, cystic or normal tissue.

CRI Filter

Filter types: low, mid, high

Virtual Convex

Increases the scan area by steering the ultrasound lines on the edge of the probe.

BPP Clock

Starts and pauses a timer for the BPP (Biophysical Profile). A long press resets the clock to zero.

Note Only available in Obstetrics.



β-View

Rotate the image 90 or 270°. The depth scale and the focus marker (if visible) are also rotated. Flipping the rotated image up/down is not possible.

Note *When the mode is changed the rotation is discarded.*

The ***β-View*** function allows to tilt the acoustic block of the probe electronically without tilting the probe housing manually. This is a big advantage if the probe cannot be tilted manually like in transvaginal scanning. The ***β-View*** icon on screen shows the position

range and the current position with help of a green line in the icon: 

Note *This function is probe dependent and not available in 3D/4D modes.*

Rotate the control to adjust the ***β-View*** angle and press the control to deactivate ***β-View***.

Also see 'β-View with Biopsy' on page 5-31

Trackball Controls

<i>Change</i>	Toggles between <i>pos</i> and ...
<i>pos</i>	If activated, the position of the 2D image can be changed.
<i>...</i>	If activated, the position of the 2D image is locked and cannot be changed.
<i>Update 2D</i>	Updates the 2D image (only available in Dual and Quad format).
<i>Full x / Dual</i>	Toggles between <i>Full x</i> and <i>Dual</i> (only available in Dual format).
<i>Cine</i>	Manual cine stepper.
<i>Edit Cine</i>	Change trackball state to edit cine mode.

Using 2D-Mode

1. Connect a probe to the system.
2. Start a new exam and enter all relevant patient information.
3. Select the probe and a preset.
4. The ***Main 2D*** menu appears on the touch panel.
5. Perform the scan.
6. Press ***Freeze***.

Hint *To change 2D Gain rotate the ***2D*** encoder.*

Info *Also see 'Button description' on page 3-6.*

Cine gaps

If data-interruption occurred during scanning, this  icon appears in the left upper corner when the cine cursor is 0.5sec before or after the marked cine gap (missing frames). However, in case that also a time-trace (e.g. PW-trace) is displayed, the cine gap (missing frames) is additionally indicated in the time-trace. It is possible to perform measurements across the cine gap (available for all modes except XTD and 3D).

6.2.2 Color Flow Mode and Tissue Doppler Mode

Color Flow Mode (CFM) is a Doppler Mode intended to add color coded qualitative information concerning the relative velocity and direction of fluid motion within the B-Mode image.

Color Flow (CF) is useful to see flow in a broad area. Color Flow allows visualization of flow in the CF ROI, whereas Doppler Mode provides spectral information in a smaller area.

Color Flow is also sometimes used as a stepping stone to Doppler. You use Color Flow to locate flow and vessels prior to activating Doppler.

Tissue-Doppler (TD) imaging generates a Color image by using the Doppler principle. This Color image is overlaid onto the 2D image. The Tissue image provides information about tissue motion direction and velocity.

The Tissue-Doppler captures low flow but high amplitude signals associated with wall motion and creates a color-coded tissue image.

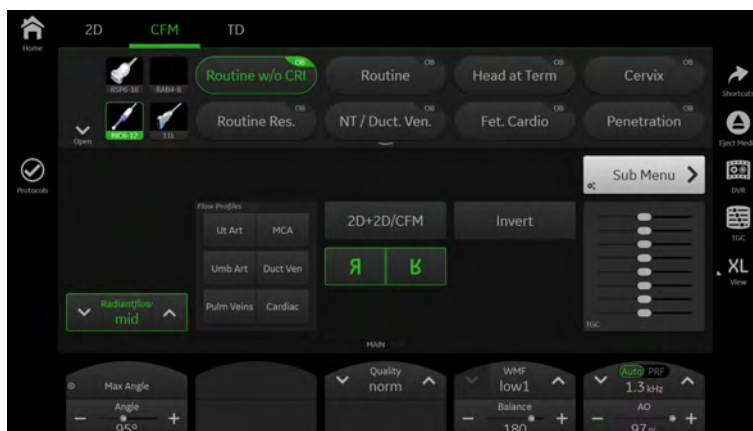

Figure 6-4 CFM Mode (example)

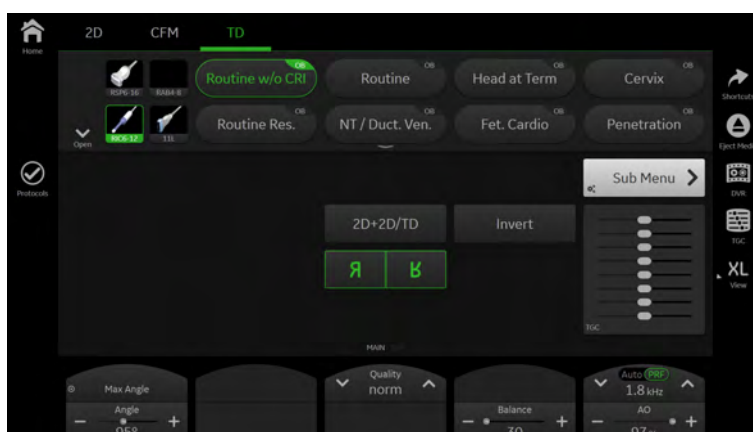

Figure 6-5 TD Mode (example)

Controls

2D + 2D/CFM	Displays 2D and color image side by side.
Radiantflow	Activates/deactivates Radiantflow . Radiantflow makes the edges of the color information of the image more gradient. Select between Off , Min , Mid and Max in the sub menu.
2D + 2D/TD	Displays 2D and TD image side by side.
Steering	The steering angle value changes from plus to minus and vice versa. (linear probe only)
Steer Flip	Flip the steering direction.
Invert	This function inverts the spectrum display in relation to the direction of flow. The displayed spectrum is inverted around the baseline. The velocity or frequency scale changes accordingly. Use Invert when necessary to change the spectral display orientation. It is possible in both freeze and scan mode.
Sub Menu	Opens the Sub Menu menu.
Angle	Image Angle selects a part of interest of the 2D image. The advantage of the decreased field of view is an increased 2D frame rate due to the smaller sector width.
Quality	The higher the color resolution, the lower the frame rate. Available settings: high, norm and low.

B-Mode Quality	Improves the quality of the B-image while using color.
Balance	Balance establishes the amount of color displayed over bright echoes and helps confine color within the vessel walls. Raising this balance displays color on brighter structures. If you see color on vessel walls, the balance is probably set too high. Additionally, wall motion ghosting can be suppressed with a low balance setting.
Acoustic Output	Adjusts the Acoustic Output .
PRF	The Pulse Repetition Frequency (PRF) has direct influence on the velocity range. The higher the Pulse Repetition Frequency the lower the velocity range. As the display scale increases, the maximum Doppler shift information that can be displayed without aliasing also increases. Aliasing is where the blood velocity exceeds the maximum measurable velocity, causing the displayed flow within the vessel to portray flow in the wrong direction. The disadvantage of using a higher PRF is a loss of sensitivity to low flow velocities.
Threshold	This function is only available in Frozen state or after pressing Freeze. It eliminates small color noise or motion artifact signals in the color image. It is similar to the Gain control in Scan Mode.
Color Off	This function is only available in Frozen state. It turns off color display.
WMF	The Wall Motion Filter eliminates vessel wall motion noise that is low in velocity but high in intensity. Use a wall filter that is high enough to remove motion artifacts, but that is sensitive enough to display low velocity flows in small vessels. Available settings: low1, low2, mid1, mid2, high1, high2, max1 and max2.
Auto	Press Auto to change the PRF by an algorithm dynamically, depending on the CFM box size and position to stabilize the velocity scale/frame rate. It is possible to adjust the PRF manually while Auto is active. TGC and Gain can be adapted through pressing Auto .
	Note <i>Availability depends on probe.</i>
Ensemble	This function controls the number of pulses for one displayed line. Since several pulses are to be evaluated for displaying a result, the color display quality increases with the number of evaluated pulses. With increasing Ensemble the frame rate decreases.
Displ. Mode	Display Mode
CFM Map	This function allows selection of the color-coding for the blood flow display (similar to the post-processing curves with gray scale 2D). It is useful especially with low flow rates. It may be altered in Scan or Freeze Mode.
TD Map	This function allows to select the color-coding for an optimization of the display of motion (similar to the post-processing curves with gray scale 2D). It may be altered in Scan or Freeze mode, respectively.
TGC Sliders	The time gain compensation (TGC) curve graphically corresponds to the time gain compensation that is applied by the system. Tap onto the TGC button to open the TGC menu. Adjust the sliders as desired or press Reset to set them all back to middle position. Show Image displays the current live image (single view only).
Lt/Rt	The Lt/Rt plane orientation button toggles the plane orientation.
Units	Select between 3 different scale units (KHz , cm/s , m/s).
Cine Speed	Regulates the replay speed of the cine.
HI	Switch between the two functions HI and Frequency by tapping onto the button once.
Line Filter	Line Filter smoothes the image in the direction parallel to the probe surface (or in a curve).
Artefact	Artefact eliminates artefacts of probe movements. Select between following values: <ul style="list-style-type: none"> ● Off ● Mid ● High

Smooth Fall	Smoothing performs a temporal averaging which improves the appearance of the color images. Different amounts of smoothing can be selected for rising velocity and falling velocity. Filtering of the fall velocity leads to prolongation of the displayed flow. Usage with quick pulses (short "color flashes") prolongates the flow for better evaluation on the monitor.
Smooth Rise	Smoothing performs a temporal averaging which improves the appearance of the color images. Different amounts of smoothing can be selected for rising velocity and falling velocity. Filtering of the rise velocity leads to noise suppression. To be used with small laminar flows. Avoid quick movements of the probe, because the flow is "built up" slowly. When displaying pulses the Rise Filter must be set low.
Line Dens.	Line Density optimizes B-Mode frame rate or spatial resolution for the best possible image. It allows to make a trade-off between image resolution and frame rate.
Baseline	Baseline can be used to prevent aliasing in one flow direction similar to the PW Doppler baseline shift. Shifting the baseline enlarges the velocity range in one direction. The zero line of the color bar is also shifted.
Center Frq.	Transmitting frequency of the CFM beam. (low/mid/high)
Flow Res.	Flow Resolution controls the axial resolution of color in the display. It adjusts the axial sample depth of color pixels.
Flow Profiles	<p>Select between the following Flow Profiles:</p> <ul style="list-style-type: none"> ● Ut Art ● MCA ● Umb Art ● Duct Ven ● Pulm Veins ● Cardiac <p>Depending on the System Setup settings the following values are set:</p> <ul style="list-style-type: none"> ● PRF (only valid when manual PRF is active; if Auto Scale is active, the PRF values are set dynamically) ● WMF ● Gain Offset <p>Only one button can be active at the same time. Pressing the button again deactivates it. Use Flow Profiles for optimizing vessel flow representation scanning.</p> <p>Note Flow Profiles are only available for OB probe applications.</p>

Trackball Controls

Change	Toggles between C-pos and C-size
C-pos	If activated, the position of the color box/ TD box can be changed.
C-size	If activated, the size of the color box/ TD box can be adjusted.
Update 2D	Updates the 2D image (only available in Dual and Quad format).
Full x / Dual	Toggles between Full x and Dual (only available in Dual format).

Using Color Flow Mode

1. Press **2D** on the user interface to start B-Mode.
2. Press **C** on the user interface to start Color Flow Mode.
3. The **Main CFM** menu appears on the touch panel.
4. Press the top trackball button (**Change**) and adjust size and position of the Color box with the trackball.
5. Press **Freeze**.

Hint To change Color Gain rotate the **C** button. To change the frequency / PRF / WMF use the touch panel control or the according hardkey control.

Info Also see 'Button description' on page 3-6.

Using TD Mode

1. Press **2D** on the user interface to start B-Mode.
2. Press **C** on the user interface to start Color Flow Mode.
3. Press **TD** on the touch panel to start TD Mode.
4. The **Main TD** menu appears on the touch panel.
5. Press the top trackball button (**Change**) and adjust size and position of the TD box with the trackball.
6. Press **Freeze**.

Note The availability of some functions or features depends on the probe and ultrasound system used.

Info Also see 'Button description' on page 3-6.

6.2.3 Power Doppler Mode and HD-Flow™

Power Doppler (PD) is a color flow mapping technique used to map the strength of the Doppler signal coming from the flow rather than the frequency shift of the signal. Using this technique, the ultrasound system plots color flow based on the number of reflectors that are moving, regardless of their velocity. Power Doppler does not map velocity, therefore it is not subject to aliasing.

High-Definition Flow (HD-Flow™) is a directional Power Doppler Mode incorporating the flow direction into the displayed image. The focus of the settings for HD-Flow™ is on high spatial resolution and low artefact visibility, allowing vessels to be seen with less blooming and finer detail.

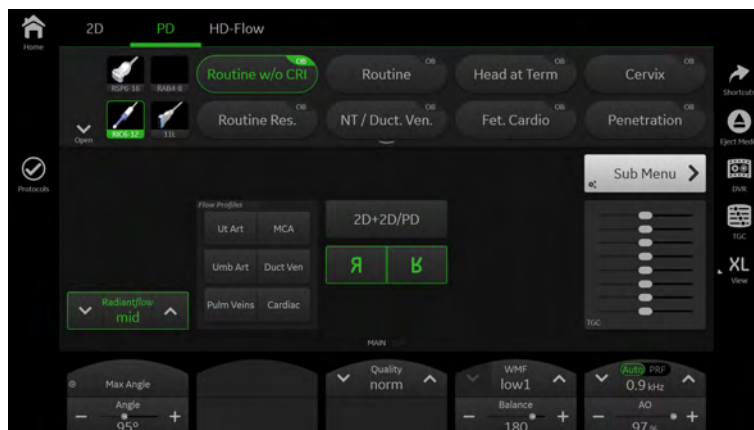

Figure 6-6 PD-Mode (example)

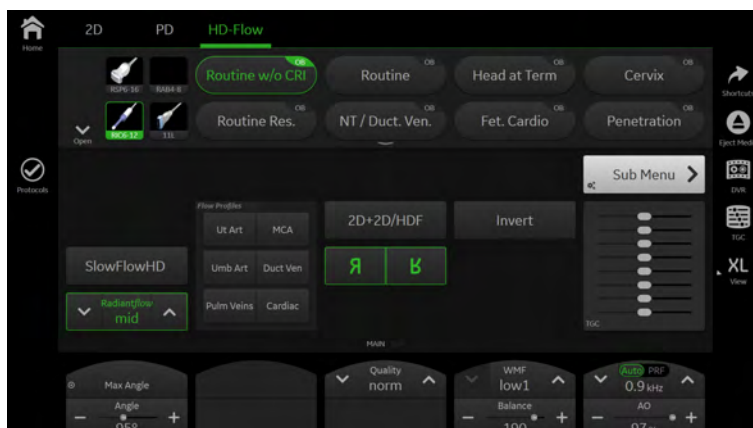

Figure 6-7 HD-Flow™ Mode (example)

Controls

2D + 2D/ PD	Displays 2D and PD image side by side.
2D + 2D/ HD	Displays 2D and HD-Flow™ image side by side.
SlowFlowHD	<p>Activates/deactivates SlowFlowHD. In blood flow detection a typical issue is the corruption of the data with low-frequency tissue motion (clutter). Thus, in traditional color and power Doppler technologies the low-frequency components are suppressed by the Wall-Motion-Filter (WMF). The suppression of the low-frequency tissue components also causes a suppression of low-frequency flow components. To overcome this issue, a feasible separation between tissue motion and blood flow has to be applied. SlowFlowHD is able to suppress the low-frequency clutter motion while preserving the flow information. Details are displayed in the image info. The PRF is dependent on the size and the position of the color box. If the color box or size is changed, the PRF changes accordingly. Press Background in the sub menu to reduce the grey information in the background. Select between Off (grey information completely removed), Low, Mid and On in the displayed popup window.</p> <p>As soon as SlowFlowHD is activated, the submenu changes slightly, e.g. Artefact can be adjusted as desired (Off, Low, Mid, High) to eliminate artefacts caused by probe movements. Smooth replaces Smooth Fall and Smooth Rise. When SlowFlowHD is deactivated, the previously used values are displayed again.</p> <p>Note SlowflowHD is an option and probe dependent.</p> <p>Note SlowflowHD is called Slowflow3D in 3D/4D modes.</p>
Radiantflow	Activates/deactivates Radiantflow . Radiantflow makes the edges of the color information of the image more gradient. Select between Off , Min , Mid and Max in the sub menu.
Invert	This function inverts the spectrum display in relation to the direction of flow. The displayed spectrum is inverted around the baseline. The velocity or frequency scale changes accordingly. Use Invert when necessary to change the spectral display orientation. It is possible in both freeze and scan mode.
Sub Menu	Opens the Sub Menu .
Quality	The higher the color resolution, the lower the frame rate. Available settings: high, norm and low.
Balance	Balance establishes the amount of color displayed over bright echoes and helps confine color within the vessel walls. Raising this balance displays color on brighter structures. If you see color on vessel walls, the balance is probably set too high. Additionally, wall motion ghosting can be suppressed with a low balance setting.
WMF	The Wall motion filter eliminates vessel wall motion noise that is low in velocity but high in intensity. Use a wall filter that is high enough to remove motion artifacts, but that is sensitive enough to display low velocity flows in small vessels. Available settings: low1, low2, mid1, mid2, high1, high2 and max.

Acoustic Output	Adjusts the Acoustic Output .
PRF	The Pulse Repetition Frequency (PRF) has direct influence on the velocity range. The higher the Pulse Repetition Frequency the lower the velocity range. As the display scale increases, the maximum Doppler shift information that can be displayed without aliasing also increases. Aliasing is where the blood velocity exceeds the maximum measurable velocity, causing the displayed flow within the vessel to portray flow in the wrong direction. The disadvantage of using a higher PRF is a loss of sensitivity to low flow velocities.
Steering	The steering angle value changes from plus to minus and vice versa. (linear probe only)
Color Off	This function is only available in Read Mode. It turns off color display.
Threshold	This function assigns the gray scale level at which color information stops.
Auto	Press Auto to change the PRF by an algorithm dynamically, depending on the CFM box size and position to stabilize the velocity scale/frame rate. It is possible to adjust the PRF manually while Auto is active. Note <i>Availability depends on probe.</i>
HI	Switch between the two functions HI and Frequency by tapping onto the button once.
Harmonic / Fundamental	Adjusts the Frequency and Harmonic Imaging .
TGC Sliders	The time gain compensation (TGC) curve graphically corresponds to the time gain compensation that is applied by the system. Tap onto the TGC button to open the TGC menu. Adjust the sliders as desired or press Reset to set them all back to middle position. Show Image displays the current live image (single view only).
Lt/Rt	The Lt/Rt plane orientation button toggles the plane orientation.
PD/HDF Map	Displays the PD or HD-Flow™ Map.
Units	Select between 3 different scale units (kHz , cm/s , m/s).
Flow Res.	Flow Resolution controls the axial resolution of color in the display. It adjusts the axial sample depth of color pixels.
Line Filter	With Line Filter , the signals of neighboring pulses are less weighted for the image which improves detail resolution and signal-to-noise ratio. Especially the lateral resolution can be optimized with this correlation algorithm.
Line Dens.	Line Density optimizes B-Mode frame rate or spatial resolution for the best possible image. It allows to make a trade-off between image resolution and frame rate.
Ensemble	This function controls the number of pulses for one displayed line. Since several pulses are to be evaluated for displaying a result, the color display quality increases with the number of evaluated pulses. With increasing Ensemble the frame rate decreases.
Smooth Fall	Smoothing performs a temporal averaging which improves the appearance of the color images. Different amounts of smoothing can be selected for rising velocity and falling velocity. Filtering of the fall velocity leads to prolongation of the displayed flow. Usage with quick pulses (short "color flashes") prolongates the flow for better evaluation on the monitor.
Smooth Rise	Smoothing performs a temporal averaging which improves the appearance of the color images. Different amounts of smoothing can be selected for rising velocity and falling velocity. Filtering of the rise velocity leads to noise suppression. To be used with small laminar flows. Avoid quick movements of the probe, because the flow is "built up" slowly. When displaying pulses the Rise Filter must be set low.

Artefact	Artefact eliminates artefacts of probe movements. Select between following values: <ul style="list-style-type: none"> ● Off ● Mid ● High
Flow Profiles	Select between the following Flow Profiles : <ul style="list-style-type: none"> ● Ut Art ● MCA ● Umb Art ● Duct Ven ● Pulm Veins ● Cardiac <p>Depending on the System Setup settings the following values are set:</p> <ul style="list-style-type: none"> ● PRF (only valid when manual PRF is active; if Auto Scale is active, the PRF values are set dynamically) ● WMF ● Gain Offset <p>Only one button can be active at the same time. Pressing the button again deactivates it. Use Flow Profiles for optimizing vessel flow representation scanning.</p> <p>Note <i>Flow Profiles are only available for OB and Fetal Cardio probe applications.</i></p> <p>Note <i>It is possible to reorder the measurement buttons within the box as desired. Press onto the configuration symbol to select between Configuration (enables the touch menu configuration for the measurement box) and Back to Default (restores the factory configuration).</i></p>

Trackball Controls

Change	Toggles between C-pos and C-size
C-pos	If activated, the position of the color box can be changed.
C-size	If activated, the size of the color box can be adjusted.
Update 2D	Updates the 2D image (only available in Dual and Quad format).
Full x / Dual	Toggles between Full x and Dual (only available in Dual format).

Using PD-Mode

1. Press **2D** on the user interface to start B-Mode.
2. Press **PD** on the user interface to start Power Doppler Mode.
3. The **Main PD** menu appears on the touch panel.
4. Press **Freeze**.

Using HD-Flow™

1. Press **2D** on the user interface to start B-Mode.
2. Press **PD** on the user interface to start Power Doppler Mode.
3. Press **HD-Flow** on the touch panel to start HD-Flow™.
4. The **Main HD-Flow** menu appears on the touch panel.
5. Press **Freeze**.

Hint	To change PD /HD-Flow™ Gain rotate the corresponding button.
Info	Also see 'Button description' on page 3-6.
Note	The availability of some functions or features depends on the probe and ultrasound system used.
Info	Also see '2D Mode' on page 6-4 and 'Button description' on page 3-6.

6.2.4 B-Flow

B-Flow helps to visualize complex hemodynamics and highlights moving structures or blood. It is visually intuitive when viewing blood flow, for acute thrombosis, parenchymal flow and jets. It is a realistic (intuitive) representation of flow information, allowing to view both high and low velocity flow at the same time.

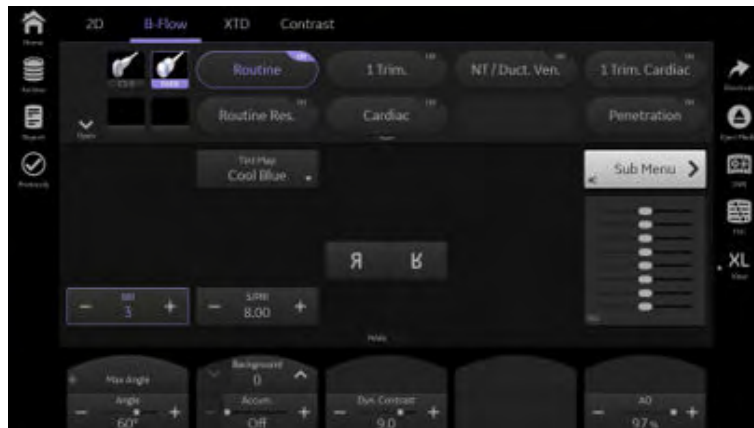

Figure 6-8 B-Flow Mode (example)

Controls

SRI	Speckle Reduction Imaging (SRI) is an adaptive algorithm to reduce the unwanted effects of speckle in the ultrasound image. Image speckle usually appears as a grainy texture in otherwise uniform areas of tissue. Its appearance is related to image system characteristics, rather than tissue characteristics, so that changes in system settings, such as probe type, frequency, depth, and others, can change the appearance of the speckle. Too much speckle can impair image quality and make it difficult to see the desired detail in the image. Likewise, too much filtering of speckle can mask or obscure desired image detail. Extra care must be taken to select the optimal SRI level. SRI is available in B-Mode imaging and may be used with any transducer or clinical application when image speckle appears to interfere with the desired image detail.
Virtual Convex	Increases the scan area by steering the ultrasound lines on the edge of the probe.
Sub Menu	Opens the Sub Menu .
Angle	Image Angle selects a part of interest of the 2D image. The advantage of the decreased field of view is an increased 2D frame rate due to the smaller sector width.
Accumulation	Accumulation enhances the displayed flow in an image.
TGC Sliders	The time gain compensation (TGC) curve graphically corresponds to the time gain compensation that is applied by the system. Tap onto the TGC button to open the TGC menu. Adjust the sliders as desired or press Reset to set them all back to middle position. Show Image displays the current live image (single view only).
Lt/Rt	The Lt/Rt plane orientation button toggles the plane orientation.
Cine Speed	Regulates the replay speed of the cine.
Dyn. Contr.	Dynamic Contrast controls how echo intensities are converted to shades of gray, thereby increasing the adjustable range of contrast.

Acoustic Output	Adjusts the Acoustic Output .
Background	Adjusts the level of the background anatomy.
Gray Map	The Gray Map determines the displayed brightness of an echo in relationship to its amplitude. Depending on individual requirements a “harder” or “softer” image can be obtained with this function and can be adjusted in freeze and in scan mode (post-processing).
Tint Map	Displays the tint map selections on the monitor.
Persist.	Persistence is a frame averaging function that allows elimination of image speckle from 2D images. With a higher persistence setting more frames are averaged.
Enhance	Edge Enhance brings out subtle tissue differences and boundaries by enhancing the gray scale differences corresponding to the edges of structures. A fine, sharper impression of the image is produced.
Line Density	Line Density optimizes B-Mode frame rate or spatial resolution for the best possible image. It allows to make a trade-off between image resolution and frame rate.
S/PRI	Sensitivity Pulsed Repetition Index; a higher value improves the B-Flow image

Trackball Controls

Change	Toggles between pos and ...
pos	If activated, the position of the 2D image can be changed.
...	If activated, the position of the 2D image is locked and cannot be changed.
Image/Cine	Toggles between Image and Cine mode
Update 2D	Updates the 2D image (only available in Dual and Quad format).
Full x / Dual	Toggles between Full x and Dual (only available in Dual format).

Using B-Flow

1. Press **2D** on the user interface to start B-Mode.
2. Press **B-Flow** on the touch panel to start B-Flow Mode.
3. The main **B-Flow** menu appears on the touch panel.

Info Also see 'Button description' on page 3-6.

6.2.5 M-Mode

M-Mode is intended to provide a display format and measurement capability that represents tissue displacement (motion) occurring over time along a single vector.

M-Mode is used to determine patterns of motion for objects within the ultrasound beam. The most common use is for viewing motion patterns of the heart.

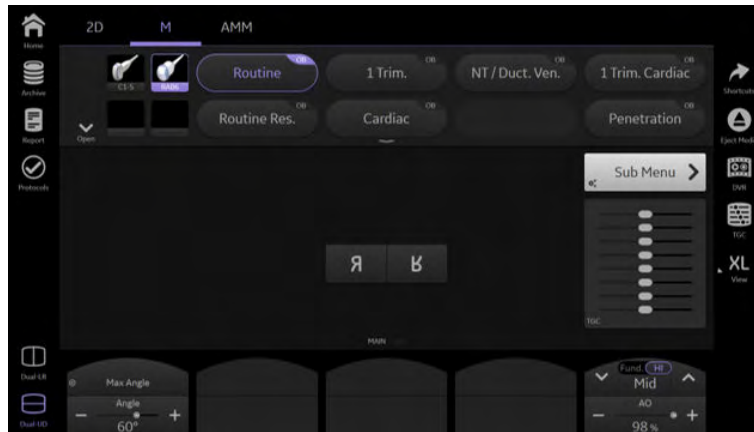

Figure 6-9 M-Mode (example)

Controls

Sub Menu	Opens the Sub Menu .
M Down/Up	Inverts the motion image from Up to Down.
Sweep Speed	Changes the speed at which the timeline is swept.
40/60, 50/50, 60/40	With the controls 40/60, 50/50 and 60/40 the size between B image and motion image can be adjusted.
Angle	Image Angle selects a part of interest of the 2D image. The advantage of the decreased field of view is an increased 2D frame rate due to the smaller sector width. Note <i>A tap on Max Angle gives you the maximum angle of the selected probe.</i>
Dyn. Contr.	Dynamic Contrast controls how echo intensities are converted to shades of gray, thereby increasing the adjustable range of contrast.
Acoustic Output	Adjusts the Acoustic Output .
Harmonic / Fundamental	Adjusts the Frequency and Harmonic Imaging .
Lt/Rt	The Lt/Rt plane orientation button toggles the plane orientation.
TGC Sliders	The time gain compensation (TGC) curve graphically corresponds to the time gain compensation that is applied by the system. Tap onto the TGC button to open the TGC menu. Adjust the sliders as desired or press Reset to set them all back to middle position. Show Image displays the current live image (single view only).
Enhance	Edge Enhance brings out subtle tissue differences and boundaries by enhancing the gray scale differences corresponding to the edges of structures. A fine, sharper impression of the image is produced.
Reject	Rejection selects a level below which echoes will not be amplified (an echo must have a certain minimum amplitude before it will be processed). It determines the amplitude threshold above which ultrasound echoes are displayed on screen.
B/M-Mode Quality	Turn it on to improve the image quality (Cave: decreases frame rate). Note <i>Change dual format from left-right (LR) to up-down (UD) and vice versa through the touch panel control (lower left side menu)</i>
Display Formats	Switch between Dual LR (Format vertical) and Dual UD (Format horizontal).

Trackball Controls

Change	Toggles between Cursor and Loop
Cursor	Activates the Cursor .

Image / Cine	Switches between image and cine controls. If Image is active, it is possible to navigate through the Cine with the trackball.
Loop	Activates the Loop .
2D / M run	Updates the 2D image (only available in Dual and Quad format).
Pos	If activated, the position of the M image can be changed.

Using M-Mode

1. Press **2D** on the user interface to start B-Mode.
2. Press **M** on the user interface to start M-Mode.
3. The **M Main** menu appears on the touch panel.
4. Place the cursor line over the region of interest.
5. Press **2D/M run** (right or left trackball button).
6. Press **Freeze**.

Hint *To change M Gain rotate the **M**-button. To change the Frequency use the adjacent encoder below the touch panel.*

Info *Also see 'Button description' on page 3-6. For the option AMM (Anatomical M-Mode) please see 'Anatomical M-Mode (AMM)' on page 6-37.*

Note *The availability of some functions or features depends on the probe and ultrasound system used.*

When M Mode is combined with the color modes **M CFM** or **M HDflow**, **Radiantflow** is available.

Radiantflow	Note Radiantflow is an option.
	Activates/deactivates Radiantflow . Radiantflow makes the edges of the color information of the image more gradient. Select between Off , Min , Mid and Max in the sub menu.

Cine gaps

If a data-interruption occurs during motion mode the cine gap is indicated by blue lines at the top and bottom in the M-image. If the cine gap occurs for a sufficiently long time also this  icon is displayed within the marked gap. It is possible to perform measurements across the cine gap.

6.2.6 Pulsed Wave Doppler (PW)

Doppler imaging includes a spectral analysis which describes the Doppler shift signal from the moving reflectors within a sample volume. The spectral display scrolls from left to right and depicts the spectral distribution of the components of the Doppler shift frequency over time. Frequency or velocity values appear on the vertical axis and time along the horizontal axis. Component amplitudes appear as shades of gray. The brighter the shade, the higher the amplitude. The Doppler display can be used alone, but it is normally used with a 2D image. The 2D image contains a Doppler cursor that defines the location of the Doppler ultrasound beam relative to the 2D image display. The flow direction cursor can be aligned with the direction of flow within the vessel to determine the Doppler angle. The system uses the Doppler angle to calibrate the Doppler velocity display. When the Doppler frequency display is used, the frequency display is not calibrated to account for the Doppler angle. The Doppler display consists of the following: the spectral analysis display of the ultrasound data, patient data and identification, image information, a gray scale map, a velocity or frequency scale, and a time scale. A sample volume cursor is located on the PW cursor and it indicates where, along the ultrasound beam, the spectral analysis is being performed. A flow direction cursor can be added to the sample volume.

PW Doppler is typically used for displaying the speed, direction, and spectral content of blood flow and information.

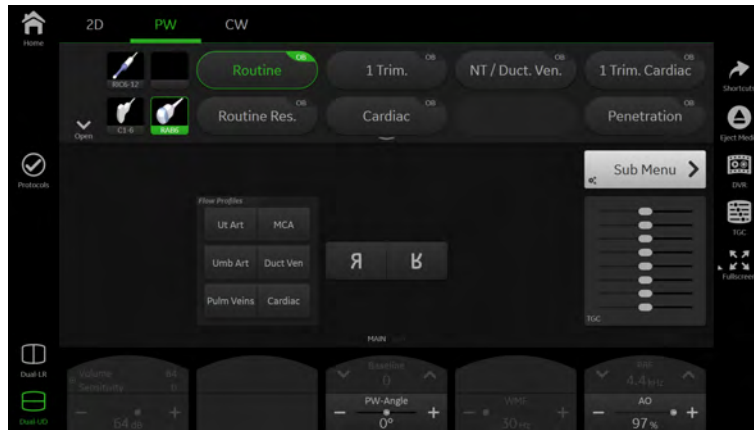

Figure 6-10 PW-Mode (example)

Controls

RT Trace	Real Time Trace on/off. When RT Trace is on, the spectral envelope curve, the TAMEAN curve and the corresponding measurement results are displayed. Select the Trace Mode channel for the envelope curve (upper , lower or auto).
Sensitivity	Select the sensitivity of the envelope curve (only available when RT Trace is active).
Steering	Change the steering angle. Beam steering creates ultrasound beams that are not perpendicular to the surface of the probe. This allows getting Doppler signals from flows that run parallel to the probe's surface.
Steer Flip	Press Steer Flip to flip the PW cursor position round the vertical axis. The steering angle value changes from plus to minus and vice versa.
Sweep Speed	Changes the speed at which the timeline is swept.
Cine Speed	Regulates the replay speed of the cine.
TGC Sliders	The time gain compensation (TGC) curve graphically corresponds to the time gain compensation that is applied by the system. Tap onto the TGC button to open the TGC menu. Adjust the sliders as desired or press Reset to set them all back to middle position. Show Image displays the current live image (single view only).
Invert	This function inverts the spectrum display in relation to the direction of flow. The displayed spectrum is inverted around the baseline. The velocity or frequency scale changes accordingly. Use Invert when necessary to change the spectral display orientation. It is possible in both freeze and scan mode.
Baseline	Baseline can be used to prevent aliasing in one flow direction similar to the PW Doppler baseline shift. Shifting the baseline enlarges the velocity range in one direction. The zero line of the color bar is also shifted.
PW Angle	Angle correction. The blood flow velocity calculation based on the incident angle of the ultrasound onto the axis of the vessel can be determined this way.
WMF	The Wall motion filter eliminates vessel wall motion noise that is low in velocity but high in intensity. Use a wall filter that is high enough to remove motion artifacts, but that is sensitive enough to display low velocity flows in small vessels. Available settings: 500, 300, 210, 160, 120, 90, 60, 30 Hz
PRF	The Pulse Repetition Frequency (PRF) has direct influence on the velocity range. The higher the Pulse Repetition Frequency the lower the velocity range. As the display scale increases, the maximum Doppler shift information that can be displayed without aliasing also increases. Aliasing is where the blood velocity exceeds the maximum measurable velocity, causing the displayed flow within the vessel to portray flow in the wrong direction. The disadvantage of using a higher PRF is a loss of sensitivity to low flow velocities.

Allow HPRF	If Allow HPRF is on it is possible to enter the HPRF mode.
Volume	PW Doppler audio volume. Volume Select the desired volume.
SRI	Enables/disables SRI on the motion image.
Sub Menu	Opens the Sub Menu menu.
Acoustic Output	Adjusts the Acoustic Output .
Gray Map	The Gray Map determines the displayed brightness of an echo in relationship to its amplitude. Depending on individual requirements a “harder” or “softer” image can be obtained with this function and can be adjusted in freeze and in scan mode (post-processing).
Tint Map	Displays the tint map selections on the monitor.
Units	Select between 3 different scale units (KHz, cm/s, m/s).
Dyn. Contr.	Dynamic Contrast controls how echo intensities are converted to shades of gray, thereby increasing the adjustable range of contrast.
Center Frequency	Sets the transmit frequency of the probe.
B/PW motion format	Dual V and Dual H switch the B Image and PW timeline from vertical to horizontal split screen and vice a versa. Additional with 60 / 40, 50 / 50, 40 / 60 control can be the B Image and PW timeline size adjusted.
Flow Profiles	Select between the following Flow Profiles : <ul style="list-style-type: none"> ● Ut Art ● MCA ● Umb Art ● Duct Ven ● Pulm Veins ● Cardiac <p>Depending on the System Setup settings the following values are set:</p> <ul style="list-style-type: none"> ● PRF ● WMF update ● WMF simult ● Baseline ● Gate size ● Sweep Speed ● R/R (Rt/Lt) <p>Only one button can be active at the same time. Pressing the button again deactivates it. Use Flow Profiles for optimizing vessel flow representation scanning.</p> <p>Note <i>Flow Profiles are only available for OB and Fetal Cardio probe applications.</i></p> <p>Note <i>It is possible to reorder the measurement buttons within the box as desired. Press onto the configuration symbol to select between Configuration (enables the touch menu configuration for the measurement box) and Back to Default (restores the factory configuration).</i></p>

Trackball Controls

Change	Toggles between G-pos and G-size or Cursor / Cine and Loop .
G-pos	If activated, the position of the PW cursor can be changed.
G-size	If activated, the size of the PW gate can be selected.

Update	The PW spectrum is started in update mode.
Simult	The PW spectrum is started in simultaneous mode.
-60/0/60	Toggles the SV angle between -60, 0 and 60.
Image/Cine	Toggles between Image and Cine mode.
Play/Stop	Replays the PW spectrum in Cine mode.
Set Start / End	Starts/ends the currently selected image.

Using PW Doppler

1. Press **2D** on the user interface to start 2D-Mode.
2. Optimize the B-Mode image.
3. Press **PW** on the user interface to start PW Doppler Mode.
4. The **PW Main** menu appears on the touch panel.

Hint *To change PW Gain rotate the **PW**-encoder (run and read mode).*

Info *Also see '2D Mode' on page 6-4 and 'Button description' on page 3-6.*

Cine gaps

If a data-interruption occurs during PW mode the cine gap is indicated by blue lines at the top and bottom in the PW-image. If the cine gap occurs for a sufficiently long time also this  icon is displayed within the marked gap. It is possible to perform measurements across the cine gap.

6.2.7 Extended View (XTD-View)

XTD-View provides the ability to construct and view a static 2D image which is wider than the field of view of a given transducer. This feature allows for viewing and measurement of anatomy that is larger than a regular screen.

XTD-View constructs an extended image from individual image frames as the operator slides the transducer along the surface of the skin. The probe is oriented parallel to the direction of motion throughout the scan. The quality of the result is user-dependent and requires some additional skills and practice to develop proper technique and become fully proficient. Examples include scanning of vascular structures and connective tissue in the arms and legs.

Note *Read 'Operation safety' on page 2-21 before using this feature.*

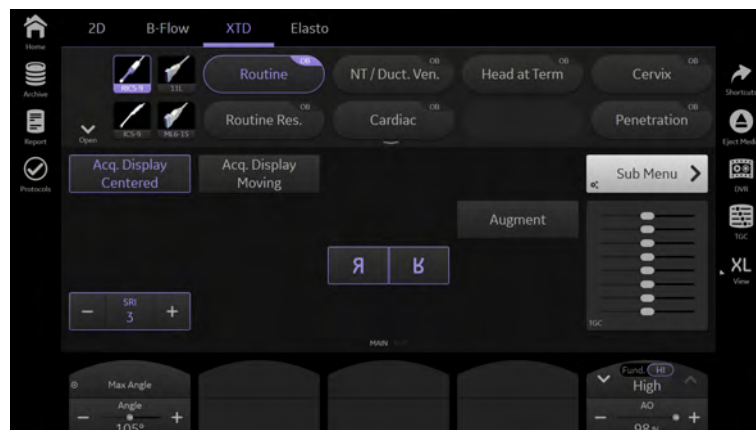

Figure 6-11 XTD-View pre Mode (example)

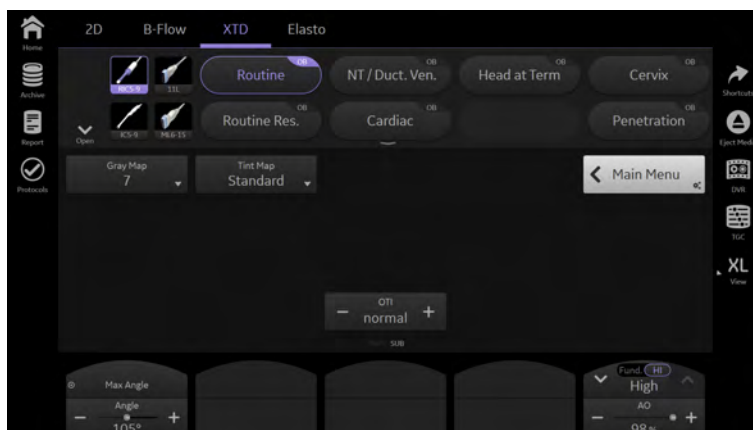



Figure 6-12 XTD-View Main Mode (example)

Controls

Centered	Set write mode to display the fixed 2D image.
Moving	Set write mode to display the moving 2D image.
Sub Menu	Opens the Sub Menu .
Angle	Image Angle selects a part of interest of the 2D image. The advantage of the decreased field of view is an increased 2D frame rate due to the smaller sector width. Note A tap on Max Angle gives you the maximum angle of the selected probe.
Frequency / Harmonic Imaging	Adjusts the Frequency and Harmonic Imaging . Switch between the two functions by tapping onto the button once.
Acoustic Output	Adjusts the Acoustic Output .
SRI	Speckle Reduction Imaging (SRI) is an adaptive algorithm to reduce the unwanted effects of speckle in the ultrasound image. Image speckle usually appears as a grainy texture in otherwise uniform areas of tissue. Its appearance is related to image system characteristics, rather than tissue characteristics, so that changes in system settings, such as probe type, frequency, depth, and others, can change the appearance of the speckle. Too much speckle can impair image quality and make it difficult to see the desired detail in the image. Likewise, too much filtering of speckle can mask or obscure desired image detail. Extra care must be taken to select the optimal SRI level. SRI is available in B-Mode imaging and may be used with any transducer or clinical application when image speckle appears to interfere with the desired image detail.
Ruler	Allows to determine the depth of the echoes or objects displayed in the ultrasound image on send/printed images.
Gray Map	The Gray Map determines the displayed brightness of an echo in relationship to its amplitude. Depending on individual requirements a “harder” or “softer” image can be obtained with this function and can be adjusted in freeze and in scan mode (post-processing).
Tint Map	Displays the tint map selections on the monitor.
OTI	Optimize Tissue Imaging (OTI) allows to fine tune the system for scanning different kinds of tissue depending on the patients. Use the OTI control to adjust the respective parameter. Four positions are possible: adipose, solid, cystic or normal tissue.
Fit/Overscan	Adjust the image size. With Fit the whole XTD View is visible. Overscan shows the center of the image, but maybe it crops some information.
Virtual Convex	Increases the scan area by steering the ultrasound lines on the edge of the probe.
	The Lt/Rt plane orientation button toggles the plane orientation.
XTD Rotation	Allows to rotate the 2nd image in frozen state.

Trackball Controls

Start	Starts the acquisition.
Stop	Stops the acquisition.
XTD pre	Goes back to pre mode.
Change	Toggle between (image locked) and Pos (image positioning).

Using XTD-View

1. Press **2D** on the user interface to start 2D Mode.
2. Optimize the B-Mode image.
3. Press **XTD** on the touch panel to start Extended View.
4. The **XTD pre** menu appears on the touch panel.
5. A blue box appears on the screen display.
6. Start the XTD acquisition with the trackball button **Start**.
7. Stop the image with **Stop** on trackballkey or **Freeze**.

Info Also see '2D Mode' on page 6-4 and 'Button description' on page 3-6.

6.2.8 2D Mode - Lung Setting

For scanning the lung, the specific setting has to be activated.

Note For safety information see 'Interpretation of displayed parameters MI and TI' on page 2-36

1. Connect an appropriate probe to the system (e.g. C2-9-D, C1-6-D, 11L-D, ML6-15-D, 9L-D).
2. Select the probe.
3. Select the appropriate application **Pediatrics** or **Abdomen**. The preset is marked with the corresponding lung logo.
4. Select **Lung** setting.
5. Perform the scan of the lung.

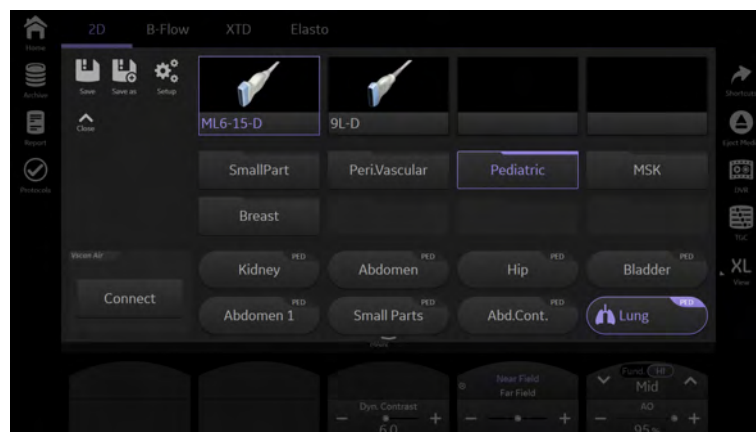

Figure 6-13 Lung setting (example)

6.2.9 2D Mode - Ophthalmic Artery Setting

For scanning the ophthalmic artery through the closed eye, the specific setting has to be activated.

Note For safety information see 'Interpretation of displayed parameters MI and TI' on page 2-36

Note *Ophthalmic may not be available in all countries.*

1. Connect an appropriate linear probe to the system (e.g. 9L-D).
2. Select the probe.
3. Select the Maternal Obstetric folder. The preset is marked with the corresponding ophthalmic artery logo.
4. Select the **Ophthalm. A.** setting.
5. Perform the scan of the ophthalmic artery only through the **closed** eye.

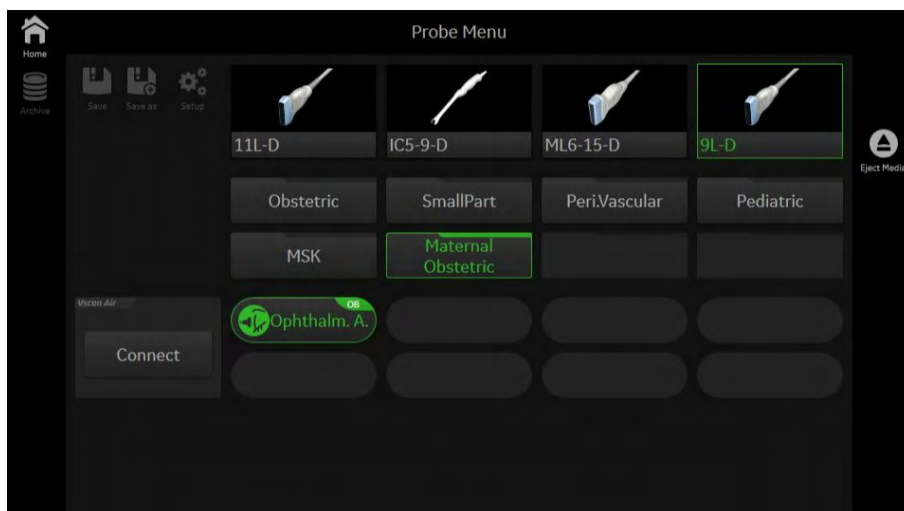

Figure 6-14 Ophthalmic Artery setting (example)

6.3 2D Mode options

The options described in this chapter are not available in all countries or need specific upgrades.

Note *Read all safety precautions before using this system.*

6.3.1 Elasto

Elastography shows the spatial distribution of tissue elasticity properties in a region of interest by estimating the strain before and after tissue distortion caused by external or internal forces. The strain estimation is filtered and scaled to provide a smooth presentation when displayed.



Caution

The results achieved in Elastography Mode always depend on the precision of the procedure performed. Any clinically relevant decisions need to be verified with other state of the art methods.

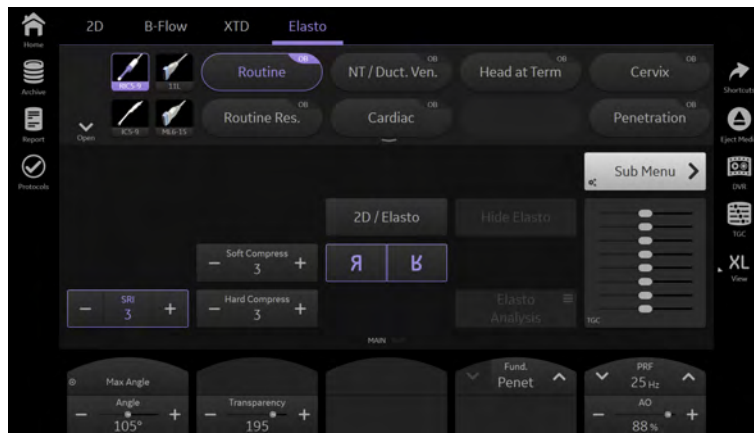

Figure 6-15 Elasto Mode (example)

Controls

SRI

Speckle Reduction Imaging (SRI) is an adaptive algorithm to reduce the unwanted effects of speckle in the ultrasound image. Image speckle usually appears as a grainy texture in otherwise uniform areas of tissue. Its appearance is related to image system characteristics, rather than tissue characteristics, so that changes in system settings, such as probe type, frequency, depth, and others, can change the appearance of the speckle. Too much speckle can impair image quality and make it difficult to see the desired detail in the image. Likewise, too much filtering of speckle can mask or obscure desired image detail. Extra care must be taken to select the optimal SRI level. SRI is available in B-Mode imaging and may be used with any transducer or clinical application when image speckle appears to interfere with the desired image detail.

Soft Compress.

Plus/minus control, range: 0-9 (step size: 1)

Hard Compress.

Plus/minus control, range: 0-9 (step size: 1)

2D + 2D/Elasto

Displays a 2D and an Elasto image side by side.

Sub Menu

Opens the **Sub Menu**.

Hide Elasto

Hides Elasto.

Angle

Image Angle selects a part of interest of the 2D image. The advantage of the decreased field of view is an increased 2D frame rate due to the smaller sector width.

Transp.

Adjust the transparency.

PRF	The Pulse Repetition Frequency (PRF) has direct influence on the velocity range. The higher the Pulse Repetition Frequency the lower the velocity range. As the display scale increases, the maximum Doppler shift information that can be displayed without aliasing also increases. Aliasing is where the blood velocity exceeds the maximum measurable velocity, causing the displayed flow within the vessel to portray flow in the wrong direction. The disadvantage of using a higher PRF is a loss of sensitivity to low flow velocities.
Acoustic Output	Adjusts the Acoustic Output .
Fund. (Frequency)	Adjusts the Frequency between Penet. , Normal and Resolution .
Cine Speed	Regulates the replay speed of the cine.
Elasto Map	Displays the elasto map selections on the screen.
Window Length	Window length, Range: 8-25 (step size: 1)
Window Step	Window step, Range: 1-max (max = 0.8* current Window Length) (Step size: 1)
Frame Reject	Frame Reject, Range: 0-255 (step size: 5)
Pixel Reject	Pixel Reject, Range: 0-255 (Step size: 5)
Persistence	Allows elimination of image speckle from 2D images.
Filter Axial	Filter Axial, Range: 1-9 (step size: 1)
Filter Lateral	Filter Lateral, Range: 1-21 (Step size: 2)
Line Dens.	Line Density optimizes B-Mode frame rate or spatial resolution for the best possible image. It allows to make a trade-off between image resolution and frame rate.
Threshold	Adapts the Threshold (low and high).
Quality Curve	Turns the display of the Quality Curve on or off.

Using Elastography

1. Press **2D** on the touch panel to start B-Mode.
2. Press **Elasto** on the touch panel to start Elastography.
3. Perform the scan. Proper manual compression/decompression is indicated by a fully green quality bar.
4. Press **Freeze**.

6.3.1.1 Elastography Analysis

The Elastography Mode detects strains by correlating the echo amplitudes of the tissue when compressed and uncompressed. Different displacement of echoes is an indicator for different stiffness (strain) of the tissue. High strain means that the tissue is softer, low strain means that it is stiffer. Zero is absolutely stiff without any elasticity. Elastography Analysis is a strain ratio comparative tool that enables users to compare the strain of one tissue to the surrounding tissue.

Using Elastography Analysis

1. If not yet in Elastography Mode press **Elasto** on the touch panel.
2. Perform the scan. Proper manual compression/decompression is indicated by a fully green quality bar.
3. Press **Freeze**.
4. Press **Elastography Analysis** on the touch panel. The Elastography Analysis touch panel menu appears and the monitor screen shows the **Elastography Analysis** display. The valid Elastography frames are marked green.
5. Adjust start and end of the Cine Loop within the green frames using the rotary buttons below the touch panel (**Start Frame/End Frame**). Press **Set** to confirm.

6. Activate the cursor and move it over the Elastography image on the top left side of the screen. A yellow Region of Interest (ROI) appears. By default this ROI is a circle. It will be the reference ROI and should be placed in the normal tissue.
7. Position this reference ROI and press **Set**. A yellow plot curve displays the strains over time on the right side of the monitor screen.
8. Move the trackball again. A new ROI appears (ROI 1) which should be placed in the lesion.
9. Position the ROI and press **Set**. A second plot curve is displayed (blue curve).
10. In total you can create 3 Region of Interests and 1 Reference Region of Interest. Each ROI can be edited or deleted. A ROI can also be drawn manually.
 - To edit a ROI move the cursor over it until 2 yellow crosses appear along the circle. Change the size and position of the ROI by using the trackball buttons **Edit Size / Edit Pos**. The diameter of the ROI is displayed below the circle.

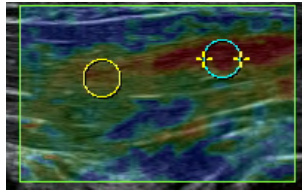

Figure 6-16 Editing a ROI

- To delete a ROI move the cursor over it and press **Selected** on the touch panel. To delete all ROIs press **All** on the touch panel.
- To draw a ROI manually press **Trace** on the touch panel and draw a shape. The position of this shape can be edited (**Edit Pos**).

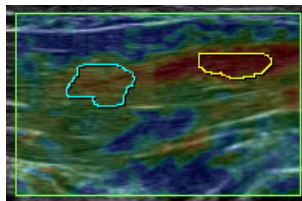

Figure 6-17 Hand-drawn ROI (Trace)

11. The following plots can be displayed: **Strain, Ratio** or **Strain & Ratio**
 - Press **Strain** to display the strain plot curves of the ROIs.
 - Press **Strain & Ratio** to see a combined view of the Strain and Ratio plot curves.
 - Press **Ratio** to display the ROIs proportionally to the Reference ROI.
12. Press **Exit** to get back to Elastography Mode.

Hint Use the trackball to scroll the Cine Loop quickly.

- Info**
- A small strain value indicates small compression.
 - The maximum strain value in human tissue can be up to 2%.
 - The ratio value indicates how many times the tissue of a ROI is harder or softer than the tissue of the Reference ROI.

Touch panel

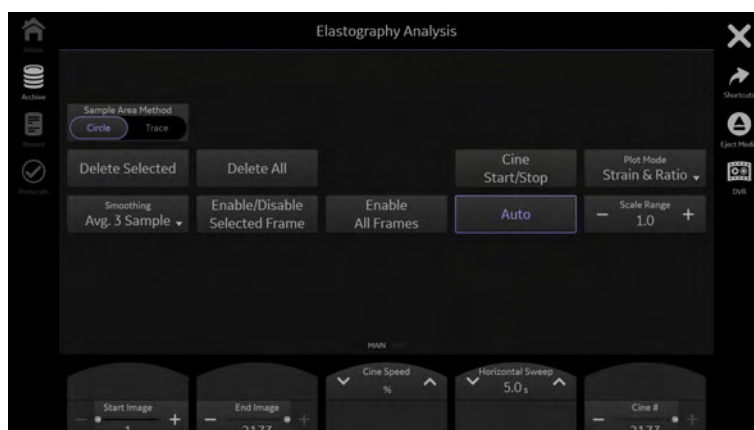
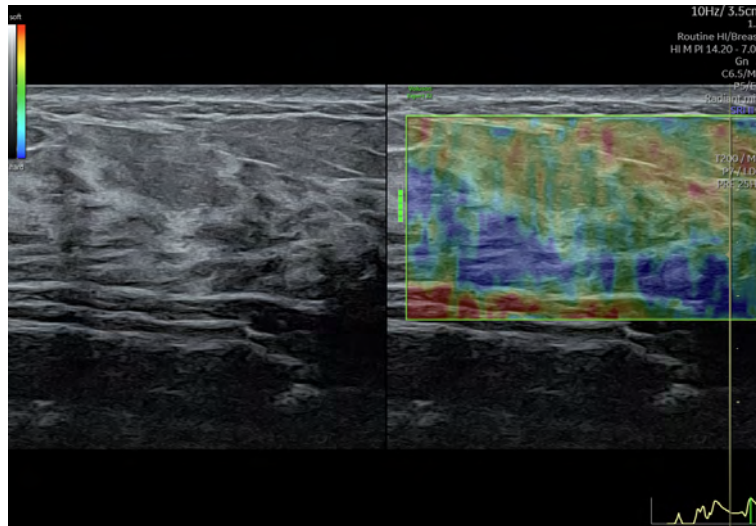

Figure 6-18 Touch panel: Elastography Analysis (example)

Sample Area Method	Select between the Circle and the Trace drawing tool.
Delete Selected	Delete the selected Region of Interest (ROI).
Delete All	Delete all Regions of Interest (ROIs).
Enable/Disable Selected Frame	Enable or disable the selected frame (invalid frames will be displayed as a dotted line in the plot curve).
Enable All Frames	Enable all disabled frames (invalid frames will be displayed as non-existing values).
Plot Mode	Select between Strain (single plot image with strain data), Ratio (single plot image with ratio data) and Ratio & Strain (dual plot image: upper image with strain data, lower image with ratio data).
Smoothing	Select between Off (no filter), Average [ms] (average filter over time) and Average Samples (average filter over a certain number of frames). Press Set as default to store the current filter position as default position.
Scale Range	Adjust the scale range manually as desired.
Auto	Automatically adjust the scale range.
Cine Start/Stop	Start/Stop the cine.
Start Image	Select the desired Start Image .
End Image	Select the desired End Image .
Speed	Loop speed: 25%, 50%, 100%, 200%; 100% corresponds to real time speed.
Horizontal Sweep	Adjust the time scale of the horizontal plot axis.
Cine #	Move from one cine frame to the other

Elastography monitor display



Elastography Analysis monitor with description

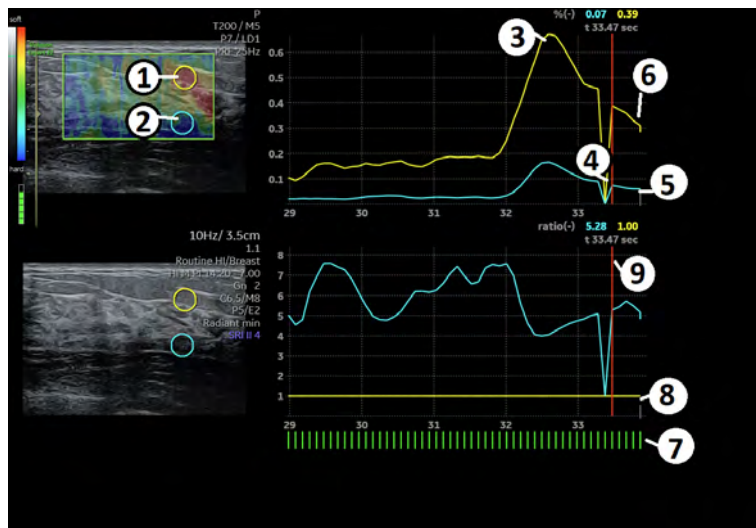

Figure 6-19 Elastography Analysis monitor display: description

- 1 Reference ROI
- 2 Lesion
- 3 Harder compression
- 4 Lower compression
- 5 Strain plot
- 6 Ratio plot
- 7 Frame indicator lines: green lines indicate frames with color in the Elastography image, red lines indicate invalid frames without color.
- 8 Reference ROI is set to 1
- 9 Lesion is 5.28 times as rigid as the Reference ROI

Elastography Analysis monitor display: example



Figure 6-20 Elastography Analysis monitor display: example

In both the Elastogram (top left) and the B-mode image (bottom left) a small dark lesion is visible. The reference ROI is placed in the fatty breast tissue (top yellow circle), the ROI 2 is placed in the lesion (lower blue circle). In the strain plot (top right) the strain of the reference is shown by the higher yellow line. Higher peaks of both lines are caused by harder compression. The lower right plot depicts the strain ratio of both ROIs. The reference is set to a straight yellow line with the value of 1, the strain ratio of the lesion is represented by the blue plot. In the example, the ratio between breast tissue and the lesion is always close to 5.3.

6.3.1.2 Shearwave Elastography

Note *Shear Elasto is an option and probe and application dependent. Shear Elasto is not available in all countries.*



Do not use Shear Elasto in case of pregnancy. Confirm that the patient is not pregnant, before using Shear Elasto.



Shear Elasto is not intended for Obstetrical exams.



Use Shear Wave Elastography as a complement to other techniques when making a diagnostic decision.

Shear wave elastography on the Voluson™ Signature 18 / Voluson™ Signature 20 system is an ultrasound imaging mode in which shear waves are generated in-vivo acoustically via the imaging ultrasound transducer. The motion of the shear waves is then tracked using ultrasound to determine their velocity of propagation, which is a quantifiable indicator of the mechanical properties of the tissue through which it traveled.

The steps associated with performing this analysis on the Voluson™ Signature 18 / Voluson™ Signature 20 system include:

1. Correctly placing a user-specific region of interest (ROI) over the anatomy of interest.
2. The user activates the shear wave analysis mode where the shear wave generation and tracking occurs.
3. After acquiring the data, the user either stores the image or analyzes it via measurement tools which can produce shear wave velocity or stiffness statistics of areas within the ROI.

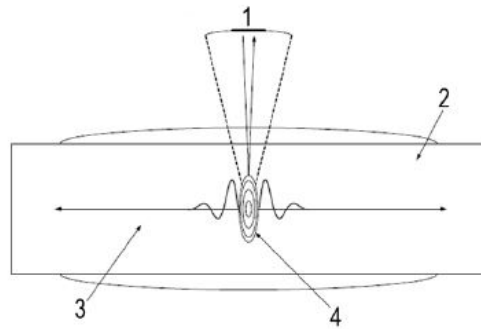

Figure 6-21 Shear Elasto Probe Characteristics

1	Excitation and imaging transducer
2	Tissue
3	Propagating Shear Wave
4	Focus

Shearwave Elastography

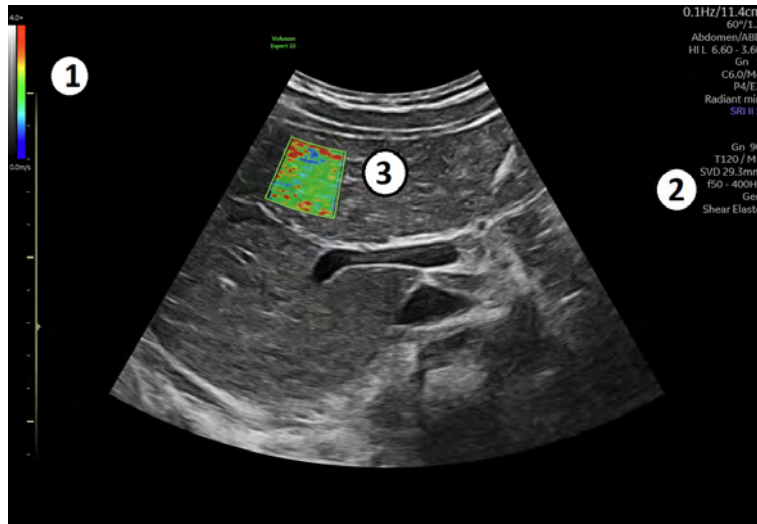

Figure 6-22 Shear Elasto run mode (example)

1	Shear Elasto map and scale information
2	Image Info
3	Shear Elasto ROI

Shear Elasto is activated by pressing **Shear Elasto** in 2D mode. As soon as **Shear Elasto** is pressed, the pre mode menu including the message "Tissue inhomogeneities and other factors may bias shear wave measurements" appears for 3sec:



It is possible to change the position and size of the ROI box with the trackball. When **Start** is pressed, Shear Elasto mode starts and color information is displayed. If the MI is less than 1.1, a yellow warning triangle and following message appears until the MI reaches 1.1: “With the current settings the shear-wave image is not suitable for diagnosis.”

Note *The MI can be enlarged by increasing **AO** to 100%, reduce box size or turning **Off HI** in B-mode, increasing the frequency in B-mode or by decreasing depth.*

Note *The displayed MI is not necessarily related to Shear Elasto.*

Note *The frame rate (if pulse inversion is active) ranges from 0,1 Hz- 1 Hz.*

Note *The lower edge of the ROI box is limited to max. 6cm in depth.*

When Shear Elasto read mode is active, and **Freeze** is pressed, Shear Elasto pre mode is activated again.

Image Info

Within the Image Info following parameters are displayed:

- Shear Elasto Gain
- Transparency/Map
- SVD (Sample Velocity Depth)
- Vibration Frequency Range
- Penetration depth
- Application mode: Shear Elasto state

Shear Elasto menu

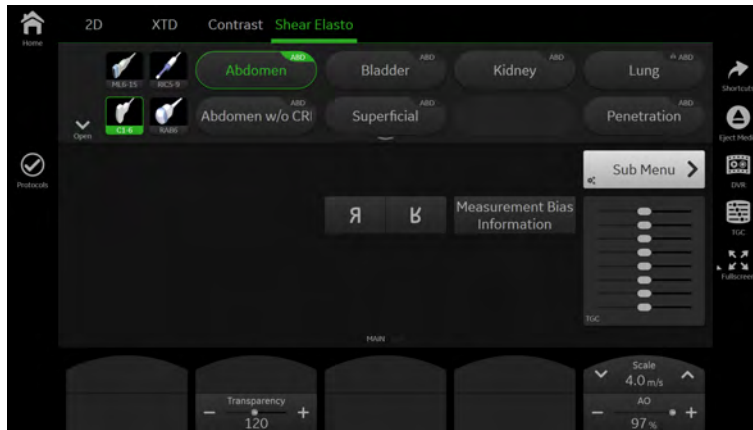

Figure 6-23 Shear Elasto menu (example)

As most of the controls are the same as in Elastography Mode, only the Shear Elasto specific controls are described here:

- Shear Elasto** Activates **Shear Elasto**.
- Measurement Bias Information** Displays the **Measurement Bias Information** dialog and precision percentage at different spatial resolutions (Bias/ Precision vs Object Size, in millimeters) and at incremental depths (Bias/Precision vs Depth, in centimeters) for each Shear Elasto probe.
- Shear Elasto Map** Displays the desired **Shear Elasto Map**.

Shear Elasto Measurements

Shear Elasto is a measurement used to quantify stiffness: Shear wave imaging measures the velocity of shear waves generated by acoustic radiation force impulse in tissue. Velocity or stiffness can be used to quantify the local tissue elasticity. The higher the velocity, the stiffer the tissue.

Note *Acoustic radiation force is generated by a transfer of momentum from an acoustic wave to the medium through which it is propagating, caused by absorption and scattering in soft tissue. Impulsive application of focused acoustic beams in tissue can generate shear waves which propagate away from the focal region of the beam.*

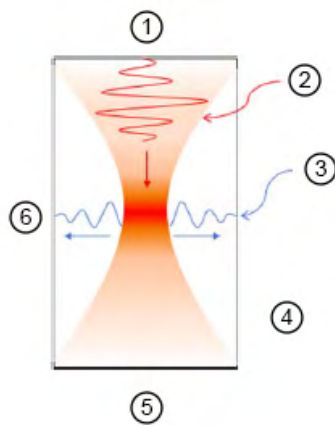

1	Transducer
2	Acoustic wave
3	Shear wave
4	Track generated shear waves

5	Apply high-intensity ultrasonic pulse to push on tissue
6	axial



Tissue inhomogeneities and other factors may bias shear wave measurements.



Excessive manual compression of the underlying tissue with the probe can lead to biased Shear Elasto measurements.

The measurement location must be in the center-region of the shear wave ROI and a minimum distance between measurement area and ROI-borders of 4mm is required, as displayed in the following figure:

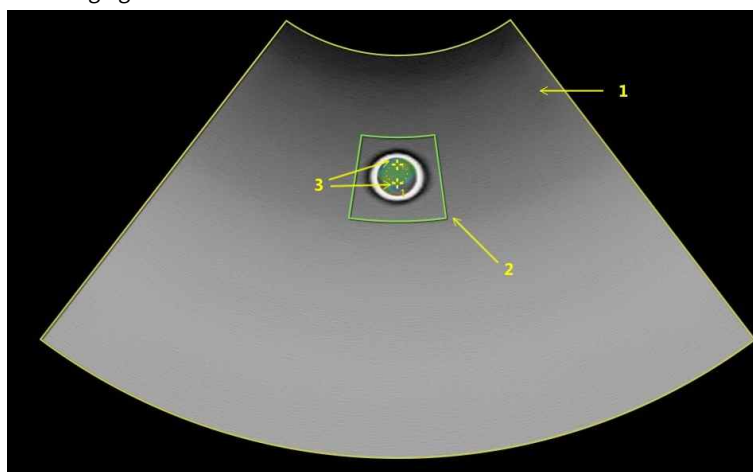

1	B-image
2	Shear Elasto ROI
3	Shear Elasto measurement

The result of the measurements is displayed in the **Worksheet** and in the **Report**.

Measurement Information

Shear Elasto velocity measurement and accuracy:

- unit: m/s
- useful range: Shear Elasto ROI with minimum distance of 4mm from ROI border
- accuracy: $\pm 15\%$ or 0.5 m/s, whichever is greater over the range of depths for which measurements can be made, limited by Shear Elasto penetration
- limitations or conditions: SD (standard deviation) less than or equal to 5% for multiple repeated measurements over the range of depths for which measurements can be made, limited by shear wave penetration.



The value for shear wave speed is a relative indice intended only for the purpose of comparison with other measurements performed using the Voluson™ Signature 18 / Voluson™ Signature 20 system. Absolute values for these measurements may vary among different measurement devices.

Measurement Bias Information

The Measurement Bias Information table displays the bias and precision percentage at different spatial resolutions (Bias/ Precision vs Object Size, in millimeters) and at incremental depths (Bias/ Precision vs Depth, in centimeters) for each Shear Elasto probe.



Using Shear Elasto

The bias corrected value of a measurement can be calculated with the following equation:

$$m_{res} = \frac{m_i}{(B + 1)}$$

Where m_i is a Shear Elasto measurement on the console, B is the bias value from the bias table and m_{res} is the final, bias corrected value.

There are three Shear Elasto states:

- Pre Shear Elasto acquisition: Pre Shear Elasto acquisition is an intermediate mode between B-mode and shear wave acquisition. During pre-mode, the previous B-mode imaging mode is still active.
- Shear Elasto acquisition: Pressing **Start** initiates SW acquisition.
- Post-Shear Elasto acquisition (**Freeze**): The system displays the acquired SW image and background B-mode image. It is possible to cycle through the acquired frames, perform measurements and annotate the image.

SW images can be stored in both raw data and DICOM format.

1. Press **Shear Elasto** to activate Shear Elasto.
2. Position and adjust the Shear Elasto ROI with the trackball.

Note *The measurement location must be in the center-region of the shear wave ROI and a minimum distance between measurement area and ROI-borders of 4mm is required.*

3. Press **Start** to commence the process.

Scanning Hints

You may find the following recommendations helpful when performing a Shear Elasto scan:

- Use a smaller ROI for faster Frame Rates.
- Suspend Patient breathing in mid-breath during the scan.
- Position the ROI between 2-5cm deep for an optimal Shear Elasto scan.
- Only compress slightly, if necessary (compression changes the elastic tissue properties).

To increase frame rate:

- Reduce ROI width (size)

- Turn Off HI in B-mode, if pulse inversion is active
- Increase frequency in B-mode
- Decreasing depth

To reduce artefacts:

- Minimize motion during acquisition
- Ensure there are no vessels within the ROI or near the left or right edge of the ROI. It is advisable to avoid rib shadows whenever possible.

6.3.2 Contrast

This option is only available with specific probes and applications.



Caution

- Cavitation may occur due to interactions between the ultrasonic waves and the contrast medium. Always perform examination using the ALARA (As Low As Reasonably Achievable) principle. The acoustic power can be adjusted by operating the **Acoustic Output** button on the user interface.
- Stop the examination and perform appropriate treatment, if there is any abnormality with the patient during use of the contrast medium.

Remark

- **Handle the contrast medium as described in the Instructions for Use supplied with the contrast medium.**
- **Check the side effects of the contrast medium used with the manufacturer of the contrast medium.**
- **GE ULTRASOUND KOREA, LTD. is not liable for any damage or injury resulting from improper use of contrast media.**

Injected contrast agents re-emit incident acoustic energy at a harmonic frequency much more efficiently than the surrounding tissue. Blood containing the contrast agent stands out brightly against a dark background of normal tissue. Possible clinical uses are to detect and characterize tumors of the liver.

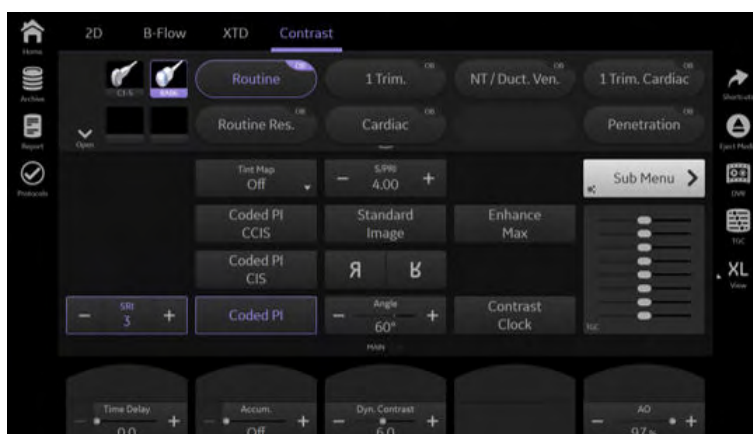

Figure 6-24 Contrast Mode (example)

Controls

Main Menu / Sub Menu	Opens the Main / Sub Menu .
Coded PI	Contrast Transmitter Mode: Coded PI
Coded PI / CIS	CIS (Contrast Imaging Simultaneous). Simultaneous display of the 2D image and the Contrast Image in a dual format left/right.

Coded PI / CCIS	2CCIS (Colored Contrast Imaging Simultaneous) Simultaneous display of the 2D image and the Contrast Image on a single format.
Standard Image	Contrast Transmitter Mode: Standard Image (2D Image)
SRI	Speckle Reduction Imaging (SRI) is an adaptive algorithm to reduce the unwanted effects of speckle in the ultrasound image. Image speckle usually appears as a grainy texture in otherwise uniform areas of tissue. Its appearance is related to image system characteristics, rather than tissue characteristics, so that changes in system settings, such as probe type, frequency, depth, and others, can change the appearance of the speckle. Too much speckle can impair image quality and make it difficult to see the desired detail in the image. Likewise, too much filtering of speckle can mask or obscure desired image detail. Extra care must be taken to select the optimal SRI level. SRI is available in B-Mode imaging and may be used with any transducer or clinical application when image speckle appears to interfere with the desired image detail.
Contrast Clock	Activate two timers shown on screen. Timer 1 counts the time of the contrast image in run mode. When an image freezes the timer stops counting and continues as soon as run mode is activated again. Timer 2 counts the time of the whole contrast examination.
2D/Gain	B-Mode Gain and Contrast Gain are independent from each other. B-Mode Gain is adjustable with the 2D Gain joycoder (only available when CCIS and CIS are selected), Contrast Gain with the 2D encoder.
Time Delay	Time Delay scans images at set intervals, delaying imaging according to the time delay specified.
Enhance Max	Sets the acoustic output to its maximum setting (100%).
TGC Sliders	The time gain compensation (TGC) curve graphically corresponds to the time gain compensation that is applied by the system. Tap onto the TGC button to open the TGC menu. Adjust the sliders as desired or press Reset to set them all back to middle position. Show Image displays the current live image (single view only).
Cine Speed	Regulates the replay speed of the cine.
Angle	Image Angle selects a part of interest of the 2D image. The advantage of the decreased field of view is an increased 2D frame rate due to the smaller sector width
Accumulation	Accumulation detects the maximum signal and holds it for the level specified.
Dyn. Contrast	Dynamic Contrast controls how echo intensities are converted to shades of gray, thereby increasing the adjustable range of contrast.
Acoustic Output	Adjusts the Acoustic Output .
Tint Map	Select the desired Tint Map .
Gray Map	The Gray Map determines the displayed brightness of an echo in relationship to its amplitude. Depending on individual requirements a “harder” or “softer” image can be obtained with this function and can be adjusted in freeze and in scan mode (post-processing).
Line Density	Line Density optimizes B-Mode frame rate or spatial resolution for the best possible image. It allows to make a trade-off between image resolution and frame rate.
Persistence	Persistence is a frame averaging function that allows elimination of image speckle from 2D images. With a higher persistence setting more frames are averaged.
Enhance	With the Enhance function the echo information is digitally processed such that certain existing information becomes easily visible for the eye (e.g., adjacent media layers). Due to the Enhance function a finer, sharper impression of the image is produced.
CCIS Map	Select the desired map.
S/PRI	Sensitivity PRI is used to adjust the sensitivity of the Contrast Agent. By increasing the sensitivity, you lower the frame rate; by decreasing the sensitivity, you raise the frame rate.
Balance	Decide whether to display a gray value or a colorized contrast value. (Only available in CCIS mode.)

Threshold

This function is only available in Frozen state or after pressing Freeze. It eliminates small color noise or motion artifact signals in the color image. It is similar to the Gain control in Scan Mode.



The Lt/Rt plane orientation button toggles the plane orientation.

Using Contrast Mode

1. Press **2D** on the touch panel to start B-Mode.
2. Press **Contrast** on the touch panel to start Contrast Mode.
3. The main **Contrast** menu appears on the touch panel.

6.3.3 Anatomical M-Mode (AMM)

The AMM imaging displays a distance/time plot from a cursor line, which is independent from the axial plane and positioned on the B-Mode image. Basically, each B-Image frame leads to one AMM-line and therefore a high B-image frame rate is necessary for a practicable AMM-image time resolution. Because the AMM Image is derived from a B-Image sequence it is also possible to do AMM-imaging on a frozen Cine Clip. Anatomical M-Mode gives you the ability to manipulate the cursor at different angles and positions. The AMM-image is calculated and displayed in real time when changing the AMM cursor position.

Note *When AMM pre-mode is entered, the last used display format is activated. If the 2D user program is changed, the display format saved in the user program is activated.*

**Using Anatomical M-Mode**

1. Select M-Mode.
2. Press the **AMM** button on the touch panel.
3. Adjust the AMM-cursor in the 2D single image.
4. Press **2D/M run** (left or right trackball button) to start AMM.
5. Press the top trackball button to toggle between position and rotation of the AMM cursor (**pos / rot.**).
6. Adjust or rotate the cursor accordingly.
7. Press the small trackball buttons to select the different cursor lines **AMM1** or **AMM2**.
8. Press **Freeze**.

Note *AMM can also be used with previously acquired and stored 2D cine sequences. Reload a 2D Cine and then switch on **AMM**.*

AMM Main and Sub Menu

General M-Mode touch panel buttons are described in 'M-Mode' on page 6-15.

AMM rot AMM rotation

Note *The AMM angle is determined by the virtual MM cursor line and the AMM cursor line. At 0° both lines have the same position. The maximum rotation is 180°. The max. CW/CCW rotation angle is limited (max. horizontal position on the screen), so the AMM-cursor is mirrored when it is not top/bottom oriented. During the angle rotation the image is updated in real time.*

Trackball Controls

Change	Toggles between pos and rot
pos	If activated, the position of the current AMM cursor can be changed.
rot	If activated, the position of the current AMM cursor can be rotated.
2D / M run	Updates the 2D image (only available in Dual and Quad format).
AMM x	Toggles between AMM x .
Image / Cine	Switches between image and cine controls. If Image is active, it is possible to navigate through the Cine with the trackball.

Cine gaps

If a data-interruption occurs during anatomical motion mode the cine gap is indicated by blue lines at the top and bottom in the AMM-image. If the cine gap occurs for a sufficiently long time also this  icon is displayed within the marked gap. It is possible to perform measurements across the cine gap.

6.3.4 Continuous Wave Doppler (CW-Doppler)

CW Doppler imaging includes a spectral analysis which describes the Doppler shift signal from the moving reflectors within the CW cursor line. The spectral display scrolls from left to right and depicts the spectral distribution of the components of the Doppler shift frequency over time. Frequency or velocity values appear on the vertical axis and time along the horizontal axis. Component amplitudes appear as shades of gray. The brighter the shade, the higher the amplitude.

The Doppler display can be used alone, but it is normally used with a 2D image. The 2D image contains a CW Doppler cursor that defines the location of the Doppler ultrasound beam relative to the 2D image display.

The angle correction cursor can be aligned with the direction of flow within the vessel to determine the Doppler angle. The system uses the Doppler angle to calibrate the Doppler velocity display. When the Doppler frequency display is used, the frequency display is not calibrated to account for the Doppler angle.

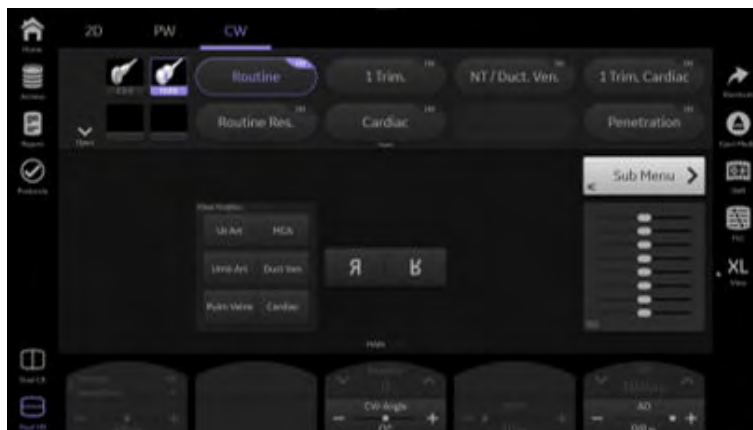

Figure 6-25 CW-Mode (example)

Controls

RT Trace	Real Time Trace on/off. When RT Trace is on, the spectral envelope curve, the TMean curve and the corresponding measurement results are displayed.
Sensitivity	Adjusts the sensitivity of the RT Trace .
Sweep Speed	Changes the speed at which the timeline is swept.
Invert	This function inverts the spectrum display in relation to the direction of flow. The displayed spectrum is inverted around the baseline. The velocity or frequency scale changes accordingly. Use Invert when necessary to change the spectral display orientation. It is possible in both freeze and scan mode.
Baseline	Baseline similar to the PW Doppler baseline shift shifts the baseline to enlarge the velocity range in one direction.
CW Angle	Enables the correction of the Doppler velocity scale by defining the angle between the Doppler beam and the investigated blood vessel or blood flow.
WMF	The Wall motion filter eliminates vessel wall motion noise that is low in velocity but high in intensity. Use a wall filter that is high enough to remove motion artifacts, but that is sensitive enough to display low velocity flows in small vessels. Available settings: low1, low2, mid1, mid2, high1, high2 and max.
Acoustic Output	Adjusts the Acoustic Output .
PRF	The Pulse Repetition Frequency (PRF) has direct influence on the velocity range. The higher the Pulse Repetition Frequency the lower the velocity range. As the display scale increases, the maximum Doppler shift information that can be displayed without aliasing also increases. Aliasing is where the blood velocity exceeds the maximum measurable velocity, causing the displayed flow within the vessel to portray flow in the wrong direction. The disadvantage of using a higher PRF is a loss of sensitivity to low flow velocities.
Volume	Adjusts the Volume .
Steering	Beam steering creates ultrasound beams that are not perpendicular to the surface of the probe but have an angle. This allows getting CW Doppler signals from flows that run parallel to the probe's surface.
Steer Flip	Press Steer Flip to flip the PW cursor position round the vertical axis. The steering angle value changes from plus to minus and vice versa.
Main / Sub Menu	Opens the Main / Sub Menu .

Flow Profiles

Select between the following **Flow Profiles**:

- Ut Art
- MCA
- Umb Art
- Duct Ven
- Pulm Veins
- Cardiac

Depending on the System Setup settings the following values are set:

- **PRF**
- **WMF**
- **Baseline**
- **Sweep Speed**

Only one button can be active at the same time. Pressing the button again deactivates it. Use **Flow Profiles** for optimizing vessel flow representation scanning.

Note *Flow Profiles are only available for OB probe applications.*

Note *It is possible to reorder the measurement buttons within the box as desired. Press onto the configuration symbol to select between Configuration (enables the touch menu **configuration** for the measurement box) and Back to Default (restores the factory configuration).*

SRI

Enables/disables **SRI** on the motion image.

Cine Speed

Regulates the replay speed of the cine.

Gray Map

The **Gray Map** determines the displayed brightness of an echo in relationship to its amplitude. Depending on individual requirements a “harder” or “softer” image can be obtained with this function and can be adjusted in freeze and in scan mode (post-processing).

Tint Map

Displays the tint map selections on the monitor.

Units

Select between 3 different scale units (**kHz, cm/s, m/s**).

Dynamic Contrast

Enables control over the contrast of the CW Doppler spectrum. When dynamic is raised, the spectrum image becomes softer and some low-level background noise may appear.

Trackball Controls

CW-pos

Changes the position of the CW cursor (horizontal movement). horizontal movement: position of the CW Cursor on the 2D image on screen or the position of the angle correction (vertical movement).

Image / Cine

Changes between **Image** and **Cine**.

Cine

Scrolling of B images.

Loop

Scrolling of the CW spectrum (only possible if more spectrum lines are saved as fit into the CW window).

Change

Toggles between **Cine** and **Loop**.

Play / Stop

Starts or stops the CW cine spectrum playback.

Edit Cine

Opens the **Edit** trackball mode.

Set Start / End

Sets the start or end of a cine playback.

Update

starts the CW acquisition or toggles between CW and B image

Using CW-Doppler

1. Press **2D** on the user interface to start 2D-Mode.

2. Press **PW** on the user interface to start PW-Mode.
3. Press **CW** on the touch panel to start CW-Doppler Mode.
4. The **CW pre** menu appears on the touch panel.

Hint *To change CW Gain rotate the **PW**-encoder (run and read mode).*

Note *The availability of some functions or features depends on the probe and ultrasound system used.*

Cine gaps

If a data-interruption occurs during motion mode the cine gap is indicated by blue lines at the top and bottom in the CW-image. If the cine gap occurs for a sufficiently long time also this  icon is displayed within the marked gap. It is possible to perform measurements across the cine gap.

This page was intentionally left blank.

Chapter 7

Image management

<i>SonoLyst</i>	7-2
<i>Scan Assistant</i>	7-7
<i>Image Annotation</i>	7-11
<i>Cine Mode</i>	7-18

7.1 SonoLyst



Caution

SonoLystIR, SonoLystX & SonoLystlive should be used during second trimester (18-24 weeks) ultrasound scans of normal singleton fetuses.



Caution

SonoLystIR, SonoLystX should be used during first trimester (11-14 weeks) ultrasound scans of normal singleton fetuses

Note *SonoLyst is an option on Signature 18, It's standard on Signature 20.*

All SonoLyst features are workflow supporting features and are all based on Deep Learning technology:

- SonoLystIR – analyzes a frozen ultrasound image and determines whether the image contains one of the pre-defined standard views or not (see list of pre-defined standard views below). SonoLystIR can only be used in conjunction with the Scan Assistant. It adds the capability to the Scan Assistant to select Scan Assistant List items linked with one of the pre-defined standard views.
- SonoLystX – works in conjunction with SonoLystIR described above. In addition, if a pre-defined standard view is found by SonoLystIR, the fulfillment of criteria is assessed - for example the presence of certain anatomical structures in this plane. The assessment of this analysis is displayed for the user (pre-defined standard view and depending criteria).
- SonoLystlive – works similar to SonoLystIR without Scan Assistant and can be enabled in the System Setup. This means SonoLystlive performs an assessment with respect to pre-defined standard views. The assessed standard view is displayed for the user in the live and in the frozen image. Additionally an indicator is shown which reflects the quality of the detected view based on detected criteria (see SonoLystX) in the assessed standard view. SonoLystlive is enabled when an OB exam is started and available in live mode, freeze and in reload.

The output image of the SonoLystlive feature is shown below as an example, displaying the detected 4 Chamber Heart view and the green status indicator:



As SonoLystIR and SonoLystX are deeply integrated in the Scan Assistant workflow, please refer to 'Scan Assistant' on page 7-7 for more details about the usage and setup.

All SonoLyst features use the following predefined standard views and depending criteria for the 2nd Trimester :

Pre-defined standard view	Criteria
Transventricular Plane	Magnification Brain symmetry Midline falx Lateral cerebral ventricles Choroid Plexus Cavum septum pellucidum No Cerebellum
Transthalamic Plane	Magnification Brain symmetry Midline falx Thalamus Cavum septum pellucidum No Cerebellum
Transcerebellar Plane	Magnification Brain symmetry Midline falx Cavum septum pellucidum Cerebellum Cisterna Magna
Profile	Magnification Nasal tip Forehead bone visible
Orbits	Magnification Both orbits visible Symmetrical orbits
Nose/Lips	Magnification Nasal tip Nostrils Upper lip
4CH/Thorax	Magnification 4 Chambers visible Ventricular Septum Valves visible
LVOT	Continuity Ventricular Septum Magnification
RVOT	Vessel Bifurcation Magnification
3VV/3VT	3 Vessels Magnification
Abdomen (AC)	Magnification Stomach Umbilical vein Rib visible Circular/Shape No Kidney
Abdomen - Cord Insertion	Magnification Cord visible

Pre-defined standard view	Criteria
Transverse Kidneys	Magnification Both kidneys visible
Bladder	Magnification Bladder visible
Umbilical Cord (3VC)	Magnification Bladder visible
Femur	Magnification Angle of insonation Clear Diaphysis
Foot	Magnification Full foot visible
Hand	Magnification Clear hand visible Hand palmar view
TA Cervix	Magnification Endocervical Canal Internal Os External Os
Spine Sacrum	Lumbar - alignment Lumbar - Skin line Magnification
Spine Lumbar	Lumbar - alignment Lumbar - Skin line Magnification
Spine Thoracic	Thoracic - alignment Thoracic - Skin line Magnification
Spine Cervical	Cervical - alignment Cervical - Skin line Magnification
Upper Arm	Magnification Upper Arm visible
Forearm	Magnification Forearm visible
Upper Leg	Magnification Upper Leg visible
Lower Leg	Magnification Lower Leg visible
Sagittal Foot	Magnification Sagittal Foot visible

SonoLystlive

Note *SonoLystlive is an option and only available with an OB exam.*

SonoLystlive can be invoked from/started with:

- PID

- Protocols touch menu
- C-Key (start of SonoLystlive 2nd Trimester only)
- Trackball

SonoLystlive can be paused with:

- **Pause** on the touch menu
- Trackball
- C-button

If deactivated in the system setup and a detected view contains measurements, no auto-capture is executed. It is necessary to freeze manually, then the first configured measurement is started. As long as auto-captured images are not confirmed/accepted by the user either on the touchpanel or via trackball, a warning symbol and informational text are displayed.

Before an exam including SonoLystlive items is closed, a dialog appears asking for confirmation. Select between:

- **Continue Exam** (Closes the dialog, the exam is still ongoing.)
- **Review Images** (Opens the exam review to review/delete images as desired.)
- **Accept & End Exam** (Closes the dialog and the exam. The warning symbol disappears as all images are confirmed/accepted.)

Note If a left/right view is detected, **Left/Right/Both** is displayed instead of **Accept**.



Figure 7-1 SonoLystlive monitor display (example)

If configured the last captured image is displayed on the monitor together with the detected view name. A message appears when an image is captured and the following symbols (detected view status) are displayed:

Indicator	Description
	no view detected (0)
	view detected - middling view (>0 - <0.5)
	view detected - good view (≥ 0.5)

In the Flexible Display area all selected views for detection are displayed. Views deactivated in the system setup are disabled. The view icon contains a capture counter. As soon as the capture count is reached, the counter gets a checkmark and the view icon is dimmed. Furthermore in **Freeze** mode a SonoLystX section is visible displaying the view (if detected) depending on SonoLystX criteria.

If the SonoLyst view in the Flexible Display area is hidden, the progress of SonoLyst*live* is displayed instead of the common icon. It is possible to display it again by pressing onto the progress symbol. The left number is the number of images which reached the capture count, the right number is the number of possible views.

Note *If more than one Spine or Extremity view is detected, all of the views are displayed next to the hexagon.*

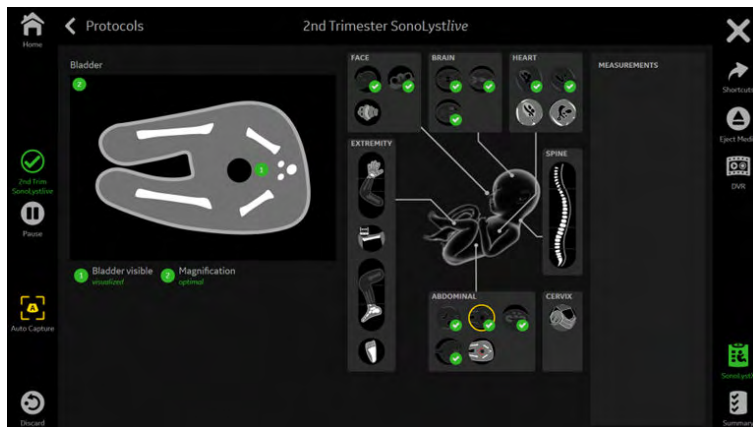

Figure 7-2 SonoLystlive Protocol touch menu (example)

The touch menu is opened by pressing **2nd Trimester SonoLystlive**. It contains SonoLystX (can be switched on/off by selecting the corresponding button) and measurements (if configured).

Summary opens the SonoLyst*live* 2nd Trimester worksheet. A green checkmark indicates that the capture count is reached. If the count is not reached or no view stored, no checkmark appears. Detailed criteria for available views are displayed.

With **Auto Capture** it is possible to switch between the levels:

- green: only good views are captured
- yellow: good views and middle views are captured
- gray: no **Auto Capture** active; manual action required

Pause / Continue switches between live mode and pause state. When SonoLyst*live* is paused, a blue infobox is displayed on the main screen and within the **Protocols** menu on the touch panel.

Trackball buttons:

SonoLystlive / Pause	Toggles between SonoLyst <i>live</i> and Pause .
Discard	Deletes the image from the clipboard.
Accept	Accepts the image.
Left/Right/Both	A left/right view is detected. Accepts the image by selecting the correct side/both sides and adds it to the configured annotation. The corresponding icon in the Flexible Display area increases the capture count.
Measure	Saves and reloads the image. The first measurement of the next incomplete measurement is started automatically. It is possible to perform all configured measurements for the auto-captured view.

Note *Only available when **Auto capture views with measurement** is selected in the system setup.*

7.2 Scan Assistant

The Scan Assistant is a tool with guidelines for sonographers. It offers specific factory checklists containing the anatomical structures or organs to be examined in certain examinations and so prevents from missing important items. It is possible to customize these checklists and also to set up new lists. Additionally the Scan Assistant can be used to activate a specific measurement for an exam item as well as annotate, save or send the image for documentation purposes.







Following sections/items are displayed:

- list name
- progress viewer / Pause

Note *If during an exam the Scan Assistant menu is hidden, the symbol is replaced by a progress symbol, which shows the progress of the active Scan Assistant list.*

- selected group (if available)
- selected item
- description area
- measurement result area
- Fetal Anatomy (OB) / Findings (GYN) area
- SonoLystX area (only visible when a SonoLystX item was found and SonoLystX view is activated on the touch panel)

Following icons are displayed:

1.  is displayed at the measurement header when a measurement is required.
2.  is displayed at the description header when the current item is an optional item.
3.  is displayed at the **Fetal Anatomy (OB) / Findings (GYN)** header when a fetal anatomy item (OB) / finding (GYN) is required.
4.  is displayed if an SonoLyst linked item is active.

Activating the Scan Assistant

1. Press the **Patient** button on the touch panel.

2. Select a checklist from the Scan Assistant drop down list of the Patient Information Dialog.
3. Start the exam.

Editing the Scan Assistant

1. Press **System Setup** on the touch panel.
2. Open the **Connectivity** page and go to the **Button Configuration** tab.
3. Select a P-Button and check the box **Confirm Scan Assistant item with Px.**
4. Open the **General** page and open the **Scan Assistant** tab. Edit the settings as preferred.
5. Press **Save & Exit.**

For more information see ' Scan Assistant ' on page 11-11.

Using the Scan Assistant

1. Start the exam by scanning the first item of the first category.
2. When the item is scanned, freeze the image and press the P-Button configured for confirming.

Note *It is also possible to check/uncheck an item manually by tapping at the check area (circle).*

3. The item is checked and the next item turns green.
4. Scan all items of the category and move to the next category. If the items cannot be scanned in the predefined order, use the arrow keys on the keyboard or on the touch panel to change between items and/or categories.
5. Press **End Exam** to finish. A summary of the Scan Assistant is displayed on the screen showing all (not) examined categories and items.

Scan Assistant Menu

If an exam in the Scan Assistant list is active, it is possible to open the Scan Assistant menu by pressing the corresponding button located in the control area or by pressing **Freeze** (depends on the system setup configuration).

Note *When an exam is reloaded from the archive, no Scan Assistant screen is displayed.*

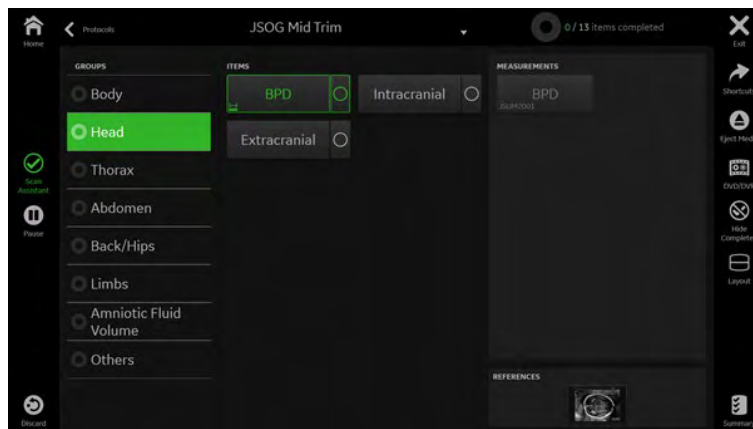

Figure 7-3 Scan Assistant without SonoLyst (example)

When a new item is selected/confirmed which includes a mode change or a wrong probe connected, the system displays a message informing the user about the issue (e.g. to select a certain mode manually or to connect the correct probe,...).

Note *The progress bar shows the progress of items.*

Note *Optional items are labeled "optional" and differ in appearance.*

Controls

List	Select the desired list.
Groups	Select the desired group.
Items	Select the desired item.
Protocols	Select the < arrow to go back to the Protocols page.
Scrollbar	If more than 8 groups or 14 items are available a scrollbar is displayed.
Measurements	All measurements available for the selected item are displayed. It is also possible to select the desired cine by rotating the control or by using the trackball (if Cine is active). When Calc is active, Set on the trackball sets the measurement to the selected point while Magnifier activates the magnifier. Cancel stops the active measurement.
Fetal Anatomy (OB) / Findings (GYN)	All Fetal Anatomy (OB) / Findings (GYN) items for the selected Scan Assistant item are displayed.
Reference area	All item depending references are displayed. The currently selected reference is highlighted in green. Tap at another reference image to switch the reference image at the screen menu.
Hide Completed	If on the completed items are hidden, otherwise (off) they are displayed. The active item is always visible.
Layout	Switch between vertical (off) and horizontal (on) scroll layout.
Pause	Pauses Scan Assistant during an exam. No selections are possible.
Fetus	Select the desired Fetus.
Summary	Opens the Scan Assistant worksheet summary page.

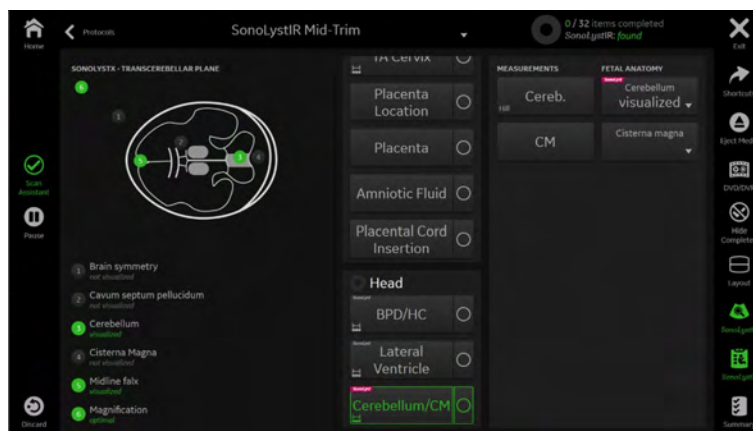

Figure 7-4 Scan Assistant with SonoLyst (example)

If an item is linked to a SonoLyst image and the system finds a depending plane, this item is displayed on the touch panel.

The items linked to SonoLyst are labeled accordingly with a badge (only available when the option is set). SonoLystX shows the corresponding pictogram and criteria.

It is also possible to switch the SonoLystIR image recognition algorithm on and off. When the image is zoomed in or out or another image is selected from the cine buffer, the SonoLyst algorithm is restarted (if switched on).

Instead of the group area all SonoLystIR view depending criteria are displayed. It is possible to set a criterion to found/not found manually by tapping onto the circle.

Starting/selecting Scan Assistant lists can also be done by pressing **Protocols** on the touch panel. Three different states are available:

1. No Scan Assistant or Assessment Tool is started: Select the desired tool or list and press **Start**. The menu closes automatically.

2. Already ongoing Scan Assistant list or Assessment Tool:
 - The ongoing Assessment tool list is paused. Press **Continue** to go on. Press **None** to deactivate the currently ongoing Scan Assistant list without losing data.
 - Select a Scan Assistant list and press **Start**. The menu closes automatically.
 - Press **Discard** to clear the currently selected list or tool. Confirm the clearing of data (**Yes**) or decline (**No**).
3. No exam started: A message appears together with the **Start Exam** button. Press the button to open the Patient Information Dialog.

The **Auto Capture** function for Scan Assistant depends on the system setup settings for SonoLystlive. If **Auto Capture** is enabled and a view of a Scan Assistant item is captured with SonoLystlive configured, it is possible to select between **Accept** (saves the image to the clipboard, the Scan Assistant item is checked automatically and configured annotations are inserted automatically) or **Discard** (the corresponding item is unchecked and deleted from the clipboard) on the trackball.

With **Auto Capture** it is possible to switch between the levels:

- green: only good views are captured
- yellow: good views and middle views are captured
- gray: no **Auto Capture** active; manual action required

7.3 Image Annotation

This function enables text writing onto the ultrasound image. Specific functions can be programmed in the System Setup. *For more information see 'Annotation' on page 11-8.*

Two independent text layers 1 and 2 are available to annotate the ultrasound image. The text layers are not dependent on display format and/or scanning modes.



Figure 7-5 Text/Annotation Touch Screen Menu (example)

Entering Annotation Mode

It is possible to enter Annotation mode via:

- **Abc**

The text cursor appears at a predefined position configurable in the system setup. When annotation mode is exited, the cursor position will be remembered and set again when the mode is reentered. The annotation touch screen menu appears as well as the on screen menu **Text** if configured in the system setup. The buttons **Text Layer 1**, **Text Layer 2** and **Text Layer 1+2** have the same function as on the touch menu.

Exiting Annotation Mode

Annotation Mode can be exited directly, indirectly or through timeout.

1. Direct exit: Press either **Abc** or **Exit**. The cursor disappears and the touch panel returns to its previous state.
2. Indirect exit: Any user action that takes over control of the trackball and/or cursor deactivates annotation mode (i.e. change of image mode)
3. Timeout exit: If a timeout is configured in the system setup, the mode is deactivated and the normal scan menu appears.

Annotation Area, Font and Color

The annotation area is the same area as the ultrasound image area.

The color for annotations is yellow for **Text Layer 1** and orange for **Text Layer 2**. These colors cannot be changed. To indicate that a particular annotation is active, the color turns to green. Once the annotation is fixed with **Set**, the color returns to yellow or orange.

7.3.1 Annotation Touch Panel

The touch panel has:

- a soft keyboard, a predefined list of annotations (labels) and an autocomplete section
- a text label library selection (popup window)
- 35 label buttons per page

- a default page on annotation mode activation (When a new exam is started always the current exam application and the first page is set as default. When the Probe preset application or the exam application is switched, the depending application and page are set.)
- three types of Auto text controls (single buttons with one text line, small list buttons with popup and small list buttons with toggle function with max. 4 text lines)
- text keys that can be configured to hold a small list of up to 4 annotations

Annotation Controls

Hard key Controls	
Abc	Annotation on/off
Clear	Text on selected Text Layer 1 , Text Layer 2 or Text Layer 1+2 can be deleted.
Exit	Closes Annotation.
Trackball Controls	
Trackball	Set text cursor or text position.
Set	Used to fix a text when there is active text.
Grab Word	Highlight function of a word
Word Delete	Delete the last entered word.
Touch Panel	
Abc Annotate	Opens the annotation menu.
Indicator	Opens the indicator menu.
Bodymark	Opens the bodymark menu.
Text Layer 1	Text Layer 1 is activated as active page and the layer is displayed on screen.
Text Layer 2	Text Layer 2 is activated as active page and the layer is displayed on screen.
Text Layer 1+2	Both layers are displayed on the screen.
Swap Keyboard	Change the soft keyboard position from bottom to top and vice versa.
Keyboard	Hides or opens the soft keyboard.
Library (folder icon)	Select the desired library/application from the popup window.
Page / Page selection	Select pages via tapping on the tab area or by swiping.
Hide Text	The whole text is hidden on the screen but not deleted.
Text Size	Adjust the font size via touch slider (availability: 20 - 60, default 35) or rotating the rotary control.
Auto text buttons	Different types of auto text buttons are available): <ul style="list-style-type: none"> • button with one text line • popup button with max. 4 text lines • toggle button with max. 4 text lines
Delete Last	Deletes the last entered text.
Grab Word	Slide the button to select (grab) a word.
Delete Grab	Press the button to delete the currently selected (grabbed) word.

Touch Panel	
Configure	<p>Opens the configuration mode for auto text buttons (sort, rename, add, delete). Auto text buttons are marked with a blue frame in configuration mode. It is possible to drag and drop them to the desired position or to another page.</p> <ul style="list-style-type: none"> ● Tap onto a page header to rename the page. ● Select an empty button to enter the desired text (max. 4 entries with 24 characters each per button) ● Tap onto an existing auto text button to rename it. ● Press the Delete symbol to delete the button. ● Press Clear Folder to select between: Clear all items to delete the whole library, Clear current page to delete only the currently visible page and Cancel to close the dialog without deleting. ● Press Save to store the changes or Save & Exit to save the changes and leave configuration mode.
Home	Resets the cursor to its default position on the screen.
Set Home	Press Set Home to define a new Home position.
Exit	Closes the annotation menu.

Annotation controls - other functionality

Home	This key resets the cursor to its default position on the screen. (Home position application specific (not selected) defines a global cursor position for all exams, Home position application specific (selected) for each specific exam.)
-------------	--

7.3.2 Text

Text can be entered by using only software keyboard. The software keyboard can be used to type freely on the screen. The text is visible on the display screen at the location of the text cursor as the user types.

1. Auto text preset via touch panel: Tap onto an auto text preset at the touch panel to enter the desired text. Multiple selections are possible.
2. Auto-complete: As soon as typing is started on the software keyboard, autocomplete suggestions are displayed on the autocomplete bar. Tap onto the desired suggestion to enter the text.

Editing text

Trackball and Set	<p>To select a word/text group the cursor must be placed upon the text group. If the cursor is placed upon the text group, the font color changes to green indicating that the text group can be selected. With Set the text will be selected.</p> <p>In fixed mode the text cursor can be positioned over a word of an existing comment and the word can be modified without pressing Set.</p> <p>Keys to start text editing: all character keys, backspace, space, return</p>
Grab Word	<p>Word grabbing with this button is only possible if the text cursor is positioned over a text group and text color has changed to green. If Grab Word is pressed, then the word nearest to the text cursor is highlighted. If the button is pressed sequentially, always the next entered word is highlighted.</p>

Deleting text

New exam	When a new exam is started all text annotations are deleted on Text Layer 1 and Text Layer 2 .
Unfreeze	When an image is unfrozen all text annotation is deleted on the active Text Layer 1 or Text Layer 2 . This depends on the presets in the system setup.
Means to delete text	<ul style="list-style-type: none">● Backspace (Software keyboard: deletes character by character or whole words when they are highlighted)● Word Delete (trackball)● Clear● Delete last (touch panel button)● Highlighted Text Replacement (Typing with the software keyboard deletes highlighted text and replaces it with the newly typed text.)

Annotated text remains if the probe or setting is changed. End Patient/Exam deletes the text annotation.

7.3.2.1 Text Cursor

The cursor can appear in three different states:

Fixed Mode: not flashing	In this state the cursor itself can be positioned to select a new text position or a current word or text group for editing. When text entering is started or an existing text is selected, state 2 (Active Mode) is activated and the cursor starts flashing
Active Mode: flashing	In this state the cursor and the text will be positioned together, the current green text hangs on the cursor. With Set the text entry is fixed, the text color changes and state 1 (Fixed Mode) is activated again.
Invisible Mode: hidden	If the text cursor is moved out of the annotation area into the onscreen area it is hidden and the system cursor appears in the onscreen area to operate/select the screen controls. If the system cursor is moved into the annotation area again the text cursor appears on the position where the system cursor passed the annotation boundary and the previous state 1 or 2 is selected again.

The text cursor is not visible on the screen when the system is not in annotation mode. The character modes **Insert** and **Overwrite** have different cursor widths.

7.3.2.2 Text Group

There is a group concept behind the entered text:

All entered words which are fixed with **Set** belong to one group. The beginning of a group is marked by manual placement of the cursor. Pressing **Return** brings the cursor down to the next line where typing can be continued. The multiple lines entered via **Return** form the same annotation group. The whole group of words can be moved with the trackball. When moving the text cursor over a fixed group (yellow font) the font color turns to green and the group can be activated for editing/positioning with **Set**.

Group Move/Word Wrapping

- If no blank is entered: automatically Group move is activated. If the group position reaches the left border no text entry is possible
- If a blank is entered: automatically Word Wrapping is activated and the next word separated by the blank is wrapped to the next line. When the bottom line is reached, word wrapping is not possible, only Group move can take place.

7.3.3 Printing Annotations

Annotations and indicator marks can be printed by using the usual print keys on the front panel. Annotations and arrow marks present on the screen appear on images stored to disk or sent to a DICOM device. The annotations cursor never appears on the saved / printed images.

Annotation mode remains active after an image is printed or saved to disk.

7.3.4 Indicators

By double pressing  or by selecting the indicator icon within the annotation menu on the touch panel, two independent types of indicators are available:

- arrow (big, mid or small)
- hand (big, mid or small)

Indicator menu

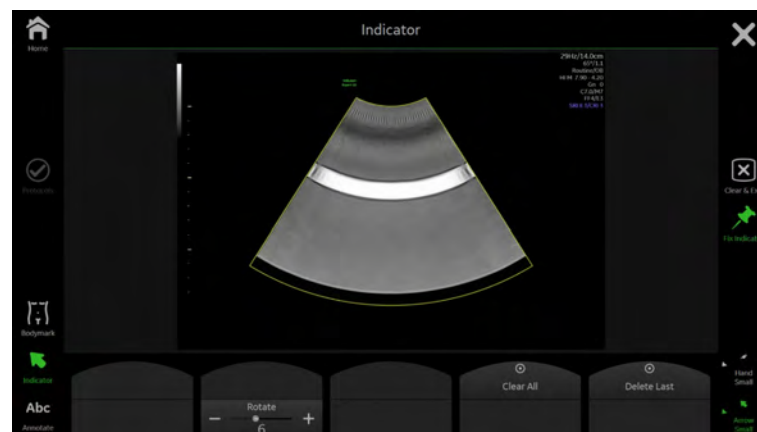

Figure 7-6 Indicator menu (example)

Setting an indicator

1. Switch on the indicator function. The last selected indicator appears in the middle of the annotation area.
2. Change the type of indicator (if wanted).
3. Position the indicator with the trackball or tap at the desired place on the touch panel.
4. Rotate the indicator (if wanted) with the rotation function of the trackball.
5. Store the indicator with the **Set** key or tap on the touch panel for the next indicator (if **Set Indicator** is enabled (green)).
6. To delete all fixed indicators press **Clear All** or **Clear** hardkey. Press **Delete Last** to delete the last entered indicator.
7. **Clear & Exit** clears all entered indicators and leaves the indicator menu.

Exiting Indicator Mode

Indicator Mode can be exited directly, indirectly or through timeout.

1. Direct exit: Press **Exit** to deactivate Indicator Mode.
2. Indirect exit: Any user action that takes over control of the trackball and/or cursor deactivates Indicator Mode

3. Timeout exit: If a timeout is configured in the system setup, the mode is deactivated and the normal scan menu appears.

7.3.5 Bodymark

For the documentation of the scan position on the patient, a selection of graphic body symbols (bodymarks) is available. A short bright line indicates the scan position. This line can be positioned freely on the bodymark symbol.

Press **ABC** and select the **Bodymark** icon to open the bodymark menu. A default bodymark is displayed automatically when **Bodymark** is activated.



Controls

Library (folder icon)	Opens the popup menu to change the bodymark application/library.
Bodymark symbol	Inserts the pressed symbol to the US area.
Exit	Closes the menu.
Clear & Exit	Closes the menu and deletes the inserted bodymark.
Configure	Enables the configuration mode to reorder the bodymark symbols.
Rotate	Rotates the probe orientation marker.
ABC, Indicator, Bodymark	Switch between the different annotation modes by selecting the desired tab.

Trackball

pos. Scan	Moves the orientation marker inside the bodymark symbol.
rot. Scan	Rotates the orientation marker.
pos. Symb.	Moves the bodymark symbol inside the US area.
Change	Switches between pos. and rot. Scan.
Set	Closes the bodymark menu.

Note *The scan plane identification is shown in scan mode and freeze mode.*

Screen Display

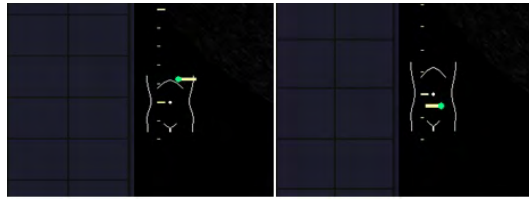

Figure 7-7 Screen Display

The probe mark has a green spot that indicates the orientation of the probe. The probe can be rotated by using the **Rotate** control.

The bodymark symbol appears in the left lower corner of the B-Image.

7.4 Cine Mode

While scanning a certain number of frames (2D images of the last examination sequence) are stored in the cine memory automatically. This is indicated by the green bar. By pressing the **Freeze** button or the defined **Px** button, the cine memory is stored as a sequence. This sequence can be reviewed in loop mode or image by image. After the cine clip is stored the cine memory is deleted. Move the trackball horizontally to display the 2D images of the stored sequence, one by one.

Cine Mode Monitor Display



Figure 7-8 Cine Run

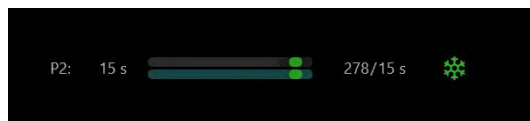

Figure 7-9 Cine Freeze

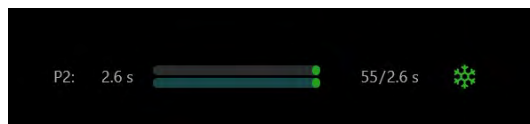

Figure 7-10 Edit Cine

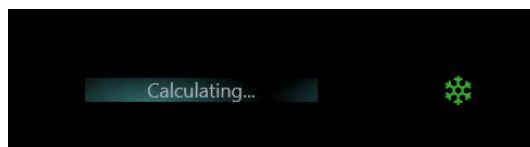



Figure 7-11 Save Cine

Px	Programmed Px button
xx s	Default clip length in seconds programmed under a Px button
upper bar	Save clip (corresponding to the activated Px button)
lower bar	Acquisition clip (original clip)
xx/yy s	Alphanumeric display of the currently captured cine length in frames (xx) and seconds (yy).
	Freeze (green) and Run (grey) icon
Cine image marker	Green marker on the upper/lower bar (only present in Freeze mode). The position corresponds to the image (clip frame) on the screen. The marker can be moved using the trackball. The marker is green as long it is inside the "save clip" section. Outside of the "save clip" section it turns red.
Calculating	Displayed during the Save process.

Remarks:

- The number of stored images depends on the number of scan lines, scan depth and magnification. In **Freeze** mode the length of the sequence is indicated on the status bar.
- Starting the Cine mode erases measuring marks and measuring displays.
- The Cine Function (operation and storage) is identical in 2D mode and CFM mode.

Cine Controls

Cine	Select image after image of the cine clip.
Edit Cine	Enables editing a cine.
Play / Stop	Starts/stops the cine clip.
update 2D	Updates the 2D image (only available in Dual and Quad format).
Full x / Dual	Toggles between Full x and Dual (only available in Dual format).
Set Start	Replaces the old start image with the newly selected one.
Set End	Replaces the old end image with the newly selected one.
Exit	Exits closes the Edit Cine mode.

Editing a clip

1. Press **Edit Cine** on the trackball to enter the edit mode.
2. Use the trackball to scroll through the images.
3. Press **Set Start** to define a new start image.
4. Press **Set End** to define a new end image.
5. **Exit** closes the edit mode.

Retrospective and Prospective cine mode

- Retrospective Cine: When the cine clip is saved in retrospective cine mode, all frames that have been captured will be saved when the [Freeze] key or the [Px] key are pressed. Then the cine clip will be saved. (time adjustable)
- Prospective Cine: When saving the cine clip in prospective cine mode, all frames will be saved beginning at the moment of activating the cine (time adjustable).

This page was intentionally left blank.

Chapter 8

3D and 4D Mode

<i>Visualization</i>	8-3
<i>General advice to obtain good rendered 3D/4D images</i>	8-7
<i>Initial Condition of different Probes</i>	8-8
<i>3D/4D Mode screen display</i>	8-10
<i>Volume Acquisition Modes</i>	8-13
<i>Volume Visualization Modes</i>	8-22
<i>Additional tools</i>	8-37

This chapter describes how to use 3D and 4D Mode, also referred to as Volume Mode.

The Volume Mode allows for scanning a tissue volume and subsequent analysis of sections of the volume in 3 dimensions. The liberal selection of sections within the volume and the simultaneous real-time 4D display of three orthogonal planes and a rendered 3D image represents a new dimension for e.g., the diagnosis of fetal abnormalities. The Volume Mode provides access to sections unachievable by the 2D scan technique. A parallel interface provides the possibility to save volume data on a hard disk drive for repeated analysis anytime.

Principle of Volume Acquisition

The acquisition of volume data sets is performed with special transducers designed for 3D/4D imaging. A volume data set consists of a series of 2D Images. The Volume acquisition is started using a 2D-image with superimposed VOL-Box or using a 2D+Color image. In case of a 2D+Color image the Color-Box may be at the same time the VOLBox. The 2D start image represents the central 2D scan of the volume. The volume scan itself sweeps from one margin to the other margin of the volume to be acquired.

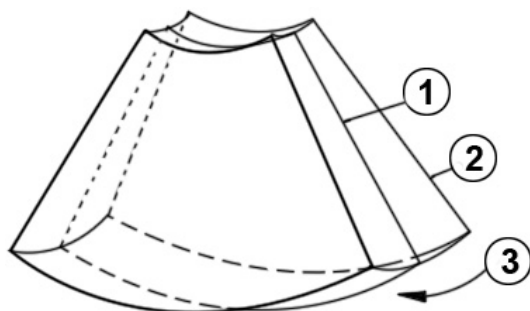

- 1. Central 2D scan
- 2. Start 2D scan
- 3. Range of VOL sweep

The volume scan is automatically performed by an automatic sweep of the transducer array inside the housing. The scanned volume is similar to a section of a donut.

Abdominal	Transvaginal

Table 8-1 Transducer types

VolPre mode

The VOL-Box frames the Region of Interest (ROI) on the actual 2D scan which will be stored during the volume sweep. The range of the volume sweep is indicated by the Vol-Angle Pictogram, which is displayed at the bottom right of the screen. This moving indicator gives information about the position of the B image during the 3D volume scan. The sweep time varies and depends on the VOL-Box size (depth range, angle) and the quality. The probe must be held steady and in place during the 3D volume scan. The real time display of the swept B frames allows continual observation of the scan quality. During the real time 4D scan it is not necessary to hold the probe steady because of the continuous volume acquisition.

8.1 Visualization

The position of the volume body in relation to the display plane is determined by a relative coordinate system. This is made up of three orthogonal axes. The common intersection of these axes is the central dot. These axes are displayed within the display plane - exactly in the X-, Y- and Z- directions and colored. Rotation around any of these axes and displacement of the center of rotation make any imaginable plane within the volume body displayable. The INIT position of the volume body in relation to the display plane is resettable; it is the start situation after completion of a volume scan.

The standard representation: 3 sectional planes The 3 orthogonal sectional planes are simultaneously displayed on the screen. Each quarter of the monitor displays a sectional view through the volume body as shown below.

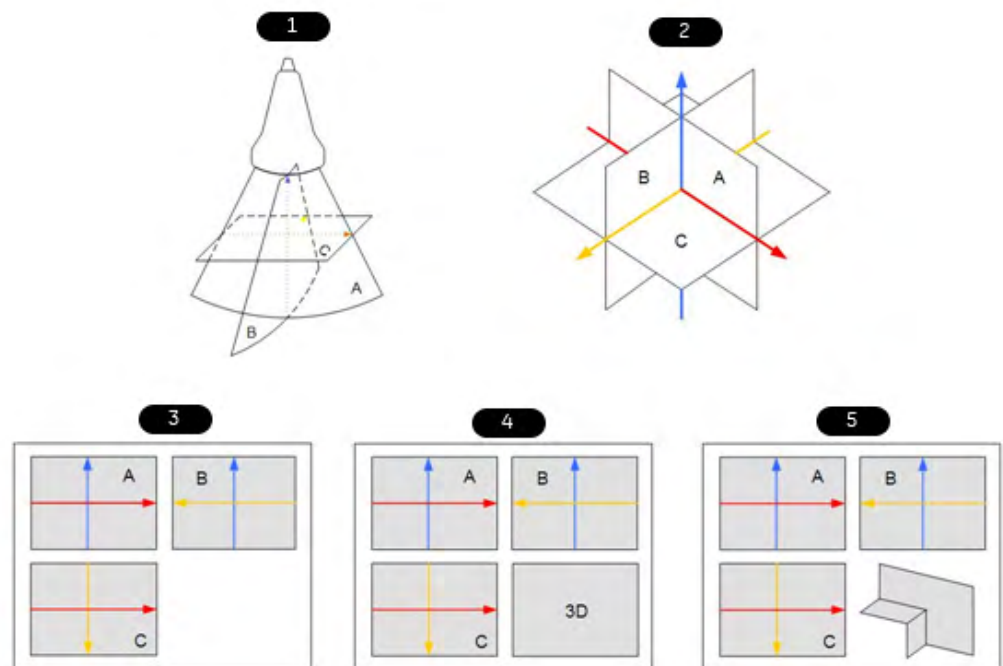

Figure 8-1 Sectional planes

1. Scan situation (init. condition)
2. Sectional planes
3. Visualization Mode: Multiplanar
4. Visualization Mode: Render
5. Visualization Mode: Niche

The intersection lines of the planes are displayed in colors:

AB = blue AC = red BC = yellow

Orientation of intersection lines on the screen:

Section/field	A	B	C	
Intersection line AB	V	V	P	V = Vertical
Intersection line AC	H	P	H	H = Horizontal
Intersection line BC	P	H	V	P = Perpendicular

By this definition the relation of the position of the 3 images A, B, C is also indicated (as made clear by the direction of arrows). The presentation of 3 orthogonal sectional planes may lead to non-

conformance with the conventional customized orientation to the patient in 2D-sonography. An identification system - the automatic display of the direction of section - will clarify.

Please note:

Whenever a usual longitudinal section (of the patient) is selected for display field A, the usual orientation for longitudinal and transverse sections is valid.

The display screen shows the sectional plane located within the volume, which has been selected by rotating and shifting of the volume body in relation to the display plane.

Rotation of the volume body in relation to the display plane

The volume body can be rotated around the X- or Y-axis of the display plane, or the Z-axis which is perpendicular to the display plane.

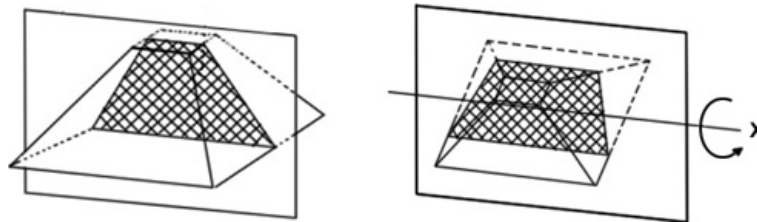

While turning a rotary control, the corresponding axis is shown in the reference image as a line (X- or Y-axis) or as a circle (Z-axis). Rotations around any one of the axes X, Y and Z can be performed freely.

Hint

- For faster rotation push on the rotary controls once (toggle function: slow rotation, fast rotation) Press again to return to slower rotation.
- Rotation should be performed slowly to understand the orientation.
- Do not rotate by large angles except when the orientation left/right or up/down is to be changed. At 90° rotation around an axis, the sections A, B, C will change:
- Reference image e.g., A: X-axis: A ´ C Y-axis: A ´ B Z-axis: B ´ C
- Before performing a rotation, position the center of rotation in the area of the image that you want to keep.

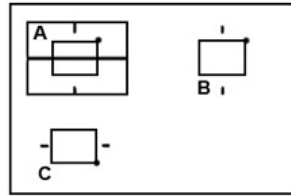

Use the **X** rotary control to rotate around the X-axis

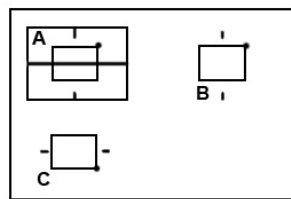
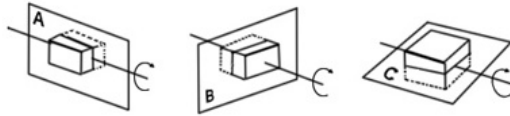

Use the **Y** rotary control to rotate around the Y-axis

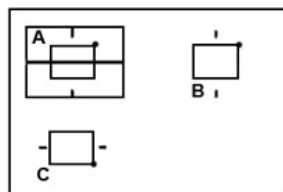
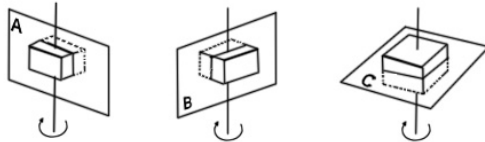

Use the **Z** rotary control to rotate around the Z-axis

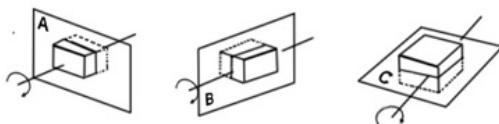

By rotation of the volume body in relation to the screen plane (as shown) the new sectional planes are calculated in real time and displayed on screen.

Displacement of the volume body relative to the display plane

The translation allows a displacement of the center of rotation along the intersection lines of the sectional planes A, B and C. The displacement of the center of rotation leads to the display of parallel sectional images.

To perform parallel slicing of images rotate the **Parallel shift** rotary control.

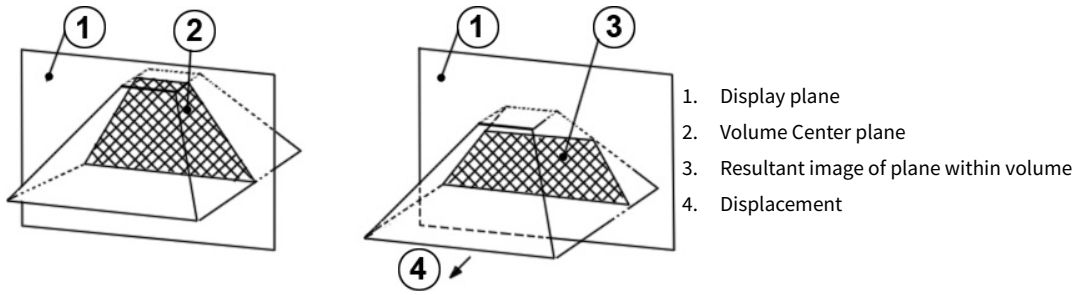

1. Display plane
2. Volume Center plane
3. Resultant image of plane within volume
4. Displacement

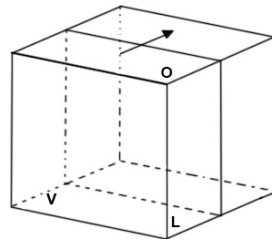

Reference image: A
The sectional plane migrates from the front to the rear through the volume body.

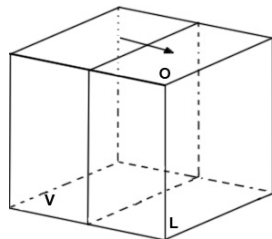

Reference image: B
The sectional plane migrates from the left to the right through the volume body.

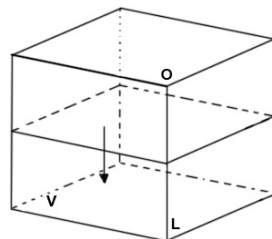

Reference image: C
The sectional plane migrates from the top to the bottom through the volume body

Parallel movement of the reference image will display the new intersection lines with the non-reference images. The sectional planes of the non-reference images are not altered.

Note *The terms “front, left, top” etc., do **not** refer to the patient, but serve for explanation.*

The center of rotation can be X/Y-positioned by the trackball. This causes also a parallel displacement of those planes presented by the non-reference images. The intersection line of the non-reference images with the reference image will undergo a parallel X or Y shift accordingly.

- Note**
- *Positioning the center of rotation in the reference image marks that point which will not get lost during the rotation.*
 - *It is recommended to use the **Parallel shift** rotary control together with the reference selection for the performance of parallel sections. In this mode only one image is concerned by changes.*

Note *The center of rotation cannot leave the display field A, B or C. In case an intersection line reaches the volume border, the line will stay there and the image (with further shift) will continue to move in the shift direction. This is especially helpful when due to magnification the display field is small compared with the area of the plane to be observed.*

8.2 General advice to obtain good rendered 3D/4D images

B-Mode

- Poor quality of the volume scan will lead to a poor quality 3D image.
- For a good 3D image quality, adjust high contrast in 2D mode of the interesting structures before starting the volume scan.
- Only the ultrasound data within the ROI (render box) will be calculated and displayed.
- The correct placement of the ROI is essential for a good result, because the ROI determines the view onto the interesting object.
- **Surface Mode:** note that the surface of interest has to be surrounded by hypo echoic structures; otherwise the system is unable to define the surface. With the function "THRESHOLD" echo structures adjacent to the surface can be "cut off" if their gray values are much lower than the gray values of the surface structures.
- **Minimum Mode:** note that the interesting objects (vessels, cysts) should be surrounded by hyper echoic structures. Avoid dark areas (shadows caused by attenuation, dark tissue presentation) within the ROI, otherwise large parts of 3D images will be displayed dark.
- **Maximum Mode:** avoid bright artefact echoes within the ROI, otherwise these artefacts are displayed in the 3D images.
- **X-Ray Mode:** note that all gray values within the ROI are displayed. Therefore, in order to enlarge the contrast of the structures within the ROI, the depth of the ROI should be adjusted as low as allowable.

Color Mode

- Poor quality of the Color image in 2D mode will lead to poor image quality in 3D color image.
- In Power-Doppler mode (control "PD") a pure flow display without directional coding is given.
- Use small VOL box and small sweep angle to reduce acquisition time.
- Smoothing Filter (Rise and Fall in 2D image) leads to smoother flow and a good color 3D display of vessels (e.g., filtering of high pulsatile vessels). Disadvantage: The higher the filter setting, the longer the acquisition time.
- **Surface Mode:** Displays the surface of the vessels (color signals) within the tissue volume.

Note *If the Mix control is adjusted to 100% color, the gray scale tissue information becomes transparent.*

8.3 Initial Condition of different Probes

Touch the **Init** button on the touch panel to reset the rotations and translations of a volume section to the initial (start) position.

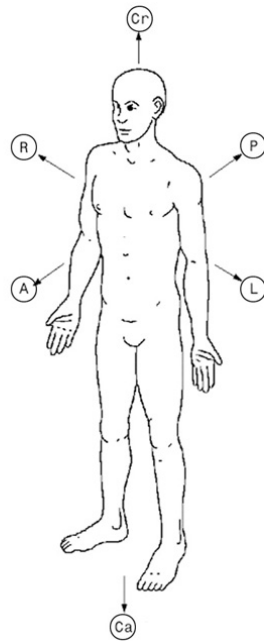

- A - anterior (ventral)
- P - posterior (dorsal)
- Cr - cranial
- Ca - caudal
- R - right
- L - left

Table 8-2 Directions

The sectional image A represents the 2D image visible in the Vol preparation area.

If the VOL-start image is a longitudinal section (Cr on the left of the screen below), the following Init positions are obtained:

A	A
Cr Longitudinal Ca	R Transversal L
P	P
L	
Cr Horizontal Ca	
R	

Table 8-3 Init condition of an abdominal probe

If the VOL-start image is a longitudinal section (Cr on the left of the screen below), the following Init positions are obtained:

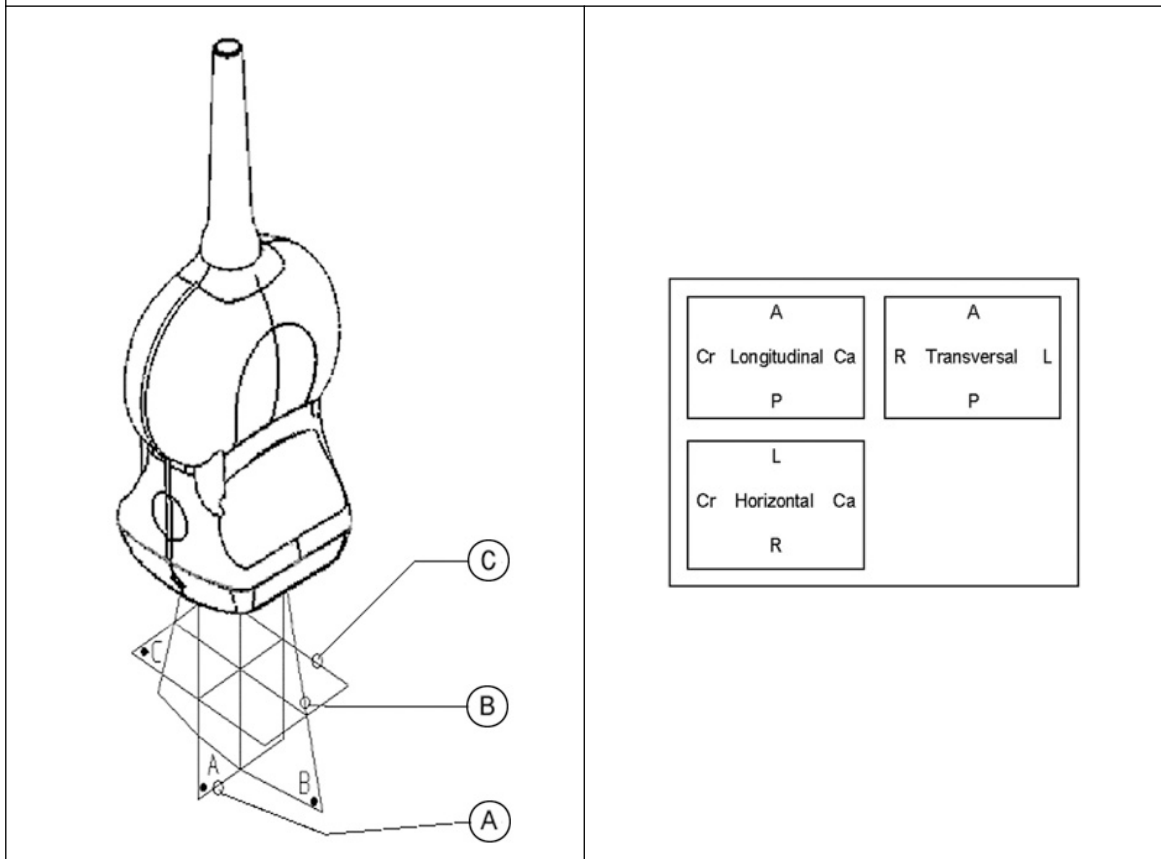

Table 8-4 Init condition of an small parts probe

If the VOL-start image is a median-sagittal section (left side of the screen is posterior), the following Init positions are obtained:

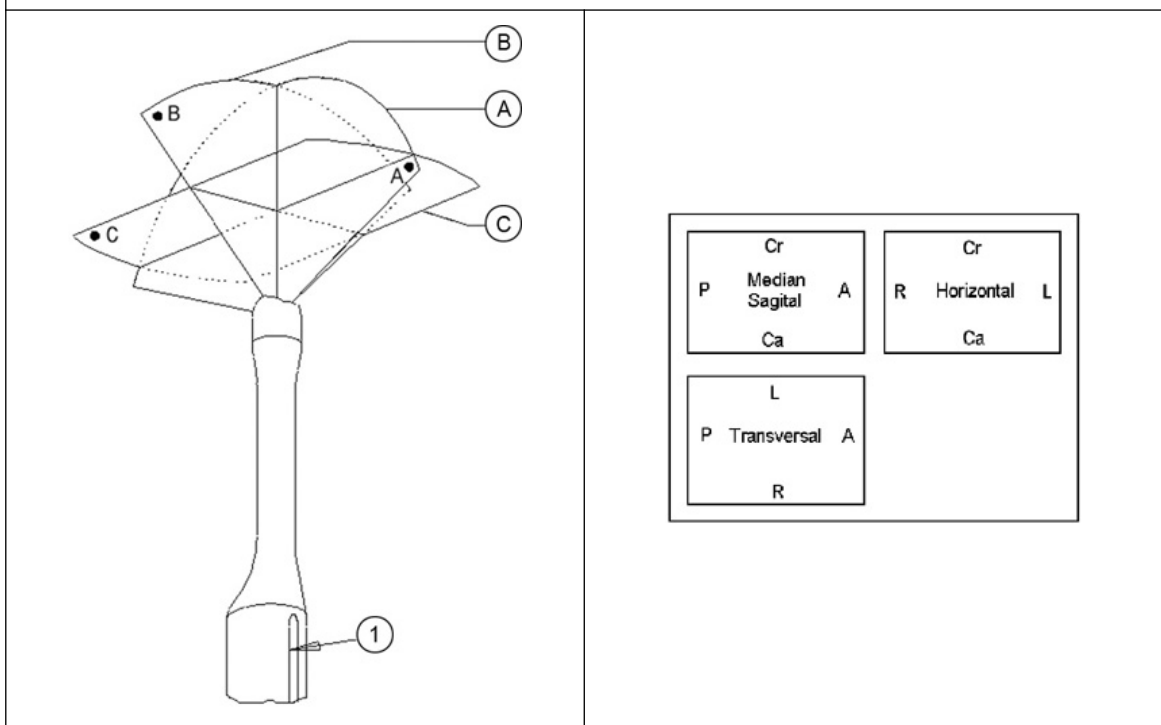

Table 8-5 Init condition of an endocavity probe

8.4 3D/4D Mode screen display

The 3D/4D Mode screen display consists of the ultrasound image, the Volume Box, the VolAngle Indicator, the Render Box, the x,y and z axis, the axis center point, a Ref. Image Icon, the Scale Marker, Image info and the Light position Icon.

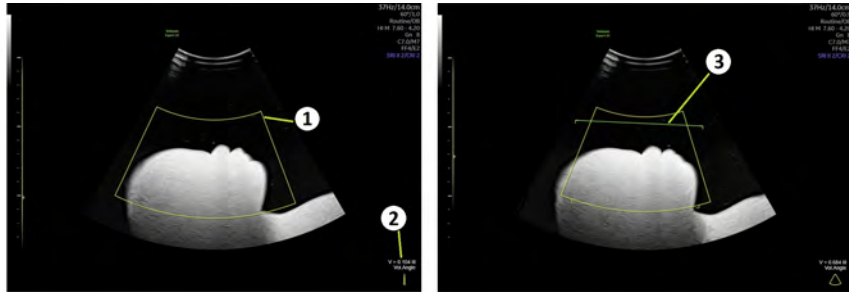

Figure 8-2 Pre Mode screen display: Multiplanar & Render

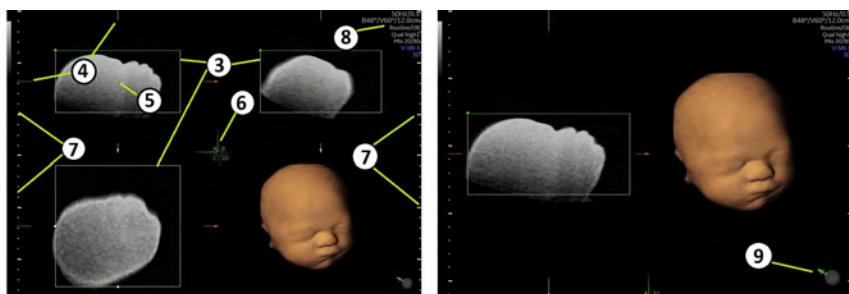

Figure 8-3 Scan- & Freeze-Mode screen display: Render

Volume Box

Screen reference: 1

The three dimensional Volume Box is displayed with help of two boxes, which are rectangular to each other. All information inside the Box during the volume acquisition will be recorded and stored in the volume memory.

VolAngle Indicator

Screen reference: 2

In 3D/4D pre mode the range of the volume sweep is indicated by the VolAngle Indicator, which is displayed at the bottom right of the screen. This indicator shows the actual position of 2D system during a volume sweep, moving from start to end position of adjusted volume angle filling the symbol. The filled color area shows the progress of the acquisition procedure.

Biplane Mode: Instead of the VolAngle Indicator the Volume Box is displayed on the orthogonal plane B.

Render Box

Screen reference: 3

The render box determines the ROI (content) of the volume data set to be rendered.

To obtain a good 3D picture, the following three points are very important (similar to a photography):

- the direction of view
- the area/size of view
- unobstructed view of the object (surface mode)

This has to be adjusted with the render box. The render box determines the size of the volume to be rendered. Therefore, objects that are not inside the box will not be included in the render process and cut out (important for the surface mode to cut off objects, which obstruct the view of the object).

The positioning of the box inside the scanned volume is performed by trackball and selection of a sectional plane A, B, C.

x,y,z axis

Screen reference: 4

The axis represent the relative coordinate system and mark the intersection lines of the slices.

Axis center point

Screen reference: 5

The axis center point marks the intersection point of the three axis x,y and z.

Ref. Image Icon

Screen reference: 6

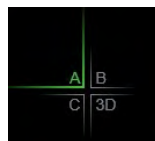

The Ref. Image Icon displays the state of the selected Ref. Image.

Scale Marker

Screen reference: 7

The depth scale marker allows to determine the depth of the echoes or objects displayed in the ultrasound image on sent or printed images.

Three depth scale markers are available:

- Large marker: represents 5cm in depth
- Medium marker: represents 1cm in depth
- Small marker: represents 5mm in depth

Image info

Screen reference: 8

reduced	full	Info Annotation (examples)	Description
-	x	---- 3D/4D ----	Header
x	x	50Hz/0.9/Px°	3D/4D Frame rate / Magnification Factor / Perspective Rendering
x	x	B48°/V60°/12.0cm	B-Mode angle / Volume sweep angle / Vol. Box Depth length
x	x	Program / Application	3D/4D User Program
x	x	Q. high1	Volume sweep Quality (not available at STIC Slowflow3D)
x	x	Mix20/80	Mix value between render main mode (70) and render sub mode (30) Only displayed in Visualization Mode Render & VCI.
-	x	S.sm/T.max	Render Mode 1 & 2
-	x	Th48/Tr40	Gray threshold, Transparency Gray (Render Mode)
-	x	M-13/10	Gray 3D, low / high tone (3D/4D Sub - menu)
x	x	S2mm	Slice thickness Only displayed in Visualization Mode VCI.
x	x	CRI 2/ SRI 3D 3	CRI and or SRI 3D (or V-SRI) value: Only displayed if one of the filters is active.

reduced	full	Info Annotation (examples)	Description
x	x	4D Real Time *	Current Acquisition Mode
-	x	--- 2D ---	Header
-	x	User Program	Name of user program
-	x	12.50-3.40	Receiving Bandwidth
-	x	Gn -3	B-Mode Gain [db]
-	x	C7/M7	Dynamic Contrast / Gray map
-	x	P4/E2	Persistence / Edge enhancement
-	x	SRI II 1	Speckle Reduction Imaging Filter
-	x	--- CFM ---	or other Color modes
-	x	Gn 2.1	Gain [dB]
-	x	Frq mid	CFM frequency
-	x	Qual norm	Quality of CFM
-	x	WMF low	Wall motion filter
-	x	PRF 1.8kHz	Velocity Range [KHz, cm/s, m/s]
-	x	Th55/S4/4	Color Threshold/ Smooth raise/fall

Table 8-6 Image info



Caution

A lossy image compression can reduce image quality which can lead to a false diagnosis!

Light position icon

Screen reference: 9

The light position icon indicates the current position of the light source.

8.5 Volume Acquisition Modes

8.5.1 3D Static

The acquisition of volume data sets is performed with special transducers designed for 3D/4D imaging. A volume data set consists of a series of 2D Images. The volume acquisition is started using a 2D image with superimposed VOL-Box. The 2D start image represents the central 2D scan of the volume. The volume scan itself sweeps from one margin to the other margin of the volume to be acquired.

Visualization Modes

After the 3D acquisition the following visualization modes are available:

- 'Render' on page 8-22
- 'Multiplanar' on page 8-24
- 'OmniView' on page 8-26
- 'TUI (Tomographic Ultrasound Imaging)' on page 8-28
- 'Volume Analysis' on page 8-20

3D Pre Menu (example)

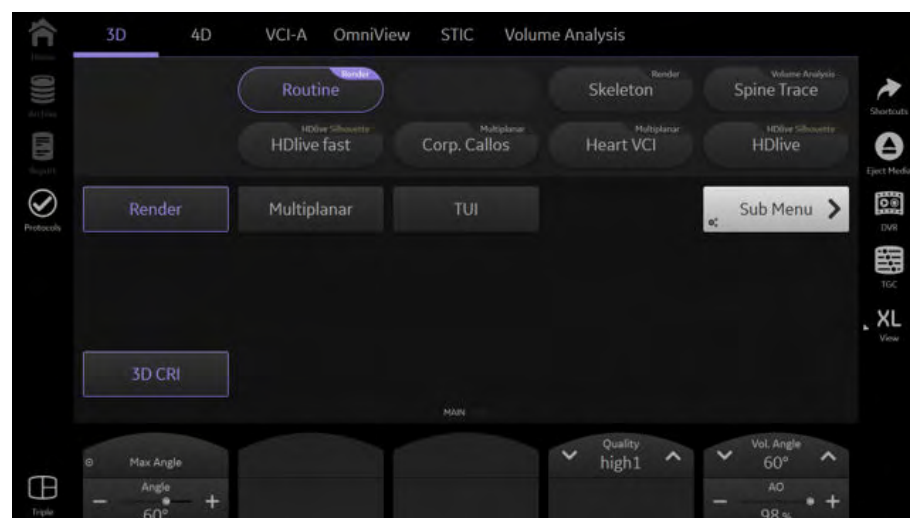

8.5.2 4D Real Time

Real Time 4D mode is obtained through continuous volume acquisition and simultaneous rendering. In Real Time 4D mode the volume acquisition box is at the same time the render box. All information in the volume box is used for the render process. Therefore size and position of the volume box is important for a good render result. After freezing, the image size can be adjusted manually if desired, or play back the Volume Cine.

A 3D static volume scan has a higher resolution than a 4D Real Time volume scan and therefore is better suitable to do high resolution image analysis after scanning.

Following adjustments are taken from the current 4D acquisition:

- 3D volume box size and position
- visualization mode
- acquisition quality

- current image settings (render mode, mix,...)

By pressing **Volpre** 4Dpre is activated again together with the same adjustments and settings as before the 3D scan. Depending on the system setup configuration the current 4D cine is saved before the 3D Static scan is started.

Note *Depending on the System Setup configuration the **3D** and/or **Volpre** button can be disabled in Freeze mode.*

4D Pre Menu (example)

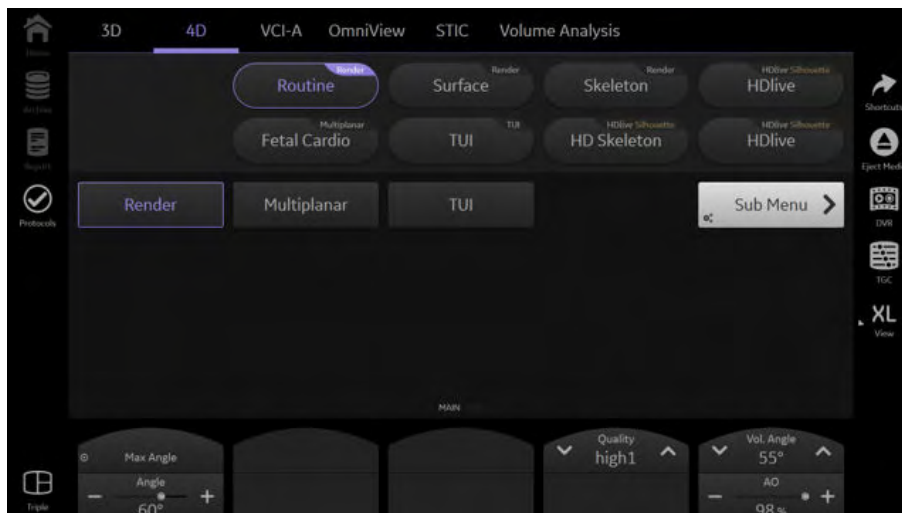

Visualization Modes

After the 4D acquisition the following visualization modes are available:

- 'Render' on page 8-22
- 'Multiplanar' on page 8-24
- 'OmniView' on page 8-26
- 'TUI (Tomographic Ultrasound Imaging)' on page 8-28

Cine gaps

If a data-interruption occurs during 4D mode, e.g. 4D, VCI-A, Omniview, etc. (not applicable for STIC) the cine gap is indicated by the  icon, which is displayed next to the active reference image/ Overview Window.

8.5.3 OmniView

With help of OmniView sectional planes derived from an entered trace can be visualized and so special coronal planes are possible. The trace can be entered in the Vol. Pre image or if a volume data set is present on image A, B or C. The trace can be a straight line, a curved line or any freeform trace. Together with the VCI function images with less speckle pattern and a highly improved tissue contrast can be archived.

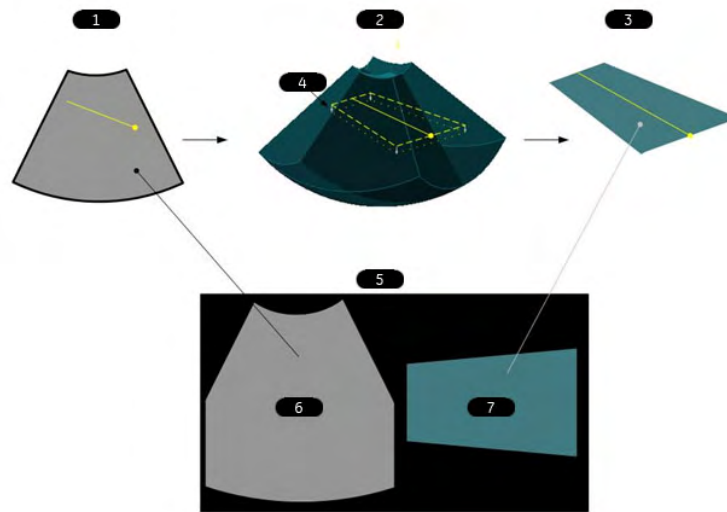
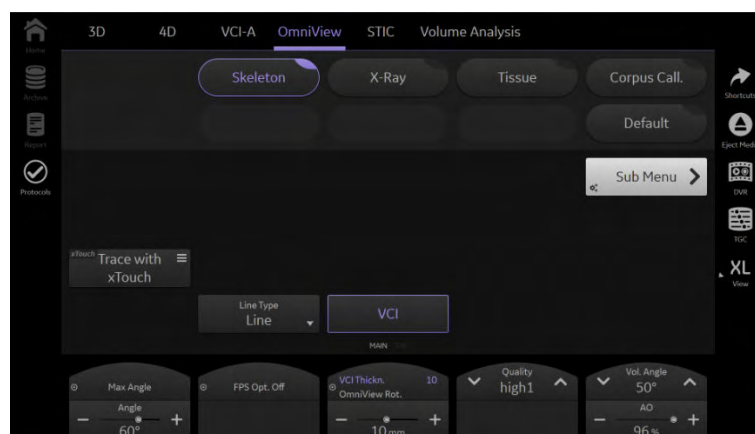

Figure 8-4 OmniView

1	OmniView pre mode: Entered OmniView line in center position of Vol. sweep
2	Acquired Volume block: dashed line: plane position orthogonal to the center image dotted line: VCI (slice) thickness
3	Calculated result: OmniView image including VCI rendering if on
4	Render direction
5	Screen display
6	Ref. Image
7	OmniView image

OmniView Pre Menu (example)



OmniView xTouch (Trace with xTouch)

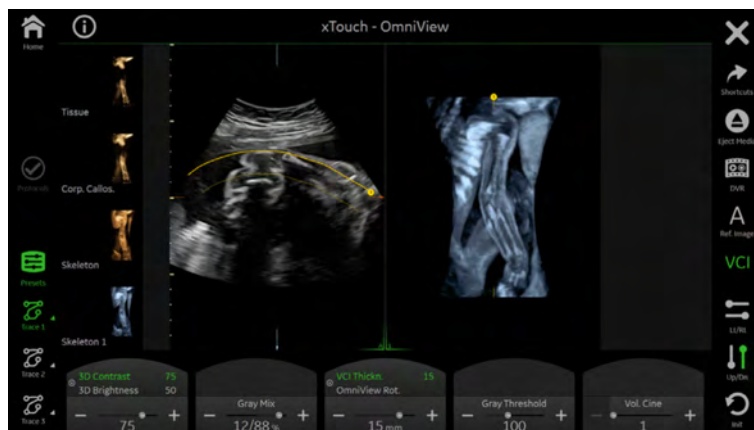

OmniView VolPre Menu

Line Type	Four tracking line methods are available: <ul style="list-style-type: none"> ● Line: straight line ● Curve: curved line ● Trace: freeform line ● Polyline: freeform line from point to point
Dual Display format	Select the desired display format (on the user interface).
VCI	Enable/disable and adjust VCI .
VCI Thickness	Select the desired thickness (mm).
Angle	Adjusts the Image Angle.
Trace with xTouch	Opens the xTouch OmniView Menu.
FPS Opt.	On/off selection. Optimization of the 4D frame rate related to the position of the OmniView trace through the reduction of the scanned volume depth.
OmniView rot.	Rotates OmniView.
Cine Speed	Regulates the replay speed of the cine.
Quality	This control improves the resolution by reducing the frame rate. Respectively it reduces the resolution by increasing the image frame rate.
Vol. Angle	Adjust the Volume Angle.
AO	Adjusts the Acoustic Output.

8.5.4 STIC (Spatio-Temporal Image Correlation)

STIC

Note *STIC is an option.*

Note *Read 'Operation safety' on page 2-21 before using this feature.*

With this acquisition method the fetal heart or vascularity can be visualized in 4D. It is not a Real Time 4D technique, but a post processed 3D acquisition.

STIC is designed for beating (fetal heart) as well as blood perfused organs.

Data is acquired for a predefined period of time (7.5 – 15 sec.). The acquired images are post processed to calculate a 4D Volume Cine sequence representing one complete heart cycle. For reconstruction of the heart cycle, the pulsation of the heart or blood perfused organs is evaluated. Pulsations both at maternal and fetal heart rates can be detected. For anatomy where fetal heart rate

detection is needed, choose application specific settings “Obstetrics”. For anatomy where maternal heart rate detection is needed, choose application specific settings “Gynecology”.

In order to achieve a good result, try to adjust the size of the volume box and the sweep angle to be as small as possible. The longer the acquisition time, the better the spatial resolution will be. The user must be sure that there is minimal movement of the participating persons (e.g., mother and fetus), and that the probe is held absolutely still throughout the acquisition period. Movement will cause a failure of the acquisition. If the professional user clearly recognizes a disturbance during the acquisition period, the acquisition has to be canceled.

A good STIC data set shows a regular and synchronous beating of the fetal heart or of an artery. Please make sure that the borders of the fetal heart or the artery are smooth and there are no sudden discontinuities. Always adopt a critical attitude to images created in STIC mode.

One or more of the following artefacts in the data set indicate a disturbance during acquisition:

- Sudden discontinuities in the reference image B: These are due to motion of the mother, the fetus or fetal arrhythmia during acquisition.
- Sudden discontinuities in the color display: Motion of the mother, the fetus or fetal arrhythmia affects the color flow in the same way it affects the gray image.
- Fetal heart rate far too low or far too high: After acquisition the estimated fetal heart rate is displayed. If the value does not correspond to the estimations based on other diagnostic methods at all, the acquisition failed and has to be repeated.
- Asynchronous movement in different parts of the image: e.g., the left part of the image is contracting and the right part is expanding at the same time.
- The color does not fit the structures displayed in gray mode: The color is displayed above or below the actual vessel.
- Color “moves” through the image in a certain direction: This artefact is caused by a failure in detecting the heart rate due to low acquisition frame rate. Use higher acquisition frame rate for better result.

Note *In all of the above cases the data set has to be discarded and the acquisition has to be repeated.*

When is it not allowed to perform the STIC fetal cardio acquisition?

- severe fetal arrhythmia

Screen Layout

In STICpre / CFM STICpre mode all items are identical with 4D RT pre mode / 4D CFM RT pre mode.

In STIC / CFM STIC data all items are identical with 4D RT mode / 4D CFM RT mode. The caution icon and the calculated heart rate are displayed as well.

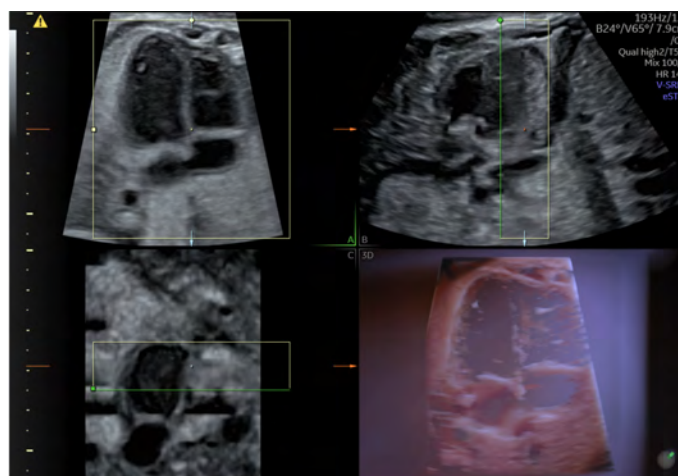

Figure 8-5 Screen layout

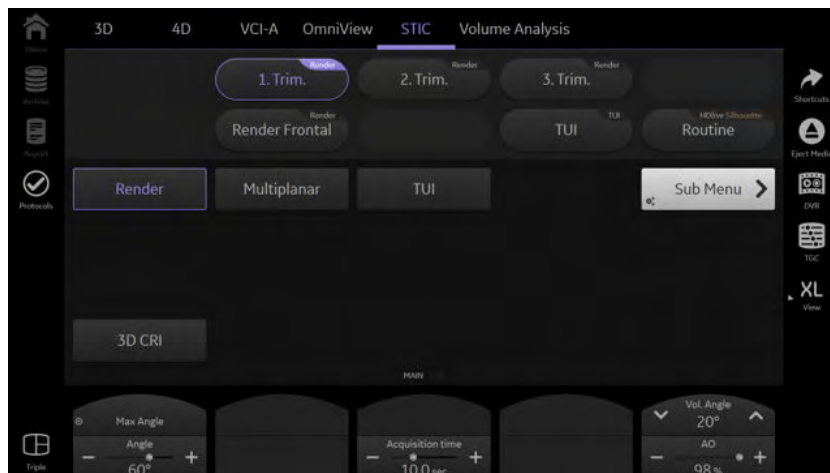

Figure 8-6 Touch panel layout (example STIC)

All hard key and trackball controls are the same as in 4D RT / 4D CFM RT mode. Therefore only the STIC relevant controls are described here:

Quality	Select the desired quality: max2, max1, high2, high1, mid2, mid1, low
Acqu. Time	Only available in STIC. Acquisition time (7,5 sec, 10 sec, 12,5 sec, 15 sec) can be set.
Volume Angle	Adjusts the volume angle as in 4D RT mode.
Exit/Stop Acquisition	If more than 50% of the acquisition is done, use the acquired data or return to pre mode. If the system fails the calculation the message "Insufficient data for Heart Rate calculation. Please repeat." appears in the message area for 3 seconds.
STIC Trigger	The STIC Trigger setting defines on which data the STIC algorithm operates. In Color STIC mode this can be either the grayscale 2D data or the Doppler data. Grayscale data are used for the acquisition of the fetal heart, Doppler data are used for the acquisition of vascular structures.

Visualization Modes

After the STIC acquisition the following visualization modes are available:

- 'Render' on page 8-22
- 'Multiplanar' on page 8-24
- 'OmniView' on page 8-26
- 'TUI (Tomographic Ultrasound Imaging)' on page 8-28

Note For setting the desired cine start position open **Edit Clip** on the trackball and press the button **Set Start**. Any volumes before this position are added at the end.

8.5.5 VCI-A

Note VCI-A availability is option depending.

By setting a small volume sweep angle you scan a limited number of slices with a relatively high volume rate. The render box is very narrow and so you can visualize the tissue information of a thick slice. The resulting image shows the average (integrated) gray values of the tissue contained within the narrow box. Volume Contrast Imaging [VCI] improves the contrast resolution and the signal / noise ratio and therefore facilitates the detection of diffuse lesions in organs. The result is an image with no speckle pattern and a highly improved tissue contrast.

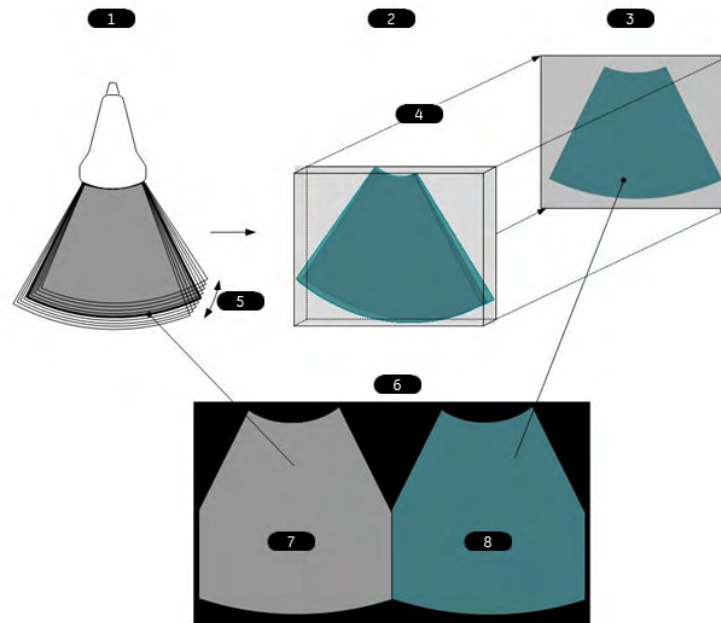

Figure 8-7 VCI-A principle

1	Scan Situation: small 4D volume sweep Vol. angle depends on slice thickness
2	Render Box: Box size automatically derived from Vol. geometry. Box not shown on screen.
3	Render result: All single B-frames are rendered to one single VCI image (Thick Slice Image).
4	Render direction
5	Vol. angle
6	Screen Display
7	Standard Image (center position of Vol. sweep)
8	VCI Image (Thick Slice rendered Image)

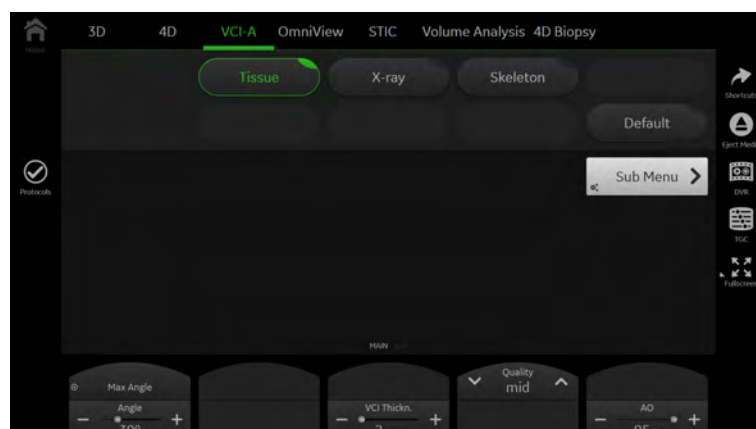

Figure 8-8 VCI-A pre menu (example)

Slice Thickness

Select the desired slice thickness.

Invert

Inverts the colors.

Acquisition Size	Select between "CFM Box size" and "Sector size". Default: "CFM Box size"
VCI Thickness	Select the desired thickness (mm).
Sub CFM	Opens Sub CFM Menu.
Init	Sets all sliders to middle position.
TGC	Opens the TGC menu.
Thickn.	Displays the slice thickness.
Quality	This control improves the resolution by reducing the frame rate. Respectively it reduces the resolution by increasing the image frame rate.
AO	Adjusts the Acoustic Output.

Visualization Modes

- 'VCI-A' on page 8-34

8.5.6 4D Biopsy

Note *4D Biopsy is an option.*

Before using 4D Biopsy the biopsy lines must be programmed. For more information see 'Biopsy setup' on page 5-28.

Before using biopsy equipment read the safety precautions. For more information see 'Biopsy safety' on page 5-25.

Visualization Modes

- '4D Biopsy' on page 8-35

8.5.7 Volume Analysis

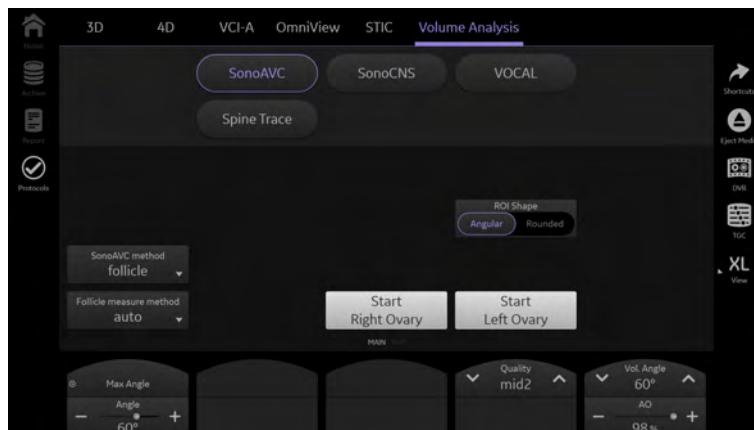

Figure 8-9 SonoAVC™ pre (example)

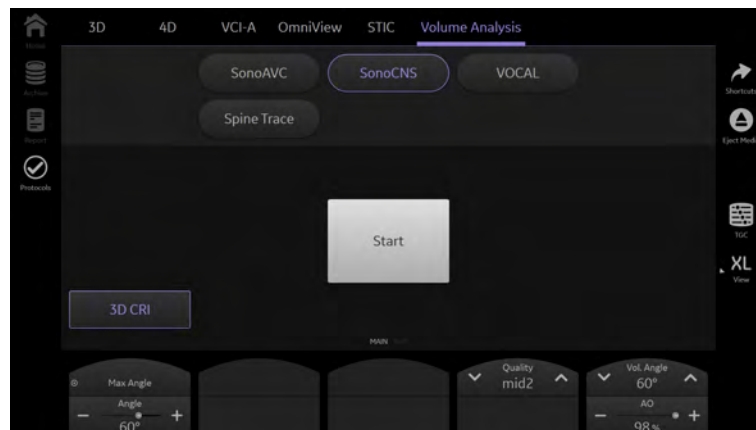

Figure 8-10 SonoCNS pre (example)

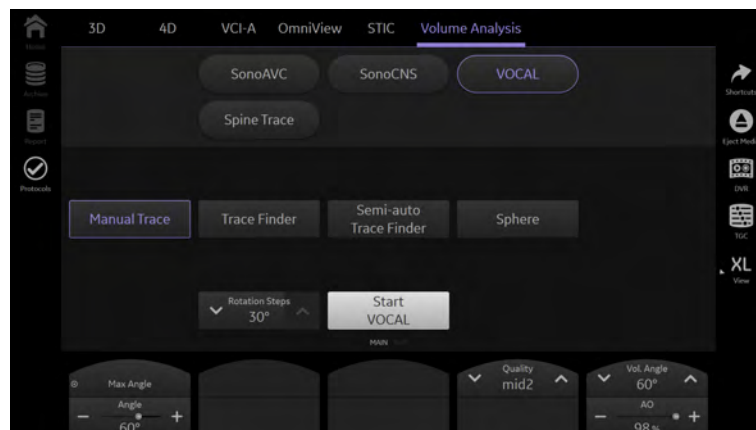

Figure 8-11 VOCAL pre (example)

Volume Analysis

For more information, visit the following chapters:

- 'SonoAVC™follicle' on page 8-54
- 'SonoAVC™antral 2.0' on page 8-58
- 'SonoAVC™general' on page 8-60
- 'SonoCNS' on page 8-62
- 'VOCAL II' on page 8-52
- 'Uterine Trace' on page 8-66
- 'SonoPelvicFloor' on page 8-64
- 'Spine Trace' on page 8-71
- 'Fibroid Mapping' on page 8-68

8.6 Volume Visualization Modes

8.6.1 Render

Possible Acquisition Modes:

- 3D Static
- 4D Real Time
- STIC

Button description for all menus: see below.

Render Menu

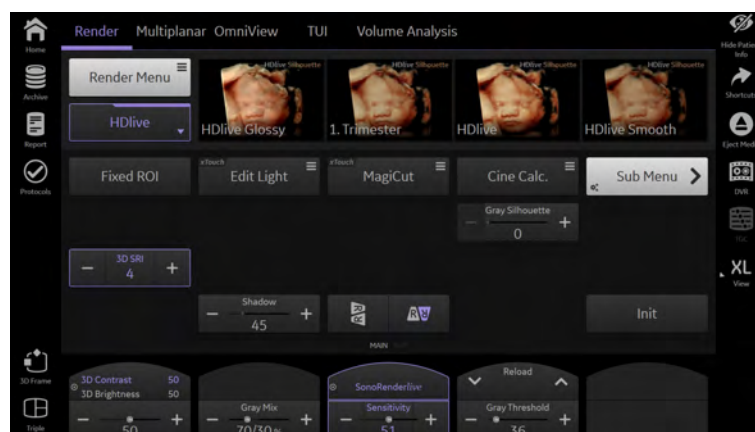

Figure 8-12 Example: 3D Static

Main Menu / Sub Menu	Select the Main Menu or the Sub Menu.
Render Menu	Open the Render Menu.
3D: SRI	Applies the filter to the rendered 3D image only.
2D: SRI	Applies the filter to the rendered 2D image only.
3D Brightness	Adjust the brightness.
3D Contrast	Adjust the contrast.
Gray Mix	Render mix mode: toggles between the two selected render modes and Gray Threshold low for 3D images.
Gray Threshold	Gray Threshold is used for surface render modes of B-Mode images. The gray values or color values beyond the threshold are not used/shown in the rendered 3D image. During adjustment these values are displayed temporarily with pink color on the images A, B and C.
SonoRenderlive	Select SonoRenderlive .
Shadow	Adjust the shadow.
Smooth	Improve the render image quality for high line densities.
Gray Silhouette	Emphasize the contour of surface structures.
Gray Transparent	Adjust the gray transparency.
Calc Cine	Displays the Cine Calculations menu.
Ref. Image	Select the reference image to which all image dependent functions like parallel shifts, rotations, etc. are applied.
Init	The Init position is the position as present after starting a new acquisition. Tap onto the button to reset all values back to initial position.

TGC	Double tap onto the button to reset the TGC sliders to the default position.
Vol. Angle	Adjust the volume angle (sweep angle).
Acoustic Output	Adjust the acoustic output (acoustic power).
Quality	Adjust the quality (volume line density).
Background	Adjust the background.
Multiplanar Image SRI	Select SRI for multiplanar images.
3D Image SRI	Select SRI for 3D images.
3D Frame	Frame the border of the 3D image.
Tint 3D	Open the Tint 3D menu.
Tint 2D	Open the Tint 2D menu.
Gray Map	Select the desired map.
Probe Orientation	Open the Probe Orientation menu.
Render Direction	Open the Render Direction menu. The active render direction is displayed on the Render Direction button.
Info 2D Param.	Display additional imaging parameters on screen.
Persistence	Adjust the persistence filter for volume cine images.
B-Mode Quality	Adjust the reverberation suppression.
Cine Speed	Regulates the replay speed of the cine.
Edit Light	Opens the xTouch Edit Light menu. The Light source position can be also changed with the trackball to any position or with the preset buttons to dedicated positions. The current position is shown with help of the Light Icon.
MagiCut	Opens the xTouch MagiCut menu.
3D CRI	Select the 3D CRI function independent from B-Mode imaging.
Angle	Adjust the angle.
Volume Analysis	Open the Volume Analysis menu.
Format / Display	Select the desired format / display (Single, Dual, Triple, XL View, 3D Rotation, Fixed ROI)
Silhouette Radius	Adjust the radius. (Only available with HDlive™ <i>Silhouette</i> .)
Silhouette Threshold	Adjust the threshold. (Only available with HDlive™ <i>Silhouette</i> .)

8.6.1.1 SonoRenderlive

SonoRenderlive helps to find the render start position to easily separate solid tissue in front of the render object.

The SonoRenderlive algorithm “looks” for the transition from solid to liquid tissue and positions the “Render Start” into the liquid area visualized by the green render start line. The render start line is not a straight line but a “free” trace for optimal adaptation to the render object.

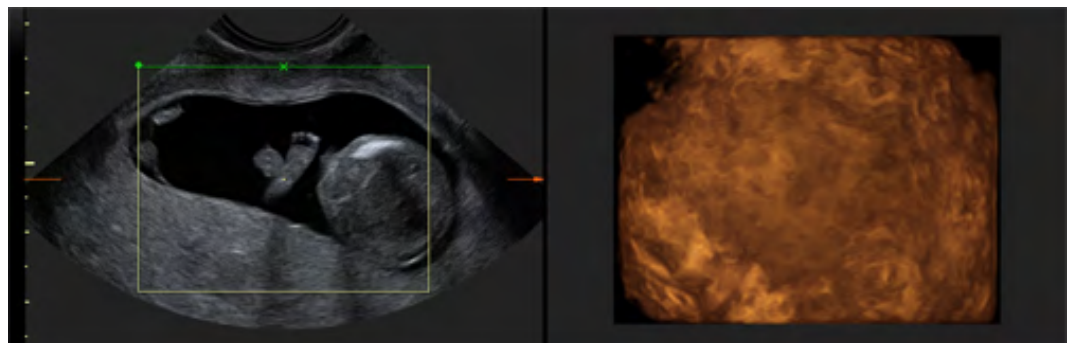

Figure 8-13 Screen display: SonoRenderlive

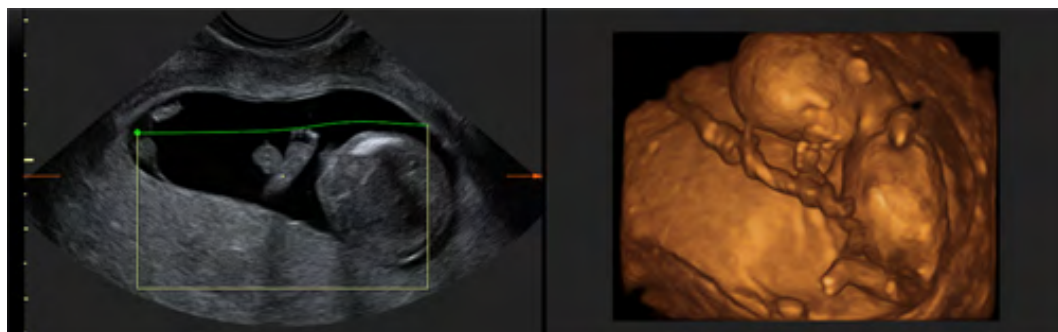

Figure 8-14 Screen display: SonoRenderlive

Using SonoRenderlive

1. Start the Render Visualization Mode.
2. Press the **SonoRenderlive** touch panel control.

Note *SonoRenderlive can also be activated (one click)/deactivated (double click) by pressing **Auto**.*

Note *In 3D/4D pre mode SonoRenderlive is only available as pre-selection (on/off). **Sensitivity** is not available then.*

3. To adjust the distance between the render start position and the render object, use the +/- slider control. A high value indicates a smaller distance.

Info *In the case that **SonoRenderlive** is not used, the Render Start line can also be modified manually. Press the trackball button **Curv** to activate Curved Render Start and move the trackball to modify the line.*

Note *SonoRenderlive is not available in STIC combination modes (i.e. STIC CFM, STIC PD,...).*

8.6.2 Multiplanar

Possible Acquisition Modes:

- 3D Static
- 4D Real Time
- STIC

Button description for all menus: see below.

Multiplanar Menu

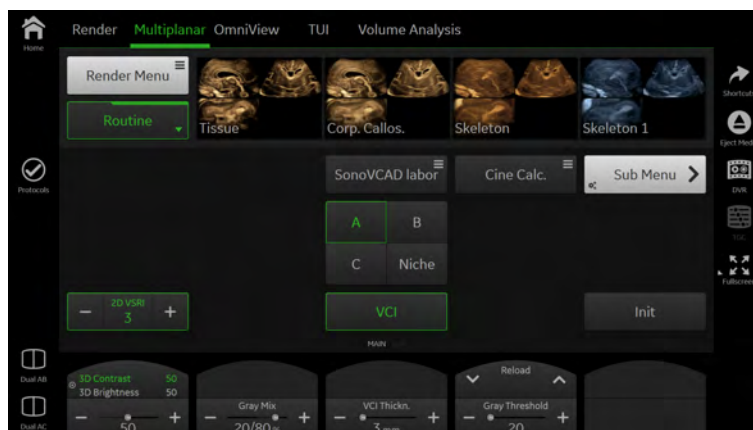

Figure 8-15 Example: 3D Static

Main Menu / Sub Menu	Select the Main Menu or the Sub Menu.
Render Menu	Open the Render Menu.
2D: SRI	Applies the filter to the rendered 2D image only.
3D Brightness	Adjust the brightness.
3D Contrast	Adjust the contrast.
Gray Mix	Render mix mode: toggles between the two selected render modes and Gray Threshold low for 3D images.
Gray Threshold	Gray Threshold is used for surface render modes of B-Mode images. The gray values or color values beyond the threshold are not used/shown in the rendered 3D image. During adjustment these values are displayed temporarily with pink color on the images A, B and C.
VCI	Select the desired thickness (mm).
Calc Cine	Displays the Cine Calculations menu.
SonoVCAD™labor	Displays the SonoVCAD™labor menu.
4D-AMM	Shows an M-spectrum of the STIC acquisition.
Ref. Image	Select the reference image to which all image dependent functions like parallel shifts, rotations, etc. are applied.
Init	The Init position is the position as present after starting a new acquisition. Tap onto the button to reset all values back to initial position.
TGC	Double tap onto the button to reset the TGC sliders to the default position.
Vol. Angle	Adjust the volume angle (sweep angle).
Acoustic Output	Adjust the acoustic output (acoustic power).
Quality	Adjust the quality (volume line density).
VCI Thickness	Select the desired thickness (mm).
Background	Adjust the background.
Multiplanar Image SRI	Select between SRI for multiplanar images.
Tint VCI	Select the desired tint map.
Tint 2D	Open the Tint 2D menu.
Gray Map	Select the desired map.
Probe Orientation	Open the Probe Orientation menu.
Orientation Help	Shows a model of the acquired 3D volume. Into this model (model shape depends on the used 3D/4D probe type), the system draws the position and orientation of the active reference plane. This view gives orientation help to decide which plane segment of the volume is rendered in the reference plane.
Info 2D Param.	Display additional imaging parameters on screen.
Persistence	Adjust the persistence filter for volume cine images.
Cine Speed	Regulates the replay speed of the cine.
B-Mode Quality	Adjust the reverberation suppression.
Niche	Activates Niche .
Format / Display	Select the desired format / display (Single, Dual AC, Dual AB, Quad)

8.6.2.1 4D-AMM/STIC-M

Note *4D-AMM and STIC is an option.*

With 4D-AMM/STIC-M it is possible to show an M-spectrum of a 4D or STIC acquisition. Basically it is an AMM mode using each single volume for one M-line. The M-data are derived along an entered M-

line. To show an M-image which fills the horizontal M image area the cycles are repeated several times.

To open 4D-AMM/STIC-M, press **4D-AMM/STIC-M** in Multiplanar menu.

Screen Layout

Following items are displayed:

- M Line on Multiplanar slice and M-image (red line always fixed at 1 sec of the time scale)
- M depth scale
- M time scale

When 4D-AMM/STIC-M is activated, the cross to set the M-line appears in the middle of the screen. M-image will be displayed after entering a line.

As the controls are the same as in 4D or STIC mode, only the 4D-AMM/STIC-M relevant controls are described here:

M-Speed	Adjusts the horizontal scale range from 1 sec to 4.5 sec.
Speed	Adjusts the scrolling speed. Only available in auto cine mode.
AMM rot.	Rotates the current M-line on the image.
Previous Line	The previous line is activated and available (otherwise grayed).

Trackball Controls

Change	Toggles between pos (moves the M-Line) and rot (rotates the M-Line).
Volpre	Goes back to Volpre mode.
New	Sets a new M-Line. The current M-Line is cleared and the cross to set a new line is displayed.
Start/Stop	Starts/Stops the volume cine.
Cine	Manual selection of single volume frames.
Set	Sets the first/second point of the M-Line.
Undo	Clears the first set point.
pos	Moves the slice image, not the M-Line.
Edit Cine	Change trackball state to edit cine mode.

Measurements

The measurement package is available for all STIC modes. At STIC-M all M-measurements are possible. A yellow caution icon is displayed on all report pages as well as a warning message appears when the report is transferred.

8.6.3 OmniView

Note *OmniView is an option.*

By setting the necessary sweep angle for the desired ROI, the system provides a coronal plane (OmniView). The rendering box is very thin and so you can visualize the tissue information of a thick slice. A mixture of surface texture and transparent maximum (or X-ray) rendering modes (70/30) plus a low setting of surface transparency (20-50) is used. The resulting image shows the average (integrated) gray value of the tissue contained within the narrow box. OmniView improves the contrast resolution and the signal / noise ratio and therefore facilitates the detection of diffuse lesions in organs. The result is an image with no speckle pattern and a highly improved tissue contrast.

Possible Acquisition Modes:

- 4D Real Time
- 3D Static
- STIC

OmniView Menu

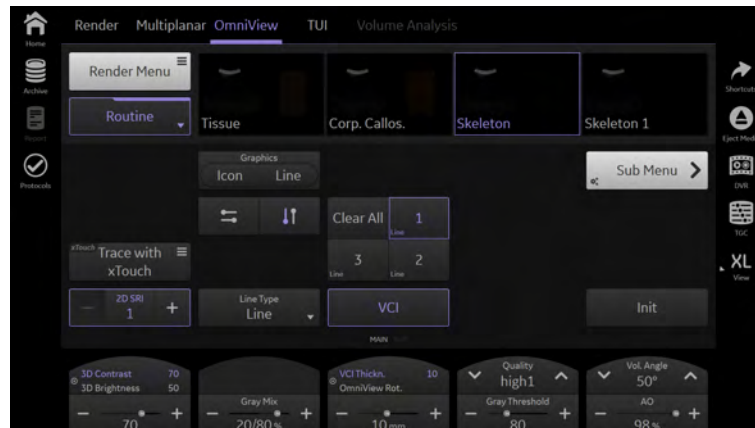

Figure 8-17 OmniView menu (example)

Render Folder	Select the desired render folder.
VCI Thickness	Select the desired thickness (mm).
Line Type	Four tracking line methods are available: <ul style="list-style-type: none"> • Line: straight line • Curve: curved line • Trace: freeform line • Polyline: freeform line from point to point
Clear All	All existing lines are deleted and a new line entry is started.
Orientation	Two toggle buttons: <ul style="list-style-type: none"> • Vertical: Up / Down • Horizontal: Left / Right The selected orientation is shown in green.
Init	Set all translations and rotations back to the initial acquisition position.
3D Contrast	Adjust the contrast.
3D Brightness	Adjust the brightness.
Gray Mix	Render mix mode: percentage-mix between the two render modes selected in the render modes menu.
Gray Threshold	Displays the Gray Threshold .
Trace with xTouch	Opens Trace with xTouch to draw the reference line for the acquisition.
Graphics: Icon / Line	Select between Icon (The icon shows the orientation of the OmniView slice in relation to the ref. slice.) and Line (Show or hide the OmniView Line.)
Cine Speed	Regulates the replay speed of the cine.
VCI	Set it on to visualize in render mode.
3D Color off	Turns off color.
Uterine Classification	Opens Uterine Classification .
Vol. Cine	Use the touch panel slider or rotary control to go through the volume cine frame by frame.
Gray/Tint Maps	Select the desired Gray/Tint Map.

OmniView Method	Choose the desired OmniView method (actual view or projected view).
Multiplanar Image	Select between Filter SRI
VCI Thicken. Mode	Select the desired VCI Thicken. Mode: <i>asymm.</i> (depending on the VCI Render Direction the slice thickness is added asymmetrically to the left or the right side of the entered OmniView line) or <i>symm.</i> (the slice thickness is added symmetrically to the entered OmniView line).
Persist.	Persistence filter for volume cine images.(0 = filter off, range: 1-8)
Probe Orientation	Open the Probe Orientation menu (under More).
Info 2D Param.	Display extended image information in the top right corner (under More).
VCI Render Mode 1 (basic)	Select the desired Render Modes.
VCI Render Mode 2 (mix)	
Gray Transparency	Adjust the gray transparency.
B-Mode Quality	Adjust the reverberation suppression.

Using OmniView

1. Press **2D** on the user interface to start B-Mode.
2. Press **4D** on the user interface.
3. The 4Dpre menu appears (with last used acquisition mode).
4. Touch **OmniView** if not already active.
5. The OmniView pre menu appears.
 - 5.1. If "Show VCI-C Line when invoking OmniView" is checked in the System Setup a completed line is displayed - continue with step 8.
 - 5.2. otherwise a cursor (cross) to enter the OmniView line appears on the screen.
6. Optional: change line method and settings.
7. Draw an OmniView line (with the trackball or **xTouch**).
8. Adjust the line - position and / or - rotation).
9. Optional: change settings.
10. Press **Start** on the trackball or **Freeze** on the user interface.

8.6.3.1 Uterine Classification

Note *Uterine Classification is only available for GYN applications.*

Uterine Classification can be also used for reloaded volumes.

Controls

Uterine Classification	Press Uterine Classification to open the Classification menu.
Note	<i>ESHRE or ASRM classification is possible, depending on the selection in the measure setup.</i>
Note	<i>A selected item is displayed on the Uterine Classification button and added to the Uterus worksheet.</i>

8.6.4 TUI (Tomographic Ultrasound Imaging)

Note *TUI is an option.*

TUI is a new “Visualization” mode for 3D and 4D data sets. The data is presented as slices through the data set, which are parallel to each other. An overview image, which is orthogonal to the parallel slices, shows the parts of the volume, which are displayed in the parallel planes. This method of visualization is consistent with the way other medical systems such as CT or MRI, present the data. The distance between the parallel planes can be adjusted to fit the requirements of the given data set. In addition it is possible to set the number of planes.

The planes and the overview image can also be printed to a DICOM printer, for easier comparison of ultrasound data with CT and/or MRI data.

Possible Acquisition Modes:

- 4D Real Time
- 3D Static
- STIC

TUI Menu

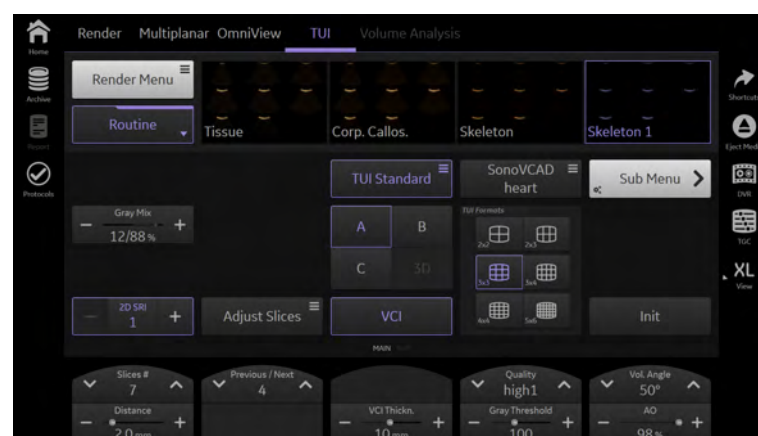

Figure 8-18 Example: TUI Menu

Render Folder	Select the desired render folder.
VCI Thickness	Select the desired thickness (mm).
TUI Standard	Opens the TUI Standard menu.
SonoVCADheart	Opens the SonoVCAD™heart menu.
Render Menu	Opens the Render menu.
VCI	Enable/disable and adjust VCI .
TUI Formats	Select the desired format.
	Note Press the hardkey Single to display 1x1, hardkey Dual to display 1x2 and hardkey Quad to display 2x2.
Ref. Image (A, B, C, 3D)	Select the reference image to which all image dependent functions like parallel shifts, rotations, etc. are applied.
2D:SRI	Applies the filter to the rendered 2D image only.
Adjust Slices	<ul style="list-style-type: none"> • Select a format pattern in which the slices are displayed. • Move the center line. • Change the amount of slices on the left and right of the center line.
Init	Set all translations and rotations back to the initial acquisition position.
Slice #	Select the desired Slice #.
TUI	Opens TUI Mode.
Vol. Angle	Adjust the Volume Angle.

AO	Adjusts the Acoustic Output.
Distance	Displays and adapts the distance.
Tint VCI	Select the desired Tint Map.
Multipanar Image	Select between Filter SRI.
Persist.	Persistence filter for volume cine images.(0 = filter off, range: 1-8)
Probe Orientation	Open the Probe Orientation menu (under More).
Info 2D Param.	Display extended image information in the top right corner (under More).
Smooth	Volume Smoothing. Improve render image quality for high line densities. (only available with VCI)

8.6.5 SonoVCAD™heart

Note SonoVCAD™heart is an option.

SonoVCAD™heart can be used after acquiring a fetal heart data set in either 4D Real Time, 3D Static or STIC. SonoVCAD™heart includes a (semi-auto) mode to adjust the 4CH reference plane and a direct selection of a SonoVCAD™ image via touch button.

Available modes:

- Manual mode: The 4CH reference plane has to be adjusted to the template manually.
- Semi-auto mode (optional): The septum has to be traced manually from apex to crux of the heart with a line. The aorta has to be clicked on by the user. This functions as input for the Auto Alignment. The automatically oriented 4CH reference plane has to be checked for its correctness before **Confirm Alignment** is pressed. If it is not acceptable, it has to be corrected manually and then the SonoVCAD™ has to be started. It is also possible to switch to manual mode.

SonoVCAD™heart can be invoked with the visualization button **TUI** and (if not active) by pressing **SonoVCAD™heart** within the TUI menu. VCI is switched off automatically. To exit SonoVCAD™heart go to another Visualization Mode (the selected reference image and geometry changes are kept).

SonoVCAD™heart Pre Menu

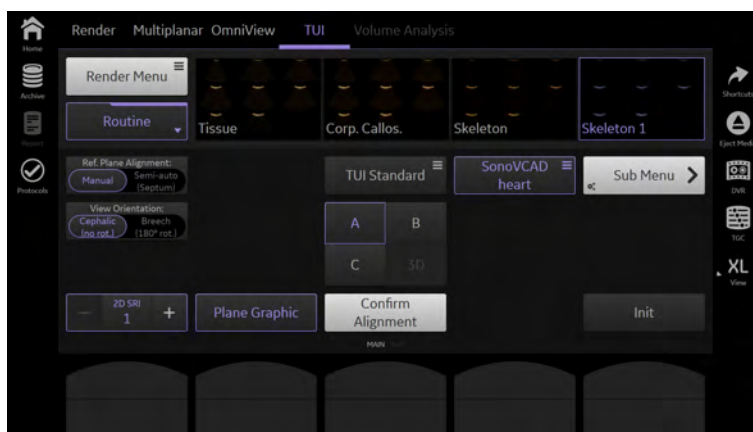

Figure 8-19 SonoVCAD™heart Pre Menu

Ref. Plane Alignment Mode	Select the desired reference plane alignment: Manual or Semi-auto .
View Orientation	Select between Cephalic (displays the Cephalic view without rotation) and Breech (displays the Breech view with 180°rotation).
Ref. Plane Graphic	Displays the heart template on the screen.
2D: SRI	Applies the filter to the rendered 2D image only.

Ref. Image	Select the reference image to which all image dependent functions like parallel shifts, rotations, etc. are applied.
Init	Set all translations and rotations back to the initial acquisition position.
TUI mode	Select between TUI Standard and SonoVCAD™ <i>heart</i> .
Confirm Alignment	Starts the VCAD views. The screen layout changes to the VCAD view (3x3).
Note	<i>If the cursor is moved over a VCAD image, the trackball changes dynamically either to Fullscreen (the selected image is displayed in fullscreen format) or Fullscreen Off (the 3x3 format is displayed).</i>

SonoVCAD™*heart* Main Menu

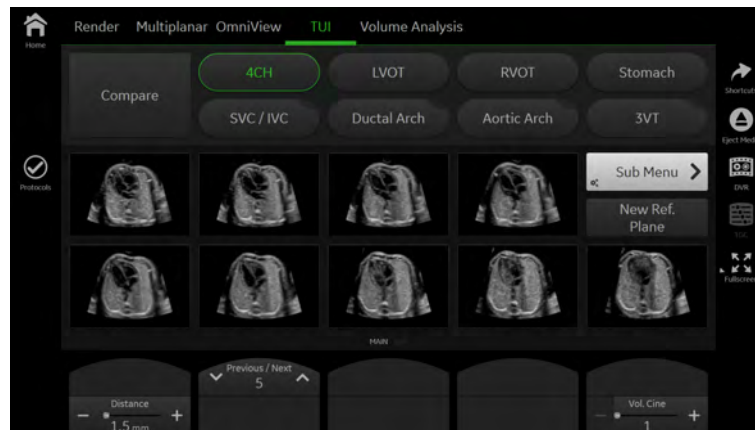

Figure 8-20 SonoVCAD™*heart* Main Menu

Cardiac View buttons	Select the desired Cardiac View (4CH, RVOT, LVOT,...). The availability of these buttons is configurable in the system setup. When Auto Annotate with View Name is selected in the system setup, the Cardiac View name is inserted in the top left corner if the full size image.
New Ref. Plane	Switches back to preMode to adjust a new reference plane.

Using SonoVCAD™*heart*

For using SonoVCAD™*heart* either a STIC, a 3D Static or a 4D Real Time data set has to be available. For automatic use a 4CH view in the A plane is required.

Using Manual mode:

1. Invoke SonoVCAD™*heart*. The preMenu is displayed.
2. Adjust the images A and B according to the superimposed plane graphic with the standard volume controls (i.e. X,Y,Z axis rotation, zoom,...).
3. Press **Confirm Alignment**. The main menu appears displaying the selected Cardiac View (3x3). Select the desired image to be displayed in full size.

Using Semi-auto mode (only if the option is available):

1. Invoke SonoVCAD™*heart* and select **Semi-auto** (if not active). The preMenu is displayed.
2. The message "Draw along the Septum, from Apex to Crux" appears (max. 30 sec). Enter the septum line by defining/positioning a start (apex) and end (crux) point using the cross (displayed in the center of image A). Then the message "Click the Aorta in A-Plane" appears (max. 30 sec). Click onto the aorta. After that the alignment calculation starts automatically.
3. Check whether the displayed alignment is correct. If the result is not correct, adjust the alignment manually.
4. Press **Confirm Alignment**. The main menu appears displaying the selected Cardiac View (3x3). Select the desired image to be displayed in full size.

Note If no 4CH reference plane can be detected in Semi-auto mode, proceed to adjust the septum line/reference plane manually. Switch to Manual mode if necessary.

8.6.6 Niche

Parts of the orthogonal sections A, B and C are compiled to a 3D-section aspect. The name “Niche” has been chosen because the aspect shows a quasi spatial cut into the volume.

Possible Acquisition Modes:

- 4D Real Time
- 3D Static
- STIC

Niche Menu

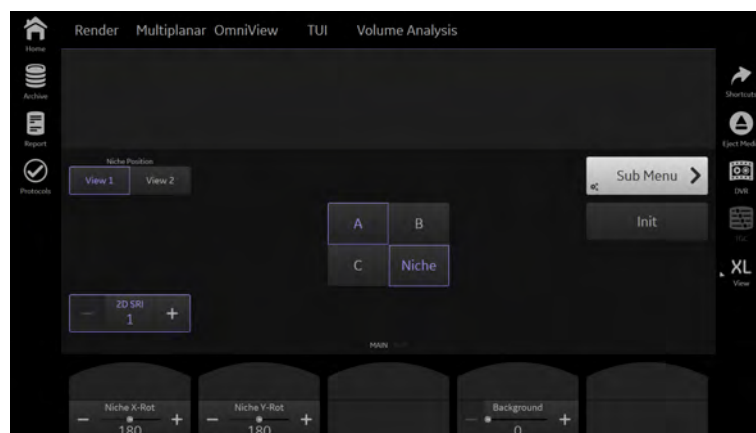

Figure 8-21 Example: Multiplanar Niche

Niche View	Select between 1 and 2 .
2D VSRI	Applies the filter to 2D images.
Niche X-Rot.	Rotate around the X-axis.
Niche Y-Rot.	Rotate around the Y-axis.
Ref. Image	Select the reference image to which all image dependent functions like parallel shifts, rotations, etc. are applied.
Gray/Tint Maps	Select the desired Gray/Tint Map.
Probe Orientation	Displays the Probe Orientation menu.
Info 2D Param.	Displays extended image information in the top right corner.
Orient. Help	Displays the Probe Orientation menu.
Background	Adjusts the level of the background anatomy.

8.6.7 SonoVCAD™labor

Note SonoVCAD™labor is an option.

Note SonoVCAD™labor is available in visualization mode **Multiplanar** only.

This feature allows for supervision of labor using specific measurements aided by on-screen orientation marks. One of the main measurements is the progression angle because the progression angle corresponds directly to the progress of birth. The wider the angle, the more advanced the

delivery is. Multiple measurements can monitor labor progress and contribute to clinical decisions, for example if forceps or vacuum extraction have to be used.

SonoVCAD™ Labor Menu

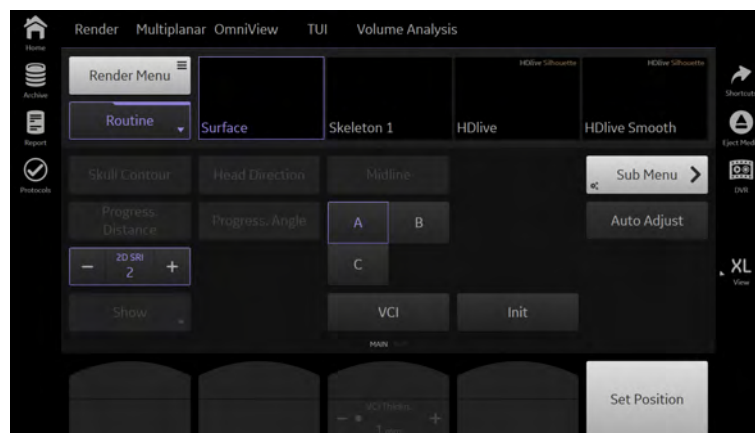

Figure 8-22 SonoVCAD™ Labor pre menu (example)

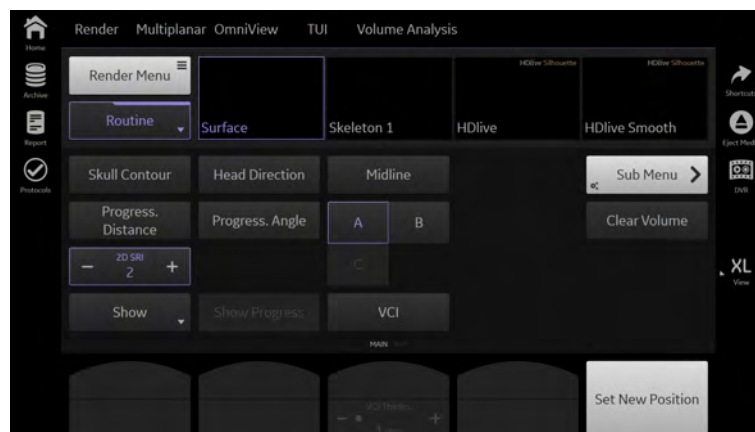

Figure 8-23 SonoVCAD™ Labor main menu (example)

As most controls are the same as in 3D/4D acquisition modes only the SonoVCAD™ Labor relevant controls are described here:

Main Menu / Sub Menu	Select the Main Menu or the Sub Menu .
Set Position	Fixes the position of the data set (used after the data set was successfully aligned to the pubis bone).
Set New Position	Enter a new position of the pubis bone marker.
Auto Adjust	Brings a cursor to mark the position of the pubis bone and auto-rotates the data set into the correct position.
Clear Volume	Deletes all markers of the current acquisition (incl. measurement results) but does not delete manually entered measurements from the worksheet.
Show	Hides/shows a specific type of marker.
Show Progress	Hides/shows the markers from previous acquisitions of the current exam.
Progress Angle	Measures the progression of the fetal head angle. Starting from the center of the pubis, set the end point that the dashed line is tangent to the fetal head. The resulting measurement is the dihedral angle between the pubis and the defined line.
Progress Distance	Measures the progression of the fetal head. The measurement's point of origin is vertically locked to the pubis. Mark the distal point of the fetal head to measure the distance between the pubis and the head in millimeters.
Skull Contour	Set the skull contour by tracing the position of the fetal head point by point.

- Head Direction** Set the head direction by drawing a line of two points along the maximum head diameter. Then mark the most distant point of the head contour. The head direction is automatically calculated as a line orthogonal to the max. diameter passing through the distal point.
- Midline** Set the **Midline** by marking the position of the midline with a line of two points. The measurement result is the calculated angle between the vertical axis and the midline. As the rotation can be to the left or to the right it is necessary to start measuring at the occiput to get accurate results.

8.6.8 VCI-A

VCI-A Main Menu

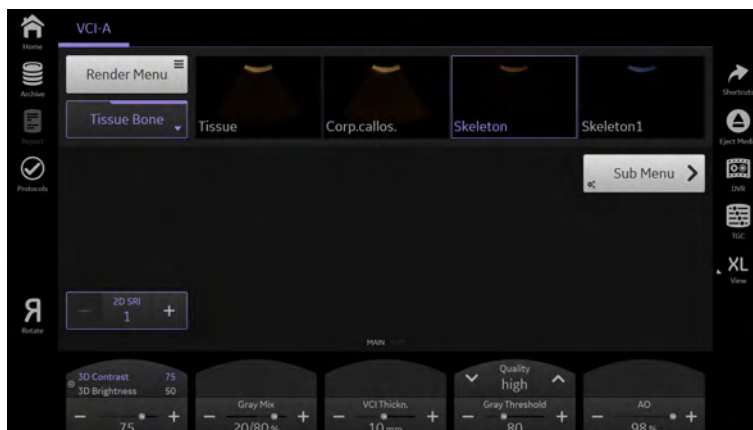

Figure 8-24 VCI-A menu

- VCI Render Presets** Change the preset of the selected render group.
- Rotate** Mirrors the left/right orientation of the VCI-A image.
- 2D:SRI** Applies the filter to the rendered 2D image only.
- 3D Contr.** Adjust the contrast.
- 3D Brightn.** Adjust the brightness.
- Mix** Render mix mode: toggles between the two selected render modes and Gray Threshold low for 3D images.
- Gray thresh.** Displays the Gray Threshold.
- Gray 2D** Select the desired Gray Map.
- Tint 2D** Select the desired Tint Map
- Tint VCI** Select the desired Tint Map.
- 3D Color Off** Turns off color.
- Multplanar Image** Select between Filter SRI.
- Persist.** Persistence filter for volume cine images.(0 = filter off, range: 1-8)
- Info 2D Param.** Display extended image information in the top right corner
- Background** Adjust the background brightness.
- Render Menu** Opens the Render Menu.

Balance	Balance establishes the amount of color displayed over bright echoes and helps confine color within the vessel walls. Raising this balance displays color on brighter structures. If you see color on vessel walls, the balance is probably set too high. Additionally, wall motion ghosting can be suppressed with a low balance setting.
VCI Thickness	Select the desired thickness (mm).

Using VCI-A

1. Press **2D** on the user interface to start B-Mode.
2. Press **4D** on the user interface.
3. The 4Dpre menu appears (with last used acquisition mode).
4. Touch **VCI-A** if not already active.
5. The VCI-A VolPre Menu appears.
6. Change the settings as desired.
7. Press **Start** on the trackball key or **Freeze** on the user interface.

8.6.9 4D Biopsy

- Note** *Real Time 4D Biopsy is an option.*
- Before using biopsy equipment read the safety precautions. For more information see 'Biopsy safety' on page 5-25.*
- Before using 4D Biopsy the biopsy lines must be programmed. For more information see 'Biopsy setup' on page 5-28.*

The intended use of the 4D Biopsy function is to visualize the position of the biopsy needle in a rendered 3D image in real time with the advantage to have a better view of the accuracy to puncture the correct area. For each acquired volume a 3D image is rendered and visualized. So with the 4D volume acquisition – cine of 3D images - the position of the needle can be visualized in real time.

Two biopsy methods are available:

1. Guided biopsy: The guided 4D Biopsy uses the same procedure and method like Guided Biopsy in B-Mode. The only difference is, that the needle is also visualized in a rendered 3D image. Single Angle and Multi Angle biopsy kits are available.
2. Freehand biopsy: The 4D freehand biopsy is included for special use on Small Parts (Breast) with linear volume probes although it is possible with all volume probes on all exam applications.
To use the freehand biopsy the expected freehand needle way is parallel to the probe surface and therefore the render box is automatically displayed with 90° to the probe surface and cannot be rotated by the user. During a biopsy the render box has to be positioned vertically over the needle echoes to see the needle structure also on the 3D rendered image.

Using 4D Biopsy:

1. Activate 4D mode by pressing the **4D** hardkey and then select **4D Biopsy**.
2. Change the biopsy kit if desired.
3. Select the desired biopsy line.
4. Start the acquisition.

4D Biopsy Pre Menu

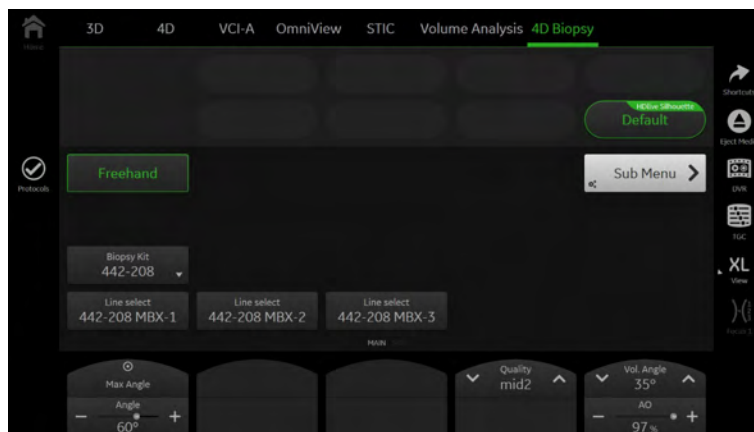

Figure 8-25 4D Biopsy Pre Menu (example)

4D Biopsy Menu

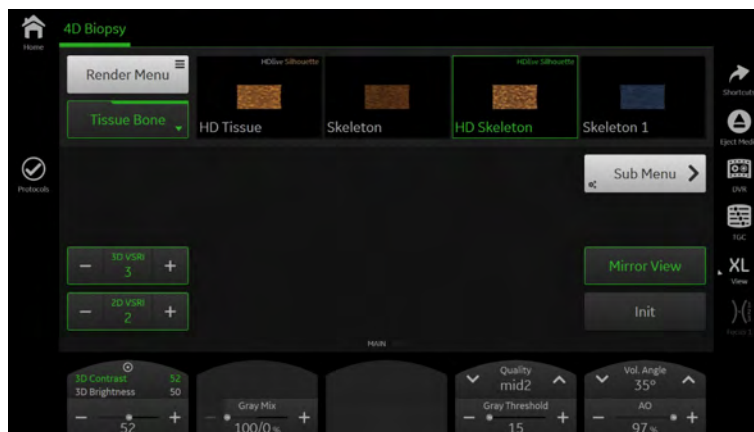

Figure 8-26 4D Biopsy Main Menu (example)

As most controls are the same as in 3D/4D acquisition modes only the 4D Biopsy relevant controls are described here:

- Kit select** Select the desired biopsy kit.
- Line select** Select the desired biopsy line.
- Freehand** Select freehand biopsy.
- Mirror View** Switches the Rendering start (green line) to the opposite side (mirror view).

8.7 Additional tools

8.7.1 Render Modes

Info *The virtual light source of HDlive™ mode can be positioned by keeping the small center trackball button pressed while moving the trackball.*

Info *HDlive™ rendering is not available if Static VCI is active.*

Image rendering

The 3D Image Rendering is a calculation process to visualize certain 3D structures of a scanned volume by means of a 2D image. The gray value for each pixel of the 2D image is calculated from the voxels along the corresponding projection path (analyzing beam) through the volume. The render (calculation) algorithm surface or transparent mode decides which 3D structures are visualized.

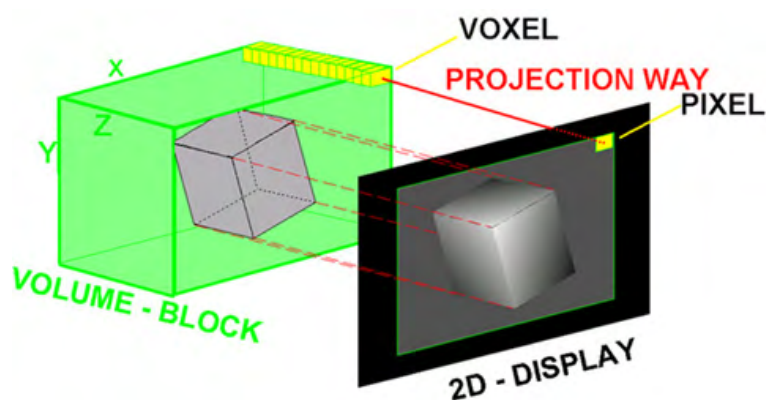

Figure 8-27 Image rendering

Every operation/adjustment concerning the result of the rendering process can be followed in real time. The fast hardware and intelligent software enables calculation in real time rendered pictures. After an operation step the result is rendered with a lower resolution in order to speed up the interactive feedback, and when no further operation takes place the result is rendered in high resolution.

HDlive™

Note *HDlive™ is an option.*

Most current surface reconstructions use an illumination frontal to the rendered object. This can cause the image to look flat. HDlive™ Rendering uses an illumination source that can be positioned by the user around the rendered 3D object on a spherical surface. By highlighting structures from the side, the three-dimensional impression is improved considerably.

HDlive™ Silhouette

Note *HDlive™ Silhouette is an option.*

To improve the impression even more, **Silhouette** (emphasizes the contours of surface structures), **Light Brightness** (adjusts the brightness of the light source) and **Shadow Softness** (varies the shadow softness/contrast) can be adapted.

Gray Silhouette improves B-mode images, **CFM Silhouette** color acquisition images.

Using Render Mode

1. Perform a 3D/4D scan.
2. The **Main** menu appears.

3. Select the render folder.
4. Select the render preset.
5. Optional: Open the Render Menu:
 - 5.1. Select the render type: **Gray**, **Color**, **GlassBody**, **VOCAL Surface** or **Inversion**.
 - 5.2. Select the basic- and mix-Render modes.
Two modes are always active simultaneously. They can be mixed by using the **Mix** rotary control below the touch panel. The last selected mode is fully displayed (100%). Touch the **Mix** control to use 50% of each mode. Rotate the **Mix** control to change the percentage.

8.7.1.1 Render type: Gray & Inversion

Gray Render Mode

In Gray Render Mode only the gray information of the data set is used, even if a Color Volume image is displayed. In case of a data set without color information, this mode is automatically activated.

Inversion Render Mode

This render mode is used to display anechoic structures such as vessels (fluid to solid). This gray render mode inverts the gray values of the rendered image (e.g., image information that was black becomes white and vice versa).

The availability of Inversion Render Mode depends on the selected acquisition mode.

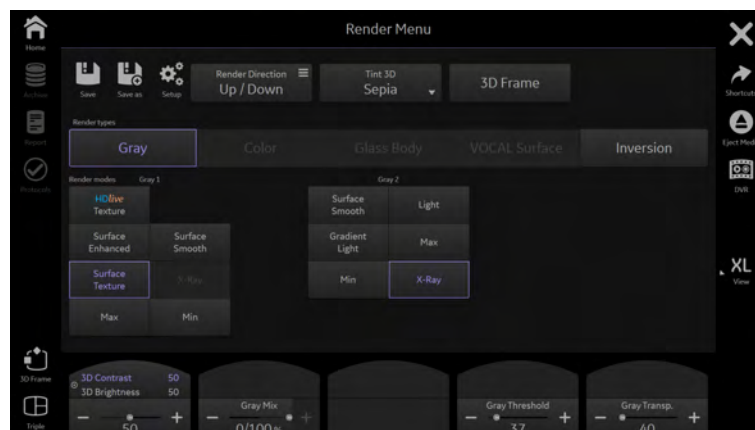

Figure 8-28 Render menu Gray & Inversion

Render Modes

HDlive™	Activates HDlive™.
Surface Smooth	The surface is displayed in a smoothed “texture” mode. The gray values of the surface are identical with the gray values of the original scan.
Surface Texture	A surface will be displayed in “texture” mode. The gray values of the surface are identical with the gray values of the original scan.
Surface Enhanced	Surface display is improved by homogeneous smoothing while retaining details in the image.
Max	The maximum gray values of the ROI are displayed. Application: Representation of bony structures.
Min	The minimum gray values of the ROI are displayed. Application: Representation of vessels and hollow structures.
X-Ray	Representation of the average gray values within the ROI. Application: Tissue block with tumor or similar.

Render Mode 2 (mix)

HDlive™	Activates HDlive™.
Surface Smooth	The surface is displayed in a smoothed “texture” mode. The gray values of the surface are identical with the gray values of the original scan.
Light	A surface will be displayed in “light” mode. Structures close to the viewer are displayed bright; structures more distant from the viewer are shaded. The surface to be displayed has to be surrounded by hypo echoic structures (e.g. liquids).
Gradient Light	The surface will be displayed as if being illuminated from a spot light source. The surface to be displayed has to be surrounded by hypo echoic structures (e.g. liquids).
Max	The maximum gray values of the ROI are displayed. Application: Representation of bony structures.
Min	The minimum gray values of the ROI are displayed. Application: Representation of vessels and hollow structures.
X-Ray	Representation of the average gray values within the ROI. Application: Tissue block with tumor or similar.

Mixed modes

Following combinations of render modes can be mixed.

Render Mode 1 (basic)	Render Mode 2 (mix)						
	HDlive™ Smooth	Surface Smooth	Light	Gradient Light	Max	Min	X-Ray
HDlive™ Texture	X	-	-	-	-	-	-
Surface Smooth	-	-	X	X	X	X	X
Surface Texture	-	X	X	X	X	X	X
Surface Enhanced	-	X	X	X	X	X	X
Max	-	X	-	-	-	X	X
Min	-	X	-	-	X	-	X
X-Ray	-	X	-	-	X	X	-

Table 8-7 Render mixed modes

Touch panel controls

3D Contr.	Adjust the contrast.
3D Brightn.	Adjust the brightness.
Mix	Render mix mode: toggles between the two selected render modes and Gray Threshold low for 3D images.
Gray thresh.	Displays the Gray Threshold.
Transp.	Adjust the transparency.
Light BRT	Adjust the Light BRT .
Shadow	Displays the shadow.
Silhouette	Adjust the Silhouette.

8.7.1.2 Render type: Color

In Color Rendering color information of Color or Power-Doppler signal is used for the 3D display.

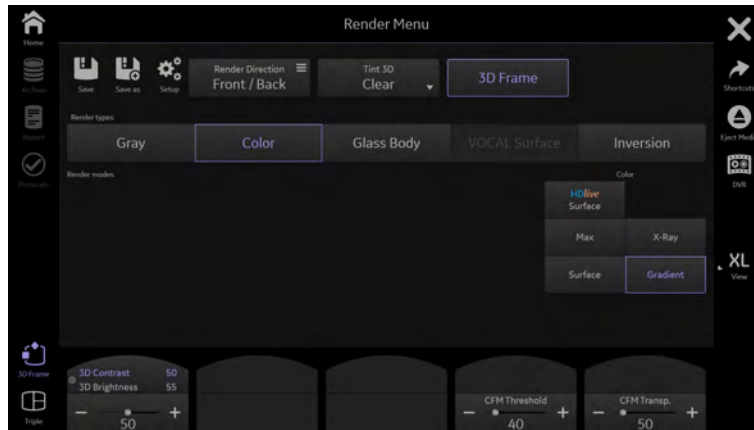

Figure 8-29 **Render menu Color**

Touch panel controls

Color Render

Select the desired mode:

- **HDlive™ Surface**
- **Max**
- **X-Ray**
- **Surface**
- **Gradient**

Rendering Color Map

Select between **CFM** and **Monochrome** (only when HDlive™ Surface is active).

Info

Also see 'Render type: Glassbody' on page 8-40 for more controls described.

8.7.1.3 Render type: Glassbody

In Glassbody render mode the color and the gray information are processed into a 3D/PD, 3D/HD or 3D/CFM volume.

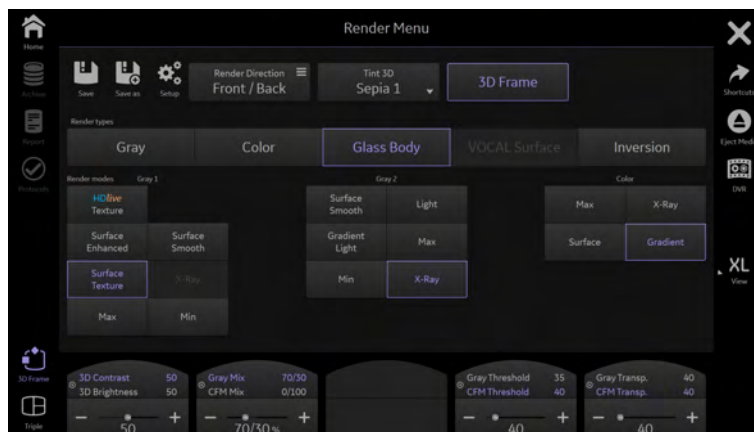

Figure 8-30 **Render menu Glassbody**

Render Modes

Gray Render

Gray Render 1

Select the desired Gray Render 1 mode:

- **Surface Enhanced**
- **Surface Texture**
- **Surface Smooth**
- **X-Ray**
- **Max**
- **Min**
- **HDlive™ Texture**

Gray Render 2

Select the desired Gray Render 2 mode:

- **Surface Smooth**
- **Light**
- **Gradient Light**
- **Max**
- **Min**
- **X-Ray**
- **HDlive™ Smooth**

Color Render

Color Render

Select the desired Color Render mode:

- **HDlive™ Surface**
- **Max**
- **X-Ray**
- **Surface**
- **Gradient**

Mixed Modes

Following combinations of render modes can be mixed.

Gray 1	Gray 2	Color
<i>HDLive™ Texture</i>	<i>HDLive™ Smooth</i>	<i>HDLive™ Surface</i>
<i>Surface Enhanced</i>	<i>Surface Smooth</i> <i>Light</i> <i>Gradient Light</i> <i>Max</i> <i>Min</i> <i>X-Ray</i>	<i>Max</i> <i>X-Ray</i> <i>Surface</i> <i>Gradient</i>
<i>Surface Smooth</i>	<i>Light</i> <i>Gradient Light</i> <i>Max</i> <i>Min</i> <i>X-Ray</i>	<i>Max</i> <i>X-Ray</i> <i>Surface</i> <i>Gradient</i>
<i>Surface Texture</i>	<i>Surface Smooth</i> <i>Light</i> <i>Gradient Light</i> <i>Max</i> <i>Min</i> <i>X-Ray</i>	<i>Max</i> <i>X-Ray</i> <i>Surface</i> <i>Gradient</i>
<i>X-Ray</i>	<i>Surface Smooth</i> <i>Max</i> <i>Min</i>	<i>Max</i> <i>X-Ray</i> <i>Surface</i> <i>Gradient</i>
<i>Max</i>	<i>Surface Smooth</i> <i>Min</i> <i>X-Ray</i>	<i>Max</i> <i>X-Ray</i> <i>Surface</i> <i>Gradient</i>
<i>Min</i>	<i>Surface Smooth</i> <i>Max</i> <i>X-Ray</i>	<i>Max</i> <i>X-Ray</i> <i>Surface</i> <i>Gradient</i>

Table 8-8 Glassbody render mixed modes

Touch panel controls

- CFM Silhouette** Adjust the CFM Silhouette.
- Gray Silhouette** Adjust the Gray Silhouette.
- Mix** Mix Gray Render 1 and Gray Render 2.
- Gray threshold** Adjust the gray threshold.
- CFM Mix** Adjust the CFM mix (Gray Render and Color Render).
- CFM threshold** Adjust the CFM threshold.
- 3D Contrast** Adjust the contrast.
- 3D Brightn.** Adjust the brightness.
- Transp. CFM** Adjust the CFM threshold.

Transp. G.	Adjust the transparency.
Balance	Adjust the Balance (within the More menu).

8.7.1.4 Render Mode: VOCAL Surface

Menu for selecting the VOCAL skin representation.

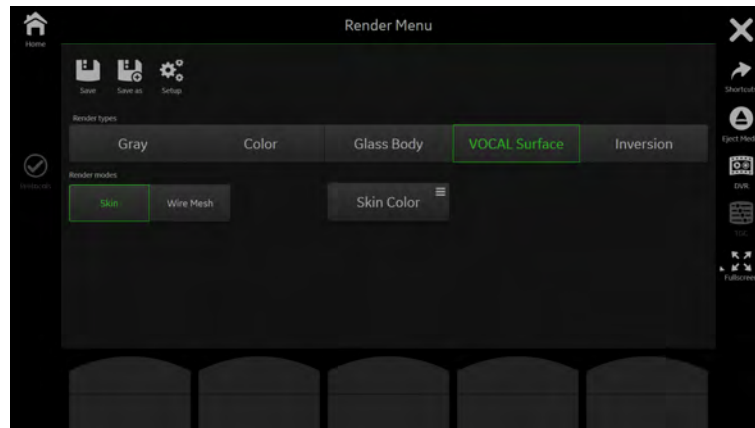

Figure 8-31 Render menu VOCAL Surface

Controls:

Skin	Represents the artificial surface of the structure shaped by the VOCAL trace.
Wire Mesh	Specific shape of the VOCAL structure.
Skin Color	Color of the VOCAL structure representation valid for Skin and Wire Mesh display.

8.7.2 xTouch Edit Light

With the help of the "Edit light menu" the light source position can be changed with the trackball, with the finger or with the preset buttons. The current position is shown by the Light Icon. The preset position can be changed by the user.

It is available only for the following 3D objects:

- HDlive™ Surface object, in run and frozen mode
- 3D Rendered object if the 2nd render mode (mix mode) is "Gradient Light", in run and frozen mode
- VOCAL object
- SonoAVC™ object (follicles)

Edit Light Menu

8 light position presets are available. Press a button to activate the desired preset ("on" is green). This state is switched off if the light position is changed manually.



Figure 8-32 Edit Light Menu

Save Presets

When **Save Presets** is pressed, the popup window "Save preset under" appears. Select a preset to save the current light position. The window closes.

Exit

Press **Exit** to go back to the previous menu.

3D Contr.

Adjust the contrast.

3D Brightn

Light Brightness ranges from 0-100 (step size: 1) and is only available with HD/live™

Mix

Render mix mode: toggles between the two selected render modes and Gray Threshold low for 3D images.

Gray thresh.

Displays the Gray Threshold.

Transp

Adjust the transparency.

Light BRT

Adjust the brightness of the light source (step size:1).

Shadow

Shadow Softness ranges from 0-200 (step size: 5) and is only available with 3D Rendered Images.

Silhouette

Adjust the Silhouette.



Opens a help overlay explaining gestures in **xTouch**.

Possible gestures:



- Move Light: A tap at the US area sets the currently active light to the dedicated position. It is also possible to move the light around the volume (virtual trackball functionality).



Rotates the rendered image freely around the X, Y or Z axis.



Rotate around the Z axis.



Zoom in and out.



Init zoom: a double tap resets the zoom factor to the initial zoom factor.

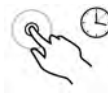

A long press moves the light behind the volume and vice versa (only available when *HDlive™ Silhouette* is activated).

Using Edit Light

1. Press **Edit Light** to open the menu or the Trackball key **Light**.
2. Position the light source with the trackball, with the finger or the preset buttons.
3. Touch **Exit** or press the trackball button **Exit**. The menu closes.

Notes:

A fast access/change of the light position is possible by using the trackball.

Trackball

With a 3D object on the screen, the "Light" function is available on the small left upper button. Press this button to activate it and to position the light source with the trackball. To exit press the small left upper trackball button.

8.7.3 xTouch MagiCut

MagiCut is the ability to edit images and makes it possible to cut structures.

xTouch MagiCut Menu

Cut Mode

Select one of the three possible cut modes.

- **Full:** complete content over the whole depth is cut
- **Defined:** content selected with the depth control is cut
- **Dynamic:** layer by layer is cut

Cut Tools

- **Trace Inside:** content inside the trace will be cut
- **Trace Outside:** content outside the trace will be cut
- **Box Inside:** content inside the Box will be cut
- **Box Outside:** content outside the Box will be cut
- **Small Eraser:** content along the entered trace (small width) will be cut
- **Big Eraser:** content along the entered trace (big width) will be cut

Cut Type

This selection is only available in render mode Glassbody.

- **Gray + Color:** Cut Gray and Color content
- **Gray Only:** Cut Gray content only
- **Color Only:** Cut Color content only

Cut Undo

- **All:** undo all cuts
- **Last:** undo only the last cut

Depth

Adjust the depth.



Opens a help overlay explaining gestures in *xTouch*.

Possible gestures:



Cut



Rotates the rendered image freely around the X, Y or Z axis.



Rotate around the Z axis.



Zoom in and out.



Init zoom: a double tap resets the zoom factor to the initial zoom factor.

Using MagiCut

Trace	Box	Eraser
<ol style="list-style-type: none"> 1. Select Trace Inside or Trace Outside. 2. Use the rotation controls to rotate the rendered 3D image to a position where 3D artifacts or undesired information can be cut. 3. Enter the start point of the trace by positioning the system cursor with the trackball and press Set. 4. Enter the trace with the trackball, the trace is shown with a red line. 5. Enter the end point of the trace by pressing Set. <ul style="list-style-type: none"> ● Cut depth Full: proceed with step 6 ● Cut depth Defined: proceed with step 7 6. The trace closes from end to start point and the cut action is performed. The system cursor appears again to start a new cut. 7. Adjust the wanted depth with the Depth-control. The result of the adjustment is shown in real-time on the 3D image. 8. Press Done to end the cut process. 	<ol style="list-style-type: none"> 1. Select Box Inside or Box Outside. 2. Use the rotation controls to rotate the rendered 3D image to a position where 3D artifacts or undesired information can be cut. 3. Position the left upper point with the trackball and press Set. 4. Move the point with the trackball in a diagonal fashion to create a box. The red trace of the box is displayed immediately. 5. Enter the box by pressing Set. <ul style="list-style-type: none"> ● Cut depth Full: proceed with step 6 ● Cut depth Defined: proceed with step 7 6. The cut action is performed. The system cursor appears again to start a new cut. 7. Adjust the wanted depth with the Depth-control. The result of the adjustment is shown in real-time on the 3D image. 8. Press Done to end the cut process. 	<ol style="list-style-type: none"> 1. Select Small Eraser or Big Eraser. 2. Use the rotation controls to rotate the rendered 3D image to a position where 3D artifacts or undesired information can be cut. 3. Position the first point and press Set. 4. Move the eraser over the part of the image to be erased. The entered trace is shown with a black line in real time. 5. Press the right or left trackball key Set to finish the cut. The region underneath the eraser trace will be cut from the 3D rendered image. The system cursor appears again to start a new cut action

8.7.4 xTouch OmniView

xTouch offers the possibility to work on 3D/4D OmniView mode scans (run and frozen) displayed on the touch panel via intuitive manipulation and gestures.

Note *xTouch* also exists for 3D/4D Render mode scans. Differences (i.e. availability of buttons, sliders,...) exist between both *xTouch* modes.

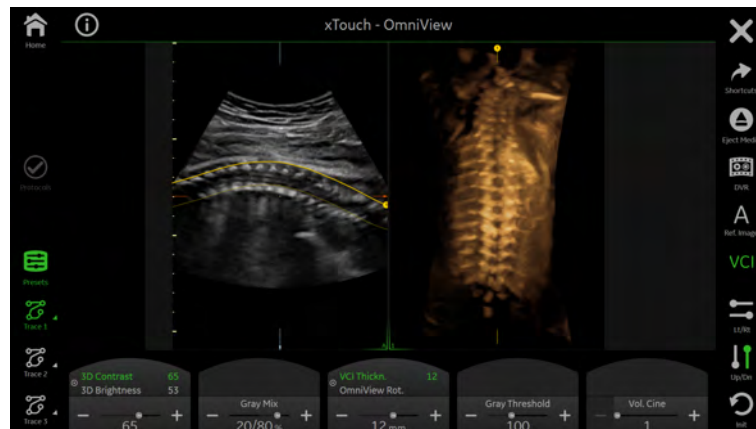

Figure 8-33 *xTouch* OmniView Menu (sample)

xTouch OmniView can be opened either by pressing **Trace with xTouch** in the 4Dpre VCI OmniView menu or by selecting *xTouch* in the 3D/4D menu. As most of the controls are the same as in the normal OmniView menu, only the *xTouch* OmniView relevant controls and gestures are described here:

Possible gestures:



Draw a line:

- Tap and move the finger at the reference image area for drawing a line. Release the finger to set the entered line.
- Tap again at the image to delete the line and to enter a new one.
- The release of the finger in 4Dpre VCI OmniView starts the 4D acquisition.

Select View Port: Tap on the desired view port to select the desired view.



Rotates the reference image freely around the X/Y axis (not available in 4Dpre VCI OmniView).



Rotate around the Z axis (not available in 4Dpre VCI OmniView).







Zoom in and out.

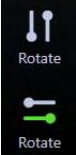
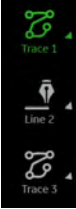

Init zoom: a double tap resets the zoom factor to the initial zoom factor.

Controls:

View	Activates / deactivates the referred line number.
Ref. Image	Open a popup for selecting the reference image.
	Note <i>By switching to another reference image all available OmniView lines are cleared.</i>
Presets	Activates (green) / deactivates the display of available VCI render presets with preview images. The currently selected one is highlighted in green. The preset bar fades out after 3sec of user inactivity.
VCI Thickness	Enables/disables VCI . The currently adjusted thickness is displayed. A long press on the button opens the slider menu for adjusting the thickness. The slider fades out after 3sec of user inactivity.
Clear All	Press Clear All to delete all existing lines.
	Resets the rotations back to the original values.
	Rotates the OmniView planes.
	Select the desired viewport. A long press onto the button opens a popup window for selecting the desired line type (Trace or Line).
	Switches from standard to XL view (green) and vice versa.
	Closes the xTouch menu and returns to the Visualization OmniView or to 4D VCI OmniView pre menu (only available in 4D pre mode).
	Opens a help overlay explaining gestures in xTouch .

8.7.5 Cine Calculation

To get an overall 3D impression of the rendered object a certain number of calculated views are displayed in a sequence. The rendered object rotates or moves in front of the observer.

Note *Not all cine types are available in all visualization modes, see table below.*

Visualization mode	3D Rot. Cine	3D Transl. Cine		3D Slice Cine	
	Full View	Quad View	Full View	Quad View	Full View
Render	X	X	X	-	-
Multiplanar	-	-	-	X	X

Visualization mode	3D Rot. Cine	3D Transl. Cine		3D Slice Cine	
	Full View	Quad View	Full View	Quad View	Full View
SonoAVC™	X	-	-	-	-
VOCAL	X	-	-	-	-

Table 8-9 Cine type availability

3D Rot. Cine

3D rotation cine is the rotation of a volume around either X or Y axis.

Note 3D Rotational Cine is only available in full screen mode.

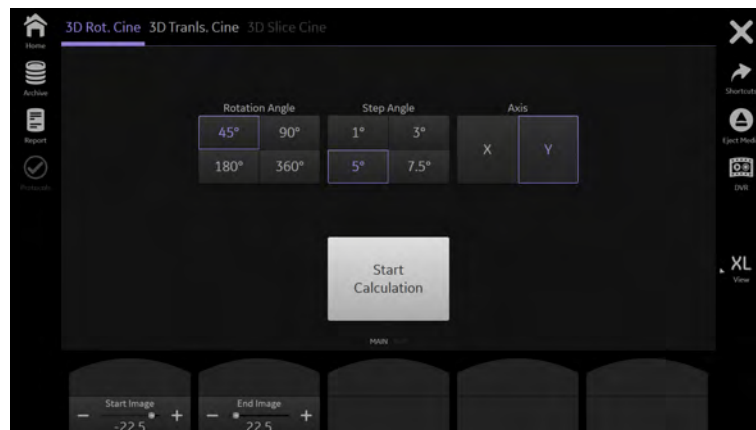

Figure 8-34 3D Rot. Cine Menu

Rotation Angle	Select the desired rotation angle.
Step Size	Select the desired step size.
Axis	Select the desired axis.
Start Calculation	Starts the cine calculation.

1. Select a **Rotation Angle** or use the touch panel controls to adjust the **Start Image** angle and **End Image** angle.
2. Select the **Step Size**.
3. Select the **Rot. Axis**.
4. Touch the **Start Calculation** button.

3D Transl. Cine

A render box is moved in a translational movement through a volume.

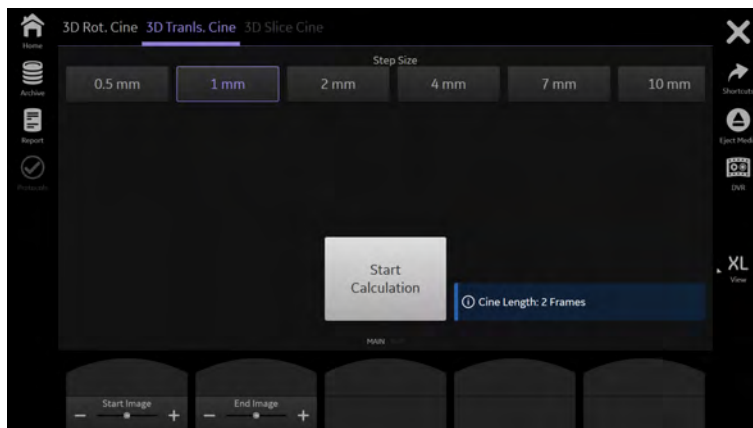

Figure 8-35 3D Transl. Cine Menu

Step Size Select the desired step size.

Start Calculation Starts the cine calculation.

1. Use the touch panel controls to adjust the **Start Image** and **End Image**. When the first image is selected (either **Start Image** or **End Image**) the lines denoting the images will be linked, when you select the second image the lines will be unlinked.
2. Select the **Step Size**.
3. Touch the **Start Calculation** button.

3D Slice Cine

2D images are moved in a translational movement through a volume.

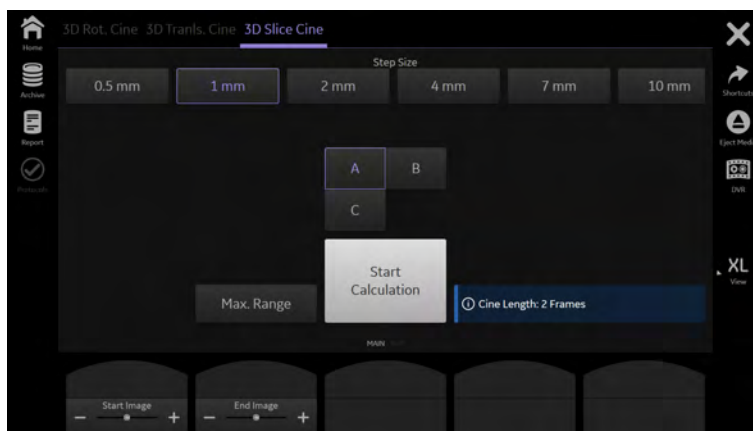

Figure 8-36 3D Slice Cine Menu

Step Size Select the desired step size.

Reference Image Select the desired reference image A, B or C.

Max. Range Sets the frame position to the maximum of the current display format border.

Start Calculation Starts the cine calculation.

1. Use the touch panel controls to adjust the **Start Image** and **End Image**. When the first image is selected (either **Start Image** or **End Image**) the lines denoting the images will be linked, when you select the second image the lines will be unlinked.
2. Select the **Step Size**.
3. Select the desired reference image.

4. Select **Max. Range** to set the **Start Image** and **End Image** as far away from each other as the size of the render box allows.
5. Touch the **Start Calculation** button.

Calculating a cine sequence

Image after image of the sequence is calculated and stored in the cine memory. After the calculation is finished the cine sequence is displayed on the screen.

Touching the **Stop Calculation** button stops the cine calculation. The images calculated before the calculation is stopped are displayed as a sequence.

Cine replay menu

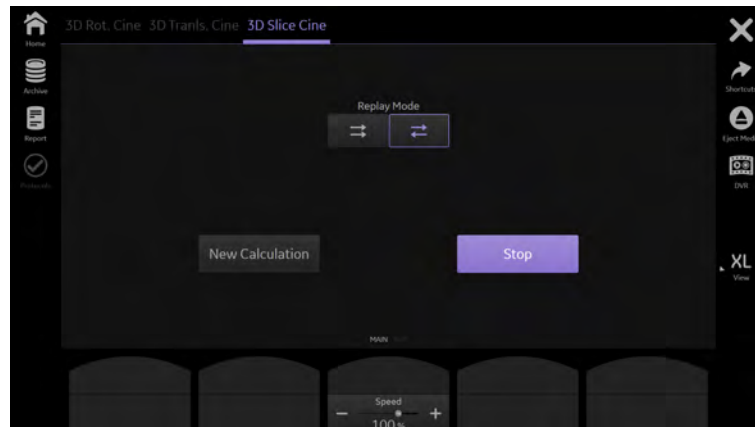

Figure 8-37 Cine replay menu (example)

Replay mode	Replay the sequence from start to end or from start to end and backwards.
Start / Stop	Start or Stop the playback.
New Calculation	Invoke a new calculation.

1. Calculate a cine sequence.
2. The cine replay menu appears.
3. Select a **Replay mode**.
4. Use the touch panel control to adjust the **Speed** of the playback.
5. Touch **Start/Stop** to toggle between playback and stop.

8.7.6 Speckle Reduction Imaging (SRI)

Speckle Reduction Imaging (SRI) can be activated to reduce speckle.

Note *If selected in System Setup - User Settings, SRI affects slices and rendered image. Therefore, it is also active in Full Screen mode.*

In addition, if SRI is activated in 2D mode, it is automatically activated in 3D/4D VolPre mode and automatically affects the image after/during acquisition.

Activate SRI and change the level of smoothing in the sectional planes using the - + keys on the touch panel. Use of SRI is indicated in the info block.

8.7.7 Volume Analysis

8.7.7.1 VOCAL II

Note Read 'Operation safety' on page 2-21 before using this feature.

VOCAL - Imaging program opens up completely new possibilities in cancer diagnosis, therapy planning and follow-up therapy control. It offers different functions:

- Manual or Semi automatic Contour detection of structures (such as tumor lesion, cyst, prostate, etc.) and subsequent volume calculation. The accuracy of the process can be visually controlled by the examiner in multi-planar display.
- Construction of a virtual shell around the contour of the lesion. The wall thickness of the shell can be defined. The shell can be imagined as a layer of tissue around the lesion, where the tumor vascularization takes place.
- Automatic calculation of the vascularization within the shell by 3D color histogram by comparing the number of color voxels to the number of gray scale voxels.

The follow-up control of tumor volume and vascularization delivers information on the proper dose of medication or radiation and is therefore a measure for the success of treatment. After definition of a contour in 3D space a wide range of functionality is given:

- definition of a shell contour
- visualization of a (shell) contour as a surface or wire mesh
- volume calculation of a (shell) contour
- histogram calculation of ultrasound tissue inside a (shell) contour
- visualization of ultrasound tissue inside a (shell) contour as a rendered image
- niche presentation of contour and slices
- cine rotation calculation

The basic idea behind VOCAL is the combination of 3D ultrasound tissue (presented as voxels) and the geometric information of surfaces in a 3D data set. The main interest of VOCAL is the volume calculation of tumors or lesions.

Volume Analysis Menu: VOCAL

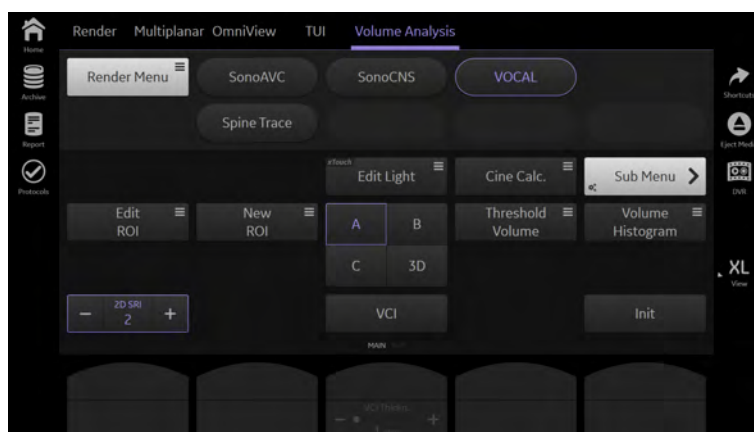

Figure 8-38 Volume Analysis Menu: VOCAL pre menu (example)

Manual Trace

This function allows you to manually outline any lesion by means of the trackball. Alternatively, trace the object on the touch panel with your finger. The number of manually generated contours depends on the selected rotation step.

Trace Finder

This function allows you to outline any lesion by tracing the object on the touch panel with your finger. The number of the semi automatic generated contours depends on the selected rotation step.

Semi-auto Trace Finder	Compared to Trace Finder , only 2 planes (one at the initial position, the other one at 90° rotation) have to be traced. The boundary of the ROI at all other rotation steps is found by means of the contour detection algorithm via automatic interpolation. We recommend to select 9° or 15° rotation step.
Sphere	This computer assisted function is useful if you want to outline the surface of a sphere. Using this function a sphere round the main contour axis is generated within the two green arrows.
Type of structure	Only available with Semi-auto Trace Finder . <ul style="list-style-type: none"> ● Cystic: Typically for all fluid filled structures like gallbladder, urinary bladder, cysts, etc. ● Hypo: Typically for hypo-echoic lesions, breast tumors, irregular shaped internal structures not surrounded by fluid. ● Hyper/Iso: Typically for solid lesions and structures such as uterus, endometrium, kidney, prostate, thyroid, fibroadenoma, lymph nodes, etc.
Rotation Steps	Defines how many contours have to be generated. The decision, which rotation step should be chosen depends on the shape of the ROI. For example: An angle setting of 30° means that after the first trace has been done, the volume data set is rotated 30° and then the next trace has to be performed, and so on. With rotation step 30° , 6 traces have to be done (6° = 30, 9° = 20, 15° = 12 and 30° = 6 traces). For symmetrical, roundish structures a 30° rotation step is fine for all generation modes. For irregular shapes, select 15° for Manual Trace and Trace Finder , and 9° for Semi-auto Trace Finder .
Ref. Image	Select the reference image to which all image dependent functions like parallel shifts, rotations, etc. are applied.
Start VOCAL	Start the volume calculation.

Note**Guidance and precautions for using VOCAL Contour Finder:**

- *The accuracy of the VOCAL volume calculation is dependent on the accuracy of every single VOCAL boundary.*
- *The resulting VOCAL trace must be reviewed and checked by comparing the actual US image on the monitor to the boundaries displayed in each rotation slice.*
- ***Only** the US image on the monitor may be used for diagnostic purposes. The US Image on the touch panel is considered a part of the user interface only. The image on the touch panel is **not** in any way suited for diagnostic purposes.*

Note

- ***Semi-auto Trace Finder** is faster than the **Trace Finder** method but less accurate. The resulting VOCAL trace has to be reviewed with extreme care.*
- *If the **Trace Finder** modes do not lead to satisfying results, use **Manual Trace** to create the VOCAL trace.*

VOCAL Menu

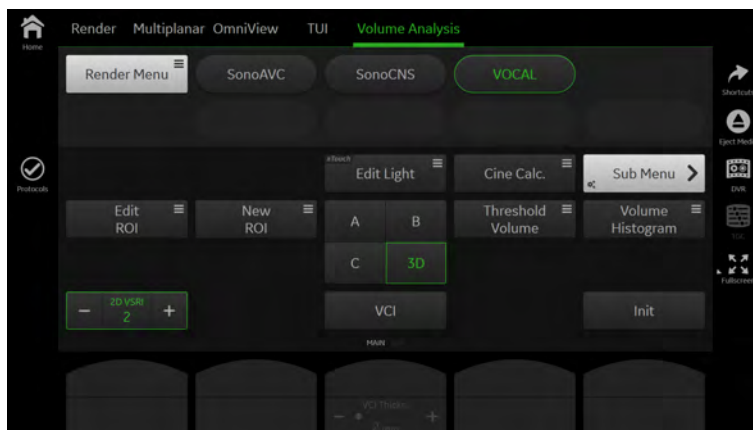

Figure 8-39 VOCAL Main Menu (example)

Edit ROI	Edit the existing ROI.
New ROI	Select an new ROI.
VCI	Enable/disable and adjust VCI .
Main / Sub Menu	Opens the Main or Sub Menu .
VCI Thickness	Select the desired thickness (mm).
2D: SRI	Applies the filter to the rendered 2D image only.
Threshold Volume	Displays the calculated Threshold Volume (according to the monitor display). Adjust the Threshold Volume by using the touch panel control. A small number cuts off fewer signals than a higher number.
Volume Histogram	Displays the calculated Volume Histogram . The Volume Histogram is calculated from the defined volume.
Init	Set all translations and rotations back to the initial acquisition position.
Ref. Image	Select the reference image to which all image dependent functions like parallel shifts, rotations, etc. are applied.

8.7.7.2 SonoAVC™follicle

- Note** *SonoAVC™follicle is an option.*
- Note** *If a 4D Volume cine is present, the system will automatically switch to 3D Static when SonoAVC™follicle is pressed.*
- Note** *Render mode Inversion is activated automatically.*

This feature helps to detect low echogenic objects (eg. follicles) in an organ (eg. ovary) and analyzes their shape and volume. From the calculated volume of the object an average diameter will be calculated.

The calculation results are displayed in the right monitor area. The order of the follicle list depends on the chosen method:

- **auto, semi auto:** measured follicles are ordered by the value $d(v)$ descending
- **manual:** follicles are sorted in the order in which they were measured

All different objects are color coded i.e. the color surrounding the number of the object also denotes the object on the image. If the mouse cursor hovers over a specific item on the list the respective object in the image is highlighted and vice versa. The color of the object is bound to its position on the list.

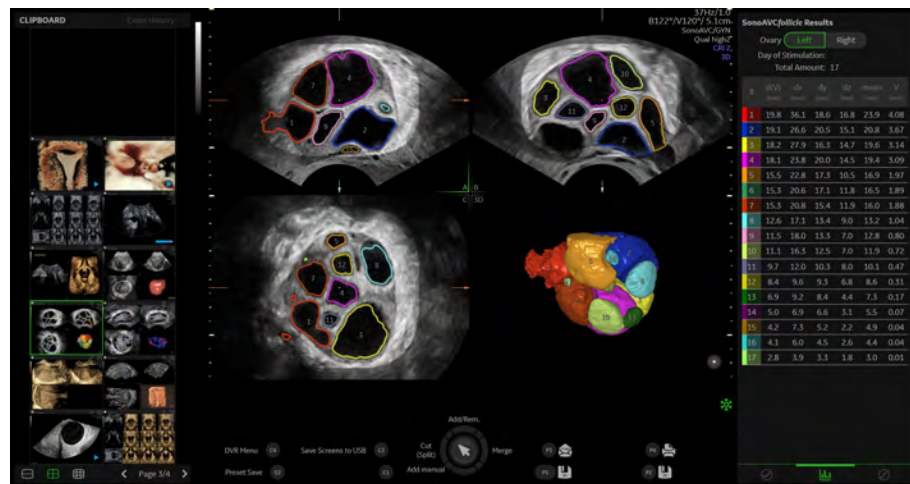

Figure 8-40 SonoAVC™follicle screen display

d(V)	Diameter, calculated as if the object were a perfect sphere
dx	Length of x-axis of the best fitting ellipsoid
dy	Length of y-axis of the best fitting ellipsoid
dz	Length of z-axis of the best fitting ellipsoid
mean d	Average value of the x-axis, y-axis and z-axis
V	Volume of the object

Volume Analysis Menu: SonoAVC™follicle

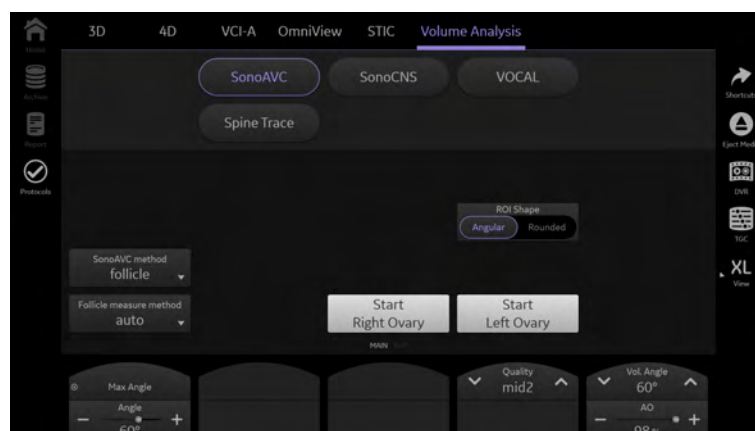

Figure 8-41 Volume Analysis Menu: SonoAVC™follicle pre menu (example)

ROI shape

Select the desired ROI shape:

- **angular**: the box has the shape of a rectangle
- **rounded**: the box has an elliptical shape with rounded corners that can be adjusted by pressing (default position) and rotating (rounding the corners) the rotary control. It is embedded in a rectangular box.

Follicle Measurement Method

Select one of the following methods:

- **manual**: Each follicle has to be selected and measured manually.

Note It is possible to perform the double caliper measurements by an AI algorithm.

- **semi auto**: Each follicle is selected manually with the system cursor but traced / measured automatically.
- **auto**: The follicles are detected automatically.

Start SonoAVC™

Select **Start Left Ovary** or **Start Right Ovary** to start SonoAVC™.

Ref. Image

Select the reference image to which all image dependent functions like parallel shifts, rotations, etc. are applied.

SonoAVC™follicle Menu

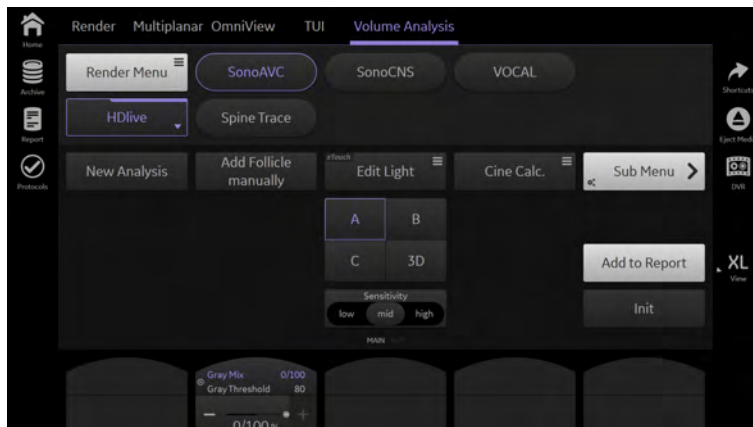

Figure 8-42 SonoAVC™follicle Menu (example)

New Analysis

Starts a new analysis.

Add Follicle manually

Only available when **auto** or **semi-auto** is selected. Not detected or wrong detected follicles may be added.

Edit Light

The Light source position can be changed with the trackball to any position or with the preset buttons to dedicated positions. The current position is shown with help of the Light Icon.

Main / Sub Menu

Opens the **Main** or **Sub Menu**.

Calc Cine

Displays the Cine Calculations menu.

Add to Report

Adds the data to the report.

Cut/Merge

- **Undo All:** Undo all edits.
- **Redo:** Redo the last edit.
- **Undo:** Undo the last edit.

Ref. Image

Select the reference image to which all image dependent functions like parallel shifts, rotations, etc. are applied.

Init

Set all translations and rotations back to the initial acquisition position.

Separation

Separation controls a parameter that defines an initial threshold to separate objects. An increase of the parameter prevents objects from being identified as multiple objects but might also prevent small objects from being found correctly.

Growth

Growth defines the final shape of the objects found. An increase of the parameter allows the objects to fit tighter into the visible boundary. A value too large can cause the objects to grow over the boundary and cover areas no longer part of the objects of interest. (only available for **auto** and **semi-auto** mode)

Using SonoAVC™follicle

Follicle Measurement Method: **manual**

1. Scan and freeze or reload a follicle volume data set.
2. Switch sect. plane A to full size if not present.
3. Adjust the sect. plane A with x, y, z rotation, parallel shift and zoom to achieve the correct measuring plane.
4. Touch **Volume Analysis** and select SonoAVC™follicle.

5. Select **manual** and adjust the ROI shape if desired.
 6. Start the measurement by touching either **Left Ovary** or **Right Ovary**.
 7. The green measurement cross appears in the middle of the image.
 8. Select the desired measurement tool.
 - Ellipse
 - 8.1.1. Position the start-point of the long diameter with the Trackball and press **Set**.
 - 8.1.2. Position end-point of the long diameter with the Trackball and press **Set**.
 - 8.1.3. If desired press **Change** to adjust the start- and end-point.
 - 8.1.4. Adjust the short diameter with the Trackball press **Set**.
 - 8.1.5. To start the next measurement move the Trackball and continue with step 1.
 - Double Caliper
 - 8.2.1. Position the start-point of the long diameter with the Trackball and press **Set**.
 - 8.2.2. Position end-point of the long diameter with the Trackball and press **Set**.
 - 8.2.3. If desired press **Change** to adjust the start- and end-point.
 - 8.2.4. Move the Trackball and so the green measurement cross appears.
 - 8.2.5. Position the start-point of the short diameter with the Trackball and press **Set**.
 - 8.2.6. Position end-point of the short diameter with the Trackball and press **Set**.
 - 8.2.7. To start the next measurement move the Trackball and continue with step 1.
 - **Auto Caliper** (automatic workflow)
 - 8.1.1. Press **Auto Caliper** on the trackball and position the cursor or use xTouch over the desired follicle structure.
 - 8.1.2. Press the left or right trackball key or use **xTouch** to start the **Auto Caliper**. An AI algorithm is activated to detect the follicle structure.
 - 8.1.3. If a follicle structure is found, a double caliper measurement is performed and completed automatically. The result is added to the SonoAVC™ follicle **Results** list.
 - 8.1.4. If no valid follicle structure is found, Auto Caliper is deactivated. It is possible to perform the measurement manually.
 9. Is the measurement finished?
 - no: adjust the sect. plane A with parallel shift to achieve the next wanted measurement slice position and continue with step 8.
 - yes: continue with next step
 10. Select **Add to Report** to save the measurements to the current exam.
- Follicle Measurement Method: *semi auto***
1. Scan and freeze a follicle volume data set.
 2. Touch **Volume Analysis** and select SonoAVC™ follicle.
 3. Select **semi auto**.
 4. Start the measurement by touching either **Left Ovary** or **Right Ovary**.
 5. Measure all wanted follicles on the current plane.
 - 5.1. Position the system cursor over the follicle to be measured and press **Add/Rem**.
 - 5.2. If selected in the main menu, the found trace with it's corresponding color and number is displayed.

- 5.3. Position the system cursor over the next follicle to be measured and press **Add/Rem.**
6. Is the measurement finished?
 - no: adjust the sect. plane A with parallel shift to achieve the next wanted measurement slice position and continue with step 5.
 - yes: continue with next step

7. Select **Add to Report** to save the measurements to the current exam.

Follicle Measurement Method: *auto*

1. Scan and freeze a follicle volume data set.
2. Touch **Volume Analysis** and select SonoAVC™*follicle*.
3. Adjust the ROI.
4. Select **auto** and adjust the ROI shape if desired.
5. Start the measurement by touching either **Left Ovary** or **Right Ovary**.
6. The rendered follicles and the result list are displayed on screen.
7. Edit the results if necessary.
8. Select **Add to Report** to save the measurements to the current exam.

Add Follicle manual:

1. Touch **Add Follicle manual**.
2. The measurement cross appears in the middle of the sect. plane A.
3. Select the desired measurement tool.
 - Ellipse
 - 3.1.1. Position the start-point of the long diameter with the Trackball and press **Set**.
 - 3.1.2. Position end-point of the long diameter with the Trackball and press **Set**.
 - 3.1.3. If desired press **Change** to adjust the start- and end-point.
 - 3.1.4. Adjust the short diameter with the Trackball press **Set**.
 - 3.1.5. To start the next measurement move the Trackball and continue with step 1.
 - Double Caliper
 - 3.1.1. Position the start-point of the long diameter with the Trackball and press **Set**.
 - 3.1.2. Position end-point of the long diameter with the Trackball and press **Set**.
 - 3.1.3. If desired press **Change** to adjust the start- and end-point.
 - 3.1.4. Move the Trackball and so the green measurement cross appears.
 - 3.1.5. Position the start-point of the short diameter with the Trackball and press **Set**.
 - 3.1.6. Position end-point of the short diameter with the Trackball and press **Set**.
 - 3.1.7. To start the next measurement move the Trackball and continue with step 1.
4. Close the **Add Follicle manual** menu.

8.7.7.3 SonoAVC™*antral 2.0*

Note *SonoAVC™antral 2.0 is an option.*

Note *If a 4D Volume cine is present, the system will automatically switch to 3D Static when SonoAVC™antral 2.0 is pressed.*

"Antral" means "antral follicle count". SonoAVC™*antral 2.0* enables to automatically detect and count antral follicles within a ROI box in a 3D volume data set.

Volume Analysis Menu: SonoAVC™*antral* 2.0

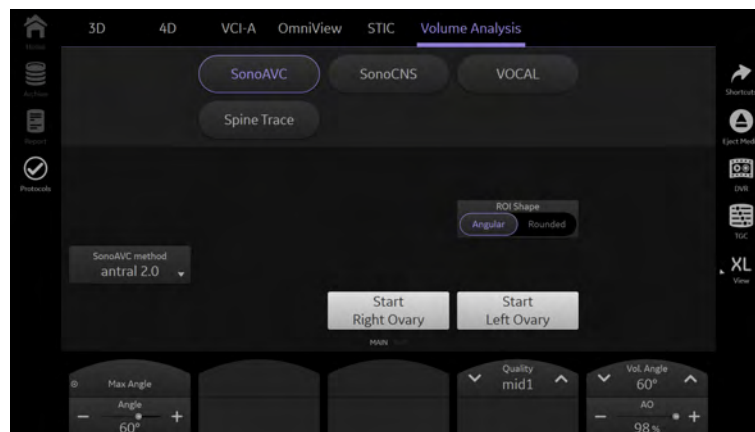

Figure 8-43 Volume Analysis Menu: SonoAVC™*antral* 2.0 pre menu (example)

ROI shape

Select the desired ROI shape:

- **angular**: the box has the shape of a rectangle
- **rounded**: the box has an elliptic shape with rounded corners that can be adjusted by pressing (default position) and rotating (rounding the corners) the rotary control. It is embedded in a rectangular box.

Reference image

Select the desired reference image.

Start SonoAVC™

Select **Left Ovary** or **Right Ovary** to start SonoAVC™.

SonoAVC™*antral* 2.0 Menu (example)

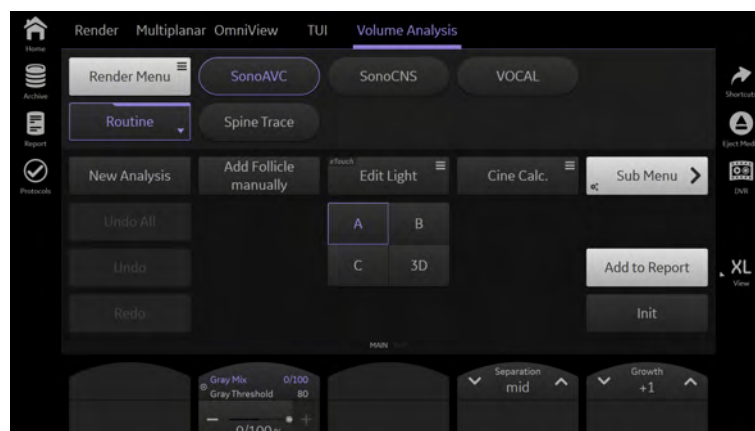

Figure 8-44 SonoAVC™*antral* 2.0 menu (example)

New Analysis

Starts a new analysis.

Add Follicle manually

Not detected or wrong detected follicles may be added.

Main / Sub Menu

Opens the **Main** or **Sub Menu**.

3D Brightness

Adjust the brightness as desired.

3D Contrast

Adjust the contrast as desired.

Gray Threshold

Adjust the threshold as desired.

Mix

Adjust the values as desired.

Add to Report

Adds the data to the report.

Ref. Image

Select the reference image to which all image dependent functions like parallel shifts, rotations, etc. are applied.

Init

Set all translations and rotations back to the initial acquisition position.

Result Display

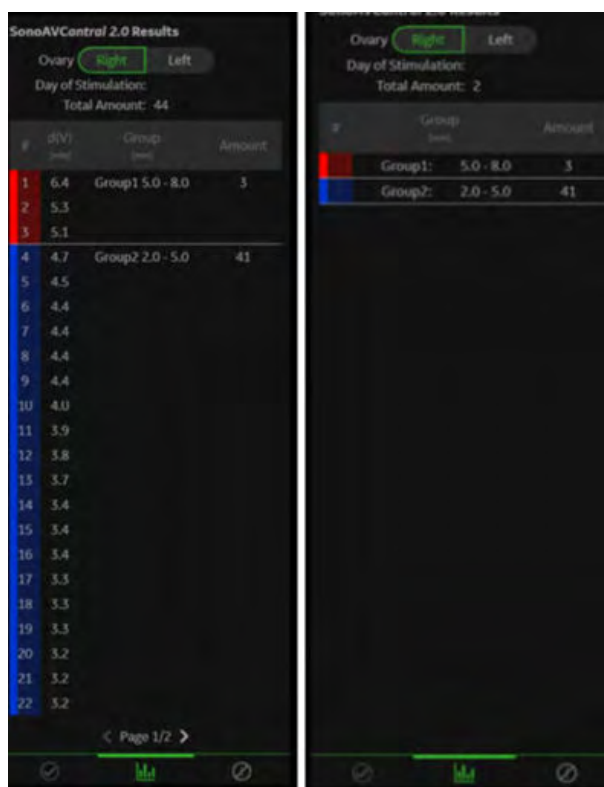

Figure 8-45 Result Display

The calculation results are displayed in the right monitor area. The objects are listed according to groups defined. Only the follicles belonging to the specified group (i.e. 2-4mm,...) are displayed. The Total Amount number displays all follicles which belong to a group. All different groups are color coded i.e. the color surrounding the number of the object also denotes the object on the image. If the mouse cursor hovers over a specific item on the list the respective object in the image is highlighted and vice versa. The color of the object is bound to its group position on the list. By pressing **Number** the display mode can be changed from standard (Fig.1, all defined groups are listed) to extended (Fig.2, all detected follicles within a group are listed).

Using SonoAVC™antral 2.0

1. Scan and freeze or reload a follicle volume data set.
2. Touch **Volume Analysis** and select SonoAVC™antral 2.0.
3. Adjust the ROI shape if desired.
4. Start the antral follicle segmentation by touching either **Left Ovary** or **Right Ovary**.
5. The rendered follicles and the result list are displayed on screen.
6. Edit the results if necessary.
7. Select **Add to Report** to save the measurements to the current exam.

8.7.7.4 SonoAVC™general

Note SonoAVC™general is an option.

Note If a 4D Volume cine is present, the system will automatically switch to 3D Static when SonoAVC™general is pressed.

In SonoAVC™general low echogenic objects in an organ (e.g. ovary) can be defined and named by the user. User defined will show up in the patients report with the defined name.

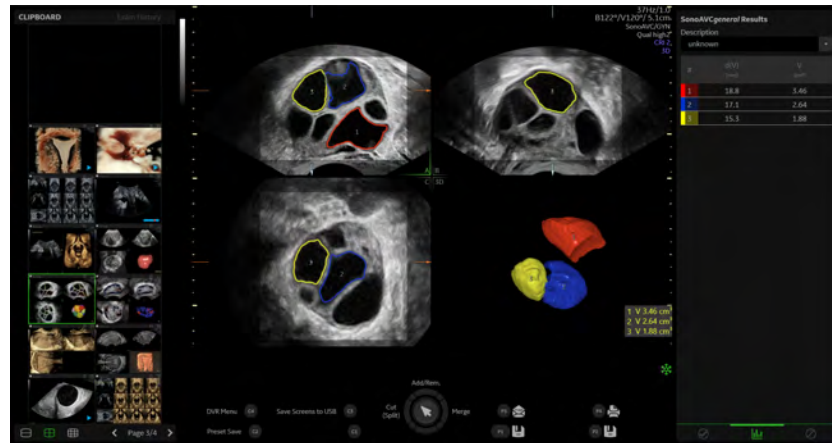

Figure 8-46 SonoAVC™ general screen display

Volume Analysis Menu: SonoAVC™ general

Ref. Image	Select the reference image to which all image dependent functions like parallel shifts, rotations, etc. are applied.
Start SonoAVC™	Starts SonoAVC™.

SonoAVC™ general Menu

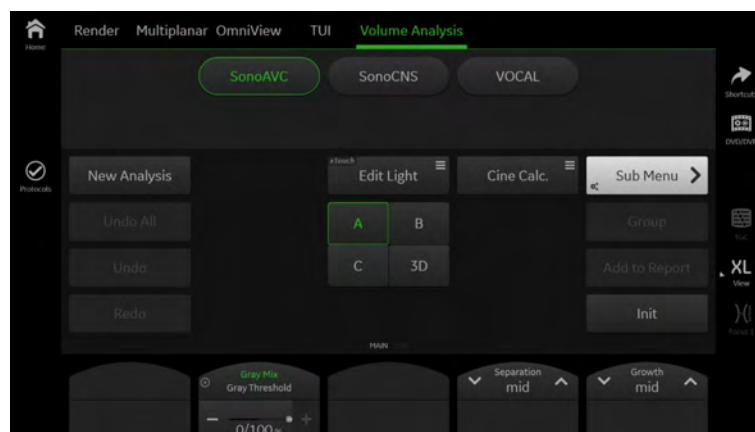

Figure 8-48 SonoAVC™ general Menu (example)

New Analysis	Starts a new analysis.
Add Follicle manually	Not detected or wrong detected follicles may be added.
Edit Light	The Light source position can be changed with the trackball to any position or with the preset buttons to dedicated positions. The current position is shown with help of the Light Icon.
Main / Sub Menu	Opens the Main or Sub Menu .
Edit Light	Displays the Edit Light menu.
Calc Cine	Displays the Cine Calculations menu.
Add to Report	Adds the data to the report.

Group	<p>Toggle between on and off .</p> <ul style="list-style-type: none"> ● on: All objects will be added to one volume. The color of all Objects will be changed to red and measurement will show only one result. ● off (default): All Objects will be displayed in different colors and measurement show one result for every object.
Cut/Merge	<ul style="list-style-type: none"> ● Undo All: Undo all edits. ● Redo: Redo the last edit. ● Undo: Undo the last edit.
Ref. Image	Select the reference image to which all image dependent functions like parallel shifts, rotations, etc. are applied.
Init	Set all translations and rotations back to the initial acquisition position.

Using SonoAVC™*general*

1. Scan and freeze a follicle volume data set.
2. Touch **Volume Analysis** and select SonoAVC™*general*.
3. Adjust the ROI.
4. Start the measurement by touching **Start SonoAVC™**.
5. Position the system cursor over the object to be calculated and press **Add/Rem..**
6. Is the measurement finished?
 - no: repeat step 5 for the next object.
 - yes: continue with next step
7. If desired, use the pull down control in the right monitor area to enter a name of the segmented object.
8. Select **Add to Report** to save the measurements to the current exam.

8.7.7.5 SonoCNS



Caution

SonoCNS is intended for use with gestational ages between 18 and 25 weeks only.

Note *SonoCNS is an option.*

Note *SonoCNS is available for 3D pre, 3D or 4D write or with a reload of a 3D/4D dataset. Switching to another tool or visualization type deletes all SonoCNS alignments and measurements.*

SonoCNS is a method to examine the fetal Central Nervous System (CNS) based on acquired 3D/4D ultrasound volumes. The tool provides the user with:

1. A view of the TV (Transventricular), TC (Transcerebellar), TT (Transthalamic) and MS (Mid-sagittal) plane.
2. Up to six measurements (after the four views were accepted): HC (head circumference), BPD (bi-parietal diameter), OFD (occipito-frontal diameter), CEREB (cerebellum), CM (cisterna magna), Vp (posterior ventricle).

The required volume can be newly acquired, re-loaded from the archive, or extracted from a 4D cine.

Note that the volume has to be acquired starting from the trans-thalamic plane and contain the entire fetal head and the fetal head should take up the majority of the space inside the volume. Ensure the correct placement of all selected planes (Trans-thalamic, -ventricular, -cerebellar, and mid-sagittal planes) before selecting **Start Measurements**.

If no MSP or TTP is found by the SonoCNS algorithm, a message appears.

SonoCNS menu (example)

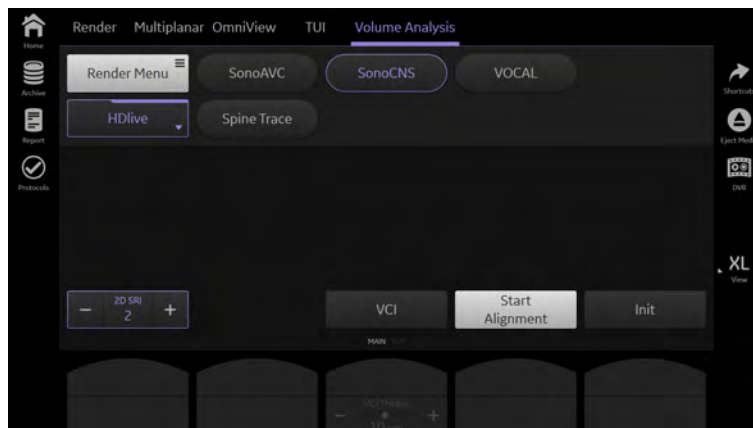

Figure 8-49 SonoCNS menu (example)

All controls are the same as in 3D4D mode. Therefore only the SonoCNS relevant controls are described here:

Start / Start Alignment	Press Start / Start Alignment to start the SonoCNS alignment. While SonoCNS is calculating, a progress indicator appears.
Plane selection	Select the desired plane (TC, TT or TV).
Start Measurements	Press Start Measurements to start the SonoCNS measurements.
Edit Measurement	Select the desired measurements (CM, BPD, HC,...) for editing.
TC, TT, TV	Select the desired menu button on the touch panel to see the selected planes in single mode. Go back with the quad mode hardkey to see all planes at once.
Add to Report	Press Add to Report to transfer the measurements to the worksheet.
Manual Alignment	Select Manual Alignment to return to do a new manual alignment. All measurements are cleared.
Init	Select Init to return to SonoCNS Start Alignment state. All measurements are cleared.
OmniviewRot.	Rotates the Omniview line.
Reload	Select Reload to reload the previous/next dataset (only available when a dataset is reloaded).

Using SonoCNS

1. Select SonoCNS either in 3Dpre, 3D or 4D write mode and press **Start** to acquire the volume. Then press **Start alignment** and the tool automatically extracts and displays 4 planes (TTP, TCP, TVP, MSP). Decide whether to accept the displayed alignment or to do a **Manual Alignment** if the result is not as desired.
2. Press **Start Measurements** to start the measurement process.
3. Decide whether to edit the measurements or to transfer them to the worksheet by pressing **Add to Report**.

Measurement buttons

The measurement buttons are displayed according to the measurements:

- gray background: No measurement was found, a manual measurement is needed.
- button highlighted in green: The measurement is selected for editing.
- black background: The measurement is available/done.

- black background, text grayed: The button is disabled.

Note *It is possible to configure measurements in the measure setup as well as performing manual measurements.*

Note *It is also possible to configure whether to additionally calculate OFD during the HC measurement.*

Guide

In combination with SonoCNS a **Guide** appears and can be used if desired. The **Guide** leads through SonoCNS and helps with clinical information.

8.7.7.6 SonoPelvicFloor

The SonoPelvicFloor tool is a guided tool for Pelvic Floor examination. It provides the user with:

1. The Coronal plane of the pelvic floor to recognize malformations or other anatomical variants.
2. Relevant measurements on the MHD plane – Levator Hiatus (LH) area, LH Lateral diameter, and LH Anterior-Posterior diameter.

The required 4D volume cine/3D volume can be newly acquired or reloaded from archive. VCI should be active with appropriate thickness (default set to 5mm) and the coronal plane should be upright (with Symphysis Pubis on the top) before a measurement is started.

SonoPelvicFloor menu

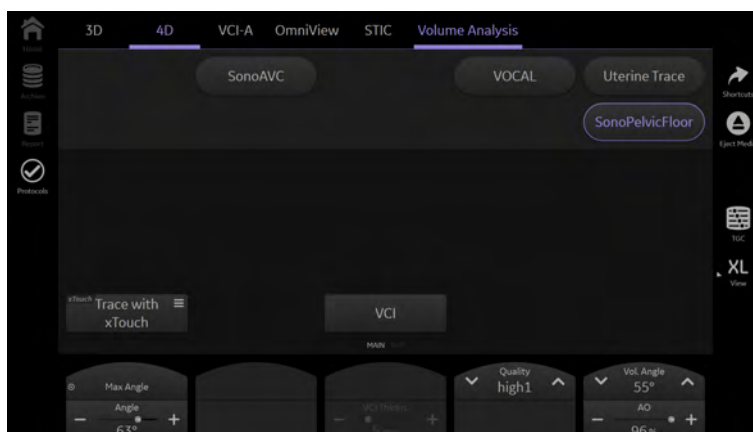

Figure 8-50 SonoPelvicFloor pre menu (example)

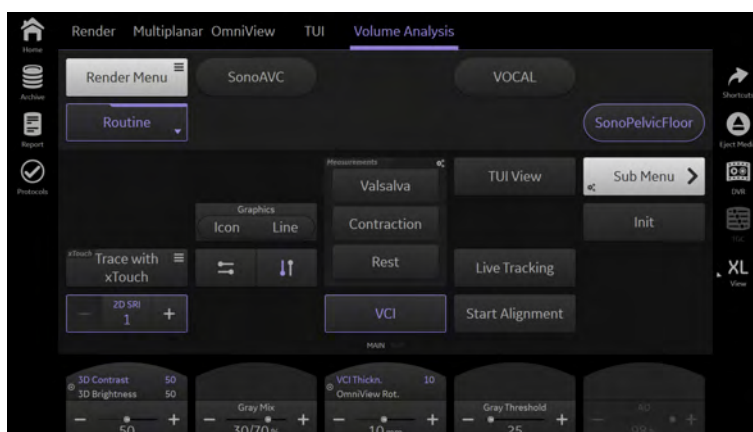

Figure 8-51 SonoPelvicFloor (example)

As most controls are the same as in 3D/4D acquisition modes only the SonoPelvicFloor relevant controls are described here:

Trace with xTouch

Press **Trace with xTouch** to open xTouch on the touch panel.

Valsalva / Contraction / Rest

As soon as one of the measurement buttons (**Valsalva / Contraction / Rest**) is pressed, the SonoPelvicFloor measure menu opens. If pressed, the Levator Hiatus measurement is performed by an AI algorithm automatically. When the AI algorithm is finished, all measurements are performed. Accept the results or adapt the measurements. If the AI algorithm cannot find the necessary structure in the image, it is possible to perform the measurements manually.

When a measurement is finished, the 4D SonoPelvicFloor frozen menu appears.

Note *It is possible to reorder the measurement buttons within the box as desired. Press onto the configuration symbol to select between **Configuration** (enables the touch menu configuration for the measurement box) and **Back to Default** (restores the factory configuration).*

Start Alignment

If pressed, the image is aligned automatically by an AI algorithm (only available in dual format).

Live Tracking

If pressed, an AI algorithm is activated, which aligns the line automatically to its optimal position if the corresponding structure is available in the image. The algorithm tries to adjust the line for each frame in the cine. It is also possible to scroll through the cine manually. When invoked by the user, the button is activated/deactivated automatically as soon as a valid structure is found.

Note ***Live Tracking** is option dependent and only available when option that supports **Live Tracking** is set.*

TUI View / Exit TUI View

If **TUI View** is activated, the TUI slices are displayed in the image. Press **Exit TUI View** to return to SonoPelvicFloor.

Note *It is possible to perform measurements in the A,B and C slides.*



Opens a help overlay explaining gestures in **xTouch**.

Using SonoPelvicFloor

Using SonoPelvicFloor (start in 3D/4D pre):

1. Select the corresponding 4D preset or go to the Volume Analysis Pre menu and select SonoPelvicFloor. If desired, activate **Live Tracking**.

Note *On reloaded data go to the Volume Analysis menu and select SonoPelvicFloor.*

2. Draw a line (Omniview line) with the trackball on the screen or with a finger on the touchpanel in xTouch. After this, the acquisition starts.

Note *Draw the SonoPelvicFloor Omniview line across the plane of minimal hiatal dimension starting from the side of the symphysis pubis towards the levator ani (see image below).*

3. Adjust the plane while staying in 4D, do a scan and afterwards press **Freeze**.
4. Scroll through the cine to find the correct frame with the trackball.
5. Optional: press **Start Plane Alignment** – an algorithm adjusts the OmniView line to identify the correct plane. if the algorithm output is not satisfactory, it is possible to manually adjust the Omniview line.
6. Perform the desired measurement (**Valsalva, Contraction or Rest**) and go to **TUI View** if desired.

Using SonoPelvicFloor (start in 3D):

1. Go to **Volume Analysis** in 3D mode and select SonoPelvicFloor.
2. Draw a line (Omniview line) with the trackball on the screen or with a finger on the touchpanel in xTouch. After this, the acquisition starts.

Note *Draw the SonoPelvicFloor Omniview line across the plane of minimal hiatal dimension starting from the side of the symphysis pubis towards the levator ani (see image below).*

3. Optional: press **Plane Alignment** – an algorithm adjusts the OmniView line.
4. Perform the desired measurement (**Valsalva**, **Contraction** or **Rest**) and go to **TUI View** if desired.

Using SonoPelvicFloor (start in 4D):

1. Go to **Volume Analysis** in 4D mode, press **Freeze** and select SonoPelvicFloor.
2. Draw a line (Omniview line) with the trackball on the screen or with a finger on the touchpanel in xTouch.

Note *Draw the SonoPelvicFloor Omniview line across the plane of minimal hiatal dimension starting from the side of the symphysis pubis towards the levator ani (see image below).*

3. Scroll through the cine to find the correct frame with the trackball.
4. Optional: press **Plane Alignment** – an algorithm adjusts the OmniView line, or **Live Tracking** – an AI algorithm adjusts the line in RealTime
5. Perform the desired measurement (**Valsalva**, **Contraction** or **Rest**) and go to **TUI View** if desired.

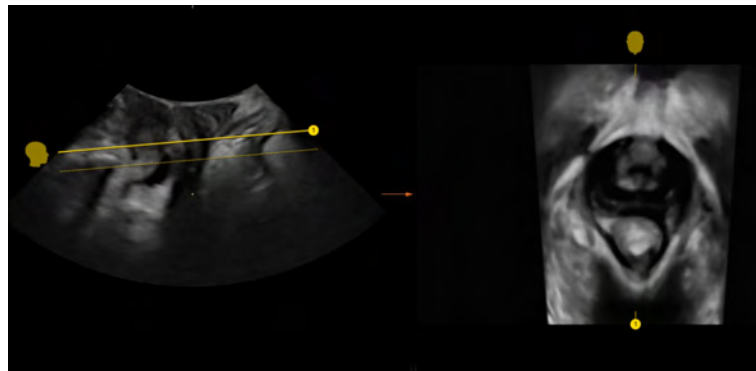

Figure 8-52 SonoPelvicFloor (example)

In combination with SonoPelvicFloor a guide appears and can be used if desired. The guide leads through SonoPelvicFloor and helps with clinical information.

8.7.7.7 Uterine Trace

Uterine Trace is a guided way to visualize the coronal plane of the uterus to recognize malformations or other anatomical variants.

Note *To maintain orientation, this tool should be used with the transvaginal probe orientation marker, or 'notch' at or near the 12:00 position.*

Note *Uterine Trace is an option and only available for GYN probe applications in 3D pre-mode and 3D mode.*

Uterine Trace Menu

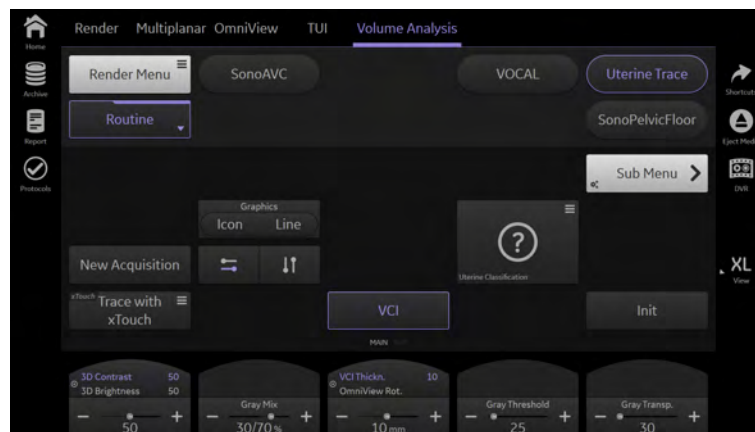



Figure 8-53 Uterine Trace Menu in 3D Mode (example)

As most controls are the same as in 3D/4D acquisition modes only the **Uterine Trace** relevant controls are described here:

Trace with xTouch	Opens the Uterine Trace xtouch menu. The trace remains.
New Acquisition	Activates Uterine Trace pre mode. The line is cleared.
Uterine Class.	Opens the classification menu.
Volume Analysis Tools	Select the available Volume Analysis tools.
VCI	Turns VCI imaging on or off.
Orientation	Select the desired orientation (up/down, left/right).
	Opens a help overlay explaining gestures in xTouch .

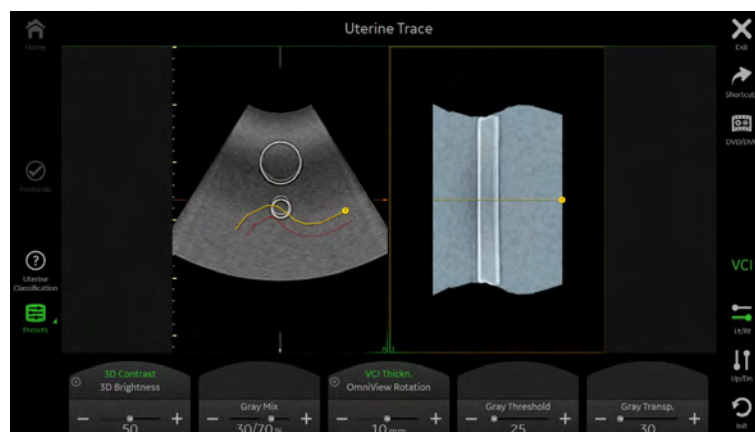

Figure 8-54 Uterine Trace xtouch Menu (example)

Using Uterine Trace

1. Select any preset with GYN application.
2. Press the **3D** button and then go to **Volume Analysis** and **Uterine Trace** on the touch screen.
3. Draw a trace on the endometrium with your finger on the touch screen and modify it if necessary by pressing **New Line** or **New Acquisition**.
4. The rendered image is shown. Open the classification menu and select the desired item.

8.7.7.8 Fibroid Mapping



Caution

Fibroid Mapping shall be used with volumes that contain the whole uterus and all fibroids. For optimal result use volumes acquired with empty bladder.



Caution

Fibroid Mapping is only available for volumes acquired with transvaginal probes.



Caution

Fibroid Mapping is not intended for use with Saline Infused Sonography (SIS) exams.



Caution

Fibroid Mapping is not intended for use in patients with Intra-Uterine devices (IUD)



Caution

Fibroid Mapping is not intended to detect uterine malformations.

Fibroid Mapping is a tool to assist in detection of uterine and endometrium contour in relation to size and location of fibroids.

- To maintain orientation, this tool should be used with the transvaginal probe orientation marker, or 'notch' at or near the 12:00 position.
- This is an option and only available for GYN probe applications in 3D pre-mode and 3D mode with probes RIC5-9-D.

Possibilities to invoke Fibroid Mapping:

1. Pre mode: select 3D and then press **Fibroid Mapping**.
2. Acquisition mode: select **Volume Analysis** in 3D/4D mode and then press **Fibroid Mapping** if not active already.

Fibroid Mapping menu



Figure 8-55 Fibroid Mapping pre menu (example)

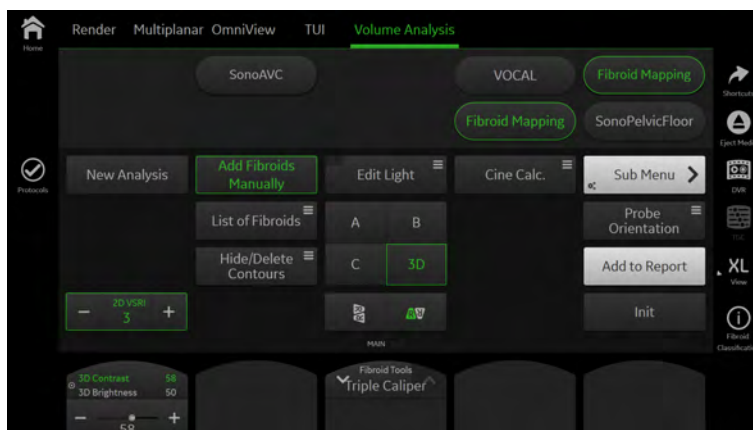



Figure 8-56 Fibroid Mapping menu (example)

As all controls are the same as in 3D/4D menus, only the Fibroid Mapping relevant controls are described here:

Fibroid Mapping	Opens Fibroid Mapping .
New Analysis	Opens the Fibroid Mapping pre menu.
Add Fibroids Manually	With this function not detected or wrongly detected fibroids can be added manually. Manually added fibroids are marked with an asterisk.
List of Fibroids	Opens the list of found fibroids. It is possible to select the type and position of fibroids. It is also possible to add comments and to hide selected fibroids from the render view.
Hide/Delete Contours	Select the desired display option: <ul style="list-style-type: none"> ● Hide uterine volume ● Delete uterine volume ● Hide endometrial volume ● Delete endometrial volume ● Hide uterine trace line <p>Hidden structures are not displayed on the 3D rendering window, but their contours are still displayed on multiplanar planes and their data is added to the report. Deleted structures are removed from the multiplanar planes and not added to the report.</p>
	Opens the help menu for Fibroid Classification in the FIGO help menu.

Result Window



FIBROID MAPPING

Uterus Volume: 34.44 cm³
Endometrium Volume: 12.34 cm³

#	D1 <small>(mm)</small>	D2 <small>(mm)</small>	D3 <small>(mm)</small>	Avg. D <small>(mm)</small>	V <small>(cm³)</small>
1	1.9	1.8	1.7	1.7	6.7
2	1.9	1.8	1.7	1.7	6.7
3*	1.9	1.8	1.7	1.7	6.7

Figure 8-57 Fibroid Mapping Result Window (example)

The **Fibroid Mapping Result Window** contains the **Uterus Volume** and **Endometrium Volume** and a list of all found fibroids. Manually added fibroids are marked with an asterisk.

Using Fibroid Mapping

1. Do a scan and find the mid-sagittal plane, then enter **Fibroid Mapping** via **3D pre / Volume Analysis** and select **Fibroid Mapping**.
2. On the touch display or with the trackball on screen draw a curve along the endometrium from the fundus to cervix. The auto segmentation is started automatically and the segmented uterus and endometrium are displayed.
3. Confirm probe orientation.
4. Use the parallel shift knob to navigate through the volume. Click on all fibroids and the system will detect the contours. Add fibroids manually if needed by pressing **Add Fibroids Manually**. Then select the desired measurement tool:
 - **Ellipse**
 - 4.1.1. Position the start-point of the long diameter with the Trackball and press **Set**.
 - 4.1.2. Position end-point of the long diameter with the Trackball and press **Set**.
 - 4.1.3. If desired press **Change** to adjust the start- and end-point.
 - 4.1.4. Adjust the short diameter with the Trackball press **Set**.
 - 4.1.5. To start the next measurement move the Trackball and continue with step 1.
 - **Double Caliper**
 - 4.2.1. Position the start-point of the long diameter with the Trackball and press **Set**.

- 4.2.2. Position end-point of the long diameter with the Trackball and press **Set**.
 - 4.2.3. If desired press **Change** to adjust the start- and end-point.
 - 4.2.4. Move the Trackball and so the green measurement cross appears.
 - 4.2.5. Position the start-point of the short diameter with the Trackball and press **Set**.
 - 4.2.6. Position end-point of the short diameter with the Trackball and press **Set**.
 - 4.2.7. To start the next measurement move the Trackball and continue with step 1.
- Triple Caliper
 - 4.3.1. Position the start-point of the long diameter with the Trackball and press **Set**.
 - 4.3.2. Position end-point of the long diameter with the Trackball and press **Set**.
 - 4.3.3. If desired press **Change** to adjust the start- and end-point.
 - 4.3.4. Move the Trackball and so the green measurement cross appears.
 - 4.3.5. Position the start-point of the short diameter with the Trackball and press **Set**.
 - 4.3.6. Position end-point of the short diameter with the Trackball and press **Set**.
 - 4.3.7. Position the start-point of the next short diameter on the B Plane with the Trackball and press **Set**.
 - 4.3.8. Position end-point of this next short diameter on the B Plane with the Trackball and press **Set**.
 - 4.3.9. To start the next measurement move the Trackball and continue with step 1.
5. Any time during the workflow use the format selection keys to enter single or quad view formats and see the 3D render window. In the 3D render window the segmented contours of the identified structures (uterus, endometrium and fibroids) can be observed. Use the X, Y and Z rotation knobs to adjust the 3D render view. Use the programmable keys to save images and add to your report.
 6. Select **Add to Report** to save the current measurements to the current exam.

8.7.7.9 Spine Trace

Spine Trace is a guided way to visualize the spinal plane.

Note When **Spine Trace** is activated, a guide appears.

Note **Spine Trace** is an option and only available for OB probe applications in 3D pre-mode and 3D mode.

Spine Trace Menu

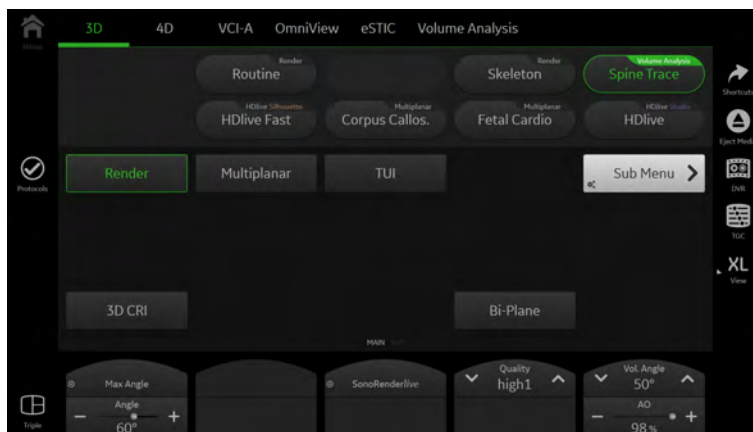

Figure 8-58 Spine Trace Menu in 3D pre-mode and 3D Mode (examples)

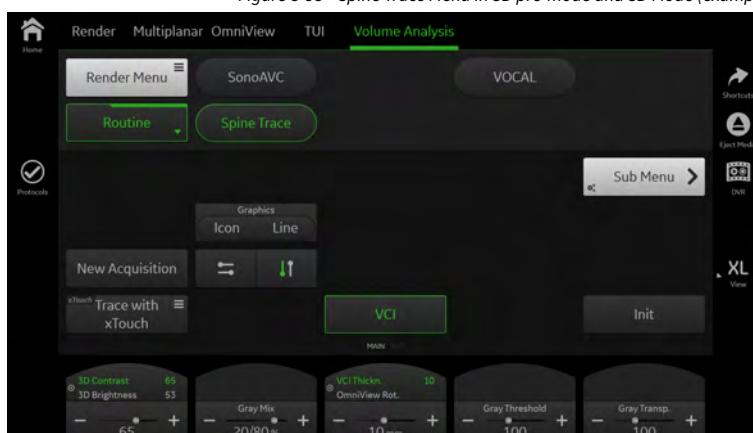

Figure 8-58 Spine Trace Menu in 3D pre-mode and 3D Mode (examples)

As most controls are the same as in 3D/4D acquisition modes only the **Spine Trace** relevant controls are described here:

- Trace with xTouch** Activates Spine Trace xTouch menu.
- New Acquisition** Activates Spine Trace pre mode. The line is cleared.
- Volume Analysis Tools** Select the available Volume Analysis tools.
- VCI** Turns VCI imaging on or off.
- VCI Thickn.** Thickness adjustment.
- Orientation** Select the desired orientation (up/down, left/right).
Opens a help overlay explaining gestures in **xTouch**.

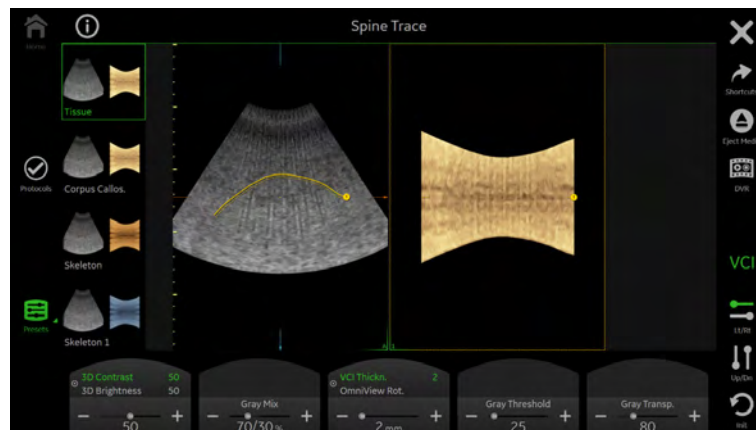

Figure 8-59 Spine Trace xTouch Menu (example)

Note Position the trace line in the A-plane on the spine thus the sliced spine is shown.

Using Spine Trace

1. Select any preset with OB application.
2. Press the **3D** button and then go to **Volume Analysis** and **Spine Trace** on the touch screen.
3. Draw a trace on the spine with your finger on the touch screen and modify it if necessary by pressing **New Line** or **New Acquisition**.
4. The rendered image is shown.

8.7.8 Probe Orientation

In order to simplify orientation in a 3D or 4D data set the user can activate the display of directions like cranial, caudal, left, right, anterior, posterior at the border of the 3D or 4D data set. The user has to select the position and the rotation of the probe in respect to the patient (or in obstetrics in respect to the fetus) at the time of acquisition. Then the actual display of the directions has to be activated manually. When the volume is rotated the orientations at the border of the image are automatically adjusted accordingly. The display remains active until a new acquisition is performed or until it is turned off by the user. If the display is activated and the data set is saved, the probe orientation settings are stored in the data set. If the display is turned off however, probe orientation settings are not stored.



Caution

Ensure that the actual probe position corresponds to the probe orientation configuration.
Special precision is required in Acquisition Mode 4D. Moving the probe can lead to errors in displayed directions with respect to the displayed image.

Probe Orientation Menu

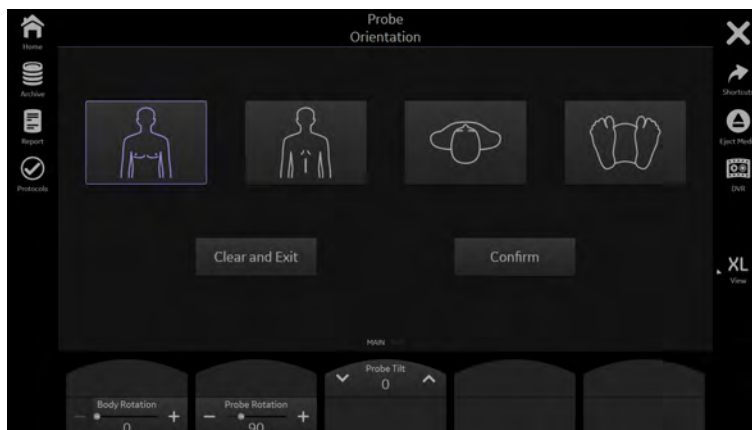

Figure 8-60 Probe Orientation Menu

Exit	Press Exit to go back to the previous menu.
Clear and Exit	Return to 3D/4D menu without applying changes. The orientation marks in 3D/4D mode are hidden. Reset of probe orientation setting to default values. This key is only available if probe orientation menu has been activated once.
Confirm	Activate new settings or changes. The 3D/4D Menu is active and orientation markers are displayed in 3D/4D mode.
Body patterns	<ol style="list-style-type: none"> 1. Front: The body pattern can be rotated in steps of 45°. 2. Back: The body pattern can be rotated in steps of 45°. 3. Top view: The body pattern cannot be rotated. 4. Bottom view: The body pattern cannot be rotated.

Probe Orientation screen display

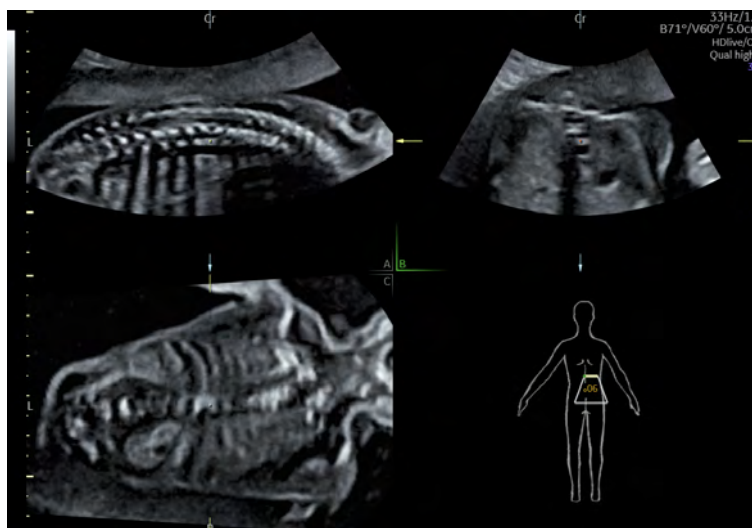

Figure 8-61 Probe Orientation screen display

The lower right quadrant displays the body pattern and the probe marker, independent of the selected visualization mode. Position of body pattern (body view and body rotation) and probe marker are stored in the 3D/4D user program.

The green point on the probe marker indicates the rotation of the probe (like Voluson™ Signature 18 / Voluson™ Signature 20 system-Logo on 2D image).

Note *The Orientation marks appear on the Rotation Axis in the A-, B-, and C-Plane. They change according to the rotation of the slices.*

Following orientation markers are available:

A	Anterior
P	Posterior
L	Left
R	Right
Cr	Cranial
Ca	Caudal

There are also combinations thereof possible e.g.: AL, PRCa etc.

Note *The orientation marks are visible if slices are present in T.U.I. mode (not in Render Full-Screen). They are visible as long as they are not turned off, by touching **Off** in the Probe Orientation Menu.*

8.7.9 Tint Menus

Gray 2D Menu

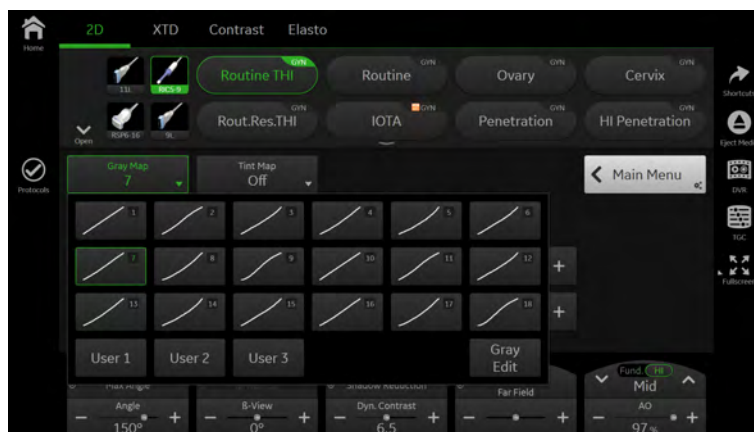

Figure 8-62 Gray 2D Menu

1. Touch **Gray 2D** to open the menu.
2. Select either a predefined Gray Curve or a user-definable Gray Curve.
3. To edit a Gray Curve, touch the **Gray Edit** button. Changes will not be stored unless you select a certain position and press **Exit** afterwards.
4. Touch **Exit** to return to the previous menu.

Tint 2D and Tint VCI Menu

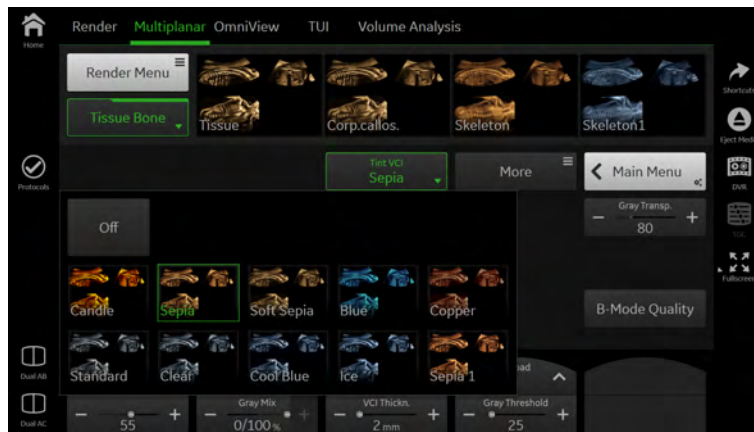

Figure 8-63 Tint 2D and Tint VCI Menu

1. Touch **Tint 2D** or **Tint VCI** to open the menu.
2. Select one of the tint maps by touching the map button.
3. Touch **Exit** to return to the previous menu.

Tint 3D Menu

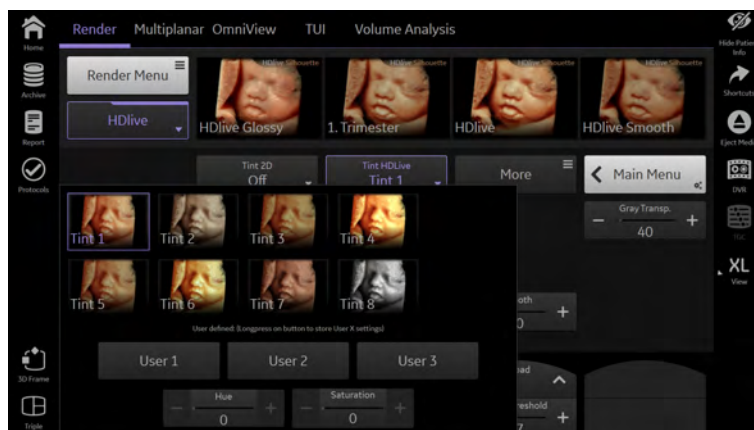

Figure 8-64 Tint 3D Menu

- Save** Saves the current tint map modified with **HUE** and **Saturation** under one of three user buttons which can be selected in a pop-up window.
- HUE** HUE is available in HDlive™ only.
The HUE of the selected map can be changed between +/- 50 steps by using the rotary encoder. The value is set to 0 when the encoder switch is pressed.
- Saturation** Saturation is available in HDlive™ only.
The Saturation of the selected map can be changed between +/- 50 steps by using the rotary encoder. The value is set to 0 when the encoder switch is pressed.
- Off** Deactivates the current tint map.
- Default** Set the value back to its default value.
- Start** Default: 60
- Slope** Default: 30

1. Touch **Tint 3D** in the 3D Sub Menu.
2. Select one of the tint maps by touching the map button.

- 2.1. In HD*live*™ Mode **HUE** and **Saturation** can be modified. Press **Save** to store the modified Tint Map as a user defined color.
- 2.2. If **Depth Coloring** is available, Color Transition can be modified by turning the rotary controls below the touch panel.
3. Touch the **Exit** button to close the menu.

This page was intentionally left blank.

Chapter 9

Archive

<i>Open Archive</i> -----	9-3
<i>Data Transfer</i> -----	9-8
<i>Source</i> -----	9-17
<i>Patient ID</i> -----	9-20
<i>Clipboard</i> -----	9-25

The Voluson™ Signature 18 / Voluson™ Signature 20 system provides an Image Management System that allows fast and extremely easy image management. It allows users to view, print and transfer images stored in the Voluson™ Signature 18 / Voluson™ Signature 20 system. In addition, it allows users to send and receive DICOM images over the DICOM Network.

Note *The images are stored according to the patient's ID. If there is no ID assigned to the current images, enter an ID for proper storing.*

The results of calculations are recorded in application dependent patient worksheets. By pressing **Report** the worksheet page is switched on.

Note *Local Archive/ Anonymized Archive:
To avoid long loading times, the number of Patients/ Exams are restricted to 500.
For displaying all Patients/ Exams press the button **Show all Patients** or **Show all Exams** (depending on the selected Archive view.*

9.1 Open Archive

No exam started

To open the Archive press the **Archive** button on the touch panel.

Exam started

First, press the **Archive** button on the touch panel, the **Exam Review** with the images from the current ongoing exam appears on the screen. To enter the **Archive** press the **Archive** touch panel button.

Note *If a current exam is open, it is not possible to reload data from closed exams. Current exams have to be closed first. Therefore a dialog appears asking whether to close the current exam or not.*

Usage without ultrasound hardware/probe

The Archive can be started without a connected probe by pressing the **Archive** button on the touch panel.

If no probes are connected, following functions are disabled:

- **Use as current**
- **Reopen Exam**

Exam Review works without any change.

The Archive menu appears:

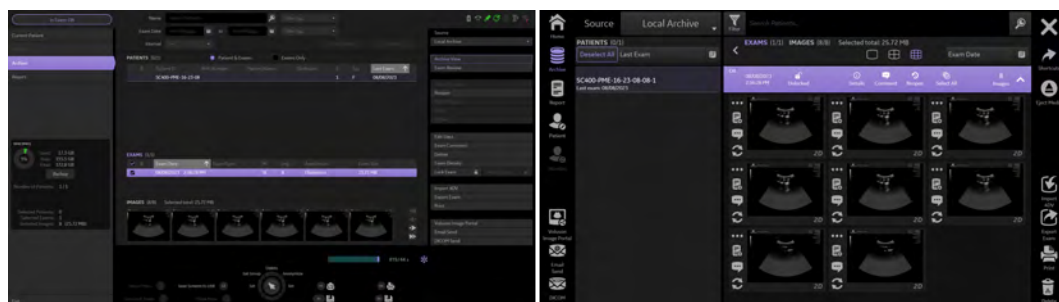
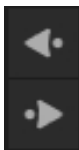

Figure 9-1 Archive menu

Menu controls

Source	Select the location of the database: <ul style="list-style-type: none"> ● Local Archive (Harddisk) ● 4DV (Network, USB) ● DICOM Server ● Anonymized Archive
Search	Starts the search process. Apply the search criteria and list only found exams/patients/ images. The search process can also be started with AN keyboard button Return .
Show All	Displays all patients.
Patients & Exams	Group list by patients
Exams only	Lists exams only (not grouped by patients).
	Display next/previous image in the thumbnail row of the dialog.



Display next/previous page of the images in the thumbnail row.



Lock/unlock of selected exams.

Note See 'Lock/Unlock/Backup Exams' on page 9-6

AN keyboard: Pg Up/Dn
AN keyboard: Left/right

Previous/next patient (Patient List) or exam (Exam List).

Displays next/previous page of the images in the thumbnail row.



Icon that indicates whether a patient/exam has already been backed up. Shows also whether a backed up patient/exam has changed since the last backup.

Single click/tap on an image

Select image (green border)

Note On the **Archive** screen a direct selection/deselection of patients/exams is possible by clicking onto the checkbox in the header.

Double click/tap on an image

Open image in Exam Review Full Screen Mode

Information box

List details on storage capacity and selection.

Exam Review

With **Exam Review** the state of the current exam can be reviewed before ending the exam. It can be checked if all necessary items are examined, necessary images are saved and all measurements are done. Images can be selected for deletion/printing and export. Reloads can be annotated, measured, post processed and saved again.

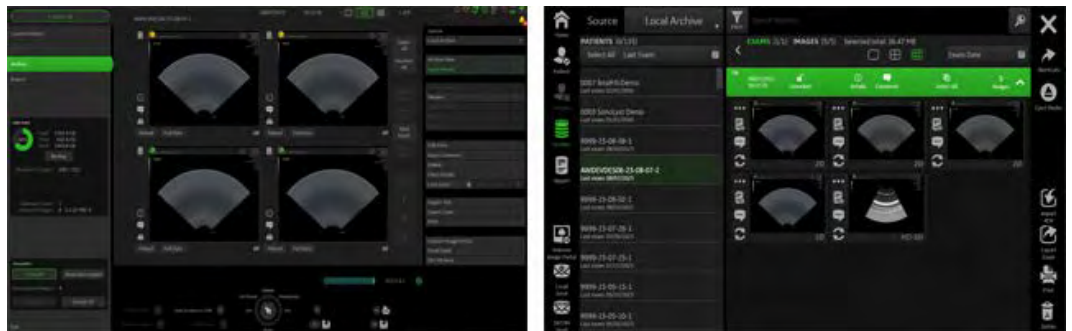

Figure 9-2 Exam Review (example)

As most controls are the same as in **Archive View**, only the **Exam Review** relevant ones are described here:



Displays information about the image/exam.



Opens the exam/image comment window. Enter the desired comment and press **OK** to save (icon turns green) or **Cancel**.

Reload

Reloads raw data images from a current/ongoing exam or another selected exam.

Acquisition Type

Displays the acquisition type of the data set.

Full Data

Displays all available data and relevant controls for the selected dataset.



Scroll up/down.



Select the previous/next patient/exam.

SonoLyst^{live}

Displays unaccepted auto-captured images of an exam and the number of unaccepted images. Select whether to **Show all** / **Show Unaccepted** and to **Accept** / **Accept all**.

Trackball buttons

Button	Click	Patient List	Exam List	Thumbnail Image
Set	1x	<ul style="list-style-type: none"> highlight patient show exam list show thumbnail images of the first exam 	<ul style="list-style-type: none"> highlight exam show thumbnail images of the exam 	Select image (green border).
	2x	<p>Opens PID menu to start a new exam with the same patient data</p> <p>If a current exam exists, a dialog window appears.</p>	Opens Exam Review of the selected exam	Opens image in Exam Review Full Screen Mode.
Delete	1x	Opens context menu.	Opens context menu.	Opens context menu.
	2x	-	-	-
Anonymize	1x	Opens context menu.	Opens context menu.	Opens context menu.
	2x	-	-	-
Set Group	1x	Select a group of patients or exams. Select one patient/exam with Set . Move the cursor to desired end of the selection group and press Set Group . All patients/exams from the first and the last selection are selected.	Select a group of patients or exams. Select one patient/exam with Set . Move the cursor to desired end of the selection group and press Set Group . All patients/exams from the first and the last selection are selected.	-

9.1.1 Archive Screen and Touch Menu

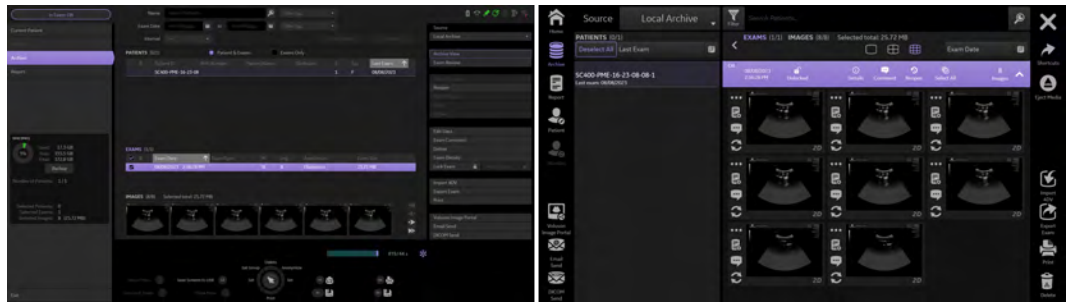

Figure 9-3 Archive Screen and Touch Menu (example)

Export	The Export dialog pops up. Export all data of the selected patients/exams or the selected images. This button is only active, if patients or exams or images are selected.
Delete	The Delete dialog pops up. Select the patient or exams or images to be deleted.
Import	Opens the Import dialog. <ol style="list-style-type: none"> 1. Select the desired import location and data type. 2. Press Open to import the selected data or Cancel to close the dialog without any action.
Use as current	Opens the patient dialog and uses data from the current selected patient.
Reopen	Reopens an exam which is not older than 24 hours. If the exam is older, this button is disabled.
DICOM send	Opens the DICOM send dialog.
Email send	Opens the Email send dialog.
Exam Review / Archive View	Exam Review opens the Exam Review screen. This button is only active if, an exam or an image is selected. Archive View closes the Exam Review screen and opens the Archive.
Show all	Lists all patients/exams/images.
Print	Prints all exams of the selected patient, all data of all selected exams or images. This button is active, if patients, exams or images are selected
Search	Search for patients/exams/images.
Exit	Exit Archive

Note *Dialog windows (i.e. **Export**, **Delete**,...) appear on the screen and on the touchpanel.*

9.1.1.1 Reopen Exams

If this button is pressed, the selected exam, which must not be older than 24 hours, is reopened. This is only possible without a current exam being open.

It is possible to add images like in a normal opened exam, e.g.:

- Reload a set, change it (rotation, color) and save it again.
- Create a new acquisition (2D, 3D, 4D,...) and save it.

Activities that are selected for **End Exam (Save, Send,...)** are only performed if images are added after the exam was reopened.

9.1.1.2 Lock/Unlock/Backup Exams

If an exam is locked, it is kept from being deleted. All other functions are available.

Using Lock/Unlock Exams

1. Select exams in the exam list.

2. Press **Lock/Unlock** to lock/unlock exams. A locked exam is marked with the **Locked** icon.

Deleting Patients/Exams/Images

If patients, exams or images are deleted, informative messages appear when locked exams are involved:

- Patient with all exams locked: "Your selection contains Exams that are locked and cannot be deleted!"
- Patient with some exams locked: "Your selection contains Exams that are locked and cannot be deleted! Do you want to delete the unlocked Exams?"
- Locked Exam(s) only: "Your selection contains Exams that are locked and cannot be deleted!"
- Images of a locked exam: "The selected image(s) belongs to a locked Exam and cannot be deleted!"

Press either **OK** or select between **Yes** (continue to delete) and **No** (close message and cancel deleting) to continue.

Backup

If a patient is already backed up, a backup icon displayed in the patient column [B] next to the patient.

9.1.1.3 Search

To search for a patient/exam/image, use the search area of the Archive Menu.

1. Apply your desired search criteria/filters and select the source where you want to search.

Note *When the source is the DICOM server, only reduced search possibilities are available.*

2. Press **Search**. The found results are displayed.

Note *If a search is ongoing and a filter is added or changed the **Search** button changes to **Update Search** to apply the changed search criteria.*

Sorting exams

To sort exams, click onto the caption of the column. The list will be arranged according to the selected caption.

9.1.1.4 Repro

Repro is the reload of work-settings of a stored picture. It is possible to recall the exact setting (e.g. Geometry, Gain, Colormap, etc.) from a stored picture.

Choose a picture at the Exam Review, Patient Archive or from the Clipboard whose settings Repro will recall. When using the repro function the same probe that was used when storing the image has to be connected. When the probe is connected press **OK**, all probe settings will be loaded automatically.

The repro can be loaded:

- Without new patient/exam
- with new exam
- with new patient

Note *It is not possible to use the Repro function with data sets created on systems with software prior to Voluson™ Signature 18 / Voluson™ Signature 20 system.*

9.2 Data Transfer

Data Transfer controls

	Patient selected	Exam selected	Image selected
DICOM send	Sends all Exams of the selected patient(s).	Sends all data of the selected exam(s).	Sends all selected images.
Email send	Sends all Exams of the selected patient(s).	Sends all data of the selected exam(s).	Sends all selected images.
Print	Prints all Exams of the selected patient.	Prints all data of the selected exams.	Prints all selected images.
Export	Export dialog opens. Exports all data of all exams of the selected patient.	Export dialog opens. Exports all data of all selected exams.	Export dialog opens. Exports all selected images.

9.2.1 Sending data

9.2.1.1 DICOM Send

Selected data is sent to the DICOM destination selected in the DICOM Config Dialog. If more than one DICOM destination is selected, a dialog appears where the destination can be selected within a drop down menu with all available destinations.

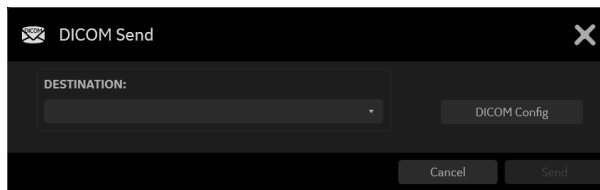

9.2.1.2 Email Send

It is possible to send data via Email.

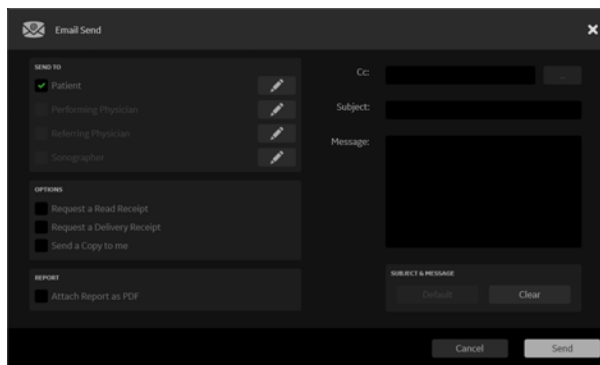

Figure 9-4 Email Send

Email Send

Send to	<ul style="list-style-type: none"> ● Patient ● Performing physician ● Referring physician ● Sonographer <p>All recipients with an included email address at the Patient ID menu are preselected. If no email address is entered, an edit button appears. Selecting this button opens the corresponding dialog.</p>
Options	<ul style="list-style-type: none"> ● Request a Read Receipt ● Request a Delivery Receipt ● Send a Copy to me <p>The last selection shall be stored for the next Email Send.</p>
Report	Select whether to attach the report as .pdf.
Cc	An additional email recipient can be added. If no recipient is selected, the "Cc" changes to "To"
Subject	Enter a subject.
Message	Enter a message or edit the previously stored one.
Subject & Message	A default subject and message (configured in the email system setup) can be entered by clicking Default . Clear deletes the subject and the message input field.

Sending data

1. Select the data to send. The Email send window appears.
2. Select the sending criteria (receiver, options,...) and type in a message if desired.
3. Press **Send** to send the data or **Cancel** to cancel the process.

9.2.2 Print

It is possible to print Ultrasound data. Therefore select the button **Print**. The printing dialog appears.

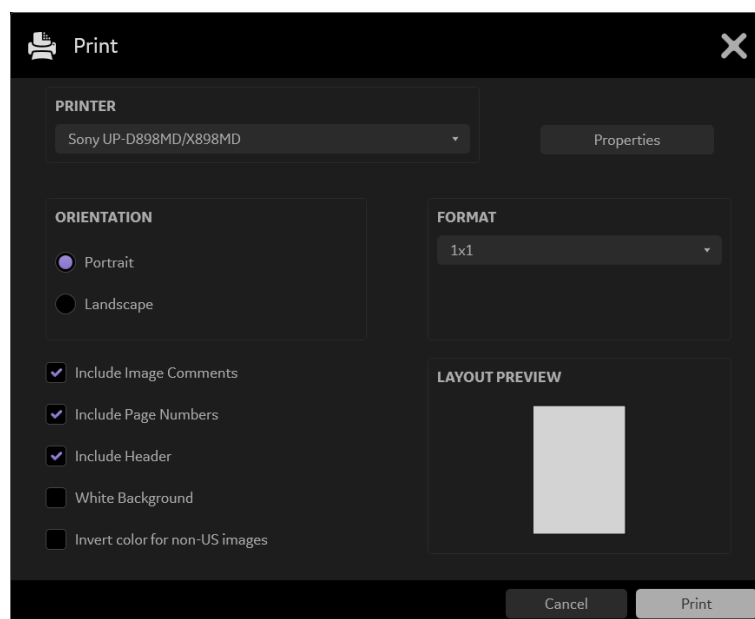

Figure 9-5 Non DICOM Printers and DICOM Printers

Instead of the button **Properties** the button **DICOM Config** appears when a DICOM printer is used. Including Image Comments/Page Numbers or a Header is not possible for DICOM printers.

Printing data

1. Select the data to print and press **Print**. The printing dialog appears.
2. Define the desired printing properties and press **Print** to start the printout.

Note *The Layout Preview displays the selected Format.*

Note *The Printer Settings menu is only for print jobs initiated with the Px buttons or from Archive. If you want to edit printer settings for print jobs initiated with the End Exam button, please refer to 'Button Configuration' on page 11-32.*

9.2.3 Export

Export of images in BMP, JPG, TIFF, PNG; Cines in MP4, AVI; Images and Cines can be exported in PC / MAC format (PNG & MP4) or TIFF/MP4 (TIF & MP4) and Volumes in VOL or RAW to a mapped Network drive, USB drive. To save all Patient Data and images use either compressed or uncompressed or encrypted 4DV. To export anonymized patient data and images select the 4DV anonymize file format.

- If a 3D Volume data set is selected, the complete data set can be exported as a dedicated Volume file. The stored Volume files can be reviewed with the PC program “4D View”.
- Stored images in BMP, JPEG, TIFF, PNG can only be reviewed on an external PC.
- When exporting an AVI/ MP4 file, there is a 4th progress bar, regarding each single frame. Therefore it is now possible to cancel an export any time.

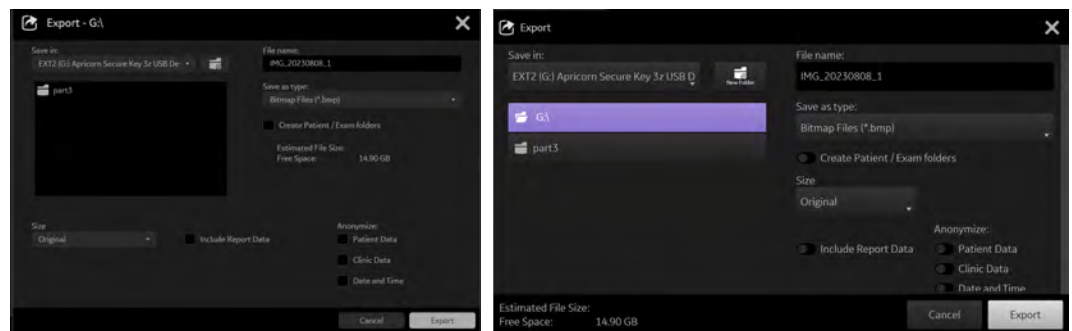

Figure 9-6 Export (screen and touch)

Note *It is possible to export an open, uncompressed 4dv archive to an export location without importing the 4dv archive first into the local archive. A compressed 4dv archive cannot be exported directly, it has to be imported into the local archive first.*

Note *It is possible to exclude images from the export by selecting do not include images (only enabled for .4dv formats).*

Remember last option

The following export dialog settings are always saved permanently into the system when the button **Save** is pressed to start the Export procedure. These settings are valid until to the next change and will always pop up in the export dialog.

- Save in: destination
- Save as type: file type
- type attributes: Size, Quality, Codec,...
- Anonymize: Patient/Clinic Data, Date/Time

Exporting data

1. Select the data for export and press **Export**. The export window appears.

2. Define the destination, the filename and select other desired properties (l. e. **Save as type**, **Create Patient / Exam Folders**, **Size**,...).
3. Press **Export** to export the data.

- Note**
- *The Anonymize function only works with Ultrasound images. It does not work with secondary captured images.*
 - *Compare the estimated file size with the free space on the desired export location. Do not export unless the capacity of the storage volume is bigger than the estimated file size.*
 - *If you want to additionally save the report data in a .txt or .pdf file format, select **Include Report Data**.*
 - *All patient and exam data will be saved in an automatically created folder, when the "Create Patient/Exam Folder" check box is selected. The folder will be named by the Patient(s) ID.*
 - *Images that were saved into the Archive using JPG compression are marked with a yellow **J** (e.g., J80 = compression factor 80%)*
 - *AVIs using MPEG4 compression cannot be played on a Windows® PC without the right codec installed. Please download the DivX codec from www.divx.com and install it on your computer in order to view MPEG4-encoded AVIs!*



Caution

A lossy compression can reduce image quality which can lead to a false diagnosis!

9.2.3.1 Anonymize function

Following data can be made anonymous if checked:

1. Patient data
 - Name (last/first/middle)
 - ID number (ID only, not GA or LMP display)
 - 2nd patient ID (if enabled in System Setup)
 - Date of birth

Note *If an existing Patient ID is entered, a green Patient ID header and a green checkmark appear.*

2. Clinic Data
 - Clinic name
 - Sonographer
3. Date/Time
 - Date and Time
4. Measurements and Annotations
 - **Anonymize Measurements and Annotations** removes all measure and annotation overlays and clears all measure and biometry relevant data in the worksheet/report

The Anonymize function is only available for the following image types:

- avi
- jpeg
- png

- bmp
- tif
- mp4

It is not available for the following image types:

- 4DV
- vol
- raw

Note *If some images cannot be made anonymous a message appears.*

9.2.3.2 Export Mesh

Export mesh is available for 3D/4D Volume render data sets (excluding VCI data sets) and includes **High**, **Mid** and **Low** quality.

By choosing the following file formats a mesh (e.g. for 3D printing) is exported:

- STL File Format (*.stl)
- Stanford Polygon File Format (*.ply)
- Alias Wavefront Object File Format (*.obj)
- Point Cloud File Format (*.xyz)
- 3D Manufacturing Format (*.3mf)

It is possible to select between full and projected mesh for each format. For Stanford Polygon File Format (*.ply), Alias Wavefront Object File Format (*.obj) and 3D Manufacturing Format (*.3mf) a selection for export as texture is possible .

Note *Exporting as a projected mesh is only possible with render data sets.*

9.2.4 Voluson Image Portal

Voluson Image Portal enables sharing of images from the Voluson Archive to an external mobile device.

Note *If there is a WiFi device connected without WiFi Hotspot functionality, the **Voluson Image Portal** button is not available.*

If a WiFi Hotspot can `t be started, following messages appears:

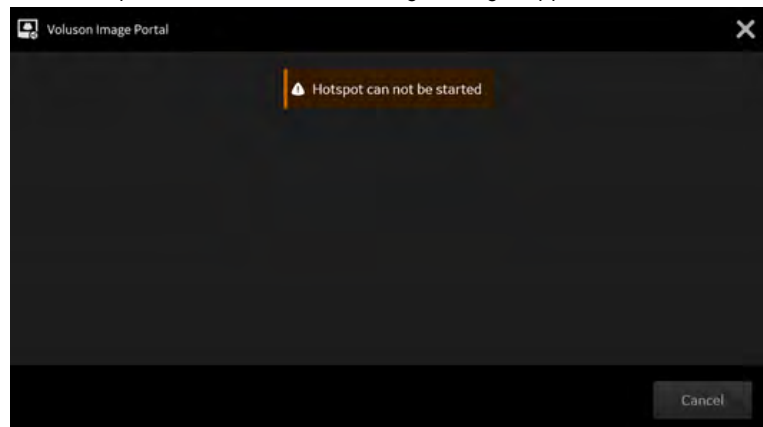

Using Voluson Image Portal

1. Select an exam or an image for sharing with the Patient and press the Button **Voluson Image Portal**.

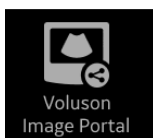
**Note**

While starting the WiFi Hotspot, following message is displayed:

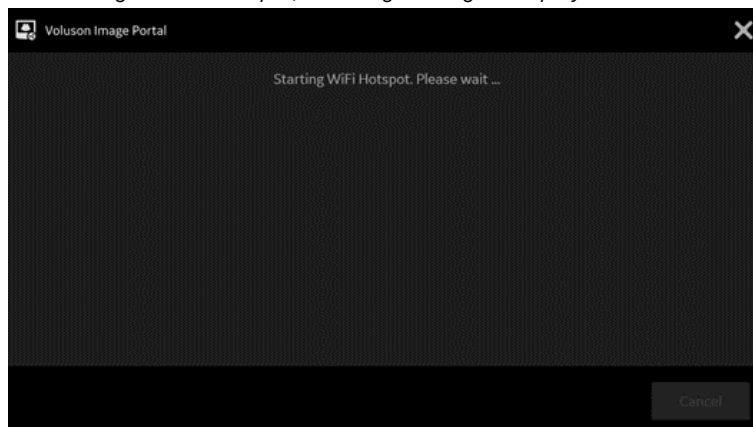

- The 1st QR code appears. It has to be scanned by the Patient to create a WiFi connection between the system and the Patient`s mobile device.

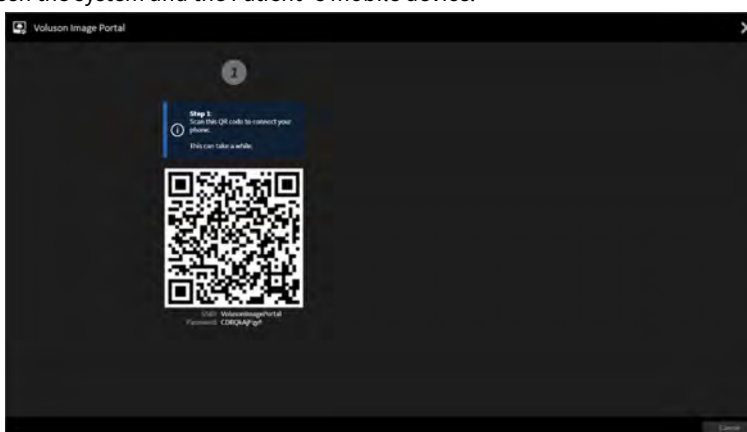

- The 2nd QR code appears and has to be scanned to open the **Voluson Image Portal**.

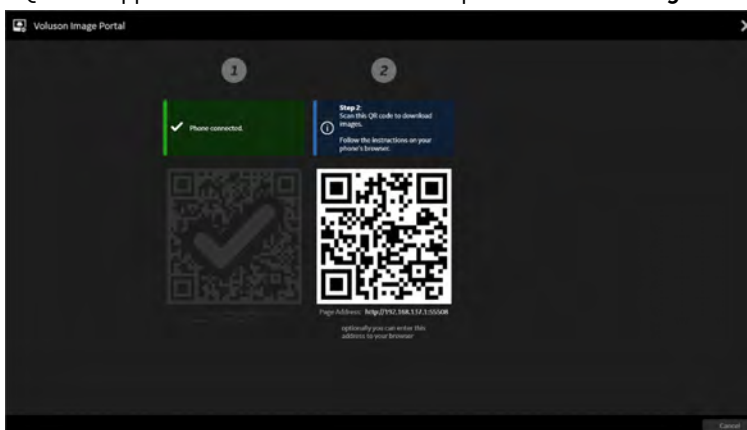

- The Patient can now press the "Download" button on Patient`s mobile device to download the images.

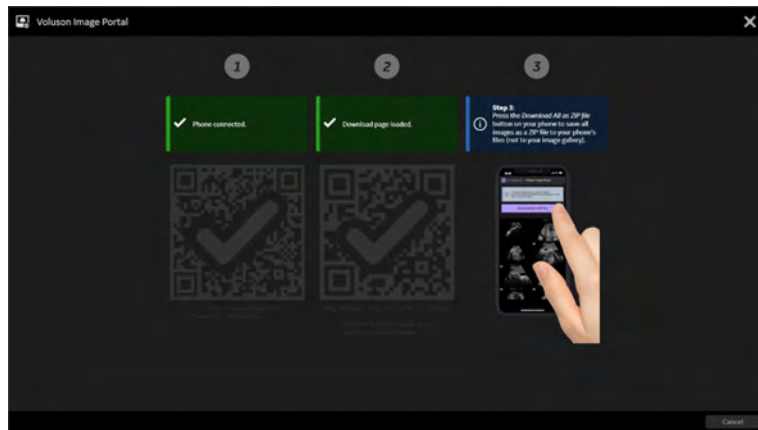

Note

The Images will be downloaded as a .zip archive including .png and/or .mp4 files.

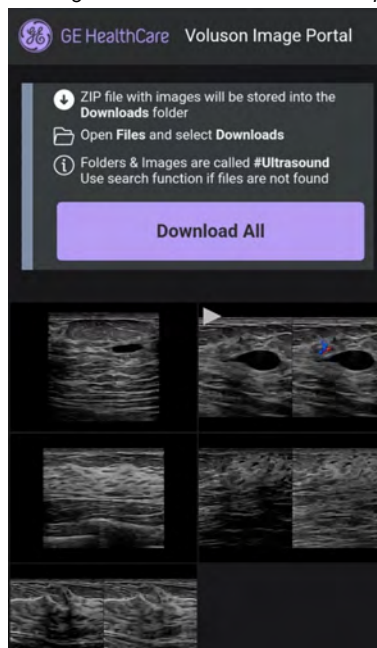

5. A finished download shows a green Step 3 badge. The Voluson Image Portal can be closed with a **Close** button.

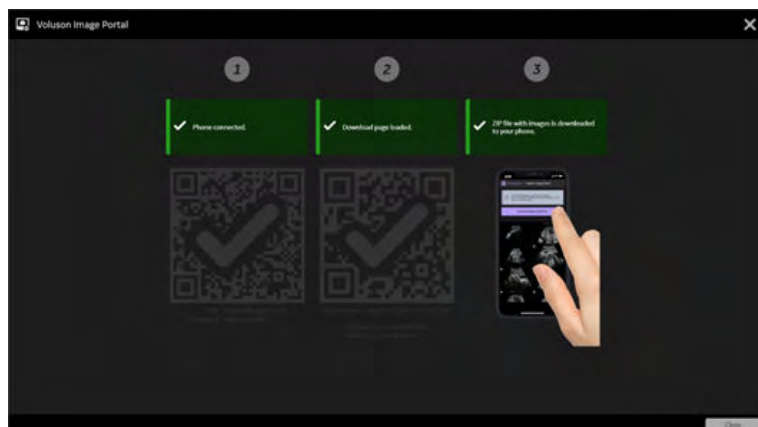

9.2.5 Import

Using Import

1. Select **Source - 4DV** or press the button **Import** to open the Import dialog.

2. Select
 - the location of the file you want to import data from
 - the desired 4DV file
3. Confirm by pressing **Open** to open the Import Preview.
4. To import the data from the Import Preview to the local archive press the button **Import** again.

All data contained in the 4DV file is displayed in the Archive window under the source category "4DV". The user can now select the patients and exams that he wants to import. If an encrypted 4DV file is selected, a password prompt appears. The entering of a wrong password causes an error message.

Pressing the button **Import** copies the data to the local hard drive. If files are missing/corrupted and cannot be imported/restored, a warning appears.

If an exam is currently ongoing a dialog appears asking whether the exam should be closed. Press **Yes** to close the exam and to start the import process or **No** to close the dialog window without closing/importing the exam.

Import Preview from USB

It is possible to review and/or reload data directly from the selected location. In reload state you can **Send** and **Print** but not **Save**. When **Save** is selected following message appears: "SAVE not possible! Exam must be imported first".

After closing this window with "OK" another dialog appears. It tells the user to press **Import** again to copy the data to the hard drive permanently (restore).

Possible to import:

- selected patients
- selected exams
- selected image and volume data

Importing from a DICOM Server (Query Retrieve)

Exams, patients and images from a DICOM Server can be imported after Query/Retrieve was performed. It is only possible to import complete exams or patients, not single selected images. If no images are available, the **Import** button is disabled.

9.2.6 Delete

Deleting patients, exams or images

1. Select the data (patient(s), exam(s) and/or image(s)) to delete.
2. Press the button **Delete**.
3. A dialog appears which asks for confirmation to delete the selected items.

Controls

Delete Images only	Selected image(s) will be deleted.
Delete All Data	All selected data will be deleted.
Cancel	Cancel deleting data.



Warning

Everything you choose to delete will be deleted permanently.

9.2.7 Backup

For more information see 'Backup' on page 11-46.



Caution

It is highly recommended to create a configuration backup of settings and patient data regularly.

The data from the backup always replaces the corresponding data on the Voluson™ Signature 18 / Voluson™ Signature 20 system.

9.3 Source

Selection for different archive sources:

1. Local Archive (Archive stored on the local hard drive).
2. 4DV (Opens 4DV file from an external source).
3. DICOM Server (Query and Retrieve patient and image data from a DICOM Server).
4. Anonymized Archive (Anonymized Archive stored on the local hard drive).

9.3.1 Local Archive

Default source for the local stored archive.

9.3.2 Anonymize Archive

This function allows to anonymize patients, exams and/or images in an own locally stored archive.

Figure 9-7 Anonymize dialog

Using Anonymize Archive

1. Select the to anonymize data (patient, exam or image) from the local archive.
2. Press the trackball button **Anonymize**.
3. The Anonymize dialog appears.
4. It is possible to add anonymized data for:
 - Patient ID
 - Last name
 - Middle name
 - First name
 - Date of birth/Age
 - Gender
 - Exam Comment
 - Exam type
 - Exam date
5. Press the button **OK** for starting the anonymize process. If more than one patient is selected from the local archive for copy to the Anonymize Archive, the dialog appears that often. If more

than one exam from different patients is selected from the local archive for copy to the Anonymized Archive, the dialog appears only once. All exams are included in one patient ID.

Controls

Generate Patient ID	Generates by default a patient ID. It is also possible to create an own patient ID.
Patient ID	If an existing patient ID is entered, a green checkmark appears and the button Advanced Settings appears. It extends the Anonymize Dialog with existing exams. It is possible to add the selected Patient/Exam/Image to an existing exam or create a new exam.
Generate Patient ID automatically	If checked, Generate Patient ID is grayed and a Patient ID prefix must be entered.
Anonymize Exam Date	If checked, the existing exam date will be replaced with a randomly generated date.
Delete Data from local archive	If checked, all patient data will be deleted after a confirmation.
OK	This button creates a new exam for the selected patient.
Clear All	Clears all fields.
Cancel	Cancels the procedure.

9.3.3 DICOM Server

The selection **DICOM Server** is only available when a Query/Retrieve Server is configured and selected in the DICOM Configuration Dialog. When the DICOM Server is selected, the archiving screen changes.

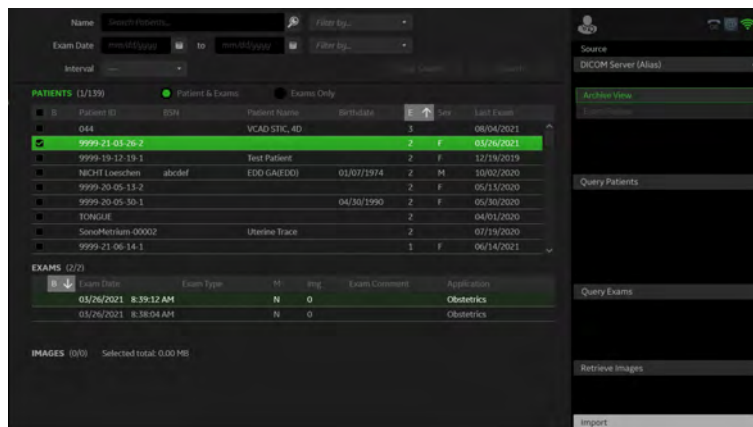

Figure 9-8 DICOM Server

Note *As long as no query was performed, no stored data are available on the DICOM Server dialog. All lists (Patients, Exams, Images) are empty. Also the buttons **Query Exams** and **Retrieve Images** are disabled.*

Using DICOM Server

1. Enter search criteria if desired.
2. Press **Query Patients**.
3. The list of patients is filled with the patients from the DICOM Server that match the given criteria. (Field **E** and **Last Exam** are empty because the exams belonging to this patient are yet unknown.)
4. Select one or more patients from the list.
5. Press **Query Exams**.
6. The list of exams is filled with the exams of the selected patient. If more than one patient is selected, exams for these patients are available when switching between patients.
7. Select one or more exams from the list.

8. Press the **Retrieve Images** button.
9. A dialog with a list of images that are retrieved and a status indication is displayed
10. The process of retrieving images can be canceled by pressing **Cancel**.
11. After the images are retrieved the dialog vanishes and thumbnails of the retrieved images are displayed.
12. In the **Archive** all buttons are now enabled.
13. The **Import** button is now available.
14. Select a patient or exam and press **Import** to import the selected data into the local archive. If the data is not imported, it is stored locally until a new exam is started. This means that it is possible to switch back and forth between menus and modes, without losing the query-data until a new exam is started. The locally stored temporary data is also deleted upon reboot.

9.3.3.1 DICOM Details

DICOM Server Details

- Port 105 is used for retrieving the images. (This needs to be configured on the remote DICOM server.)
- Only DICOM images that are marked as US (ultrasound) or “secondary capture” can be retrieved. (No CT images for example.)
- Only data that was requested by the Voluson™ Signature 18 / Voluson™ Signature 20 system is accepted. It is not possible to request from a third system data to be sent to the Voluson™ Signature 18 / Voluson™ Signature 20 system.
- The port is only open during retrieve. During the retrieval the system is locked. It is not possible to continue working while retrieving data from a remote server.



Note *Not possible to use DICOM Storage Commit and Query Retrieve with the same DICOM Server. It is usual to receive images and storage commits both on port number 104.*

9.3.3.2 Exam Application Details

The Clinical Application is set from the DICOM Image file. If more than one Clinical Application is used in one exam, the Clinical Application is set from the last DICOM Image.

Note *If no Clinical Application is included in the DICOM Image file (e.g. secondary capture) then the default Clinical Application from the DICOM Config. dialog will be set.*

9.4 Patient ID

Press the  hard key or  on the touch panel to open the Patient Menu.

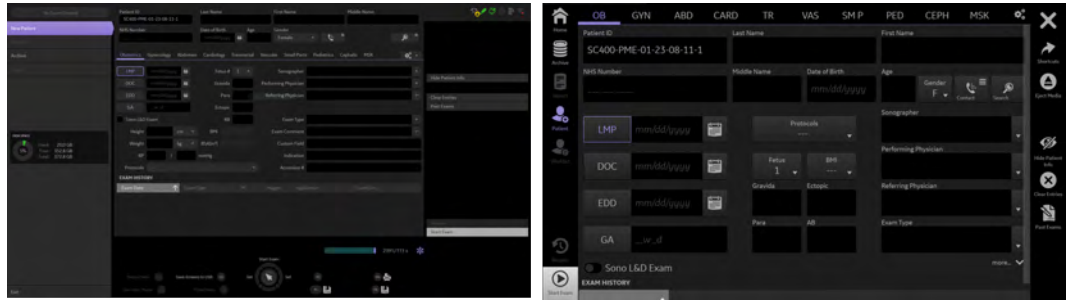

Figure 9-9 Patient ID Menu (Screen and Touch example)

Controls

- Patient ID** Displays the Patient ID. Can be used as search criterion.
- Note** *If a new ID number matches to an existing ID number, this is indicated by a green Patient ID header and a green checkmark.*
- 2nd Patient ID** Entry field for a 2nd Patient ID: Only visible if activated in the system setup/dependent on the system setup settings. The name can be BSN, NHS or 2nd Patient ID.
- First/Last/Middle Name, DOB, Age, Gender** Patient data input fields. Following data can be entered:
- ID number
 - 2nd Patient ID
 - First/Last/Middle Name
 - Day of Birth (DOB): When the DOB is entered, the age is calculated automatically.
 - Age: When the age is entered, the day of birth is cleared.
 - Gender
- Contact** Opens a window to enter the email address and phone number of the patient. By pressing **Manage Contacts** data of the performing/referring physician or the sonographer can be entered.

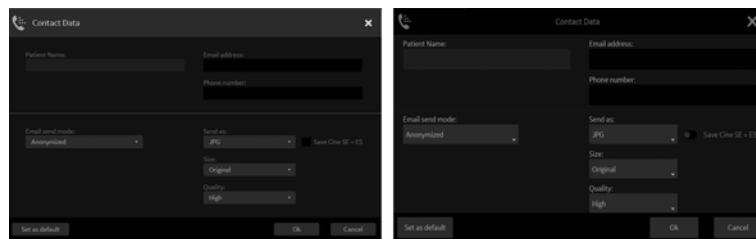

Figure 9-10 Contact Data (example)

Enter data (**Patient Name, Email Address, Phone Number**), **Email send mode, Password, AES-256** encryption, **Send as, Size, Quality, Cine SE/ES** as desired. Press **Set as default** to save the settings as default, **Cancel** to leave the menu or **OK** to apply the changes.

Configuration -



To set the visibility of the exam applications press the configuration button. A popup appears. Select/check the applications to be displayed, unchecked applications are not visible.

Note *If the current exam application is unchecked, this application is still visible as long as no tab change happens. After an exam application tab change, this tab is not visible anymore.*

Search Opens the search dialog. Use the information from the patient data input fields to start a search of the patient database.

Exam Application (OB, GYN,...) Exam data input fields. Depending on the selected exam application following data (details can be configured in the System Setup, e.g. date format for LMP, DOC etc. or whether the last entered sonographer's name is still displayed after the exam is ended,...) can be entered:

- Height (cm, inch, ft/inch)
- Weight (kg, lb, oz)
- Last Menstrual Period (LMP): The first day of the last period has to be entered. (GA and EDD are calculated automatically.)

Note *When the GA (LMP) is edited it becomes GA (Clin). When the LMP is edited afterwards, a message appears asking whether the GA should be recalculated from the new LMP.*

- Date of Conception (DOC) (GA and EDD are calculated automatically.)
- Date of Conception (DOC / DAY 3 / DAY 5) (GA and EDD are calculated automatically.)
- Estimated Date of Delivery (EDD) (GA is calculated automatically.)
- Gestational Age (GA) (EDD and DOC are calculated automatically.)
- Gravida/Para/AB/Ectopic: Patient's history of pregnancies
- Number of fetuses

Note *When the number of the fetus is changed, a message appears asking for confirmation.*

- Date of Expected Ovulation (Exp. Ovul.)
- Day of Cycles
- Day of Stimulation (The Day of Stimulation is updated automatically when a new exam of the same patient is started.)
- Body Surface Area (BSA)
- Height (The BMI is calculated automatically when the height and weight are entered.)
- Weight (The BMI is calculated automatically when the height and weight are entered.)
- BMI
- Blood Pressure
- Heart Rate (HR)
- PSA
- PPSA Coefficient 1 and 2
- Access #

Note *If a new exam is started for an existing patient the accession # is cleared for the new exam.*

- Protocols (Select a Scan Assistant List or Assessment Tool if available.)

Drop down lists/entry fields are available for entering following data:

- Referring/Performing Physician/Sonographer
- Exam Type
- Exam Comment

Note *It is only possible to enter max. 20 exam comment or exam type entries. If more than 20 entries are made, the last entry is deleted automatically.*

- Custom Field
- Indication
- More... / Less....

It is also possible to delete entries from the list, cancel the process or save the entered data with **OK**.

Note *“, #, [,], ^, *, %, _ , ? and individual apostrophe characters are not allowed to be entered. After pressing **Enter** on the AN keyboard or the onscreen keyboard the next input field is selected automatically.*

Note *The current disk usage is displayed on screen. As soon as the disk usage exceeds 80%, the color of the indicator turns orange and the button **Backup** appears. Press **Backup** to directly enter the **Backup** within the System Setup. Additionally the number of queried patients and the last successful worklist data update are displayed.*

Menu Controls

Input field select:	Select the desired input field for direct access.
Worklist	Switch to the Worklist. Only available when an exam is started/selected.
Worksheet	Switch to the Worksheet. Only available when an exam is started/selected.
Past Exam	Opens the past exam dialog.
Search	Opens the Search window. Uses the information from the Patient data input fields to start a search of the patient database.
Clear Entries	Deletes all input fields except the Patient ID.
Hide Patient Data	Hides the patient information on the screen (depending on the system setup configuration).
Exam	Select whether to reopen, add, end or start an exam.

Entering and changing data

1. Select an input field with the trackball or tap. Press **Set** to position the cursor.
2. Enter patient/exam application information.
3. Press **Enter** or the **Tab** key to go to the next input field.
4. Before leaving the menu a dialog appears asking whether to save any changes while an exam is ongoing. Press **Yes** to save the changes or **No** to leave without saving the changes.

Using Worklist

1. Press **Worklist** to enter the Worklist search dialog.
2. Enter the desired search criteria (configurable by opening the dropdown and setting the depending radio button on the touch panel):
 - Search Key (Patient Name or Patient ID)
 - Accession #
 - Start Date
 - End Date
 - Procedure ID
 - Station Name
 - Station AE Title

Note *If more than one worklist services are configured, the desired searchable worklist server can be selected.*

3. Press **Search** to start the search on the currently active worklist server.

Note *A Server Alias is only visible if more than one Worklist is selected in the DICOM Configuration.*

4. Select the desired patient/exam to close the Worklist dialog. All received Worklist entries are inserted into the Patient ID menu.

- Press **Start Exam** to close the Worklist dialog. An exam is started with all received Worklist entries without showing in the Patient ID menu.

Searching for patients

To search for single patients define the desired search criteria and press **Search**.

Close the Patient Menu by pressing **Exit** either on the screen, the touch screen or the hard key console.

9.4.1 Past Exam

Press **Past Exam** to open the Past Exam dialog. This dialog is used to enter data from previous ultrasound exams performed on other systems. Only available when OB is selected.

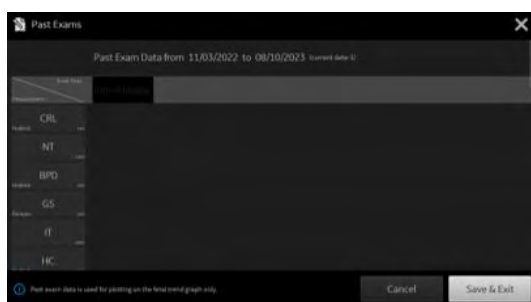

Figure 9-11 Past Exam

Controls

Past Exam Data shown from	Shows data starting at this date.
to	Shows data ending at this date.
Exam Date	Create a new entry by entering an exam date.
Measurement Fields	Enter measurement data from previous exams performed on different systems.
Delete	Delete the selected exam date by pressing Clear . A message appears asking for confirmation.
Cancel	Return to the patient dialog without saving data.
Save & Exit	Return to the patient dialog and save data.
Fetus	Switch between the fetuses.

9.4.2 MPPS Procedure Step Dialog

The procedure step dialog lists all procedure steps belonging to the selected procedure. If a procedure with more than one procedure step is retrieved from the worklist, only one entry is created. The number of steps is given in the Step # column. If an entry from this list is selected and the **Select** button is pressed, the "Procedure Step" dialog is displayed.

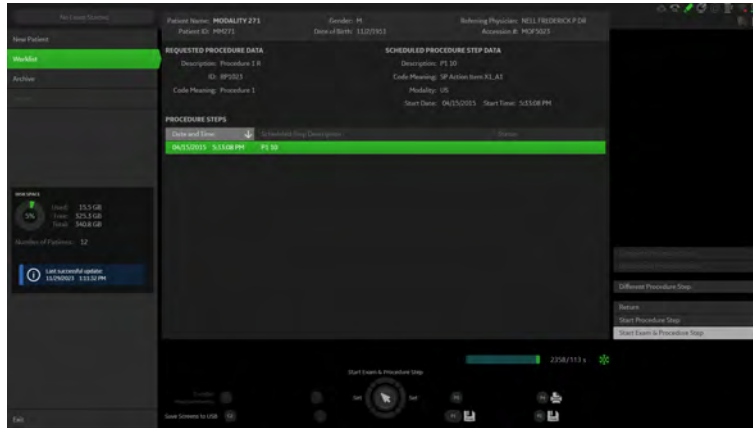

Figure 9-12 MPPS Procedure Step dialog (example)

Controls

- Complete Procedure Step** Completes a step by sending a MPPS complete message. Only available when a step is in progress.
- Discontinue Procedure Step** Cancels a step by sending a MPPS discontinue message. Only possible when a step is in progress.
- Different Procedure Step** Creates a different procedure step.
- Select Procedure Step** Select a Procedure step. Only available when no other step is in progress or started. This button does not start the procedure immediately (**Start Exam** has to be pressed). The Patient dialog returns.
- Start Exam and Procedure Step** Starts the procedure step. Only possible when no other step/exam is already in progress.
- Start Procedure Step** Starts the procedure step immediately. Only possible when no other step is in progress.
- Return** Returns to the Worklist dialog or the patient menu depending on where the procedure step dialog was started from.

9.5 Clipboard

The Clipboard displays stored US data of the current exam as preview images. Pressing one of the P-buttons stores active image information and displays a preview on the clipboard. (This implies that the respective button has been configured.)

Images of other patients will not be saved onto clipboard. If you reopen and continue an old exam, then the images of this exam will be displayed on the clipboard. For more detail an image will be enlarged by positioning the mouse cursor over the respective image.

Clipboard Screen layout

There are 3 different screen layouts available, which can be changed by touching the buttons at the bottom:

- 4 x 1
- 6 x 2
- 9 x 3

The 3 different Clipboard title bars (No Exam started, New Exam, Reloaded Exam) contain information about the started exam type, the duration time of the current exam, the number of thumbnails on the clipboard and the used capacity. No such information is provided without an exam started.

The Clipboard is visible at every mode except System Setup, Measure Setup, PID and Archive. Within Measure and Annotation Text the Clipboard can be shown depending on the system setup.

9.5.1 Image markers

The thumbnails at the clipboard have different image markers.

Cine display	Through Access Cine Symbol	Turquoise bar with red marker.
	Bitmap Cine Symbol	Triangle: <ul style="list-style-type: none"> ● Rot. Cine ● Trans. Cine ● Slice Cine ● Sweep Cine
Export	Colored dot in a circle.	
	If the export process has not yet been performed, the dot of the symbol appears green. If the image has already been exported, the dot of the symbol appears red.	
Delete	Images marked for deletion have a red cross across the image.	
Reload	Reloaded images have a green frame around the image.	
Move	Images marked to move have a red frame around the image.	
Added to worksheet	When an image is added to the worksheet with a Px-button the image has a green check mark.	
Tool tip	While the cursor is positioned over a clipboard-image, the acquisition mode of this image is shown.	

9.5.2 Saving onto the Clipboard

Press the predefined Px-button (default: **P1**) on the user interface to save data onto the clipboard.

Note Pressing the Px-button without having started an exam will show a dialog:

You have to start an exam first!

- **Ok:** Evokes the Current Patient Dialog to enter a patient. After entering the patient data and returning to scan mode using the **Start Exam** button the image or cine will be stored automatically.
- **Cancel:** Cancels the dialog and returns to scan mode. No patient has been entered and pressing the Px-button will lead to the same dialog.

The clipboard is filled from left to right and from top to bottom. When one page is full, a new page is created for the next images to come.

To change between pages:

1. Press **Pointer** on the user interface, if the cursor is inactive.
2. Click the triangle on the left or right of the displayed page-count.

Saving reloaded data

Edited, reloaded images (Measurements, Annotations...) have to be saved to the clipboard again, or else all changes will be lost when an other image is reloaded.

Depending on the system setup, saving of reloaded data follows certain rules:

- **Overwrite reloaded Image:** replaces the current reloaded image
- **Copy to the end of the clipboard:** saves an additional copy at the of the clipboard
- **Copy after the reloaded Image:** saves an additional copy after the reloaded image

Note Existing dataset information will not be lost. (independent of the setting “Copy after the reloaded Image”)

- When a Volume Cine is saved as Singe Volume, the Volume Cine will not be overwritten. The saved Single Volume will be saved to the end of the Clipboard.
- If a 2D cine is saved as (single) image, the 2D Cine will not be overwritten. The image will be saved to the end of the clipboard.
- All screenshots are saved to the end of the clipboard.
- Save TUI one by one does not replace the reloaded volume but will be saved to the end of the clipboard.

To switch fast between images, use either the keyboard Pg/Up, Pg/Dn buttons or the touch panel control up/down.

9.5.3 Manipulating Files on the Clipboard

Use the trackball buttons to manipulate data on the clipboard.

Reload from the clipboard

Press **Reload** to reload the full screen image.

Note Disabled in Measure- and Annotation Text mode.

Note Only one data set can be selected.

Repro function in clipboard

Press **Repro** to load and use the stored image presets.

Note Disabled in Measure- and Annotation Text mode.

Export from the clipboard

Press **Export** to mark an image for export onto an external device (multiple selections are possible) or for sending by email (if configured) or **Voluson Image Portal**. The export index appears in the lower, left hand corner of the image.

Press **Start Export** to export the images without ending the exam. The export index marker is deleted again.

Note *The image(s) will be deleted after ending the exam. The export dialog will appear. For more information see 'Export' on page 9-10.*

Move clipboard images

With the Move function the order of the clipboard thumbnails (with all their image markers) can be changed. This function is only available when more than one image exists.

1. Press **Move** to select an image. The selected image is framed red.
2. Use the cursor to move the selected image to any position on the clipboard.
 - 2.1. Press **Cancel** to stop moving the image.
 - 2.2. Press **Insert** to move the image to the selected position.

Note *If any blank slots are in between, the inserted image will be automatically placed behind the last clipboard image.*

Delete from the clipboard

Position the cursor over an image and press **Delete** to mark an image for deletion (multiple selections are possible). The deletion mark, a red cross, appears across the image.

Note *The image(s) will be deleted after ending the exam. There will be no confirmation dialog.*

Note *Deletion using the trackball also works in the Exam Review.*

9.5.4 Exam History (Compare)

The Exam History displays the image content from a former exam on the clipboard area. If the exam history clipboard is switched off, the current exam content is displayed.

The exam history clipboard can be closed by pressing a Px button to save images. A Compare window is only available when an exam history clipboard is open and can only be closed by the user.

If no history exam exists, no exam history buttons are available. They become available as soon as a new exam is started and an older exam exists.

Compare

The Compare function is used to show one image from an old exam on the screen together with a current image. The Compare image can be resized and positioned freely (drag and drop) during live scanning. It is shown on screen after it was selected from the exam history with the system cursor (green frame) and by pressing the trackball button **Compare**.

The Compare window is switched off automatically when one of the following functions is activated: End Exam, Util. PID, Probe, Report, Review, CALC, Caliper, Bodymark, Arrow. As soon as the Compare View is switched off the Exam History window is enabled.

This page was intentionally left blank.

Chapter 10

Measurements and Calculations

Measurement Menu ----- 10-3
Generic Measurements ----- 10-7
Additional Measure Tools ----- 10-18
Calculations ----- 10-22
Worksheet/Report ----- 10-30
Assessment Tools ----- 10-44
Accuracies ----- 10-47

Measurements and calculations derived from ultrasound images are intended to supplement other clinical procedures available to the attending physician. The accuracy of measurements is not only determined by system accuracy, but also by the use of proper medical protocols by the user.

Basically there are two measurement modes:

1. Generic measurements (general measurements not assigned to a specific clinical application)
2. Calculation measurements (special measurements and calculations belonging to specific clinical measurement applications)

Measurements can be performed in all modes and image formats. During a measurement the measurement caliper can be active (green) or fixed (yellow). A dotted line is displayed to indicate the path of the measurement (can be deactivated in the Measurement Setup).

A measurement is identified by the number assigned to it at the end of the measurement. The same number is used to identify the measurements in the result window (max. 8).

Every measurement is saved immediately after it was performed.

Dual format measurements

If the desired measurement area exceeds one image, it is possible to acquire a second image (2D dual format) to take the measurement over both 2D images.

Note *These two images have to have the same geometrical area (zoom).*

Dual format measurement is not possible in:

- Motion Modes (M, AMM, CW, PW)
- 3D/4D
- Quad format
- XTD

Accuracy of Measurements



Caution

The results achieved in various application specific modes (i.e. SonoAVC™, SonoNT,...) always depend on the accuracy of the procedure performed. Any clinically relevant decisions based on ultrasound measurements need to be reconsidered and treated carefully.

The possible accuracy of geometric, flow speed or other measurements with this ultrasound system is a result of various parameters that shall be equally considered. The used images shall be optimized and scaled to provide the best view of the examined structures. To ensure this, the correct choice of the ultrasound probe and imaging mode for a certain clinical application plays an essential role.

Despite the high theoretical accuracy of the scan geometry and the measuring system of the Voluson ultrasound system, it is important to be aware of increased inaccuracies caused by the ultrasound beam traveling through the inhomogeneous human tissue. Therefore differences between operators shall be minimized by standardization of procedures.

For more information see Advanced Acoustic Output References.

For more information see 'Bioeffects and Safety of Ultrasound Scans' on page 2-35.

10.1 Measurement Menu

Press **Calc.** to open the measurement main menu.

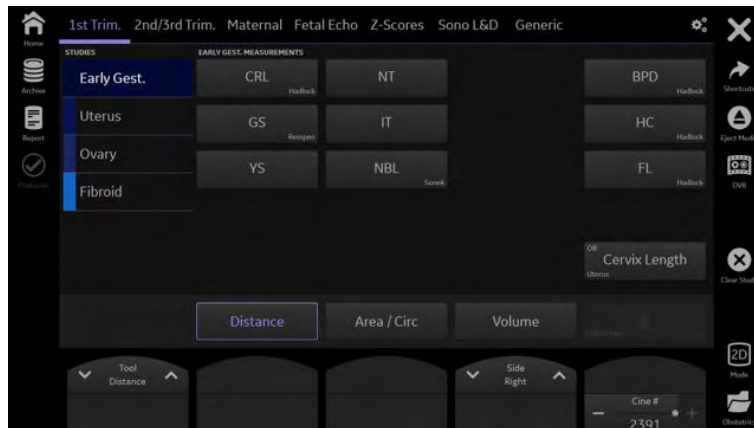

Figure 10-1 Measurement Main Menu (example)

Measurement Menu Controls

Sub categories	Shows all available sub categories and the generic measurements depending on the selected imaging mode.
Studies	Contains all available studies of the selected subcategory. The study name and the corresponding application are shown in the header.
Measurements	Shows all available measurements depending on the selected measurement study.

Note *Long Bones: The attribute neutral/left/right is displayed if it is selected in the measure setup (Select **Obstetrics**, then **Measurement** and then define **Use Left/Right for fetal Long Bones**). Select the desired measurement method within the worksheet to calculate the EFW.*

As soon as a measurement is performed at least once, a counter showing the number of measurements is displayed in the right upper corner of the button. The counter is updated automatically as soon as a measurement is deleted and reset when **Start Exam** or **End Exam** is pressed.

If an **Auto Trace** measurement configured as **Auto Sequence** is canceled manually by selecting another measurement, the **Auto Sequence** is stopped until it is started manually again.

Generic measurements	When the measure menu is opened and no exam is active, the first generic measurement is selected automatically. If an exam is active and the measurement menu opened, the last used generic measurement is selected. Following generic measurements are available in every measure application if configured in the measure setup:
----------------------	--

PW Mode:

- Auto Trace
- Vel.
- HR.

M Mode:

- HR
- Time
- Dist. 2 Point

other modes:

- Distance
- Area / Circ
- Volume

Imaging Mode	Change between 2D, M and D measurements.
Clear Study	Clears the study.
Delete Last/Cancel	Deletes the last measurement or cancels the current not finished measurement.
Side	Left/Right switch for side-dependent group measurements.
Measurement Application	Opens the measurement application menu.
Transfer Data	Sends a report to the remote report server.
Fetus	Select the desired fetus.

Note *A small measure menu is displayed in the miscellaneous area on screen if selected in the measure setup.*

Measurement Application Menu

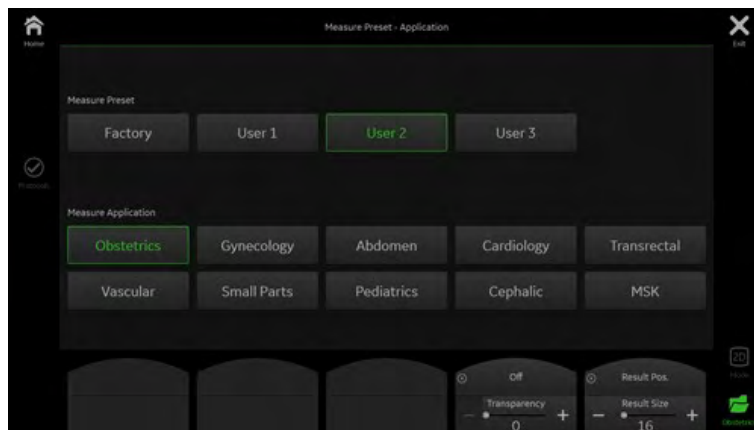

Figure 10-2 Measurement Application Menu (example)

The Measurement Application Menu displays Measure Presets (1 Factory and 3 user-definable presets) and Measure Applications.

With **Result Size** the font size of the results can be adjusted and **Result Pos.** enables positioning the result display with the trackball (green border). **Transparency** enables adjusting the transparency of the measure result background. With **Off** the transparency can be switched off.

Exit closes the window.

Measurement Magnifier Window

With the help of the magnifier window the measurement cross can be positioned more precisely. The current cross position is displayed within a square magnification window next to the actual measurement cross. The area is updated in real time when the measurement cross is moved. The magnifier window can be activated/deactivated by pressing **Magnifier** on the trackball.

Using the Magnifier Window

1. Press **Magnifier** (only available if a green cross is present on the screen to perform a measurement). The magnifier window and a positionable measurement cross are displayed.
2. Move the measurement cross to the desired position. As soon as the measurement is finished, the green measurement cross and the measurement window disappear.

Post Assignment

Post Assignment is only available if it is activated in the System Setup.

Post Assignment means that a generic measurement can be converted to a measurement which is selected by the user. The color of the measurement buttons, for which post assignment is possible, is brighter than the standard color.

It is possible to have a post assignment when:

- the start point of a generic measurement is set (If a possible measurement is selected, the end point is set at the cursor position and the performed generic measurement is converted to the selected measurement. If a measurement is not possible, the process is cancelled.)
- the generic measurement is finished (only the latest finished measurement is converted to the selected measurement)

Using Post Assignment:

1. Perform a generic measurement.
2. Select one of the possible measurements (brighter buttons) to assign the measurement. The generic measurement is converted into the selected measurement.

10.1.1 Measure Configuration

It is possible to configure the measurement menu (measure area and study configuration) as desired.

A long press on  activates the configuration.

Measure area configuration

Enter the calculation menu and then press  for a long time to activate the configuration.

The measure area configuration includes:

- Adding a study / measurement
- Resizing a study
- Moving / reordering a study / measurement
- Deleting a study / measurement
- Renaming a study or subcategory
- Editing a study color



Closes the configuration menu as well as another press onto . As soon as changes are made a dialog appears asking whether to keep the changes (**Yes**), discard them (**No**) or **Cancel**.



Switch between **2D / M / D** measurements.



Opens the **Subcategory** configuration.



Opens the **Application** configuration.



Save saves the changes, **Save & Exit** saves the changes and closes the configuration.

Studies

If an item in the study list is selected, the corresponding study is shown as active and measurements of the selected study are displayed. To delete a study press the delete symbol. A tap onto the study allows to rename it as desired. The keyboard appears.

Measurement buttons

The measurements available for a certain study are displayed. If a measurement is part of the **Auto Sequence**, the **Auto Sequence** symbol is added at the right upper corner. It is possible to rename a measurement as desired by tapping onto it and to add measurements by pressing +.

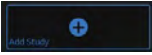
Add Study	<p>Adds a study.</p> <p>It is possible to search for available studies to be added. Enter search criteria (Application, Subcategory,...) within the search dialog and press OK to add the desired study.</p> <p>To create a new study in 2D/3D and M imaging modes enter a study name and press OK or Confirm and Add measurements. The Add Measurement dialog is opened automatically.</p> <p>To create a new study in Doppler imaging modes, enter a study name, display and report name (optional), select the study attribute (left/ right, fetus,...) and press OK or Confirm and Add measurements. The Add Measurement dialog is opened automatically.</p>
Auto Sequence	<p>Opens the Auto Sequence configuration (for Doppler measurements: the auto sequence will only be repeated immediately after a study was selected or immediately after the calculation menu was opened). It is possible to configure 1 Auto Sequence per study. An indicator is visible on each selectable measurement. As long as no Auto Sequence is selected, the indicator remains empty. As soon as an Auto Sequence is configured the indicator turns colored and displays the next available number in the Auto Sequence order. When Clear is pressed the whole Auto Sequence of the study is cleared. Repeat starts the Auto Sequence measurements again from the beginning in a loop as soon as they are finished.</p>
Change Color	<p>Opens the color selection dialog. Select the desired color and press the Change Color button again or somewhere else to close the popup window.</p>
Moving / reordering a study / measurement	<p>Grab a study and move it. Release the study to set it to the new position.</p>
Deleting a study / measurement	<p>Press the Delete symbol to delete the study / measurement.</p> <p>Note <i>It is also possible to delete a study form the active subcategory.</i></p>
Renaming a study	<p>A tap on the study name of the active study makes the study name editable. The text cursor is set into the textbox and the keyboard appears. By pressing Enter renaming is finished and the keyboard disappears.</p>
	<p>If empty space is available, the + symbol is displayed. Press + and the Add Measurements dialog appears. Select the desired criteria (Application, Subcategory,...) and choose from the measurements listed.</p>

Subcategory configuration

Press  in the header to edit the subcategories as desired. All available subcategories (max. 7) are listed.

The subcategory configuration includes:

- Adding a new subcategory by pressing **Add new subcategory**
- Removing a subcategory by pressing the **Delete** symbol
- Reordering the available subcategories (drag & drop the subcategory to the desired position)
- Renaming a subcategory by tapping onto its name and entering a new one (max. 12 characters)
- Deleting a subcategory by pressing the **Delete** symbol

Autoselect up to GA (available for OB application only): If GA is configured for subcategories and a GA is entered for the current exam, the corresponding subcategory is selected automatically when the measure menu is opened after start exam depending on the GA of the exam. If no GA of an exam is available and during the exam, the last used subcategory is selected.

Default select (available for all applications except OB): The selected subcategory is selected automatically when the measure menu is opened after start exam. During the exam, the last used subcategory is selected.

By pressing **Save** all changes are saved. **Cancel** discards the changes and closes the dialog without saving any changes.

10.2 Generic Measurements

By pressing **Calc** the Generic Measurement function is switched on (if used last before) and a cursor appears on the frozen image area. The Generic Measurement Menu is displayed and read mode is activated.

Basic operations

1. Basic operations done with the trackball
 - positioning of the measuring mark
 - entering and storing measuring marks: right/left trackball key (**Set**)
 - changing measuring marks: upper trackball key (**Change**)
2. Erasing measurement results (different possibilities)
 - **Clear** on the control panel
 - **Delete Last, Cancel** or **Clear Group** on the touchscreen
3. Exiting the Generic Measurement program
 - **Exit** on the control or touch panel

Available measurements:

- 2D Distance and Length Measurements
- 2D Area Measurements
- 2D Volume Measurements
- 2D Angle Measurements
- 3D Volume Measurements
- Elastography Measurements
- Generic M-Mode Measurements
- Generic Doppler-Mode Measurements

All measurements and calculations are based upon the primitives frequency, length and time. The measuring points in pixel coordinates are converted into primary values. Graphical measurement tools are also used to extract primary values from the ultrasound images. These values are used for measuring and calculating the desired results.

10.2.1 Generic Distance and Length Measurements

Dist. 2Point

To measure the distance between two points on a 2D image:

1. Select **Dist 2Points**. The measurement cursor appears.
2. Position the first point with the trackball and press **Set**. A second measurement cursor appears.
3. Position the second point with the trackball and press **Set** to finish the measurement.

Note *To readjust the starting point, press **Change** before completing the measurement. It alternates the control from one cursor to the other.*

Dist. 2Line

To measure the distance between two parallel lines on a 2D image:

1. Select **Dist. 2Line**. The measurement cursor appears.

2. Position the first point of the first line with the trackball and press **Set**.
3. Position the second point of the first line and press **Set**. During positioning the line is drawn.
4. Position the second line (parallel line determined through the third point) with the trackball and press **Set**. The distance between the two lines is displayed with a dotted line.

Note *To readjust the starting point, press **Change** before completing the measurement. It alternates the control from one cursor to the other.*

Length Point

This tool measures the length of a non-straight line defined by multiple points (start to end). The "length" is displayed with a dotted line, start and end point are marked with a cross like in normal distance measurement.

To measure the length point:

1. Select **Length Point**. The measurement cursor appears.
2. Position and enter point after point with the trackball and **Set** along the line.
3. To finish the length measurement enter the last point a second time by pressing **Set**.

Note *To readjust the trace, press **Undo** before completing the measurement. The trace is cleared step by step backwards.*

Length Trace

This tool measures the length of a non-straight line distance along a trace drawn with the measurement cursor. The "length" is displayed with a dotted line, start and end point are marked with a cross like in normal distance measurement.

To measure the length trace:

1. Select **Length Trace**. The measurement cursor appears.
2. Position and enter the starting point with the trackball and **Set**.
3. Trace the length boundary with the trackball and fix the end point with **Set**.

Note *To readjust the trace, press **Undo** before completing the measurement. A short press clears the trace step by step backwards, a long press clears the trace backwards until the button is released.*

Stenosis % Dist.

To measure the stenosis ratio between two distances:

1. Select **Stenosis % Dist.**. The measurement cursor appears.
2. Position the first line as described above with the trackball and press **Set**. A second measurement cursor appears.
3. Position the second line as described above with the trackball and press **Set** to finish the measurement.

Ratio D1 D2

To measure the ratio between two distances:

1. Measure the first distance as described above.
2. Measure the second distance as described above. The ratio is calculated automatically.

10.2.2 Generic Area Measurements

Ellipse

To measure the area of an ellipse:

1. Select **Ellipse**. The measurement cursor appears.
2. Position the first point of the long axis with the trackball and press **Set**.
3. Position the second point of the long axis and press **Set**.
4. Adjust the length of the short axis with the trackball and fix it with **Set**.

Note *To re-adjust the starting point, press **Change** before completing the measurement. It alternates the control from one cursor to the other.*

Area Trace

This tool measures the area inside a traced boundary. The boundary is traced when the cursor is moved over the boundary and displayed with a dotted line.

To measure the area trace:

1. Select **Area Trace**. The measurement cursor appears.
2. Position the starting point with the trackball and fix it with **Set**.
3. Trace the area boundary, which is displayed with a dotted line.
4. To finish the measurement press **Set**. The distance between the starting point and the final cursor position is completed and the area is calculated and displayed.

Note *To readjust the trace, press **Undo** before completing the measurement. A short press clears the trace step by step backwards, a long press clears the trace backwards until the button is released.*

Area Point

This tool measures the area inside a traced boundary. The boundary is entered with single points with a linear interpolation in between. The boundary is displayed with a dotted line.

To measure the area point:

1. Select **Area Point**. The measurement cursor appears.
2. Position point after point with the trackball and enter each by pressing **Set**.
3. To finish the measurement enter the last point a second time with **Set**.

Note *To readjust the trace, press **Undo** before completing the measurement. The trace is cleared step by step backwards.*

Area 2Dist.

To measure the area of an ellipse defined by two distances:

1. Select **Area 2Dist**. The measurement cursor appears.
2. Position the cursor on the perimeter of the shape to be measured and press **Set**. A second cursor appears.
3. Move the second cursor along the longest distance of the object and press **Set** again.
4. Position the second cursor perpendicular to the first distance at the border of the object to measure the second distance and press **Set** to finish.

Note *To re-adjust the starting point, press **Change** before completing the measurement. It alternates the control from one cursor to the other.*

Stenosis % Area

To calculate the stenosis ratio between two areas:

1. Select **Stenosis%Area**. The measurement cursor appears.
2. Position the first point of the long axis with the trackball and press **Set**.
3. Position the second point of the long axis and press **Set**.

4. Adjust the length of the short axis with the trackball and fix it with **Set**.

Ratio A1/A2

To calculate the ratio between two areas:

1. Select **Ratio A1/A2**.
2. Measure the first and second area as described above. The ratio is calculated automatically.

10.2.3 Generic Volume Measurements

Ellipse

To measure the volume of an ellipse:

1. Select **Ellipse**. The measurement cursor appears.
2. Position the first point of the long axis of the ellipse with the trackball and fix it with **Set**.
3. Position the second point of the long axis of the ellipse with the trackball and press **Set**.
4. Adjust the length of the short axis with the trackball and fix it with **Set**. The volume (D1: long axis, D2: short axis, MaxD: largest axis diameter, MinD: smallest axis diameter, C1: Circumference, A1: Area, VOL1: Volume) is displayed.

Note *To readjust the starting point, press **Change** before completing the measurement. It alternates the control from one cursor to the other.*

Ellipse 1Dist

To measure the volume of an ellipse with the help of a distance:

1. Select **Ellipse 1Dist**. The measurement cursor appears.
2. Position the starting point with the trackball and fix it with **Set**.
3. Position the second point with the trackball and fix it with **Set**. An ellipse defined by these two points appears.
4. Adjust the width of the ellipse if necessary and press **Set**. The result is displayed.
5. In single image mode make the first measurement.
6. Press **Freeze** to return to scan mode and scan the second image. Press **Freeze** again and a new cursor appears.
7. Perform the measurement of the distance.

Note *To readjust the starting point, press **Change** before completing the measurement. It alternates the control from one cursor to the other.*

Multiplane

This measurement program allows volume determination of any organ, which was stored as a volume scan. Several parallel planes are laid through the organ and the areas of these planes are determined.

The application calculates the volume from the measured areas and the distance between these areas. The larger the number of areas, the more exact the volume calculation result becomes.

To use Multiplane:

1. Select the reference image in which the measurement is to be performed.
2. Select **Multiplane**. The Multiplane Menu appears.
3. Select the first section through the body by pressing **Ref.slice** or by rotating the parallel shift control.

Note *The first section should be set at the edge of the measured object.*

4. Measure the area as described in Area Trace Measurement and press **Set** twice.
5. Repeat step 3 to continue measuring until the edge of the object is reached.

- Note**
- *The contour of the measured area is not erased when a new section is adjusted. From the deviation in the new section it is possible to decide whether a new area should be marked. As soon as a new contour is drawn, the old contour is erased.*
 - *To return to already measured areas select either **Prev.** or **Next.***
 - *The different sections can be chosen freely, it is not necessary to follow a certain order.*
 - *The volume measurement is only possible in 3D static mode.*
 - *To erase the results select **Init.***

1 Dist.

To measure a volume based on a single distance:

1. Select **1Dist.** The measurement cursor appears.
2. Position the starting point of the line with the trackball and press **Set**.
3. Position the end point of the line with the trackball and **Set**. The volume is displayed.

Note *To readjust the starting point, press **Change** before completing the measurement. It alternates the control from one cursor to the other.*

3 Dist.

To measure a volume based on three distances:

1. Select **3 Dist.** The measurement cursor appears.
2. Position the first point of the first distance to measure and press **Set**.
3. Position the second point of the first distance to measure and press **Set**.
4. Repeat step 2 and 3 for the second and third distance to measure. As soon as the last point is fixed with **Set** the measurement is finished.

Note *To readjust the starting point, press **Change** before completing the measurement. It alternates the control from one cursor to the other.*

10.2.4 Generic Angle Measurements

Angle 3Point

To measure the angle between two lines:

1. Select **Angle 3Point.** The measurement cursor appears.
2. Position the first point with the trackball and press **Set**.
3. Position the second point with the trackball and press **Set**. The line connecting the two points is shown.
4. Position the third point with the trackball and press **Set**. The second line is shown and the angle measured.

Note *To readjust the starting point, press **Change** before completing the measurement. It alternates the control from one cursor to the other.*

Angle2Line

To measure the angle of two lines crossing each other:

1. Select **Angle 2Line.** The measurement cursor appears.

2. Enter the first line by defining starting and end point of it.
3. Enter the second line by defining starting and end point of it. The angle is measured.

10.2.5 Generic Elasto Measurements

Note *Generic Elasto Measurements are only available when **Elasto** or **Shear Elasto** is activated and the corresponding option set.*

Elasto Single ROI

To measure the Single ROI:

1. Select **Elasto Single ROI**. The measurement cursor appears.
2. Position the first point of the circle diameter with the trackball and fix it with **Set**.
3. Position the second point of the circle diameter with the trackball and press **Set** to finish the measurement. As soon as the second point is fixed the circle trace is displayed by a dotted line.

E. Ratio Ref/ROI 1

To measure the strain of the two ROIs "Ref" and "ROI 1" and to calculate the Ratio:

1. Select **E. Ratio Ref/ROI 1**. The measurement cursor appears.
2. Define the two circles, one after the other, as described above. The result is displayed.

E. Ratio Ref/ROI 1,2

To measure the Ratio:

1. Select **E. Ratio Ref/ROI 1,2**. The measurement cursor appears.
2. Define the three circles, one after the other, as described above. The result is displayed.

E. Ratio Ref /ROI 1,2,3

To measure the Ratio:

1. Select **E. Ratio Ref/ROI 1,2,3**. The measurement cursor appears.
2. Define the circles, one after the other, as described above. The result is displayed.

10.2.6 Generic Vessel Measurements

Vessel Area

To measure the vessel area:

1. Select **Vessel Area**. The measurement cursor appears.
2. Position the starting point with the trackball and press **Set**.
3. Position the end point with the trackball and press **Set** again.
4. Adjust the width of the ellipse if necessary and press **Set**.

Note *To readjust the starting point, press **Change** before completing the measurement. It alternates the control from one cursor to the other.*

Stenosis Area

To calculate the stenosis ratio between two areas:

1. Select **Stenosis Area**. The measurement cursor appears.
2. Position the first point of the long axis with the trackball and press **Set**.
3. Position the second point of the long axis and press **Set**.

4. Adjust the length of the short axis with the trackball and fix it with **Set**.

IMT

To measure the IMT:

1. Select **IMT**. The measurement cursor appears.
2. Position the starting point with the trackball and press **Set**.
3. Position the end point with the trackball and press **Set**. The result is displayed.

Vessel Diam.

To measure the vessel diameter:

1. Select **Vessel Diam**. The measurement cursor appears.
2. Position the starting point with the trackball and press **Set**.
3. Position the end point with the trackball and press **Set** again.

Note *To readjust the starting point, press **Change** before completing the measurement. It alternates the control from one cursor to the other.*

Stenosis Diam.

To measure the diameter:

1. Select **Stenosis Diam**. The measurement cursor appears.
2. Position the starting and the end point of the line and press **Set**. The diameter is displayed.

Flow Diam.

To measure the diameter:

1. Select **Flow Diam**. The measurement cursor appears.
2. Position the starting and the end point of the line and press **Set**. The diameter is displayed.

10.2.7 Generic M-Mode Measurements

Dist. 2Point

To measure the distance between two points on an M-Mode image:

1. Select **Dist 2Point**. The measurement cursor appears.
2. Position the first point with the trackball and fix it with **Set**. A second measurement cursor appears. This one can only be moved vertically.
3. Position the second point with the trackball and fix it with **Set** to finish the measurement.

Note *To re-adjust the starting point, press **Change** before completing the measurement. It alternates the control from one cursor to the other.*

Slope

To measure the slope:

1. Select **Slope**. The measurement cursor appears.
2. Position the first point with the trackball and fix it with **Set**. A second measurement cursor appears.
3. Position the second point with the trackball and press **Set** to finish the measurement.

Note *To readjust the starting point, press **Change** before completing the measurement. It alternates the control from one cursor to the other.*

Ratio D1/D2

To calculate the ratio between two distances:

1. Measure the first distance as described above.
2. Measure the second distance as described above. The ratio is displayed automatically.

Stenosis % Dist.

To calculate the stenosis ratio between two distances:

1. Select **Stenosis % Dist.**. The measurement cursor appears.
2. Position the first point with the trackball and fix it with **Set**. A second measurement cursor appears. This one can only be moved vertically.
3. Position the second point with the trackball and fix it with **Set** to finish the measurement.

Time

To measure the time between two points on a TL (Time Line) image:

1. Select **Time**. The measurement cursor appears.
2. Position the first point with the trackball and fix it with **Set**. A second measurement cursor appears. This one can only be moved horizontally.
3. Position the second point with the trackball and press **Set** to finish the measurement.

HR

The Heart Rate is calculated from the measured time and adjusted heart rate cycles. To measure it:

1. Select **HR**. The measurement cursor appears.
2. Position the first point with the trackball and press **Set**. A second measurement cursor appears. It can only be moved horizontally.
3. Position the second point with the trackball and fix it with **Set** to finish the measurement.

IMT

To measure the IMT:

1. Select **IMT**. The measurement cursor appears.
2. Position the starting point with the trackball and press **Set**.
3. Position the end point with the trackball and press **Set**. The result is displayed.

Vessel Diameter

To measure the vessel diameter:

1. Select **Vessel Diam**. The measurement cursor appears.
2. Position the starting point with the trackball and press **Set**.
3. Position the end point with the trackball and press **Set** again.

Note *To readjust the starting point, press **Change** before completing the measurement. It alternates the control from one cursor to the other.*

Stenosis Diam.

To measure the diameter:

1. Select **Stenosis Diam**. The measurement cursor appears.
2. Position the starting and the end point of the line and press **Set**. The diameter is displayed.

10.2.8 Generic Doppler Measurements

Basic Information

- To get the best resolution and accuracy from Doppler measurements, the **Angle** correction cursor must be positioned parallel to the vessel axis (in the area of the measuring volume).
- If more measurements are performed the current measurement will be placed in the lower right corner. The previous measurements are displayed above (in successive order, like a shift register).
- Except for Auto Trace measurements, all measurement results will be automatically included in the corresponding Worksheet. To store Auto Trace measurement results, press the right or left trackball key **Set** previously.
- Depending on the selected measurement package setting and the adjustment in the Measure Setup:
 - RI and PI will be calculated using ED (End Diastole) or MD (Mid Diastole)

Note $V_{diastole} = V_{end-diastole} \text{ or } V_{min}$ (depending on this selection)

- all previously set measuring marks are erased when starting a new scan (unfreeze -> Run mode)
- the Spectral Doppler envelope curve is performed with a continuous trace line or by setting points
- the Doppler measuring results (according to the "Auto/Manual Trace" setting) are displayed after an Auto- or Manual Trace measurement (Setting will be ignored in Cardiac calculations).
- measurement items (e.g., BPD) will be shown with or without the Author's Name.
- Depending on the setting in the Measure Setup:
 - all previously set measuring marks are erased when activating cine mode.
 - a new cursor appears to repeat the measurement, or not
 - the caliper (the last measuring mark of the current measurement) is fixed when pressing the **Freeze** key, the **Print A** or **Print B** keys, **Save** key, etc., or not

Moreover, many display properties depend on the setting in the Measure Setup.

Vel.

To measure the velocity:

1. Select **Vel.**. The measurement cursor and a horizontal line "hanging" on the cursor appear.
2. Position the velocity point and fix it with **Set**. The measurement is finished and **Vel.** is switched off.

AutoTrace

To measure the AutoTrace:

1. Select **Auto Trace** to start the trace calculation. It traces the Doppler spectrum automatically and displays the results.
2. Edit the trace if necessary (adjust sensitivity, trace mode, angle, starting/End point).
3. Accept the result (Peak Systolic/Diastolic Velocity, Min./End/Mean Diastolic Velocity, Velocity Time Integral, TAm_{ean}) . The measurement is finished and **Auto Trace** is switched off.

Manual Trace

To use this manual trace tool:

1. Select **Manual Trace**. The measurement cursor appears.
2. Position the starting point and fix it with **Set**.
3. Trace the envelope boundary and enter the end point to finish the measurement. The values (Peak Systolic/Diastolic Velocity, Min./End/Mean Diastolic Velocity, Velocity Time Integral, Heart Rate, Slope, Pressure Gradient Mean, Time, T_Amean, PeakA) are calculated and displayed.

Accel.

To measure the acceleration:

1. Select **Accel**. The measurement cursor appears.
2. Position the first point with the trackball and press **Set**. A second cursor appears.
3. Position the second point of the measurement and press **Set**.

Note *To readjust the starting point, press **Change** before completing the measurement. It alternates the control from one cursor to the other.*

PS/ED Velocity Ratio

To calculate the Peak Systolic Velocity and the End Diastolic Velocity Ratio:

1. Select **PS/ED**. The measurement cursor appears.
2. Move the cursor to the peak systolic velocity and press **Set**. A second cursor appears.
3. Position the second cursor at the end diastolic velocity and press **Set**.

RI (Resistance Index)

To measure the RI:

1. Select **RI**. The measurement cursor appears.
2. Move the cursor to the peak systolic velocity and press **Set**. A second cursor appears.
3. Move the second cursor to the end diastolic velocity and press **Set**.

PI (Pulsatility Index)

To measure the PI:

1. Select **PI**. The measurement cursor appears.
2. Move the cursor to the start of the measurement and press **Set**.
3. Trace the curve.
4. Move the second cursor to the end of the measurement and press **Set**.

Note *To readjust the traced line press **Undo** repeatedly.*

PG (Pressure Gradient) Measurements: PG mean/PG max

To measure PGmax:

1. Select **PGmax** on the touch panel. The measurement cursor appears.
2. Move the cursor to the pressure gradient point and press **Set** to fix the marker.

To measure PGmean:

1. Select **PGmean** on the touch panel. The measurement cursor appears on the screen.
2. Move the cursor to the beginning of the waveform (V_{max}) and press **Set** to fix the marker.
3. Trace to the end of the waveform and press **Set** again.

Note *To readjust the traced line press **Undo** repeatedly.*

Time

To measure the time between two points on a TL (Time Line) image:

1. Select **Time**. The measurement cursor appears.
2. Position the first point with the trackball and fix it with **Set**. A second measurement cursor appears. This one can only be moved horizontally.
3. Position the second point with the trackball and press **Set** to finish the measurement.

HR

The Heart Rate is calculated from the measured time and adjusted heart rate cycles. To measure it:

1. Select **HR**. The measurement cursor appears.
2. Position the first point with the trackball and press **Set**. A second measurement cursor appears. It can only be moved horizontally.
3. Position the second point with the trackball and fix it with **Set** to finish the measurement.

10.3 Additional Measure Tools

Double Distance (Perpendicular)

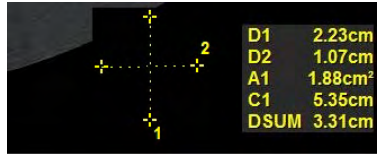

To measure the perpendicular distance to another distance:

1. Select the double distance measurement. The cursor appears.
2. Position first point of distance 1 with the trackball and press **Set**.
3. Position the second point of distance 1 with the trackball and press **Set**.
4. Position the first point of distance 2 with the trackball and press **Set**. The second measure cursor appears.
5. Position the second point of distance 2 with the trackball and press **Set**. The result is displayed.

Hipjoint



To measure the hipjoint:

1. Select the measurement. The cursor appears.
2. Enter line 1 by positioning point 1 and 2.
3. Enter line 2 by positioning point 3 and 4.
4. Enter line 3 by positioning point 5 and 6. The result is displayed.

Vol Simpson

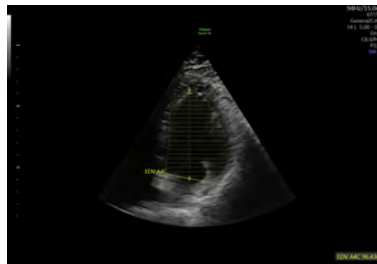

To measure the volume with the Simpson method:

1. Select the measurement. the cursor appears.
2. Position a start point with the trackball and press **Set**.
3. Position the end point of the trace and press **Set**. The trace area is displayed with a dotted line.
4. The area diameters and corresponding volumes are displayed according to the Simpson method.

LV Study

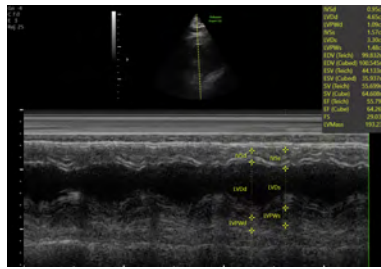

To measure LV:

1. Select the measurement. The vertical diastolic line and the cursor appear.
2. Position the vertical line on the diastolic position.
3. Enter the first, second, third and fourth point on the diastolic line.
4. Position the second vertical line on the systolic position.
5. Enter the first, second, third and fourth point on the systolic line.

MV Study

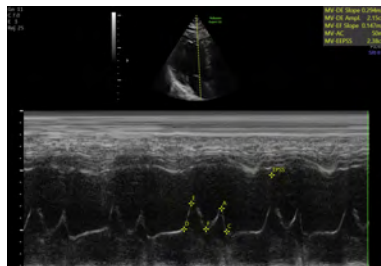

To measure MV:

1. Select the measurement. The cursor appears.
2. Position point D, E, F, A, C and EPSS sequentially. After the last point is set the measurement is finished.

PHT

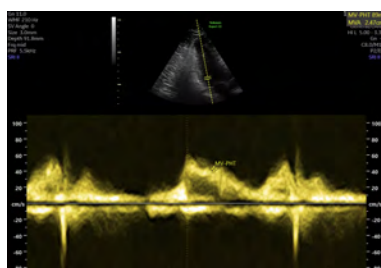

To measure PHT:

1. Select the measurement. The cursor appears.
2. Position P_1 with the trackball and press **Set**.
3. Position P_2 with the trackball and press **Set**. The result is displayed.

PISA Trace

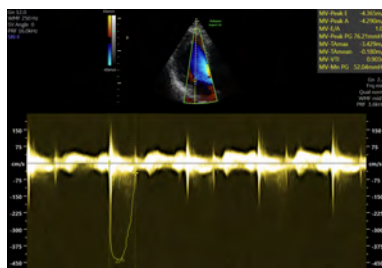

To measure the PISA Trace:

1. Select the measurement. The cursor appears.
2. Position the center start point P1.
3. Draw the PISA trace and enter the end point P2. The result is displayed.

Stress / rest sequence

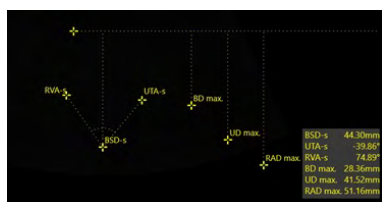

To measure the stress sequence:

1. Select the measurement. The cursor appears.
2. Position the horizontal reference line and press **Set**.
3. Position the endpoint of the first distance measurement (BSD-s). The start point is positioned automatically. The set endpoint is the start point of the first angle measurement.
4. Position the endpoint of the first (UTA-s) and second angle measurement (RVA-s).
5. Position the endpoint of the second distance measurement (BD max). The start point is positioned automatically.
6. Position the endpoint of the third (UD max) and fourth distance measurement (RAD max). The start point is positioned automatically on the reference line.

Note

The following measurements are displayed as negative numbers when they are performed from the reference line in direction to the probe surface and as positive numbers when they are performed starting from the reference line leading away from the probe surface:

- BSD-s
- BD max
- UD max
- RAD max

Note

If BD, UD and RAD are part of the sequence depends on the selection in the measure setup.

To measure the rest sequence:

1. Select the measurement. The cursor appears.
2. Position the horizontal reference line and press **Set**.
3. Position the endpoint of the distance measurement (BSD-r). The start point is positioned automatically. The set endpoint is the start point of the first angle measurement.

4. Position the second (UTA-r) and third point (RVA_r) of the angle measurement.
5. Position the end-point of the 2nd (BD max.), 3rd (UD max) and 4th (RAD max) distance measurement . The start-point is positioned on the reference line automatically.

Note *The following measurement is displayed as negative numbers when it is performed from the reference line in direction to the probe surface and as positive numbers when it is performed starting from the reference line leading away from the probe surface:*

- BSD-r

Note *If BD, UD and RAD are part of the sequence depends on the selection in the measure setup.*

Pelvic Floor



To measure the Levator Hiatus:

1. Select the measurement. The cursor appears.
2. Position the cursor and press **Set Area** to fix the start point of the Levator Hiatus measurement.
3. Draw the trace with the trackball. Press **Undo** to remove the last part of the trace or **Edit Area** to change the trace if needed.
4. Press **Set Area** to finish the measurement.
5. Position the cursor and press **Set AP** to fix the start point of the LH AP Diam measurement, then position the cursor and press **Set AP** to fix the end point of the LH AP Diam measurement. Press **Change** to switch the focus of the start and end point or press **Edit Area** to edit the Levator Hiatus measurement.
6. Position the cursor and press **Set Lat** to fix the start point of the LH Lat Diam measurement, then position the cursor and press **Accept** to fix the end point of the LH Lat Diam measurement or press **Edit Area** to edit the Levator Hiatus measurement and afterwards **Edit AP** to edit the LH AP Diam measurement

2D Angle Distance

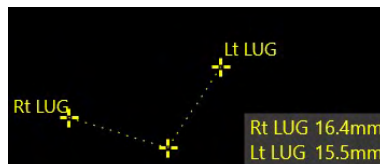

To measure the 2D Angle Distance:

1. Select the measurement. The cursor appears.
2. Position point 1 with the trackball and press **Set**.
3. Position point 2 with the trackball and press **Set**. Line 1 is displayed/refreshed while positioning point 2.
4. Position point 3 with the trackball and press **Set**. Line 2 is displayed/refreshed while positioning point 3.

10.4 Calculations

The measurement packages allow measurements/calculations in 2D/3D Mode, M-Mode and Doppler-Mode using most commonly used measure items (i.e. Fetal Biometry: BPD, HC, AC, FL,...). These factory presets defined by the most commonly used items can be customized by the user and adjusted in the system setup.

1. Press the **Patient** hard key on the control panel.

Note *To cancel all calculations performed before and to start a new measurement, press the **Patient** hard key and select **End Exam** or **Clear Exam**.*

2. Select the proper exam and enter all patient information necessary for the selected exam type.
3. Press **Start Exam**.

OB Calculations

2D/3D Mode:	<ul style="list-style-type: none"> • Biometry (Fetal Biometry, Early Gestation, Lung, Long Bones, Fetal Cranium, AFI, Uterus, Ovary, Ovarian, Umbilical Vein, Uterine, EFW, Fractional Limb Vol., Placenta, Cerebellar Vermis) • Z-Scores (Long Axis, Aortic Arch, Short Axis, Obl. Short Axis, 4 Chambers) • Fetal Echo (Chambers, Thorax, Aorta/LVOT, Pulmonary/RVOT, Venous) • Nuchal Translucency • Intracranial Translucency
M Mode:	<ul style="list-style-type: none"> • Biometry (Generic, FHR, Atrial FHR) • Fetal Echo (Chambers, Aorta/LVOT, Pulmonary/RVOT, FHR) • Z-Score
Doppler Mode:	<ul style="list-style-type: none"> • Biometry (Ductus Art., Ductus Ven., Ao, Left/right Carotid, Left/Right MCA, Umbilical Art., SMA, Left/Right Uterine Art., FHR, Celiac Art., Left/Right UMA, IVC) • Fetal Echo (Mitral Valve, Tricuspid Valve, Aortic, Pulmonary, LPA, RPA, Ductus Art., Cardiac Output, FHR, RVOT Rt TEI, LVOT Lt TEI, Ductus ven., Umbilical Vein, Pulmonary Veins, PR Interval)

TR Calculations

2D/3D Mode:	Prostate, Vessel
M Mode:	no factory presets
Doppler Mode:	no factory presets

Small Part Calculations

2D/3D Mode:	Thyroid, Testicle, Vessel, Dor. Pen.A., Breast Lesion #1-5
M Mode:	Vessel, Dor. Pen. A, Breast (Vessel)
Doppler Mode:	Vessel, Dor. Pen. A., Breast (Vessel)

Cardio Calculations

2D/3D Mode:	LV Simpson (Single), Volume A/L (<i>Volume Area/Length</i>), LV-Mass (Epi & Endo Area, LV Length), LV (RVD, IVS, LVD, LVPW), LVOT Diameter, RVOT Diameter, MV (Dist A, Dist B, Area), TV (Diameter), AV/LA (Aortic Valve & Left Atrium Diameter), PV (Diameter)
M Mode:	LV, AV/LA, MV, HR, TV
Doppler Mode:	MV, AV, LVOT, TV, PV, RVOT, Pulmonary Veins, PAP, HR, RAP, TEI Index

ABDO Calculations

2D/3D Mode:	Liver, Gallbladder, Pancreas, Spleen, Kidney, Renal Artery, Aorta, Vessel, Port. V., Bladder
M Mode:	Renal Artery, Aorta, Vessel
Doppler Mode:	Renal Artery, Aorta, Vessel, Portal Vein

Gyn Calculations

2D/3D Mode:	Uterus, Uterine, Ovary, Follicle, Fibroid, Pelvic Floor, Early Gestation, Ovarian Cyst, Ovarian Mass, Adnexal Cyst, Generic Cyst, Adnexal Mass, Generic Mass, Bladder, Cervix, Myoma, Endometrium
M Mode:	Ovarian, Uterine, FHR
Doppler Mode:	Ovarian, Uterine, Vessel, FHR

VASC Calculations

2D/3D Mode:	Left/Right CCA (<i>Common Carotid Artery</i>), Left/Right ECA (<i>External Carotid Artery</i>), Left/Right ICA (<i>Internal Carotid Artery</i>), Left/Right Bulb, Left/Right Vertebral Artery, Left/Right Subclavian Artery, Vessel
M Mode:	Left/Right CCA, Left/Right ECA, Left/Right ICA, Left/Right Bulb, Left/Right Vertebral Artery, Left/Right Subclavian Artery, Vessel
Doppler Mode:	Left/Right CCA, Left/Right ECA, Left/Right ICA, Left/Right Bulb, Left/Right Vertebral Artery, Left/Right Subclavian Artery, Vessel

PED Calculations

2D/3D Mode:	Left/Right HIP, Left/Right Perical Artery
M Mode:	Left/Right Perical Artery
Doppler Mode:	Left/Right Perical Artery

CEPH Calculations

2D/3D Mode:	Left/Right ACA (<i>Anterior Cerebral Artery</i>), Left/Right MCA (<i>Middle Cerebral Artery</i>), Left/Right PCA (<i>Posterior Cerebral Artery</i>), Basilar Artery, A-Com A. (<i>Anterior Common Artery</i>), Left/Right P-Com A. (<i>Posterior Common Artery</i>), Left/Right CCA (<i>Common Carotid Artery</i>), Left/Right ICA (<i>Internal Carotid Artery</i>), Left/Right Vertebral Artery, Vessel
M Mode:	Left/Right ACA, Left/Right MCA, Left/Right PCA, Basilar Artery, A-Com A., Left/Right P-Com A., Left/Right CCA, Left/Right ICA, Left/Right Vertebral Artery, Vessel
Doppler Mode:	Left/Right ACA, Left/Right MCA, Left/Right PCA, Basilar Artery, A-Com A., Left/Right P-Com A., Left/Right CCA, Left/Right ICA, Left/Right Vertebral Artery, Vessel

MSK Calculations

2D/3D Mode:	no factory presets specified
M Mode:	no factory presets specified
Doppler Mode:	no factory presets specified

10.4.1 Additional Calculations

Some measurements are specific to the Voluson systems. Nevertheless they can be adjusted and customized in the system setup.

10.4.1.1 GS (Gestational Sac)

There are two methods to measure the GS:

1. Three distance measurement (mean value = GS diameter)
2. One distance measurement (value = GS diameter)

Method 1

The three distance measurement requires three measurements (length, width, height) before the age is displayed. The age is derived from the mean value of all three measurements.

The workflow is identical to the measurement "3 Dist".

Method 2

One distance measurement is required before the age is displayed. The age is derived from the distance measurement.

To use this method:

1. Select GS. A cursor appears.
2. Measure the GS distance like a normal distance measurement. The result is displayed immediately.

10.4.1.2 Sono NT (Nuchal Translucency)

Note *This measurement can be adjusted and customized in the system setup.*

To measure the contour detection of the NT border:

1. Select **NT**. The measurement cursor appears.
2. Select the fetal position ("Face Up" or "Face Down").
3. Position and fix the first point P1 of the rectangular ROI.
4. Position and enter the second point P2 of the rectangular ROI. The NT border detection is performed. If a valid result is found, the borders are shown in red and the NT distance is displayed with two crosses.
5. Only if the found measurement is correct according to the guidelines, accept and confirm the result. Then it will be stored in the report. If the system cannot detect a result, an important information appears.

Note *To edit the measurement move the trackball and/or press **Change** to readjust the start and end point before accepting the measurement.*

Note *If the current US image magnification is too low (the corresponding pixel size is bigger than 0.1mm), a magnification hint is displayed if activated in the system setup. When this hint appears, increase the magnification and redo the measurement.*

Note *It is possible to select the calculation method by pressing **Method**: (i-i: inner-inner or i-m: inner-middle).*

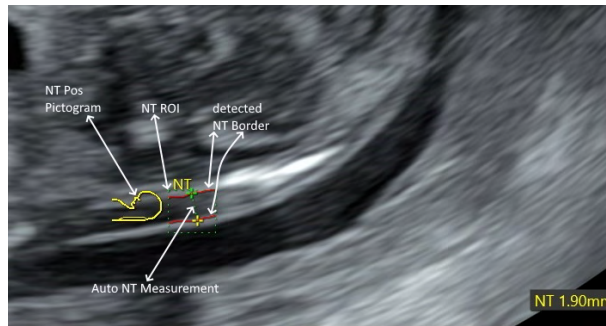

Figure 10-3 Display of the Sono NT analysis (sample)

IT (Intracranial Translucency)

SonoIT (Sonography based Intracranial Translucency) is a system supported measurement for Intracranial Translucency. Starting from the routinely used midsagittal view of the fetal face, obtained for assessment of the Nuchal Translucency and nasal bone, the ultrasound system uses a semi-automated mode to measure the anterior-posterior diameter of the fourth ventricle recognizable as intracranial translucency.

The workflow is identical with SonoNT.

10.4.1.3 Fractional Limb Volume

This group of measurements is used to detect fetal growth restrictions by means of calculating partial volumes of the upper or lower limbs. The result allows fetal weight estimation by comparing it with standard tables.

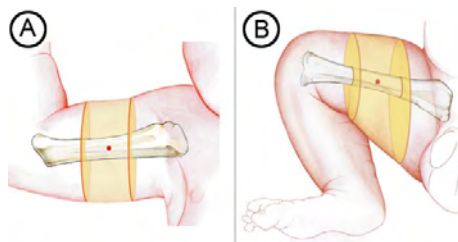
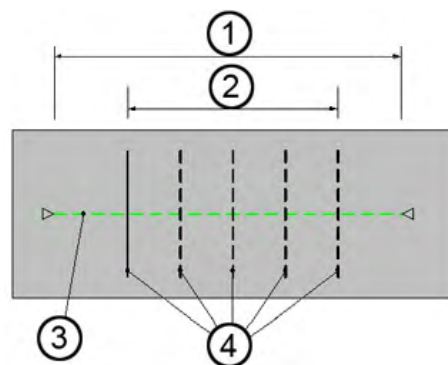

Figure: Fractional limb volume. Fractional Arm (AVol) and Thigh (TVol) volumes are based on 50% of the humeral (A) or femoral (B) diaphysis length. Mid-limb measurements eliminates the need for tracing soft tissue borders near the ends of the bone shaft, where acoustic shadowing is more likely to be encountered.

Method: The slice positions are determined depending on the reference distance line, the slice number and the percentage of limb and displayed graphically on screen. The volume is calculated after the area measurements are done on the slices.



1.	100% Limb length (reference length)	3.	Reference distance line
2.	Region of interest used for analysis	4.	Equidistant Slice positions (start/end depend on region of interest)

Number of slices: fixed to 5

Region of interest (percentage of limb): fixed to 50%

To measure the fractional limb:

1. Select **Fract Limb** in Biometry in the OB Application Menu. The fractional limb measure items appear.
2. Select the corresponding fetus # if necessary.
3. Select **A Vol** or **T Vol**. The Fractional Limb edit menu appears on the touchscreen.
4. Define the reference line using the trackball and press **Set**.
5. Measure all the areas. As soon as one measurement is done the next line is highlighted.

Note *To correct measurements select the slices one by one with **Prev** or **Next**.*

6. Press **Done** to finish the measurement.

10.4.1.4 SonoBiometry



Caution

SonoBiometry measurements are intended for use with gestational ages between 18 and 25 weeks only: Cereb, CM, Vp.

SonoBiometry is an alternative to the common fetal biometry measurements. It provides system suggested measurements for BPD, HC, AC, FL, CM, Cereb, Vp and HL which need to be confirmed by the user or can be changed manually.

The acquired image has to contain the entire anatomical structure required for the measurement and the anatomical structure should take up the majority of the space on the image.

To use :

1. Press **Calc** on the user interface.
2. Select the measurement package **OB**.
3. Select the desired measurement item (**BPD, HC, AC, FL, CM, Cereb, Vp** or **HL**).
4. The calculation process starts. The result is displayed on the monitor screen. If the result is not correct, proceed with manual correction by pressing **Change** or moving the trackball cursor.
5. Press **Set** to accept the result and to finish the measurement.

Note *It is possible to select between **Manual** and **Auto**. A tap onto the desired value displayed activates it. The selected value is displayed on the button.*

10.4.1.5 Facial Angle Measurement

Two facial angle measurements are available:

- **FMF Angle (Frontomaxillary Facial Angle):** The FMF angle is measured between a line along the upper surface of the palate and the upper corner of the anterior aspect of the maxilla, extending to the external surface of the forehead, represented by the frontal bones or an echogenic line under the skin below the metopic suture that remains open.
- **MMF Angle (Mandibulomaxillary Facial Angle):** The MMF angle is generated by using the same first part and the same apex as for the FMF angle. The second part, however, is drawn downwards and positioned so that the inner aspect of the line flushes with the upper anterior corner of the mandible.

Note *The Facial Angle measurements are not included in the presets but need to be added manually to a measurement group.*



Figure 10-4 Monitor display: Fetal Facial Angle measurement

10.4.1.6 SonoFHR

SonoFHR is a workflow feature which presets the heart rate measurement caliper automatically based on the PW-/CW-/M-Mode image data. The user can adjust manually or accept the preset placed calipers.

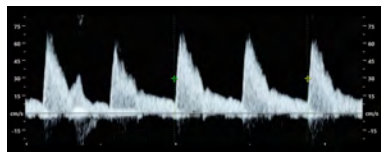

To measure SonoFHR:

1. Select the measurement. The cursor is positioned automatically. The range of the measurement depends on the set number of HR cycles.
2. Position the HR measurement with the trackball and press **Set**.

10.4.2 Additional Information

Display of 2D Measurements

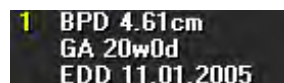

BPD: Type of Measurement GA: Gestational Age EDD: Estimated Date of Delivery

Note "GA=OOR" means that the "Gestational Age is Out Of Range" - no standard curve available for current input.

Note EDD (Estimated Day of Delivery) is only displayed, if the selection of the field "Show EDD calc. on screen" in the Measure Setup is "Yes".

There are 3 possibilities to display 2D Measurement results:

1.

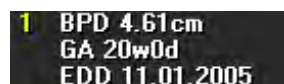

no clinical GA available **no growth percentile (%) or standard deviation (SD) display**

2.

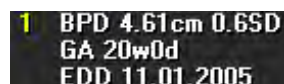

Display of the Standard Deviation (e.g., 0.6SD)

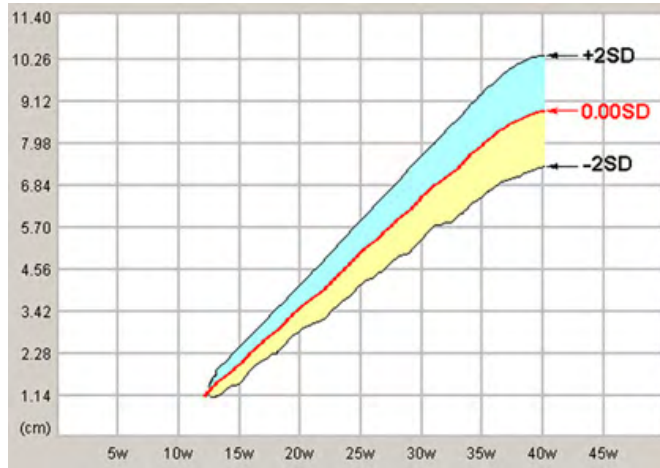

e.g.	Mean:	. SD
	Min./Max.:	-2SD / +2SD
	out of range:	< SD / > SD

Note Selection of the field “Growth Dev. Display” in the Measure Setup is “SD”.

3.

1 BPD 4.61cm 71.9%
GA 20w0d
EDD 11.01.2005

Display of the growth percentile (e.g., 71.9%)

e.g.	Mean:	50%
	Min./Max.:	5.% / 95.%
	out of range:	<5.% / >95.%

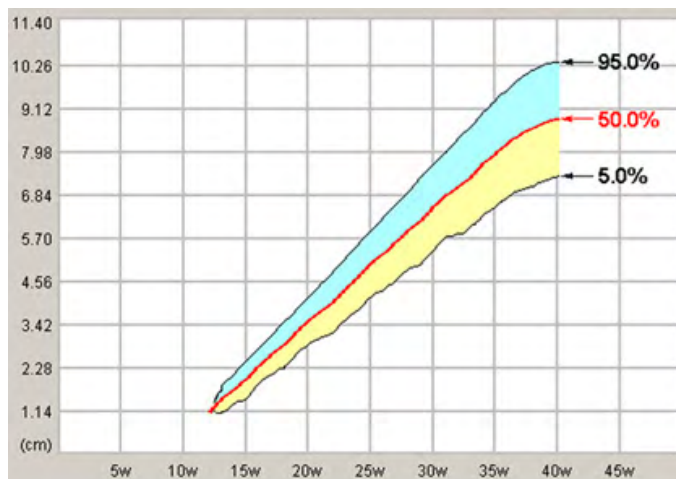

Note Selection of the field “Growth Dev. Display” in the Measure Setup is “%”.

Z-Scores

The Z-scores compare either GA, BPD or FL with any fetal echo parameter (i.e.: Aortic valve, RV area, LV area). So in order to obtain Z-scores on your report, you either need to measure BPD or FL, or have the GA calculated from your LMP; and measure any parameter from fetal echo. To obtain Z-scores use measurements from the subcategory Z-scores.

Note As LV area and RV area are the biggest parameters, they are the parameters of your choice to keep measurement inaccuracies at minimum level.

The Z-scores will be displayed on the worksheet.

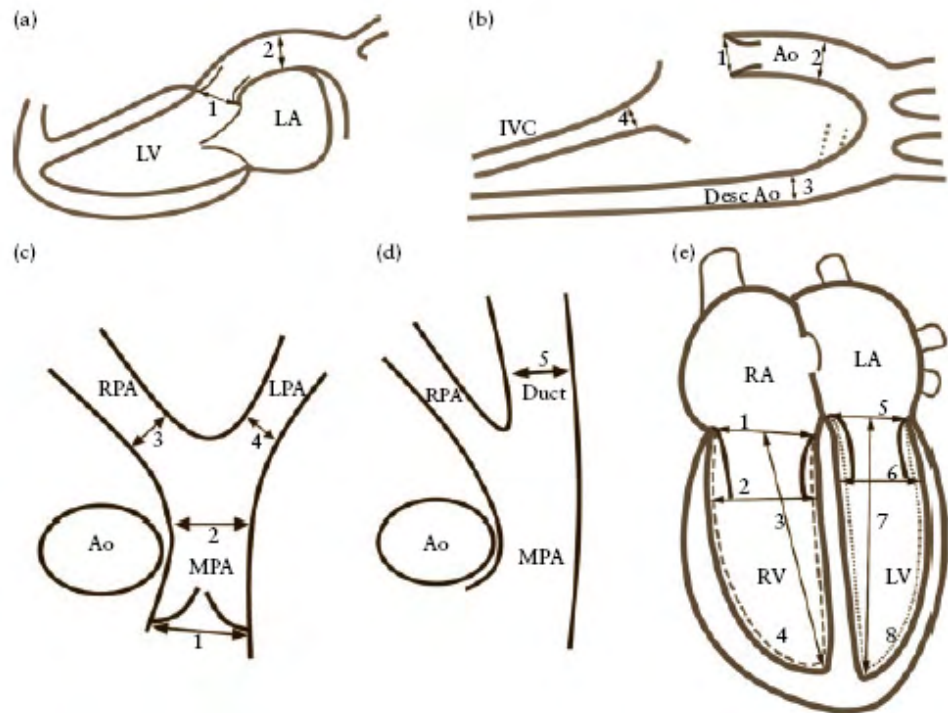

Fetal echocardiographic views from which the cardiac structures can be measured: **(a)** Long Axis view of the left ventricle showing the aortic valve (1) and ascending aorta (2). **(b)** Aortic arch view showing the aortic valve (1), ascending aorta (2), descending aorta (3) and inferior vena cava (4). **(c)** Short axis view showing the pulmonary valve (1), main (2), right (3) and left (4) pulmonary arteries. **(d)** Oblique short axis view, showing the pulmonary trunk and arterial duct (5). **(e)** Four chamber view, showing the tricuspid valve (1), right ventricular end-diastolic dimension (2), right ventricular inlet length (3), right ventricular area (dashed line) (4), mitral valve (5), left ventricular end-diastolic dimension (6), left ventricular inlet length (7) and left ventricular area (dotted line) (8). Ao, aorta; Desc Ao, descending aorta; IVC, inferior vena cava; LA, left atrium; LPA, left pulmonary artery; LV, left ventricle; MPA main pulmonary artery; RA right atrium; RPA, right pulmonary artery; RV right ventricle.

REFERENCE: Schneider C. et. al., "Development of Z-scores for fetal cardiac dimensions from echocardiography", *Ultrasound Obstet Gynecol.* Vol. 26, 2005, pages 599-605.

Fomulas:

$$Z\text{-scores} = (\ln(\text{actual}) - \ln(\text{predicted cardiac dimensions})) / \text{Root MSE}$$

$$\ln(\text{predicted cardiac dimensions}) = m \cdot \ln(\text{FL, GA or BPD}) + c$$

FL...femur length; GA...gestational age in completed weeks; BPD...biparietal diameter; m...multiplier; c...intercept

Note For further details please consult the ARM.

Note Some measurements and calculations may not be available in all countries.

10.5 Worksheet/Report

All calculation results are recorded in the application dependent patient worksheets. By pressing **Report** on the control panel or touching **Report** in the Calculation menu, the Worksheet of the selected Measurement Application is switched on. (Always starts with the first page of worksheet.) According to the selected measurement application the worksheets display the results of the calculations, graphs, growth percentile bars and application dependent information available.

To close the worksheet press **Exit** on the touch panel.

Note *It is now possible to switch between Gyn and OB worksheets (if both worksheets exist).*

Note *Display depends on the selected measurement package.*

Note *If a patient worksheet contains measurements that were performed in the XTD-View mode ('Extended View (XTD-View)' on page 6-20), a yellow caution symbol will be shown in the worksheet header.*

Note *If the measurement result is outside the visible range of a graph, an arrow indicates that the "x" is off the charts.*

Note *If the DICOM Configuration STR.REPORT (Structured Report) is set up, previous exams can be retrieved from a QR Server using **Retrieve Trend Data** and are then added to the archive. DICOM Retrieval of measure data from past exams includes originally transferred data only. Any changes made after transfer cannot be retrieved.*

Worksheet/Report Menu

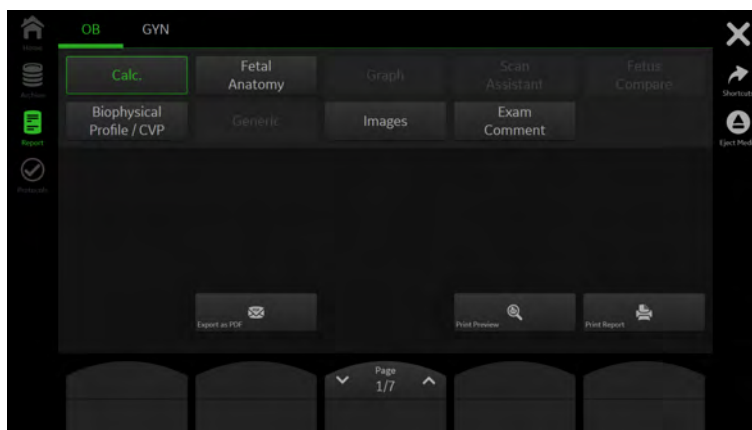

Figure 10-5 OB Worksheet (example)

Worksheets	Select the desired Worksheet (i.e. Calc. , Gyn Findings , IOTA ,.....) and how to display the Graph Worksheet (if selected: Bar , Single , Quad).
Transfer Data	Press Transfer Data to send the report to a remote report server.
Export as PDF	Save the report as a .pdf file.
Email Report	Press Email Report to send the report .pdf file via email.
Print Preview	Displays the print preview dialog.
Print	Prints the report according to the print preview settings.
Fetus	Select the desired fetus (only available if more than one fetus exists).
Page	Switch to the previous/next page (if available).
Exit	Exits the report menu.

Editing a Worksheet/Report

Any stored measurements in a patient worksheet can be edited. Move the cursor to the desired field, press **Set** and type in the changes. The edited values are marked with an asterisk (* next to the changed value). Additionally some parameters or settings can be changed by clicking into the specific field on the worklist page. For example: **Method**: average (all values + or - or average for + and - values mixed), minimum, maximum, last or off.

Changing the Measurement Package

1. To change the measurement package press **Meas Applicat.**.
2. Select the desired measurement package and press **Return**.

Exam Comment

Touch **Exam Comment** to enter up to 20 comments and save them with a title desired by pressing **Save as**. Up to 5 comment buttons are available. If pressed, the saved comments are added to the comment box on the screen.

If more than 5 comments were saved, press **More Comments** to view a dropdown list with all entered comments. Select **Manage Comments** to open the **Manage Comments** dialog (move comments up or down, delete comments,...).

To delete all entered comments, touch the **Clear** key on the touch panel.

Transferring a Worksheet

Press **Transfer Data** to transfer the patient worksheet data to the selected destination.

Note *If a Structured Report Server exists, the data is transferred using DICOM Structured Reporting, independent of whether there are other report servers (network, serial) available.*

Note *The **Transfer Data** key can only be selected if a "Service: REPORT" destination is specified in the System Setup; To specify a DICOM Address: 'DICOM' on page 11-23*

Note ***Receiving Report Data** An example for software that can receive and store reports is the "PIA" documentation system for medical diagnostics and digital image archiving from "ViewPoint": (www.gehealthcare.com/viewpoint)*

Printing a Report

1. Press **Print Preview** to see how the selected content will appear on the report. The preview can be customized:
 - 1.1. Select the desired measurement package.
 - 1.2. Select a **Report Format: Standard, Compact A or Compact B**.

Info ***Compact A and Compact B** are only available if the check box **Use Compact Format** is checked in the Measure Setup.*

 - 1.3. Select the preview page to be displayed using the respective control below the touch panel.
 - 1.4. Enlarge or reduce the size of the preview by pressing **Zoom In** or **Zoom Out** if desired.
 - 1.5. Print the Report: Under **Print Report(s)** select if the Report should be printed either for the selected measurement package or for all packages.
 - 1.6. Press **Exit** to close the **Report Preview** without printing.
2. Press **Print Report** to print the report.

Saving data as PDF

1. Select **Save as PDF**.
2. The Export Dialog is displayed.
3. An automatic file name will be generated.
4. Choose a location to save the file to.
5. The Report will be saved as a PDF file.

Images in the Worksheet

Configuring a P-Button to save images to the Worksheet:

1. Press **Util.** on the user interface.
2. Select **System Setup** on the touch panel.
3. Select **Connectivity**.
4. Select the **Button Configuration** tab.
5. Choose a P-Button and check **Save to Worksheet with P**.
6. Save and exit.
A symbol is displayed on the monitor next to the corresponding P-Button.

Adding an image from the Clipboard to the Worksheet:

1. Press **Report** on the user interface.
2. Select the button **Images** on the touch panel.
A check mark icon is displayed next to each image on the Clipboard. If checked the image will be added to the Worksheet.
3. Move the mouse over an image in the clipboard and use the small trackball buttons **Add/Remove** to add or remove images to/from the Worksheet. Or check or uncheck the icon next to the image displayed on the monitor by pressing the trackball button **Set**.

Adding an image from the Archive to the Worksheet:

1. Press **Review** on the user interface to open the Archive.
2. Press **Exam Review** on the touch panel.
3. Select individual images by checking the icon next to an image or press **Select all images** and then press **Add to Worksheet**.

10.5.1 Graph Worksheet



Figure 10-6 Graph Worksheet (example)

Displays available graphs and measurements (i.e. **Lt** and **Rt** values, **MoM** values,...).

Controls

Print	Displays a list of all available measured and graph compatible items. Check the items to be printed.
Current	Displays the following details: <ul style="list-style-type: none"> ● GA (AUA) or GA () ● EFW ● GA
History	Displays older exams (only if available). Old measure results are displayed depending on the selected graph item.
Printer Format	Choose the desired printer format: <ul style="list-style-type: none"> ● 6 graphs per page ● 2 graphs per page ● 1 big graph and 4 small graphs per page
GA Reference	Switch between GA (AUA) and GA (LMP) .
Plot	Select between Current and Trend .
Fetus Compare	If activated a separate cross for each fetus is displayed.
Retrieve Trend Data	When a DICOM SR Configuration is available all older exams are retrieved from a QR server and added to the archive.

10.5.2 Fetal Anatomy Worksheet



Figure 10-7 Fetal Anatomy Worksheet

The content of the **Fetal Anatomy** Worksheet depends on the selected measure presets (**Extended, General, Basic**). Select and adjust the settings as you prefer (i.e. **Head/ Neck, Face**,...). If a worksheet of a previous exam is opened, the content of this Fetal Anatomy exam is displayed.

Fill Default fills in all items configured in the measure setup as well as all configured default values. **Clear** clears all values.

Note When the worksheet gets printed, the results are displayed in 2 columns.

10.5.3 Findings Worksheet

Select **GYN** in the Worksheet/Report menu and press **Findings** to display the Findings Worksheet.

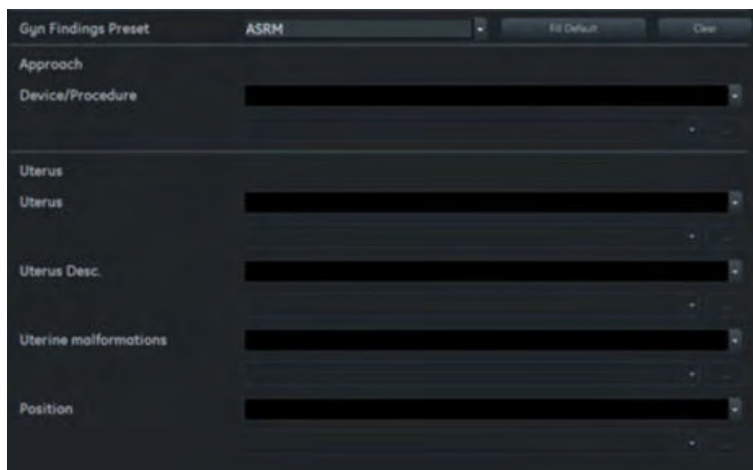

Figure 10-8 Findings Worksheet

The content of the **Findings** worksheet depends on the on the selected measure configuration. Select and adjust the settings as you prefer (i.e. **Uterus, Position**,...) by selecting the desired items from the dropdown lists available. Multiselection is possible for several items, all selected items are then marked with a check in the checkbox. In addition it is possible to enter comments/descriptions.

Fill Default fills in all items configured in the measure setup as well as all configured default values. **Clear** clears all values.

10.5.4 IETA Worksheet

Select **GYN** in the Worksheet/Report menu to display the IETA Worksheet if the option is set.

Two IETA models are available:

- IETA - Unenhanced ultrasound examination
- IETA - Enhanced ultrasound examination: Sonohysterography

Figure 10-9 IETA - Unenhanced ultrasound examination

Figure 10-10 IETA - Enhanced ultrasound examination: Sonohysterography

Select the desired items from the dropdown menus by clicking onto the arrow. The selected items are added to the corresponding box. A second click on a selected item deselects it again.

10.5.5 IOTA LR2 Worksheet

Note IOTA LR2 Calculation is an option.

Note IOTA LR2 Calculation may not be available in all countries.

The IOTA (International Ovarian Tumor Analysis) LR2 Worksheet contains an ovary measurement tool for women with adnexal tumors that have been selected to undergo surgery. The LR2 model is based on published literature and has been tested only on the stated population. The literature states that

the LR2 model can help to estimate the probability of an adnexal mass of being malignant. The IOTA group has evaluated other ways including an LR1 model in addition to the LR2 model.

Note *IOTA states that use outside of the intended population can over- or underestimate risk. Users are expected to study the literature and reach their own professional conclusions regarding the clinical utility of the tool. The model cannot replace experience in ultrasonography and cannot compensate for equipment that may be uncalibrated or otherwise in need of service/repair.*

The IOTA mathematical logistic regression model, LR2 is stated in literature as described in the Advanced Reference Manual

GE HealthCare is passing on this IOTA LR2 worksheet for your convenience based on published literature of one group, but makes no representation of its effectiveness in your practice. This calculation is not to be used as the primary driver in diagnostic decision making on the probability of malignancy. It is secondary information for a physician to use based on recent literature.

Workflow

1. Select IOTA LR2 Model on the Gynecology Worksheet touch panel.
2. Patient name and ID are entered by the system.
3. Fill in items 1 to 6. The Patient's age is entered by the system if available from the Patient Information Dialog.
4. The IOTA LR2 model result is displayed.

Note *A yellow warning symbol will be displayed.*

The following message will be displayed on the monitor screen after clicking the yellow warning symbol. You can select the language in which the message is displayed.



Caution

The IOTA LR2 model should not be used without an independent clinical evaluation and is not intended to be a screening test or to determine whether a patient should proceed to surgery. Incorrect use of the IOTA LR2 model carries the risk of unnecessary testing, surgery, and/or delayed diagnosis.

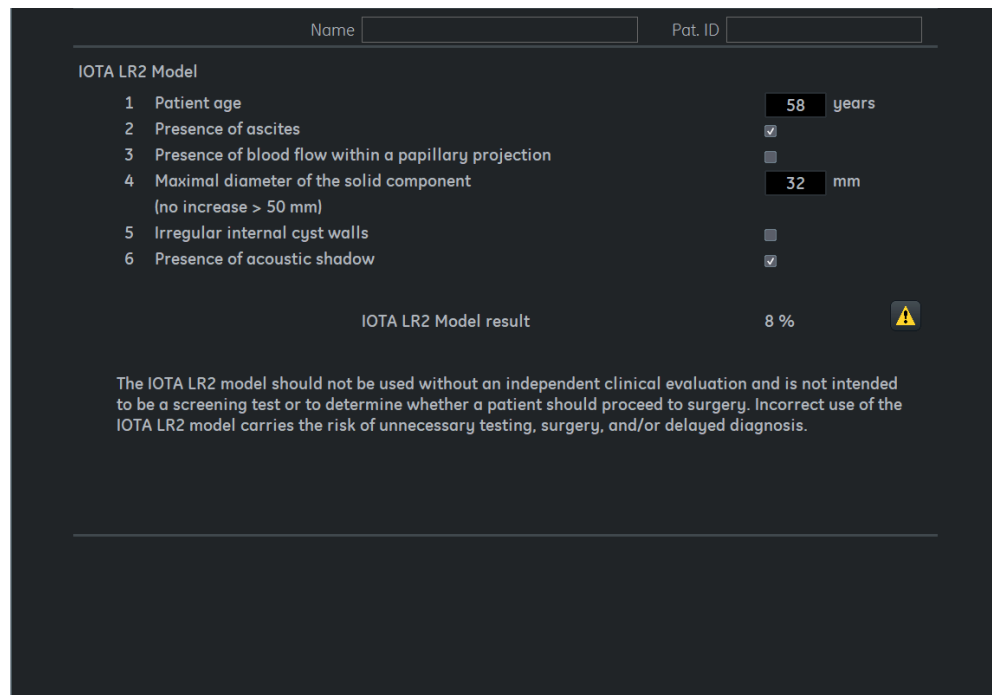

10.5.6 IOTA Simple Rules Worksheet

Note *IOTA Simple Rules is an option. If more than one IOTA option is available (i.e. IOTA LR2, IOTA Simple Rules, IOTA ADNEX), it is possible to configure in the measure setup which worksheet is displayed.*

Note *IOTA Simple Rules may not be available in all countries.*

The IOTA (International Ovarian Tumor Analysis) Simple Rules Worksheet contains an ovary measurement tool for women with adnexal tumors that have been selected to undergo surgery. The IOTA Simple Rules model is based on published literature and has been tested only on the stated population. The literature states that the IOTA Simple Rules model can help to estimate the probability of an adnexal mass of being malignant.

Note *IOTA states that use outside of the intended population can over- or underestimate risk. Users are expected to study the literature and reach their own professional conclusions regarding the clinical utility of the tool. The model cannot replace experience in ultrasonography and cannot compensate for equipment that may be uncalibrated or otherwise in need of service/repair .*



Caution

Users of IOTA Simple Rules should have specific experience on how to use the program and be familiar with the IOTA terminology. Relevant information on the use of IOTA Simple Rules is available at www.iotagroup.org

The IOTA Simple Rules model is stated in literature as described in the Advanced Reference Manual GE HealthCare is passing on this IOTA Simple Rules worksheet for your convenience based on published literature of one group, but makes no representation of its effectiveness in your practice. This calculation is not to be used as the primary driver in diagnostic decision making on the probability of malignancy. It is secondary information for a physician to use based on recent literature.

Workflow

1. Select the IOTA Simple Rules Model on the Gynecology worksheet touch panel.
2. Select the relevant items. If all items get deselected, a message asking to clear the results appears. Press **Yes** to clear the results or **No** to display the corresponding result.
3. The IOTA Simple Rules risk result is displayed. It consists of an exactly calculated result and the corresponding classification.

The IOTA Simple Rules Worksheet contains a preoperative classification system for ovarian tumors consisting of five features typical for benign tumors (B-features) and five features typical for malignant tumors (M-features).

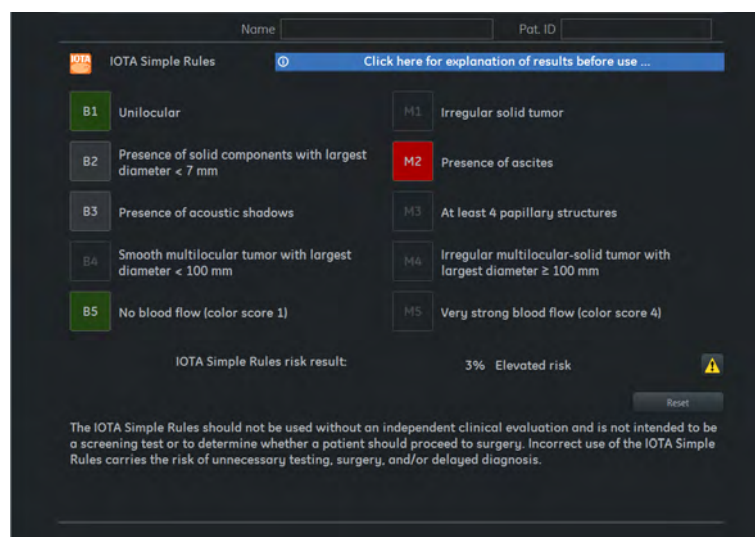

Note A yellow warning symbol is displayed. The following message will be displayed on the monitor screen after clicking the yellow warning symbol. You can select the language in which the message is displayed.



Warning

The IOTA Simple Rules model should not be used without an independent clinical evaluation and is not intended to be a screening test or to determine whether a patient should proceed to surgery. Incorrect use of the IOTA Simple Rules model carries the risk of unnecessary testing, surgery, and/or delayed diagnosis.

The result of the calculation is displayed as the IOTA Simple Rules risk result. By pressing the blue info badge, more detailed information and the table on which the results are based, are displayed:

TABLE 10
Summary classification of Simple Rules risk calculation based on all data (n = 4848)

Features	Observed malignancy rate	Estimated individual risk of malignancy	Classification
No M-features AND >2 B-features	171/75 (0.6%)	<0.01–0.29%	Very low risk
- No M-features AND 2 B-features - No M-features AND feature B1 present	20/1580 (1.3%)	0.19–2.7% 1.2–3.1%	Low risk
No M-features AND 1 B-feature present (except B1)	60/722 (8.3%)	2.4–15.2%	Intermediate risk
- No features - Equal no. of M- and B-features - >0 M-features, but more B- than M-features	451/1096 (41.1%)	27.5–48.7% 5.6–78.1% 1.3–28.4%	Elevated risk
More M- than B- features present	1133/1295 (87.5%)	42.0–99.9%	Very high risk

This simplified system only provides risk ranges for no. of B- and M-features present, but facilitates clinical triaging in absence of electronic devices. Personalized risk estimates can be obtained in second step.
B-feature, benign feature; M-feature, malignant feature.
Timmerman et al. Simple ultrasound rules to predict risk of malignancy in adnexal masses. Am J Obstet Gynecol 2016.

Consult the user manual for additional information.
For more details visit the IOTA group homepage:
www.iotagroup.org

Close

Inconclusive results might occur from conflicting combinations: As soon as one button is pressed, the button which would lead to an inconclusive result is disabled.

- M1 - B1
- M1 - B4
- M3 - B1
- M3 - B4
- M4 - B1
- M4 - B4
- M5 - B5
- B1 - B4
- M1 - M4

If the measurement **Solid CpT** results in less than 7mm, the feature **B2 Solid Component** is automatically selected.

The color of the buttons (green for B-features and red for M-features, gray) indicate their state (selected, deselected, disabled/not selected).

Discard clears all selections except the measurements.

An IOTA assessment touch panel based tool can be started from the Patient ID menu. **Worksheet** and Assessment tool are synchronized and show always the same values. Swipe down on the touch panel to open the Assessment tool menu.

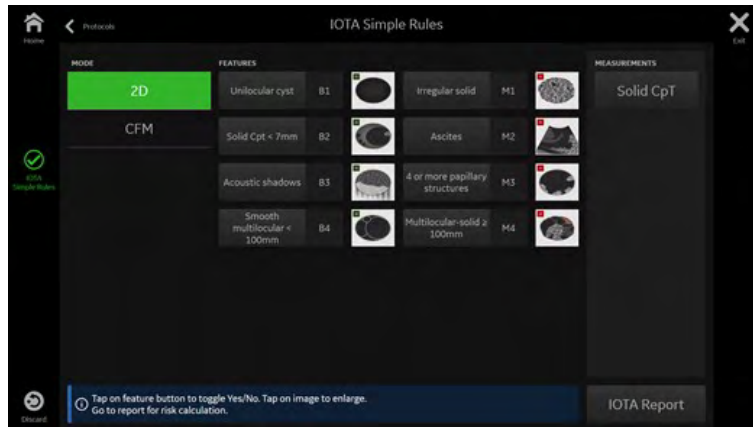

Figure 10-11 Assessment Tool (example)

10.5.7 IOTA ADNEX Worksheet

Note IOTA ADNEX is an option. If more than one IOTA option is available (i.e. IOTA LR2, IOTA Simple Rules, IOTA ADNEX), it is possible to configure in the measure setup which worksheet is displayed.

Note IOTA ADNEX may not be available in all countries.

The IOTA ADNEX risk model can be used by medical doctors to preoperatively assess ovarian cancer in women who have at least one persistent adnexal (ovarian, para-ovarian, and tubal) tumor. The IOTA ADNEX Model estimates the probability that an adnexal tumor is benign, borderline, stage I cancer, stage II-IV cancer, or secondary metastatic cancer (i.e. metastasis of non-adnexal cancer to the ovary).



Caution

Users of IOTA ADNEX should have specific experience on how to use the program and be familiar with the IOTA terminology. Relevant information on the use of IOTA ADNEX is available at www.iotagroup.org

The IOTA ADNEX model is stated in literature as described in the Advanced Reference Manual.

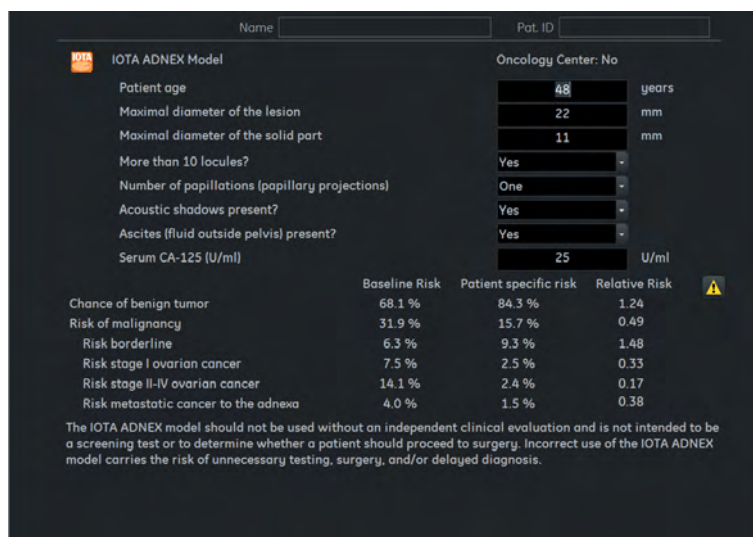

Figure 10-12 The IOTA ADNEX model menu

Note A yellow warning symbol is displayed. The following message will be displayed on the monitor screen after clicking the yellow warning symbol. You can select the language in which the message is displayed.



Warning

The IOTA ADNEX model should not be used without an independent clinical evaluation and is not intended to be a screening test or to determine whether a patient should proceed to surgery. Incorrect use of the IOTA ADNEX model carries the risk of unnecessary testing, surgery, and/or delayed diagnosis.

Workflow

1. Select the IOTA ADNEX model on the Gynecology worksheet touch panel.
2. Fill in all items (i.e. **Patient Age**, **Maximal diameter of the lesion**,...). If a value entered is out of the corresponding range, a message with the valid range is displayed.
3. Press **Calculate** as soon as all items are filled.

Note

*It is possible to calculate the result without filling in the **Serum CA-125** level. A message appears asking whether to continue (**Yes**) or not (**No**).*

4. The IOTA ADNEX result is displayed. It consists of several parts showing the **Baseline Risk**, **Patient specific risk** and **Relative risk** for several values. An additional page with a graphical display of the IOTA ADNEX Model result is available.



Figure 10-13 Baseline Risk



Figure 10-14 Patient risk (only available when a result exists)

An IOTA assessment touch panel based tool can be started from the Patient ID menu. **Worksheet** and Assessment tool are synchronized and show always the same values. Swipe down on the touch panel to open the Assessment tool menu.

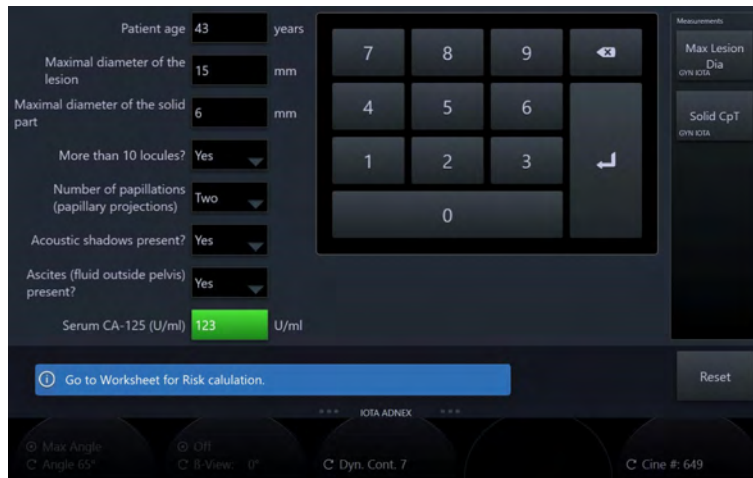
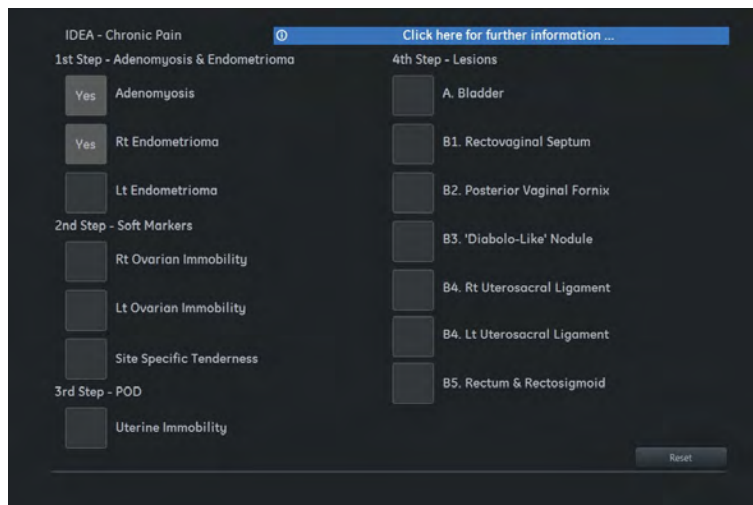

Figure 10-15 Assessment Tool (example)

10.5.8 IDEA Worksheet

The **IDEA Chronic Pain** contains all IDEA findings available in the IDEA assessment tool. Each item can be selected (**Yes / No**) individually by pressing the corresponding button. The selection is the same as in the IDEA assessment tool when the **IDEA Chronic Pain** is opened/closed.



A click onto the blue badge opens the IDEA info dialog displaying additional information. The dialog is closed by pressing **Close**.

Reset resets all selections in the IDEA summary.

The second page of the **IDEA Chronic Pain** displays the IDEA measurements. It is possible to edit or delete (🗑️) the values displayed.

An IDEA assessment touch panel based tool can be started from the Patient ID menu. **Worksheet** and Assessment tool are synchronized and show always the same values. Swipe down on the touch panel to open the Assessment tool menu.

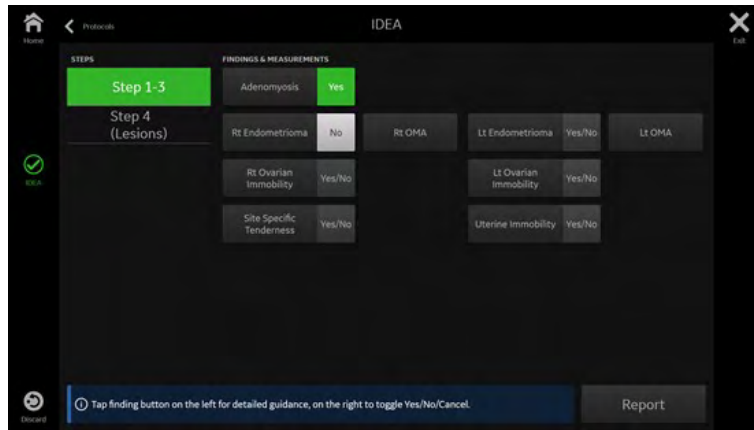

Figure 10-16 Assessment tool (example)

For each step the corresponding **Findings** are displayed. It is possible to select the items individually (**Yes / No**). Press the measurement button to start the measurement. A tap onto the desired findings button opens the corresponding dialog displaying additional information.

Discard resets all selections in the IDEA assessment tool.

Report opens the **Worksheet** with the IDEA page selected automatically.

10.5.9 fetalHS Worksheet

The *fetalHS* worksheet contains the same data as on the summary page of the *fetalHS* Assessment tool. All editable controls are synchronized with the assessment tool. If values are changed in the worksheet, they are changed in the assessment tool automatically and vice versa. The comment box is editable on the *fetalHS* page. The controls to edit the text above the images are part of the Fetal Anatomy section.

10.5.10 Fibroid Mapping Worksheet

Depending on the settings configured in the Measure Setup, the corresponding results are displayed in the Fibroid Mapping worksheet. For Endometrium and Uterus the calculated volumes are displayed. For each fibroid measurement type, position and comments are available if FIGO or General classification is active.

Note Changes can only be made in the Fibroid Mapping tool.

Fibroid Mapping		Vol. [cm ³]				
Endometrium		5.57				
Uterus		142.12				
	D1 [mm]	D2 [mm]	D3 [mm]	Avg. D [mm]	Vol [cm ³]	
Fibroid 1*	29.9	17.5	17.3	20.8	4.723	Comment
Type					Position	
Fibroid 2*	18.6	8.1	8.1	10.6	0.617	Comment
Type	Intramural				Position	Posterior
Fibroid 3*	11.6	9.4	9.1	10.0	0.519	Comment
Type	Intraligamentary				Position	Right, Right Lateral

Figure 10-17 Fibroid Mapping Worksheet (example)

10.5.11 Biophysical Profile / Cardiovascular Profile Score

Biophysical Profile			Cardiovascular Profile Score (CVPI)				
(0 - 2)			(0 - 2)				
Nonstress Test	<input checked="" type="radio"/> 0	<input type="radio"/> 1	<input type="radio"/> 2	Hydraps	<input checked="" type="radio"/> 0	<input type="radio"/> 1	<input type="radio"/> 2
Fetal Movements	<input type="radio"/> 0	<input checked="" type="radio"/> 1	<input type="radio"/> 2	Heart Size	<input type="radio"/> 0	<input checked="" type="radio"/> 1	<input type="radio"/> 2
Fetal Breathing Movements	<input type="radio"/> 0	<input type="radio"/> 1	<input checked="" type="radio"/> 2	Cardiac Function	<input type="radio"/> 0	<input type="radio"/> 1	<input checked="" type="radio"/> 2
Fetal Tone	<input type="radio"/> 0	<input checked="" type="radio"/> 1	<input type="radio"/> 2	Venous Doppler	<input type="radio"/> 0	<input type="radio"/> 1	<input checked="" type="radio"/> 2
Amniotic Fluid Volume	<input checked="" type="radio"/> 0	<input type="radio"/> 1	<input type="radio"/> 2	Arterial Doppler	<input type="radio"/> 0	<input type="radio"/> 1	<input checked="" type="radio"/> 2
Total	4 / 10		Total	7 / 10			

Figure 10-18 Biophysical Profile / Cardiovascular Profile Score (example)

Select the required value (0-2) for the items listed. The Biophysical Profile total score is displayed as soon as one item is selected, to display the Cardiovascular Profile total score all items have to be selected.

10.6 Assessment Tools

The Assessment tools provide the possibility to fill out the worksheet outside from them. One of the advantages is to have the US Image visible while filling out the worksheet with the help of an assessment tool.

Starting/selecting an Assessment Tool can also be done by pressing **Protocols** on the touch panel. Three different states are available:

1. No Scan Assistant or Assessment Tool is started: Select the desired tool or list and press **Start**. The menu closes automatically.
2. Already ongoing Scan Assistant list or Assessment Tool:
 - The ongoing Assessment tool list is paused. Press **Continue** to go on.
 - Select a Scan Assistant list and press **Start**. The menu closes automatically.
 - Press Reset to clear the currently selected list or tool. Confirm the clearing of data (**Yes**) or decline (**No**).
3. No exam started: A message appears together with the **Start Exam** button. Press the button to open the Patient Information Dialog.

It is also possible to open the **Annotation** and **Report** menu when **Protocols** is open. As soon as one of those menus is closed, the previously displayed **Protocols** menu appears again.

10.6.1 fetalHS



Caution

*fetal*HS is intended for use with gestational ages between 18 and 25 weeks only.

In the protocols menu a video is available for the *fetal*HS tool. If a tap is performed on the preview image, the video window appears with the corresponding video.

The *fetal*HS tool consists of several steps. As soon as one step is finished the corresponding value is displayed and the step is marked with a checkmark. The next step is activated automatically. To go back to a previous step, tap onto it.

For each step a discard symbol is available. If pressed a message appears asking whether the selected data should be discarded or not. Click **Yes** to discard the data or **No** to cancel.

Video tutorials are available for the different steps in the video tutorial window. Images/cines saved in the *fetal*HS tool are marked on the clipboard. Following controls are available:

- **Play/Pause** to start and stop the video
- a volume slider to reduce or increase the volume
- a video slider which shows the current progress and the current time of the video. Moving forward/backward to change the progress is possible.
- **Close** to close the video

Magnification should be chosen in a way that the entire thorax of the fetus is visible in a transverse view.

Available steps:

1. Step 1: Fetal Presentation

A blue info box containing an image with hints and a preview image is displayed. Tap onto the image to open the video tutorial. Additionally a pictogram showing how to handle the probe is displayed.

Available buttons:

- **Cephalic Lie**
- **Breech Lie**

- **Transverse position not supported (exit)**

- Note** *If more than 1 fetus was selected in the patient dialog a fetus control is displayed. It is possible to switch between fetuses (the data is cleared when the fetus is switched, already entered data is reloaded).*
- Note** *Only Cephalic and Breech presentations are supported. If **Transverse position not supported (exit)** is pressed, the fetalHS window is closed and changes are discarded.*
2. Step 2: Spine Position
A blue info box containing an image with hints and a preview image is displayed. Tap onto the image to open the video tutorial.
Select the desired spine symbol button (i.e. **Spine at 3 o'clock**, **Spine at 4 o'clock**,...) to define the spine position.
- Note** *The selected spine position influences the pictograms and reference images of the following steps. They are rotated accordingly.*
- Note** *If more than 1 fetus was selected in the patient dialog a fetus control is displayed. It is possible to switch between fetuses (the data is cleared when the fetus is switched, already entered data is reloaded).*
- Note** *Only spine positions between 3 o'clock and 9 o'clock are supported. If the spine position is between 10 o'clock and 2 o'clock, significant bone shadows may occur. Try to reposition the probe to bring the spine to a valid position.*
3. Step 3: Stomach Position
According to the selected value in step 2 a reference image and a pictogram appear. Read the question in the information box and confirm the correct view with **Yes**, otherwise press **No**.
Select **Show Figure/Show Example Image** to display figures or example images.
- Note** *The orientation of the displayed pictograms and reference images is based on the chosen spine position. If the fetus changed position during the procedure, the orientation of the pictograms / reference images may no longer match the orientation observed in the ultrasound image.*
4. Step 4: Abd to 4CH
Run mode is activated with this step. A blue info box with instructions is displayed.
Press **Start Level of AC** and **End Level of 4CH** to store a cine (last 3 seconds before **End Level of 4CH** was pressed) to the clipboard. As soon as saving of the cine is completed, the step is finished.
5. Step 5: 4CH to Neck
Run mode is activated with this step. A blue info box with instructions is displayed.
Press **Start Level of AC** and **End Level of 4CH** to store a cine (last 3 seconds before **End Level of 4CH** was pressed) to the clipboard. As soon as saving of the cine is completed, the step is finished.
6. Step 6: 4CH
The cine which was saved before (step 4) is reloaded. An AI algorithm starts automatically to find the 4CH view. After the algorithm is finished a message whether a 4 Chamber View was found or not appears. If successful, the cine cursor is set to the found image automatically and a green message box appears informing that a 4 Chamber View was found and in which frame it was found. A tap onto this message box displays the chosen frame on the US image. In case of successful view detection it is possible to go through the cine with the trackball to select a different view if needed.
Read the question in the information box and confirm the resemblance of the view with **Yes**, otherwise press **No**. If the resemblance was confirmed, answer the second question concerning the correct view and confirm with **Yes**, otherwise press **No**. If the automatic view detection was not successful, select a different view with the trackball by hand or press **Try again** to reactivate step 4. After the cine is saved the tool activates step 6 again.
Select **Show Figure/Show Example Image** to display figures or example images.

7. Step 7: Cardiac Axis

The image saved in step 6 (4 Chamber View) is reloaded automatically. An AI algorithm starts which measures the cardiac axis. If the AI algorithm is able to perform a measurement, press **Set** or edit the measurement manually if needed. A message informs about the found axis and the measurement result. If the measurement cannot be performed, the manual cardiac axis measurement is activated and a message appears.

It is possible to adjust the measurement by moving the trackball. Press **Change** to switch between the points of the currently selected axis and **Change Axis** to switch between the axes available. Press **Set** to finish the measurement.

The normal range is marked with color. Read the question in the information box and answer with **Yes** or **No**.

Press **Start Measurements** to restart measurements after they were canceled before.

8. Step 8: 3 Vessel Trachea

As soon as this step is started, the cine which was saved before (step 5) is reloaded. An AI algorithm starts and looks for a 3VT view. If a 3 VT view is found, the cine cursor is set to the found image automatically and a green message box appears informing that a 3 VT view was found and in which frame it was found. A tap onto this message box displays the chosen frame on the US image. Read the question in the information box and confirm with **Yes** to confirm the correct view, other wise press **No**.

If no 3VT view is found by the algorithm an important information is displayed. It is possible for the user to look for the 3VT view manually. Select Try again to reactivate step 5. After the cine is saved the tool activates step 8 again.

Select **Show Figure/Show Example Image** to display figures or example images.

9. Step 9: Summary

Displays the following content:

- **Stomach**
- **4-Chamber view**
- **3-vessel trachea view**
- **Cardiac axis**
- **Fetal position**
- **Share for Referral** (only available when eMail is configured in the system setup; summary page, images from the clipboard (.jpg) and cine from the clipboard (mp4) are sent via eMail)
- **Close:** Closes the tool.
- **Comment:** Allows to enter user defined text.
- **Fetus:** fetus control for more fetuses (if available). It is possible to switch between fetuses (entered data is reloaded).
- **Report:** Opens the *feta/HS* page.
- **Start Fetus x:** Switches to the next fetus (B, C, D) and starts the process from the beginning.

Images, dropdown menus and comment text boxes are synchronized with the *feta/HS* worksheet. The content of the dropdown boxes is also synchronized with the Fetal Anatomy worksheet.

10.7 Accuracies

Introduction

The possible accuracy of geometric, flow speed or other measurements with this Ultrasound system is a result of various parameters that shall be equally considered. The used images shall be optimized and scaled to provide the best view of the examined structures. To ensure this, the correct choice of the ultrasound probe and imaging mode for a certain application plays an essential role.

It is also important to be aware of increased inaccuracies caused by the ultrasound beam traveling through inhomogeneous human tissue with layers of various sound speeds.

Therefore differences between operators shall be minimized by standardization of measurement procedures.

Geometric measurements

To obtain good results with distances, areas and volumes the examined structure shall be placed in the center of the image and zoomed as much as possible. Geometric measurements, particularly in 3D data, shall only be done in regions where the structures are clearly resolved. Otherwise the specified accuracy can drop significantly.

Considering a sound speed of 1540 m/s (average for human tissue), following inaccuracies shall be taken into account for distances ≥ 33 mm:

Measurement	Accuracy
Distance	+/- 3%
Area	+/- 6%
Circumference	+/- 3%
Volume	+/- 9%

For distances < 33 mm an absolute inaccuracy ≤ 1 mm can apply.

Note *Area and volume accuracies are derived from the values for distance (only distances > 33 mm are assumed):*

- Inaccuracy for areas : \leq +/- 6% (Distance 1 x Distance 2)
- Inaccuracy for volumes : \leq +/- 9% (Distance 1 x Distance 3)

In modes where additional information is overlaid to the B-mode (e.g. CFM, PD, Elasto), the caliper measurements shall be taken with reference to the B-mode image to meet the stated accuracy.

For 2D array probes the accuracy limitations above are valid for the azimuth direction (Bmode cross-section). For all other cross-sectional views and measurements, following inaccuracies shall be considered for distances > 33 mm:

Measurement	Accuracy
Distance	+/- 7%
Area	+/- 14%
Circumference	+/- 7%
Volume	+/- 17%

The volume inaccuracy of 17% is derived from the sum of the azimuth and elevation values (7% each) and the axial value(3%). For 2D array probes and distances of less than or equal to 33 mm an absolute inaccuracy of less than or equal to 2.3 mm can apply.

Flow speed measurements

Operating mode	Max. rel. deviation
CW	≤ +/- 6%
PW	≤ +/- 8%

These values can be obtained in the full range provided that a good adjustment of the ultrasound image according to the Basic user Manual has been done, including a proper angle correction. Furthermore it shall be considered that these uncertainties are valid for a sound speed of 1540m/s (average of soft tissue) . In heterogeneous tissue, particularly with high fat content, an additional error of about 5% can occur and shall be taken into account (for more explicit values respective literature should be studied.)

Other Measurements

Following accuracies apply for other measured values

Measurement	Accuracy
Time	+/- 3%
Heart rate	+/- 3%
Strain ratio	+/- 32%

Chapter 11

System Setup

11.1 System Setup

Modifications of the system parameters are done in the system setup menu. All main system setup menus and the depending sub menus (tabs) are selectable on the touchscreen. A switch between the main system setup menus is also possible with monitor side menu.

Save & Exit

Save: This button saves all changes without leaving the system setup.

Save & Exit: This button saves all changes and after saving the system setup menu will be closed.

Pressing **Exit** just means leaving the system setup menu without saving any changes. By pressing **Return** the current dialog or sub menu is left and the previous menu appears.

There are three possible ways to exit the system settings menu:

- **Exit** button on the screen.
- **Exit** button on the touchscreen.
- **Exit** key on the User Interface.

All exit buttons are synchronous in their appearance. Either all of them are enabled or disabled at the same time.

11.1.1 Settings

Settings includes:

- General
- Details
- Annotation
- Clipboard
- Patient/ Archive

11.1.1.1 General

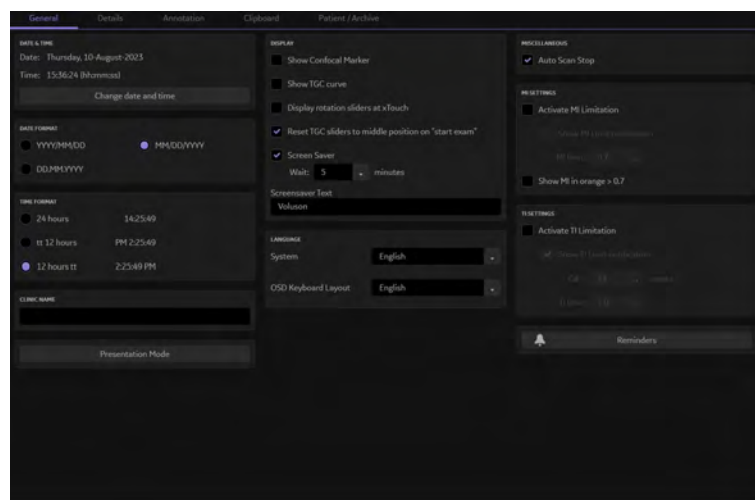

Figure 11-1 General

Controls

Change Date & Time	<p>Date/time adjustment: A sub dialog appears in which date, time and time zone can be adjusted. OK saves the changes and closes the window.</p> <p>NTP Time Server Settings: A checkbox is available to choose Synchronize with NTP time server. There are entry fields for the NTP server as well as for update intervals. The Update now button synchronizes with the NTP server.</p>
Date Format	Select the desired date format.
Time Format	Select the desired time format.
Clinic Name	Select the text box to enter a new clinic name. The clinic name will be copied into the Hospital ID in the information header after closing with Save & Exit .
Language	System: Select the desired language and press Save & Exit . The system reboots by itself, which is necessary to change the current language. Only languages available on the system are listed. If a new language is installed, it is automatically added to the list.
Display	<p>Select which of the following items should be displayed:</p> <ul style="list-style-type: none"> ● Show Confocal Marker: If checked, a manual adjustment of the focus with the focus controls (depth and numbers) is available for confocal probes. ● Show TGC curve ● Display rotation sliders at xTouch ● Reset TGC sliders to middle position on "start exam" ● Screen Saver: <ul style="list-style-type: none"> <input type="radio"/> If Screen saver is checked, a screen saver appears after a definable time of inactivity (in Freeze mode only). <input type="radio"/> Screensaver Text: Select the text box to enter a screen saver text. The text is saved after closing with Save & Exit. The default entry is overwritten.
Miscellaneous	<p>On/off selection for:</p> <ul style="list-style-type: none"> ● Auto Scan Stop: Freeze mode is activated automatically after 5 min of inactivity. <p>Note <i>After 60min of inactivity the system automatically activates freeze mode independent from whether Auto Scan Stop is enabled or not. 30sec before Auto Scan Stop is activated, a message appears for 5sec. In each 4D mode, Auto Scan Stop is activated automatically after 5 min, even if Auto Scan Stop is selected as OFF.</i></p>
MI Settings	<p>Select the desired settings:</p> <ul style="list-style-type: none"> ● Activate MI Limitation: Select whether to Activate MI Limitation. When MI Limitation is active and the entered limit is exceeded, the MI is displayed in orange. As soon as Start Exam is pressed or the user preset changed, the limit exceeding MI values are set back to the values defined in the system setup. <p>Note <i>The MI limitation is not active in Shear Elasto mode.</i></p> <ul style="list-style-type: none"> ● Show MI Limit notification: Select whether to have a notification displayed or not. ● Show MI in orange > 1.0: The MI at the Info Header is colored in orange if the MI is greater than 1.0. At reload no colored MI is displayed. If MI limit 1.0 is set to another value, the value shall be displayed and valid for the coloring.

TI Settings

Select the desired settings:

- **Activate TI Limitation:** Select whether to **Activate TI Limitation** and define the desired **GA** and **TI limit**. When **TI Limitation** is active and the entered limit is exceeded, a message appears. Tib Tic and Tis are displayed in orange. As soon as **Start Exam** is pressed or the user preset changed, the limit exceeding TI values are set back to the values defined in the system setup.

Note *The AO may change when the TI limit is changed.*

- **Show TI Limit notification**

TI limit notification 1st Trim: Select the desired TI limit. As soon as the limit is reached the value is displayed in orange and a message appears. When **Start Exam** is pressed or the user preset changed, a TI value higher than the selected limit is reduced to the selected value again.

Note *The orange color for exceeding values is only displayed for Tib, Tic and Tis when the GA is entered and smaller than 14w 0d.*

Note *If a TI value which is visualized on the console display exceeds the selected value, it is reset to the selected value when either an exam is started or the user preset is changed.*

Note *The TI limitation is not active in Shear Elasto mode.*

Note *The **TI Limitation** applies only to TI parameters displayed on the ultrasound screen.*

Presentation Mode

Runs the presentation mode of the US-device.

Note ***Exit**, **Freeze** and trackball keys are activated for presentation mode, after click **start** button.*

- *Pauses: Press **Freeze** key*
- *Restart: Press **Freeze** key in the pause state.*
- *Exit: Press **Exit** key.*
- *Move to the next image: Press the right trackball key*
- *Move to the previous image: Press the left trackball key*

Reminders

Opens the **Reminders** dialog where it is possible to configure customized messages (i.e. reminder to delete the archive, to remove probes,...) displayed on the monitor and touch panel of the system. As soon as a reminder is displayed, select the desired option:

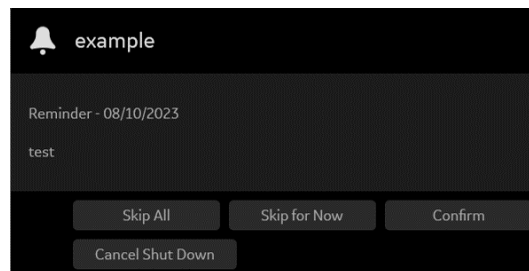

- **Confirm**: the reminder is confirmed and closed
- **Skip for Now**: the reminder is closed for the moment but can be reopened
- **Skip All**: all reminders are closed for the moment but can be reopened
- **Cancel Shutdown**: closes the reminder dialog, no shutdown is executed

Setup:

A press onto the button displays a list of available reminders.

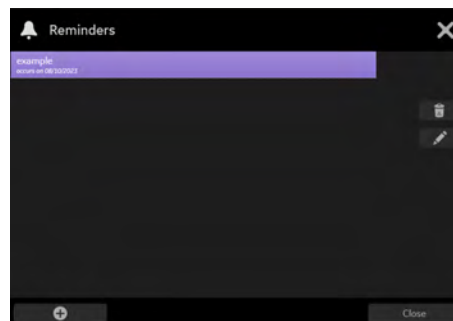

- To add a new reminder, select . Enter the desired reminder title and text, a start date, when to display the reminder (**at start-up** or **before shutdown**) and **Repeats**.

Note *If no date is configured, the reminder is not displayed automatically, only when opened up by pressing the reminder icon on the status bar.*

- To add a new reminder, select . Enter the desired reminder title and text, a start date, when to display the reminder (**at start-up** or **before shutdown**) and **Repeats**.

- To delete a reminder, select . Select **Save** to save the changes or **Cancel** to close the dialog without saving any changes.

Presentation Mode

There are two ways to start Presentation Mode :

- Press start button in the **System Setup - Settings - General - Presentation Mode**
- Press **Start Presentation Mode** from shortcut menu in the left column of the menu screen.

Presentation Mode supports JPEG, PNG and MP4 files.

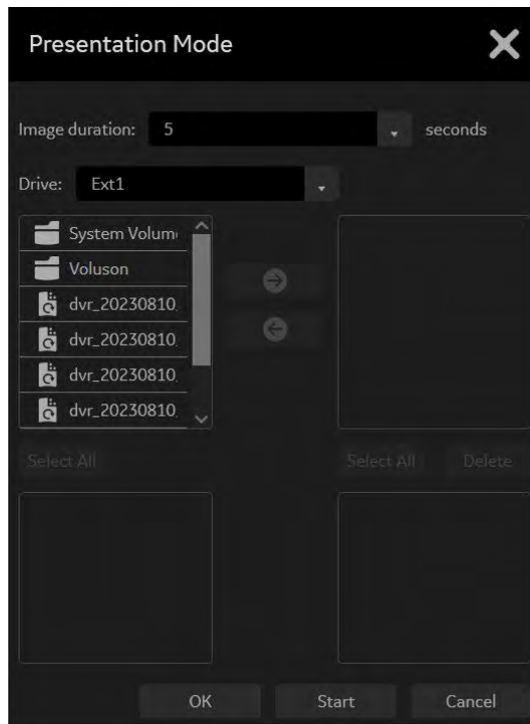

Figure 11-2 Presentation Mode

Image Duration	Defines the time how long an image is displayed in Presentation Mode. (Range: 1-20 sec)
Drive	Choose an external medium (USB).
--> & <--	Copy pictures from the external register to the internal register and vice versa.
Select All	All pictures or videos in the associated register are marked.
Delete	The marked pictures or videos are cleared. A dialog appears.
OK	Closes the dialog and remembers changes of image duration. Changes are only activated if Save & Exit is pressed in the system setup dialog.
Start	Starts Presentation Mode with the configured image duration.
Cancel	Closes the dialog and discards changes.
Preview window	If a picture/video is marked in the internal or external register it is shown in the associate preview window. If more than one picture is marked, no preview is available.

11.1.1.2 Details

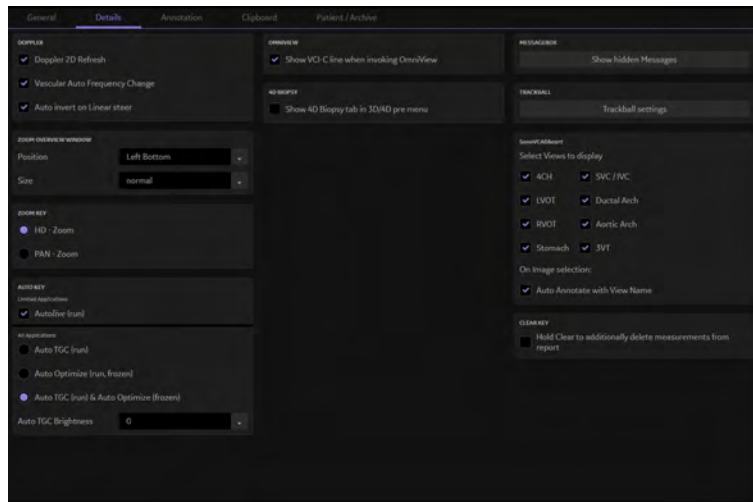

Figure 11-3 Details (example)

Controls

Doppler

- **Doppler 2D Refresh:** If checked (default), in PW Mode the 2D scan is updated each time the gate is moved. Otherwise the 2D scan is never updated in PW mode.
- **Vascular Auto Frequency change:** If checked (default), the system uses at the vascular applications an algorithm for changing the frequency and the depending PRF.
- **Auto invert on Linear steer:** If checked (default), the PW spectrum is inverted automatically when the steer angle changes from plus to minus and vice versa. The **Invert** button on the screen changes accordingly.

Zoom Overview Window

Define Position and Size of the Zoom Overview Window or turn it off completely.

Zoom Key

While in Zoom Pre Mode, select which Zoom Mode (Pan Zoom or HD Zoom) is activated automatically, if the Zoom hardkey is pressed again.

Auto Key

Configure the **Auto Key** button.

Auto/live(run): Automatic gain optimization on images in real time.

Select between:

1. Auto TGC (run): only the TGC sliders and the B-gain value are optimized (default)
2. OTO (run, frozen): the gamma curve is optimized to increase contrast
3. Auto TGC (run) & OTO (frozen): both functions

Define a brightness delta value (Auto TGC Brightness) for the automatic optimization of TGC and B-gain. This delta value is added to the fixed brightness value set of each application setting.

OmniView

"Show VCI-C Line when invoking OmniView" can be checked. When this box is checked, a default horizontal straight line (VCI-C line) is included, otherwise not.

4D Biopsy

Select whether to display the **4D Biopsy** tab in 3D/4D pre menu.

Messagebox

Show hidden messages: All hidden messages are shown again.

Trackball

Trackball speed: The trackball speed of listed functions can be changed and saved.

SonoVCAD™heart

Configure the settings for SonoVCAD™:

- **Select Views to display:** Check which views should be displayed.
- **On Image selection:** If checked the name of the view is automatically inserted within the upper left corner of the full size image.

Clear Key

Check **Hold Clear Key to additionally delete measurements from report** to automatically delete all annotations, bodymarks, indicators, measurements and the whole content of the worksheet with a long press on the hardkey **Clear**.

11.1.1.3 Annotation

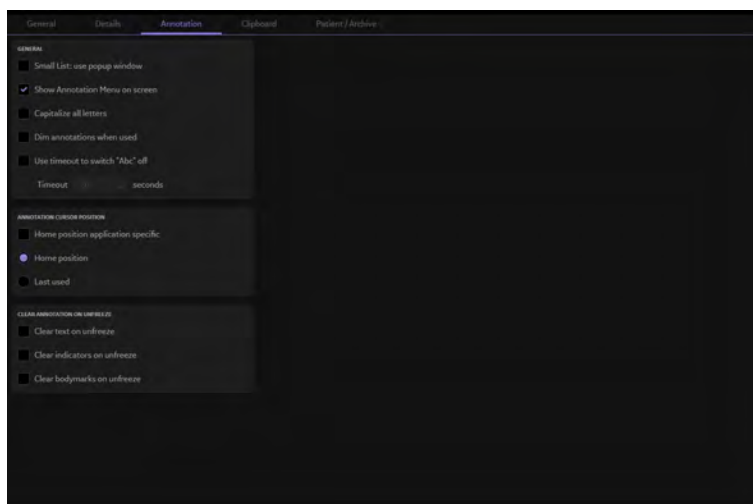

Figure 11-4 Annotation

Controls

General

Define which items to use/display:

- **Show Annotation menu on screen:** Shows the Annotation Menu on the screen display.
- **Capitalize all letters:** When this check box is activated all the letters will be capitalized automatically.
- **Dim annotations when used:** If checked, the annotations change their color / appear dimmed as soon as they are used. When a new exam is started, the color changes back to normal appearance.
- **Use timeout to switch "Abc" off:** Defines the timeout for annotation mode. After timeout system switches back to scan mode.

Annotation Cursor position

Defines the cursor position when annotation button **Abc** is pressed.

- **Home position application specific:** Cursor home position stored for each package when in image annotation mode.
- **Home position:** Cursor home position.
- **Last used:** Last used cursor position.

Clear Annotations on unfreeze

Define which annotations (text, indicators, bodymarks) should be cleared automatically when the system state is changed from freeze to unfreeze. Select between:

- **Clear text on unfreeze:** The text of the active layer is cleared automatically.
- **Clear indicators on unfreeze:** All indicators of the image area are cleared automatically.
- **Clear bodymarks on unfreeze:** All bodymarks of the image area are cleared automatically.

11.1.1.4 Clipboard

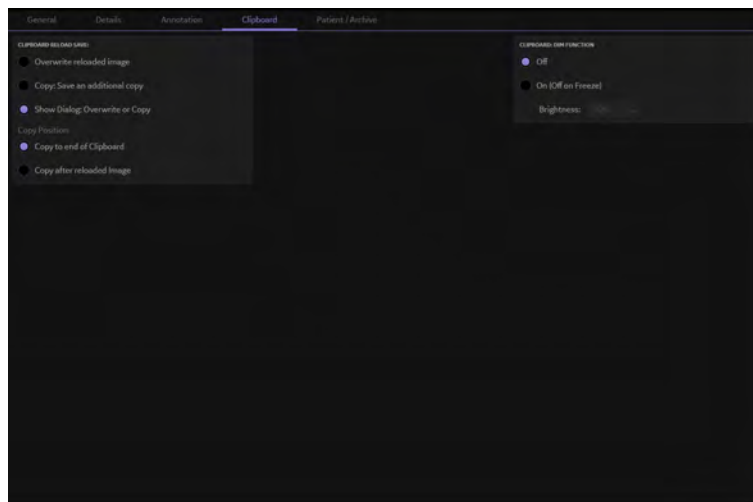

Figure 11-5 Clipboard

Clipboard Reload Save Choose an option for positioning a reloaded image after saving.

Clipboard Dim Function Choose dimming on/off of the Clipboard while in scanning. The brightness of the Dim Function can be adjusted.

Table 11-1 Controls

11.1.1.5 Patient/Archive

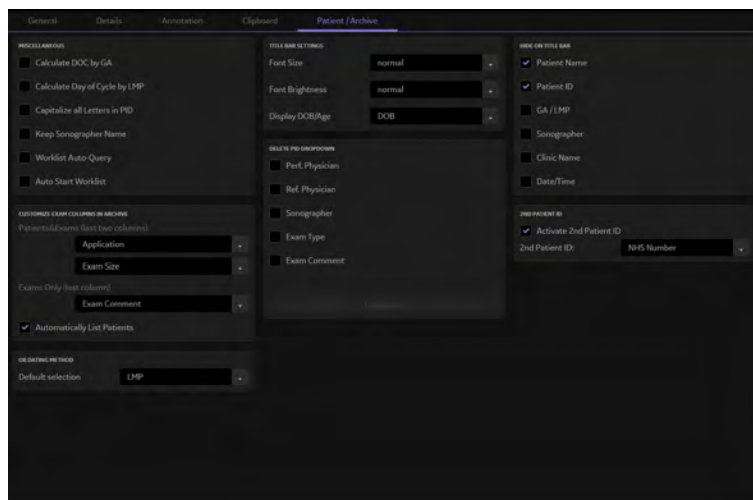

Figure 11-6 Patient / Archive

Controls

Miscellaneous	<p>Select whether to:</p> <ul style="list-style-type: none"> ● Calculate DOC by GA: automatically calculate the DOC (Date of Conception) when a GA was entered in the current patient dialog. ● Calculate Day of Cycle by LMP: automatically calculate the Day of Cycle when a LMP was entered in the current patient dialog. ● Capitalize all Letters in PID: capitalize all letters in the Patient Info Display or not. ● Keep Sonographer Name: the last entered sonographer is still displayed after an exam is ended. ● Worklist Auto-Query: the worklist is automatically queried with the entered Patient ID or Patient Name and today's date when the Worklist button is pressed in the Current Patient Screen. If this box is not checked, the worklist is only queried after the Search button is pressed in the Worklist dialog. If no connection to a Worklist server is available the former queried Worklist data (Show locally stored data) is shown. ● Auto Start Worklist: the worklist dialog is shown automatically after the PID Button is pushed.
Customize Exam columns in Archive	<p>Define the information displayed in Patients & Exams (last two columns) and Exams Only (last Column). If Automatically list patients is checked, all available patients are displayed when the Current Patient Search or the Archive dialog is opened.</p>
OB dating method	<p>Select the desired dating method.</p>
OB/GYN Gender	<p>Select the desired gender for OB and GYN exams:</p> <ul style="list-style-type: none"> ● -- ● female ● male
Title Bar Settings	<p>Define Font Size (small, normal, large), Font Brightness (bright, normal, dimmed) and Display DOB / Age.</p>
2nd Patient ID	<p>Check Activate 2nd Patient ID if desired. If checked, the 2nd Patient ID is displayed at Report, Structured Report, Worksheet, PID and on all exports and prints.</p>
Delete PID Dropdown	<p>Delete List deletes all entries in the selected dropdown lists. Available checkboxes:</p> <ul style="list-style-type: none"> ● Referring Physician ● Performing Physician ● Sonographer ● Exam Type ● Exam Comment
Hide on Title Bar	<p>Select which information should be hidden in the title bar. Available checkboxes:</p> <ul style="list-style-type: none"> ● Patient Name ● Patient ID ● GA/ LMP ● Sonographer ● Clinic Name ● Date/Time

11.1.2 Protocols

11.1.2.1 Scan Assistant

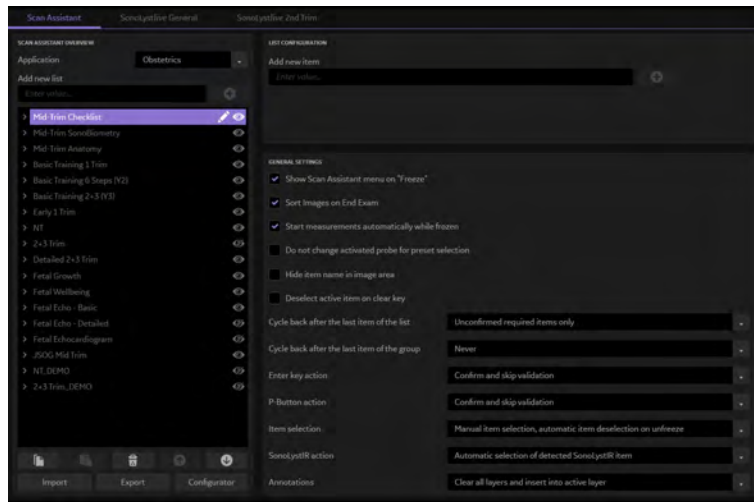







Figure 11-7 Scan Assistant (example)

Controls

Application	Select the desired application.
Add new list	Add a new Scan Assistant list (max. 36 characters allowed for the list name).
Add new group	Add a new Scan Assistant group to the currently selected list (max. 36 characters allowed for the group name).
Add new item	Add a new Scan Assistant item to the currently selected list (max. 36 characters allowed for the item name).
	Copies the selected list, group or item entry (only one by one).
	Pastes the copied list, group or item. A dialog appears asking for a name (max.36 characters) for the copied entry. Enter a name and click OK or Cancel to close the dialog without pasting.
	Makes the selected list visible (listed at the PID / touch panel menu) or invisible (not listed at the PID / touch panel menu).
	Deletes the selected list/group/item.
	Move the selected entry (items, lists, groups) up or down. (Only available when an item is selected.)
Show Scan Assistant touch menu on Freeze	If selected/checked the Scan Assistant touch menu opens on Freeze .
Sort Images on End Exam	If selected/checked images are sorted according to the Scan Assistant list.
Start measurements automatically while frozen	If selected the measurement of an active item starts automatically after pressing Freeze . Changing to another item with included measurement in frozen mode will start also the included measurement automatically. If not selected, the measurement has to be started manually.
Do not change activated probe for preset selection	If checked the current active probe/preset remains selected independent of the item configuration.
Hide item name in image area	If checked, the currently selected item name is not displayed in the image area.
Deselect active item on hard key clear	if checked, a hard key Clear deselects the currently active scan assistant item.

- Cycle back after the last item of the list**
- Select the desired action:
- **Unconfirmed required and optional items:** When the last Scan Assistant item of the actual list is finished, the first unchecked item (required or optional) in this list is activated automatically.
 - **Unconfirmed required items only** (default): When the last Scan Assistant item of the actual list is finished, the first unchecked required item (not valid for optional items) in this list is activated automatically.
 - **Never:** no action after the last item of the list.

- Cycle back after the last item of the group**
- Select the desired action:
- **Unconfirmed required and optional items:** When the last Scan Assistant item of the actual group is finished, the first unchecked item (required or optional) in this group is activated automatically.
 - **Unconfirmed required items only:** When the last Scan Assistant item of the actual group is finished, the first unchecked required item (not valid for optional items) in this group is activated automatically.
 - **Never:** no action after the last item of the list.

- Enter key action**
- Select the desired Enter key action:
- **None:** no function
 - **Confirm and skip value:** the item can always be checked, even if a required step is missing (same as a manual check at the touch panel).
 - **Confirm with validation:** the item can only be checked when all required steps are complete (i.e. measurement completed, image saved,...).

- P-button action**
- Select the desired P-button action:
- **Confirm and skip value:** the item can always be checked, even if a required step is missing (same as a manual check at the touch panel).
 - **Confirm with validation:** the item can only be checked when all required steps are complete (i.e. measurement completed, image saved,...).

- Item Selection**
- Select between:
- **Manual item selection and deselection:** switch to the next item after selecting an item on the touch menu manually.
 - **Manual item selection, automatic item deselection on confirmation:** when an item is confirmed with a Px button, Enter key, or on the touch menu, the active item is deselected.
 - **Manual item selection, automatic item deselection on unfreeze (default):** on unfreeze the active item is deselected.
 - **Automatic selection of next item on confirmation:** switch to the next item after confirming with a P-button, Enter key or checking on the touch menu.
 - **Automatic selection of next item on unfreeze:** switch to the next item with unfreeze.

- SonoLystIR action**
- Select between:
- **Select item:** If an item is found by the SonoLyst algorithm it is selected automatically.
 - **Automatic selection of detected SonoLyst item and open touch panel Scan Assistant menu:** If an item is found by the SonoLyst algorithm it is selected automatically and the Scan Assistant menu appears.
 - **Suggest item on Scan Assistant menu:** If an item is found by the SonoLyst algorithm it is marked visually (not selected).

Annotations

Select the desired function:

- **Clear all layers and insert into active:** Clears layer 1 and 2 and adds the annotations to the active layer.
- **Clear layer 1 and insert into layer 1:** Clears layer 1 and inserts annotations into layer 1.
- **Clear layer 2 and insert into layer 2:** Clears layer 2 and inserts annotations into layer 2.
- **Insert into active layer when confirming with P-button:** If an ultrasound image/cine is saved, printed or sent to a DICOM destination and the Scan Assistant Item is confirmed by pressing a Px button, the annotation, which is defined for the active item is inserted automatically in the active layer of the saved/printed/sent image.
- **Clear all and insert into active layer on Freeze:** All annotations are cleared and a configured **Annotation** is added into the active layer after pressing **Freeze**.

Note *On unfreeze all annotations are cleared.*

Configurator

Opens the **Configurator** dialog to export a Scan Assistant Configurator.

1. Select the desired settings:
 - **Save in:** lists all connected extensions, network drives,.... where the export can be saved.
 - **File name:** enter the desired file name.
2. Press **Save** to close the dialog and to start the export process or **Cancel** to close the dialog without export. A status message after the export informs about its success/failure.
3. After a successful export start the Scan Assistant Configurator on your PC (required OS: Windows® 10 64 bit).
4. Double click at the ScanAssistantConfigurator.exe to start the installation process. Check that you agree to the license terms and conditions and press **Install**. If you want to change the installation path, press **Options**. **Close** closes the dialog without installation. During installation a progress bar is visible. After successful installation a success message appears.

Note *A second start of the Scan Assistant Configurator changes the dialog. A **Repair** button (to repair the current installation / for reinstallation) and an **Uninstall** button (to uninstall the complete installation) appear.*

The setup of the Scan Assistant with the help of the Scan Assistant Configurator is equal to the Scan Assistant setup on the device. As soon as the Scan Assistant Configurator is started, a window appears.

1. Select **File** (the configuration file can be exported from the US device) to open the **Load Configuration** dialog with the last 5 configuration files (if available).
2. Select the desired file and press **OK** or **Browse** to open a Windows® dialog for selecting a configuration file. **Cancel** closes the dialog without loading a configuration.
3. **Save Configuration** opens a save as dialog to save the current file (Use this configuration file to import it onto the US device.).
4. **Select language** lists all available languages to choose from.
5. **Recent backups** lists the last 10 loaded configuration files.
6. **Exit** closes the Scan Assistant Configurator. Decide whether you want to save unsaved changes or not.

Note *It is not possible to load a configuration file when the dependencies do not match (i.e. Scanner series). Select **About** at the menu bar to show the details.*

Export

Exports the Scan Assistant settings.

1. Press **Export** to open the Export dialog window.
2. Select the desired location to export the Scan Assistant settings to.
3. It is possible to enter a file name. The filename will be extended with the serialnumber, date and time.
4. Press **Save** to start the export process or **Cancel** to close the dialog without exporting data.
5. A message appears telling whether the export failed or is completed.

Import

Imports the saved Scan Assistant settings.

1. Press **Import** to open the Import dialog window.
2. Select the location to import the configuration from (i.e. internal HDD, network, external USB devices) and press **Load**. A new dialog appears. Choose the desired file to be imported. Press **OK** to start the import or **Cancel** to close the dialog.
3. After the file is loaded, a dialog appears. Select the desired option:
 - **Import all lists and replace existing:** Deletes the complete current list and replaces it with the imported one.
 - **Import selected lists and append to existing:** Enables the list for manual selection. When **Select all** is checked, all lists are appended to the existing configuration. If a lists with the same name exists already, the imported list's name is extended with a sequential number in brackets.
 - **Replace general settings:** The existing settings are overwritten with the settings of the imported file.
4. Press **Import** to start the importing process or **Cancel** to close the dialog without importing the selected file.

Item Configuration

Select an item from the Scan Assistant list to configure its settings.

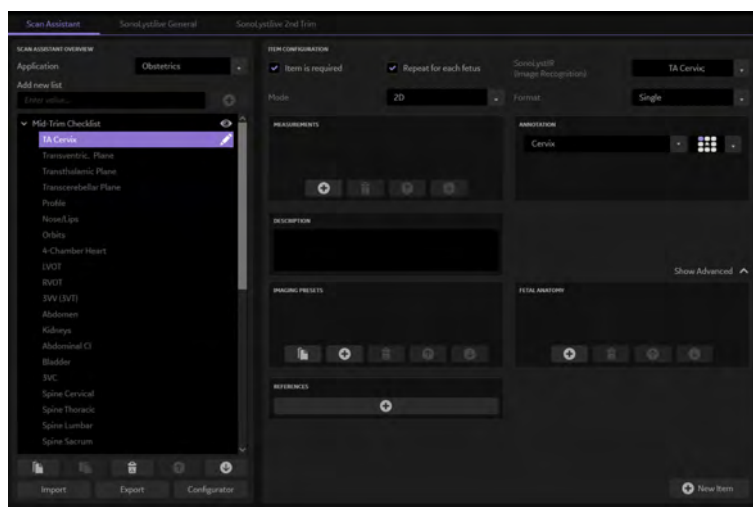

Figure 11-8 Scan Assistant Item Configuration (example)

Show Advanced

Press **Show Advanced** to activate advanced mode and display the corresponding controls. If advanced mode is not activated, only a summary of the current configuration (if available) is displayed.

SonoLyst

Link SonoLyst (plane detection) to a Scan Assistant item. Multiple selections are possible. **Disable** clears the current selection.

Mode

Select the desired mode for each Scan Assistant item.

Item is required

If checked the item is defined as required.

Repeat for each fetus

If checked the item is performed for each fetus.

Format / Automation

Depending on the selected mode, three display formats are available (last used, single, dual, quad). In 3D mode it is possible to select the desired **Automation** if the corresponding options are set (None, SonoAVC™*follicle*, SonoAVC™ *antral*, SonoCNS).

Annotation

It is possible to enter annotations for each item by typing directly into a text field (supported by an auto-fill function). A dropdown menu displays application dependent annotations.





: Select the desired annotation position:

- top-left
- middle-left
- bottom-left
- top-right
- middle-right
- bottom-right
- bottom-center
- top-center
- home position (default)

Note *It is possible to select individual annotation positions for dual and quad format. Format icons are displayed then (not for single format).*

Imaging Presets

It is possible to configure more than one imaging preset for an item. The configured probe/preset is displayed in this box. Placing the mouse pointer into the box displays a tooltip with the current configuration.

1. Press  or  (only available if no preset is selected) to open the configuration menu.
2. Select the desired probe (option and mode dependent) and 2D or 3D/4D preset. An already configured probe / preset is marked with a blue dot.
3. **Application Filter:**
 - selected: Based on the selection of the Scan Assistant List Application only the corresponding probes and presets are displayed.
 - not selected: All probes and presets are displayed independent of the selected Scan Assistant List Application.
4. Press **OK** to save all changes and close the dialog or **Cancel** to leave without any changes.

It is also possible to copy, add / edit, delete or move probe / preset configurations up and down. Presets displayed on top of the list have highest priority.

Description

Enter the desired description into the text box.

References

It is possible to add max. 3 reference images to an item. Press  to open the reference dialog:

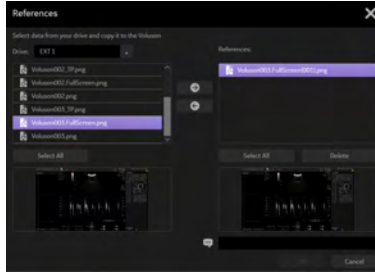

1. Select the desired Drive (an external medium).
2. Navigate through the displayed folders. Only *.bmp, *.jpg and *.png are selectable.
3. Press **Select all** to mark all references and/or use the arrows to copy the desired references from the source to the internal register and vice versa.
4. Enter a comment if desired and press **OK** to close the dialog and save the changes or **Cancel** to close the dialog without saving the changes.

Measurement

Press  to add a measurement. A dialog appears. Select the desired measurements and click **Add** or **Cancel** to close the dialog without any changes. Depending on the measurement **Laterality** can also be entered.

Define whether a measurement is **required** or **optional**. If a measurement is set to **optional** it is labeled accordingly.

Fetal Anatomy (OB)

All selected Fetal Anatomy items (max. 5) are displayed. Press  to add a Fetal Anatomy item. A dialog appears. Select the desired fetal anatomy item and click **OK** or **Cancel** to close the dialog without any changes. Depending on the measurement **Default** can also be entered (only available at OB).

It is also possible to filter for SonoLyst items (only available when the option is set). Then only the SonoLyst related items are displayed and labeled with a SonoLyst badge. If the depending plane is detected a default values is displayed, too.

Findings (GYN)

All selected Finding items (max. 5) are displayed. Press  to add a Finding item. A dialog appears. Select the desired finding (only available when **Gynecology** is selected) and click **OK** or **Cancel** to close the dialog without any changes.

New Item

Press **New Item** to create a new item.

11.1.2.2 SonoLystlive General

Note

SonoLyst is an option. The tab is only displayed when the option is set.

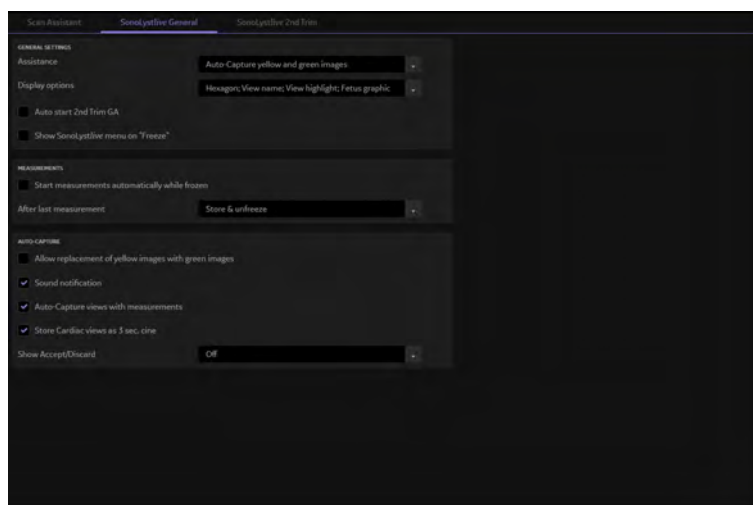

Figure 11-9 SonoLystlive General (example)

General Settings

- **Assistance:** select between:
 - Background:** when a captured image is saved via P-button, the capture count is updated and the view name of the captured view is displayed in the status message
 - Manual:** Auto-Capture is not active; the capture count is updated when an image is accepted
 - Auto-capture yellow and green images:** good view (green) and medium view (yellow) images are saved automatically
 - Auto-capture green images:** good view (green) images are saved automatically
- **Display options:** select between:
 - Off**
 - Trackball status Hexagon** (auto-capture symbol below the B-image)
 - Trackball status View name** (view name below the B-image)
 - Progress View Pictogram Highlight** (highlight of the affected views graphic)
 - Progress Fetus graphic** (displays/hides the fetus graphic)
- **Auto start 2nd Trim GA:** When the GA for the active exam is $\geq 18w0d$, SonoLystlive starts automatically
- **Show SonoLystlive menu on Freeze:** If selected the **SonoLystlive** menu is opened automatically when **Freeze** is pressed.

Measurements

Start measurements automatically while frozen: If selected and a measurement is configured for the current detected view, the measurement is started automatically after **Freeze** is pressed.

After last measurement: select between:

- **Do nothing:** the view has to be stored manually
- **Store:** if selected and after the last configured measurement is finished, this view is stored to the clipboard.
- **Store & unfreeze:** if selected and after the last configured measurement is finished, this view is stored to the clipboard and the system state changes from **Freeze** to write mode.

Auto-Capture (only available when **Auto-capture yellow and green images** or **Auto-capture green images** is selected for assistance)

- **Allow replacement of yellow images with green images:** When checked: partially compliant (yellow) images can be replaced by subsequent fully compliant (green) images of the same view. The new captured view replaces the same existing view.
When unchecked: fully compliant (green) images captured after partially compliant (yellow) images of the same view will be appended. They are additionally added to clipboard and do not replace an existing view.
- **Sound notification:** If selected a sound notification is played when a view is stored to the clipboard.
- **Auto capture views with measurements:** enabled auto capture function for views with measurements
- **Store cardiac views as 3sec. cine:** If selected following views are auto-captured as 3sec. cine:
 - 4-Chamber Heart
 - LVOT
 - RVOT
 - 3V/3VT
- **Show Accept/Discard:** It is possible to **Accept/Discard** the last captured view with the help of trackball or the touch keys and to close the window. If another view is auto-captured in the meantime, the previous view is replaced.
Select between:
 - Off:** No window/menu appears, the detected view is added to the clipboard without confirmation.
 - Main screen:** If selected a window on the monitor appears after view detection and displays the last auto-captured view.
 - Touch panel:** If selected a touch menu appears after view detection and displays the last auto-captured view.

- **Screen & touch:** If selected a monitor window and a touch menu appear after auto capturing and display the last auto-captured view.

11.1.2.3 SonoLystlive 2nd Trim

Note *SonoLyst is an option. The tab is only displayed when the option is set.*

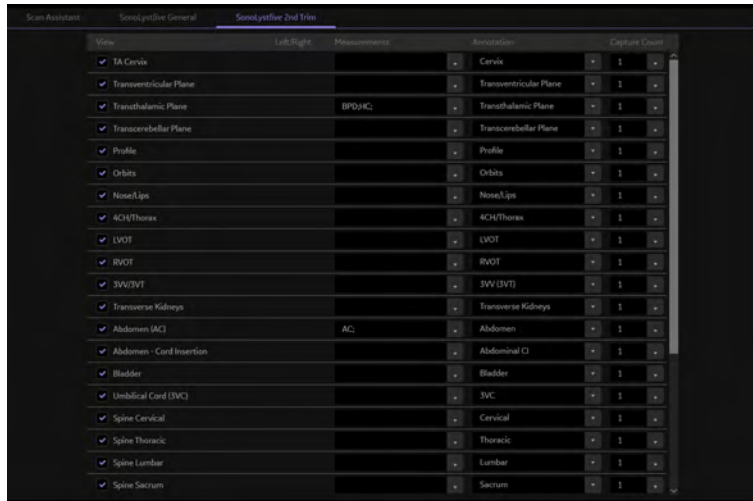

Figure 11-10 SonoLystlive 2nd Trim (example)

It is possible to add one or more individual measurements to each selected (green checkmark) view. Click onto the **Measurement** field to open a dialog where measurements can be added, edited (incl. Preset, Subcategory, Study,...) or deleted for selected views as desired.

Furthermore it is possible to choose between **Left/Right/Both. Manual indication of left/right hands/feet/extremities** means that if selected, no auto-capture is executed until **Left/Right/Both** is defined via trackball. If enabled and a corresponding view is detected, a message appears. As soon as **Left, Right** or **Both** is pressed, the image is accepted and the **Accept/Discard** window/touch menu is closed. The depending icon in the miscellaneous area increases the capture count. **Discard** deletes the image from the clipboard and closes the **Accept/Discard** window/touch menu. If enabled, all configured extremities are displayed doubled in the miscellaneous area.

It is also possible to add an annotation to each view. Either select an **Auto Text** from the dropdown menu or enter annotations freely. The configured annotation is added to the captured view and stored.

Set up a store capture count for each view (1-5). The capture count is increased by auto-capture and manual storing. If the set number is reached, the algorithm ignores the view in the ongoing exam for detection.

11.1.3 Administration

Administration includes:

- System Info
- Options
- Service

11.1.3.1 System Info

This tab gives information about the Software and Hardware System.

11.1.3.2 Options

This page shows all available system options and their states.

P	Permanent	Option is permanently activated (purchased).
I	Inactive	Option is not activated.
D	Demo	Option is activated for demo and expires on the date shown in the “Valid” column.

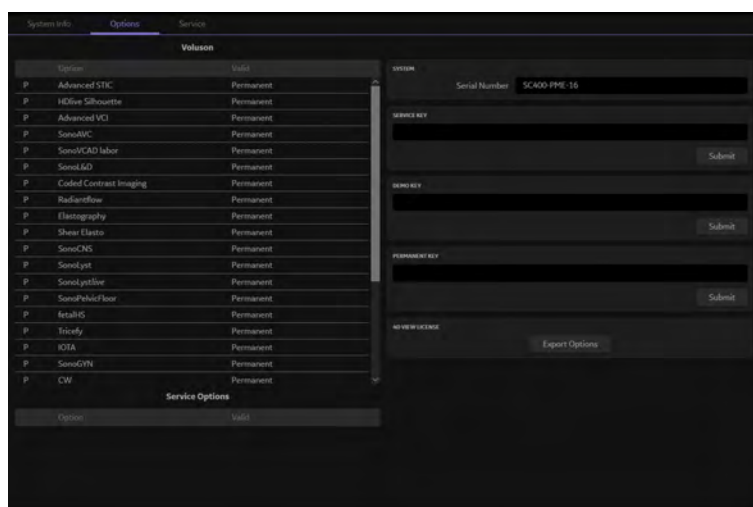

Figure 11-11 Option (example)

- System** Shows the serial number of the System.
- Service Key** This field is used to enter the service key.
- Demo Key** This field is used to enter and show the demo key (all options are available for a certain period of time) from OKOS.
- Permanent Key** This field is used to enter and show encoding key for permanent available options.
- 4D View License** Press **Export Options** to open a dialog window for selecting a 4DView license file:
- The **Look in** dropdown menu lists all connected USB drives.
 - The browsing area displays all folders and .lic files.
 - **Open** opens the selected .lic file. When the .lic file is invalid, a message appears. Press **OK** to close the message. When the .lic file is valid, the file on the USB device is replaced by the new file with the same name and the options from the device. The system displays a message whether the export was successful or not. **OK** closes the message.
 - **Cancel** cancels the process and closes the dialog window.

Installing a Demo- or Permanent Key

1. Position the cursor inside the input field desired and press **Set**.
2. If one exists, clear/edit the current key code.
3. Enter the encrypted serial code with the keyboard and then click on **Submit** (The code will be checked.)
4. Click the **Save & Exit** button.

- Remark**
- **After activating a key code, restart the system.**
 - **To Exit the System Setup without saving, click the Exit button.**

11.1.3.3 Service

1. Position the cursor into the displayed “password window” and press **Set**.

2. Press the desired button. Select Service Tools to display the Service Tools window (Update, Disk Encryption, Education Videos, Tools, Democases,...) or the button ASI for opening the "Additional Software Installation" dialog. SWI from Media provides system updates from an external device (DVD or USB-Device). Voluson Update opens the Voluson update dialog. **SWI from Media** provides system updates from an external device (USB-Device). **Voluson Update** opens the Voluson update dialog.

AAOR Settings found within the Service Tools window : Press this button open the **AAOR Settings** menu. Select the desired button to automatically enter 2D mode and to set the maximum value for the selected button. This mode is not intended to be used for clinical imaging. The purpose is a regulative requiremnt to activate or measure acoustic output settings which maximizes parameter **MI, TIB, TIC or TIS** in different modes.

Note *The availability of this menu depends on the currently used probe. Each button automatically changes the transmit settings of the console in a way that the selected parameter (e.g. **MI**) is maximized. If one of the buttons is selected, the console restarts after exiting the menu. For further information refer to the current Advanced Acoustic Out Reference (AAOR) manual.*

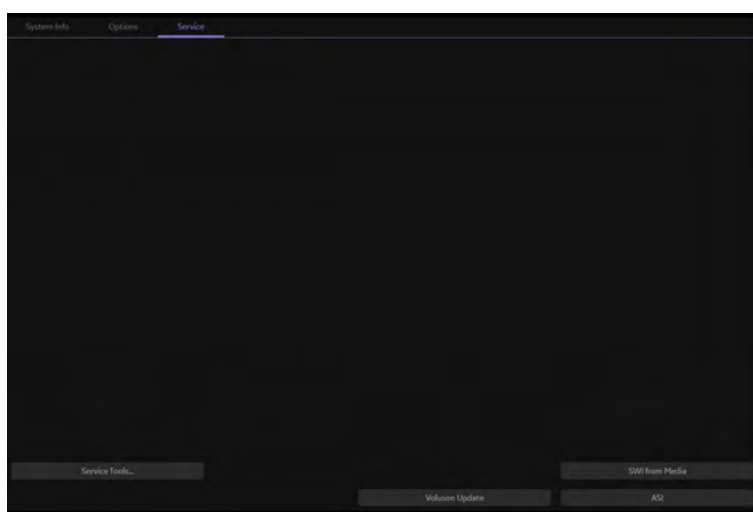

Figure 11-12 Service

Voluson Update

Voluson Update opens the Voluson update dialog. All available updates are listed in the available updates list. If no update is available, the message "No new updates available." appears. Also select **Install after Download** to automatically start the installation after the download is completed or **Shut down system after installation** to automatically shut down the system after the installation is completed if desired. When **Whitelisting** and Disc Encryption are activated, a password can be required due to the settings defined for those options before the solidify process starts.

1. Press **Download**. The download starts. Its progress is shown in the status area. Press **Cancel** to abort the current download.
2. After a successful download, the downloaded files are listed. A message reporting the successful download appears.
3. Press **Start Update** to initiate the installation process. Press **Cancel** to stop. A dialog appears asking whether to really cancel the process (**Yes**) or to continue (**No**).
4. After successful installation the update is added to the history. If the installation of the update was not successful, a message appears. After pressing **OK** the failed update can be downloaded again.

Note *A blue info badge telling the user not to turn off or unplug the system during the update process is displayed.*

Note *The system automatically searches for updates if the corresponding option is set.*

History opens the update history page. **Updates** shows the updates page. **Cancel** closes the dialog. When Settings is pressed, the Proxy Settings dialog appears. Check the box to enable the editing of the Proxy Server Port, User name,... if desired. If checked, the settings are used to connect to the update server. Press **OK** to save the settings or **Cancel** to leave without saving changes.

Note For further details and explanations refer to the Service Manual of the system.

11.1.4 Connectivity

Connectivity includes:

- Peripherals
- Device Setup
- Button Configuration
- Drives
- Device Mgmt (optional)

11.1.4.1 Peripherals

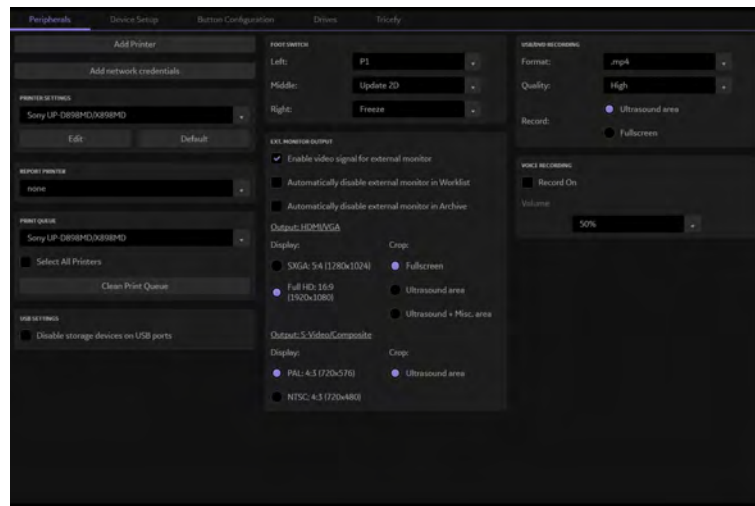

Figure 11-13 Peripherals

Controls

Add Printer	A message box appears. If confirmed with Yes , a new printer can be installed.
Add network credentials	To connect with a Network printer, Network credentials (e.g. Server name,...) have to be added.
Printer Settings	The drop-down list displays all printers available (no DICOM printers).
Edit	Opens the printer setting dialog.
Default	Resets the selected printer settings to the default settings.
Report Printer	Select which printer to use for printing reports from the drop down list.
Print Queue	Select a printer from the pull down menu and press Clean Print Queue to delete all jobs from the print queue of the selected printer. Check Select All Printers and press Clean Print Queue to delete all jobs from all printers installed on the system. Check Select All Printers to automatically select the printers available.

USB Settings

When **Disable storage devices on USB ports** is checked, the system does not recognize when a USB storage device is connected. Therefore the export / import from and the recording to USB storage devices is not possible. A blue info badge is visible in the tab **Drives** when USB ports are disabled.

Note **USB Settings** is part of the *Advanced Security* option.

Foot Switch

Select the functionality of the **Left / Middle / Right** Foot Switch. Choose between **Update 2D, Freeze, P1, P2, P3, P4** and **Vol. Start**.

Depending on the Foot Switch, the **Middle** Option may not be available.

Ext. Monitor Output

Connection of an additional external monitor. Following checkmarks can be set:

- Enable video signal for external monitor
- Automatically disable external monitor in Worklist
- Automatically disable external monitor in Archive

Choose between following outputs:

- HDMI/VGA (Display in SXGA or Full HD): signal output on the rear panel according to the used monitor type. It is possible to select between Fullscreen, Ultrasound area and Ultrasound + Misc. area (e.g. measurement results,...).
- S-Video : (Display in PAL or NTSC) Only the ultrasound area can be displayed.

USB recording

Select the desired recording format (.mp4 or .mpg), the desired recording quality (High, Midle, Low) and the recording area (Fullscreen or Ultrasound area. Ultrasound area is set as default)

Note **USB recording** is an option.

Voice Recording

Enable/disable the microphone. If enabled a default recording microphone volume can be selected.

11.1.4.2 Device Setup

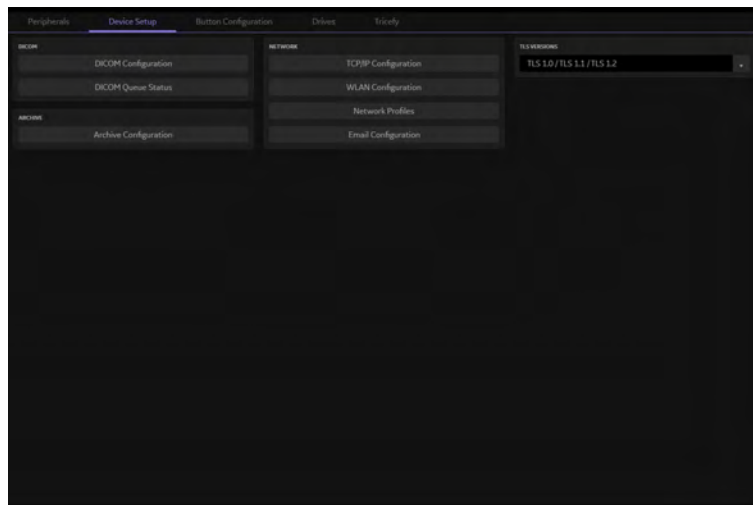

Figure 11-14 Device Setup

It is possible to configure:

- DICOM
- Archive
- Network
- TLS Versions

11.1.4.2.1 DICOM

DICOM is the abbreviation of Digital Imaging and Communications in Medicine. This is the industrial standard for communication of images and other information between medical devices on the network. Using the DICOM option, you can send or print images after connecting your ultrasound equipment and PACS.

This dialog section is used to set up details of all of your DICOM target nodes (image servers). Once you have set up a DICOM node properly, data can simply be transmitted by selecting the appropriate target node.

DICOM Configuration

Name	Site	AE Title	# Address	Port	Color/Class
STORE	DICOM_EXPORT	DICOM_EXPORT	0.0.0.0	0	Color / Original
WORKLIST	WLSTMO	WLSTMO	3-249.69.202	105	
STORE	MODICOM	MODICOM	3-249.69.202	104	Color / Original
STORE	a	a	1	1	Color / Original

Figure 11-15 DICOM Configuration

Controls

discarded

AE Title

Enter the AE (Application Entity) Title under which your DICOM application is known to other DICOM applications (required). For setting the correct **AE Title** please contact your DICOM network administrator.

Station Name

Enter the name of the hospital or institute.

Retry Count

Number of retries to establish a successful DICOM connection.

Retry Count Seq.

Retry count for sequential mode (only valid if **Send sequ.** is checked). If the end number of **Retry Count Seq.** is reached and sending was not successful then the “problem” data set is marked as “failed” in the spooler and the system continues sending the next image data

Retry Interval

Retry interval minutes.

Timeout (s)

Define a timeout interval.

Default

Default values of **Retry Count**, **Retry Count Seq.**, **Retry Interval**, **Timeout (s)** are set.

Test Connection

If a destination from the Destination List is selected and the **Test Connection** button is pressed, the connection to the selected destination is tested. If no destination is selected the button is disabled.

Ping: Ping the selected destination and check the response. The result can be **OK** or **Failed**

Verify: Send DICOM commands and check the response. The result can be **OK** or **Failed**

If a serial report destination is selected, the **Test Connection** button changes to **Send Test Report** and the Ping and Verify fields disappear. A test report is sent to the serial port instead of testing the network connection.

Sound Notification

Acoustic signal for a successful or unsuccessful transfer (sending Images, Structured Report Transfer and Report).

Destination list	<p>Contains all available destinations and displays their Services, Alias, AE Title, IP Address, Port and Color / Size. The checkboxes next to the services mark the currently activated service. Following service types have a checkbox by default:</p> <ul style="list-style-type: none"> ● Worklist ● MPPS ● STR. Report ● Query Retrieve <p>To check the same services is not possible for:</p> <ul style="list-style-type: none"> ● Print ● MPPS ● STR. Report ● Query Retrieve <p>If more than one STORE, or STORAGE COMMIT service is activated, images are sent to all selected destinations and committed with the corresponding STORAGE COMMIT destinations.</p> <p>It is possible to select more than one Worklist service (only if MPPS is not activated). If more than one Worklist service is selected and the MPPS service is added, all selected Worklist services become deselected. A message appears.</p>
TLS	<p>Transport Layer Security (TLS) is a cryptographic protocol designed to provide communications security over a computer network. Settings and activation (green check icon) can be configured with the TLS button in:</p> <ul style="list-style-type: none"> ● Store ● Print ● MPPS ● Storage Commit ● STR. Report ● Query Retrieve ● Worklist ● Report <p>By pressing TLS a window appears which allows to adjust the settings (Use TLS encrypted connection, Use Certificate, Verify Server, Import Certificates, Delete Certificates) as desired.</p> <p>Import Certificates:</p> <ol style="list-style-type: none"> 1. A window appears. Select a drive and a file and press Open. Enter the password if the certificate is protected by a password. 2. Press either OK to save your changes or Cancel to close the dialog without saving any changes. <p>Note <i>If the certificate is not trusted by a certification authority a Windows® Security message can appear. Decide whether to install (Yes) the certificate or not (No).</i></p> <p>Delete Certificates:</p> <ol style="list-style-type: none"> 1. Select the certificate to delete. A window appears. 2. Press Yes to finally delete the certificate or No to keep it.
Add	<p>Pressing the Add button opens the Device Setup dialog, where it is possible to add DICOM destinations. <i>For more information see 'Adding a Service' on page 11-25.</i></p>
Edit	<p>Selecting a destination from the Destination List and pressing the Edit button opens the Device Setup dialog, with the information on the selected destination.</p> <p>The Edit button is disabled if no destination is selected.</p>
Delete	<p>Selecting a destination from the Destination List and pressing Delete removes the selected destination. The Delete button is disabled if no destination is selected</p>

Save&Exit	If the Save&Exit button is pressed, the DICOM Configuration dialog is closed and all changes are saved.
Exit	If the Exit button is pressed, the DICOM Configuration dialog is closed and all changes are discarded.
Note	<i>In Edit mode it is not possible to change the selected Service.</i>

Adding a Service

Select a Service and enter the destination settings (**Alias**, **AE Title**, **IP Address** and **Port**).

Services	<ul style="list-style-type: none"> ● STORE: Send screen images, 2D cine sequences and 3D/4D data to a DICOM server (e.g., Viewpoint). ● STORE3D: Send 3D/4D data only (volumes and cine sequences) to a different store server (e.g., PC with Software 4DView installed) than screen images and 2D cine sequences. ● PRINT: Send images stored in printer clipboard to a DICOM printer. ● MPPS: Send images to a DICOM server with transfer information. ● ST.COMMIT: Send image with an additional layer of security. ● STR.REPORT: Send a structured report. ● QUERY RETRIEVE: Query images or other DICOM objects and Retrieve them from a PACS or other DICOM Modality. ● WORKLIST: Retrieve Patient Information (Name, ID, Birth,...) from an external Worklist server (e.g., HIS - Hospital Information System / RIS, Viewpoint). ● REPORT: Send the Patient report data to a PC via network or serial port.
Alias	Enter a name for the DICOM node to make it easier to handle various nodes. Use any name, but do not insert space characters.
AE Title	Enter the AE (Application Entity) Title under which your DICOM application is known to other DICOM applications (required). For setting the correct AE Title please contact your DICOM network administrator.
IP Address	Enter the host name or IP Address of the DICOM node.
Port	Enter the port number of the DICOM node.

STORE / STORE3D

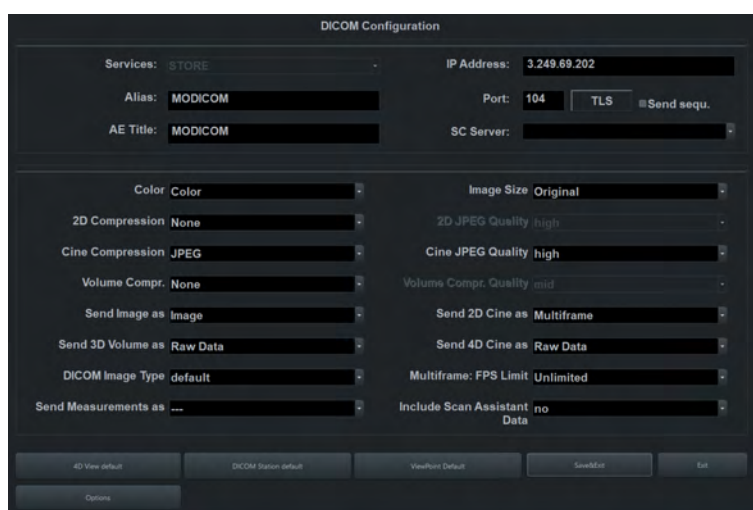

Figure 11-16 STORE / STORE3D View

Edit the Store - Settings as needed.

Send sequ.

- If **Send sequ.** is checked and
 - the **Scan Assistant** is activated :
 - The sequentially “send order” of the images (first, second ...) is derived from the check item order as configured in the setup page (first item, second item ...).
 - If more than one image is available on a check item the send order is defined by the store - date (first stored, second stored ...).
 - If more than one checklist is available: order as configured in the setup page
 - If more than one checklist group is available: order as configured in the setup page
 - Images stored without check item: send order: date, after the checklist items
 - the **Scan Assistant** is deactivated it causes all data to be sent to this server sequentially. This means that only one transfer is active to this server at a time. If one transfer fails, all subsequent transfers are stopped until the failed transfer succeeds or is removed from the queue. (Use for servers that cannot handle multiple associations, or do not sort the images by Image Number.)
- If **Send sequ.** is not checked, up to 5 data sets can be transferred at the same time. This means that transfer is faster. Images can arrive out of order in this case. (Use for servers that have none of the limitations listed in the above paragraph).

Storage Commit

The **Storage Commit** drop down list contains all currently added **Storage Commit** servers. The selected **Storage Commit** server is used for committing the images sent to this store server.

4D View default

Loads the default settings for 4D View. Other destination information must be entered manually.

DICOM Station default

Loads the default settings for DICOM Station. The destination information must be entered manually.

Viewpoint default

Loads the default settings for Viewpoint.

Note

2D JPEG Quality is only active when **2D Compression** is set to **JPEG**.

Cine JPEG Quality is only active when **Cine Compression** is set to **JPEG**.

Volume Compr. Quality is only active when **Volume Compr.** is set to **lossy**.

If the volume contains color information, the color part of the volume is compressed with a setting that is 5 points better than the selected setting, e.g. Setting Mid: color compression High, grey compression Mid

If an image / multiframe cine is compressed using **lossy** JPEG compression, a yellow sign (Jxx; xx = compression factor, e.g. JH) is added to the image (but not to secondary capture images).

If a volume is compressed using **lossy**, a yellow sign (Wxx; xx = compression factor, e.g. W9) is added when reloading the image.



Caution

A lossy compression can reduce image quality which can lead to a false diagnosis!

PRINT

Edit the **Printer Setup** as needed.

MPPS (Modality Performed Procedure Step)

Select the **Store Server** and the **SR Server**.

Only the images sent to the selected **Store Server** are added to the image list of the MPPS completed (or discontinued) message.

Note

As soon as an MPPS server is created and selected, MPPS messages are created when an exam is started or ended.

ST.COMMIT (Storage Commit)

Add a **ST.COMMIT** - Server. These servers can then be selected in the drop down list of the **STORE-**, **STORE3D-** and **STR.REPORT** - Service.

STR.REPORT (Structured Report)

Storage Commit	The Storage Commit drop down list contains all currently added Storage Commit servers. The selected Storage Commit server is used for committing the images sent to this store server.
Combine OB & GYN	If the checkbox is enabled, the system sends the OB- and GYN - data into one file. If not enabled the files will be sent individually.
Include Scan Assistant Data	Select yes or no (default) from the drop down menu.
Include Private Measure Data	Select yes (Retrieve trending data and the transfer of measure data in a private format is enabled) or no (default) from the drop down menu.
	Note <i>DICOM Retrieval of measure data from past exams includes originally transferred data only. Any changes made after transfer cannot be retrieved.</i>
QR Server	Select a available Query Retrieve server from the drop down menu to retrieve measure data at a private format (necessary to retrieve trending data).
Private CSD Identifier	Select the CodingSchemeDesignator scheme for the transfer of DICOM SR data. Available possibilities: <ul style="list-style-type: none"> ● 99GEK ● GEK ● Mixed (used for old private tags (GEK) and newly entered private tags (99GEK))
Viewpoint default	Loads the default settings for Viewpoint.

QUERY RETRIEVE

Select the **Default Appl.** from the drop down menu.

The drop down menu contains exam applications available in patient dialog (Abdomen, OB, GYN, Cardio, Uro, Vascular, Neuro, Small Parts, Pediatric, Ortho). The selected exam application is used for all exams that are imported into the local archive from a remote query/retrieve server.

WORKLIST

Private Tags	Determines whether the private tags defined for communication with the Viewpoint - worklist are used when querying the worklist.
Modality	Select either All or ULTRASOUND . No selection is also possible and defaults to "all".
Add local data	<ul style="list-style-type: none"> ● yes: Locally stored patient data and patient data from the worklist are merged. (Fields that are available in the worklist are taken from the worklist, fields that are only available in the data base are taken from the local data base.) ● no: Data only contained in the worklist is used to populate the patient data fields. No locally stored data is used. ● ask: A dialog is shown whenever there is data from the worklist and from the local database available. Depending on the selection in the dialog, either the action described under yes or no is executed.
Viewpoint default	Loads the default settings for Viewpoint.
Note	Private Tags only work if the other system also supports Private Tags .

REPORT

Select one of the following **Transfer** Modes.

- **Network:** Send the patient report to a PC report station via DICOM network.
- **Serial:** Send the patient report to a PC report station that is connected by serial port. The optional “PRY USB-RS232 Connection kit” must be connected to the system.
When this Transfer Mode is selected, different fields are available: **COM Port**, **Flow control** and **Bits per second**.

Note *The bit rate (**Bits per second**) must be the same as on the receiving PC report station.*

Transfer Sound

There are acoustic outputs for successful or failed transfers. The sounds are played when Images, Structured Reports, Transfers and Reports are sent.

DICOM Queue Status

The Queue Status window displays all DICOM transfers which have not been sent, are being sent at the moment or failed. (Successful transfers are deleted from the list). Status **Conv** is displayed while the data is converted in the format that shall be sent later on (e.g. Converting Raw Data to DICOM Multiframe).

Note *If more than 600 entries exist, a message appears asking to clear the DICOM Queue. If the number of 1500 entries is exceeded, the DICOM transfer is stopped completely due to overflow. Again a message appears informing that no more transfer is possible and that the DICOM Queue has to be cleared.*

Note *If the transfer was successful, but a storage commitment request was not yet successful, the images receive the status **sent**. As soon as the storage commitment was successful the entries (both images and storage commit) are deleted from the list.*

Controls

Hold Queue	The system no longer tries to send data in the queue. As soon as Process Queue is pressed, the system continues to send data.
Retry	Retry the selected exams.
Delete	Delete the selected exams.
Retry all	Retry all exams.
Delete all	Delete all exams, including items that are currently in wait status.
Close	Closes the Queue Status window.
Show information	This button is enabled if a failed DICOM transfer is selected in the Queue list. With this function more information about the failed DICOM transfer can be requested. A window pops up. If the Image is stored in the archive the additional button Go to Archive is available. It opens the archive in Review Mode and the failed image is shown.
Restart Transfer	It is possible to restart the transfer service by pressing Restart Transfer . When the service is not started, the button is highlighted with two gray bars.

11.1.4.2.2 Network

TCP/IP Configuration

Edit the TCP/IP Settings as needed.

Network Adapter Configuration

Before entering the **Network Adapter Configuration** dialog appears asking whether to continue (confirm with **Yes**) or not (confirm with **No**).

Note *It is not recommended to change configurations without being familiar with this task.*

Edit the Network Adapter Settings as needed.

Network Profiles

Define and switch between different network settings for all your work environments to further improve Voluson™ Signature 18 / Voluson™ Signature 20 system's portability.

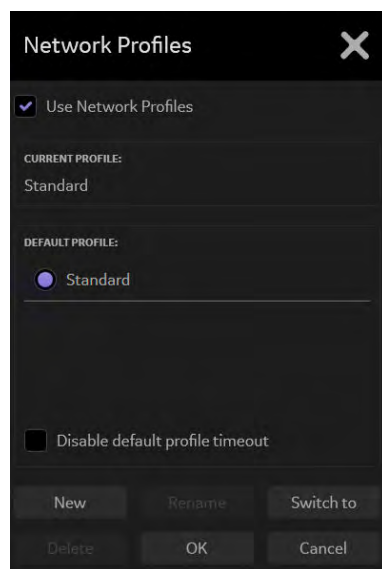

Figure 11-17 Network Profiles

Standard is the default configuration.

Use Network Profiles	During the Boot-Process a window appears to select a Profile. If the Use Network Profiles checkbox isn't activated the system assumes the Standard - profile after the Boot-Process.
Current Profile	Shows the current profile.
Default Profile	Shows all existing profiles. If a Default Profile is checked, the Network Profile window appears during the Boot-Process for 10 sec in which the user can select another Profile. After the 10 sec. the system automatically uses the Default Profile .
Disable default profile timeout	Disables/enables the automatic selection of the default profile after a 10 sec timeout.
New	Add a new Network Profile. A window opens in which a new Profile name can be added. If Current Settings is activated, all current settings are stored under a user definable name. The following settings are stored: <ul style="list-style-type: none"> • All DICOM settings and configurations • Storing the static IP address, gateway, network mask, DNS • Network Printers (without settings) • Report Printer (without settings) • Px Button configuration • Start/End Exam settings • Hospital name • Network-Drive mapping • System's AE title If the lower ComboBox is activated, the user can select another available profile. This Profile with all its settings is copied and stored under a user definable name.
Rename	Rename a selected Profile.

Switch to	Switch between the different profiles.
Delete	Delete a selected profile.
OK	Confirm your selection.
Cancel	Cancel the process of selecting another network profile.

WLAN Configuration

Info *The WLAN adjustments and hardware may differ in some countries. Please check the requirements or talk to your local Online Center.*

1. Open the WLAN Configuration in the System Setup or click on the WLAN icon in the status bar.
2. Select the desired network
3. Insert the network key.

Note *In case you need further assistance, please contact a GE ULTRASOUND KOREA, LTD. service technician.*

Press WLAN Configuration to open the configuration dialog:

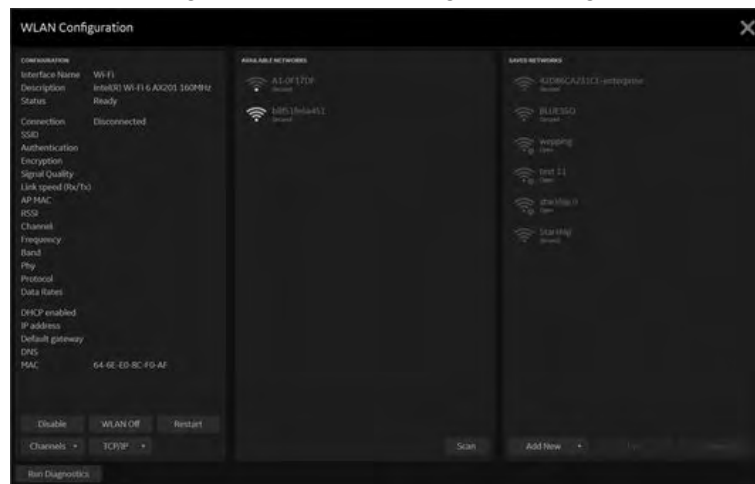

Connect / Disconnect	Connect/Disconnect a selected network.
Scan	Starts the search for all reachable WLAN networks. The list is updated after the search is finished.
Forget	Remove the network from the saved networks list.
Edit	Opens the dialog to edit the network settings.
Add New	Opens a popup window for entering a new network name (SSID).
Up / Down	Move the selected network entry up/down in the saved networks list.
Disable / Enable	Turn the wireless network adapter on/off.
Radio Off / On	Turn the wireless radio on/off.
Channels	Opens a list of all available channels.
TCP/IP	Opens the TCP/IP setting popup window.
Run Diagnostics	Generates a wireless network report. The report is stored in D:\Export
Show details	Opens/closes the additional network information.

Note *If more than one WLAN adapter is available, a tab for selecting the desired one is available.*

Following security controls/settings are available/supported:

1. Security type
 - No authentication (Open)
 - WPA2-Personal
 - WPA-Personal
 - WPA2-Enterprise
 - WPA-Enterprise
 - 802.1X
2. Encryption type

Encryption types for WPA-Personal:

 - TKIP
 - AES

Encryption types for WPA2-Personal:

 - AES

Encryption types for “Shared” and “802.1x”:

 - WEP

Encryption types for “No authentication”

 - WEP
 - None
3. Network authentication method (only possible for WPA-Enterprise, WPA2-Enterprise and 802.1x)
 - Microsoft: Smart Card or other certificate
 - Microsoft: Protected EAP (PEAP)
 - Cisco: LEAP
 - Cisco: PEAP
 - Cisco: EAP-FAST
 - Microsoft: EAP-TTLS

Email Configuration

Figure 11-18 Email Configuration

Enter your **Account Settings** (**Your Name, Email Address, Reply-to-Address, User Name, Password, Server Name, Port, Connection security, Authentication method**) as desired. Select **Advanced Configuration** to switch between simple and advanced configuration parameters or press **Clear Settings** to clear all entered data.

Define your **Message Defaults & Signature** (**Subject, Message, Signature, Use HTML**) and **Options** (Max. **Email Size, Keep sent mails in Mail Queue**) as desired.

11.1.4.2.3 Archive Configuration

1. Change the settings as needed or click **Default** to discard the adjustments and return to default values.
2. Click **Save&Return** to save the adjustments and return to the previous menu.

Compression Rate

Ultrasound images are consuming a lot of the system's memory resources. Therefore, the JPEG - compression method can be applied to the images to reduce their size. When selecting a JPEG - compression less than 100% a message appears.

Note **Volume Wavelet Quality** is only enabled if the volume compression is set to **Wavelet Lossy**.

If the volume contains color information, the color part of the volume is compressed with a setting that is 5 points better than the selected setting, e.g. Setting Mid: color compression High, grey compression Mid

If a volume is compressed using lossy wavelet compression, a yellow sign (Wxx; xx = compression factor, e.g. W9) is added when reloading the image.



A lossy compression reduces image quality, which can lead to a false diagnosis!

11.1.4.3 Button Configuration

The following buttons can be configured for performing specific functions:

- P1-P4
- C1-C4
- Start Exam

- End Exam
- Freeze

11.1.4.3.1 P1-P4 Keys

There are two different tabs, **Overview** and **Detailed Setup** available, for example P1:

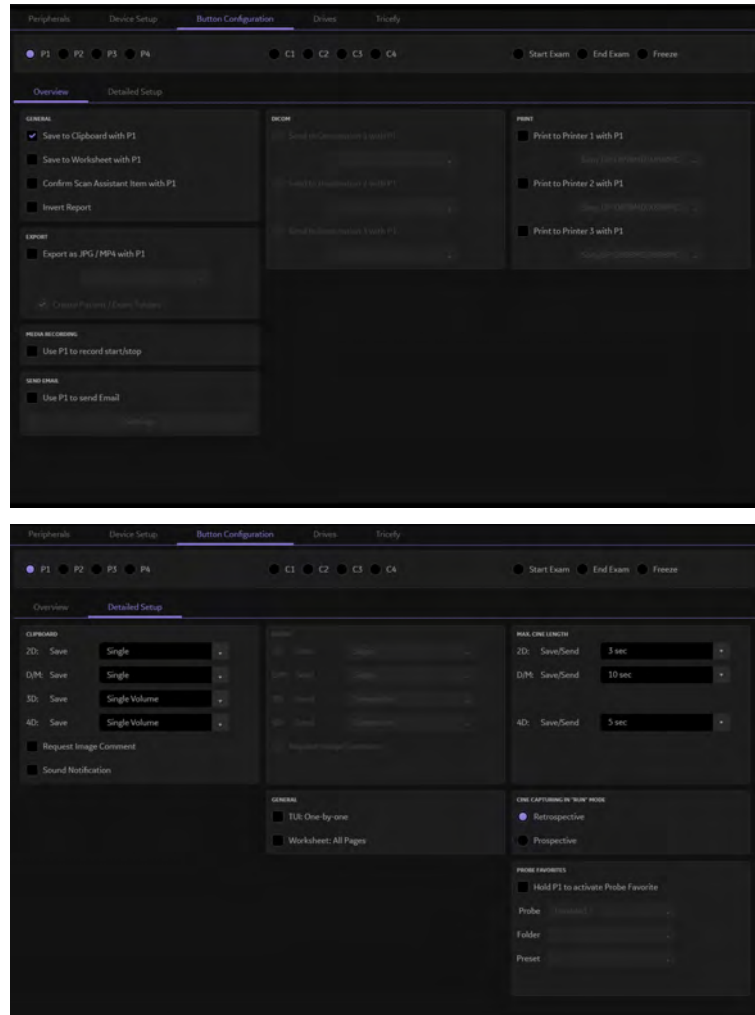

1. **Overview:** Select the basic actions to be performed when pressing a particular P - key.
2. **Detailed Setup:** Choose what exactly happens when a P - Key is pressed. (i.e.: If you choose to save images in the **Overview** - tab, then the format of the images to save can be selected in the **Detailed Setup** - tab.)

Overview

Save to Clipboard with Px	Copy image data from the monitor to the clipboard.
Save to Worksheet with Px	Save image data from the monitor to the worksheet.
Confirm Scan Assistant Item with Px	Confirm a current selected check item.
Invert Report	Invert report page option for archive or Dicom send
Export as JPEG / MP4 with Px	Allows to quickly export images and cine sequences from the US - Image area. When Create Patient / Exam Folders is selected, (sub)folders are created (only when Export as JPEG / MP4 with Px is enabled).
Use Px to send Email	Send image data by email. If this box is checked, all other configuration possibilities are deactivated. Settings becomes available for detailed Email configuration.

Use Px to record start/stop	Use it as Recorder control. If this box is checked, all other configuration possibilities are deactivated.
DICOM	Send data to a DICOM destination (1-3). The drop down list contains all available DICOM Store destinations.
Print	Print data on Printer 1-3. The drop down list contains all available printers (DICOM and other printers).
Probe Favorites	<p>Check Hold Px to activate Probe favorite to activate the Probe Favorite function, which allows to enable the desired Probe, Folder and Preset by holding the Px button configured in the Button Configuration.</p> <p>As long as the probe is connected and the function activated, an icon with the picture of the probe and the selected application is displayed. The Probe Favorite function disappears when the probe is disconnected until it is connected again.</p>

Detailed Setup

2D Save	<p>Automatic:</p> <ul style="list-style-type: none"> ● Saves data that is displayed on the screen. ● Saves a single 2D image in Freeze Mode. ● Saves Cine in Auto Cine Mode as defined in Auto Cine Menu. ● Saves Cine according to the Max. Cine Length setting in Write Mode. <p>Single: Always saves single 2D images independent of the selected mode.</p> <p>Cine: Always saves 2D Cine.</p> <ul style="list-style-type: none"> ● Saves Cine according to Max. Cine Length setting in Write- and Freeze - mode. ● Saves Cine in Auto Cine Mode as defined in Auto Cine Menu.
D/M Save	<p>Single: Saves single images containing both, current D/M data and current 2D data.</p> <p>Cine: Saving 2 cines, one containing D/M data, the other containing 2D data.</p>
3D Save	<p>Automatic:</p> <ul style="list-style-type: none"> ● Saves 3D Volume that is displayed on the screen. ● Saves 3D and Rot. Cine in 3D Rot. Cine Mode. ● Saves 3D Static without Rot Cine in normal 3D Mode. <p>Single Volume: Saves 3D Volume data.</p> <p>Screenshot: Depending on the settings in the Archive Configuration Dialog either TrueAccess or Screenshot / Multiframe is available.</p> <p>Sweep Cine: Saves/Sends the 3D acquisition sweep as DICOM image cine. When a 3D Sweep Cine is reloaded, the cine play back starts automatically.</p>
4D Save	<p>Automatic:</p> <ul style="list-style-type: none"> ● Saves data that is displayed on the screen. ● Saves a single 3D Static data set in Freeze Mode. ● Saves Cine in Auto Cine Mode as defined in Auto Cine Menu. ● Saves Cine according to the Max. Cine Length setting in Write Mode. <p>Single Volume: Always saves a 3D Static data set independent of the selected mode.</p> <p>Volume Cine: Always saves 4D Cine.</p> <ul style="list-style-type: none"> ● Saves Cine according to Max. Cine Length setting in Write- and Freeze - mode. ● Saves Cine in Auto Cine Mode as defined in Auto Cine Menu. <p>Screenshot: Depending on the settings in the Archive Configuration Dialog either TrueAccess or Screenshot / Multiframe is available.</p>
Request Image Comment	If selected, a window pops up every time an image is saved / sent, asking for an image comment.
Sound Notification	If selected and an image or cine was stored successfully to the clipboard, a sound is played by the system.

Worksheet: All Pages	If selected, the system prints, sends and/or saves all available Worksheet pages.
TUI: One-by-one	If selected, the system prints TUI images one-by-one and an additional overview image. This selection is also applied when data is saved to Archive, sent to a DICOM Server or DICOM Printer or normal Windows® Printer. It is not available for the B/W video printer.
Max. Cine Length	Select the desired Cine length settings for Save and Send. A pull down menu is available but the length can also be adjusted with a direct input from the AN keyboard (numbers 0-9).
Cine Capturing in "Run" mode	Select either Retrospective or Prospective as Cine Capturing Mode.

11.1.4.3.2 C1-C4 Keys

C-Buttons are four configurable keys for easier handling with often used functions. If a C-Button is configured, these controls are displayed permanently in the Head Up Display monitor area.

Following functions are configurable:

- None
- Archive
- Abc: Keyboard
- B-Flow
- Biopsy Line On/Off
- Biopsy menu
- Bodymark
- Contrast
- CW
- DICOM Spooler
- DVR Menu
- DVR Record
- Elasto
- HD-Flow
- Histogram (Open menu)
- Home
- Open Protocol
- Preset Save
- Save Screens to USB
- Probe Menu
- Report
- Save/Send Print (an extended configuration view, same as for P-Buttons, is visible)
- Scan Asst. Confirm
- Scan Asst. Next item
- Scan Asst. Next Group
- Scan Asst. Pause
- Scan Asst. Prev. Item

- Scan Asst. Prev. Group
- Asst. SonoLystIR On/Off
- SonoLystlive On/Off
- TD
- Transfer Measurements
- VCI-A
- XL/Full Screen (toggle between Std./XL/Full Screen)
- XTD

11.1.4.3.3 Start Exam

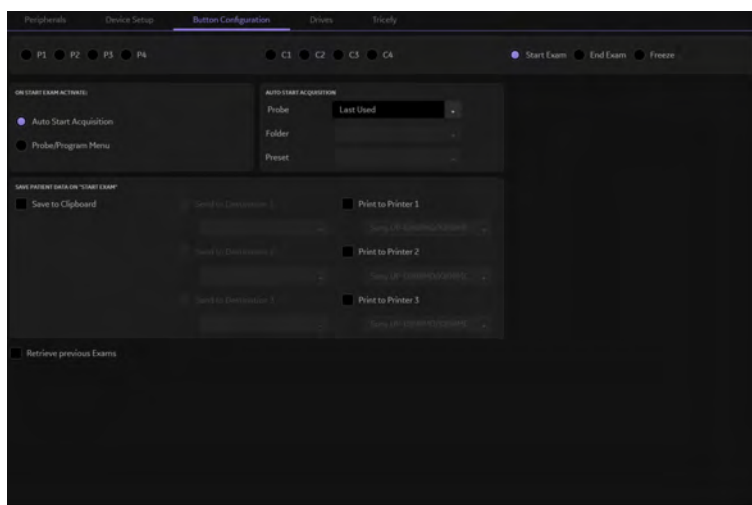

Figure 11-19 Start Exam

Overview

On Start Exam Activate:

Select between:

- **Auto Start Acquisition:** the system automatically starts a new acquisition in 2D Mode when **Start Exam** is pressed.
- **Probe/Program Menu:** the system automatically shows the Probe select menu when **Start Exam** is pressed. The image on screen is cleared (no image visible).

Auto Start Acquisition

The following settings can be adjusted:

- **Probe: Last used** or **Probe x** (all connected probes)
- **Folder:** All available Folders
- **Preset:** All available Presets from the selected Folder above

Save Patient Data on "Start Exam"

Select between:

- **Save to Clipboard:** Saves a screenshot of the Current Patient Data to Clipboard by pressing **Start Exam**.
- **Send to Destination 1-3:** Sends a screenshot of the Current Patient Data to the selected destination by pressing **Start Exam**.
- **Print to Printer 1-3:** Prints a screenshot of the Current Patient Data on the selected printer by pressing **Start Exam**.

Probe	Activates the selected probe (if auto start is selected).
Retrieve previous exams	Check to retrieve measurement data from previous exams and add them to the archive. This function has to be enabled in the DICOM Configuration STR.REPORT (Structured Report) first.
Note	<i>DICOM Retrieval of measure data from past exams includes originally transferred data only. Any changes made after transfer cannot be retrieved.</i>

11.1.4.3.4 End Exam

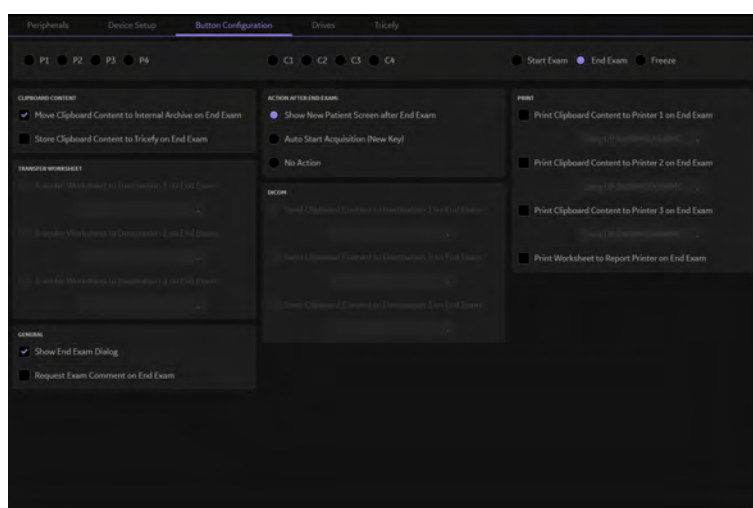

Figure 11-20 End Exam

Overview

Move Clipboard Content to Internal Archive on End Exam	Select to store the complete clipboard content in the internal archive when the End Exam button is pressed.
Transfer Worksheet to Destination 1-3 on End Exam	Select to automatically transfer the worksheet contents to a remote server when the End Exam button is pressed. Use the drop down menu listing all available destinations to select the desired remote destination.
Show Exam End Dialog	If this box is selected a dialog message is shown on screen when the End Exam button is pressed.
Request Exam Comment on End Exam	If selected, a window pops up every time an exam is ended, asking for an exam comment.
Show New Patient Screen after End Exam	Select to automatically display the “Current Patient” screen after an exam was ended to start a new patient.
Auto start Acquisition (New Key)	If this radio button is on, the system automatically starts a new acquisition with the Auto Start Acquisition settings when End Exam is pressed.
No Action	If this radio button is on, the system doesn’t do any action concerning Start Exam procedure.
Send Clipboard Content to Destination 1-3 on End Exam	Select to send the complete clipboard content to a DICOM destination on End Exam . The drop down list contains all available DICOM Store destinations.
Print Clipboard Content to Printer 1-3 on End Exam	Select to print the complete clipboard content on the selected Printer on End Exam . The drop down list contains all available printers (DICOM and other printers).
Print Worksheet to Report Printer on End Exam	Select to automatically print the worksheet (if available) in the report printer.

Note *If the **Move Clipboard Content to Internal Archive on End Exam** check box is not set, there is no possibility to save the clipboard content.*

11.1.4.3.5 Freeze

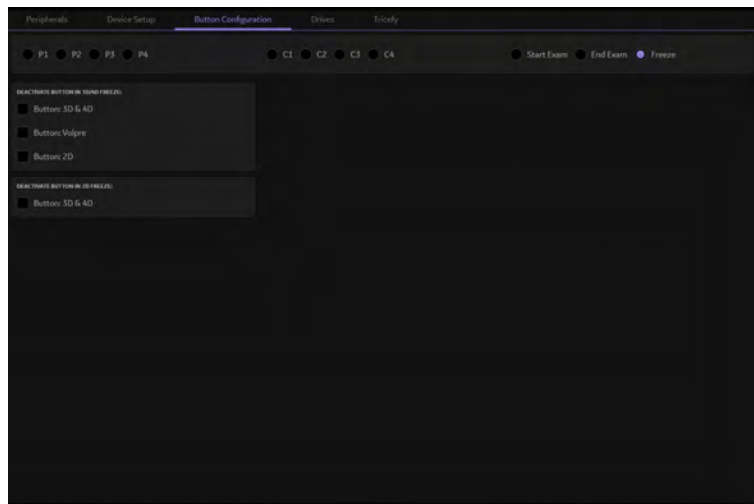

Figure 11-21 Freeze

Overview

Select which buttons to activate/deactivate on 3D/4D Freeze:

- Button: **3D & 4D**
- Button: **Volpre**
- Button: **2D**

Select which buttons to activate/deactivate on 2D Freeze:

- Button: **3D & 4D**

All the buttons checked are disabled (grayed) only in Freeze mode, not in Run mode.

11.1.4.4 Drives

This overview shows all connected USB-, Network-

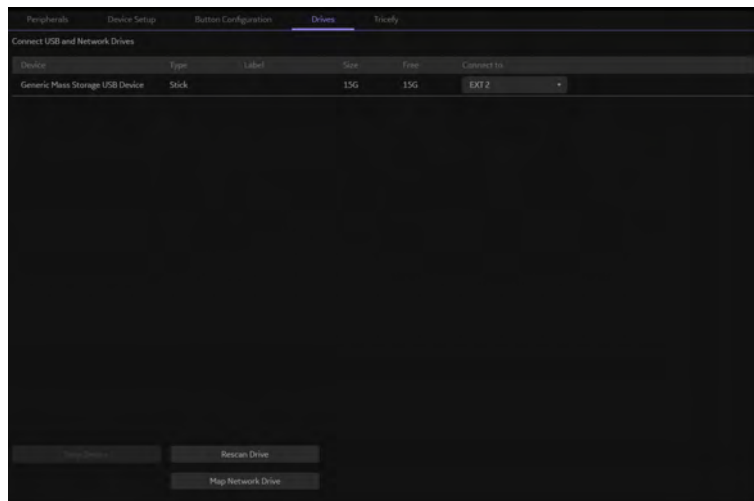

Figure 11-22 Drives

Controls

Stop Device	Disconnects USB drives for secure unplug.
Rescan Drive	Rescans the system to search for not recognized USB-Drives. A message dialog appears guiding through the process and showing progress.
Map Network Drive	Press to connect a network drive. Enter the Network folder Name , User and Password and choose whether to connect automatically.

11.1.4.5 Device Mgmt

Note This tab is only visible when the option is set.

The configuration of the Device Mgmt tab is the precondition for the remote device management tool that allows bi-directional device management capabilities.

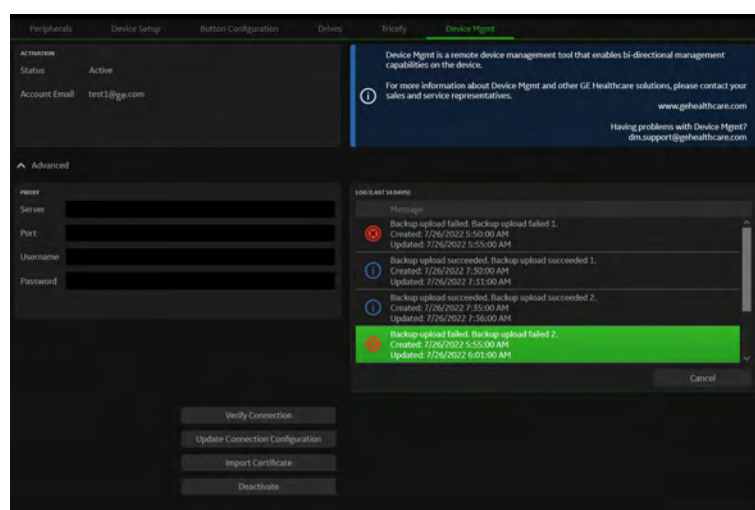

Figure 11-23 Device Mgmt (example)

A connection status is displayed. If inactive, fill in the corresponding fields within **Activation** to set up a connection to the remote device management server.

- **Activate:** Start the activation process. It is possible to enter/edit proxy settings within the **Advanced** section.
- **Deactivate:** Deactivate an already existing activation.
- **Verify Connection:** Check/verify the connection.
- **Update Connection Configuration:** Send updated entries to the connection server.
- **Import Certificate:** If pressed, a dialog to import a new certificate used for connecting to the cloud (same as import certificates for DICOM) appears.

Within the **LOG (Last 14 Days)** field error messages and success messages are displayed. If an error appears during the backup up-/download, the system tries again until the upload is successful. Press **Cancel** to stop the system from trying to update.

11.1.5 Security

Security includes:

- **Authentication**
- **Disk Encryption** (optional)
- **Whitelisting** (optional)
- **System Password**

11.1.5.1 Authentication

There are two possibilities for Authentication:

- password protected access to authentication functions (the System Admin Password has to be entered)
- direct access to all authentication functions

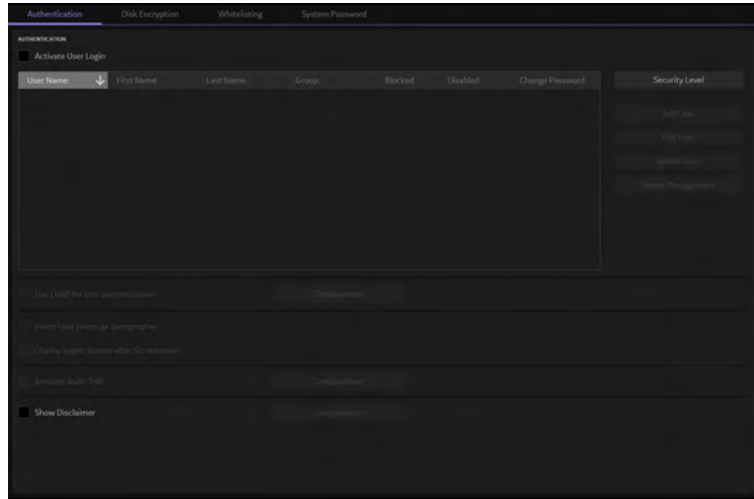

Figure 11-24 Tab Authentication - Direct Access (example)

Controls

Activate User Login

Check to activate the user login function.

- Click **Add User** to add a new user. A dialog appears. Enter the **User Name**, the **First Name** and the **Last Name**, select a **Password** and confirm it and choose the **Group** the user should belong to.

Note *A valid password must be at least 6 characters long and has a maximum length of 80 characters. A password must contain at least 2 non-letter characters, 0...9 or ! @ # \$ % ^ * ().*

- Select an already existing user. Click **Edit User** to edit data.
- Select an already existing user. Click **Delete User** to delete the user. Confirm with **OK** or press **Cancel** if you do not want to delete the user.
- Click **Group Management** to open the configuration dialog. Select a user group from the **Group Name** list to display the **Permissions** (i.e. **Archive**, **Export**, **System Setup**,...) of the group. Furthermore **Permissions** can be granted to access and change certain items by checking the fields available.

Click **Add Group** to add a new group (a dialog for entering a new group name appears) or **Delete Group** to delete an already existing group (a confirmation dialog appears).

- Press **Security Level** to open the Security Level configuration dialog. Edit the security and password settings (also see 'Authentication' on page 11-40) as desired. Each user has to follow the rules defined.

Security levels available:

- Lowest
- Medium
- High (Recommended)
- DISA STIG Compliant
- User Defined

Use LDAP for user authentication	<p>Check to activate the LDAP (Lightweight Directory Access Protocol) for user authentication. The user password and depending group permissions can be received from a LDAP server.</p> <p>Click Configuration to open the configuration dialog:</p> <ul style="list-style-type: none"> • Enter the desired Server Address or choose one from the Lookup list (all available domains are listed there). • Enter the Server Port (default: 389), check whether to Use TLS (TLS transfer encryption) or not, enter the Domain and the DN for User (Distinguished Name for User). Press the button next to the DN for User field to edit the settings. • LDAP User mapping: Enter the First Name and the Last Name or edit the settings by pressing the button next to the input fields. • LDAP Group mapping: Select an existing group and press the button next to the list to edit the settings for the selected group as desired (i.e. apply a DN for Groups or a Filter for Groups,...) • Click Test Connection to display the LDAP connection result. • Click Advanced Configuration to configure the settings in a more detailed way (i.e. enable Two step authentication and further settings).
Insert User Name as Sonographer	Check if you want to insert the user name as sonographer.
Display Logon Screen after Screensaver	Check to display the login screen after the screensaver.
Activate Audit Trail	Check if you want to log the audit trail data.
Show Disclaimer	If checked the system displays a disclaimer as soon as the user login appears. Press Configure to open the Disclaimer Configuration Dialog. Enter the desired text and click OK to save the changes or Cancel .

System Login

The system login window appears as soon as the system is started or a current user logs off. The correct user name and password has to be entered to login. If the correct password/user name combination is entered, it is also possible to change the password. The **Emergency** button enables to use the system in emergency mode with restricted access.

Emergency Mode

- no access to the system setup
- no access to the Archive
- search function and Worklist view are disabled in the patient archive.

Message dialogs appear in the restricted areas to inform about the restricted access and to guide back to full functionality by entering the correct password.

System Logoff

To log off or lock the system, press the standby button. The screen displayed offers several possibilities:

- **Log off**
- **Lock** the system
- **Shut down**
- **Restart**
- **Cancel**

Password policies

Password security settings to be selected:

1. password length: 6-64 characters

2. no username allowed within the password
 3. no sequential or repeated characters with a minimum length of 3 characters allowed (i.e. no "aaa", "abc", "123",...)
 4. password has to differ from the previous one in at least xx characters
 5. minimum number of xx upper case letters required
 6. minimum number of xx lower case letters required
 7. minimum number of xx digits
 8. minimum number of xx symbols (i.e. ~, #, \$, ...)
 9. minimum password age (xx hours): The current password has to be at least xx hours old before a change is possible.
 10. maximum password age (xx days): If the maximum age is reached, the user has to change the password.
 11. password reuse history count: The password has to be different from the last xx passwords.
- Account security settings to be selected:
1. failed login before account gets blocked: After xx times of failed logins, the corresponding user is blocked for a defined time.
 2. failed login account block time: After xx times of failed logins the user is blocked for a defined time. After this time is over, the user is able to login again.
 3. account inactivity block time (days): After xx days of inactivity the user is blocked (can only be removed by the administrator).
 4. session auto logoff time: The user is logged off automatically after a defined time of inactivity (only in **Freeze** mode).
- Further possibilities:
1. **Change of password:** As soon as a user tries to login the next time the change password dialog appears. It is not possible for this user to login until the password is changed.
 2. **Disabled:** If this is checked, the affected user is not able to login or change the password anymore. If the user tries to login, a message appears, that this user is disabled.
 3. **Blocked:** If the user is blocked (because of the account security settings), this checkbox is checked automatically. The affected user is not able to login or change the password. If the user tries to login, a message appears that this user is blocked.

11.1.5.2 Disk Encryption

Caution



Without the Encryption Password or Recovery Key it will not be possible to access the Ultrasound device including emergency mode, scanning, patient information, images, or local archive. GE HealthCare has no access to this information or the ability to undo encryption in the event that the Encryption Password and Recovery Key are lost. The security and safety of the Encryption Password and Recovery Key is solely the user's responsibility.

- Note** *Disk Encryption is an option and might not be available in all countries. If the option is not set, the tab **Disk Encryption** is not available in the System Setup-Administrator. If the option is set but not activated, a message appears during bootup. Follow the instructions displayed, otherwise confirm twice that you no longer want to be informed about this inactivated security feature.*
- Note** *A system without the option but with encrypted disk is unlock-able.*
- Note** *The feature is using BitLocker configured with AES encryption using 256 Bits key length.*

Disk Encryption enables an encryption to secure all Patient Data, Patient Images and corresponding measurements. A password, a USB storage device with unlock key or the recovery key is necessary to unlock the device during the boot-up process.

Workflow

1. Set Password
2. Create unlock keys
3. Save or print recovery key and the optional USB key
4. Start encryption

Controls - Disk unprotected

Info badge	The info badge describes the Disk protection status and follow up steps.
Set unlock password	<p>Enter a password.</p> <p>Note <i>The password has to be of min. 6 characters and contain at least 2 digits. If a Security Level is active, the password has to meet password policies set in the User Authentication menu. If the password does not meet the policies, a message appears.</i></p>
Create unlock keys	<p>If no password is entered this button is disabled.</p> <p>Press Create unlock keys to create the USB and recovery keys. The system does a password validation.</p> <p>If the password</p> <ul style="list-style-type: none"> ● does not match with the retype password, an error message appears and the password needs to be retyped. ● is too short, an error message appears and a password with the correct length has to be entered. <p>Note <i>If the password policies are not met, the violated policies are listed.</i></p>
Identifier key	Created by the system.
Recovery key	Created by the system.
Save recovery key	Saves the identifier and recovery key to an external or network device.
Print recovery key	<p>Press to print the identifier and recovery key to a connected printer. If no printer is connected this button is disabled.</p> <p>The printout contains the following content:</p> <ul style="list-style-type: none"> ● Voluson Signature x ● Serial Number ● Identifier key ● Recovery key
Save USB unlock key	<p>The USB unlock key is created by the system.</p> <p>Press this button to save the USB unlock key to a connected USB device.</p> <p>This button is only active if a external device is selected.</p>
Start encryption	<p>Press this button to start the encryption. A pop-up window appears. Select Yes to start the encryption. Select No to close dialog without starting the encryption.</p> <p>If the identifier and recovery key are not printed or saved an error message appears.</p>
Progress bar	<p>Is displayed to show the current progress of the encryption</p> <p>Note <i>If the system is restarted without a complete encryption, the encryption process is resumed and a message displaying its progress appears.</i></p>

Controls - Disk protected

Change password	<p>Press button to unlock the password enter fields Set unlock password and retype password.</p> <p>Note <i>The password has to be of min. 6 characters and contain at least 2 digits. If a Security Level is active, the password has to meet password policies set in the User Authentication menu. If the password does not meet the policies, a message appears.</i></p> <p>The password is not visible.</p>
Save password	<p>Press Save password to save the newly entered password. If the password does not match with the retype password, an error message appears and the password needs to be retyped. If the password is too short, an error message appears and a password with the correct length has to be entered.</p> <p>Note <i>If the password policies are not met, the violated policies are listed.</i></p>
Change recovery key	<p>Opens a pop-up window. Press Yes to generate a new identifier and recovery key or No to close the dialog without generating new keys.</p>
Change USB key	<p>Opens a pop-up window. Select Yes to create a new USB key or No to close the dialog without generating an USB key.</p>

Unlock

The disk can be unlocked with one of the following possibilities:

- USB device with unlock key
- Password
- Recovery key

The system is automatically unlocked during the system bootup, if the correct USB device with unlock key is connected. If no correct key is connected a dialog appears.

Password	Enter the password.
Recovery key	Press the button to the recovery key dialog. Enter the recovery key.
Unlock	<p>Press Unlock to unlock the disk. If the password or the recovery key are incorrect an error message appears.</p> <p>Note <i>If the correct USB device with unlock key is connected in the meantime then the Unlock button unlocks the disk.</i></p>

Decrypt

Disk decryption is possible in the Service tools using the **Decrypt Disk** button. For further information also see: 'Service' on page 11-19

Note *The progress bar shows the progress of the decryption. If the system is restarted without a complete decryption, the decryption process is resumed and a message displaying its progress appears.*

11.1.5.3 Whitelisting

Note ***Whitelisting** is an option. Only if the option is set, the tab **Whitelisting** is visible. If the option is set but not activated, a message appears during bootup. Follow the instructions displayed, otherwise confirm twice that you no longer want to be informed about this inactivated security feature.*

Whitelisting prevents the system from installing unwanted Software. Before **Whitelisting** can be used a password has to be defined.

Note *The password has to be of min. 6 characters and contain at least 2 digits. If a Security Level is active, the password has to meet password policies set in the User Authentication menu. If the password does not meet the policies, a message appears.*

When **Whitelisting** is activated, a printer can only be installed after the user confirms it with the **Whitelisting** password.

Controls

Whitelisting active

Info badge The Info badge displays the current state of the **Whitelisting** including a short description how to continue.

Password The entered password is not visible and has a minimum of 8 characters.

Verify Password Enter the same password as in **Password** to activate **Whitelisting**.

Activate Activates Whitelisting. If **Password** or **Verify Password** are empty, **Activate** is disabled. Error messages appear when **Password** and **Verify Password** do not match or are less than 8 characters long.

Whitelisting inactive

New Password The entered password is not visible and has a minimum of 8 characters.

Change Password Press to change password. If the password change is successful, a message is displayed. **Change Password** is disabled, if **Password**, **New Password** or **Verify Password** are empty. Error messages appear, when entering a wrong password, **New Password**, and **Verify Password** do not match or are less than 8 characters long.

Deactivate Deactivates Whitelisting. **Deactivate** is disabled, if **Password** is empty. An error message is displayed, if the wrong password was entered.

Activate Whitelisting - Workflow

1. Enter **Password** and **Verify Password**.
2. Press **Activate** to activate **Whitelisting**.
3. Reboot the system to activate **Whitelisting**.

Note *If the device is not restarted and the user tries to install a printer, a message to reboot the system appears.*

Deactivate Whitelisting - Workflow

1. Enter **Password**.
2. Press **Deactivate** to deactivate **Whitelisting**.
3. Reboot the system to deactivate **Whitelisting**.

Note *If the device is not restarted and the user tries to install a printer, a message to reboot the system appears.*

11.1.5.4 System Password

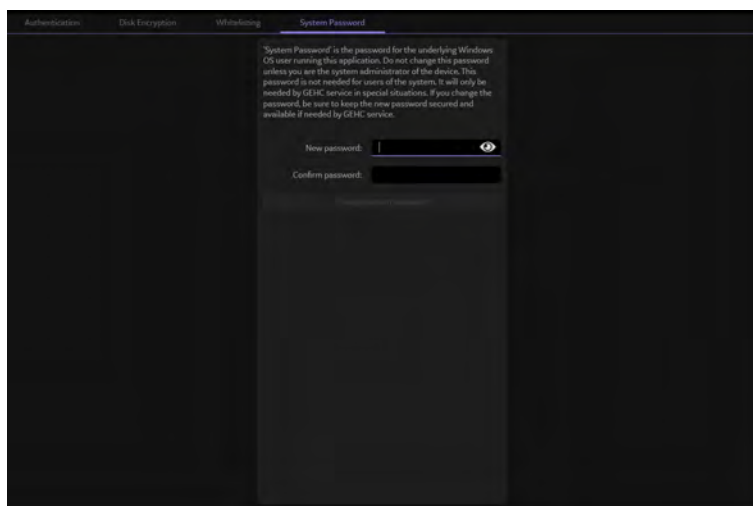

Figure 11-25 System Password

To change the password, enter the current password in the **Old Password** box (if the current password is the predefined system password, it is entered by the system automatically).

Enter a new password in the corresponding **New password** box and confirm it by typing it again in the **Confirm password** box. Press **Change system password** to save the changes.

Note *The password has to be of min. 6 characters and contain at least 2 digits. If a Security Level is active, the password has to meet password policies set in the User Authentication menu. If the password does not meet the policies, a message appears.*

11.1.6 Backup

The Backup function is the only tool to backup and reload the **System Configuration** containing all system settings like user presets, annotations, setup parameters (DICOM configuration, measure setup, network settings, etc.) and **Image Archive** containing all image data, measure data and patient data.

A backup can only be started without an exam or reloaded data set being open .

11.1.6.1 Configuration Backup

The **Configuration Backup** contains all system settings like user programs, text auto, setup parameters (DICOM configuration, measure setup, network) etc.

1. Enter the System Setup via the **Home** menu, select **Backup** and then go to the tab **Configuration backup**.
2. Select between:
 - **Save** (opens the save dialog)
 - **Load** (opens the restore dialog)
 - **Delete** (opens the delete dialog)

Controls

Destination	Select the desired destination for storing the backup: <ul style="list-style-type: none"> ● internal HDD ● Network (only available when a network drive is mapped) ● external USB drive (only available when an external USB drive is connected) ● Cloud (only available if the corresponding options are set and the Device Mgmt is configured; This backup can only be loaded on the device on which it was created.) ● Upload for Fleet (only available if the corresponding options are set and the Device Mgmt is configured; The backup is stored in the cloud and provided for the fleet management. This backup can be distributed to other devices.)
Save in / Load From	Select the desired USB device / network from the list of available locations.
New Folder	Creates a new folder in the directory selected.
Needed Space / Free Space	Displays the space needed for a backup and the free space available on the selected directory.
File Name	Enter a file name for saving a backup.
Optional Description	Enter a description for saving a backup.
Description	Displays the user defined description together with: <ul style="list-style-type: none"> ● creation date ● serial number of the creation device ● system type of the creation device ● software version of the creation device
Recommended Password	It is possible to enter a password to encrypt the backup if desired.
Confirm Password	Enter the password a second time to confirm it.
Enter Password	A password has to be entered to restore a backup (only available when a password was defined for a backup before).
Save	Saves the backup to the desired location (only when enough space is available) and displays the progress of the backup. If an error appears during the save process, a message appears.

Load Restores the selected backup from the backups available. A configuration tree is displayed listing all available items of the selected backup on the left side. Select the desired items to restore and move them to the right side by pressing >>.

Note *It is possible to sort the backup files from A-Z and Z-A by clicking onto the column header of the display.*

Press **Load now** to start the restore process or **Cancel** to cancel it. After successful loading or if an error appears during the restore process, a message appears. It also informs that the system has to be rebooted. By pressing **OK** the system reboots automatically.

Note *If the backup selected contains a configured system administrator and Security Data is selected for restore, a dialog appears asking for the authentication password. Only if the correct password is entered restoring a backup can be started.*

Note *It is not possible to load a V930 backup into an actual system.*

Delete Deletes the selected backup from the backups available. Confirm with **OK**.



There is no “undo” function for this action!

Cancel Closes the dialog without saving any changes.

Note *It is possible to have the hardware checked before exporting a backup. Access the shortcut menu and select **Export system state**. Confirm with **Yes** to check the hardware or select **No** to cancel and to display the Export System State dialog.*

When the Export System State backup is performed, 2 backup files are saved:

- *.v7z (voluson configuration backup)
- *.e7z (export backup)

Load a backup from the Cloud

If a backup is available, a symbol is displayed in the status bar. A click onto the symbol opens a dialog giving information about the backup (i.e. status, name, comment,...) and also shows whether it is mandatory or not. If loading of such a backup was successful, the corresponding backup is stored on the internal HDD for restore.

For optional backups either press **Discard** to discard the loading of the backup or **Load** to open the corresponding backup window and to progress with the backup.



Do not disconnect an external USB - device without stopping it. Disconnecting without stopping can lead to data loss on the external device.



All settings and patient data created since last full system configuration backup are **NOT** backed-up! It is highly recommended to create a full system configuration backup of settings and patient data regularly.

There are circumstances where it is not possible to load (restore) all the data. The following rules specify the restrictions:



1. Options can only be restored on the same Voluson™ Signature 18 / Voluson™ Signature 20 system within the same major software version.
2. When loading a backup into a system with a software version that has a higher major number (10.x.x -> 11.x.x), the following items will not be restored:
 - User Settings
 - Options
 - State of the Service platform (new model type necessary for VOLC)
3. The **user is only** allowed to restore data onto the same system if and only if the software version on this system is equal or higher than the version in the backup.
4. The **user is not** allowed to restore the following items to a different system:
 - Biopsy line positions and angles
 - Service Platform
 - Connectivity (Network settings, DICOM configuration, Trice settings,)
 - Service (Service platform settings)
 - Options (Software feature options)



The data from the backup always replaces the corresponding data on the Voluson™ Signature 18 / Voluson™ Signature 20 system.

11.1.6.2 Image Archive

The **Image Archive** contains all image data, measure data and patient data.

1. Enter the System Setup via the **Home** menu, select **Backup** and then go to the tab **Image Archive**.
2. Select between:
 - **Save Image Archive** (opens the save dialog)
 - **Load Image Archive** (opens the load dialog)

Save Image Archive controls

Save Dialog

All exams	Select the period of time until when the exams should be backed up: <ul style="list-style-type: none"> ● To date ● Older than 1 day ● Older than 1 Week ● Older than 1 Month ● Older than 1 Year
Remove Local Images after Backup	If checked all images are removed from the local archive after the backup was done successfully.
Advanced	Opens the Advanced Exam Select dialog.
Back	Goes back to the previous dialog window.
Next	Goes forward to the next dialog window.

Cancel	Goes back to the Back to backup start page .
Advanced Exam Select Dialog	
Patient View & Exam View	All exams from a patient are listed (if more than one exam is available) including column descriptions.
Include All	All items are checked.
Exclude All	All items are unchecked.
Include Selected	All selected items are checked.
Exclude Selected	All selected items are unchecked.
AN Keyboard: CRTL + Set	Selective selection of items to check/uncheck.
AN Keyboard: Shift + Set	Selection of a whole block of items to check/uncheck.
Back	Goes back to the previous dialog window.
Next	Goes forward to the next dialog window.
Cancel	Goes back to the Back to backup start page .
Sort function	All buttons with an arrow icon on the right can be pressed to change the sort criteria from up to down or vice versa.
Save Image Archive Backup Dialog	
Radio Network	Select the network drive as the target/source location.
Radio Extern USB Drives	Select an externally connected USB drive in the range.
Backup description	Additional text file used to describe the backup and stored with the backup file (max. 128 characters).
Backup data size	Total Size of Backup data
Disk Capacity	Disk capacity of used disk (only displayed when DVD/CD is selected)
New disks needed	Number of disks needed to save the selected backup data (only displayed if DVD/CD is selected)
Free Space	Free space on target device
Back	Goes back to the previous dialog window.
Next	Goes forward to next dialog window Start Backup .
Cancel	Goes back to the Back to backup start page .

Saving an Image Archive:

1. Open the save dialog.
2. Select the images to be saved and the desired target location for the backup.
3. Press **Start Backup**. A new dialog window appears. Press **Yes** to start the backup and to display the progress of it or **No** to cancel. After a successful backup a message appears. Press **OK** to confirm.

Load Image Archive

All controls are the same as in the **Save Image Archive** dialogs.

Loading an Image Archive:

1. Open the load dialog.
2. Select the images to be loaded.
3. Press **Next** to open the **Start Restore Backup** window. Press **Yes** to start the restore backup and to display the progress of it or **No** to cancel. After a successful backup a message appears. Press **OK** to confirm.

11.1.7 Imaging Presets

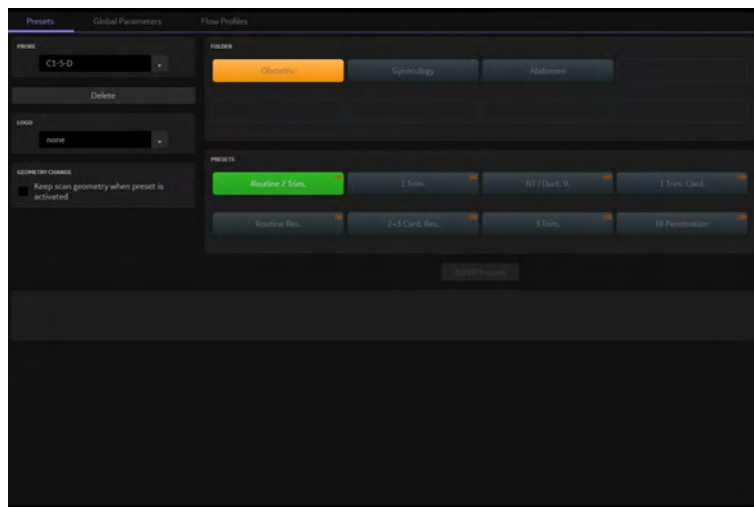

Figure 11-26 Imaging Presets

Setup

Preset folders and buttons can be moved, deleted, renamed and copied:

1. Select the **Setup** tab.
2. Select a probe from the drop down list.
The available folders and presets for 2D Mode will be displayed. Make sure that both a preset folder and button is selected in order to display all available functions. If a volume probe is selected, also the **3D/4D presets** button will be available.
3. Modify folders or presets:

Note *Moving via drag and drop, copying and cutting a preset folder is only possible for 2D presets but not for 3D/4D presets.*

Move

- Select a folder or preset button. Keep the left or right trackball button (**Set**) pressed to drag a folder or preset button from one position to another and release the **Set** button.

Copy

- Select a folder or preset button. Press the left trackball button (**Copy**).
- Move the trackball to the desired position and press the left or right trackball button (**Paste**).
- If the selected position is used for a different preset, a message window appears asking if you really want to overwrite the preset or folder. Select **No** if you don't want to overwrite the preset or folder. If you want to overwrite it, you can either overwrite the complete preset or only settings relevant for scan geometry.

Rename

- Select a folder or preset button. Press the right trackball button (**Rename**).
- Rename the folder or preset button.

Cut

- Select a folder or preset button. Press the top trackball button (**Cut**).
- Move the trackball to the desired position and press the left or right trackball button (**Paste**).

Delete

- Select a folder or preset button. Select the button **Delete**.
 - A message window appears asking if you really want to delete the folder or preset button.
4. Geometry change:
 - Tick the box if the scan geometry should not be changed when changing from one preset to another in run mode.

Global Parameters

Global parameters can be set for a specific application or for all applications. If parameters are set, they are used regardless of the selected preset.

1. Select the **Global Parameters** tab.
2. Select a specific application or select **General**.
If **General** is selected, all applications will be affected.
3. Modify the desired parameters by selecting from the drop down lists.

Flow Profiles

It is possible to adjust the values for the following **Flow Profiles**:

- Ut Art
- MCA
- Umb Art
- Duct Ven
- Pulm Veins
- Cardiac

It is also possible to set values for transvaginal probes and transabdominal probes.

If **Start measurement on Freeze** is selected, the depending **Flow Profile** measurement is started/opened.

11.1.8 Biopsy

For more information see 'Biopsy setup' on page 5-28.

11.1.9 Measure Setup

Note

Measurements added by the user can be transferred with DICOM SR if the corresponding application is transferable. Press **Create DICOM SR data** to create new DICOM data. If a user defined measurement already includes DICOM SR data, press **Edit DICOM SR data** to make changes. A window appears. Please note that the first two characters in the CSD textboxes must be "99" and the value in the CV textbox has to be unique in the whole network. It is not possible to save changes with invalid values. Press **OK** to save the changed values and to add the measurement to the structured report or **Cancel** to exit without saving the changes. DICOM SR data is included in small and full backup.

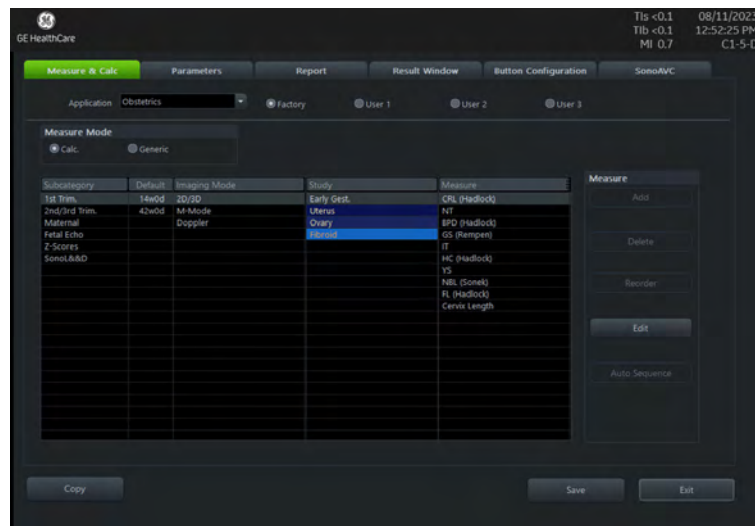

Figure 11-27 Measure & Calculation Setup (example)

Parameters

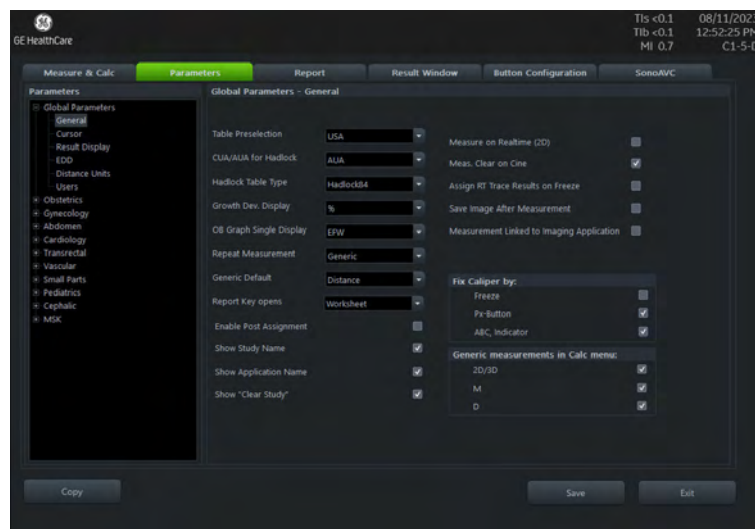

Figure 11-28 Parameters

1. Select the desired Parameter (i.e. **Global Parameters, Abdomen, Small Parts, Obstetrics,...**) and click onto the **+** next to it to open the menu. The corresponding configuration menu is displayed on the right side.
2. Select and adjust the desired settings as you prefer by choosing the desired options from drop down menus (i.e. **Post Assignment,...**) or by enabling/disabling them with the checkboxes available (i.e. enable an automatic change of the measure application according to the

selected probe application by checking **Measurement linked to imaging application** or select the generic measurements to be displayed (**2D/3D, M, D**) in the Calc menu).

Note *When reloading an older worksheet from a previous system, also the old parameter settings are displayed and not the newly defined ones.*

Global parameters - possible selections:

General	Define how to work with measurements (i.e. preselect a table, define generic default measurements, enable/disable post assignment,....).
Cursor	Define overall cursor details (i.e. size, color, display options,...).
Result Display	Define the result display details (i.e. size, color, position,....).
EDD	Define details about the EDD. Select the desired number of Pregnancy Days and whether to Show EDD calc. on screen .
Distance Units	Select the desired parameters by checking them and define the desired distance units (Unit, Precision, Average) for the whole application.
Rename Users	Define the desired user names.

Obstetrics- possible selections:

General	Define how to work with measurements (i.e. define what to do on freeze or whether to keep the result window, select calculation methods or the manual trace method, decide whether the author's name should be displayed or enable/disable Use Left/Right for Long Bones ,....).
EFW	Define the desired settings.
Auto/Man Trace	Define which parameters should be calculated when Auto Trace is used.
Calculation	Define which ratios / graphs or OB tables should be turned on or off or which tables should be shown.
AC/HC Configuration	Define the desired measure methods for AC and HC calculations.
NT/IT Configuration	Define default tools for NT and IT, select whether to change controls, display a magnification hint or clear graphics.
SonoBiometry Configuration	Define the desired settings (only available if the option is set).
SonoCNS Configuration	Define the desired settings (only available if the option is set).
Worksheet	Define the desired values for the Quad graph default configuration . If " " is selected, no default value is used.
Z-Score	Check the desired items (i.e. BPD, FL,...) on which the Z-scores should be based on in the Display Z-Scores based on: section. The calculated Z-scores based on the selected items are displayed in the report and the result window.
Note	<i>It is only possible to check / uncheck further Z-score values if the corresponding checkmark is set in the Display Z-Scores based on: section.</i>
Fetal Anatomy	Define the desired settings for Fetal Anatomy (i.e. Fetal Anatomy Preset, Group ,...)

Gynecology - possible selections:

General	Define how to work with measurements (i.e. define what to do on freeze or whether to keep the result window, select calculation methods or the manual trace method,...). Select the desired IOTA model. Select Yes whether you are in an Oncology Center. It is also possible to sort the 2D follicle measurements as desired. The 2D follicle measurements are displayed in the worksheet accordingly. Select the desired Fibroid Classification value to be displayed in the worksheet.
Auto/Man Trace	Define which parameters should be calculated when Auto Trace is used.
Calculation	Define the calculation parameters as desired.
Worksheet	Define the findings to be displayed in the worksheet (Show Findings, Show IETA Findings or Show AFC).
Pelvic Floor	Select the desired measurement sequence to be displayed (Rest or Stress).
Follicles	Define the desired settings for Follicles (i.e. Sort follicles by, Auto Caliper...). If Auto Caliper is checked, auto mode is selected automatically for follicle measurements. After clicking onto the US image an AI algorithm tries to find valid follicle structures and, if successful, performs the Double Caliper measurement automatically. If the AI algorithm cannot find a valid follicle structure, manual mode is activated.

Abdomen - possible selections:

General	Define how to work with measurements (i.e. define what to do on freeze or whether to keep the result window, select calculation methods or the manual trace method,...).
Auto/Man Trace	Define which parameters should be calculated when Auto Trace is used.
Calculation	Define the calculation parameters as desired.

Cardiology - possible selections:

General	Define how to work with measurements (i.e. define what to do on freeze or whether to keep the result window, select calculation methods or the manual trace method,...).
Calculation	Define the calculation parameters as desired.

Transrectal - possible selections:

General	Define how to work with measurements (i.e. define what to do on freeze or whether to keep the result window, select calculation methods or the manual trace method,...).
Auto/Man Trace	Define which parameters should be calculated when Auto Trace is used.
Calculation	Define the calculation parameters as desired.

Vascular - possible selections:

General	Define how to work with measurements (i.e. define what to do on freeze or whether to keep the result window, select calculation methods or the manual trace method,...).
Auto/Man Trace	Define which parameters should be calculated when Auto Trace is used.
Calculation	Define the calculation parameters as desired.

Small Parts - possible selections:

- General** Define how to work with measurements (i.e. define what to do on freeze or whether to keep the result window, select calculation methods or the manual trace method,...).
- Auto/Man Trace** Define which parameters should be calculated when Auto Trace is used.
- Calculation** Define the calculation parameters as desired.

Pediatrics - possible selections:

- General** Define how to work with measurements (i.e. define what to do on freeze or whether to keep the result window, select calculation methods or the manual trace method,...).
- Auto/Man Trace** Define which parameters should be calculated when Auto Trace is used.
- Calculation** Define the calculation parameters as desired.

Cephalic - possible selections:

- General** Define how to work with measurements (i.e. define what to do on freeze or whether to keep the result window, select calculation methods or the manual trace method,...).
- Auto/Man Trace** Define which parameters should be calculated when Auto Trace is used.
- Calculation** Define the calculation parameters as desired.

MSK - possible selections:

- General** Define how to work with measurements (i.e. define what to do on freeze or whether to keep the result window, select calculation methods or the manual trace method,...).
- Auto/Man Trace** Define which parameters should be calculated when Auto Trace is used.
- Calculation** Define the calculation parameters as desired.

Report

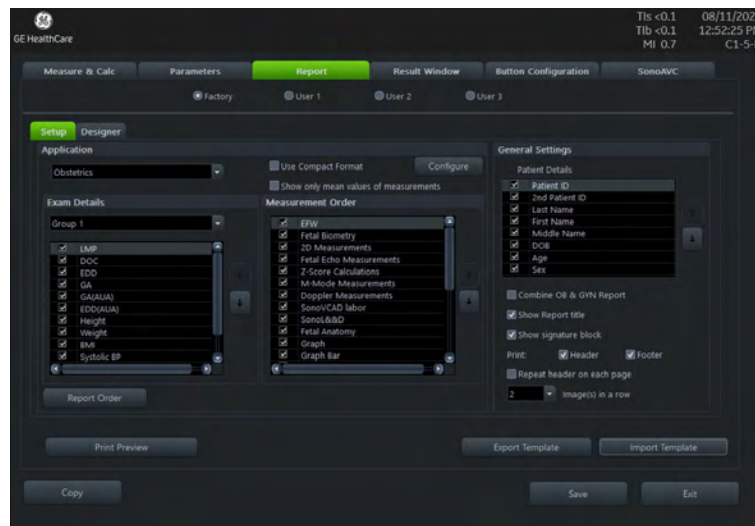

Figure 11-29 Report

1. Select the tab **Setup**.
2. Select an **Application**, **General Settings/Patient Details** and the desired number of **Images in a row**.
3. Edit the settings as you prefer.
4. Select the tab **Designer**.

5. Edit the settings (margin, font controls, quick parts, logo, header/footer) as you prefer.

Print Preview	Opens the print preview.
Export Template	Exports all settings to an external device (no CD/DVD).
Import Template	Imports an exported template from an external device.
Copy	Copies the Report Settings and/or Report Designer settings.
Save	Saves the changes made.
Exit	Leaves the menu.

Result Window

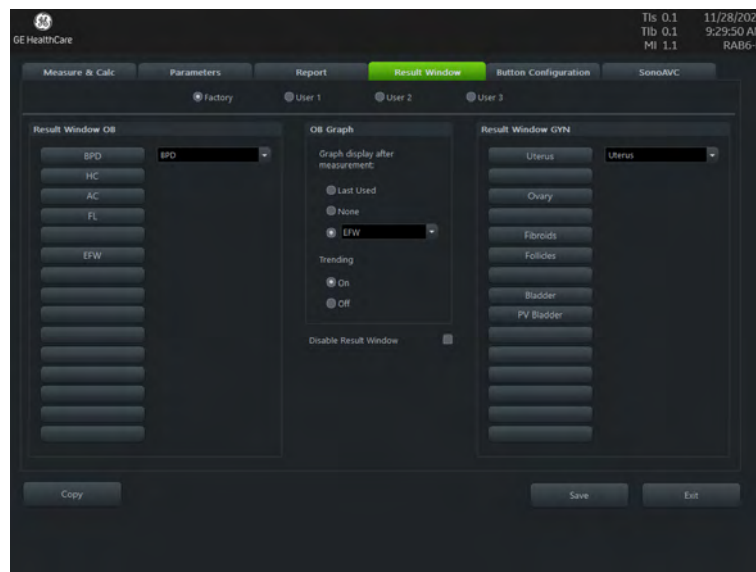

Figure 11-30 Result Window

1. Select the desired measurements and the graph display.
2. Edit the settings as you prefer.

Button Configuration

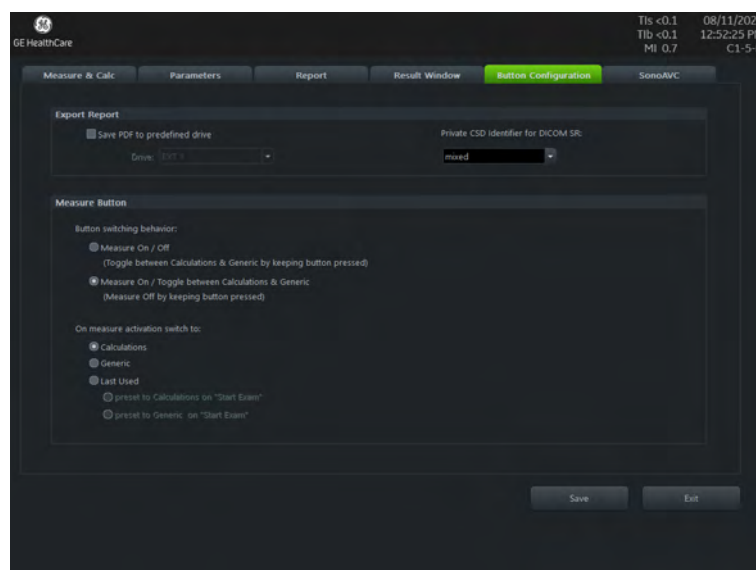

Figure 11-31 Button Configuration

1. **Export Report:** Select whether to save PDFs to a predefined location and choose the desired drive. Also define the **Private CSD Identifier for DICOM SR:** 99GEK, GEK or Mixed (used for old private tags (GEK) and newly entered private tags (99GEK)).
2. Configure the **Measure Button** as desired.
3. Press **Save** to save the changes and/or **Exit** to leave the menu.

SonoAVC™

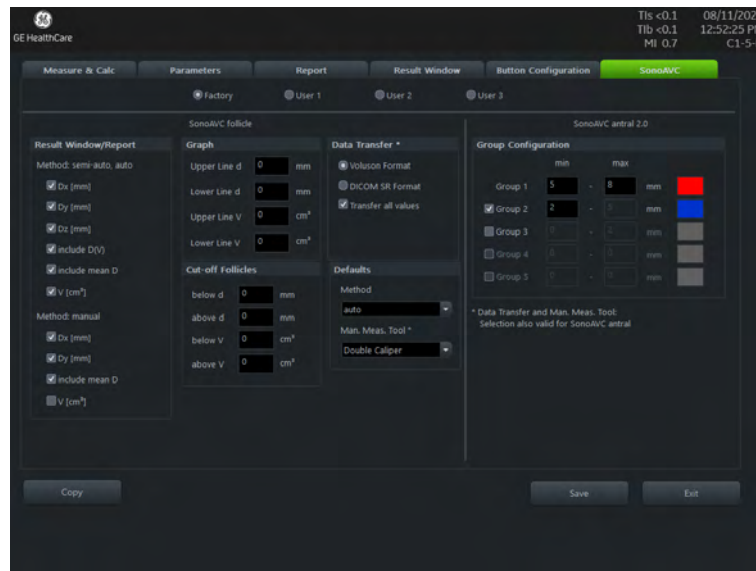

Figure 11-32 SonoAVC™

Controls

Result Columns

Check the parameters, which should be displayed.

Note *If **Save** is pressed and no column is checked, the system automatically checks the column V and a default message appears.*

Graph

Configures the two lines displayed in the graph.

Cut-off Follicles

Enter cut-off values to configure the range of values that are displayed in the result list and graph. All follicles below and above the defined values are displayed in white color in the SonoAVC™ list. They are not displayed in the graph in the worksheet.

Data Transfer

Select the desired format:

- Voluson Format (Default)
- DICOM SR Format
- Transfer all values (Default: On; Transfers all follicles)

Defaults

Select the desired:

- Method: **Auto** (Default), **Semi-Auto**, **Manual**
- Man. Meas. Tool: **2Dist.**(Default), **Ellipse**

Copy

Copies settings from **Factory** to **User**.

Group Configuration

- Select the desired group.
- Enter the group range values (min, max)
- Select the group color configuration

Default settings: Group 1 (5-8 mm, color red), Group 2 (2-5 mm, color blue)

Save

Saves all the changes.

Exit

Press **Exit** to leave the menu.

11.1.10 Quick Setup

The **Quick Setup** contains the most used settings in a guided workflow. The settings are the same as in the “normal” setup and described in the depending chapters.

Enter the **Quick Setup** via the **Home** menu and edit the settings as desired. Press **Next / Back** to switch between the pages and **Save & Exit** to save the changes and close the **Quick Setup**.

Following tabs are available:

- **Exam:** Select applications shown when entering patient exam data.
- **Network:** Configure network preferences and enter email.
- **Buttons:** Select programmable key actions based on data management and workflow preferences.
- **Annotations:** Configure general settings related to annotations, cursor positions and bodymarkers.

This page was intentionally left blank.

Chapter 12

Peripheral Devices

How to Connect Auxiliary Devices Safely ----- 12-2
Peripherals and Hardware ----- 12-5
Connection between Internal I/O and External I/O ----- 12-8
USB Recorder (DVR) - Optional ----- 12-11
ECG Preamplifier ----- 12-14
Gel Warmer ----- 12-17
Battery Pack ----- 12-18
Vscan Air™ (Option) ----- 12-23

12.1 How to Connect Auxiliary Devices Safely

Peripherals, that have been ordered simultaneously with the Voluson™ Signature 18 / Voluson™ Signature 20 system, are usually already mounted and connected. The first mounting and connecting will usually be performed by a GE HealthCare system technician.

How to connect peripheral devices:

1. Ensure that the console is switched off.
2. Connect the peripheral device to the console.
3. Switch the peripheral device on by pressing the Power ON button.
4. Switch on the circuit breaker of the console and press the **standby** button.
5. The connected peripheral device will be supplied with power.

Note *Always observe the instructions given in the manual of the peripheral/auxiliary device.*

Basic Concept:

The Voluson™ Signature 18 / Voluson™ Signature 20 system is equipped with an isolation transformer to provide the required separation from AC Mains for the ultrasound console.

The Voluson™ Signature 18 / Voluson™ Signature 20 system provides several inputs and outputs (I/O) such as Audio, Video, Ethernet, USB, DICOM and Printer signals. Special care must be taken when connecting auxiliary devices via these input and output (I/O) connections.

Note *The Ethernet LAN input and output (I/O) connector is provided with a built-in galvanic isolation according to IEC 60601 (i.e. 1500 V AC). All other input and output (I/O) connections do not provide a built-in galvanic isolation (USB, DVI, HDMI, VGA, S-Video, ...).*

The IEC 60601 standard provides a guideline for safely interconnecting medical devices in systems.

Everybody who connects additional equipment to the signal input portion or signal output portion configures a medical system, and is therefore responsible that the system complies with the requirements of the system standard IEC 60601. If in doubt, consult the technical service department or your local representative.

1. The medical device may be connected to a single IEC (e.g. IEC 60601-1, IEC 60950-1, ...) device (protection class I) placed in a room which is not medically used.
2. If the device is to be connected in a medically-used room the following rule applies:
 - IEC (e.g. IEC 60950-1, ...) compliant devices (protection class I) may be connected with an additional safety measure.
 - IEC 60601 compliant devices may be connected as such.

For all situations 1 and 2, the additional device shall be installed outside the typical patient environment.

Possible additional safety measures are:

Additional protective earth connection between the 2 devices, or a safety isolation mains transformer for the other device.

Special care has to be taken, if the device is connected to a computer network (e.g., Ethernet), because other devices could be connected without any control. There could be an electrical potential difference between the protective earth and any line of the computer network including the shield.

In this case the only way to operate the system safely is to use an isolated signal link with minimum air clearance and creepage distance of the isolation device in agreement with IEC60601 incl. national deviations. For computer networks there are media converters available which convert the electrical to optical signals. Please consider that this converter has to comply with the relevant applicable standards (e.g. IEC 60601-1, IEC 60950-1, ...) and is battery operated or powered by a medical grade power supply (IEC60601-1) or USB powered by connecting to an available USB socket on the Voluson™ Signature 18 / Voluson™ Signature 20 system.

Additionally the IEC 60601 requires control measurement of leakage currents.

Everybody who mechanically attaches or places additional equipment or items onto the medical device configures a medical system, and is therefore responsible that the system complies with the requirements of the system standard IEC 60601. If in doubt, consult the technical service department or your local representative.

The system integrator (any person mechanically attaching other devices; or electrically connecting the medical device to other devices) is responsible that the connections are safe.

12.1.1 Precautions when using peripherals and network connection



Caution

Possible loss of data during transfer via network from the ultrasound system.

Caution

Please observe that some printers may not be medical devices! If the Wireless Printer, Line Printers and / or External monitor are no medical devices, they have to be located outside of the patient environment. Examples for typical patient environments can be found in IEC 60601 (see illustrations below).

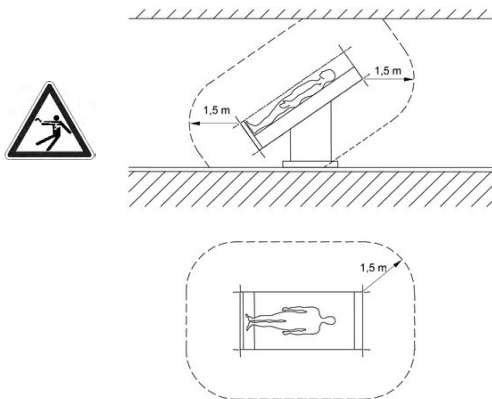

Caution



- Auxiliary equipment with direct AC Mains connection requires galvanic separation of the signal and / or control leads.
- The leakage current of the entire system including any / all auxiliary equipment must not exceed the limit values as per IEC 60601 resp. other valid national or international standards. All equipment must comply with relevant UL, CSA and IEC requirements. All equipment must comply with UL, CSA, IEC or other relevant (national/ regional) requirements.

Caution



- There is an increased risk of electric shock due to increased leakage current when peripherals such as a patient monitor, are connected to AC Mains directly via a AC Mains wall outlet.
- There is an increased risk of electric shock due to increased leakage current when connecting devices not explicitly recognized by the system manufacturer GE ULTRASOUND KOREA, LTD. to the ultrasound system.
- Only use cables delivered with the system or the accessories.
- Only use equipment provided by the system manufacturer GE ULTRASOUND KOREA, LTD..

Caution



For all instructions in the "Electrical Safety Tests" section in case of using UPS (Uninterruptible Power Supply) the terms outlet, wall outlet, AC wall outlet and power outlet refer to the AC power outlet of the UPS. In case of further available AC (or DC) power outlets at the same used UPS, these must remain unused i.e. not connected to any other devices.

Please observe that some printers may not be medical devices! If the Wireless Printer and / or Line Printers are no medical devices, they have to be located outside of the patient environment. Examples for typical patient environments can be found in standard IEC 60601 (see illustrations below).

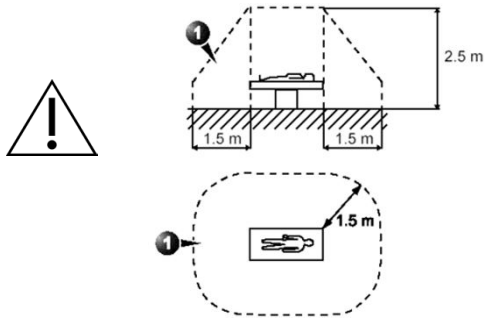

1. Patient environment



Be aware that accessory is not allowed to use other than specified purpose and guidance.



Do not use a combination of UPS and EMI filer.

Note

Isolation Transformer is only for external monitor & commercial printers

12.1.2 Remove USB Devices

There are two ways to remove USB devices;

- Press "Eject Media" on the left column of the menu screen.
 - Stop the USB device in the system setup following the steps below, before safely removing it.
-



USB devices must be stopped before they are unplugged!

1. Go to **Menu - System Setup - Connectivity - Drives** to enter the "Connect USB and Network Drives" dialog.
2. Select the device you want to unplug by using trackball and trackball keys.
3. Press **Stop Device**. A dialog appears asking for confirmation.
4. Confirm with **OK**. The USB stick can be removed safely.
5. Press **Exit** to return to the previous operating state.

12.2 Peripherals and Hardware

Note

Some peripheral devices may not be listed or may not be available in all markets. Please contact your local sales representative for further information.

- WLAN
- Wireless display
- Footswitch
- B&W Medical Grade Printer
- Color Printer
- Network Printer
- Isolation Transformer
- Isolated USB Connector
- EMI Filter
- External ECG USB module
- ECG cable
- Barcode-Scanner
- Card Reader ⁵
- 32" External Patient Monitor
- UPS
- Ethernet protection cable
- Digital Expert
- Integrated UVC
- Gel warmer
- CWD option kit
- Optional horizontal TV holder
- Vertical probe holder insert
- Horizontal probe holder insert
- Optional storage
- Optional power cable management/ hook
- Vscan Air Charger
- Battery pack
- Bluetooth dongle
- SSD
- OPIO rear tray
- Drawer
- Wireless kit for color printer

⁵ For Japan

- Cleaning cloth

List of all cables and maximum length of cables

No	Type	Cable Construction / Manufacturer	Max. Length (m)	Type of Cable
1	AC cable	H05VV-F 3G1.0mm ² Manufactured by VOLEX/FELLER	4	Non-Shielded
2	AC cable	RVV 3G1.0mm ² Manufactured by VOLEX/FELLER	4	Non-Shielded
3	AC cable	VCTF 3G2.00mm ² Manufactured by VOLEX/FELLER	4	Non-Shielded
4	AC cable	SJT 3/14AWG Manufactured by VOLEX/ FELLER	4	Non-Shielded

Table 12-1 Main Power Cable

No	Type	Parts No. / Manufacturer	Max. Length (m)	Type of Cable
1	ECG cable	C3-C-U-ODU-## /C3-C-E-ODU-## Manufactured by NORAV	3.5	Shielded
2	Vscan Air charger cable	NA Manufactured by SJ ELECOM CO LTD	0.15	Shielded

Table 12-2 External Interface Cable (Patient Cable without Probes)

Type	Model name	Max. Length (m)	Type of Cable	Remark
Convex array probe	C1-5-D Manufactured by GE HealthCare	2.2	Shielded	
	C1-6-D Manufactured by GE HealthCare	2.2	Shielded	
	C2-9-D Manufactured by GE HealthCare	2.2	Shielded	
	IC5-9-D Manufactured by GE HealthCare	2.0	Shielded	
Linear array probe	9L-D Manufactured by GE HealthCare	1.95	Shielded	
	11L-D Manufactured by GE HealthCare	1.95	Shielded	
	ML6-15-D Manufactured by GE HealthCare	2.25	Shielded	
Sector phased array probe	M5Sc-D Manufactured by GE HealthCare	2.2	Shielded	
Volume convex array probe	RIC5-9-D Manufactured by GE HealthCare	2.5	Shielded	
	RAB6-D Manufactured by GE HealthCare	2.1	Shielded	

Table 12-3 Maximum length of cables for probes

Digital Expert

Digital Expert Remote Training

Digital Expert is a purchasable option which enables remote training between users and the GE HealthCare Clinical Applications team, through scheduled and real-time sessions. Digital Expert is a self-contained, app-based companion solution, designed to pair with GE HealthCare medical devices. Digital Expert utilized intelehealth software for remote connectivity.

Note *This tool is not for clinical diagnostics purposes.*

Digital expert also enables customer to customer Enterprise Collaboration, where users can connect with each other within their own network. This provides on-demand access for guidance and consultation for clinicians from in-house experts.

12.3 Connection between Internal I/O and External I/O

Power Supply (rear side) -----	12-8
Power Supply (for auxiliary equipment) -----	12-8
Connector Panels -----	12-8

12.3.1 Power Supply (rear side)

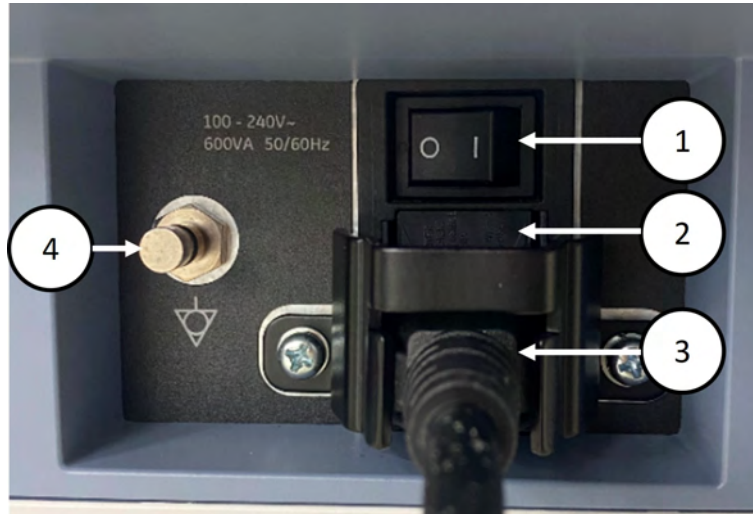

1. circuit breaker
2. fuses (2x 10AL, 250VAC)
3. Mains power cable
4. Equipotential pin

Range of AC Mains Voltages: 100 - 240V~

12.3.2 Power Supply (for auxiliary equipment)

There is one connector for the B/W printer supplying 12V DC.

12.3.3 Connector Panels

For more information see 'External Inputs and Outputs' on page 13-40.

Rear Panel

The rear panel can be found on the rear side of the body of the system.

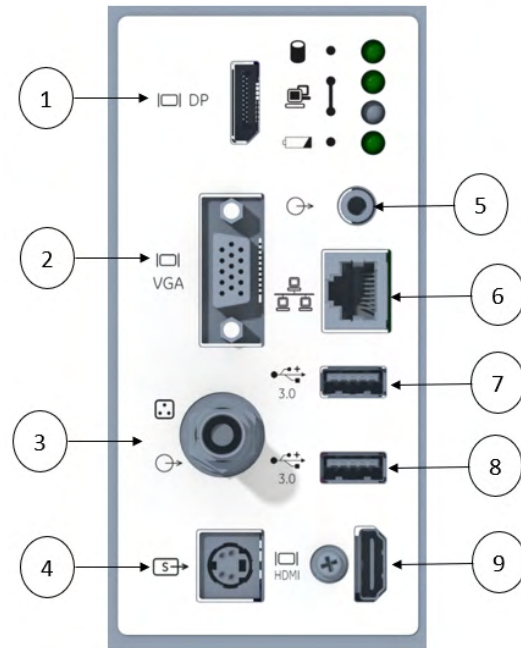

Figure 12-1 The rear panel

Item	Connector Name	Description
1	Display port	DP output for external monitor (Option)
2	VGA	VGA output for external monitor (Option)
3	Composite	Composite output for external monitor (Option)
4	S-Video	S-Video output for external monitor (Option)
5	Line out	Audio output
6	LAN	Ethernet Input
7	USB-A	USB 3.0 port
8	USB-A	USB 3.0 port
9	HDMI	Connector for external monitor

Table 12-4 External I/O connectors- Rear Panel

Connectors for optional peripheral devices

External I/O connectors - back and left/right side of the Console



Figure 12-2 External I/O connectors

Item	Connector Name	Description
1	USB-A	USB 3.0 port intended for optional peripheral devices
2	USB-C	USB 3.0 port intended for optional peripheral devices

Table 12-5 External I/O connectors

12.4 USB Recorder (DVR) - Optional

It is possible to record US data on USB. The external USB-Port has to be activated to play and record from / to a USB-device. Videos are created in .mp4 or .mpg file format. The file name is created automatically by the system and includes the date and time of the recording (i.e.: dvr_YYYYMMDD_HHMM.mp4/.mpg).

If USB devices are available, always the last used media is used for new recording.



Do not disconnect an external USB- device without stopping it. Disconnecting without stopping can lead to data loss on the external device.

Note *After recording to USB it is recommended to check that the file was recorded properly (e. g. try to play recorded data). Sometimes the USB stick media may be defective.*

Note *It is recommended to reboot the system daily. The media quality degrades over time.*

DVR Menu

To open the DVR menu press . A P-button can be configured in the System Setup for Recorder Control.

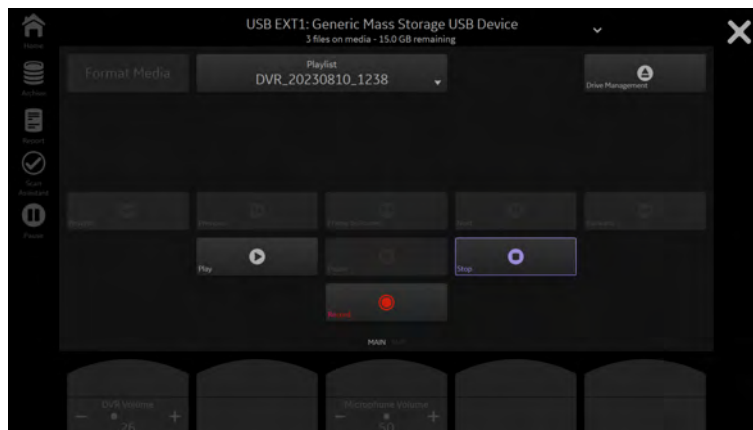

Figure 12-3 DVR/USB Touch Menu (example)

Header Menu	Opens a list of available media (Connected USB storages).
Format	Formats the media and then ejects it.
Play List	Opens a popup displaying all tracks.
Eject	Safely removes USB hardware.
Next	Goes to the next title.
Previous	Goes to the previous title.
Rewind	Searches reverse way.
Forward	Searches forward way.
Frame by Frame	Press Play and Pause and then Frame by Frame to go to the next frame.
Play	Starts playback.
Pause	Pauses playing.
Stop	Stops and displays the image on screen.
Record	Record Mode.

DVR Volume	Adjusts the play volume (only at play mode).
Microphone Vol	Adjusts the recording volume of the microphone (0-100%).







Messages

A progress bar and different messages can appear. Possible messages are:

- DVR: recorder busy
- DVR: formatting
- disc full
- no space left on USB device
- if the file check of a recorded file detects an error: An error occurred while recording.

DVR Icons

Depending on the USB mode different icons can be displayed:

	USB available, disc inserted.
	USB PLAY mode.
	USB PLAY-PAUSE mode.
	USB REC mode.
	USB REC-PAUSE mode.
	USB status: busy.



The full info display contains the number of titles and the remaining space on the disc.

Following media is supported:

1. USB:
 - USB stick
 - HDD-FAT32 or NTFS file system

Microphone

It is possible to record external sound with a microphone. When a microphone is connected and activated in the System Setup, following icons are displayed for voice recording:

	The microphone is On .
	The microphone is recording.
	The microphone is muted.

Note *No internal sound can be recorded when the microphone is **On**.*

Video recording on a USB stick

1. Connect a USB stick.

2. Press .
3. Select **USB** on the touch panel.
4. To start and stop recording press the programmed P-button or use the according DVR Menu controls.
5. To eject the USB press **Eject** on the touch panel.

Note

A minimum writing speed of 2 MByte / sec is required to ensure stable video recording on USB devices. Lower writing speed can result in audio and / or video drop-outs.

The use of USB3.0 devices is recommended.

12.5 ECG Preampifier

Note *This feature may not be available at the time of release of these Instructions for Use.*

The ECG preampifier is an option of the ultrasound scanner system used to obtain an ECG signal to mark the systolic and end diastolic moments in M mode and Doppler evaluations.



- The ECG preampifier is not intended for ECG diagnosis. It must not be used for an intra-operative procedure of the heart.
 - Monitor: Not for use as a cardiac monitor.
 - Only the patient cable supplied by GE ULTRASOUND KOREA, LTD., and only recommended electrodes must be used.
 - Take care that neither bare parts of one of the three electrodes nor the patient comes into contact with conductive parts (e.g., metal parts of the examination bed, trolley, or similar).
 - If the use of a HF surgical system with simultaneously connected ECG electrodes becomes necessary, a large distance of ECG electrodes from the surgical field and a perfect position of the neutral electrode of the HF surgical system must be observed (avoiding burning risk).
 - If the use of a defibrillator becomes necessary, there must be no ECG adhesive electrodes and no conductive paste between the correct positions of the defibrillator plates (avoid current bridge; the signal input of the ECG preampifier is defibrillator-safe).
-
- The ECG Module (NORAV ECGUSB1D-EX) consists of an ECG preampifier (a small system-external ECG-Box), a patient connection cable and USB cables.
 - For defibrillation situation, Patient connection cable **MUST BE USED** with the 'NORAV, code C3-C-E-ODU## and C3-C-U-ODU-##' only.
 - The 3 ECG electrodes, which can be clipped to the patient connection cable, act as the applied parts, which are in electrical contact with the patient, classified as CF applied part.
 - The ECG preampifier is used for acquiring an ECG signal to be displayed with the ultrasound image. The ECG preampifier must not be used for ECG diagnostics. It is not intended for use as a cardiac monitor.
 - The ECG preampifier can be connected to any user accessible USB C type connector on the Voluson™ Signature 18 / Voluson™ Signature 20 system, for example USB-C socket on Left/ Right side of OPIO, as displayed in this picture:

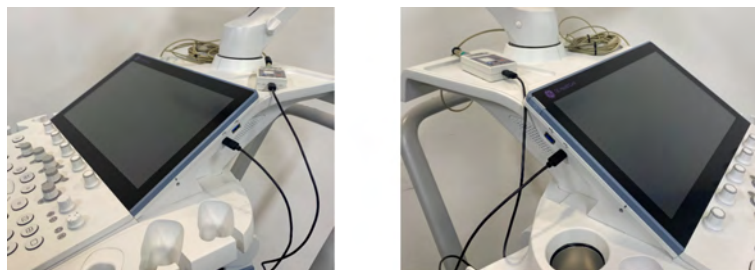

Figure 12-4 Connecting the ECG preampifier to user accessible USB-C socket

Note *For more information see 'ECG preampifier' on page 13-41.*

12.5.1 Information for safe use of ECG

- The simultaneous use of stimulation current devices can influence the ECG signal.
- If several instruments are simultaneously used on the patient, all instruments must be connected to an appropriate potential equilibrium (avoidance of lead currents).
- The ECG provided for use with this system is defibrillation-proof.

- When using a defibrillator while having the ECG connected, also always refer to the defibrillator's Instructions for Use.

12.5.2 Handling

Press **Home** and select ECG. The ECG menu appears on the touch panel.

- Position, speed and amplitude of the displayed ECG strip can be altered in the ECG menu on the touch panel of the ultrasound machine.
 - The patient cable shall always be connected to the ECG preamplifier.
 - With the patient cable belonging to the ECG preamplifier only electrodes for push-button connection can be used. Depending on requirements, commercially available extremity clamp electrodes together with conductive gel or commercially available pre-jelled adhesive electrodes can be used, preferably the latter should be used.
 - With standard setting of the electrodes (red = right arm, yellow = left arm, black = left leg) lead I is displayed. Other electrode arrangements may be necessary (lead II, III), if amplitude supplied by lead I is too small.
1. Adjust the transmission gain of the ECG preamplifier signal (0, 1, 2, 3).
 2. Select ECG velocity (0, 1, 2, 3).
 3. Set the vertical position on the monitor.
 4. Adjust ECG amplitude (0 to 100 in 10 steps).
 5. Return to the main menu. The ECG function remains active.
 6. Freeze the image. The most recent information is always on the right edge of the image.

When moving the trackball, an indicator (small vertical line) gets inserted on the ECG curve and indicates the temporal position of the 2D image in relation to the recorded ECG line. In this manner e.g., diastolic or systolic phase of the 2D mode image can be set (without ECG trigger).



Remarks:

- Touch **Off** key to switch off the ECG Display function. Touch **On** key to switch on the ECG Display function.
- On the screen the ECG curve starts running from left to right if scan mode is active.
- The most recent information is always on the right edge of the image.
- ECG speed adjustment is only possible in scan mode.

12.5.3 ECG Cine

ECG 2D Cine

In the ECG memory a longer period than the one displayed on the monitor is stored. With the help of the trackball key **Cine** the previous ECG curve can be scrolled.

ECG Cine-Split Function

1. Use **Format** to change to the next (part of) frozen image sequence to play back the ECG Cine memory.
2. Adjust the first trigger image with the trackball.
3. Switch the image position (press key again) and adjust the second trigger image with the trackball.

Remark:

- The green ECG line indicates to which image the trigger mark is related.

12.5.4 Safety Rules to be followed

- The ECG preamplifier is an integral part of the ultrasound scanner unit. The system may only be operated in places that go conform with the rules for medically used locations.
- The power cable of the ultrasound scanner system must not be connected to a damaged socket. The socket must be equipped with a grounded conductor. If necessary a potential equilibrium must be connected.
- Only the patient cable provided by GE ULTRASOUND KOREA, LTD. may be used. Consequently, only push-button electrodes may be used.
- Take care that neither bare parts of one of the electrodes nor the patient can get in contact with conductive parts (e.g., metal parts of the examination bed, trolley, or similar).
- This device must not be used for an intra-operative procedure on the heart.
- If the use of a HF surgical system with simultaneously connected ECG electrodes becomes necessary, a large distance of ECG-electrodes from the surgical field and a perfect position of the neutral electrode of the HF surgical system must be observed (avoiding burning risk).
- Note that stimulation current devices can influence the ECG signal.
- If several instruments are simultaneously used on the patient, all these instruments must be connected to an appropriate potential equilibrium (avoidance of lead currents).
- If the use of a defibrillator becomes necessary, there must be no ECG adhesive electrodes and no conductive paste between the contact positions of the defibrillator plates (avoidance of current bridges; the signal input of the ECG preamplifier is defibrillator-safe).
- When used with the appropriate ECG cable, the ECG is protected against the effects of cardiac defibrillator discharge.
- Conductive parts of electrodes and associated connectors for applied parts including the neutral electrode should not contact other conductive parts and earth.

Note *Follow the Instructions for Use of the defibrillator. Do not touch the patient during defibrillation.*

12.5.5 Care and Maintenance, Repairs

- Electrodes and the cables should be handled with the usual care. Refer to manufacturer's instructions in concerns of cleaning and maintenance.
- Refer to manufacturer's instructions concerning cleaning, disinfection and sterilization.
- The ECG preamplifier does not require special maintenance but should be handled with care.
- Do not perform any changes or repairs on the ECG preamplifier, the connecting cables or the patient cable. A damaged patient cable must be replaced.
- Necessary repairs must be performed by authorized service personnel only!

12.6 Gel Warmer



Figure 12-5 Gel Warmer

Switch the gel warmer on by moving the switch to **I**. The gel warmer warms up the scanning gel. Switch it off by moving the switch to **O** position.

Note *The gel warmer works even in standby mode. But it isn't work without AC power (battery standby mode).*

Electrical rating: 12Vd.c., 13.2VA

12.7 Battery Pack

With Battery Pack, the system power is maintained by the battery when there is an AC power failure or the power cable is unplugged. Also, the one helps to maintain the system power when it needs to be moved to other place. This can be used to reduce system startup time for portable exams.

- **Battery Mode**

When in Battery Power Mode, the system maintains the current patient and can scan or perform other operation normally.

Note *Only GE Service personnel have access to the battery. Please contact the technical service department or your local GE Healthcare representative for replacement. Also, replace all battery packs at the same time to avoid confusing used and new battery packs.*

Note *Under battery pack, the external printers are not able to be used.*

Note *When the system detects battery deterioration, it displays a message. If the message displays, contact the technical service department or your local GE Healthcare representative.*



When in Battery Power Mode and remaining battery capacity is 15% or less, the system shows a “Battery Power Mode: Low battery capacity” message. And If the remaining battery capacity is 15% or less, the system will automatically start the full shutdown sequence after a few minutes.





Verify battery functionality is available by the battery icon in top-right corner of the menu. It is imperative to confirm the battery icon indicator before unplugging power cord from wall power. Full charging condition is recommended for Battery Power Mode. Unplugging system from wall power with <15% battery could result in a sooner than expected shutdown warning.

12.7.1 Battery Status View

When the system is running on battery power, the following icons display on the status area at the right-bottom.

Icon	Capacity: N/A
	<ul style="list-style-type: none"> • ICON: No Icon • STATE: No battery Present
	<ul style="list-style-type: none"> • ICON: Battery Warning • STATE: battery exist or not • CAPACITY: N/A
	<ul style="list-style-type: none"> • ICON: Power Mode • STATE: AC power Plugged • CAPACITY: N/A
	<ul style="list-style-type: none"> • ICON: Battery Mode • STATE: AC power Unplugged • CAPACITY: 76%~100%
	<ul style="list-style-type: none"> • ICON: Battery Mode • STATE: AC power Unplugged • CAPACITY: 51%~75%

Icon	Capacity: N/A
	<ul style="list-style-type: none"> • ICON: Battery Mode • STATE: AC power Unplugged • CAPACITY: 21%~50%
	<ul style="list-style-type: none"> • ICON: Battery Mode • STATE: AC power Unplugged • CAPACITY: 16%~20%
	<ul style="list-style-type: none"> • ICON: Battery Mode • STATE: AC power Unplugged • CAPACITY: 1%~15%

12.7.2 Battery Tooltip

When mouse point moves on battery icon, tooltip displays battery information including battery power source, and battery capacity.

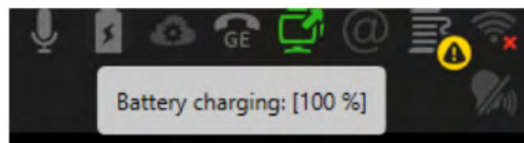

Figure 12-6 Power Mode

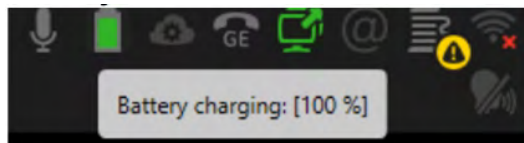

Figure 12-7 Battery Mode

12.7.3 Battery message and alert

Temperature Warning & Shutdown Message

The system shall notify warning message to user when battery temperature is high. The system shall shutdown when temperature is over temperature limitation.

- **[Temperature Warning limitation]:** Over 70°C
- **[Temperature Shutdown limitation]:** Over 75°C

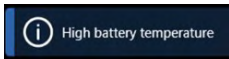
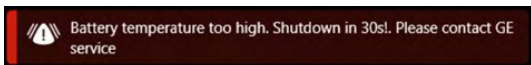
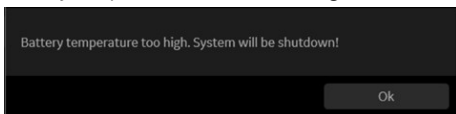
Battery temperature warning message	
Battery temperature shutdown message	
Battery temperature shutdown dialog	

Capacity Warning & Shutdown Message

The system shall notify warning message to user when battery capacity is between 50% and 16%. The system beeps twice when the battery level drops to 20%.

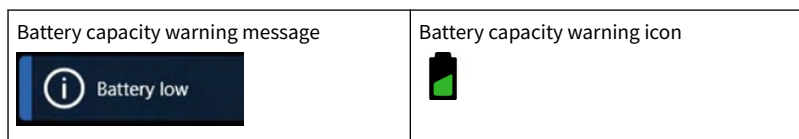

The system shall notify warning message to user when battery capacity is between 50% and 16%. The system beeps twice when the battery level drops to 20%.



The system shall shutdown when battery capacity is lower than 5%.



Battery Replacement Notification

When the overall capacity of the cell is less than 50%, 40% and 33% of the expected capacity of the cell at production, the system notifies the battery life to user.

<p>>/=50%: "Normal"</p>	<p>Normal: Your battery is working within normal parameters.</p>
<p>40%: "Low"</p>	<p>Replace Now: Your battery is still working, but its health has significantly degraded. Please contact your GEHC service technician to replace the battery soon.</p>
<p>33%: "Replacement required"</p>	<p>Service Battery: Your battery is no longer functioning with enough capacity to support your system and must be replaced. Please contact your GEHC service technician to replace the battery as soon as possible.</p>

12.7.4 Battery Mode

When in Battery Power Mode, the system maintains the current patient and can scan or perform other operation normally.



12.7.4.1 Starting Battery Mode

When the AC cable is unplugged or if there is an AC power failure, the system works with Battery Power Mode. The system maintains the current operations and can scan or perform other operations normally.

Note *The following message "Battery Mode" appears on the display when mode change from Power Mode to Battery Mode or when program initialized.*

Note *Approximate discharging time from full to empty (depend on the battery's state of health).*

- 3 battery packs: About 1h 15m
- 6 battery packs: About 2h 30m

Battery Mode - Notification Message	
Battery mode message	Battery mode icon
	

12.7.4.2 Starting Power Mode

Note The Following message "Power Mode" appears on the display when mode change from Battery Mode to Power Mode or when program initialized.

Note Whether the system is on or off, the battery will charge as long as the system is connected to AC power via the power cable, and the circuit break is on. While the battery is charging, the back battery LED will blink. When the battery is fully charged, the LED will stop blinking and remain on.

Note Approximate charging time from empty to full.

- 3 battery packs: About 1h 40m
- 6 battery packs: About 3h 20m



Power Mode - Notification Message	
Power mode message	Power mode icon
	



Figure 12-8 LED location of the battery

12.7.5 Recovering System

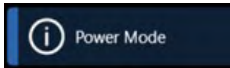
In case of Battery Mode, the system does not display a "Battery Mode" message any more when the system power is recovered.

12.7.6 Boot up the system on battery

The system can be turned on without AC power. With the AC cable disconnected, press and hold the power button for more than 5 ~ 10 seconds to turn on the system.

Note If the remaining capacity of the battery is less than 30%, the system can't be turned on.

Note If you try to boot by the battery after turning off the system while using the battery (Charge/discharge), a waiting time of about 20 seconds is required. After that, you can do battery booting.

12.7.7 Refresh the battery

To maintain the battery life, it is recommended to refresh the battery according to the "Battery Replacement Notification".

Refresh procedure:

- Turn on the system
- Wait until the battery is fully charged. It takes at least 1 hour 40 minutes (For 3 battery packs) / 3 hour 20 minutes (For 6 battery packs) to fully charge the battery (Depend on the remaining battery capacity).
- Turn off the system
- Remove all probes
- Turn on the system
- Unplug the AC cable and wait until the system shuts down
- Wait at least 5 hours
- Plug in the AC cable
- Turn on the system
- Wait until the battery is fully charged

12.7.8 Battery Disposal

Lithium Ion Used batteries must be disposed of properly and as chemical waste. They cannot be treated as regular waste. Contact your building administration for proper disposal.

Note *When removing a defective battery, ensure that it is disposed of in accordance with local regulations. Alternatively, provide it to GE HealthCare for proper disposal.*

12.8 Vscan Air™ (Option)

The Vscan Air™ is a battery-operated, wireless, general-purpose diagnostic handheld ultrasound imaging system, first released by GE HealthCare in 2020. Vscan Air consists of a dual-headed curved and linear probe (Vscan Air CL), and a mobile app. (See) The Vscan Air CL probe acquires and forms the ultrasound image, while the Vscan Air mobile app contains the software needed to use a mobile device as the display and the user interface control unit.

More information about the Vscan Air CL probe, care and handling, and use with the mobile app, can be found in the Vscan Air™ User Manual on the GE HealthCare Customer Documentation Portal website at:

<https://www.gehealthcare.com/support/manuals>

To access the Vscan Air™ User Manual at the above link, in the "Search By" field on the webpage, enter "GP092020-1" and select the "Search" button. All language versions of the manual will be listed and available to view or download.

The Vscan Air CL acquires and forms the ultrasound image, sends the image data in real time through Wi-Fi to the ultrasound system, and the console displays the image. The ultrasound system provides the needed software to use the console as the display and the UI control unit (see)

The Vscan Air CL probe supports black/white (B-Mode), Color Flow (Color Doppler), combined (B plus Color Doppler) modes with both the curved and linear array probes.

With the curved probe on Vscan Air CL, the specific clinical applications and exam types include: Abdominal, Fetal/OB, Gynecological, Urology, Thoracic/Lung, Cardiac (Adult and Pediatric, 40 kg and above), Vascular/Peripheral Vascular, Musculoskeletal (Conventional), Pediatrics and Interventional Guidance (includes free hand needle/catheter placement, fluid drainage, nerve block and biopsy).

The linear probe on Vscan Air CL clinical applications and exam types include: Vascular/Peripheral Vascular, Musculoskeletal (Conventional and Superficial), Small Organs, Thoracic/Lung, Ophthalmic, Pediatrics, Neonatal Cephalic and Interventional Guidance (includes free hand needle/catheter placement, fluid drainage, nerve block, vascular access and biopsy).

The supported imaging modes and supported clinical applications on Vscan Air CL with the ultrasound system is consistent with those on Vscan Air™ with the mobile app.

12.8.1 Prepare Vscan Air Probe for Use



Caution

Only use GE HealthCare provided chargers or a Qi compliant charger with the Vscan Air probe. Failure to use a compliant charger may result in the probe not charging, or possible damage to the probe.



Caution

Scanning stops within 10 seconds if the Wi-Fi link to the VscanAir probe is lost. Ensure Wi-Fi connection is sufficient to avoid loss of image and delay of care.



Caution

The probe will not begin a scan if the VscanAir probe battery is critically low. Ensure probe is sufficiently charged before beginning scan to avoid delay of care.



Caution

Scanning stops within 10 seconds when the Vscan Air probe battery becomes critically low. Ensure probe is sufficiently charged before beginning scan to avoid delay of care.

Caution

The following information provided in the User Manual of the Vscan Air product is not valid (see Chapter1 Introduction):

- Intended use / Indications for use
- Clinical benefit
- Contraindications for use
- Intended users
- General description (intended Patient population)



Instead, this information is to be consulted for in the Instructions for Use of the ultrasound console Voluson™ Signature 18 / Voluson™ Signature 20 system (see 'Information for safe use' on page 2-11) :

- Intended use
- Clinical benefit
- Contraindications
- Operator profile
- Patient population

Caution



The ultrasound console Voluson™ Signature 18 / Voluson™ Signature 20 system with the Vscan Air ultrasound probe is not intended for ophthalmic use or any use causing the acoustic beam to pass through the eye.

Caution



The ultrasound console Voluson™ Signature 18 / Voluson™ Signature 20 system with the Vscan Air ultrasound probe is not intended for lung use.

- Note** *In general, the User Manual of the Vscan Air product remains valid except for sections where specific applications are described which are not supported when the Vscan Air ultrasound probe is used with the ultrasound console Voluson™ Signature 18 / Voluson™ Signature 20 system.*
- Note** *Ensure only one Vscan Air ultrasound probe is in the vicinity of the ultrasound console Voluson™ Signature 18 / Voluson™ Signature 20 system. The ultrasound console Voluson™ Signature 18 / Voluson™ Signature 20 system will try to pair with the Vscan Air ultrasound probe with the strongest signal.*
- Note** *To guarantee the maximum performance with the Vscan Air ultrasound probe on the ultrasound console Voluson™ Signature 18 / Voluson™ Signature 20 system, check the environment and avoid other Wi-Fi devices nearby.*
- Note** *In case the Wi-Fi functionality of the ultrasound console Voluson™ Signature 18 / Voluson™ Signature 20 system is also used as a wireless data network-connection (e.g. hospital-network, internet-connection, etc.) for the operation of the Vscan Air ultrasound probe can lead to delays in communication.*
- Note** *Connect to the network infrastructure through an ethernet cable-connection, if possible, to avoid any possible Wi-Fi interference.*
- Note** *The Vscan Air ultrasound probe must be activated from a mobile (Android, iOS) device first through the Vscan Air app. The ultrasound console Voluson™ Signature 18 / Voluson™ Signature 20 system does not provide a workflow for activating a new Vscan Air ultrasound probe.*

- Note** *The probe check for the Vscan Air ultrasound probe must be performed using the Vscan Air app on a mobile (Android, iOS) device. The ultrasound console Voluson™ Signature 18 / Voluson™ Signature 20 system does not provide this functionality for the Vscan Air ultrasound probe.*
- Note** *The acoustic table declaration of the Vscan Air (which is part of the Vscan Air User Manual) remains valid.*
- Note** *Ensure only one Vscan Air is around the console. The system will try to pair with the Vscan Air with strongest signal.*
- Note** *To guarantee the maximum performance with Vscan Air on the ultrasound system, check the environment and avoid other Wi-Fi devices.*
- Note** *Make sure ultrasound system is connected to an access point (if needed) BEFORE pairing with Vscan Air. Connecting to access point after pairing with Vscan Air will result in significant performance degradation.*
- Note** *Connect to the network infrastructure through an ethernet connection, if possible, to avoid any possible Wi-Fi interference.*
- Note** *Vscan Air must be activated from a mobile (Android, iOS) device first through the Vscan Air app. The ultrasound system does not provide a workflow for activating a new VScan Air.*

12.8.2 Vscan Air Probe Charger



Caution

The Vscan Air probe charger must ONLY be used to charge the Vscan Air probe. DO NOT charge a mobile phone or any other device with the Vscan Air probe charger. Failure to follow these instructions may damage the charger or other device.

FCC Statement

This device complies with Part 15 of the FCC Rules. Operation is subject to the following two conditions: (1) This device may not cause harmful interference, and (2) this device must accept any interference received, including interference that may cause undesired operation.



Warning

Changes or modifications not expressly approved by the party responsible for compliance could void the user's authority to operate the equipment.

- Note** *This equipment has been tested and found to comply with the limits for a Class B digital device, pursuant to Part 15 of the FCC Rules. These limits are designed to provide reasonable protection against harmful interference in a residential installation.*
- This equipment generates, uses, and can radiate radio frequency energy and, if not installed and used in accordance with the instructions, may cause harmful interference to radio communications. However, there is no guarantee that interference will not occur in a particular installation. If this equipment does cause harmful interference to radio or television reception, which can be determined by turning the equipment off and on, the user is encouraged to try to correct the interference by one or more of the following measures: (1) Reorient or relocate the receiving antenna. (2) Increase the separation between the equipment and receiver. (3) Connect the equipment into an outlet on a circuit different from that to which the receiver is connected. (4) Consult the dealer or an experienced radio / TV technician for help.*

Radiation Exposure Statement

This equipment complies with FCC radiation exposure limits set forth for an uncontrolled environment. This equipment should be installed and operated with minimum distance of 20 cm between the radiator & your body.

IC Statement

This device complies with RSS-216 of Industry Canada. Operation is subject to the condition that this device does not cause harmful interference.

This device contains licence-exempt transmitter(s)/receiver(s) that comply with Innovation, Science and Economic Development Canada’s licence-exempt RSS(s). Operation is subject to the following two conditions:

1. This device may not cause interference.
2. Any changes or modifications not expressly approved by the party responsible for compliance could void the user’s authority to operate the equipment.

RF exposure statement: The equipment complies with IC Radiation exposure limit set forth for uncontrolled environment. This equipment should be installed and operated with minimum distance 20cm between the radiator and your body.

Install the Vscan Air Probe Charger

1. Install the Vscan Air probe charger onto the Charger holder.

Note *Be aware of the Vscan Air probe charger and Charger holder direction.*

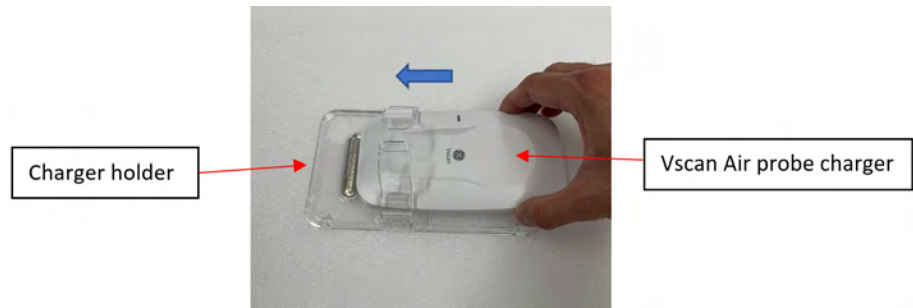

Figure 12-9 Install the probe charger onto the charger holder

2. Put the probe charger assembly onto the top cover left or right of the system. USB C type port of the probe charger shall be facing outside of the system.



Figure 12-10 Install the charger on the left/right side

3. Connect the wireless charger cable L or R.
 - 3.1. Connect the wireless charger cable L when the Vscan Air charger mounted on the left side of the system.

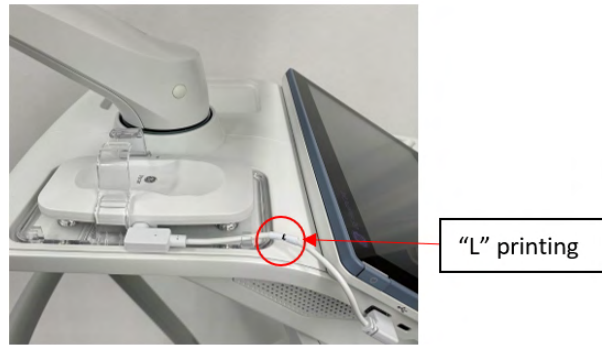

Figure 12-11 Connect the wireless charger cable L on left side (There is 'L' printing on the cable)

- 3.2. Connect the wireless charger cable R when the Vscan Air charger mounted on the right side of the system.

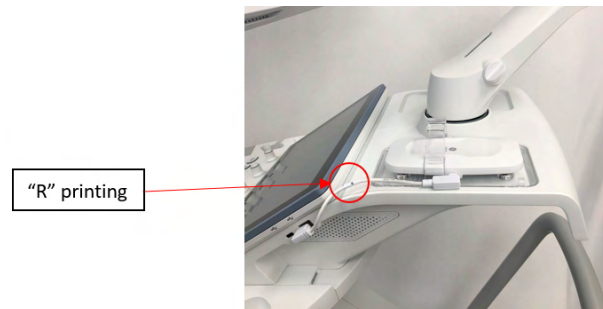

Figure 12-12 Connect the wireless charger cable R on the right side (There is 'R' printing on the cable)

4. Place the Vscan air on the left or right to begin charging.



Figure 12-13 Install the charger on the left side



Figure 12-14 Install the charger on the right side

Charge the Vscan Air Probe

To charge the Vscan Air probe, place the probe inside of the plastic probe holder on the probe charger.

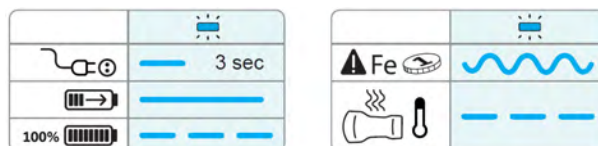

Figure 12-15 Signal Indicator

Caution



1. Do not place any foreign materials, such as metal objects, magnets, and magnetic stripe cards between the Vscan Air™ probe and the charger.
2. Use this charger in an ambient temperature between 0°C ~ 40°C.
3. Do not disassemble the charger.
4. Use original or certified cable and charger for safe charging.
5. Keep a distance of at least 20 cm (7.87 inches) between implanted medical devices (pacemakers, cochlear implants, etc.) and this charger, to avoid potential interference with the medical devices.

12.8.3 Pair Vscan Air Probe to the Ultrasound System

To pair the Vscan Air to the ultrasound system:

1. Turn the ultrasound system on.
2. Press and hold the Vscan Air power button for approximately two seconds, while watching the probe LED lights.

Note Do not continuously hold the button for longer than 5 seconds, or the probe will shut down after booting up.

The LED lights will first briefly display the battery level (green, yellow, or orange), then the display power up (two blue lights). Release the Vscan Air power button when you see the power up light.

3. Access the probe menu and touch the connect button on the touch panel to initiate the pairing process.

Note If the Vscan Air CL probe is not pairing, please ensure that both Bluetooth and Wi-Fi are connected.

4. The LED lights will enter the booting up state (two white lights blinking alternately), followed by the searching state (two white lights blinking synchronously). **Tap** the power button to allow connection during searching state.
5. Pairing will take 5-30 seconds to complete. When pairing is complete, the two LED lights will shine steady blue, indicating the connection is established. At the same time, the Vscan Air CL probe icon will appear on the touch panel, and the probe battery, WiFi icons and temperature status icon will also show on the touch panel.

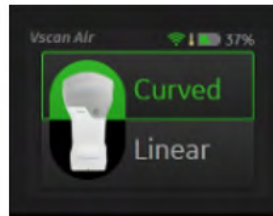

Figure 12-16 Icons of Vscan Air
CL probe, probe battery, WiFi
and temperature

Vscan Air Battery Indicator

Wireless Connection Quality Indicator

A wireless probe has a limited inherent risk of a disrupted connection due to various factors that could lead to loss of real time imaging. The 'Wireless Connection Quality Indicator' provides a visual indication of the connection quality between the probe and the ultrasound system during scanning. The left image indicates a compromised Wi-Fi connection and the image on the right indicates a good Wi-Fi connection. An unstable connection may result in loss of image quality or slow image update during real time imaging.



Figure 12-17 Wi-Fi Connection Quality
Indicator Icons - Left: Compromised,
Right: Good

Vscan Air Temperature Indicator and Thermal Management

When the Vscan Air CL operating temperature is increased, the thermal management system inside the probe may automatically decrease frame rates and/or reduce image width, to keep the probe temperature within optimal functional levels to support continuous scans up to 50 minutes. There are five thermal management levels (0-4). Level 0 is the initial state when starting with a cool probe, and at Level 4 the probe temperature reaches the maximal allowed level. At Level 4 a user notification will appear on screen and the probe will automatically shut down.

The 'Probe temperature indicator' tracks and displays changes in the operating temperature of the probe during scanning. Factors affecting probe temperature are:

- **Transducer:** The curved array transducer gets warm more quickly than linear array due to higher power consumption.
- **Preset:** Certain presets like Abdominal and Cardiac have higher power requirements, depending on the image settings, causing the probe to warm up faster than other presets.
- **Mode:** Operating in Color Flow mode warms up the probe faster than Black and white mode.
- **Length of scan:** The duration of continuous scanning.
- **Ambient temperature:** Higher ambient temperatures can cause the probe to warm faster.

Note *The probe temperature and related user notifications are independent of the probe battery status.*

Scanning

To begin scanning with the Vscan Air:

1. Select the Vscan Air probe icon on the touch panel

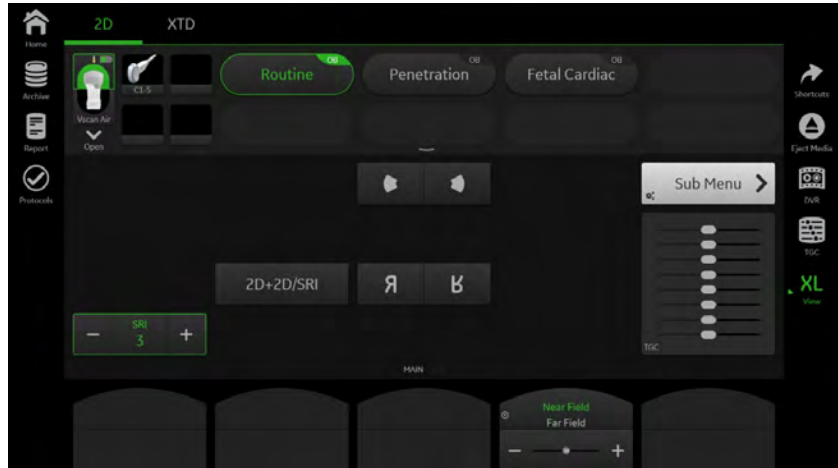

2. Select the Curved or Linear button in the touch panel.

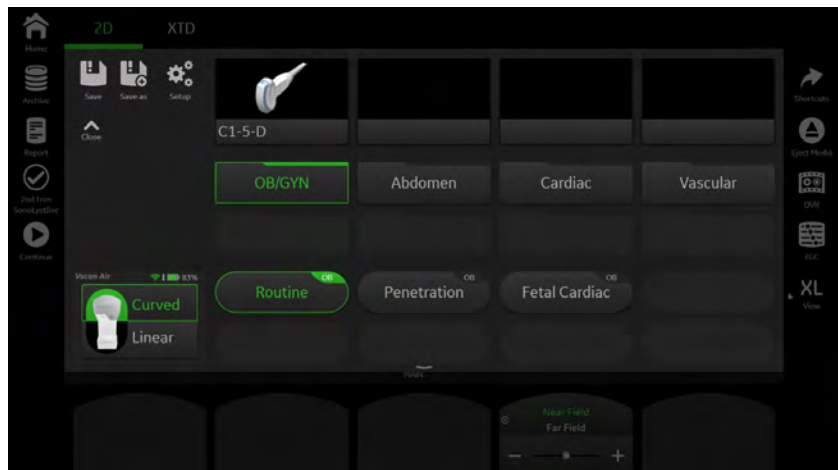

3. Select an application and preset in the touch panel. The Vscan Air probe begins scanning and the system displays the images.

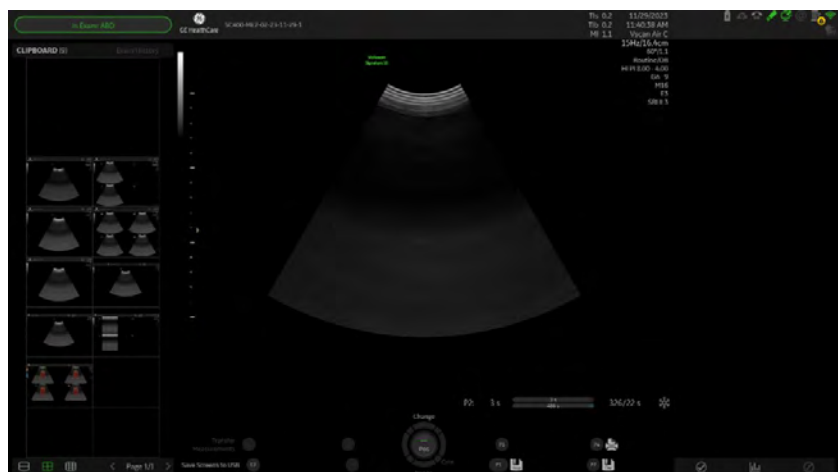

12.8.4 Preparing for a Guided Procedure with Vscan Air

A wireless probe has a limited inherent risk of a disrupted connection due to various factors that could lead to loss of real time imaging.



Warning

If a temporary, unexpected disruption to real time imaging is determined to have a severely negative adverse effect on the patient's health, outweighing the benefits of using an ergonomic wireless probe at the point of care, it is recommended to consider using a wired ultrasound device for the specific procedure guidance.



Caution

When performing a guided procedure or a freehand biopsy (without a biopsy guide), it is the user's responsibility to use the appropriate equipment. Ensure that the needle (especially the needle tip) is always visible in the ultrasound image during the entire procedure.



Caution

Always use only B-Mode when performing guided procedures or a freehand biopsy.

Prepare Vscan Air Probe and Check Wi-Fi Connection Prior to a Procedure

Prior to setting up for a guided procedure, it is recommended to prepare the Vscan Air probe to be in optimal condition, and if assess if a stable WiFi connection can be maintained during the procedure. Follow the below steps for the assessment.

Use a Cool Probe

Ensure the probe is sufficiently cooled down after any previous scanning. Disruption may occur due to the probe getting warm if a lengthy procedure is anticipated. Leaving the probe on a desk (outside the pocket or the case) after it is powered off will cool it down faster. It should take approximately 30-60 minutes to get to a reasonably cool state, depending upon how warm it was from the previous scan, and the ambient temperature. If accelerated cooling of the probe is required, place the probe, while turned off, in front of a fan, run under cold water, or apply a cooling pack.

Ensure the Probe is Sufficiently Charged

Ensure the probe battery is sufficiently charged before beginning a procedure. Battery levels of 50% and above are recommended before starting. The battery level of the probe can be checked on the top left of the imaging screen after connecting with the system. A green battery icon indicates sufficient battery level.

Check Wi-Fi Environment

Whenever possible, check the Wi-Fi connection between the probe and ultrasound system in the environment where the procedure is expected to be performed. This will help detect any unexpected challenges before the actual procedure.

Select Small Parts from the Linear presets menu (Small Parts is the most Wi-Fi-challenging preset due to its high image data rate) and turn up the B-Mode gain. Ensure that the connection quality indicator is steadily green on the touch panel. Observe the noise pattern, and the random movement of noisy pixels should not appear to pause occasionally.

The probe temperature indicator is also visible on the right upper corner of the touch panel. A blue colored thermometer icon confirms a cool probe.

12.8.5 Disconnect Vscan Air Probe

To disconnect the Vscan Air probe from the ultrasound system, simply turn off the probe by pressing and holding the power button until the LED lights appear purple, indicating that the probe is powering down. Alternatively, you can select another probe and preset.

12.8.6 Supported Features

Most features on the ultrasound system (measurement, annotation, image tag, etc.) are supported on the Vscan Air CL probe.

Feature Name
B-Mode
Color Flow
Overwrite and create application presets
Retain FOV
RawData (B-Mode and Color Flow)
Scan Assistant
Measurement Package (by application)
Body Patterns (by application)
Virtual Convex
Imaging Display (Dual/Quad, B/CF Simultaneous)
Print/Recall/Change order
Patient Page/Exam Category

Table 12-6 Features Available on the Vscan Air

12.8.7 Charger Cleaning and Disinfection

For approved charger cleaners and disinfectants, refer to 'Cleaning and disinfecting the system' on page 2-24



Caution

Avoid using ALCOHOL (ISOPROPANOL) 70% on the Vscan Air probe holder and charger. ALCOHOL (ISOPROPANOL) 70% may compromise the durability of the probe holder and charger.



Caution

To prevent cross-contamination, clean and disinfect the Vscan Air probe holder and charger after every exam.

To clean and disinfect the Vscan Air probe holder and charger:

1. Remove the Vscan Air probe from the charger and place in a safe location.
2. Remove the probe charger from the charger holder.

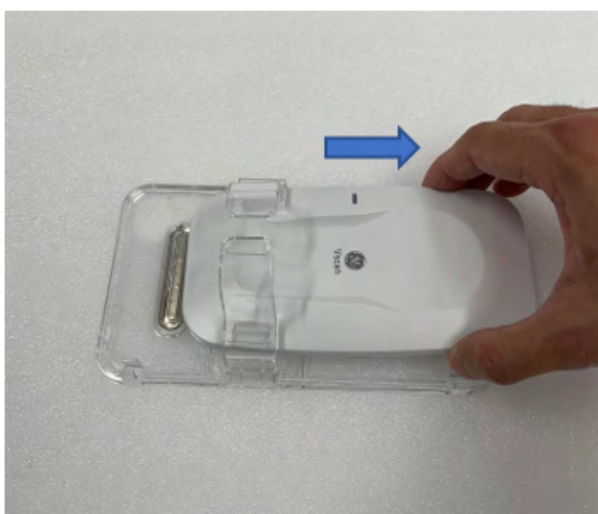

Figure 12-18 Remove the probe charger from the charger holder

3. Clean the probe holder and the charger with an approved cleaning agent.
4. Disinfect the probe holder and the charger with an approved disinfectant; allow to dry for the manufacturer's recommended contact time.
5. Reassemble the probe charger on the charger.

12.8.8 Regulatory Requirements



Caution

The Qi compliant wireless charger supplied as an accessory with the product is verified for use with the Vscan Air CL probe. The wireless charger is considered to be information technology equipment that does not affect the basic safety or essential performance of the Vscan Air CL product. The wireless charger is compliant to the IEC/EN 62368-1 standard, which applies to audio/video, information and communication technology equipment.

The Vscan Air CL probe complies with regulatory requirements of the European Directive 93/42/EEC concerning medical devices.

Vscan Air Probe Charger Rating Plate



Figure 12-19 Vscan Air Model
GP200304 Rating Plate

12.8.9 Acoustic Output Reporting Tables for Track 3/EN/IEC 60601-2-37

The Ultrasound system (or Voluson Signature18/ Voluson Signature 20) does not control any acoustic output for the Vscan Air CL. For acoustic output reporting tables for the Vscan Air CL, refer to the manual provided by the manufacturer of the Vscan Air CL probe or on

<http://gehealthcare.com/usermanual>.

Note *These acoustic output reporting tables are produced according to IEC 62359 Ed.2.*

Note *The Acoustic Output tables are in English only.*

This page was intentionally left blank.

Chapter 13

Technical Data/ Information

- Safety conformance* ----- 13-2
- Physical Attributes* ----- 13-4
- System overview* ----- 13-6
- Screen Formats* ----- 13-8
- Display Modes* ----- 13-9
- Display annotation* ----- 13-10
- System Standard Features* ----- 13-14
- System Options* ----- 13-16
- System Parameters* ----- 13-18
- Scanning Parameters* ----- 13-23
- Generic Measurements and Measurements/Calculations* ----- 13-33
- External Inputs and Outputs* ----- 13-40
- Deep Learning Based Features* ----- 13-42

13.1 Safety conformance

The Voluson™ Signature 18 / Voluson™ Signature 20 system has been tested for EMC and is compliant with EN 55011 group 1 class A (CISPR 11 amendment 1) and IEC 60601-1-2.

Conformance details

Emission:	CISPR11, EN 55011	Group 1 Class A
	IEC/EN 61000-3-2	Power line harmonics
	IEC/EN 61000-3-3	flicker emissions
Immunity:	IEC/EN 61000-4-2	<ul style="list-style-type: none"> ± 2, ± 4, ± 8, ± 15 kV air discharge ± 8 kV contact discharge
	IEC/EN 61000-4-3	80MHz - 2.5 GHz, 3V/m For details see 'Guidance and manufacturer 's declaration' on page 2-39
	IEC/EN 61000-4-4	2kV burst on power lines
	IEC/EN 61000-4-4	1kV burst on data lines, length above 3m
	IEC/EN 61000-4-5	<ul style="list-style-type: none"> 2kV differential mode 1kV common mode
	IEC/EN 61000-4-6	150 kHz-80 MHz, 3Vrms (80% AM, 1kHz) For details see 'Guidance and manufacturer 's declaration' on page 2-39
	IEC/EN 61000-4-8	power frequency magnetic field For details see 'Guidance and manufacturer 's declaration' on page 2-39
	IEC/EN 61000-4-11	voltage dips For details see 'Guidance and manufacturer 's declaration' on page 2-39
	IEC/EN 61000-4-39	Radiated Fields in Close Proximity

Electrical safety:	IEC/EN 60601-1
Mechanical safety:	IEC/EN 60601-1
Thermal safety:	IEC/EN 60601-1
Mode of operation (duty cycle):	Continuous operation (100% on)
Safety classification:	Class I, applied parts type BF acc. to IEC60601 incl. national deviations
Safety classification with ECG	Class I & INTERNALLY POWERED EQUIPMENT , applied parts type CF, defibrillation-proof acc. to IEC60601 incl. national deviations
Ambient temperature:	<ul style="list-style-type: none"> 18°C to 30°C resp. 64°F to 86°F (operation temperature) -10°C to 50°C resp. 14°F to 122°F (storage and transport temperature)
Barometric pressure:	<ul style="list-style-type: none"> 700 to 1060 hPa (operation condition) 700 to 1060 hPa (storage and transport condition)
Humidity:	<ul style="list-style-type: none"> 30 to 80% RH no condensation (operation condition) 10 to 90% RH no condensation (storage and transport condition)
Humidity protection:	IPX0 no humidity protection IPX7 for transducer, IPX8 for foot switch IP44 for VSCAN Air Charger

Maximum operating altitude:	3000m; depending on the properties of the connected electronic devices the maximum operating altitude is limited to the altitude stated in the corresponding user manual of the connected electronic device. In the absence of altitude statements an altitude limitation up to 2000m is to be assumed, based on default IEC requirements.
Pollution degree:	2
Overvoltage category:	II
Material group:	IIIb
Light conditions	Natural & artificial light source (Bright light could impact readability of screen)

Serial number

Position: Rear side of the system on the identification plate.

Rating plate



Figure 13-1 Rating plate (example)



Figure 13-1 Rating plate (example)

Symbols

For more information see 'Description of symbols and labels' on page 2-3.

13.2 Physical Attributes

13.2.1 Dimensions / Weight / Audible noise emission

Width:	490 mm (19.3 in)	
Depth:	875 mm (34.4 in)	
Height:	Parking Position: 1240 mm (48.8 in) Operating min 1390 mm (54.7 in); max. 1790 mm (70.5 in) adjustable with user interface arm and monitor arm	
Weight:	Basic system (without accessories) approx. 73 kg Full configured system approx. 93 kg	
Audible noise emission:	Maximal:	≤65.0 dBA (measured at 0.3m meters away from the Ultrasound system in Maximum working mode for 3 hours)

13.2.2 Power Supply

Power requirements:	<ul style="list-style-type: none"> ● Protection Class I , Internally powered ● 100 V - 240 V AC ● Frequency: 50 Hz, 60 Hz (± 2Hz)
Power consumption:	<ul style="list-style-type: none"> ● Max. 650VA including all options ● Typical power consumption with ~ 195 VA load approx. 0.8 A at 230V/50Hz without peripherals
Thermal output:	Max. 2217 BTU/h
Fuse:	<ul style="list-style-type: none"> ● Part number : 0034.1526 ● Technical spec: <ul style="list-style-type: none"> <input type="radio"/> Rated voltage: 250VAC <input type="radio"/> Rated Current: 10A <input type="radio"/> Breaking Capacity: 10A @250VAC <input type="radio"/> Operation speed: 40ms

13.2.3 Operating panel Design

Ergonomic adaptability:	Adjustable in two dimensions: Swivel left-right: +/- 30° from center position Lift up-down: 250 mm (9.8 inch)
Hard key buttons:	Ergonomic layout, Interactive Back-Lighting
User-programmable hardkey-buttons (P1,P2,...):	4 user-programmable hardkey-buttons P1, P2, P3, P4 available for system-internal functions (e.g. screenshot) or external functions like remote control of Peripherals or Network-controlled devices (e.g. DICOM)
User-programmable hardkey-buttons (C1,C2,...):	4 user-Configurable hardkey-buttons C1, C2, C3, C4 available for system-internal functions (e.g. screenshot) or external functions like remote control of Peripherals or Network-controlled devices (e.g. DICOM)
Probe Ports:	4th Probe Port Activation is an option on Signature 18, It's standard on Signature 20.
Probe Holder:	5 integrated Probe holder and one TV holder on the left side (Option)
Gel Holder:	1 gel holder, optionally with gel warmer

Peripherals:	On-board storage for peripherals: e.g. Black/white printer, ECG
Wheels:	Wheel diameter 125 mm, 3 total lock and 1 directional lock
Cables:	Integrated cable management
Handles:	Front and rear handles

13.2.4 Monitor

Flat panel monitor (LCD):	23.8" high-resolution LCD LED Display with HDMI interface
Resolution:	FHD 1920 x 1080 pixel, 16:9
Max. brightness	300 cd/m ²
Tilt/Rotate:	<ul style="list-style-type: none"> ● tilt: + 25° / -70.5° ● rotate: +/- 90°
Controls:	<ul style="list-style-type: none"> ● Digital brightness & contrast adjustment ● Five default factory settings for warm and cold color temperature available: <ul style="list-style-type: none"> ○ Extra Dark, Dark-, Semi Dark-, Light- , Extra Light Room
Viewing angle:	Hor./Ver. greater or equal 170°
Contrast ratio:	1000:1
Safety classification:	IEC60950 or IEC62368-1 or equivalent

13.2.5 Touch Panel

Touch panel	14" capacitive Touch panel
Resolution	FHD 1920 x 1080 pixel, 16:9
Brightness	adjustable

13.3 System overview

Clinical applications:	<ul style="list-style-type: none">● OB● GYN● Vascular● Cardio● Abdominal● Small-Parts● Transrectal● Pediatrics● MSK● Cephalic● Breast
Scanning methods:	<ul style="list-style-type: none">● Electronic Sector● Electronic Convex● Electronic Linear● Mechanic Volume Sweep

<p>Transducer types:</p>	<ul style="list-style-type: none"> ● Sector Phased Array ● Convex Array ● Micro convex Array ● Linear Array ● Active Matrix Linear Array (1.25) ● Volume probes "4D": <ul style="list-style-type: none"> ○ Convex Array, Micro convex Array
<p>Operating modes:</p>	<ul style="list-style-type: none"> ● 2D-Mode ● M-Mode (conventional M-Mode) ● AMM (Anatomical M-Mode) ● PW Doppler Mode ● CW Doppler Mode ● High PRF Doppler Mode ● Color Flow Doppler Mode (CFM) ● Power Doppler Mode (PD) ● HD-Flow™ Doppler Mode (HD-Flow™) ● Tissue Doppler Mode (TD) ● B Flow Mode (BF) ● XTD-Mode ● Contrast Agent Mode (Contrast) ● M-Color Flow Modes (M/CF, M/HD-Flow™, M/TD) ● Elastography ● Shear Elasto ● Volume Modes (3D/4D): <ul style="list-style-type: none"> ○ 3D Static ○ 4D Real Time ○ VCI-A ○ VCI OmniView ○ STIC ○ 4D Biopsy

13.4 Screen Formats

2D Imaging:	<ul style="list-style-type: none"> ● Single (2D*) ● Dual (2D*+2D*) ● Quad (2D*+2D*+2D*+2D*) ● *2D = B, B-Flow, Contrast, B/CFM, B/PD, B/HD-Flow™, B/TD
TL Imaging:	<ul style="list-style-type: none"> ● B+TL** (Top/Bottom): 3 format sizes: 40/60, 50/50, 60/40% ● B+TL** (Side/Side): 50% / 50% ● B+AMM+AMM (Side/Top/Bottom): 50/25/25% ● **TL = M, AMM, PW, CW, M/CFM, AMM/CFM
3D/4D Imaging:	<ul style="list-style-type: none"> ● Render: quad (A/B/C/3D), triple (A/B/3D), dual (A/3D), single (3D) ● Multiplanar: quad (A/B/C), dual (A/B, A/C), single (A/B/C) ● OmniView: quad (Ref/1/2/3), dual (Ref/1,2 or 3), single (1,2 or 3) ● TUI: 1x1, 1x2, 2x2, 3x2, 3x3, 3x4, 4x4 ● Segmentation: quad (A/B/C/Segm. Object), single (Segm. Object)
Image Size	<ul style="list-style-type: none"> ● Standard format ● XL format ● Fullscreen format

13.5 Display Modes

Real time simultaneous capability:	<ul style="list-style-type: none"> ● in combination with SRI and/or CRI: <ul style="list-style-type: none"> ○ B/CFM, B/PD, B/HD-Flow™, B/TD, B+AMM,3D/CFM, 3D/PD, 3D/HD-Flow™, STIC/CFM, STIC/PD, STIC/HD-Flow™, STIC/TD B+B, B+B/CFM, B+B/PD or B+B/HD-Flow™ ● in combination with SRI: <ul style="list-style-type: none"> ○ 2D+M, 2D+PW, 3D/BF, 3D/Contrast, 4D/Contrast
Real time Triplex capability:	<ul style="list-style-type: none"> ● in combination with SRI: <ul style="list-style-type: none"> ○ 2D/CFM+PW, 2D/PD+PW, 2D/HD-Flow™+PW, 2D/TD+PW, 2D+M/CFM, 2D+M/HD-Flow™, 2D+M/TD, 2D+AMM/CFM, 2D+AMM/HD-Flow™, 2D+AMM/TD, 2D/CFM+AMM/CFM, 2D/HD-Flow™+AMM/HD-Flow™, 2D/TD+AMM/TD
Selectable alternating modes:	<ul style="list-style-type: none"> ● in combination with SRI and/or CRI: <ul style="list-style-type: none"> ○ 2D+PW, 2D+CW, 2D/CFM+PW, 2D/PD+PW, 2D/HD-Flow™+PW, 2D/TD+PW, 2D/CFM+CW, 2D/PD+CW, 2D/HD-Flow™+CW, 2D/TD+CW
Zoom Read / Write:	With or without overview image
Colorized Image:	colorized B, colorized M, colorized PW, colorized 3D
XTD:	split: Frame review / XTD-view

13.6 Display annotation

Patient Name:	Last, First, Middle: max 62 characters for all Patient Name fields
Patient ID:	max. 32 characters
Secondary patient ID (Citizen Service Number)	BSN, NHS, or free letter & number
Hospital Name:	max. 30 characters
Sonographer:	up to 32 characters are displayed depending on font size
Gestational age:	(OB) or LMP (Gyn)
Birth date:	(selectable)
Date:	3 Types selectable <ul style="list-style-type: none"> ● MM/DD/YYYY ● DD/MM/YYYY ● YYYY/MM/DD
Time:	2 types selectable: <ul style="list-style-type: none"> ● 24 hours ● 12 hours (optional AM/ PM in front or back)
Probe Name	
Application Name	
Gray Scale bar	
Frame Rate	
Zoom Factor	
B-Mode	<ul style="list-style-type: none"> ● Frame Rate ● Image Depth length ● Scan Angle ● Magnification Factor ● User preset ● Application ● Receiver Frequency ● Gain ● Dynamic Contrast ● Gray Map ● Edge Enhance ● Persistence ● SRI, CRI ● Focal Zone Markers ● Depth Scale Marker ● Probe Orientation Marker

M-Mode/AMM-Mode:	<ul style="list-style-type: none"> ● M-Gain ● Dynamic Contrast ● Edge Enhance ● Reject ● M-Cursor, AMM-Cursor ● Time Scale ● Display Annotations from B-Mode
PW-Mode:	<ul style="list-style-type: none"> ● PW-Gain ● Wall Motion Filter ● Angle correction ● Gate size ● Gate Depth ● Doppler Frequency ● PRF ● HPRF ● PW-Cursor, PW-Gate ● Velocity or Frequency Scale ● Time Scale ● Display Annotations from B-Mode
Color Flow Imaging Modes (CFM, PD, TD, HD-Flow™):	<ul style="list-style-type: none"> ● Color Gain ● CFM Frequency ● Color Balance ● Color Balance Marker ● Quality ● Wall Motion Filter ● PRF ● Color Map ● Color Scale: kHz, cm/s, m/s ● Power and Symmetrical Velocity Imaging ● Color Velocity Range ● Display Annotations from B-Mode ● Radianflow ● Slowflow

<p>3D/4D Mode:</p>	<ul style="list-style-type: none"> ● Header ● Volume Sweep Angle ● Volume Box Depth ● 3D/4D Render Preset ● Quality ● Smooth ● Mix ● Render Mode 1&2 ● Gray threshold ● Transparency Gray ● 3D Contrast ● 3D Brightness ● SRI, CRI ● Acquisition Mode ● Depth Scale Marker ● Compression ● Orientation Markers ● T.U.I.: slice distance (0.5-10mm) ● T.U.I.: slice position in overview image ● Acquisition Time (STIC only) ● Heart rate (STIC only) <p>Optional:</p> <ul style="list-style-type: none"> ● Header ● 2D User Program ● Receiver Frequency ● Gain ● Dynamic Contrast ● Gray Map
<p>Elastography Mode:</p>	<ul style="list-style-type: none"> ● Frequency ● Transparency ● Elasto Map ● Persistence ● Line Density ● Velocity Range ● Display Annotations from B-Mode
<p>Shear Elasto</p>	<ul style="list-style-type: none"> ● Gain ● Transparency ● Shear Elasto Map ● Sample Velocity Depth ● Frequency ● Penetration Depth
<p>TGC Curve</p>	
<p>Cine Frame Number</p>	
<p>Recorder Status</p>	
<p>Measurement Results</p>	

Displayed Acoustic Output	<ul style="list-style-type: none"> ● TIS: Thermal Index Soft Tissue ● TIC: Thermal Index Cranial (Bone) ● TIB: Thermal Index Bone ● MI: Mechanical Index ● Power output
Biopsy Guide Line	
ECG Line	
Trackball function	(Trackball and Trackball buttons)
GE HealthCare Logo	
Zoom overview image	(zoom box position)

13.7 System Standard Features

Note

Some operating modes may not be standard features for the Voluson™ Signature 18. For more information, refer to 'Overview options' on page 13-16

<p>Operating modes:</p>	<ul style="list-style-type: none"> ● B ● M (Conventional M) ● PW ● CFM (Color Flow Doppler Mode) ● PD (Power Doppler Mode) ● HD-Flow™ (HD-Flow™ Doppler Mode) ● TD (Tissue Doppler Mode) ● B-Flow ● Static 3D Mode: <ul style="list-style-type: none"> ○ B Mode only ○ B + Power Doppler Mode ○ B + CFM Doppler Mode ○ B + HD-Flow™ Mode ○ B + CRI ○ B + CRI + CFM ○ B + CRI + PD ○ B + CRI + HD-Flow™ ○ Contrast (dependent on contrast option) ○ B-Flow (dependent on B-Flow option) ● Automatic Tissue Optimization ● Coded Harmonic Imaging ● XTD ● SRI II (Speckle reduction imaging) ● CRI (Compound Resolution Imaging (Cross Beam)) ● High Resolution Zoom ● Pan Zoom ● Steering ● Virtual Convex ● Wide Angle ● Beta-View ● Inversion ● Real-time automatic Doppler calculations ● Patient information database ● Image Archive on hard drive ● 3D/4D data compression (lossy, lossless) ● 3D/4D package ● HDlive™
<p>Annotation (text) tool:</p>	<ul style="list-style-type: none"> ● Two independent text layers A, B ● Auto text memory: <ul style="list-style-type: none"> ● max 6300 terms with 24 characters; 35 terms (10 pages) for each application, 10 applications available

Body pattern tool:	160 types organized in 10 anatomical groups
Measurement & Calculation tools:	<ul style="list-style-type: none"> ● Including worksheets/reports for: <ul style="list-style-type: none"> ○ OB (includes Fetal Anatomy, Heart Function) ○ GYN (includes Findings, IOTA, IETA, IDEA) ○ Vascular ○ Cardio ○ Abdominal ○ Small-Parts (includes BI-RADS) ○ Transrectal ○ Pediatrics ○ MSK ○ Cephalic ○ Multigestational Calculations and Fetal Trending

13.8 System Options

13.8.1 Overview options

Overview of probes

	Voluson Signature 18	Voluson Signature 20
11L-D	x	x
ML6-15-D	x	x
9L-D	x	x
IC5-9-D	x	x
M5Sc-D	x	x
RAB6-D	x	x
C2-9-D	x	x
C1-5-D	x	x
C1-6-D	-	x
RIC5-9-D	x	x
x usable		
(x) probe fully supported, but not actively sold any more		
- not usable		

Overview of options

	Voluson Signature 18	Voluson Signature 20	additional Information
3D/4D Package	opt	std	Including SonoRenderLive
HDlive™	opt	std	-
HDlive™ Silhouette	-	opt	-
Advanced VCI with OmniView	opt	opt	Including Uterine Trace, Spine Trace
SonoGyn	opt	opt	Including Uterine Trace, Fibroid Mapping
Advanced STIC	opt	opt	-
SonoAVC™	opt	opt	Including Follicle Auto Caliper.
SonoVCADheart	opt	opt	-
Inversion	opt	opt	
VOCAL	opt	opt	-
Coded Contrast Imaging	opt	opt	-
Recording Module SW-DVR	opt	opt	-
Radiantflow	opt	opt	-
SlowflowHD	-	opt	-
SonoPelvicFloor 2.0	opt	opt	-
SonoCNS	opt	opt	-
SonoLyst	opt	std	-

	Voluson Signature 18	Voluson Signature 20	additional Information
SonoLystlive	opt	std	-
fetalHS	opt	opt	-
Elastography	opt	opt	-
Shearwave Elastography	opt	opt	Including Elastography Analysis
B-Flow	opt	std	-
XTD	opt	std	-
Scan Assistant	opt	std	-
4th Probe Port Activation	opt	std	-
VScan Air activation	opt	opt	-
Ophthalmic Artery	opt	opt	-
Advanced Security	opt	opt	-
Premium Security	opt	opt	-
Voluson Signature eDelivery	opt	opt	Extension Releases including OS Update
Voluson Remote Updates	opt	opt	OS Update
AVURI Device Management	opt	opt	-
Labor & Delivery Package	opt	opt	Including SonoL&D, SonoVCAD labor
opt = optional			
- = not available			
std = standard option			

13.9 System Parameters

13.9.1 System Setup

User Programmable Preset Capability, User program etc.	
Languages:	English, French, German, Spanish, Italian, Danish, Dutch, Finnish, Norwegian, Swedish, Chinese, Japanese, Russian, Portuguese
eIFU Languages:	Bulgarian, Chinese, Croatian, Czech, Danish, Dutch, English, Estonian, Finnish, French, German, Greek, Hungarian, Indonesian, Italian, Japanese, Kazakh, Korean, Latvian, Lithuanian, Norwegian, Polish, Portuguese, Romanian, Russian, Serbian, Slovakian, Slovenian, Spanish, Swedish, Turkish, Ukrainian, Vietnamese.
OSD Keyboard Layout	English, Danish, German, Swiss German, Finnish, French, Swiss French, Italian, Norwegian, Russian, Swedish, Spanish, Croatian, Polish
Up to 6300 Programmable Annotations organized in 10 anatomical groups	
Free programmable Scan Assistant lists	including Add, Delete, Edit and Reorder of checklist items
Four programmable Px buttons for documentation preferences	Save, DICOM Send, Print, Check, Cine length etc.
Four programmable C-Buttons	Several free programmable function as a shortcut, like mode changes, Scan Assistant functions, opening different menus.
Several user configurable functions	Clinic Name Display (TGC curve, Screen Lock, Screensaver, Auto Scan Stop) Beeper Trackball speed Dim function Zoom: Overview window Patient Info display Title bar settings Start Exam & End Exam Configuration

13.9.2 User Preset Memory

2D Presets:	Max. 8 preset folders per probe, max. 8 presets. Max. 64 presets per probe.
3D/4D Presets:	Max. 5 applications per probe, each application max. 8 Sub Presets; Max. 40 presets per probe

13.9.3 Measure Setup

Measure Setup	including Add, Delete, Edit and Reorder of measure items
Application Setup	including several parameters of Measurement, Doppler Trace and Calculation presets
Global Setup	including several parameters of Measurement, Cursor and Result window presets

13.9.4 Biopsy Setup

User programmable needle guidelines

13.9.5 Pre-Processing

B/M-Mode	Write Zoom 0.8x - 3.4x Gain TGC Dynamic Range Acoustic Output Transmission Focus Position Transmission Focus Number Transmission Frequency Persistence Control Line Density Control Reject Sweep Speed M-Cursor position
PW-Mode	Gain Dynamic Range Acoustic Output Transmission Frequency PRF Wall Motion Filter Sample Volume Gate Length, Depth, Pos Velocity Scale Sweep Speed
Color Flow Imaging Modes (CFM, PD, TD, HD-Flow™)	Gain Acoustic Output PRF Wall Motion Filter Line density Ensemble Dynamic Smooth (Rise and Fall) Frequency Balance Line Filter Quality

13.9.6 Post-Processing

B-Mode	Read Zoom: 0.8x - 3.4x Zoom (with HD-Zoom functionality up to 22x Zoom) 2D Gain Dyn. Contr. Edge Enhancement Gray Map Colorized B SRI II (Speckle Reduction Imaging)
M-Mode	Gray Map Edge Enhancement Colorized M Display Format Sweep Speed
PW Mode	Gray Map Baseline Shift Angle Correction Colorized D Scale (KHz, m/s, cm/s) Trace Invert Sweep Speed
Color Flow Imaging Modes (CFM, PD, TD, HD-Flow™)	Color Map Display Threshold Display Mode: V, V-T, T, P, P-T (CFM only) Scale (CFM and HD-Flow™) Baseline B-Flow Gray Map Radiantflow (probe dependent and application specific dependent)
BF	Gray Map Colorized BF SRI II (Speckle Reduction Imaging) Dyn. Contr.

13.9.7 Image Processing and Presentation

Digital Beamformer	
Max. processing channels (probe dependent)	3,019,165 (probe dependent)
Minimum Depth of Field:	1 cm (Zoom, probe dependent)
Max. Depth of Field:	50 cm (probe dependent)
Max. effective Depth probe dependent	50 cm (C1-6-D)
Transmission Focus:	1- 5 Focus Points selectable (probe dependent)
Focal Zone position	up to 10 steps (probe dependent)
Continuous Dynamic Receive Focus / Continuous Dynamic Receive Aperture	
Gray	256

Colors	16.8 Mio, 24 bit
Calculated DR (B + CF)	Up to 265 dB Dynamic Range
Image Reverse	Right/ Left
Rotation	0°, 90°, 180°, 270°

13.9.8 2D CINE Features/Length

Cine Features:	<ul style="list-style-type: none"> • Dual/Quad Image CINE Display • CINE Gauge and CINE Image number display • CINE Review Loop • Selectable CINE Sequence for CINE Review (by Start Frame and End Frame) • Side Change in dual CINE Mode • Measurements/Calculations & Annotations on CINE
Length:	<ul style="list-style-type: none"> • 512MB: up to 10 min. (depending on B-image size and FPS) • typical: about 3min/4000 images (with curved array: 15cm depth, angle 81 °, 22 FPS)
Cine operation:	<ul style="list-style-type: none"> • manual: image by image • auto run: speed: 25 to 200% of real-time rate • play repeat mode: forward-forward, forward-backward-forward
Exported as:	<ul style="list-style-type: none"> • Strain analysis: xml

13.9.9 Image/Volume Storage (Archive)

Image data stored as:	<ul style="list-style-type: none"> • Raw data file (proprietary format) • DICOM file (Single- or Multiframe)
Volume file stored as:	<ul style="list-style-type: none"> • Raw data file (proprietary format) • Size: typically: 0.8 - 5 MB (depending on probe and adjusted volume size)
Compression:	<ul style="list-style-type: none"> • 2D: JPEG, lossless, high, mid, low • 3D/4D: Lossy and lossless compression available <p>Typical compression rates are 50% with lossless compression, 15% with lossy compression but maximum quality and 5% with lossy compression and reduced quality (approximate values).</p>
Review:	<ul style="list-style-type: none"> • Review of current Exam and archived data sets (Single Images and Cine Clips) • View Format: Raw data, DICOM data • Display Formats: 1x1, 3x3
Reload:	<p>Reload of current/ archived data sets:</p> <ul style="list-style-type: none"> • 2D Raw Data (incl. Color Doppler, Spectral Doppler and M-Mode) • 3D Raw Data (Single Volume incl. Calc. Cines) • 4D Raw Data (Volume Cine)

Export as:	<ul style="list-style-type: none"> ● Still image: JPEG (.jpg), BITMAP (.bmp), TIFF (.tif), PNG (.png) ● Video format: AVI (.avi), MP4 (.mp4) ● Raw files: RAW (2D), VOL (Volume data), 4DV (RAW, VOL incl. Patient data – password protected) ● DICOM Files: DCM, DICOM Files with DICOMDIR ● 3D Raw Data: export Cartesian format possible ● Surface formats: STL, OBJ, PLY, 3MF, XYZ (with projected and full 3D export capabilities)
AVI Codec:	MS Video 1
Export to:	Network, USB devices, Email
Export Anonymous function:	available for following image types: AVI, BMP, TIFF, JPEG, PNG, MP4, 4DV
Backup function to:	Network, USB devices
Repro function	Settings recall (e.g. Geometry, Gain, Colormap, etc.) from a stored or reloaded picture
Exam History:	<ul style="list-style-type: none"> ● direct access to images from previous exams ● direct access to Measure Reports images from previous exams ● Image compare window on screen to compare images from previous exams with current exam image
Anonymize Archive	Fully anonymized Archive with own Patient ID
Hard Drive Data storage space	Approx. 450 GB

13.9.10 Connectivity

<ul style="list-style-type: none"> ● Ethernet network connection ● USB for USB devices ● DICOM support (option): <ul style="list-style-type: none"> <input type="radio"/> Verify <input type="radio"/> Print <input type="radio"/> Store <input type="radio"/> Modality Worklist <input type="radio"/> Structured Reporting <input type="radio"/> Storage Commitment <input type="radio"/> MPPS (Modality performed procedure step) <input type="radio"/> Media Exchange <input type="radio"/> Off network / mobile storage queue <input type="radio"/> Query/Retrieve <input type="radio"/> TLS

13.10 Scanning Parameters

13.10.1 B-Mode

Acc. power range:	1 - 100
Scan angle:	depends on used probe
GAIN range:	+15 to -25 dB
Gray scale values:	8 bit (256 gray values)
SRI	6 steps (0-5)
CRI	8 steps (1-8)
CRI filter	4 steps: off, low, mid, high
Persistence filter:	8 steps (pre)
Line filter:	3 steps (pre) off, low (12,5/75/12,5%), high (25/50/25%)
Line density:	3 steps (pre) low, norm, high
Reject:	51 steps (pre) from 0 to 255
Enhance:	6 steps (0-5)
Gray maps:	21 (18 basic maps and 3 user-defined maps)
Tint maps:	10
Dynamic:	Range: 1-12 Step size: 0,5
Display modes:	B, XTD, Fullscreen
Screen formats:	<ul style="list-style-type: none"> ● 2D imaging: Single (B), Dual (B+B), Quad (B+B+B+B) ● XTD View: Single (XTD), Dual (B+XTD)
Max. B-Mode Frame Rate	> 3600 frames/sec (probe dependent)

13.10.2 M-Mode

Working modes:	M (conventional M-Mode) / AMM (Anatomical M-Mode)
Power control range:	1 - 100
GAIN range:	+15 to -25 dB
M sweep speeds:	<ul style="list-style-type: none"> ● 900 / 450 / 300 / 225 / 150 / 100 pixels/sec.; ● 26.44 / 13.22 / 8.81 / 6.61 / 4.40 / 2.94 cm/s in relation to system monitor
Review (memory times):	> 60 s (32MB)
Signal processing M:	<ul style="list-style-type: none"> ● Dynamic range: 1 to 12, step size 0,5 ● Reject: 0 to 255 ● Enhance: 0 to 5 ● Gray maps: 18 ● Tint maps: 10

Display Modes:	<ul style="list-style-type: none"> ● M: 2D+M, 2D+M/CFM, 2D+M/HD-Flow™, 2D+M/PD, 2D+M/TD ● AMM: 2D+AMM, 2D/CFM+AMM/CFM, 2D/HD-Flow™+AMM/HD-Flow™, 2D/TD+AMM/TD
Screen formats:(window arrangement)	<ul style="list-style-type: none"> ● 2D+M and 2D+AMM: up/down (horizontal): three different sub formats 30/70, 50/50, 70/30%; left/right (vertical): 50/50% ● 2D+AMM+AMM: left//rt-up/rt-down: 50//25/25%

13.10.3 M-CFM-Mode

Acoustic MCFM Power	1-100%
MCFM Color Maps	8 maps
CFM Gain	+/-15 dB range, 0,1 dB steps
CFM Velocity Scale Range	PRF: 100Hz to 20,5kHz
Wall Motion Filter	8 - 3000 Hz
Ensemble (color shots per line)	8-16, step size 1
Gentle color filter	Gentle color filter
Smooth filter	Rise: 12 steps Fall: 12 steps
CFM Spectrum Inversion	
CFM Baseline Shift	17 steps
Pre-settable and independently adjustable B-, M and MCFM Gain	
CFM Threshold	1 - 255 steps
Balance	25 - 255, step size 5
Artifact suppression	On/Off
Color Display Mode	<ul style="list-style-type: none"> ● V (Velocity) ● V-T (Velocity + Turbulence) ● V-P (Velocity + Power) ● T (Turbulence) ● P-T (Power + Turbulence)
Radiantflow	Off, Min, Mid, Max (probe dependent and application specific dependent)
Real-time Triplex Mode	B + M + MCFM in any depth

13.10.4 Spectral-Doppler PW / CW

Operating Modes:	<ul style="list-style-type: none"> ● PW (Pulsed Wave Doppler, Single Gate) ● CW (Continuous Wave Doppler)
Transmit frequencies:	<ul style="list-style-type: none"> ● PW-Doppler: 1.75-18 MHz ● CW-Doppler: 1.75-16 MHz
Pulse Repetition Frequency(PRF):	<ul style="list-style-type: none"> ● PW-Doppler: 0.9-22.0 KHz ● CW-Doppler: 1.3-41.7 KHz
Sample Volume (Doppler Gate)	<ul style="list-style-type: none"> ● Length: 0.1, 0.7, 1, 2, 3, 4, 5, 6, 7, 8, 9, 10, 15, 20 mm ● Angle correction: + 85°... 0°... + 85°
Power control range:	1 - 100%

GAIN range:	<ul style="list-style-type: none"> ● + 15 to - 25dB (PW) ● + 15 to - 15dB (CW)
WMF (wall motion filter):	PW: 30 - 500Hz CW: 30 - 1000Hz
Zero line shift:	± PRF/2, ± 8 steps
Spectrum Analyzer:	max. 256 frequencies, 256 amplitude levels
PW sweep speeds:	<ul style="list-style-type: none"> ● Simplex (26,44 / 13.22 / 8.81 / 6.61 / 4.40 / 2.94 cm/s) ● Duplex/Triplex (26.44 / 13.22 / 8.81 / 6.61 / 4.40 / 2.94 cm/s)
Review (memory times):	>60 s (32MB)
Measurable flow velocities:	<ul style="list-style-type: none"> ● PW: <ul style="list-style-type: none"> ○ 1cm/s - 8m/s (a = 0°, 2.0MHz, max. zero shift) ○ 1cm/s - 16m/s (a = 60°, 2.0MHz, max. zero shift) ● CW: <ul style="list-style-type: none"> ○ 1cm/s - 11.60m/s (a = 0°, 2.0MHz, max. zero shift) ○ 1cm/s - 23.20m/s (a = 60°, 2.0MHz, max. zero shift)
Signal processing:	<ul style="list-style-type: none"> ● Dynamic range: 15 steps (10 to 40) ● Gray maps: 18 basic curves and 3 User-defined (pre, post) ● Tint maps: 11
Scale Display	<ul style="list-style-type: none"> ● Vertical: kHz, cm/s, m/s (selectable) ● Horizontal: 1s marker (big), 1/2 s marker (small)
Screen formats:	<ul style="list-style-type: none"> ● 2D/D: up/down (horizontal): three different sub formats 30/70, 50/50, 70/30% left/right (vertical): 50/50%
Display Formats:	<ul style="list-style-type: none"> ● 2D/D (duplex update, simultaneous) ● 2D+CFM/D, 2D+HD-Flow™/D, 2D+PD/D, 2D+TD/D (triplex update) ● 2D+CFM/PW, 2D+PD/PW, 2D+HD-Flow™/PW, 2D+TD/PW, (triplex simultaneous, PW only)
Audio-Modes:	Stereo (both directions separately in both channels)
Audio Volume:	Adjustable

13.10.5 TD/PW

Operating Modes:	2D+TD/PW (Tissue Doppler + Pulsed Wave Doppler, Single Gate)
Transmit frequencies:	1.75 - 18 MHz
Pulse Repetition Frequency (PRF):	<ul style="list-style-type: none"> ● TD/PW: 0.9 - 7.0 kHz
Sample Volume (Doppler Gate)	<ul style="list-style-type: none"> ● Length: 0.7, 1, 2, 3, 4, 5, 6, 7, 8, 9, 10, 15 mm ● end Angle correction: + 85°... 0°... + 85°
Power control range:	1 - 100
GAIN range:	<ul style="list-style-type: none"> ● 2D: + 15 to - 25dB ● PW: + 15 to -25dB ● TD: + 15 to -15dB
WMF (wall motion filter):	30 - 500Hz
Zero line shift:	± PRF/2, ± 8 steps
Spectrum Analyzer:	max. 128 frequencies, 256 amplitude levels

PW sweep speeds:	<ul style="list-style-type: none"> Duplex/Triplex (26.44 / 13.22 / 8.81 / 6.61 / 4.40 / 2.94 cm/s)
Review (memory times):	>60 s (32MB)
Measurable flow velocities:	<ul style="list-style-type: none"> 1cm/s - 2.6m/s ($\alpha = 0^\circ$, 2.0MHz, max. zero shift) 1cm/s - 4.9m/s ($\alpha = 60^\circ$, 2.0MHz, max. zero shift)
Signal processing:	<ul style="list-style-type: none"> Dynamic range: 15 steps (10 to 40) Gray maps: 18 basic curves and 3 User-defined (pre, post) Tint maps: 11
Scale Display	<ul style="list-style-type: none"> Vertical: kHz, cm/s, m/s (selectable) Horizontal: 1s marker (big), 1/2 s marker (small)
Screen formats:	2D + TD/PW: up/down (horizontal): three different sub formats: 30/70, 50/50, 70/30%, left/right (vertical): 50/50%
Display Formats:	<ul style="list-style-type: none"> 2D+ TD/PW (duplex update, simultaneous) 2D+ TD/PW (triplex update) 2D+ TD/PW (triplex simultaneous)
Audio-Modes:	Stereo (both directions separately in both channels)
Audio Volume:	Adjustable

13.10.6 Color Doppler

Screen formats:	2D+CFM (single, dual, quad)
Display modes:	<ul style="list-style-type: none"> Simultaneous dual mode: 2D/2D+CFM Triplex mode: 2D+CFM/PW, 2D/M+MCFM Volume Mode: 3D+CFM
Color coding:	<ul style="list-style-type: none"> steps: 65536 color steps Display modes: <ul style="list-style-type: none"> <input type="radio"/> V-T (velocity + turbulence) <input type="radio"/> V (velocity) <input type="radio"/> V-P (velocity + power) <input type="radio"/> T (turbulence) <input type="radio"/> P-T (power + turbulence)
Depth range:	<ul style="list-style-type: none"> axial: 0 to B scan range lateral: 0 to B scan range
Baseline shift:	17 steps (independent from spectral Doppler)
Inversion of color direction:	yes
Wall Motion Filter:	7 steps (low1, low2, mid1, mid2, high1, high2, max)
Smoothing Filter:	<ul style="list-style-type: none"> 12 steps rising time 12 steps falling time
Gain control:	+15dB to -15dB, 0.2dB steps
Line Density (color line density):	10 steps
Ensemble (color shots per line):	<ul style="list-style-type: none"> CFM: 7 to 31 MCFM: 8 to 16
Flow Resolution:	4 steps (low, mid1, mid2, high)

Pulse repetition frequency:	<ul style="list-style-type: none"> ● CFM: 25Hz to 20.5kHz ● MCFM: 25Hz to 20.5kHz
Color Map:	<ul style="list-style-type: none"> ● V-T: 8 ● V: 8 ● V-P: 7 ● T: 1 ● P-T: 1
Frequency range:	1 to 18 MHz depending on the probe, adjustable in 3 steps (low, mid, high)
Balance:	from 25 to 225
Max. meas. velocity:	4.23 m/sec.
Min. meas. velocity:	0.3 cm/sec.
Scale:	kHz, cm/s, m/s
Radiantflow	Off, Min, Mid, Max (probe dependent and application specific dependent)
Automatic moving tissue suppression:	yes
Max. Color Doppler Frame Rate	> 990 frames/sec

13.10.7 Power-Doppler

Screen formats:	2D+PD (single, dual, quad)
Display modes:	<ul style="list-style-type: none"> ● Simultaneous dual mode: 2D/2D+PD ● Triplex mode: 2D+PD/PW ● Volume Mode: 3D+PD;
PD coding steps:	256 color steps
PD window size:	<ul style="list-style-type: none"> ● lateral: maximum to minimum B mode scan angle ● axial: B-scan range
Display mode:	P (power)
Wall motion Filter:	7 steps (low1, low2, mid1, mid2, high1, high2, max)
Smoothing Filter:	<ul style="list-style-type: none"> ● rising edge: 12 steps ● falling edge: 12 steps
Gain control:	+15dB to -15dB, 0.2dB steps
PD Ensemble:	7 to 31
PD Line Density:	10 steps
Pulse repetition frequency:	100Hz to 20.5kHz
PD Map:	8 different color codes for each probe
Radiantflow	Off, Min, Mid, Max (probe dependent and application specific dependent)
Frequency range:	1 to 18 MHz depending on the probe, adjustable in 3 steps (low, mid, high)
Flow Resolution:	4 steps (low, mid1, mid2, high)
Balance:	from 25 to 225 in 41 steps
Artefact suppression:	yes

13.10.8 HD-Flow™ Mode (HDF)

Screen formats:	2D+HDF (single, dual, quad)
Display Modes	<ul style="list-style-type: none"> ● Simultaneous dual mode: 2D/2D+HDF ● Triplex mode: 2D+HDF/PW; 2D/M+MHDF ● Volume Mode: 3D+HDF
HD-Flow™ Coding Steps:	256 color steps
HD-Flow™ window size:	<ul style="list-style-type: none"> ● lateral: maximal to minimal B mode scan angle ● axial: B-scan range
Display mode:	P (power)
Wall Motion Filter:	7 steps (low1, low2, mid1, mid2, high1, high2, max)
Smoothing Filter:	<ul style="list-style-type: none"> ● 12 steps rising edge; ● 12 steps falling edge;
Gain Control:	+15dB to -15dB, 0.2dB steps
HD-Flow™ Ensemble:	7 to 31
HD-Flow™ Line Density:	10 steps
Pulse Repetition Frequency:	100Hz to 20.5KHz
HD-Flow™ Map:	8 different color codes for each probe
Radiantflow	Off, Min, Mid, Max (probe dependent and application specific dependent)
Frequency Range:	1 to 18 MHz depending on the probe adjustable in three steps (low, mid, high)
Flow Resolution:	4 steps (low, mid1, mid2, high)
Balance:	from 25 to 225
Artefact suppression:	yes

13.10.9 Tissue Doppler Mode (TD)

Screen formats:	2D+TD (single, dual, quad)
Display modes:	<ul style="list-style-type: none"> ● Simultaneous dual mode: 2D/2D+TD ● Triplex mode: 2D+TD/PW, 2D/M+MTD
TD coding steps:	65536 color steps
Depth range:	<ul style="list-style-type: none"> ● axial: 0 to B-scan range ● lateral: 0 to B-scan-range
Zero line shift:	17 steps
Inversion of color direction:	yes
Smoothing Filter:	<ul style="list-style-type: none"> ● 12 steps rising time ● 12 steps falling time
Gain control:	+15dB to -15dB, 0.2dB steps
Line Density (color line density):	10 steps
Ensemble (color shots per line):	3 to 31
Flow Resolution:	4 steps (low, mid1, mid2, high)
Pulse repetition frequency:	100 Hz to 20.5 kHz
TD Map:	4 different color codes for each probe

Frequency range:	1 to 18 MHz depending on the probe, adjustable in 3 steps (low, mid, high)
Balance:	from 25 to 225
Max. meas. velocity:	4.23 m/sec.
Min. meas. velocity:	0.3 cm/sec.
Display Mode:	V (velocity)
Scale:	kHz, cm/s, m/s

13.10.10 Volume Scan Module

Vol. scan size:	<ul style="list-style-type: none"> ● max. 128 MB for gray volumes ● max. 180 MB for color volumes ● The required memory space depends on scan parameters (VOL-box size and quality (low, mid1, mid2, high1, high2, max). typical: 0.8-5 MB
Lines/2D-image:	max. 1024 (typ. 80 to 350)
2D-images/volume:	max. 4096 (dependent on acquisition mode)
VOL-Frames/sec.:	<ul style="list-style-type: none"> ● max. 812 Vol/sec typical : 7-12 Vol/sec ● The frame rate depends on scan parameters: VOL-Box size, quality and probe.
4D Volume Cine:	up to 400 volumes up to 1024 MB
Display of sectional plane images:	synchronous with control setting, arbitrary movement in volume, monitored position in volume.
Rotation:	360°, 1° or 3° increments (X-, Y- and Z-axis)
Magnification:	adjustable from 0.3 to a factor of 4.00
Acquisition Modes:	<ul style="list-style-type: none"> ● 3D Static: <ul style="list-style-type: none"> <input type="radio"/> 3D (2D incl. CRI) <input type="radio"/> 3D/PD (incl. CRI) <input type="radio"/> 3D/CFM (incl. CRI) <input type="radio"/> 3D/HD-Flow™ incl. CRI) <input type="radio"/> 3D B-Flow <input type="radio"/> 3D Contrast: 3D/Contrast (Coded PI, CCIS) ● 4D Real Time <ul style="list-style-type: none"> <input type="radio"/> 4D RT <input type="radio"/> 4D Biopsy <input type="radio"/> VCI-A <input type="radio"/> VCI- OmniView ● STIC: <ul style="list-style-type: none"> <input type="radio"/> Fetal Cardio <input type="radio"/> STIC Angio: B/Power Doppler (incl. CRI) <input type="radio"/> STIC CFM: B/Color Doppler (incl. CRI) <input type="radio"/> STIC HD-Flow™: B/HD-Flow™ (incl. CRI) <input type="radio"/> STIC B-Flow <input type="radio"/> STIC TD

<p>Visualization Modes:</p>	<ul style="list-style-type: none"> ● Render <ul style="list-style-type: none"> ○ 3D Rendering (diverse surface and intensity projection modes) ○ SonoRender<i>live</i> ● Sectional Planes <ul style="list-style-type: none"> ○ Multiplanar ○ OmniView, actual –and projected view (Option) ○ Niche ○ SonoVCAD™<i>labor</i> ● TUI (Tomographic Ultrasound Imaging (overview image + parallel slices) <ul style="list-style-type: none"> ○ TUI Standard ○ SonoVCAD™<i>heart</i> ● Volume Analyses <ul style="list-style-type: none"> ○ VOCAL: semi-auto/ manual segmentation tool using touch screen, 3D Static only + Threshold Volume ○ Spine Trace ○ Uterine Trace ○ SonoAVC™<i>antral</i>^{2.0} ○ SonoAVC™<i>follicle</i> (Sono Automated Volume Count) ○ SonoAVC™<i>general</i> ○ SonoCNS ○ SonoPelvicFloor^{2.0} ● VCI (Volume Contrast Imaging) ● free moveable light source for 3D objects: <ul style="list-style-type: none"> ○ 3D Rendered Image ○ VOCAL object ○ SonoAVC™ object
<p>Render Modes:</p>	<ul style="list-style-type: none"> ● HD<i>live</i> Silhouette ● Transparency modes: max, min and X-ray ● Gradient Light ● Inversion ● Glass Body ● Surface Smooth ● Surface Texture ● Mix Mode of two render modes ● Color ● Surface Enhanced ● HD<i>live</i> ● Light
<p>Display graphics:</p>	<ul style="list-style-type: none"> ● Rotation axis, center point ● ROI box, 3D Frame
<p>Gray maps:</p>	<ul style="list-style-type: none"> ● Slices: 21 (18 basic curves and 3 User-defined (pre, post) ● 3D Image: one general map adjustable brightness (0-100) and contrast (0-100)
<p>Tint maps:</p>	<ul style="list-style-type: none"> ● Slices: 10 ● 3D image: 10
<p>Depth render maps:</p>	<p>3</p>

13.10.11 BF (B-Flow)

Screen formats:	single (BF), dual, (BF+BF), quad (BF+BF+BF+BF)
Display modes:	<ul style="list-style-type: none"> ● BF ● Update: BF/PW
Acoustic Power range:	1 - 100%
Scan angle:	taken from 2D
GAIN range:	+15 to -25 dB
Gray scale values:	8 bit
SRI	taken from 2D
Persistence filter:	8 steps (pre)
S./PRI	1.00, 1.25, 1.50, 1.75, 2.00, 3.00, 4.00, 5.00....15
Quality:	3 steps (pre) low, norm, high
Enhance:	6 steps (pre) 0 - 5
Gray maps:	21 (18 basic maps and 3 user-defined maps)
Tint maps:	10
Dynamic:	Range 1-12 Step size 0,5
Accumulation:	Off, 0.05, 0.10, 0.20, 0.40, 0.60, 0.80, infinite
Background:	0, 1, 2

13.10.12 Contrast (Agent)

Acoustic Power range:	1 - 100
Scan angle:	taken from 2D
GAIN range:	+15 to -25 dB
Gray scale values:	32 bit
SRI	taken from 2D
Persistence filter:	8 steps (pre)
S./PRI	1.00, 1.50, 2.00, 3.00, 4.00....15.00
Quality:	3 steps (pre) low, norm, high
Enhance:	6 steps (pre) 0 - 5
Gray maps:	21 (18 basic maps and 3 user-defined maps)
Tint maps:	10
Dynamic:	Range: 1-12 Step Size: 0,5
Accumulation:	Off, 0.20, 0.35, 0.50, 0.75, 1.00, 1.50, Infinite
Background:	0, 1, 2
Time delay:	0, 0.5, 1, 2, 3,10

Screen formats:	<ul style="list-style-type: none"> ● Code PI: Single (B), Dual (B+B), Quad (B+B+B+B) ● CIS: Dual simultan (2D + Coded PI) ● CCIS: Single (B), Dual (B+B), Quad (B+B+B+B)
Display modes:	<ul style="list-style-type: none"> ● Coded PI ● Coded PI: CIS ● Coded PI: CCIS

13.10.13 Elastography

Acoustic Power Range:	1 - 100%
Tx Frequency	3 (penet/norm/resol)
Transparency	51 steps (0, 5, 10 ... 255)
Soft Compress	Range: 0 - 9; step size 1
Hard Compress	Range: 0 - 9; step size 1
PRF	10, 15, 25, 40, 60, 85 Hz
Elasto Maps	8
Persistence	Range: 1 - 9; step size 1
Line Dens.	Range: 1 - 2
Filter Axial	Range: 1 - 9; step size 1
Filter Lateral	Range: 1 - 21 step size 2
Window Length	Range: 8 - 25; step size 1
Screen Formats	<ul style="list-style-type: none"> ● Single (2D/Elasto) ● Dual (2D/Elasto+2D/Elasto) ● Quad (2D/Elasto+2D/Elasto+2D/Elasto+2D/Elasto)

13.10.14 Shear Elasto

Acoustic Power Range	1 - 100%
Transparency	51 steps (0, 5, 10 ... 255)
Scale	2,0; 2,6; 3,0; 3,2; 3,7; 4,0; 4,1; 4,5; 4,8; 5,0; 5,2; 5,5; 5,8; 6,0; 6,5; 7,1; 7,5; 7,6; 8,0; 8,2; 9,1; 10,0
Shear Elasto Maps	8
Screen Formats	Single

13.11 Generic Measurements and Measurements/Calculations

13.11.1 Generic Measurements

2D Mode and 3D:	Distance:	Distance (Point to Point), Distance (Line to Line), 2D Trace (Trace Length&Point), Stenosis (% Dist), Ratio D1/D2
	Area/Circumference:	Ellipse, Trace (Line & Point), Area (2 Dist) Stenosis (% Area), Ratio A1/A2
	Volume:	1 Distance, 1 Ellipse, 1 Dist. + Ellipse, 3 Distances , Multiplane - planimetric volume (3D only)
	Angle:	Angle (3 Point), Angle (2 Line)
M Mode:	Generic	Distance, Slope, Time, HR (Heart Rate), Stenosis (% Dist)
	Gen. Vessel	IMT, Vessel Diam., Stenosis Diam., Time, HR
Doppler Mode:	Generic Lt/Rt Gen Vessel	Single Measurements: <ul style="list-style-type: none"> • Velocity, Acceleration, RI, PI, PS, ED, PS/ED, Time, HR Auto & Manual Trace measurements (depending on measurement package): <ul style="list-style-type: none"> • PS (Peak Systole), ED (End Diastole), MD (Mid Diastole), PS/ED (Ratio), PI (Pulsatility Index), RI (Resistance Index), TAmx (Time avg. max.Velocity), Tamean (Time avg. mean velocity), VTI (Velocity Time Integral), Heart Rate, Vol. Flow
	PG	PGmax, PGmean

13.11.2 Calculations

Abdomen:	Liver, Gallbladder, Pancreas, Spleen, Left/Right Kidney, Left/Right Renal Artery, Aorta (Proximal, Mid, Distal), Portal Vein, Vessel, Bladder Volume, Bladder all included in Summary Reports	
Small Parts: Default	Left/Right Thyroid, Left/Right Testicle, Vessel, Left/Right Dorsal Penile Artery all included in Summary Reports	
Small Parts: Breast	Left/Right Lesions 1 -5; all included in Summary Reports	
Obstetrics:	2D:	Fetal Biometry, Early Gestation, Fetal Long Bones, Fetal Cranium, AFI, Uterus, Left/Right Ovary, Left/Right Uterine, Umbilical Vein, Fract Limb Vol. , NT method: auto/manual, Placenta Volume
	M:	Generic, FHR (FHR, Atrial, FHR)
	Doppler:	Ductus Art., Ductus Ven.,Ao, Carotid, MCA, Celiac Artery, Superior Mesenteric Artery, Umbilical Art., Umbilical Vein, Uterine Art., FHR
	Gestational Age Calculation, Gestational Growth Calculation, Fetal Weight (FW) Estimation, Fetal Trend Graph, Multi-Gestational Calculation & Fetal Compare, Calculation and Ratios, Fetal Qualitative Description (Anatomical survey), Fetal Environmental Description (Biophysical profile); all included in Summary Reports	
Obstetrics: Fetal Echo:	2D:	Chambers, Thorax, Aorta/LVOT, Pulmonary/RVOT, Venous, Cardiac Analysis
	Doppler:	Mitral Valve, Tricuspid valve, Aortic, Pulmonary, LPA, RPA. Ductus Art., Cardiac Output, FHR, Rt. TEI, Lt. TEI, Ductus Ven., Umbilical Vein, Pulmonary Veins all included in Summary Reports
	M:	Chambers, Aorta/LVOT, Pulmonary/RVOT, FHR

Obstetrics: Z-Scores	Calculation of Z-Scores for: Long Axis, Aortic Arch, Short Axis, Obl. Short Axis, 4 Chamber; all included in Summary Reports	
Cardiology:	2D Mode:	Simpson (Single), Volume (Area Length), LV-Mass (Epi & Endo Area, LV Length), LV (RVD, IVS, LVD, LVPW), LVOT Diameter, RVOT Diameter, MV (Dist A, Dist B, Area), TV (Diameter), AV/LA (Aortic Valve/LeftAtrium), PV (Diameter), Pericard. effusion, C Mode: PISA;
	M Mode:	LV (IVS, LVD, LVPW, RVD), AV/LA (Ao Root Diam, LA Diam, AV Cusp Sep., Ao Root Ampl.), MV (D-E, E-F Slope, A-C Interval, EPSS), HR (Heart Rate), HR (HR, Atrial HR)
	D Mode:	MV (Mitral Valve), AV (Aortic Valve), TV (Tricuspid Valve), PV (Pulmonary Valve), LVOT & RVOT (Left & Right Ventricle Outflow Tract), Pulmonic Veins, PAP (Pulmonary Artery Pressure measurement), HR (Heart Rate) , TEI-Index
	Others:	Diast. Vol.(Bi), Syst.Vol.(Bi), Stroke Volume, Volume Flow, Cardiac Output, Ejection Fraction, Fractional Fract. Shortening, Myocardial Thickness, LA/Ao Ratio, E/A Peak , Peak Gradient Acceleration, Mean Gradient, Mean Gradient Acceleration, VTI, TVA, PG, PHT, MVA, AVA, ERO, CVP (Cardio Vascular Profile) Score etc.
	all included in Summary Reports	
Transrectal:	Prostate all included in Summary Reports incl. PSAD, PPSA(1), PPSA(2) calculation	
Vascular:	Carotid:	CCA, ECA, ICA, Bulb, Vertebral, Subclav., Vessel
	UEA:	SUBC A, AXILL A, BRACH A, RADIAL A, ULNAR A, GRAFT, Palm A, INNOM A
	UEV:	JUGUL, INNOM V, SUBC V, AXILL, CEPH, BASIL, BRACH, MCUB, RADIAL, ULNAR
	LEA:	COM ILIAC A, EXT ILIAC A, INT ILIAC A, COM FEM A, DEEP FEM A, SUP FEM A, POPL A, ANT TIB A, POST TIB A, PERON A, DORS PED A, GRAFT, PROF A
	LEV:	IVC, COM ILIAC V, EXT ILIAC Vein, COM FEM, GSAPH V, FEM V, DEEP FEM V, POPLIT V, L SAPH V, ANT TIB V, POST TIB V, PERON V, PROF V
	Renal:	RENAL A, M RENAL A, RENAL V, SEGM A, INTERLO A, ARC A
	TCD:	ACA, MCA, PCA, Basilar, A Comb.A, P Comb.A, Vertebral, Vessel, Basilaris
	all included in Summary Reports	
Gynecology:	Uterus, Right/Left Ovary Right/Left Follicle, Fibroid, Endometrial thickness (Dist., Double Dist), Cervix Length, Left/Right Ovarian Artery, Left/Right Uterine Artery, Uterine Wall Thickness, Vessels, Pelvic Floor, Ovarian Cyst (left/right), Ovarian Mass (left/right), Adnexal Cyst (left/right), Generic Cyst, Adnexal Mass (left/right), Generic Mass, Generic Lesion, Bladder (Length/Width/Height/Vol), Internal Midline Indentation, Angle of Indentation of Fundus, FHR, IOTA LR2 Model (Ovary Measurement diagnostic tool), IOTA Simple Rules (Ovary Measurement diagnostic tool), IOTA ADNEX Model (Ovary Measurement diagnostic tool), Myoma all included in Summary Reports	
Pediatrics:	Left/Right Hip Joint; Pericallosal Artery, included in Summary Report	
Cephalic:	Left/Right ACA (Anterior Cerebral Artery), Left/Right MCA (Middle Cerebral Artery), Left/Right PCA (Posterior Cerebral Artery), Basilar Artery, A-Com. A (Anterior Com. Artery), P-Com. A (Posterior Com. Artery), Left/Right CCA (Common Carotid Artery), Left/Right ICA (Internal Carotid Artery), Left/Right Vertebral Artery, Vessels; all included in Summary Reports	
MSK:	none	

13.11.3 OB Tables

"Age tables":

AC	ASUM, CFEF, Hadlock_82, Hadlock_84, Hansmann, Hobbins, Intergrowth, Jeanty, JSUM, Kurmanavicius, Merz, Nicolaides, Shinozuka, Siriraj, Tokyo, WHO
AD	Persson
APAD	Merz
APTD	Hansmann
APTDxTTD	Shinozuka, Tokyo
BOD	Jeanty
BPD	ASUM, ASUM (old), Campbell, CFEF, Chitty (outer-outer) (outer-inner), Eik-Nes, Hadlock_82, Hadlock_84, Hansmann, Hobbins, Intergrowth, Jeanty, Johnsen, JSUM, Kurmanavicius, Kurtz, Leung, McLennan, Merz, Nicolaides, OSAKA, Persson, Rempen, Sabbagha, Shinozuka, Siriraj, Tokyo, UltraARG, Verburg, WHO
CEREB	Chitty, Goldstein, HILL, Hobbins, Nicolaides, Verburg
CLAV	YARKONI
CRL	ASUM, DAYA, Eik-Nes, Hadlock, Hansmann, Intergrowth, JSUM, McLennan, Persson, Pexters, Nelson, OSAKA, Rempen, Robinson, Robinson_BMUS, Sahota, Shinozuka, Tokyo, Verburg
FL	ASUM, CFEF, Chitty, Eik-Nes, Hadlock_82, Hadlock_84, Hansmann, Hobbins, Hohler, Intergrowth, Jeanty, Johnsen, JSUM, Kurmanavicius, Leung, Persson, Merz, Nicolaides, O'Brien, OSAKA, Shinozuka, Siriraj, Tokyo, UltraARG, WARDA, WHO
FTA	OSAKA
FIB	Jeanty
GS	Hansmann, Hellman, Holländer, Nyberg, Rempen, Tokyo
HC	ASUM, CFEF, Chitty, Hadlock_82, Hadlock_84, Hansmann, Intergrowth, Jeanty, Kurmanavicius, Leung, Merz, Nicolaides, Siriraj, Johnsen, WHO
HL	ASUM, Hobbins, Jeanty, Merz, OSAKA
LV	Tokyo
MAD	Eik-Nes, eSnurra, Kurmanavicius
OFD	ASUM, Chitty, Hansmann, Jeanty, Kurmanavicius, Merz, Nicolaides
RAD	Jeanty, Merz
TCD	Chavez
TIB	Jeanty, Merz
TAD	CFEF, Merz
TTD	Hansmann
ULNA	Jeanty, Merz

"Growth tables":

AC	ASUM, CFEF, Chitty, Hadlock, Hadlock82, Hansmann, Jacot-Guillarmod, Jeanty, Johnsen, JSUM, Kurmanavicius, Lai_Yeo, Lessoway, Leung, Merz, Nicolaides, Paladini, Shinozuka, Siriraj, Stork, Tokyo, Verburg, Medvedev, Intergrowth, WHO
AD	Persson
AFI	Moore
AORTA VMAX	Rizzo

Aolst ED	DelRio2006
Aolst PI	DelRio2006
Aolst RI	DelRio2006
Aolst PS	DelRio2006
Aolst TAmx	DelRio2006
APAD	Merz
APTD	Hansmann
APTDxTTD	Shinozuka_SD
AxT	Shinozuka, Tokyo
BOD	Jeanty
BPD	ASUM, Campbell, CFEF, Chitty, Eik-Nes, Hadlock, Hadlock82, Hansmann, Jacot-Guillarmod, Jeanty, JSUM, Kurmanavicius, Lai_Yeo, Lessoway, Leung, McLennan, Merz, Nicolaides, Paladini, Persson, OSAKA, Sabbagha, Shinozuka, Siriraj, Stork, Tokyo, Verburg, Medvedev, Intergrowth, WHO
CLAV	Yarkoni
CM	Nicolaides
CRL	ASUM, Hadlock, Hansmann, Intergrowth, JSUM, McLennan, Persson, OSAKA, Robinson, Robinson 1993, Shinozuka, Tokyo, Pexters, Medvevev
DV a/S	JSUM
DV PI	Baschat, JSUM
DV PLI:	Baschat
DV PVIV	Baschat
DV S/a	Baschat
FIB	Chitty, Jeanty, JFFSD, Siriraj
FL	ASUM, CFEF, Chitty, Eik-Nes, Hadlock, Hadlock82, Hansmann, Jacot-Guillarmod, Jeanty, Johnsen, JSUM, Kurmanavicius, Lai_Yeo, Lessoway, Leung, Merz, Nicolaides, O'Brien, OSAKA, Paladini, Persson, Shinozuka, Siriraj, Stork, Tokyo, Verburg, WARDA, Medvedev, Intergrowth, WHO
FWg	Alexander
FOOT	Chitty
FTA	Osaka
GS	Hellman, Nyberg, Rempen, Tokyo
HC	ASUM, CFEF, Chervernak, Chitty, Hadlock, Hadlock82, Hansmann, Jacot-Guillarmod, Jeanty, Johnsen, Kurmanavicius, Lai_Yeo, Lessoway, Leung, Merz, Nicolaides, Paladini, Siriraj, Stork, Verburg, Medvedev, Intergrowth, WHO
HL	ASUM, Chitty, Jeanty, Lai_Yeo, Merz, JFFSD, OSAKA, Paladini, Siriraj, Medvedev
IFA	Rotten
IVC PLI	JSUM
Kidney L	Chitty(2003), Vuuren
Kidney W	Chitty(2003), Vuuren
Kidney H	Chitty(2003), Vuuren
Kidney Vol	Chitty(2003)
Kidney RPAP	Chitty(2003), Vuuren, Romero, Hansmann
Lung Area Left/Right	Peralta
Lt.Tei (ICT,IRT), Lt.Tei (a,b)	Bhorat

LV	Tokyo
MAD	EIK-NES, eSnurra, Kurmanavicius
MainPA Vmax	Rizzo
MCA CP	Ebbing
MCA PI	Bahlmann, Ebbing JSUM
MCA RI	Bahlmann, JSUM
MCA PV	Mari
MCA PS	Schaffer
MCA TAmx	Schaffer
MNM Ang.	deJong-Pleij
MV E/A	HARADA
NBL	BUNDUKI, SONEK, Medvedev, Orlandi
NT	Nicolaides
OFD	ASUM, Chitty, Hansmann, Jeanty, Kurmanavicius, Merz, Nicolaides, Medvedev, Intergrowth
RAD	Chitty, Jeanty, JFFSD, Merz, Paladini, Siriraj
SAG. AP	Malinger
SAG. CC	Malinger
Stomach APD	Goldstein
Stomach LD	Goldstein
Stomach TD	Goldstein
TAD	CFEF, JACOT-GUILLARMOD, Merz,
TC	Chitkara
TCD	Chavez, Goldstein, Hill, Jacot-Guillarmod, Nicolaides, Verburg
Thym. Dia.	Pittyanont
Thyr. Circ	Ranzini
ThyTh	Karl
TIB	Chitty, Jeanty, JFFSD, Merz, Paladini, Siriraj
TTD	Hansmann
TV E/A	HARADA
ULNA	Chitty, Jeanty, JFFSD, Merz, Paladini, Siriraj
UmbArt PI	Ebbing, JSUM, Merz, Schaffer, Drukker
UmbArt RI	JSUM, Merz, Kurmanavicius, Schaffer, Drukker
UtArt PI	Gomez, Merz, Schaffer
UtArtRI	Merz, Schaffer
UmbArt S/D	Drukker
Vermis A	Malinger
Vermis C	Malinger
Fractional Limb Avol/ Tvol	Lee

"Fetal Weight Estimation (EFW)":

AC	Campbell
AC, BPD	Hadlock
AC, FL	Hadlock 1
BPD, AC, FL	Hadlock 2
HC, AC, FL	Hadlock 3
BPD, HC, AC, FL	Hadlock 4
BPD, TTD	Hansmann
Avol	Lee
AC, Avol	Lee
AC, BPD, Avol	Lee
Tvol	Lee
AC, Tvol	Lee
AC, BPD, Tvol	Lee
AC, BPD	Merz
BPD, FTA, FL	Osaka
BPD, MAD, FL	Persson 1
BPD, MAD	Persson 2
HC, AC, FL	Schild
AC, BPD	Shepard
BPD, APTD, TTD, FL	Shinozuka 1
BPD, FL, AC	Shinozuka 2
BPD, APTD, TTD, LV)	Shinozuka 3
BPD, APTD, TTD, FL	Tokyo
HC, AC	Intergrowth

Gestational Age by EFW

Hadlock, JSUM 2001, Osaka, Shinozuka, Tokyo, WHO (-/m/f), Intergrowth, CFEF

Fetal Weight Growth FWg

Alexander, Ananth Tw (M,D), Bourgogne, Brenner, Burgundy (m/f), CFEF, Doubilet, Duryea (M/f), Ego (-/m/f), Eik-Nes, Hadlock, Hansmann, Hansmann (86), Hobbins/Persutte, Intergrowth, Johnsen (-/m/f), JSUM (2001), Kramer (m/f), Persson (96, 98), Osaka, Shinozuka, Tokyo, Williams, WHO (-/m/f), Yarkoni
--

Fetal Ratios

CC/TC	
CI (BPD/OFD)	Hadlock
FL/AC	Hadlock
FL/BPD	Hohler
FL/HC	Hadlock, WHO
HC/AC	Campbell

Va/Hem	Nicolaides, Hansmann
Vp/Hem	Nicolaides
LHR	Peralta
LTR (Lung Area/ Thorax Area)	Hasegawa
CVR	Peranteau
TT	Karl
AOI/DUCTART	DelRio
MD/MX	Rotten
Lt./Rt. Opht.Art	

13.12 External Inputs and Outputs

13.12.1 User Connectivity (direct access)

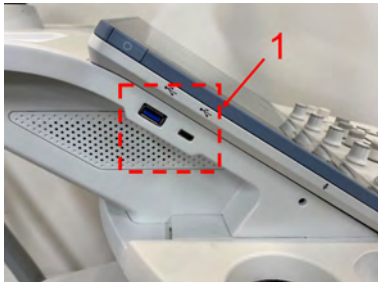
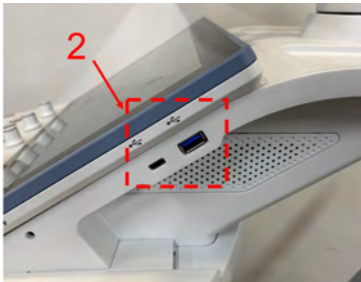
VGA out:	Standard SXGA at 60Hz
Network (RJ45):	1x Ethernet 1.0Gbps/100Mbps/10Mbps, IEC802-2, IEC802-3; built-in galvanic isolation according to IEC 60601 (i.e. 1500 V AC)
USB:	<p>Left side: USB 3.0 C type x1 and USB 3.0 A type x1</p> <p>Right side: USB 3.0 C type x1 and USB 3.0 A type x1</p> <div style="display: flex; justify-content: space-around; align-items: center;">   </div> <p style="text-align: center;"><i>Figure 13-2 Left side: USB 3.0 x 2 / Right side: USB 3.0 x 2</i></p>
S-Video out	<ul style="list-style-type: none"> • Video norm: PAL/NTSC (depending on system setup) • 1 x Mini DIN for OUT • Standard S-Video
HDMI	Standard FHD at 60Hz



In the console's standby mode, USB Type A ports located on left and right side can supply 5V/1A and this power is only for Vscan Air Probe Charger. Do not charge a mobile phone or any other device through USB Type A port in console's standby mode and the Vscan Air probe charger as well.

13.12.2 Connectivity behind rear cover (accessible after opening)

USB 3.0:	Rear panel of trolley unit: 2x
----------	--------------------------------

13.12.3 Peripherals

Display port Out	Standard Display port at 60Hz
VGA Out	Standard SXGA at 60Hz
Composite Out	Standard Composite at 60Hz
S-Video Out	Standard S-Video
Line Out	
Network	1x Ethernet 1.0Gbps/100Mbps/10Mbps, IEC802-2, IEC802-3; Built-in galvanic isolation according to IEC 60601 (i.e. 1500VAC)
USB-A	USB 3.0: Rear panel of trolley unit: 2x
HDMI	Standard FHD at 60Hz

13.12.4 ECG preamplifier

Patient cable:	Push-button electrode connections, 3 electrodes Cable types: <ul style="list-style-type: none"> ● NORAV, Code C3-C-E-ODU
Defibrillator Protection	Protected against 360 J discharge
Defibrillation recovery time	< 5 sec.
Frequency range (-3db):	0.5 - 150 Hz
Full scale range	+/- 5 mV
Sample Rate	1000/ s
Communication	USB 2.0, Full Speed, Isochronous Transfer Type
Ambient temperature:	Details see 1.1.16
Dimensions (L/W/H)	87/45/22 mm (L/W/H)

13.13 Deep Learning Based Features

Note *Some of these deep learning based features are not available in all countries:*

- SonoLystIR
- SonoLystX
- SonoLystlive
- SonoPelvicFloor 2.0
- SonoCNS
- SonoBiometry Cereb, Vp, CM
- FetalHS
- SonoAVC™follicle Auto Caliper
- Fibroid Mapping

The application of deep learning based features requires caution by the user and an informed decision on the usage of the specific feature. Therefore, all caution information and performance testing for each feature are summarized in this chapter.

Note *All cautions mentioned below supplement the cautions from previous chapters.*

SonoLystIR



Caution

SonoLystIR facilitates the selection of images. It must be used with extreme care. The selection of results is a suggestion of the system. The user is responsible for the selection of images.



Caution

SonoLystIR should be used during second trimester (18-24 weeks) ultrasound scans of normal singleton fetuses.

Performance Testing for SonoLyst:

Sub-Feature	Minimum Acceptable Algorithmic Performance	Number of Test Images
SonoLystIR	80% accuracy	41936

SonoLystX



Caution

SonoLystX facilitates the identification of criteria in images and must be used with extreme care. The identification results are a suggestion of the system. The user is responsible for the identification results.



Caution

SonoLystX should be used during second trimester (18-24 weeks) ultrasound scans of normal singleton fetuses.

Performance Testing for SonoLystX:

Sub-Feature	Minimum Acceptable Algorithmic Performance	Number of Test Images
SonoLystX	80%	9998

SonoLystlive



Caution

SonoLystlive facilitates the identification of criteria in images and must be used with extreme care. The identification results are a suggestion of the system. The user is responsible for the identification results.



Caution

SonoLystlive should be used during second trimester (18-24 weeks) ultrasound scans of normal singleton fetuses.



Caution

SonoLystlive facilitates the automatic storage of images based on identification of predefined criteria. The stored images are a suggestion of the system. Images, which were not actively accepted the user, are marked with an informational text and a corresponding warning symbol.

Performance Testing for SonoLystlive:

Sub-Feature	Minimum Acceptable Algorithmic Performance	Number of Test Images
SonoLystlive	80% accuracy	5623

SonoPelvicFloor 2.0



Caution

SonoPelvicFloor 2.0 facilitates the measurement of the levator hiatus and must be used with extreme care. The measurement results are a suggestion of the system, if in doubt verify with manual measurement methods. The user is responsible for the diagnostic interpretation of the measurement results.



Caution

SonoPelvicFloor 2.0 facilitates the selection of planes. It must be used with extreme care. The selection of results is a suggestion of the system. The user is responsible for the selection of images.

Performance Testing for SonoPelvicFloor 2.0 :

Sub-Feature	Minimum Acceptable Algorithmic Performance	Number of Test Images
Plane Alignment	70% for good quality Volumes 60% for challenging quality Volumes	110 3D/4D Volumes
Levator Hiatus Measurement	70% for good quality Volumes 60% for challenging quality Volumes	110 3D/4D Volumes
Plane Tracking	70% for good quality volumes 60% for challenging quality volumes	94 4D datasets

SonoCNS



Caution

SonoCNS facilitates the measurement of fetal brain structures and must be used with extreme care. The measurement results are a suggestion of the system, if in doubt verify with manual measurement methods. The user is responsible for the diagnostic interpretation of the measurement results.



Caution

SonoCNS facilitates the selection of planes. It must be used with extreme care. The selection of results is a suggestion of the system. The user is responsible for the selection of images.



Caution

SonoCNS is intended for use with gestational ages between 18 and 25 weeks only.

Performance Testing for SonoCNS:

Sub-Feature	Minimum Acceptable Algorithmic Performance	Number of Test Images
TTP	80% for good quality Volumes 60% for challenging quality Volumes	183 volumes
TVP	80% for good quality Volumes 60% for challenging quality Volumes	183 volumes
TCP	80% for good quality Volumes 60% for challenging quality Volumes	183 volumes
Cereb	80% for good quality Volumes 60% for challenging quality Volumes	183 volumes
CM	80% for good quality Volumes 60% for challenging quality Volumes	183 volumes
Vp	80% for good quality Volumes 60% for challenging quality Volumes	183 volumes

SonoBiometry Cereb, CM, Vp



Caution

SonoBiometry Cereb, CM, Vp facilitates the measurement of fetal brain structures and must be used with extreme care. The measurement results are a suggestion of the system, if in doubt verify with manual measurement methods. The user is responsible for the diagnostic interpretation of the measurement results.



Caution

SonoBiometry Cereb, CM, Vp is intended for use with gestational ages between 18 and 25 weeks only.

Performance Testing for SonoBiometryBrain:

Sub-Feature	Minimum Acceptable Algorithmic Performance	Number of Test Images
Cereb	80% for good quality Volumes 60% for challenging quality Volumes	85 datasets (2D/3D)
CM	80% for good quality Volumes 60% for challenging quality Volumes	85 datasets (2D/3D)
Vp	80% for good quality Volumes 60% for challenging quality Volumes	97 datasets (2D/3D)

fetalHS



Caution

fetalHS facilitates the measurement of fetal heart structures and must be used with extreme care. The measurement results are a suggestion of the system, if in doubt verify with manual measurement methods. The user is responsible for the diagnostic interpretation of the measurement results.



Caution

fetalHS facilitates the selection of images. It must be used with extreme care. The selection of results is a suggestion of the system. The user is responsible for the selection of images.



Caution

fetalHS is intended for use with gestational ages between 18 and 25 weeks only.

Performance Testing for *fetalHS*:

Sub-Feature	Minimum Acceptable Algorithmic Performance	Number of Test Images
4CH view detection: True positives	70%	140
4CH view detection: True negatives	70%	103
4CH view detection: Combination of true positives and true negatives	80%	143
3VT view detection: True positives	70%	100
3VT view detection: True negatives	70%	100
3VT view detection: Combination of true positives and true negatives	80%	200
Heart angle meas.	80%	246

SonoAVC™follicle Auto Caliper



Caution

SonoAVC™*follicle* Auto Caliper facilitates the measurement of the follicle's 2D diameters and must be used with extreme care. The measurement results are a suggestion of the system, if in doubt verify with manual measurement methods. The user is responsible for the diagnostic interpretation of the measurement results.

Sub-Feature	Minimum Acceptable Algorithmic Performance	Number of Test Images
Auto Caliper	70%	67 2D/3D datasets

SonoGYN - Fibroid Mapping



Caution

Fibroid Mapping facilitates measurements of the uterus, endometrium, and fibroids and must be used with extreme care. The measurement results are a suggestion of the system, if in doubt verify with manual measurement methods. The user is responsible for the diagnostic interpretation of the measurement results.



Caution

Fibroid Mapping facilitates 3D segmentation and visualization of the uterus, endometrium, and fibroids and must be used with extreme care. The size and location of the anatomical objects are a suggestion of the system, if in doubt verify with manual visualization based on the ultrasound volume. The user is responsible for the diagnostic interpretation of the visualization results.

Sub-Feature	Minimum Acceptable Algorithmic Performance	Number of Test Images
Uterus segmentation	70%	70 3D Volumes
Endometrium segmentation	70%	70 3D Volumes
Fibroid segmentation	70%	70 Fibroid instances

Chapter 14

Glossary - Abbreviations

Description of abbreviations, sorted alphabetically

A

Abbreviation	Designation
A2C Dias.	2 chamber Diastole
A2C Syst.	2 chamber Systole
% StA	Area Reduction in%
% StD	Distance Reduction in%
A-Com. A	Anterior communicating artery
Aborta	Number of abortions
AC	Abdominal Circumference
ACA	Anterior Cerebral Artery
ACC	Acceleration
AD	Abdominal diameter
AFI	Amniotic Fluid Index
ANT TIB A	Anterior Tibial Artery
ANT TIB V	Anterior Tibial Vein
Ao Cusp	Aortic Valve Cusp Separation
Ao Root Ampl	Aortic Root Amplitude
Ao Root Diam	Aortic Root Diameter
Aorta Vmax	Maximum Flow Velocity Aorta
Ao/LA	Aorta/Left Atrium
AV	Aortic Valve
APAD	Anterior/Posterior Abdominal Diameter
APTD	Anterior/Posterior Thoracic Diameter
APTDxTTD	APTD x Trunc Transverse Diameter
ARC A	Arcuate Artery (Renal Vascular Measurement)
ASUM	Australian Society for Ultrasound in Medicine
AUA	Average Ultrasound Age
AVA	Aortic Valve Area
A Vol	Arm volume
AXILL	lat. Axilla
AXILL A	Axillary Artery

B

Abbreviation	Designation
BASIL	lat. Basilaris
Basilaris	Basilar engl. = lat. Basilaris
Basilar	lat. Basilaris
B-Flow	B-Flow
BOD	Binocular Distance
BPD	Biparietal Diameter

Abbreviation	Designation
BRACH	lat. Brachialis
BRACH A	Brachial Artery
BSA	Body Surface Area
Bulb	lat. Bulbus = engl carotid (artery) bulb

C

Abbreviation	Designation
CCA	Common Carotid Artery
CEPH	lat. Cephalica = engl. Cephalic
Cereb	Cerebellum
CFEF	Collège Français d'Echographie Foetale
CFM	Color Flow Mode
CGA	Calculated Gestational Age
CI	Cephalic Index
CLAV	Clavicle
CM	Cisterna Magna
CPR	Ebbing
CO	Cardiac Output
COM FEM A	Common femoral artery
COM FEM	common femoral
COM ILIAC A	Common iliac artery
COM ILIAC V	Common iliac vein
CRL	Crown-Rump Length
CSA	Cross sectional area
C.S.P	Cavum Septum Pellucidum
CUA	Composite Ultrasound Age
CW	Continuous Wave Doppler

D

Abbreviation	Designation
d	Diastole (diastolic)
DEC	Deceleration
DEEP FEM A	deep femoral artery
DEEP FEM V	deep femoral vein
Din	Inner (reduced) distance
Dout	Outer (original) distance
DOB	Day of Birth
DOC	Day of Conception
Dor. PenA	Dorsal Penile Artery

Abbreviation	Designation
DORS PED A	lat. arteria dorsalis pedis = engl. Dorsal pedis artery
Dur	Duration
DV PI	Ductus Venosus PI (=Pulsatility Index)
DV PLI	Ductus venosus PLI (=preload Index)
DV PVIV	Ductus venosus PVIV (=peak velocity index vein)
DV S/a	Ductus venosus S/a ratio

E

Abbreviation	Designation
ECA	External Carotid Artery
Ectopic	Number of ectopic pregnancies.
ED	End Diastole (see also: Vd)
EDD	Estimated Day of Delivery
EDV	End Diastolic Velocity
EF	Ejection Fraction
EFW	Estimated Fetal Weight
Endo Area	Endocardial Area
Epi Area	Epicardial Area
Epi Length	Epicardial Length
EPSS	E-Point-to-Septum Separation
ERO	Effective Regurgitant Orifice
EUM	Electronic Instructions for Use
Exp. Ovul.	Expected Ovulation
EXT ILIAC A	External iliac artery
EXT ILIAC V	External iliac vein

F

Abbreviation	Designation
FEM V	Femoral Vein
FHR	Fetal Heart Rate
FIB	Fibula Length
FL	Femur Length
FS	Fractional shortening
FTA	Fetal Trunk Area
FW	Fetal Weight

G

Abbreviation	Designation
GA	Gestational Age
Gmean	Mean Gradient
GP	Growth Percentile
Gpeak	Peak Gradient
Gravida	Number of pregnancies
GRAFT	vascular implant
GS	Gestational Sac
GSAPH V	Great saphenous vein

H

Abbreviation	Designation
HC	Head Circumference
HD-Flow™	High Definition Flow
HEM	Hemisphere
HI	Harmonic Imaging
HR	Heart Rate
HSV _a	Hemisphere Ventricle anterior
HSV _p	Hemisphere Ventricle posterior
HL	Humerus Length

I

Abbreviation	Designation
ICA	Internal Carotid Artery
IMT	Intima Media Thickness
INNOM A	innominate artery
INNOM V	innominate vein
INT ILIAC A	internal iliac artery
INTERLO A	Interlobular arteries
IOD	Inner Ocular Distance
IVRT	Isovolumetric Relaxation Time
IVS	Inter-ventricular Septum

J

Abbreviation	Designation
JSUM	Japan society of ultrasound in medicine
JUGUL	lat. Jugularis / engl. jugular

L

Abbreviation	Designation
LA Diam	Left Atrial Diameter
LEA	Lower extremity artery
LEV	Lower extremity vein
LMP	Last Menstrual Period
L SAPH V	lower saphenous vein
LV	Length of Vertebra
LV	Left Ventricle
LV Vol.	Left Ventricle Volume
LVA	Left Ventricular Area
LVD	Left Ventricle Diameter
LVM	Left Ventricular Mass
LVOT	Left Ventricle Outflow Tract
LVPW	Left Ventricle Posterior Wall

M

Abbreviation	Designation
M&A	Measurement & Analysis
MAD	Middle Abdominal Diameter
MainPA Vmax	Main pulmonary artery Vmax
MCA	Middle Cerebral Artery
MCA PI	Middle Cerebral Artery + Pulsatility Index
MCA PV	Middle Cerebral Artery + PV = PS peak systolic
MCFM	M Mode + Color Flow Mode
MCUB	median cubital
MD	"Mid" Diastole (minimum velocity)(see also: Vd and Vmin)
MI	Mechanical Index
MnG	Mean Pressure Gradient
M RENAL A	main renal artery
MPPS	Modality Performed Procedure Step
MV	Mitral Valve
MVA	Mitral Valve Area

N

Abbreviation	Designation
NBL	Nasal Bone Length
NF	Neck Fold
NT	Nuchal Translucency

O

Abbreviation	Designation
OFD	Occipito Frontal Diameter
OOD	Outer Ocular Distance
OTI	Optimized Tissue Imaging

P

Abbreviation	Designation
P-Com. A	Posterior Common Artery
Palm A	palmar artery
PAP	Pulmonary Artery Pressure
Para	Number of live births
PCA	Posterior Cerebral Artery
PERON A	peroneal artery
PERON V	peroneal vein
PD	Power Doppler
PG	Pressure Gradient
PHT	Pressure Half Time
PI	Pulsatility Index
PISA	Proximal Isovelocity Surface Area
PPSA	Predicted PSA (see also: PSA)
POPL A	popliteal artery
POPLIT V	popliteal vein
POST TIB A	posterior tibial artery
POST TIB V	posterior tibial vein
PRF	Pulse Repetition Frequency
PROF A	profunda femoris artery
PROF V	profunda femoris vein
PS	Peak Systole (see also: Vmax)
PSA	Prostate-specific antigen
PSV	Peak Systolic Velocity
PV	Pulmonary Valve
PVA	Pulmonary Valve Area
PW	Pulsed Wave Doppler

R

Abbreviation	Designation
RAD	Radius Length
RADIAL A	radial artery
Regurg	Regurgitation

Abbreviation	Designation
Renal	renal
RENAL A	renal artery
RENAL V	renal vein
RI	Resistivity Index
ROI	Region of Interest
RT	Real Time
RVD	Right Ventricle Diameter
RVOT	Right Ventricle Outflow Tract

S

Abbreviation	Designation
s	Systole (systolic)
S/D	Systolic/Diastolic Ratio
SD	Standard Deviation
SEGM A	segmental artery
SL	Spine Length
SRI	Speckle Reduction Imaging
STIC	Spatio-Temporal Image Correlation
SUBC A	subclavian artery
SUBC V	subclavian vein
Subclav	subclavian
SUP FEM A	superior femoral artery
SV	Stroke Volume

T

Abbreviation	Designation
TAD	Transverse Abdominal Diameter
TAm _{ax}	Time Averaged maximum velocity
TAm _{ean}	Time Averaged mean velocity
TCD	Transverse Cerebellar Diameter
TD	Tissue Doppler
ThTD	Thoracic transverse diameter
TI	Thermal Index
TIB	Tibia Length
TIB	Bone Thermal Index
TIC	Cranial Bone Thermal Index
TIS	Soft Tissue Thermal Index
TL Cine	Time Line Cine
TTD	Transverse Thoracic Diameter

Abbreviation	Designation
TUI	Tomographic Ultrasound Imaging
TV	Tricuspid Valve
TVA	Tricuspid Valve Area
TV E/A	tricuspidal valve E/A ratio
T Vol	Thigh Volume

U

Abbreviation	Designation
UEA	Upper extremity artery
UEV	Upper extremity vein
ULNA	Ulna Length
ULNAR	Ulnar
ULNAR A	ulnar artery
UmbArt PI	umbilical artery pulsatility index
UmbArt RI	umbilical artery resistance index

V

Abbreviation	Designation
Va/Hem	anterior horn of lateral ventricle / hemisphere
Verteb	Vertebral
VCI	Volume Contrast Imaging
Vd	Velocity diastolic (= minimum velocity or end-diastolic velocity) (see also: ED and MD)
Vmax	maximum Velocity (see also: PS)
Vmean	mean Velocity
Vmin	minimum Velocity (see also: MD)
Vert. A.	Vertebral Artery
Vp/Hem	posterior horn of lateral ventricle / hemisphere
Vp	posterior horn of lateral ventricle
VPD	Protodiastolic Velocity
VTD	Telediastolic Velocity
VTI	Velocity Time Integral

X

Abbreviation	Designation
CrossXBeam ^{CRi}	CrossBeam Compound Resolution Imaging
XTD-View	XTD-View (Extended View)

Y

Abbreviation	Designation
YS	Yolk Sac

GE Ultrasound Korea, Ltd.
9, Sunhwan-ro 214beon-gil, Jungwon-gu, Seongnam-si,
Gyeonggi-do, 13204
Republic of Korea
www.gehealthcare.com

