

Ref. : F 3240-EP.pas

Rev. : E

Date : 06/06/2014

Page : 1/1

FLANGED TYPE "Y" STRAINER PN16

F 3240-EP



APPLICATION

Waste water filtering systems.

GENERAL CHARACTERISTICS

Cast iron "Y" body, cast iron bonnet.
Dismountable stainless steel strainer.
Flanged ends PN 16.

CONSTRUCTION

7	4	Washer	Stainless steel 304	
6	4	Nut	Stainless steel 304	
5	1	Drain plug	Stainless steel 304	
4	1	Cover	Cast iron EN-GJL-250	DIN: GG25 ASTM: A48 class 40B BS: 1452 Grade 250
3	1	Gasket	EPDM CH	
2	1	Strainer	Stainless steel X5CrNi 18-10	DIN: X5CrNi18 10 ASTM: A 182 AISI 304 BS: 1449-2 304 S15
1	1	Body	Cast iron EN-GJL-250	DIN: GG25 ASTM: A48 class 40B BS: 1452 Grade 250
Pos.	Qty.	Description	Material	

DIMENSIONS

DN	L	H	H1	ØD	ØK	T°	n	ØM	ØP	Weight (kg)	Mesh (mm)
15	130	80	130	95	65	45°	4	14	Rp1/4	2.3	1
20	150	91	146	105	75	45°	4	14	Rp1/4	3.02	
25	160	105	175	115	85	45°	4	14	Rp1/2	3.59	
32	180	124	210	140	100	45°	4	19	Rp1/2	5.04	
40	200	110	175	150	110	45°	4	19	Rp1/2	6.30	
50	230	117	192	165	125	45°	4	19	Rp1/2	7.91	
65	290	142	232	185	145	45°	4	19	Rp1/2	11.5	1.3
80	310	163	265	200	160	22.5°	8	19	Rp1/2	14.3	
100	350	194	323	220	180	22.5°	8	19	Rp1/2	17.0	
125	400	248	402	250	210	22.5°	8	19	Rp1/2	26.9	
150	480	280	430	285	240	22.5°	8	23	Rp3/4	41.9	1.6
200	600	346	560	340	295	15°	12	23	Rp3/4	68	
250	730	433	715	405	355	15°	12	28	Rp3/4	112	
300	850	480	785	460	410	15°	12	28	Rp3/4	157	
350	980	650	1100	520	470	11.25°	16	28	Rp3/4	402	
400	1100	854	1420	580	525	11.25°	16	31	Rp3/4	633	

WORKING CONDITIONS

Maximum working pressure :16 bar
Maximum working temperature: 140°C

STANDARDS

Pressure test according to standards
EN 12266-1, DIN 3230, BS 5154 and ISO 5208 :
Body : 24 bar.

Face to face according to standards EN 558-1
serie 1 and DIN 3202/1 serie F1.
Flanges drilled according to EN 1092-2 PN16.

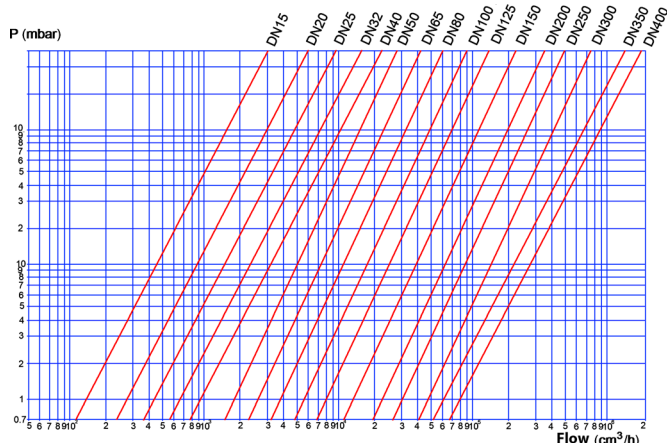
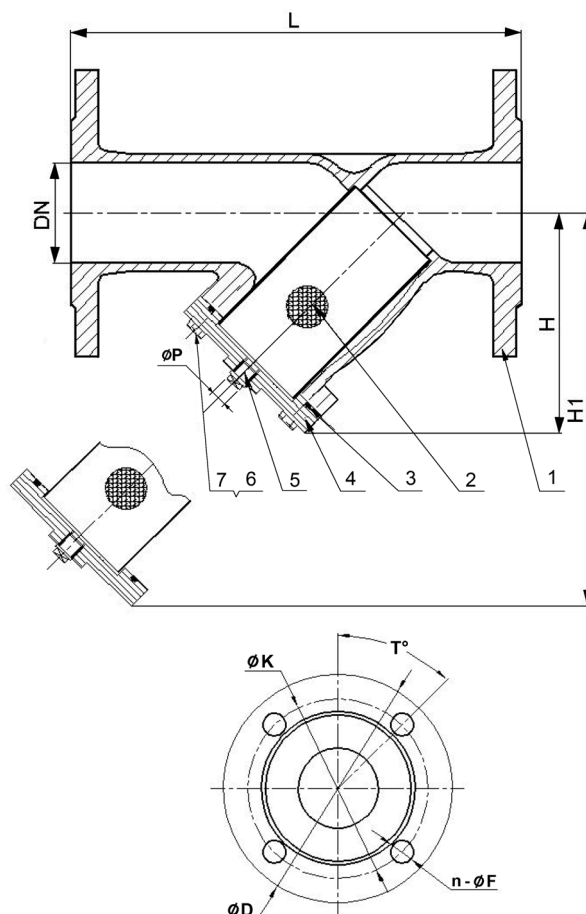

TECOFI France - 83, Rue Marcel Mérieux 69960 Corbas - FRANCE
Tél. +33 (0) 4 72 79 05 79 - Fax +33 (0) 4 78 90 19 19 / +33 (0) 4 72 79 05 70
Adresses e-mail : sales@tecofi.fr ; tecofi@tecofi.fr / Site web : www.tecofi.fr