

U3600 Series
Urinalysis Hybrid System

Operation Manual



This device bears the CE marking in accordance with the provisions of Directive 98/79/EC of the European Parliament and of the Council of 27 October 1998 on in vitro diagnostic medical devices and the Directive 2011/65/EU of the European Parliament and of the Council of 8 June 2011 on the restriction of the use of certain hazardous substances in electrical and electronic equipment.

The CE marking only applies to electrical equipment which has been placed on the market as per the EU Directive mentioned above.

Unauthorized changes to this product are not covered by the CE marking.

The Urinalysis Hybrid System is for in vitro diagnostic use.

Second edition (Dec., 2022)

© Copyright Zybio Inc., 2022. All rights reserved.

Intellectual property rights statement

The instrument and its incorporated software described in the Operation Manual are for *in vitro* diagnostic use only. Zybio Inc. (hereinafter referred to as Zybio) owns the copyright over the instrument information, scheme descriptions, and relevant graphics (hereinafter referred to as Information) in this manual and the intellectual property rights over the instrument(s) herein. The Information may be used if:

- The copyright notice appears on all copies;
- The Information is not modified;
- The Information is used as operating instructions or for informational purpose by Zybio authorized personnel; and
- Without Zybio's authorization or written permission, no graphics are used separate from the accompanying text of the manual.

Users of the Information shall assume full responsibility and all risks arising from illegal or illegitimate use of the Information. Zybio reserves the right to add, delete, or modify the Information at any time as part of ongoing instrument development without prior notification.

Disclaimers

All sample data in the manual (including but not limited to, the sample data in printouts, graphics, screens, etc.) are for reference only and shall not be used for clinical or maintenance evaluations. Data shown in printouts and screens do not reveal actual patient names or test results.

Labels depicted in the manual may appear different from actual labeling and are for reference only. Please take the actual labeling as the final.



Instrument users shall follow the operating instructions at any time. Zybio and its affiliates shall not be responsible for failures, errors, damages, losses, or other liabilities resulting from users' noncompliance with the procedures and precautions given herein.

In the event that any user should make any oral, written or electronic response to Zybio (such as feedback, questions, comments, suggestions, ideas, etc.), such response and any information submitted therewith shall be considered nonconfidential, and Zybio shall be free to reproduce, publish, or otherwise use such information for any purposes whatsoever including but not limited to, the research, development, manufacture, service, use, or sale of instruments incorporating such information.

Zybio is not engaged in providing medical advice or services.

Updates to the information may be provided in electronic form or paper. Always refer to the latest documents for the most current information.

Trademark statement

zybio,  and  zybio are the registered trademarks of Zybio Inc.;
Other trademarks referenced are property of their respective owners;
® and ™ are not specified in the manual.

Warranty statement

Zybio warrants the instrument against defects in materials and workmanship for a period of one year from the delivery date. If the instrument proves to be defective within the foregoing warranty period, Zybio, at its sole option, will repair, upgrade, replace the instrument or take other corrective measures.

The sales contract is your only warranty certificate and please keep it properly.

The free service is provided within the warranty period for the entire instrument, except for the consumables (Consumables refer to the disposable items that need to be replaced after each use or the fragile materials that need to be replaced regularly).

This warranty does not cover and is void with respect to the defects or malfunctions caused by:

- Accident, neglect, misuse, relocation, unauthorized repair or modification of the instrument, whether intentional or unintentional;
- Using non-approved parts, accessories, consumables, etc.;
- Installing instruments by the personnel not authorized by Zybio or its local distributor and/or not using the instrument according to instructions in this manual; and
- Force majeure, such as war, natural disaster, etc.

The limited warranty in this manual and the sales contract is the sole warranty provided by Zybio. No other warranties, express or implied, including warranties of merchantability or fitness for a particular purpose, are provided whatsoever.

In no event will Zybio be liable for any direct, indirect, consequential or incidental damages, including loss of profits and commercial opportunities, or for any claim by any third party, arising out of the use, the results of use or the inability to use this instrument.

If the warranty period and/or the warranty service described herein are conflict with the provisions of sales contract executed, the latter shall prevail.

For after-sales service, please contact the authorized local distributors or Zybio:

Zybio Inc.

Floor 1 to Floor 5, Building 30, No.6 of Taikang Road, Block C of Jianqiao Industrial Park,
Dadukou District, 400082 Chongqing, PEOPLE'S REPUBLIC OF CHINA

Tel: +86 (0) 23 6895 9999

Fax: +86 (0) 23 6869 9779

Web: <https://www.zybio.com>

E-mail: info@zybio.com

Revision history

Edition	Release date	Contents revised
01	May 24, 2022	First release
02	Dec. 12, 2022	Literal modification; Error correction.

Contents

<i>Intellectual property rights statement</i>	3
<i>Disclaimers</i>	3
<i>Trademark statement</i>	4
<i>Warranty statement</i>	5
1 General	1
1.1 Basic Information	1
1.2 Models	2
1.3 About the manual	3
1.4 Symbols	4
1.5 Electromagnetic compatibility (EMC)	7
1.6 Safety precautions	7
1.7 Residual risk	11
2 Installation	13
2.1 Installation requirements	13
2.1.1 Space requirements	13
2.1.2 Requirements for power supply.....	14
2.1.3 Environment requirements	14
2.1.4 Printer requirements	15
2.1.5 Handling requirements	15
2.2 System connection	15
2.2.1 Computer connection	15
2.2.2 Connecting the reagent.....	16
2.2.3 Installation of sensor.....	17
3 Instrument introduction	19
3.1 Structural compositions	19
3.1.1 Sample processing module	19
3.1.2 Optical counting cell module.....	19
3.1.3 Microscope camera module	19
3.1.4 Auto strip-pick module.....	19
3.1.5 Test strip transport module	19
3.1.6 Optical module	20
3.1.7 Fluidics module.....	20
3.1.8 Physicochemical module (optional).....	20
3.1.9 Circuit control module	20

Contents

3.1.10	Data processing module	20
3.1.11	Software	20
3.2	Appearance	20
3.2.1	Front view	20
3.2.2	Back view	21
3.2.3	Left side view	22
3.2.4	Right side view	22
3.3	Performance parameter.....	23
3.3.1	Main test items and indicators	23
3.3.2	Main performance parameters	27
3.4	Specifications and configuration.....	28
3.5	Software interface	30
4	Operation principles.....	33
4.1	Test principle of urine sediment.....	33
4.2	Test principle of strip.....	34
4.3	Test principle of turbidity.....	34
4.4	Test principle of color	35
4.5	Test principle of specific gravity.....	35
4.6	Test principle of conductivity.....	35
5	Daily operation.....	37
5.1	Preparations before test.....	37
5.1.1	Sample preparation.....	37
5.1.2	Prepare strips and desiccants	38
5.1.3	Test tube requirements.....	39
5.1.4	Barcode requirements.....	39
5.1.5	Inspection before startup	40
5.2	Sample test	40
5.2.1	Powering on.....	40
5.2.2	Login onto software	40
5.2.1	Confirmation of instrument status	41
5.2.2	Sample test.....	42
5.2.3	Emergency test	42
5.2.4	Modification of patient information	43
5.2.5	Confirmation of alarm information	44
5.3	Retest of sample	44
5.4	Test result.....	45

5.4.1	Browsing of various test images	45
5.4.2	Manual classification of images	46
5.4.3	Sediment size browsing	47
5.5	Result review	47
5.6	Query for test results.....	48
5.7	Preview and printing of report	48
5.8	Deletion of result.....	48
5.9	LIS Export.....	48
5.10	Erythrocyte phase prompt function	48
5.11	Sleep	49
5.12	Shut down	49
<i>6</i>	<i>Data query.....</i>	<i>51</i>
6.1	Query.....	51
6.1.1	Query by sample number	51
6.1.2	Query by barcode number	52
6.1.3	Query by patient's name	52
6.1.4	Query by department.....	52
6.1.5	Query by inspection time.....	52
6.2	Data query list	52
6.3	Clear historical data	53
6.4	Export of historical data	53
6.5	Preview and printing of reports	53
6.6	LIS export.....	53
<i>7</i>	<i>Focus.....</i>	<i>55</i>
7.1	Morphological focusing.....	55
<i>8</i>	<i>Calibrate.....</i>	<i>57</i>
8.1	Morphological calibration.....	57
8.2	Physicochemical unit calibration (optional unit).....	58
8.2.1	Specific gravity calibration	58
8.2.2	Turbidimeter calibration	59
8.2.3	Conductivity calibration	60
<i>9</i>	<i>Quality control.....</i>	<i>63</i>
9.1	Control	63
9.2	Quality control settings	63
9.3	Morphological quality control	64

Contents

9.3.1	Quality control registration.....	64
9.3.2	Morphological quality control testing	64
9.4	Dry chemical quality control	65
9.4.1	Quality control registration.....	65
9.4.2	Dry chemical quality control testing.....	66
9.5	Physicochemical unit quality control (optional unit).....	66
9.5.1	Quality control registration.....	66
9.5.2	Physicochemical unit quality control testing	67
9.6	Standard strip test.....	67
9.7	QC review	68
9.7.1	Morphological quality control query	68
9.7.2	Morphological quality control graph.....	68
9.7.3	Dry chemical quality control query.....	69
9.7.4	Dry chemical quality control graph	69
9.7.5	Printing	69
9.7.6	Physicochemical unit quality control query (optional unit).....	69
9.7.7	Physicochemical unit quality control graph (optional unit).....	70
9.7.8	LIS export.....	70
10	<i>Statistics.....</i>	<i>71</i>
11	<i>Management.....</i>	<i>73</i>
11.1	Reagent management.....	73
11.2	User management.....	73
11.3	Gender.....	74
11.4	Age unit	75
11.5	Race.....	75
11.6	Visit type.....	75
11.7	Charge type.....	76
11.8	Delivery department & doctor.....	77
11.8.1	Delivery department	77
11.8.2	Delivery doctor	77
11.9	Dilution ratio.....	78
11.10	Abnormal mark	78
12	<i>Settings.....</i>	<i>79</i>
12.1	System configuration	79
12.1.1	Set language.....	79

12.1.2	Set result decimal precision.....	79
12.1.3	Device setting.....	79
12.1.4	Device temperature alarm range	79
12.1.5	PHYC unit setting	79
12.1.6	Reagent expiration range prompt	79
12.1.7	Alarm.....	79
12.1.8	Test mode.....	80
12.1.9	Set manual review.....	80
12.1.10	Set sleeping time.....	80
12.1.11	Abnormal mark.....	80
12.1.12	LIS configuration	80
12.2	Morphological configuration	80
12.3	Dry Chemical Configuration	81
12.4	Re-examination rule.....	82
12.4.1	Microscopic examination condition	82
12.4.2	Urine culture conditions	82
12.5	Auto print	83
12.6	Auto send to LIS	84
12.7	Auto review	84
<i>13</i>	<i>Maintenance.....</i>	<i>85</i>
13.1	Replace sheath fluid	85
13.2	Prime sheath fluid	85
13.3	Gray.....	85
13.4	Empty.....	85
13.5	Clean flow pool	86
13.6	Clean fluidics.....	86
13.7	Clean physicochemical unit	86
13.8	Blank test.....	86
13.9	Clear data	87
13.10	Database backup and recovery	87
<i>14</i>	<i>Maintenance and care</i>	<i>89</i>
14.1	Clean the waste strip box	89
14.2	Clean the strip-transport plate	90
14.3	Clean waste liquid container	93
14.4	Clean the scanning window of the barcode scanner	93

Contents

14.5	Clean the sensor	93
14.6	Clean sheath fluid bottle	93
14.7	Empty fluidics.....	94
14.8	Check and replace the tubing	94
14.9	Replacement of wearing parts.....	94
14.10	Error information and troubleshooting.....	95
<i>Appendix A</i>	<i>Related information.....</i>	<i>117</i>
<i>Appendix B</i>	<i>Literature.....</i>	<i>119</i>

1 General

The Urinalysis Hybrid System provides basis for clinical diagnosis through the analysis, counting and analysis on physicochemical indicators of the sediment of human urine by using the flow image analysis technology and the principles of photoelectric colorimetry, refraction method and scattering method. It features accurate analysis and convenient operation. The instrument can provide optional physicochemical indicators if corresponding modules equipped, including: color, turbidity, specific gravity and conductivity.

The Urinalysis Hybrid System covers three models: U3600, U3601 and U3602. This manual is prepared mainly for U3600, and it also applies to U3601 and U3602.

This manual aims to help users understand the structure, working principle, function, performance, operation, sample analysis, maintenance, troubleshooting and technical support of the instrument.

In this chapter, the basic information, model, manual information, symbols, electromagnetic compatibility, precautions and warnings of the instrument are mainly introduced.

Note

- Please carefully read and understand the contents of this manual before using the instrument to ensure the correct use of the instrument and the personal safety of the operator.
- The pictures in this manual are only used for illustration or example, but not for other purposes. All pictures shown are for illustration purpose only. Actual product may vary due to product enhancement.
- This manual is provided together with the instrument. Please keep this manual properly after reading for reference at any time.



1.1 Basic Information

The basic information about the Urinalysis Hybrid System is provided in this section.

Table 1-1 Basic Information

Category	Details
Product name	Urinalysis Hybrid System
Model & REF No.	U3600: REF 02-15-04-0003-00 U3601: REF 02-15-04-0004-00 U3602: REF 02-15-04-0005-00
Structure components	The Urinalysis Hybrid System consists of a sample processing module, optical counting cell module, microscope camera module, automatic strip-pick module, strip transmission module, fluid pathway module, optical detection module,

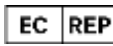
General

Category	Details
	data processing module, physicochemical module (optional), circuit control module and software.
Intended purpose	The Urinalysis Hybrid System is an automated instrument, intended for Semi-quantitative and qualitative in vitro determination of urine sediment, chemical constituents and optional physicochemical parameters of clinical urine specimens.
Intended users	Medical laboratory professionals or technicians, and trained medical doctors or nurses.
Intended use environment	Standardly managed laboratory
Overvoltage category	II
Pollution degree	2
Means of protection	Class I
Degree of ingress protection	IPX0
	Zybio Inc. Floor 1 to Floor 5, Building 30, No.6 of Taikang Road, Block C of Jianqiao Industrial Park, Dadukou District, 400082 Chongqing, PEOPLE'S REPUBLIC OF CHINA
	Lotus NL B.V. Koningin Julianaplein 10, 1e Verd, 2595AA, The Hague, Netherlands.
	See the instrument nameplate
Service life	8 year ¹
Contraindications	None

Note 1: the service life of the instrument is determined based on the lifespan test performed on the device. In the process of use, the user shall maintain or repair the instrument according to the Manual. The instrument with basic safety and performance after maintenance or repair can be used normally. In the process of use, the user shall maintain and repair the product according to the requirements of the user manual. After maintenance and repair within the validity period, the products with the basic safety and effectiveness confirmed can be used normally.

1.2 Models

The Urinalysis Hybrid System covers three models: U3600, U3601 and U3602. The operation, working principle, main functions, composition structure and key components of the three models of instruments are exactly the same and only different in the amount of data stored. Refer to the following table for the difference of various instrument models

Table 1-2 Model differences

Product model	Functional difference	Software name	Software model
U3600	500,000 pieces of data	Urinalysis Hybrid System software	U3600
U3601	100,000 pieces of data		U3601
U3602	300,000 pieces of data		U3602

1.3 About the manual

This manual is composed of 14 chapters and 2 appendices. Readers can find the correct chapters according to the information required.

Table 1-3 Manual guide



Chapters	Introduction
1. Introduction	Introduces the basic information, model, manual information, symbols, electromagnetic compatibility, safety precautions of the Urinalysis Hybrid System.
2. Installation	Introduces the installation requirements and precautions for use of the instrument.
3. Instrument introduction	Introduces the structural compositions, parameter and performance, specifications, configuration, and the software requirements and interface of instrument.
4. Analysis principle and calculation method	Introduces the test principle and calculation method of the instrument.
5. Daily operation	Introduces the process of daily sample running.
6. Data query	Introduces the methods of data query, such as test results.
7. Focus	Introduces the specific operation of daily focusing test.
8. Calibrate	Introduces the main contents and operation of calibration.
9. Quality control	Introduces the specific methods of daily standard test on control.
10. Statistics	Introduces the methods of workload, system log and maintenance record statistics.
11. Management	Introduces the operation and user settings of software.
12. Settings	Introduces the operation and system settings of software.
13. Maintenance	Introduces the common keys and operations in system maintenance.
14. Maintenance and care	Introduces the contents and methods of system maintenance and cleaning.
Appendix A Related information	Introduces the relevant information of the instrument, including the information on term explanation, list of accessories and reagent, cable information, training information, etc.
Appendix B Literature	The literature referenced is listed.

1.4 Symbols

The symbols used in the system and its manual are described in this section.



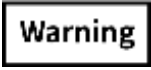

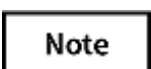

The symbols used in this manual are shown in the following table:















Table 1-4 Symbols used in the manual

Symbols	Explanation
	Indicates a reference to substances that may be hazardous to men, animals, plants, or the environment based on biological activity.
	Indicates a situation that, if not avoid, could result in hazards or other serious adverse consequences from the use of an IVD medical device.
	Indicates a potentially hazardous situation which, if not avoid, could result in minor or moderate injury, or damage of the IVD medical device or incorrect results.
	Indicates the important information or content that requires the attention of the operator.











The symbols used on the instrument and its package are shown in the following table:

Table 1-5 Summary of instrument and packaging symbols

Symbols	Meaning
	Indicates that there are potential biological risks associated with the medical device, necessary to consult instructions for use for details.
	Waste liquid is chemically corrosive, so wear protective gloves and protective eyewear if necessary during operation.
	Indicates the need for the user to consult the instructions for use for important cautionary information (white background).
	Indicates the need of taking care regarding the hazard specified by the supplementary sign; the user needs to consult the instructions for use (yellow background).
	Indicates the need of taking care to avoid injury from sharp elements.
	Indicates the need of taking care to avoid injury to hands when in the vicinity of equipment with closing mechanical parts.
	Indicates the need of taking care to avoid coming into contact with electricity.

Symbols	Meaning
	Indicates that this is a class-1 laser product, and laser radiation should be avoided.
	Indicates that unlocking is strictly prohibited for lay persons.
	Indicates the waste strip box.
	Warning for disassembly. No disassembly by non-professionals is allowed.
	Indicates the placement of test strip.
	Indicates the protective earth (ground).
	Indicates that the device is suitable for alternating current only.
	Indicates the manufacturer's serial number so that a specific medical device can be identified.
	Indicates the manufacturer's catalogue number so that the medical device can be identified.
	Indicates the manufacturer's batch code so that the batch or lot can be identified.
	Indicates the medical device manufacturer.
	Indicates the date when the medical device was manufactured.
	Indicates that this equipment is classified as Waste Electrical and Electronic Equipment under the European WEEE Directive. It must be recycled or disposed of in accordance with applicable local requirements.
	Indicates the instrument that is intended to be used as an in vitro diagnostic medical device.
	Indicates CE marking of conformity.

General

Symbols	Meaning
	Indicates a carrier that contains unique device identifier information.
	Indicates the need for the user to consult the instructions for use.
	Indicates the authorized representative in the European Community.
	Indicates the camera connection port.
	Indicates connection to the mains.
	Indicates disconnection from the mains.
T6.3AH250V	Indicates the fuse specification.
RS232	Indicates the serial port.
W2	Indicates the waste liquid outlet.
W-D	Indicates the waste liquid level sensor.
SW	Indicates the sheath fluid inlet.
SW-D	Indicates the sheath fluid level sensor.
	Indicates the maximum number of identical transport packages/items which may be stacked on the bottom package.
	Indicates that distribution packages shall not be rolled or turned over.
	Indicates that distribution packages shall be kept away from rain and be kept in dry conditions.
	Indicates the correct upright position of the distribution package for transport and/or storage.
	Indicates that contents of the distribution package are fragile therefore it shall be handled with care.

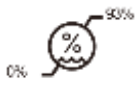
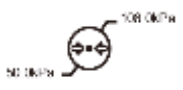
Symbols	Meaning
	The temperature to be maintained for the transport package
	The humidity range to be maintained for the transport package.
	The atmospheric pressure range to be maintained for the transport package.

1.5 Electromagnetic compatibility (EMC)

The Urinalysis Hybrid System complies with the emission and immunity requirements described in IEC 61326-2-6 and IEC 61326-1. It is not intended for use in residential environments and may not provide adequate protection to radio reception in such environments.

The instrument has been designed and tested to CISPR 11 Class A. In a domestic environment it may cause radio interference, in which case, you may need to take measures to mitigate the interference.

Do not use the instrument in close proximity to sources of strong electromagnetic radiation, as these may interfere with the proper operation. Use of the instrument in a dry environment, especially if synthetic materials are at present (synthetic clothing, carpets etc.) may cause damaging electrostatic discharges that may cause erroneous results.

1.6 Safety precautions

The special safety precautions for use of the Urinalysis Hybrid System are described in this section, so that the user can use the instrument safely and effectively. The following instructions should be followed strictly. Otherwise, inaccurate test results, instrument damage, personal injury, etc. may be caused.

Note

- The Urinalysis Hybrid System can only be operated and used by the personnel trained by Zybion or its distributors.
- The instrument should be correctly installed in the environment specified in this manual. For installation and use of the instrument in the conditions other than that specified, unreliable results and damage to the instrument may be led to. As for changing the working environment of the instrument, if required, please contact Zybion or its distributors.
- In the case that the label of the instrument is blurred or falls off, please contact Zybion for replacement.
- For incorrect analysis parameters will lead to wrong test results, please consult Zybion or its distributors.
- Before the test, carefully check the joints of each tubing for any liquid leakage, which will lead to inaccurate aspiration and dispensing capacity.
- Carefully check the reagents and samples before testing to ensure no insoluble floating matters, such as cellulose, fibrin and others. Otherwise, the sample probe will be blocked.
- Do not place reagents and samples on the top cover or workbench of the instrument to avoid liquid spilling and leakage.

General

- Some substances of the discarded instrument are subject to the pollution control regulations. Please follow the local regulations to handle the discarded instrument.
- Any serious incident that has occurred in relation to the instrument shall be reported to the manufacturer and the competent authority of the Member State in which the user and/or the patient is established.

System use

In order to use the Urinalysis Hybrid System more safely and effectively, please use according to the following regulations:

Warning

- The instrument should be used according to the relevant instructions in the manual. Improper use may lead to incorrect test results, or even system damage or personal injury.
- The protection provided by the instrument may be receded if it is not used in the manner prescribed by Zybio.
- Do not touch the rack-in module in operation to prevent scratching.
- Do not install any software and hardware other than those specified by Zybio in the system. Meanwhile, do not run other software during the system operation. Otherwise, the normal operation of the system may be hindered.
- Do not use this system for any other purposes. As the computer virus may spread through USB, program, network and other means, improper use may cause the instrument to be infected by the virus.
- Near the power interface of the instrument are two fuses (specification: **T6.3AH250V**). If either one is blown, please replace it timely.

Note

- During the first test of the instrument, focusing and calibration should be performed at first, followed by quality control, so as to confirm that the system works normally.
- For daily use of the system, it is recommended to perform daily focusing and quality control to ensure the reliability of the results.

System maintenance

The Urinalysis Hybrid System should be maintained according to the following regulations:

Warning

- Please maintain the system according to the relevant instructions in this manual. Improper maintenance may lead to incorrect test results, or even system damage or personal injury.
- The hospital or institution using this instrument must properly formulate and implement a set of acceptable repair/maintenance plan to avoid failure of the instrument or threatening the personal safety.
- After the main components, such as the physicochemical components, optical components and syringe components, are replaced, calibration analysis is required. The replacement and maintenance of all components shall be carried out by the after-sales engineer or agent designated by Zybio.

Note

- If the instrument is out of service due to failure or other reasons and maintenance or treatment is required, please contact Zybio or its distributors in time. Meanwhile, other measures, such as using other instruments or methods, should be taken to replace the unfinished test, so as to avoid the delay of the results.
- The surface of the instrument shall be wiped with a cloth wet with 75% ethanol or water every day. Do not use strong acid and strong alkaline cleaning agents, as they may cause a hazard as a result of a reaction with parts of the instrument or with material contained in it. If there is any doubt about the compatibility of decontamination or cleaning agents with parts of the instrument or with material contained in it, please contact Zybio or its authorized local distributor.

Sample

Prepare, store and use samples in strict accordance with the following regulations.

Note

- Please use a urine sample without any suspended solids. The suspended solids contained in the urine sample, if any, may lead to the blockage of the sample probe, which may further affect the accuracy of the test results. So, the operator should carefully observe the sample state.
- Store the samples correctly. Improper sample storage conditions may change the component content of the sample, thus affecting the accuracy of the test results.
- Do not leave the sample open for a long time to prevent the volatilization of sample. Otherwise, the accuracy of the test results may be affected.
- There might be interference factors in dry chemical tests, please refer to the instructions for use of the dry chemical reagents.
- The system has requirements for sample size of analysis. During sampling, the sample size should be determined properly according to the relevant instructions in this manual.
- Before analysis, it should be confirmed that the sample is placed at the correct place. Otherwise, the correct results cannot be obtained.

Reagent

The reagents should be stored and used in strict accordance with the following regulations.

Note

- For analysis with this system, the reagents produced by Zybio shall be used. Otherwise, the test results will be unreliable and the instrument may be damaged.
- For the use and storage of reagent, calibration solution and control, please refer to the reagent manual.
- Attention should be paid to the validity of supporting control and test strip. It is not allowed to use the expired control and test strip. The use of expired control or test strip will lead to the unreliable test results.
- The reagent, calibration solution and control, if stored improperly, even within the validity, may lead to failure to obtain correct test results.

General

- If the reagent lot number varies, focusing, calibration and analysis of quality control is required. Otherwise, the accuracy of test results may be affected.
- Before the continuous test, it is necessary to confirm that the reagent is sufficient and the connection interface is correct. Otherwise, no correct test results can be obtained.

Preventing electric shock

The Urinalysis Hybrid System meets the requirements on electrical safety in IEC 61010-1, IEC 61010-2-101. To prevent electric shock, the following regulations should be observed strictly:

Warning

- The power supply must be properly grounded. Otherwise, a risk of electric shock may be led to.
- The impedance between the protective earthing and each accessible part of the instrument shall be lower than 100 mΩ. Otherwise, unstable analysis result, electric leakage of the housing, and electric shock may occur due to poor grounding.
- Before the instrument is connected to the power cord, it must be ensured that the voltage and frequency of the AC power supply are as required by the instrument. The power must be off to connect the power cord.
- The unauthorized maintenance personnel shall not open the panel of the instrument when the power is on. Avoid spilling liquid on the workbench. If any liquid enters the instrument, turn off the power immediately and contact Zybio in time.
- In case of power failure, turn off the instrument immediately, and do not open the enclosure.
- Do not touch the power switch or the cord with wet hands.
- Do not unplug the power cord if the power is not cut off.
- Do not clean the instrument if the power is not cut off.
- Do not replace the fuse if the power is not cut off.
- This instrument complies with the IEC 61010-1 standards, and repeating any tests of this standard may damage the instrument and reduce protection against danger.

Laser safety

A laser product is contained in the instrument. In order to avoid laser injury to users, please read the following information carefully:

Warning

- The built-in barcode scanner CM600_L280 is a Class-1 laser product (according to IEC60825-1:2014, publication date 2014-05-15), which is used for the identification of sample barcode. The emitting wavelength is 650 nm (red), and the pulse duration is <120 μs. Users shall not disassemble the instrument under any circumstances. Otherwise, a risk of uncontrolled laser radiation may be resulted in.
- The external handheld barcode scanner is a LED red light product, which is mainly used to scan the barcode information of samples. Therefore, never look at the beam of scanner directly when the handheld barcode scanner is used.
- During the installation, commissioning and maintenance of the instrument, the warning information on the surface of the instrument should be read carefully, so as to avoid

the possible harmful laser radiation.

- The direct glare or reflection of laser rays should be avoided. Retinal injury may be caused in case of glaring at the laser rays with the naked eye for long time.

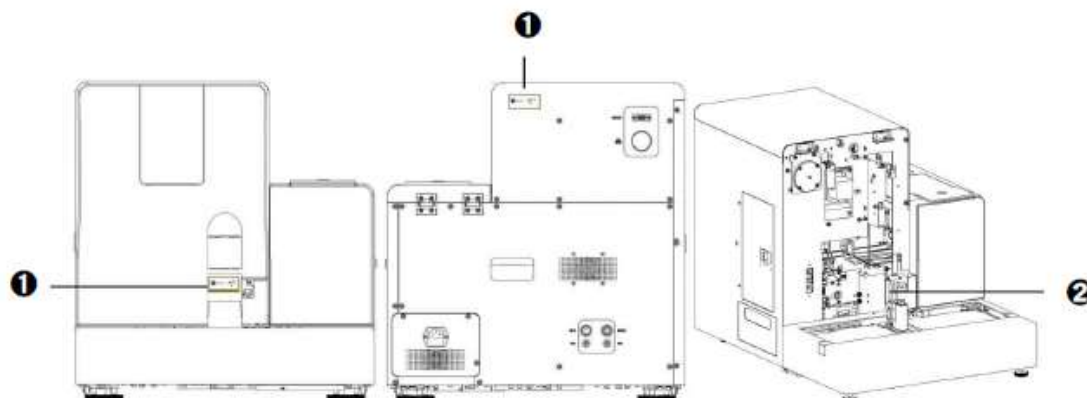



Figure 1-1 Laser label

No.	Part name	Description
1		It is affixed to the emergency baffle and the back of the instrument, reminding the user that there is class 1 laser radiation in these areas and do not look directly at the laser beam.
2	Laser window	It is located at the back of the emergency baffle and used to scan the sample barcodes.

Biological risk

The instrument operation and disposal of waste and scrapped instrument shall be performed in strict accordance with the following regulations.



- When using the instrument, operators should take preventive measures, such as wearing gloves, masks, protective glasses and overalls. Otherwise, infection may be caused due to contact with the contaminated areas and liquids, or skins may be damaged by contact with corrosive liquids. If the body contacts the contaminated or corrosive liquid accidentally, washing with water and immediate disinfection is required.
- The waste liquid, mainly containing the clinical urine samples, the used reagents and the sheath fluid, should be treated and discharged according to the discharge standard for biological risks.
- Users are required to complying with the relevant regional and national regulations on the discharge and treatment of reagents, waste liquid, waste samples, consumables, etc.
- When the instrument reaches its service life, it is recommended to stop using and dispose of it according to the requirements of the local environmental authority, but not to treat and discard as general waste.

1.7 Residual risk

General

The Urinalysis Hybrid System is a dedicated medical device, the safe and effective operation of the instrument requires the correct use of hardware and software system, as well as appropriate operating conditions.

The instrument shall be operated by persons obtained necessary trainings, and having a good knowledge of its intended use and the safety warnings and precautions for its usage.

Despite risk mitigation measures are implemented to minimize verities of hazards as far as possible, risks including but not limited to biological hazards, and electromagnetic compatibility cannot be completely excluded.

The instrument is used together with matched reagents as a detection system to provide test results of clinical samples. The reagents shall be chosen and used according to the instructions for use to ensure the accuracy of results.

2 Installation

The installation information of the instrument is mainly introduced herein, including the installation requirements, system connection, sensor installation and precautions for use, etc.

It is noted that the instrument should be strictly tested before delivery. In order to avoid impact during transportation, the instrument should be carefully packed before transportation. When the instrument arrives, the packaging should be carefully checked for any physical damage. In case of any damage, Zybio or its distributors should be notified immediately.

Warning

Unpacking and installation by personnel not authorized or trained by Zybio may cause personal injury or instrument damage. Do not unpack and install the instrument without the presence of authorized personnel of Zybio.

Note

- During transportation, the moving components are fixed with clamps/binding ties before shipment to avoid damage to the sampling components. Hence, the clamps/binding ties must be removed before using the instrument.
- After unpacking, the instrument should be carefully inspected visually and checked according to the attached packing list. In case of any damage caused during transportation or incomplete configuration, Zybio or its distributors should be notified immediately.

2.1 Installation requirements

Before installation, the operator must ensure that the following space, power supply, environment and fuse requirements are met preferably.

2.1.1 Space requirements

The instrument dimensions are: 687 mm (Length) × 512 mm (Width) × 530 mm (Height)

In order to provide space for repair and maintenance and to ensure the heat dissipation and normal operation of the instrument, the following conditions shall be satisfied during the installation of instrument:

- The workbench surface should be smooth (with an inclination less than 1/200);
 - The workbench can bear a weight of at least 150kg;
 - The distance from the left and right sides of the instrument to the wall shall not be less than 500 mm, and the distance to other instruments shall not be less than 1000 mm.
 - The distance from the back plate of the instrument to the wall shall not be less than 500 mm.
 - The distance from the front of the instrument to other instruments shall not be less than 1000 mm.
-

Installation

- Do not place the device in a position where it is difficult to operate the disconnecting device.
- The instrument should be installed according to the space requirements as shown in the figure below.

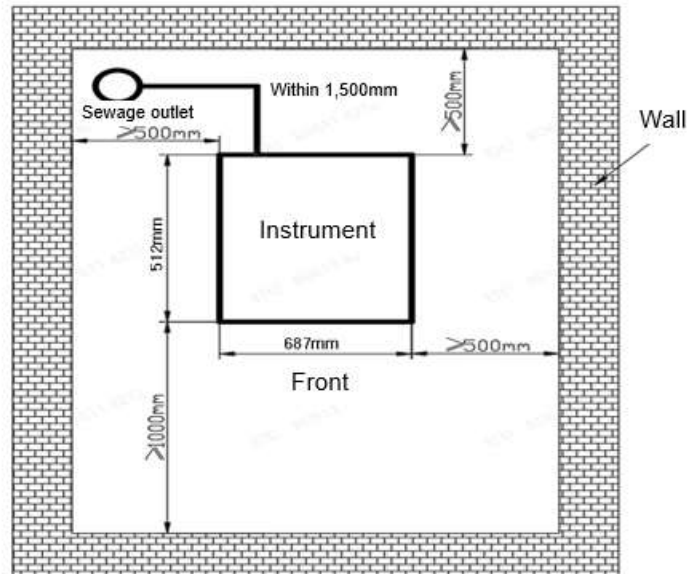

Figure 2-1 Space requirements for installation

2.1.2 Requirements for power supply

- 100 V - 240 V~, 50/60 Hz, with the main supply voltage fluctuation within $\pm 10\%$.
- The power socket shall be properly grounded, the voltage to ground shall be less than 5V, and the grounding resistance shall be less than 100 m Ω . If permitted, the instrument shall be connected to a special power cord.
- Input power: 150 VA. The hospitals are recommended to equip online UPS over 2000 VA.

Warning

- The instrument must be used under correct and good grounding conditions. Incorrect grounding may cause electric shock and instrument damage.
- The input voltage must meet the requirements of the instrument.

2.1.3 Environment requirements

The environmental requirements for instrument installation are mainly described herein.

- The environment should be as free as possible from dust, mechanical vibration, large noise source and power interference.
- It is recommended to evaluate the electromagnetic environment of the laboratory before the device is put into operation.
- The environment should be well ventilated, and ventilation equipment can be used, if necessary, but the direct air flow to the instrument should be avoided.
- Avoid direct sunlight or placement in front of heat source and wind source.
- Do not get close to the brushed motor, the flashing fluorescent lamp and the electrical contact devices that are normally on and off.

-
- No corrosive and combustible gas.
 - Indoor use.
-

Warning

The instrument cannot be used in the flammable and explosive environment.

Note

- If the room temperature is higher than the normal working temperature range of the instrument, the instrument temperature may be out of limit, and the test results will be unreliable.
 - If the instrument is in a dusty environment for a long time, the performance of the instrument may be degraded.
-

2.1.4 Printer requirements

The USB external printer is required to connect to the USB interface of the computer. For printer connection, please refer to the instructions for use of the related printer.

Note

Zybio does not provide printer, and users shall prepare the required printer.

2.1.5 Handling requirements

Never move the instrument installed and put into normal operation without authorization, so as to avoid vibration and damage to the high-precision components and wearing parts therein, which will affect the normal operation of the instrument.

To handle the instrument, if required, please contact Zybio or its distributors.

Warning

Never move the instrument without authorization. Otherwise, instrument failure or personal injury may be caused, for which Zybio will not undertake any liability.

2.2 System connection

The main information on system connection is described herein, including computer connection, reagent connection, sensor installation, and precautions during installation.

2.2.1 Computer connection

Refer to the following diagram to connect the computer with the instrument by a serial port cable and a network cable. Specifically, the network port is connected with that of the independent network card in computer, and the serial port is connected with that of the independent serial port card of the computer.

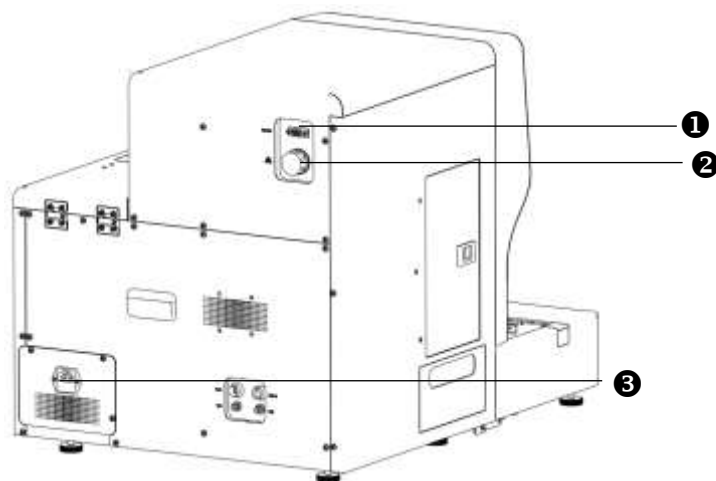

Figure 2-2 Electrical connection diagram

No.	Components
1	RS-232 interface
2	Network port
3	Power interface

2.2.2 Connecting the reagent

Please refer to the following diagram to connect the sheath fluid inlet pipeline and waste liquid tube of the instrument.

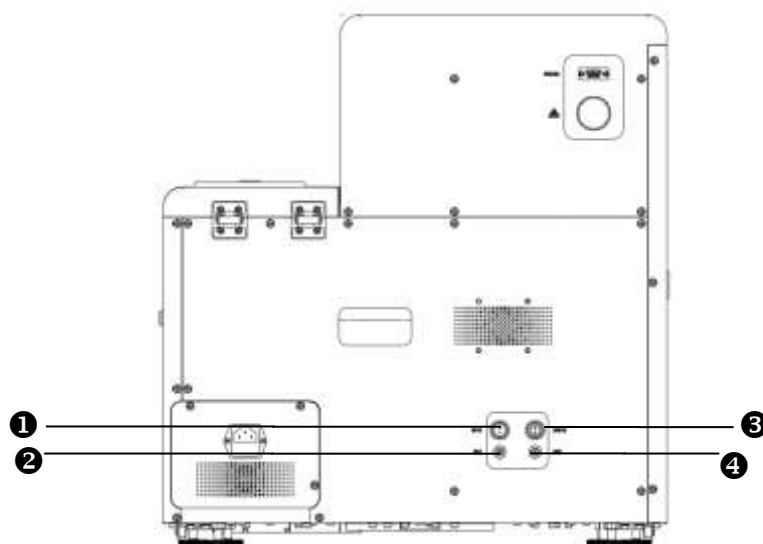

Figure 2-3 Reagent connection diagram

No.	Components
1	Waste liquid sensor
2	Waste liquid interface
3	Sheath fluid sensor
4	Sheath fluid interface



- Users are required to comply with the relevant regional and national regulations on the discharge and treatment of reagents, waste liquid, waste samples, consumables, etc.
- The reagents are irritant to eyes, skin and mucous membranes. Users exposed to the relevant articles in the laboratory should abide by the safe laboratory operation specifications and wear personal protective equipment (such as the protective clothing, gloves, masks, etc. for laboratory).

Caution

- The panel joint of the pipelines should be tightened, so that the whole pipeline is closed to prevent liquid leakage and seepage caused by siphon.
- The sheath fluid must be provided by Zybio or its distributors. Otherwise, the accuracy of the test results may be affected.

2.2.3 Installation of sensor

The installation of sensors is mainly introduced in this section, with the specific contents as follows:

- Installation of sheath fluid level sensor
- Press and open the circular cardboard with a dotted line for cutting on the upper side of the sheath fluid tank to expose the round hole.
- Pull up the container lid so that the cardboard around the round hole sticks to the container neck on the lower side of the lid to prevent it from sinking.
- Rotate to open the container lid (with the lid retained) and prohibit any foreign matter from entering the container.
- Install the sheath fluid level sensor in the accessory package. The sensor should be kept upright as far as possible during installation, and the container lid of the sheath fluid level sensor should be tightened.

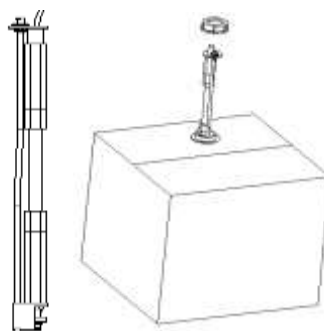

Figure 2-4 Installation of sheath fluid sensor

- Replacement of sheath fluid

Installation

The replacement process of sheath fluid is similar as the installation of sensor. The empty container and lid of sheath fluid should be reserved for backup.

Note

The shelf life of sheath fluid at room temperature is 30 days after being uncovered.

- Installation of waste liquid level sensor

Take a waste liquid container (with an empty container equipped in the packing box or replaced by an empty sheath fluid container. Pull the nozzle of the sheath fluid container out of the box for exposure), and open the lid. Install the waste liquid level sensor in the accessory package. During installation, the waste liquid sensor should be kept upright as far as possible, and the container lid of the sensor should be tightened to prevent the waste liquid from overflowing.

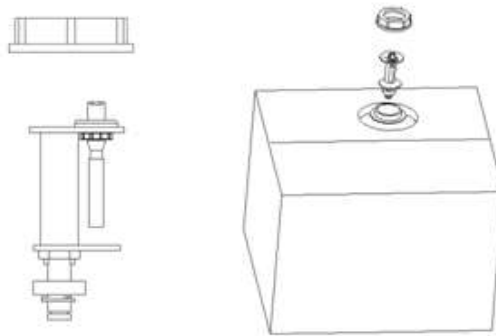

Figure 2-5 Installation of waste liquid level sensor

Note

- The liquid level sensor used in this device is only applicable to the waste liquid container provided by our Company or the waste liquid container of same specification and model (such as the sheath fluid container used by this instrument).
- For the connection of waste liquid tube, never fold or flatten the drain.



- Please make sure to wear gloves, masks, work clothes, and safety goggles during operation to prevent infection
 - The waste liquid, mainly containing **the clinical urine samples**, the used reagents and the sheath fluid, should be treated and discharged according to the discharge standard for biological risks.
-

3 Instrument introduction

The structure, parameter performance, specification, configuration, and the software requirements and interface of instrument are introduced in this chapter. It is noted that the graphics, settings or data in the illustration may not be completely consistent with the actual instrument due to different model and version.

3.1 Structural compositions

The instrument consists of a sample processing module, optical counting cell module, microscope camera module, auto strip-pick module, test strip transport module, fluidics module, optical module, data processing module, physicochemical module (optional), circuit control module and software.

3.1.1 Sample processing module

It is mainly composed of sample rack, rack-in assembly, and sample extraction assembly.

Rack-in assembly: its main function is to scan the sample barcode and transfer the sample to be tested, a single sample rack can hold 10 samples.

Sample aspiration assembly: it is designed to drive the sample probe to the aspiration position and cleaning position.

Fluidics assembly: with the pressurized gas and fluid as the medium, it is designed for fluid supply, sample mixing, sample aspiration, laminar flow in the flow cell, sample probe cleaning, and drainage of liquid waste, etc.

3.1.2 Optical counting cell module

It is mainly composed of a flow cell and a flow cell holder. After the instrument collects the sample, the sample to be tested and the sheath fluid entering the instrument are adjusted by the fluidics module and enter the flow cell at the preset flow rate and ratio. The sample forms a flat laminar flow in the flow cell, which is captured by the microscope camera module.

3.1.3 Microscope camera module

It is mainly composed of optical assemblies. Its function is to take a picture of the sample when the sample flows through the shooting area of the optical counting cell module, and transmit it to the data processing module.

3.1.4 Auto strip-pick module

It is mainly composed of strip-pick assemblies. Its function is to supply the test strips in the test strip chamber according to the specified quantity and direction.

3.1.5 Test strip transport module

It is mainly composed of the toothed plate, cam, bedplate, toothed plate fixing plate, vertical guide rail, limit shaft, rolling bearing, motor bracket, horizontal guide rail, connecting rod, fixed shaft and side plate. Its function is to transport the test strips selected by the strip-pick assembly to the sample dropping position and the test position according to the specified direction and time.

3.1.6 Optical module

The optical module is mainly composed of optical detector, LED, data acquisition board, support structure, guide rail, motor, synchronous belt, and zero-position optocoupler. The optical detector and LED are connected to the data acquisition board and fixed on the surface of the support structure. The motor drives the synchronous belt and the linear guide rail to drive the support structure to collect the information of the test strip at the test position of the test strip transport.

3.1.7 Fluidics module

The fluidics module is mainly composed of the syringe assembly, liquid storage assembly, cleaning assembly, pump, valves, pipeline and joints. It works on the principle that in a closed circuit (system), the pressurized gas and liquid are used as the media by the air pump, hydraulic pump and syringe to realize water replenishment, sample bubble mixing, sample extraction and sample cell cleaning, sample dropping, laminar flow in the flow cell, outer wall cleaning of sample probes, and liquid waste emptying during the transport of the device.

3.1.8 Physicochemical module (optional)

The physicochemical module is used to detect the color, turbidity, specific gravity, and conductivity of the samples. The sample color is obtained according to the R, G and B values; the specific gravity is obtained by testing the sample's ability to refract light; the conductivity value is obtained by testing the conductivity of the sample.

3.1.9 Circuit control module

It is mainly composed of the main control board, rack-in control board, and switching power supply. It is powered by the switching power supply, and the CAN bus realizes the communication between the modules.

3.1.10 Data processing module

The data processing module performs image segmentation on the sediment targets in the captured images, extracts the features of the target image in terms of morphology, statistics, frequency domain and texture, and normalizes these features as the input of the classifier for classification and calculation through the recognition algorithm of the data processing module. Finally, it is presented in the software interface through data transmission, and the user can audit it.

3.1.11 Software

The software has such functions as sample test, data query, focusing, calibration, quality control, statistics, system management, system maintenance, shutdown, and fault prompt. If the device is equipped with a physicochemical module, the software supports setting of the physicochemical module to test specific gravity, color, turbidity, and conductivity.

The software can perform operations such as sample application test, result query, online status check of test, focusing application test, calibration application test, quality control application test, device setting and maintenance.

3.2 Appearance

This section mainly introduces front view, back view, the left side view and the right side view of the instrument.

3.2.1 Front view

The structure and relevant important components on front of the instrument are introduced in this section. See the figure below for details:

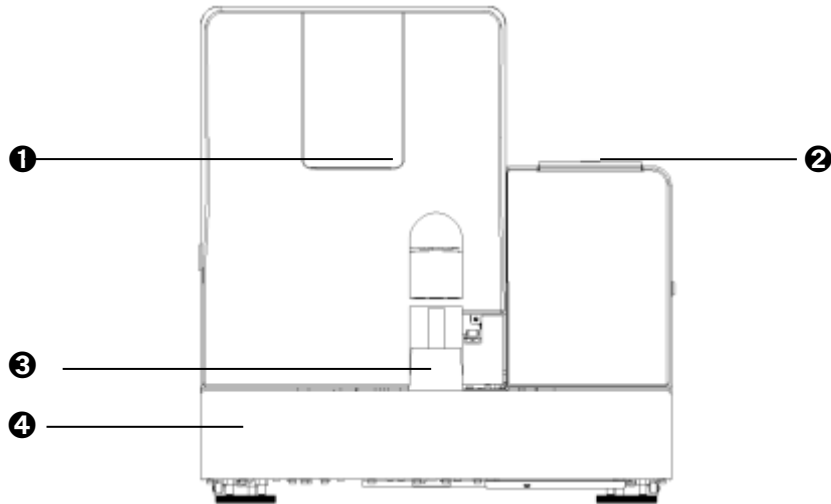

Figure 3-1 Front view of instrument

No.	Parts	Description
1	Status indicator lamp	The working status of instrument (Blue: working and standby mode; orange: instrument failure)
2	Strip-pick cover	Open the strip-pick cover to put in or take out the test strip
3	Emergency site	Site for sample test in priority
4	Rack-in module	For transfer of tube rack

3.2.2 Back view

The structure and relevant important components on back of the instrument are introduced in this section. See the figure below for details:

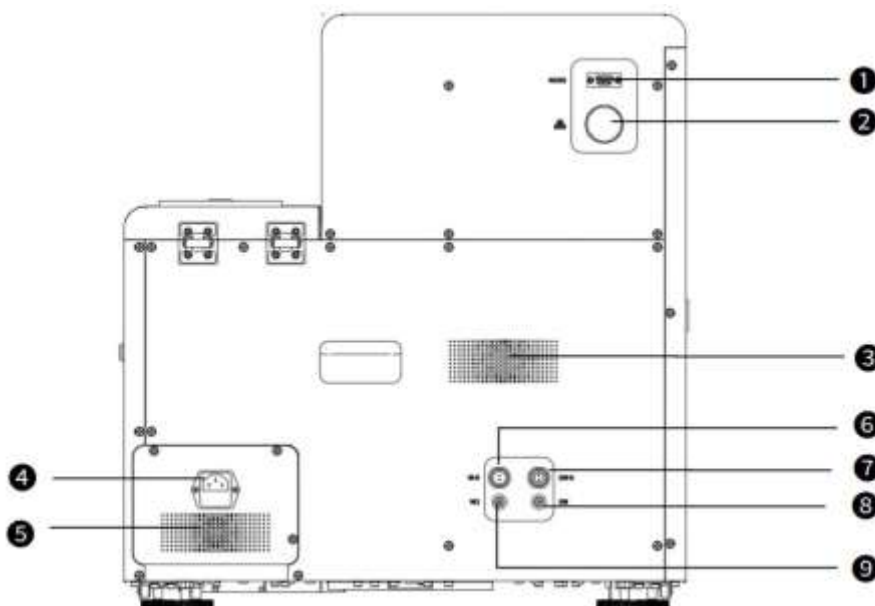

Figure 3-2 Back view of instrument

No.	Parts	Description
-----	-------	-------------

Instrument introduction

1	RS-232 interface	Used to connect the computer for data transmission
2	Network port	Used to connect the computer for image transmission
3	Fan of the whole device	Used for heat dissipation of the instrument
4	Power socket	Connection point of power input line
5	Power supply fan	For heat dissipation of power supply
6	Waste liquid sensor interface	Used to connect the waste liquid sensor
7	Sheath fluid sensor interface	Used to connect the sheath fluid sensor
8	Sheath fluid tube nozzle	Used to connect the sheath fluid tube
9	Waste liquid tube nozzle	Used to connect the waste liquid tube

3.2.3 Left side view

The structure and relevant important components on left side of the instrument are introduced in this section. See the figure below for details:

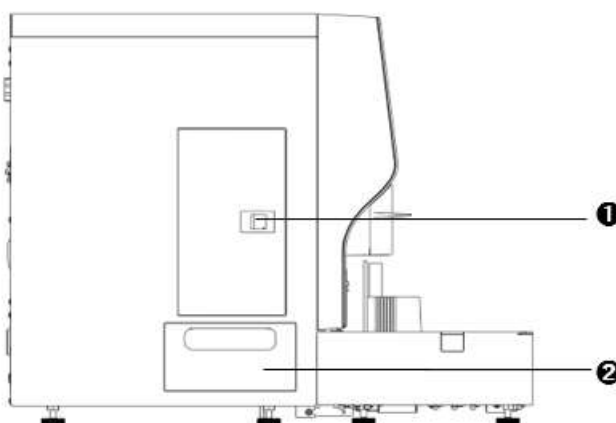

Figure 3-3 Left side view of instrument

No.	Parts	Description
1	Left door	Open the cabin door of sheath fluid buffer bottle
2	Waste strip box	Collect the waste strip after use

3.2.4 Right side view

The structure and relevant important components on right side of the instrument are introduced in this section. See the figure below for details:

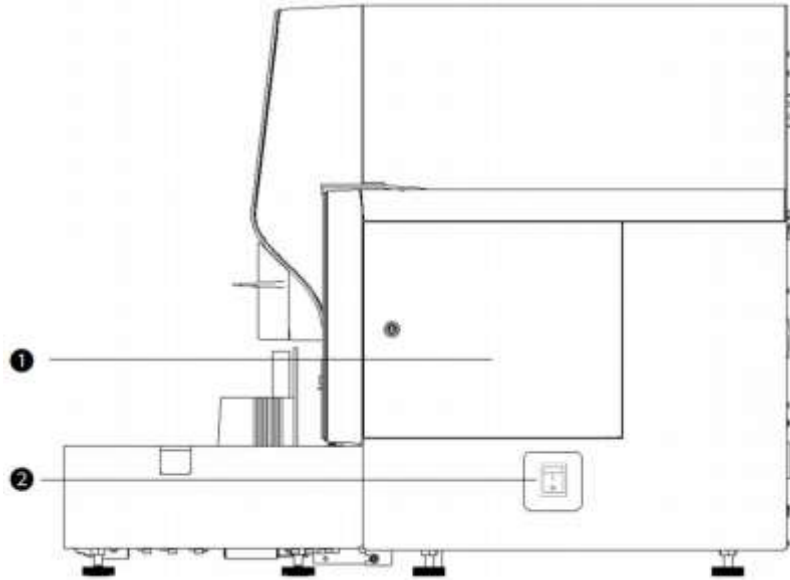

Figure 3-4 Right side view of instrument

No.	Parts	Description
1	Right side door	Used to open the strip-pick door for maintenance of strip-pick structure
2	Power switch	Main power switch of instrument (press "I" to start up and "O" to shut down)

3.3 Performance parameter

The performance parameter information of instrument is mainly described in this section, including the main test items and indicators, and the main performance parameters.

3.3.1 Main test items and indicators

The main test items and indicators of instrument are mainly introduced in this section. Besides, the test items and sample pictures are shown in the following table:

Table 3-1 Main test items and indicators

Items	Description
Test items of sediment	Red blood cells (RBC), white blood cells (WBC), white blood cell clump (WBCC), phagocyte (PHCY), squamous epithelial cells (SQEP), non-squamous epithelial cells (NSE), budding yeast (BYST), yeast with pseudo hyphae (HYST), bacillus (BACI), suspected coccus (SUCCO), sperm (SPRM), mucus (MUCCS), hyaline cast (HYAL), unclassified casts (UNCC), fat, amorphous (AMOR), magnesium ammonium phosphate crystal (MAPH), calcium oxalate monohydrate (COM), calcium oxalate dihydrate crystal (COD), uric acid crystal (URIC), ammonium urate crystal (AUCCR), tyrosine crystal (TYRO), calcium phosphate crystal (CAPH), unclassified









Instrument introduction

Items	Description		
	crystal (UNCX), and the unclassified (UNCL)		
Dry chemical test items	Urobilinogen (URO), bilirubin (BIL), ketone body (KET), occult blood (BLD), protein (PRO), nitrite (NIT), white blood cell (WBC), glucose (GLU), specific gravity (SG), pH, Vitamin C (VC), microalbumin (MALB), creatinine (CRE) and calcium (Ca), urine protein/creatinine ratio (P:C), urine microalbumin to creatinine ratio (A:C)		
Physicochemical test items (optional)	Specific gravity (SG) (optional), turbidity (optional), color (optional), conductivity (optional), and osmotic pressure (reported when conductivity configured)		
Emergency function	Emergency diagnosis test is supported		
Identification of abnormal red blood cells	The function of prompting abnormal red blood cells.		
Test speed	<p>120 tests/hour for urine sediment only</p> <p>240 tests/hour for dry chemical only</p> <p>120 joint tests/hour</p>		
Sample size	Urine sediment mode	<p>Minimum size: 3 mL non-centrifugal urine</p> <p>Suction volume: about 1.6mL</p>	
	Dry chemical mode	Without the physicochemical module	Minimum volume: 3 mL non-centrifugal urine Aspiration volume: about 1.6mL
		With physicochemical module	Minimum volume: 3 mL non-centrifugal urine Aspiration volume: about 1.6mL
	Urine sediment + dry chemical mode	Minimum volume: 3 mL non-centrifugal urine Aspiration volume: about 1.6mL	
Size of sample to be tested	60 samples		
Capacity of test strip cabin	300 strips		
Capacity of waste strip box	300 strips		



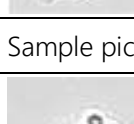





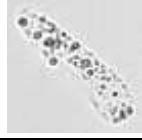

Note 1: the reference intervals of urine protein/creatinine ratio (P:C), urine microalbumin to creatinine ratio (A:C), and the osmotic pressure are 0-200mg/g, 0-30mg/g, and 600-1000mOsm/kgH₂O respectively. For the reference intervals of the 14 items of dry chemical, please refer to the instructions for use of the Urinalysis Strip (Dry Chemistry Method).

Note 2: the osmotic pressure is only used as the research parameter but not as the basis for judging the clinical test results.

Table 3-2 Test items and sample pictures

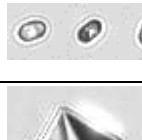
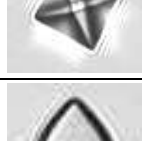
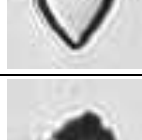
Category	Abbreviation	Sample pictures
Red blood cell	RBC	
White blood cell	WBC	
White blood cell clump	WBCC	
Phagocyte	PHCY	
Squamous epithelial cells	SQEP	
Category	Abbreviation	Sample pictures
Budding yeast	BYST	
Pseudomycelium yeast	HYST	
Bacillus	BACI	
Suspected coccus	SUCO	
Sperm	SPRM	

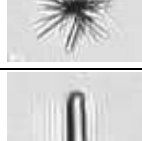
Instrument introduction

Category	Abbreviation	Sample pictures
Mucus	MUCS	
Hyaline casts	HYAL	
Unclassified casts	UNCC	
Fat	FAT	
Amorphous	AMOR	
Magnesium ammonium phosphate crystal	MAPH	
Calcium oxalate monohydrate	COM	
Calcium oxalate dihydrate crystal	COD	
Uric acid crystal	URIC	
Ammonium urate crystal	AUCR	
Tyrosine crystal	TYRO	
Calcium phosphate crystal	CAPH	

Note

- A single particle that cannot be classified according to the above 23 categories is regarded as an unclassified name.
- In order to distinguish and identify the unclassified crystals, unclassified casts, and the unclassified, the operator must review the image and manually identify the image through the operation software to confirm the classification.

3.3.2 Main performance parameters

Table 3-3 Performance parameters of instrument

Name		Description		
Repeatability of urine sediment		Sediment name	Concentration/ (pcs/ μ L)	Coefficient of variation (CV, %)
		Red blood cell	50	≤ 15.0
			200	≤ 8.0
Identification rate of urine sediment test	Coincidence rate of single result with microscopic examination result	Sediment name	Coincidence rate/%	
		RBC	≥ 70	
		WBC	≥ 80	
	Cast	≥ 50		
	False negative rate of urine sediment	The false negative rate of the test results of the instrument shall not be greater than 3%.		
Stability of urine sediment		The coefficient of variation (CV) of cell count results shall not exceed 15% within 8 hours after the instrument is started.		
Carryover of urine sediment		The carryover of instrument to cells shall not be greater than 0.05%.		
Repeatability of urine dry chemical test items		The coefficient of variation (CV,%) of reflectance test results of instrument shall be ≤ 1.0 .		
Accuracy of matching with test strip for urine analysis		The difference between the test result and the indicated value of the reference solution in the same direction shall not exceed one order of magnitude, and no reverse difference is allowed. No negative test result can be obtained from the positive reference solution, while no positive result can be obtained from the negative reference solution.		
Stability of urine dry chemical test items		The coefficient of variation (CV, %) of reflectance test results within 8 hours after the instrument is started shall be ≤ 1.0 .		

Instrument introduction

Name	Description
Carryover of urine dry chemical test items	The positive samples with the highest concentration results of all test items except the specific gravity and pH should be tested, and the negative sample shall also be tested. No positive is allowed for the negative sample.

3.4 Specifications and configuration

The specifications and configuration as well as the working specifications of the instrument are described in this section.

Specifications and configuration

See the following table for the specifications and configuration of the instrument

Table 3-4 Specifications and configuration

Items	Description
Dimensions (Length×Width×Height)	687 mm×512 mm×530 mm
Weight (kg)	Gross weight: 90 kg; net weight: 55 kg
Input/output device	<ul style="list-style-type: none"> • Printer (configured by user) • Handheld barcode scanner
Communication interface	<ul style="list-style-type: none"> • RS232 communication interface (DB9 female) • Network port (RJ45 network port socket)
Power	<ul style="list-style-type: none"> • Voltage: 100V - 240 V~ • Power: 150 VA • Frequency: 50/60 Hz
Fuse	T6.3AH250V
Pollution degree	2
Classification of laser product	Class 1
Noise level	< 66 dB
Minimum computer configuration	<ul style="list-style-type: none"> • CPU: i5 • Memory capacity: 16 GB • Hard disk: 500 GB • Screen: Screen resolution: 1,920 × 1,080 • Graphics card: Support CUDA 10.1 • Memory capacity of graphics card: 6 GB
Software name	Urinalysis Hybrid System software
Software model	U3600、U3601、U3602
Version	V1
Software running	64-bit operating system Windows 10 and its compatible

Items	Description
environment	version
Network conditions	<ul style="list-style-type: none"> • Network type: LAN • Broadband: No requirement <p>Note: to avoid cyber-attack, it is suggested not to connect the computer installed with the software to Internet.</p>
Security software	<ul style="list-style-type: none"> • Name: Windows Defender • Model and specification: Windows Defender • Full version: 4.12.1625.15 and its compatible version • Supplier: Microsoft (Microsoft Corporation) • Requirements for operating environment: Windows 10, 64-bit operating system. The users are recommended to scan and remove the computer virus at least once a month. • Update: It can be updated by user to the latest version, if necessary.
Interface	Connect to the LIS through the network interface or serial port to transmit data in dual ways; Data transmission protocol is HL7 or ASTM.
User access control	Login password is required by the software of instrument for user identification. The software is equipped with a control system for user access, including the identification method (user name and password), type and authority (administrator, operator and reviewer) of the user.

Environmental specifications

The environmental specification of instrument is shown in the following table:

Table 3-5 Environmental specifications

Items	Working conditions	Storage and transportation conditions
Ambient temperature	10°C - 30°C (Temperature fluctuation < 2 °C/H)	-20°C - +55°C
Relative humidity	Not more than 80% (no frost)	Not more than 93%
Atmospheric pressure	70.0 kPa - 106.0 kPa	50.0 kPa - 106.0 kPa
Altitude range	Below 3,000 m	W

Note

The instrument must be used, stored and transported under the specified environmental conditions.

3.5 Software interface

The relevant information on software interface of the instrument is introduced herein. As shown in the figure below, the operation interface of software mainly comprises the toolbar, the status bar, and the functional area.

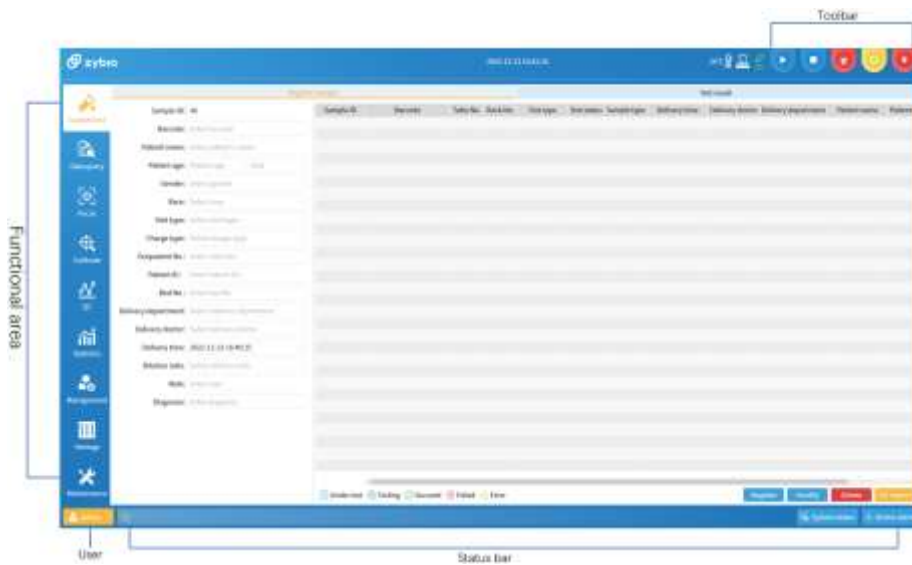









Figure 3-5 Operation interface of software

Toolbar

The toolbar icons and functions are shown in the table below:

Table 3-6 Toolbar icons and functions

Icons	Description
	The user triggers the start button to start the sample test.
	The user triggers the stop button, and thus the instrument stops working to stop the test item.
	The user triggers the emergency button, and the emergency samples can be tested.

Icons	Description
	The user triggers the reset button and the instrument acts for resetting.
	The user triggers the shutdown button and the instrument enters the process of shutdown.
	Displaying the instrument connected currently.
	Displaying the current ambient temperature.
	Displaying the connection status of LIS. For the LIS symbol, red is for disconnection while green for connection.

Status bar

- Status display area
 - Displaying the current status of instrument, as shown in the following example:
 - Standby;
 - Sample testing...
 - Alarm display area

System status: click "System status" to view the detailed status of the instrument.

Instrument alarm: if the instrument contains any error information or fails, the error or alarm information will be displayed in the bottom information bar, and the "Device alarm" button at the bottom of the software interface will also flash. Then, click the flashing "Device alarm" button to enter the alarm information page.

Account

- Account display area
 - Displaying the name of the current login user, such as "admin".
- Software version
 - Click the drop-down box button on the left of "admin" to view the current version of software.

Functional area

Multiple function buttons are contained, which are mainly used to open various functional pages of the instrument, mainly including the following modules:

- Sample test: sample registration can be performed and the test results of the day can be displayed.
- Data query: the sample test results can be reviewed, including the historical results.
- Focus: the registration, deletion and execution of focusing can be performed.
- Calibrate: test can be performed for morphological calibration and the calibration of physicochemical units (optional).
- QC: the QC information setting, application for QC test and querying of QC results can be operated.

Instrument introduction

- Statistics: the workload, login information and maintenance records can be counted.
- Maintenance: the unit module reset, instrument priming, manual triggering of daily and routine maintenance, and diagnostic operation can be performed.
- Management: the following settings can be made, including user management, reagent management, gender, age, race, type of visit, charge type, inspection department and doctor, sample type, dilution ratio and exception identification.
- Settings: the language selection, IP setting, instrument setting, and report setting of the instrument can be performed.

4 Operation principles

The operation principles of the Urinalysis Hybrid System, including the routine test of urine, and the qualitative and quantitative counting of urine sediment, is described in this chapter.

4.1 Test principle of urine sediment

The urine sediment test of the instrument is based on the principle of flow microscopy imaging.

The hydrodynamic system of the instrument is composed of a special flow cell in shell structure. After sampling by the instrument, the sample enters the flow cell, and the injection pump works to pump the sheath fluid into the flow cell, so that the sample entering the shell structure of the flow cell is wrapped by the sheath fluid. Under the action of sheath fluid, the sample liquid flows through the shell structure of the flow cell in a single layer of cells. Meanwhile, the high-frequency light source, shaped by the lighting component, illuminates the shooting area of sediment at strobe frequency. Then, adjust the imaging component by magnification. The camera takes photos at the same frequency, and transmits the captured image data of sediment to the computer software. The computer software will perform the image segmentation to the sediment target on the image, extract the features of the target image in terms of morphology, statistics, frequency domain and texture, and thus normalize these features as the input of the classifier. Then, through the classification and calculation by the identification algorithm of the computer software, the tested urine sample will be discharged into the waste liquid container. As shown in the figure below:

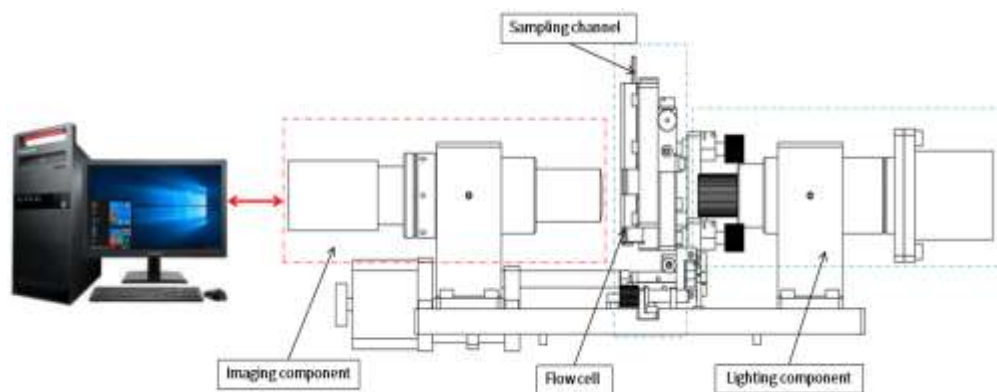

Figure 4-1 Schematic diagram of imaging principle

The sheath flow technology, high-speed camera technology and image identification technology for tests by the instrument are described as follows:

- Sheath flow technology: the sheath fluid used by the instrument for test is an isotonic, particle-free buffer solution, capable of ensuring that the sediment in the urine sample always flow in a single-layer manner. The flow cytometry technology is adopted to ensure that each sediment is photographed and imaged at high speed by flowing in front of the microscope lens and CCD camera within the focus range of the microscope lens. In addition, the urine flows in a diffused way, which can also effectively avoid the accumulation of sediment.
- High-speed camera technology: the urine sample enters the flow cell in the wrap of

Operation principles

sheath fluid and flows in front of the objective lens in a flat laminar flow, with its thickness and position just within the focus of the microscope. According to the sheath flow principle, any particle passing through will directly aim at the lens with the maximum cross-sectional area. When the visual field of each microscope is illuminated by LED light source, the sediment passing through is photographed instantaneously. The CCD camera takes 450 images containing sediment for each sample within a specific period of time. As shown in the figure below:

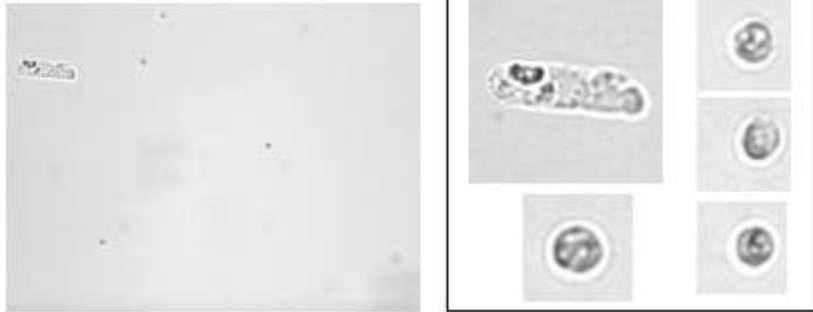

Figure 4-2 Images of sediment

- Image identification technology: the automatic identification software of sediment and the image identification technology can quickly extract the images of sediment particles, and identify and classify them according to the characteristics, such as morphology, texture and frequency domain, of the captured "particles".

After classification by the automatic software of sediment, the concentration of sediment is calculated according to the number of captured "particle" images and the volume of scanned urine samples. The result unit can be expressed in the number per microliter or in the number per high/low power field.

4.2 Test principle of strip

The Urinalysis Hybrid System analyzes the content of biochemical components in urine through the color change caused by the reaction of the reagent block on the test strip with the biochemical components in urine according to the principle of photoelectric colorimetry.

When the test strip soaked with urine sample is transmitted to the test area and further by the synchronous belt to the place right below the optical detector for test. After the reagent blocks on the test strip subjected to the chemical reaction are irradiated by the light source, the reflected light is received by the detector. Each reagent block in the test strip reacts independently with various elements of the urine to show different colors. The depth of color is proportional to an element in the urine. The darker the color of the reacted reagent block, the greater the amount of absorbed light, the smaller the amount of reflected light, and the smaller the reflectivity. On the contrary, the lighter the color, the smaller the amount of absorbed light, the larger the amount of reflected light, and the greater the reflectivity. In other words, the depth of color is positively correlated with the concentration of an element in the urine sample.

4.3 Test principle of turbidity

The light from the luminescent tube on the turbidimeter passes through the sample and detects how much light is scattered by the particles in the sample in the direction of 90° of the incident light. This measurement method of scattered light is called the scattering method. Generally, the turbidity of urine is divided into four gradients: "Clear", "Slightly turbid", "Turbid", "Very turbid".

The formula for measuring the turbidity by scattering method is:

$$T = (SS/TS - SW/TW)/K$$

Where:

T: Turbidity level

SS: Scattering luminosity grade of urine sample

TS: Emission luminosity grade of urine sample

SW: Scattering luminosity grade of wash solution

TW: Emission luminosity grade of wash solution

K: Coefficient

4.4 Test principle of color

The sample color is tested by RGB color sensor. Specifically, the sample is irradiated by white light-emitting diode, of which the R, G and B values are detected by the color sensor after transmission. Then, the sample color is obtained according to the R, G and B values.

4.5 Test principle of specific gravity

The light of the light-emitting diode becomes a beam through a gap and lens device. Besides, the light passes through a prism tank containing urine and then radiates on the detector. The refractive index varies according to the specific gravity of urine in the prism tank, and thereby the light angle related to the detector also varies.

The calculation formula of refractive hydrometer method is:

$$SG_x = (SG_H - SG_L) (K_x - K_L) / (K_H - K_L) + SG_L$$

Where:

SG _x	Specific gravity of sample solution
SG _H	Specific gravity of high-concentration solution
SG _L	Specific gravity of low-concentration solution
K _x	Position coefficient of sample solution
K _H	Position coefficient of high-concentration solution
K _L	Position coefficient of low-concentration solution

The specific gravity of sample solution changes with the temperature of the urine sample. The specific gravity changes by 0.001 for every 3 °C change in temperature.

4.6 Test principle of conductivity

The conductivity unit is designed with 2 electric corrosion-resistant conductive joints to test the conductivity of electrolyte solution in urine. The temperature sensor is designed in the instrument.

The calculation formula of conductivity is:

Conductivity before temperature compensation: $Cond_{notemp} = 9.994/R$

Operation principles

Conductivity after temperature compensation $Cond_{temp}$

$$= \begin{cases} \frac{Cond_{notemp}}{(0.0169 * Temper + 0.5583)} & 1 \leq Temper < 11 \\ \frac{Cond_{notemp}}{(0.018 * Temper + 0.5473)} & 11 \leq Temper < 21 \\ \frac{Cond_{notemp}}{(0.0189 * Temper + 0.5281)} & 21 \leq Temper \end{cases}$$

Where:

Condnotemp	Conductivity before temperature compensation
R	Corrected resistance
Condtemp	Conductivity after temperature compensation
Temper	Temperature value

5 Daily operation

This chapter mainly introduces specific procedures of daily test operations, including pre-test preparations, viewing, modifying, printing, reviewing, and re-examination of test results, as well as precautions during the test.

Note

- When connecting the drain, be careful not to fold or flatten it.
- If the foam in the sample is higher than 5 mm, the foam in the sample shall be reduced through settlement to less than 5 mm before the test.
- Avoid put any viscous sample under the test to prevent clogging the sample probe.
- The waste liquid container connected to the instrument shall be placed on the ground, and the waste liquid tube shall be as vertical as possible to the ground to ensure the smooth flow of the waste liquid.

Caution

- The operator shall stay away from the sampling position of the sample probe to avoid injury.
-

5.1 Preparations before test

This section mainly introduces preparations before the test, including sample preparation, test tube requirements, barcode usage requirements, and pre-test checks, etc.

5.1.1 Sample preparation

Considerations when preparing samples are as follows:

- Collect urine in clean or sterilized utensils.
 - Use fresh urine samples which shall be kept out of direct sunlight. If the test cannot be performed within 1 hour after collection, please seal the urine and store it in the refrigerator under 2°C–8°C. The test shall be completed within 2 hours. The sample shall be returned to room temperature before the test.
 - Do not add preservatives, disinfectants and cleaning agents to the urine sample.
 - Do not centrifuge the sample, and mix the urine sample thoroughly before the test, or otherwise the sensitivity of the test result will be affected.
 - When testing the sample, the instrument must be used for the test in the required operating environment. If the temperature exceeds the range, the accuracy of the test result may be affected.
 - The instrument requires a test sample volume of no less than 3 mL.
-

Note

- If the sample volume is 3 mL, it is necessary to use a pointed test tube. It is recommended that the test tube not be fully filled with the sample during the test to avoid the liquid overflow when the instrument automatically mixes and sucks the sample.
 - If the concentration of urine sample is high, dilute the sample before performing an analysis.
-

5.1.2 Prepare strips and desiccants

Prepare strips and desiccants according to the requirements below.

Note

- The strips prepared must be consistent with the settings in the instrument. To ensure the reliability of the test results, check the strip type first before use.
 - The strip chamber is capable of holding up to 300 strips, and the strips cannot be left in the strip chamber for more than 24 hours. The damped strips will affect the accuracy of the test results, so please put the strips in the strip chamber back into the strip vial and cap the vial tightly after all the tests are over.
 - When placing the strips, ensure that the black end of the strip is in the same direction as the label affixed to the strip chamber to avoid failure to select the strip.
 - Please use the desiccants in the strip vial.
-

- Strips

Open the strip-pick cover **1** at the right side of the instrument, adjust the black end direction of the strip in accordance with the label **3** affixed to the strip chamber **4**, and feed the strips to the strip chamber.

- Desiccant I

Open the strip-pick cover **1** at the right side of the instrument, place the desiccant on the desiccant area **2**, and ensure that the strip-pick cover is properly closed.

- Desiccant II

There is also a desiccant chamber at the side of the strip-pick module, and the desiccant can be replaced when cleaning the strip-transport plate (see chapter 14.2). To open this desiccant chamber, twist the hand screw **5** (flat side down) of the fixed desiccant chamber **6**.

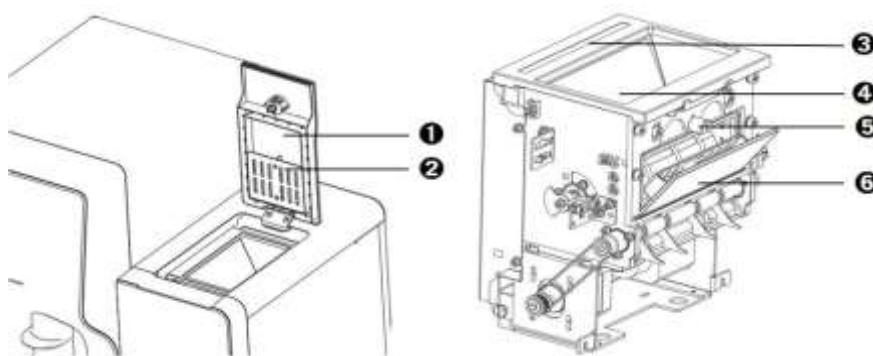

Figure 5-1 Strip and desiccant placement illustration

No.	Part name
1	Strip-pick cover
2	Desiccant area
3	Label for the strip placement
4	Strip chamber
5	Hand screw
6	Desiccant chamber

5.1.3 Test tube requirements

The test tube requirements are as follows:

- Sample tube specifications: The outer diameter of the tube is 14–15 mm, and the length is 90–110 mm. The shape of the test tube shall be regular, and there shall be no extrusion deformation. Test without the cover opened can be achieved with the test tube sealed with aluminum foil and tin foil of same specification. For the specific test tube types for the without the cover opened, please contact Zybio.
- Tube rack specifications: Use the tube rack that came with the instrument.

5.1.4 Barcode requirements

This section mainly introduces the types, specifications, and specific use requirements of barcodes.

- Barcode type: accepted barcodes are Code 39, Code128, EAN128, Code 93, Codebar, Interleaved 2 of 5.
- Barcode specifications

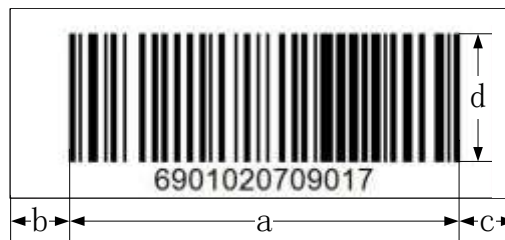

Figure 5-2 Barcode specifications illustration

The specific requirements on barcode specifications are as follows:

Barcode height: $d \leq 20$ mm

Barcode label width: $a \leq 45$ mm

Blank space on both sides of barcode: $b \geq 3$ mm, $c \geq 3$ mm

- The barcode shall be flat, wrinkle-free, pollution-free, and the lines shall not be printed with imperfections, or otherwise the barcode cannot be read correctly.

When pasting the barcode, the lower edge of the barcode shall be positioned more than 25 mm from the bottom of the tube to ensure the barcode can be scanned correctly. At the same time, during the process of putting the test tube into the tube rack, ensure that all barcode labels can be seen from the longitudinal notch of the tube rack, and make sure the test tube is placed vertically, and closely against the base.

When the barcode type is Code 39, Code 128, Code 93, the characters can be used including letter, digit, -, blank space, +, /, %, and \$.

Daily operation

- The numbers of digits for different types of barcodes are shown in the table below:

Table 5-1 Table of numbers of digits of barcode types

Sample barcode type	Code number identification
Code39	4-12
Code128	4-24
Code93	4-16
Codabar	4-15
Interleaved 2 of 5	4-22

5.1.5 Inspection before startup

Please perform inspection according to the following requirements before powering on the instrument to ensure that the instrument is ready.

- Check the power supply: the power supply is correctly grounded and provides the correct voltage.
- Check the power cord: the power cord is firmly and tightly connected.
- Check the strips: the test strips have been correctly placed in the strip chamber.
- Check the sheath fluid: keep enough sheath fluid in the sheath fluid container.
- Liquid waste: keep the liquid waste bucket empty.
- Check the tubing: the tubing is not kinked, broken, or poorly connected.
- Check the waste strip box: there is enough space in the waste strip box for waste strips.
- Check Printer: check whether the power cable and data cable to the printer are connected correctly, and whether the printing paper used by the printer is in sufficient stock.

5.2 Sample test

This section mainly introduces the main process of test on sample, including powering on, software login, instrument status confirmation, test on sample, emergency diagnosis test, patient's information modification, alarm information confirmation, etc.

5.2.1 Powering on

Before the test, turn on the following power sources:

- Power on the computer and the monitor, respectively.
- Turn on the printer's power switch (if configured), and mount the printing paper.
- Turn on the power switch of the instrument.

5.2.2 Login onto software

The steps for software login are as follows:

Enter the username and password in the "Login" dialog box, and click on "Login".

Note

The default user name of the system administrator is "admin", and the default password is "admin". It is recommended to change the password when using it for the first time to prevent others from tampering with the rights of the administrator. If the operator forgot

the password, Zyblio or the local distributor shall be contacted.

After the login is successful, the instrument performs the startup initialization test. After the instrument calibration is carried out automatically, and if the power-on self-check result is normal, and the main interface of the operating software will be successfully entered. At this point, the startup process is over.

5.2.1 Confirmation of instrument status

After logging in onto the software, please confirm the status of the instrument first. The specific confirmation information is as follows:

- Status confirmation

Click "System status" at the bottom of the main interface of the software to enter the "System status" interface, as shown in the figure below.

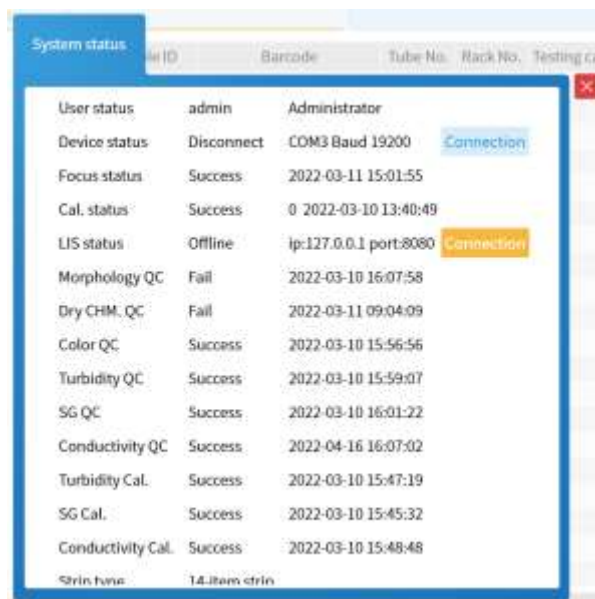

Figure 5-3 "System status" interface

- Alarm confirmation

When an alarm sets off in the instrument, in addition to the flashing alarm icon "Device alarm", if a buzzer sound prompt is also needed, click on "Settings" in the main button area on the left side of the interface to enter the "Settings" interface, and set the "Audio alarm" to "On" and click on "Save". In this way, the instrument will have double prompts during the alarm.

- Morphological focusing, calibration

- Focus: operate according to "7.1 Morphological focusing", and execute it once a day when the instrument is turned on.
- Calibrate: operate following "8.1 Morphological calibration", at least once a month.

- Physicochemical unit calibration

Hydrometer, turbidimeter: operate following "8.2.1 Specific gravity calibration", "8.2.2 Turbidimeter calibration" and "8.2.3 Conductivity calibration", at least once a month.

- Dry chemical calibration

Test strip test: operate according to "9.6 Standard strip test".

- Quality control

Operate following "9.3.2 Morphological quality control testing", "9.4.2 Dry chemical

Daily operation

quality control testing", "9.5.2 Physicochemical unit quality control testing", and execute it once a day when the instrument is turned on.

- Replenish

The instrument needs to consume sheath fluid when performing "Focus", "Calibrate", "QC" and "Sample test". When the remaining sheath fluid is insufficient, it should be replenished, or otherwise the test cannot be performed normally. See Chapter 11.1 for the method of sheath fluid replenish.

Note

The instrument shall be carried out in the order of "Focus", "Calibrate" and "QC". When calibration is not required, it shall be carried out in the order of "Focus" and "Calibrate".

5.2.2 Sample test

This section mainly introduces the main information on the test on sample. The main steps of the test on sample are as follows:

- (1) Place the barcoded tube with the urine sample on the tube rack, keeping the tube perpendicular to the rubber base;
 - (2) Place the tube rack on the right side of the rack-in module of the instrument;
 - (3) Click "Start" in the shortcut key area at the top of the main interface, and the "Information" interface will pop up;
 - (4) Users can import the test mode from LIS. and set the test mode locally(In local mode, you can choose to test all samples for dry chemistry, all samples for morphology, all samples for full mode testing and one sample for one mode). Enter the initial sample number. Click "Start test", and the tube rack is automatically transferred to the sample suction position of the instrument for the test. Click "Register sample" at the upper left of the "Sample test" interface to display the information on the sample under tested;
 - (5) Click "Test result" at the top right of the "Sample test" interface to display a list of results after the test is completed.
-

Note

- This "Test result" interface only display the results of tests completed on that day and the results that have not been released. If a historical result needs to be queried, click "Data query" in the main button area of the interface. For specific operations, please refer to "6 Data query".
 - If the test sample needs to be diluted, please use a diluent that applies to the model of this product and is with a registration certificate. Before the test, pull down the options and select the set dilution ratio in the "Dilution ratio" box on the "Sample test" interface.
-

5.2.3 Emergency test

As shown in Figure 5-3, pull out the emergency diagnosis rack ❶ to the outside. Put the emergency diagnosis sample tube ❷ into the round hole on the emergency diagnosis rack. Push the diagnosis rack back to its original position.

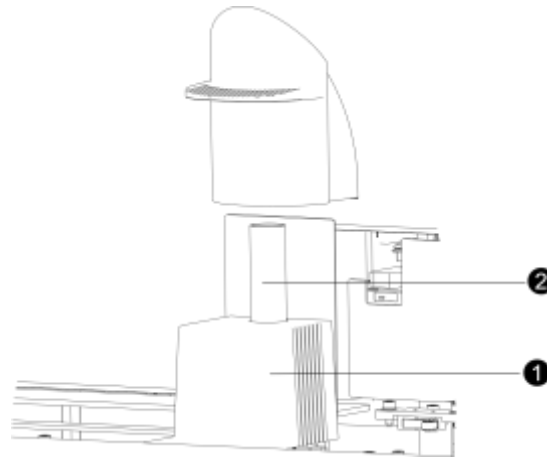

Figure 5-4 Emergency diagnosis sample placement

No.	Part name
1	Emergency tube rack
2	Emergency sample tube

Click "Emergency" in the shortcut button area at the top of the interface. Choose the test mode and click "Confirm". The sample probe will automatically move to the emergency diagnosis position to suck the sample. After the test is completed, the result will be displayed in the "Test result" list in the "Sample test" interface. For emergency diagnosis samples, the sample number is displayed as En (e.g. E1, E2) in the work list, and the rack/tube number of an emergency diagnosis sample is displayed as null.

5.2.4 Modification of patient information

This section mainly introduces the modification of patient information.

Note

Editing of patient's information can be done during and after the test on sample before the re-examination.

Before or after the sample test, if the LIS is connected, "LIS import" will be displayed at the lower right corner of the "Register sample" and "Test result" interfaces of "Sample test". Click "LIS import" to import the relevant LIS information to the sample registration interface, and the sample barcodes scanned by the built-in barcode scanner will correspond to the imported information. Basic sample test information can also be manually registered on the left side of the sample registration interface. To delete and modify the sample information that has been registered, click "Delete" or "Modify" at the bottom of the interface.

In the "Test result" interface, click on the page-turning button at the bottom left of the interface to turn pages, and click on the result in the list to select the sample.

Enter the barcode number, patient name, age unit, medical record number, bed number, and note in the patient's information column; select the patient's gender, age unit, race, visit type, charge type, delivery department & doctor, sample type, dilution ratio and other information (mnemonic symbols can be used during registration), click "Modify" to complete the information editing and modification of patient's information, and the

Daily operation

patient's information is automatically displayed in the result list.

- Age unit: enter the age in the input box and select the appropriate age unit in the drop-down list box. This function is set in the "Management" window of the main button area. For specific operation, please refer to "11.4 Age unit".
- Gender: select an appropriate gender from the drop-down list box. This function is set in the "Management" window of the main button area. For specific operations, please refer to "11.3 Gender".
- Race: select an appropriate race from the drop-down list box. This function is set in the "Management" window of the main button area. For details, please refer to "11.5 Race".
- Visit type: select an appropriate type of visit from the drop-down list box. This function is set in the "Management" window of the main button area. For details, please refer to "11.6 Visit type".
- Charge type: select an appropriate type of fee from the drop-down list box. This function is set in the "Management" window of the main button area. For details, please refer to "11.7 Charge type".
- Delivery department & doctor: select the department category and the doctor's name in the drop-down list box. This function is set in the "Management" window of the main button area. For specific operations, please refer to "11.8 Delivery department & doctor".
- Dilution ratio: select an appropriate type from the drop-down list box. This function is set in the "Management" window of the main button area. For specific operations, please refer to "11.9 Dilution ratio".
- Abnormal mark: enter a customized abnormality mark in Name. This function is set in the "Management" window of the main button area. For specific operations, please refer to "11.10 Abnormal markAbnormal mark".

5.2.5 Confirmation of alarm information

If an error occurs during the test, the software will send an alarm prompt, and an alarm icon for "Device alarm" will flash in the shortcut key bar in the lower right corner of the screen. Click the "Device alarm" in the lower right corner of the interface to display brief descriptions such as the number of alarms, alarm codes, alarm levels, time of alarm, etc.

Note

When an alarm occurs, please refer to the alarm handling method to deal with it. If error still cannot be cleared, please contact Zybio.

5.3 Retest of sample

This section mainly introduces the specific operations of the retest of sample.

(1) Before starting retest

After the initial test is over, if the sample needs to be retested, select the sample to be retested in the result list on the test result interface.

(2) Initiation of retest

Click "Retest", select the test mode, place the sample to be reviewed on the tube rack, and place the tube rack on the right side of the rack entry module of the instrument. Click "Confirm" on the interface to retest the sample.

(3) Viewing of retest result

The retest result is displayed on the "Sample test" interface. The retest results (if the retest sample number is 10, the retest result will be displayed in the list with the sample number as 10#1) are displayed in the list, and the retest sample number is selected.

Click "Review comparison" to display the comparison result before and after the retest.
Click "Replace" to replace the test result before the retest with the result after it.

Note

- Retest can only be carried out for the test result on the same day.
- To retest the sample, "Retest" must be clicked on to send the retest command.

5.4 Test result

In the "Test result" interface list, double-click on the selected sample information after the test to view the test result.

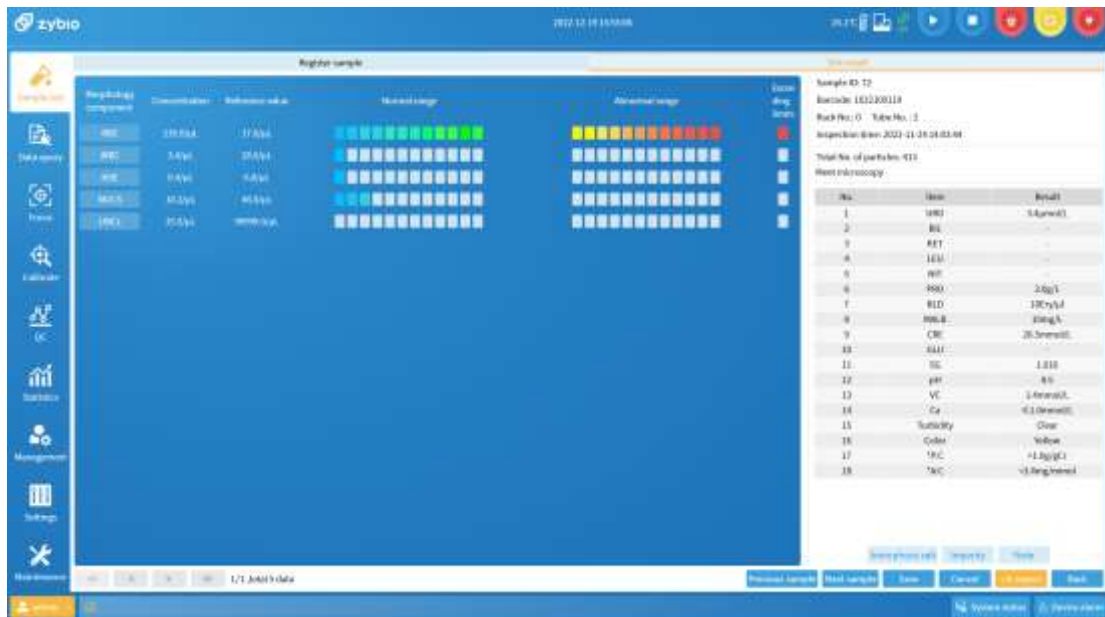

Figure 5-5 "Test result" interface

- The right side of the interface displays the urine dry chemical and physiochemical results of the corresponding sample and the total number of particles detected in morphological detection, among which "*P: C", "*A: C" and "Osmotic" are research parameters.
- Results of sediment are displayed on the left side. Each sediment can be viewed in the result and is with a reference value range. A result in the normal range is green; a result in the abnormal range is red, and it is displayed in red in the display area where it exceeds the standard.
- If there are too many sediments in the sample test result, scrolling down can be down along the list.
- Click "Previous sample" or "Next sample" to browse other test results.

5.4.1 Browsing of various test images

Click on the button with a representation of the cell in the result of the sediment, and the image of the particle will be displayed in an enlarged form. For example, click "Red Blood Cells", and the result is shown in the figure below.



Figure 5-6 Sediment image browsing interface

5.4.2 Manual classification of images

In case of misidentification, the image can be reclassified as follows:

- Select the image that does not match the name of the sediment in the sediment image interface. Click the corresponding category button on the right side of the screen to complete the reclassification. Click "Back", return to the "Test result" interface, then click on "Save", and the above modification can be saved and confirmed.

The followings are three ways to select particle pictures on the sediment image interface:

- Click the image directly to select it or cancel the selection;
- Hold down the left mouse button and drag the mouse, a rectangular box will be displayed. After releasing the button, all images in the rectangular box will be selected;
- Click the particle name button, all particle images on the current page will be selected, click the button again to deselect the images.
- If the manual classification has been completed and the operation is found to be with errors, before clicking on "Save", "Cancel" can be clicked on the test result interface for cancellation and re-classification.

The following categories can be automatically identified:

Erythrocytes, leukocytes, leukocyte masses, phagocyte, squamous epithelial cells, non-squamous epithelial cells, budding yeasts, pseudohyphae, bacilli, cocci, sperms, mucus filaments, hyaline casts, pathological casts, fat, amorphous, magnesium ammonium phosphate crystals, calcium oxalate monohydrate, calcium oxalate dihydrate crystals, uric acid crystals, ammonium urate crystal, tyrosine crystals, calcium phosphate crystals, unclassified crystals, and the unclassified.

The following categories can be manually identified:

Table 5-2 Categories can be manually identified

Cell	Cast	Crystallization	Others
Red Blood Cells	Red blood cell cast	Amorphous phosphate crystal	Trichomonas

Cell	Cast	Crystallization	Others
Poikilocyte	White blood cell cast	Sodium urate crystal	/
Erythrocyte mass	Granular cast	Calcium carbonate crystal	Artifact
Large red blood cell	Broad cast	Cystine crystal	/
Microcyte red blood cell	Waxy cast	Leucine crystal	/
Polymorphonuclear Leukocyte	Epithelial cast	/	/
/	Fatty casts	/	/

5.4.3 Sediment size browsing

Enter the sediment image interface, select the image of the sediment of the test item, move the mouse to the top of the sediment to display the diameter of the sediment, and make judgments for clinicians more intuitive, as shown in the figure below.



Figure 5-7 Sediment size browsing interface

5.5 Result review

To review a sample result, select a test result in "Test result" on the "Sample test" interface. Click "Review" at the bottom of the interface. "Yes" is displayed under the corresponding "Review" in the list. The reviewer is the current logged-in user by default. The review time is the current time. And this indicates that the review is completed. If batch review is to be performed, click on "Batch review" at the bottom of the "Test result" interface of the "Sample test" interface, a prompt box will pop up. Select the date and the starting and ending sample numbers to be reviewed in the prompt box. Click "Confirm". "Yes" is displayed under the "Review" corresponding to the selected sample result in the list. The reviewer is the currently logged-in user by default. The review time is the current time. And this indicates that the review is completed.

Click to select the reviewed test results, and click "Cancel review" to cancel the review.

5.6 Query for test results

Click "Search" in the "Test result" interface to enter the corresponding interface. Enter the query conditions (sample number, barcode, patient name, emergency diagnosis or not, medical record number, test time, etc.). Click "Confirm". And the result of the sample that meet the conditions will be displayed on "Test result" interface.

5.7 Preview and printing of report

The printed report can display up to 16 particle images. Select the image in the "Browse sediment size" interface, right click on it to select "Add mark", and the flagged image will display a green dot at the upper right corner. Go back to the result search interface, click "Save" to save the flag or click "Cancel" to cancel the flag. After the particle image is successfully flagged, it can be displayed on the printed report.

Report preview and printing operations are as follows:

- Report preview and printing of single sample result: Select a test result in "Test result" on the "Sample test" interface. Click "Print" to preview the result record to be printed. If the report needs to be printed, click on "Print" again.
- Report preview and printing of batch samples: To print reports in batches, click on "Batch print", and enter the starting and ending sample numbers for batch printing in the "Sample ID" input box, and then click on "Print".

Note

The starting sample number for batch printing must be less than or equal to the ending sample number.

5.8 Deletion of result

The operation of sample result deletion is as follows:

- Delete the single sample result: If a sample result is to be deleted, select a test result in "Test result" on the "Sample test" interface, click on "Delete" at the bottom of the interface. A prompt box will pop up showing "Deleting selected {0} pieces of data?" Click "Confirm", and a prompt box showing will pop up showing "Deleted!", indicating that the deletion is successful.
- Delete the sample results in batches: If deletion in batches is to be done, select multiple or all the checkboxes in front of the serial numbers, click on "Delete", and a prompt box will pop up showing "Deleting selected {0} pieces of data?" Click "Confirm", and a prompt box showing will pop up showing "Deleted!", indicating that the deletion is successful.

5.9 LIS Export

Export of test results to LIS: Check one or more pieces of sample information in "Test result" on the "Sample test" interface, and click on "LIS export" to upload the test results to the LIS.

5.10 Erythrocyte phase prompt function

This section mainly introduces the erythrocyte phase prompt function.

The screenshot shows the Zzybio software interface. On the left, there is a sidebar with icons for Home, Data Query, Files, Laboratory, Statistics, Management, Settings, and Help. The main area is titled 'Register sample' and contains a form with fields for Patient name, Patient age, Gender, Race, Visit type, Charge type, Outpatient No., Patient ID, and Address. Below the form, there is a 'Delivery department' field and a 'Delivery time' field. The right side of the interface displays a 'Microbiology result' table with columns for No., Item, Result, Abnormal mark, Reference value, and Unit. Below this table, there is a 'Sample ID' field and a 'Barcode' field. The bottom of the interface features a toolbar with buttons for 'Home', 'Data Query', 'Files', 'Laboratory', 'Statistics', 'Management', 'Settings', and 'Help'.

Figure 5-8 "Test result" interface

In the test result list, detailed information on the erythrocytes of the sample after the test is displayed. If the number of normal erythrocytes in the sample is less than 30%, heterogeneous erythrocytes and the detailed proportion will be displayed. If the number of normal erythrocytes in the sample is between 30% and 70%, mixed erythrocytes and the detailed proportion will be displayed. If the number of normal erythrocytes in the sample is greater than 70%, homogeneous erythrocytes and the detailed proportion will be displayed.

5.11 Sleep

When the sleep time setting is enabled in the system configuration interface, if the fluidic-related operations have stopped for the time period preset by the operator, the Urinalysis Hybrid System will enter the sleep mode.

When the Urinalysis Hybrid System is in sleep mode, any reset or any analysis can wake up it. After a reset, it will enter the standby mode. And an analysis can be performed only after it is woken up. During the sleep, the sample probe will be immersed in the cleaning pool and the syringe will be pulled down, which is intended to protect them from any damage. Please note that these will not happen for the standby mode.

5.12 Shut down

After all the tests are over, follow the steps below to shut down the instrument.

- (1) Click "Shut down" button on the right side of the toolbar, a dialog box will be displayed. There are 3 options including "Exit", "Exit after cleaning", and "Cancel" on the dialog box.
- (2) Click "Exit" to exit the software; click "Cancel" to cancel the shutdown operation; click "Exit after cleaning", the information "Please put cleanser in place, and then click 'Confirm'" will be displayed.
- (3) After the tube with wash solution is placed properly, click "Confirm" and the instrument will perform cleaning automatically. The information "Cleaning done. Please turn off instrument, and program will be shut down in 30s!" will be displayed.
- (4) Press the switch to "O" to turn off the instrument. The software will be shut down after counting down or click "Shut down" to exit directly.

6 Data query

This chapter mainly introduces the relevant content of data query. Users can select query conditions according to actual needs, view the data query list, and perform operations such as clearing and exporting of historical data.

6.1 Query

Click "Data query" on the main interface for the query, export, upload to LIS, and printing of the test result, as shown in the following figure:

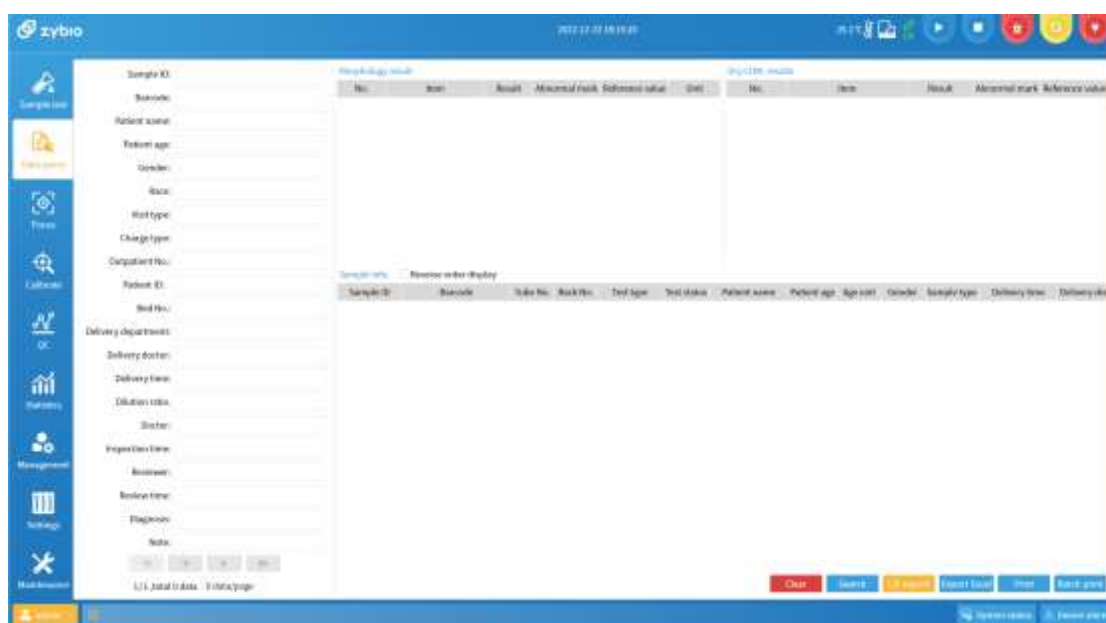

Figure 6-1 "Data query" interface

On the "Data query" interface, click "Search" at the bottom, and the "Test result query" dialog box will pop up.

6.1.1 Query by sample number

The steps to make the query by sample number are as follows:

- (1) On the "Test result query" interface, enter the starting sample number in the sample number input box. The ending sample number must be greater than or equal to the starting sample number. At the same time, select the test time (the default is 0:00 to 24:00 on that same day). For example: the starting sample number is 1, the ending sample number is 3, and the inspection time is selected from March 3, 2021 to 24:00 on March 4, 2021;
- (2) After entering the information, click "Confirm", and all historical records with sample numbers 1 to 3 from March 3, 2021 to March 4, 2021 at 24:00 will be displayed in the data query list. Click "Cancel" after entering the information, and no query for historical records will be made.

6.1.2 Query by barcode number

The steps to query by barcode number are as follows:

- (1) Enter the complete barcode number or a part of the barcode number in the barcode number input box on the "Test result query" interface, and select the inspection time (the default is 0:00 to 24:00 on that same day), for example: The barcode number is "123456", and the inspection time is selected from March 3, 2021 to 24:00 on March 4, 2021;
- (2) After the input, click "Confirm", and all the historical records including 123456 in the barcode number from March 3, 2021 to March 4, 2021 at 24:00 will be displayed in the data query list; Click "Cancel" after entering the information, and no query for historical records will be made.

6.1.3 Query by patient's name

The steps to make a query by a patient's name are as follows:

- (1) Enter the patient's full name or a part of the patient's name in the patient's name input box on the "Test result query" interface, and select the test time (the default is 0:00 to 24:00 on that same day), for example: The patient's name is "Wang", and the test time is selected from March 3, 2021 to 24:00 on March 4, 2021;
- (2) After the input, click "Confirm", and all historical records with "Wang" in the patient's name from March 3, 2021 to March 4, 2021 at 24:00 will be displayed in data query list; Click "Cancel" after entering the information, and no query for historical records will be made.

6.1.4 Query by department

The steps to make a query by department are as follows:

- (1) Click "Data query", and then click "Search" to select the corresponding department name from the drop-down box of the department on the "Test result query" interface. Select the name of the department and select the inspection time (the default is 0:00 to 24:00 on that same day), for example: The name of the department is "Internal Medicine", and the inspection time is selected from March 3, 2021 to 24:00 on March 4, 2021;
- (2) After inputting, click "Confirm", and in the data query list, all the historical records submitted by the internal medicine department from March 3, 2021 to March 4, 2021 at 24:00 will be displayed; Click "Cancel" after entering the information, and no query for historical records will be made.

6.1.5 Query by inspection time

The steps to make a query by inspection time are as follows:

- (1) Click "Data query", and then click on "Search". Click the inspection time on the test result query interface for a drop-down box, and set the inspection start time for the query (the default is 0:00 to 24:00 on that same day). The ending time shall be greater than or equal to the starting time, and the ending time cannot exceed 24:00 of the day. For example: The inspection time is selected from March 3, 2021 to 24:00 on March 4, 2021;
- (2) After the input, click on "Confirm", and all historical records from March 3, 2021 to March 4, 2021 at 24:00 will be displayed in the data query list; Click "Cancel" after entering the information, and no query for historical records will be made.



The inspection time query condition can be used alone, or in conjunction with the sample number, barcode number, patient's name, and department information for the query.

6.2 Data query list

According to the description in Section 6.1, query for all historical data that meets the conditions during the inspection period from 2021.01.01 to 2021.03.03, and the data query list will be returned after the query is successful.

On the "Data query list" interface, select a piece of data and double-click on it to enter the "Detailed data" interface. The left side of the "Detailed data" interface is the morphological result, and the displayed items include morphology component, concentration, upper limit, normal range, abnormal range, out of limits. The sample information on the upper right side of the interface includes the sample ID, inspection time, and total number of particles; bottom right is a list of dry chemical results.

Click "Previous sample" and "Next sample" to view the detailed data interface of other samples; click on "Back", and the page will return to the "Data query list" interface.

Click "Morphological component", such as "RBC", to enter the "Image preview" interface of erythrocytes. On the "Image preview" interface, move the mouse over the component image to display the cell diameter. Click "Previous category" and "Next category" to jump to preview interfaces of other components; Click "", " " to view all the component images on the interface; The bottom of the page displays how many images this component has, how many images there are on the current page, and how many pages the component image has; Click "Back" to return to the "Detailed data" interface.

6.3 Clear historical data

Click "Clear" on the "Data query" interface, and all data in the current list will be cleared.

6.4 Export of historical data

Click "Export Excel" on the "Data query" interface, and the "Export path" pop-up box will pop up. After setting the path, click on "Save", and the list will be exported to the corresponding path and saved.

6.5 Preview and printing of reports

The preview and printing of the report includes the preview and printing of a single sample, as well as the preview and printing of batch samples.

- Report preview and printing for a single sample: select a piece of sample information from "Sample Info." on the "Data query" interface, and click on "Print" to preview the result record to be printed. If the report is to be printed, click on "Print" again. Click "Cancel", the report will not be printed. See Appendix B for the inspection report template.
- Report preview and printing of batch samples: if the reports are to be printed in batches, click on "Batch print", enter the starting and ending sample numbers for batch printing in the "Sample ID" input box, or select the inspection time interval of different dates for batch printing. Click "Confirm" to print in batches; click on "Cancel" to not print the reports.

6.6 LIS export

The "LIS export" function will upload the flagged images on "Browse sediment image" to the LIS. Select one or more pieces of sample information on the "Data query" interface, click on "LIS export", and upload the test result to the LIS.

7 Focus

In order to have the sediment of urine clearly photographed and imaged when it passes through the focusing plane of the microscope, focusing shall be performed for the instrument once a day, and then the sample test can be conducted.

7.1 Morphological focusing

Follow the steps below for morphological focusing.

(1) Preparations before focusing

Pour about 7 mL of well-mixed sediment focusing fluid into a clean test tube, and place the tube at the front of the tube rack.

Note

The sediment focusing fluid needs to be mixed by turning upside down and again for 1 min to 3 min.

(2) Considerations for focusing

- Please use the focusing fluid designated by our company.
- Focusing shall be performed once the instrument is powered up for the first time each day.

(3) Focusing test

- 1) Place the tube rack on the right side of the rack-in module;
- 2) Click "Focus" in the main button area on the left side of the main interface to enter the "Focus" interface;
- 3) On the right side of the focusing interface, enter the lot number, name, and manufacturer according to the description information of the focusing fluid, and select the validity period in the drop-down calendar (Barcode registration: click on the input box after the barcode number. Use an external barcode scanner to scan the barcode of sediment analysis focusing fluid, or manually enter the barcode number in the input box after the barcode number. The lot number, name, manufacturer, and validity period of the focusing fluid will be displayed automatically). Click "Register", the input focusing information will be displayed in the focusing registration list on the left. After clicking on this information, click on "Run focus", the sample probe will perform sample suction action. After the focusing test is over, the interface will pop up a "Pass" or "Failed" prompt. Whether the focusing has passed the test is displayed in the focusing result list below the "Focus" interface, and the focusing time and focusing result will be displayed on the "System status" interface;
- 4) If the focusing is successful, "☑" will be displayed in the status bar at the bottom of the interface, and the instrument will automatically enter the standby mode;
- 5) If focusing is unsuccessful, "☒" will be displayed in the status bar at the bottom of the interface. Do not perform the sample test at this time. Perform the focusing again. If it is still unsuccessful, please contact Zybio or its distributor.

(4) Focusing result query

Click "Search" under the focusing result, and the "Focus result" interface will pop

Focus

up. Enter the focusing lot number, name, manufacturer, and focusing status in the window; after selecting the focusing time, click on "Confirm ", and the focusing result interface will display all corresponding focusing results.

(5) Printing of focusing result

Select a piece of information in the focus result list and click "Print" to preview the focus record to be printed. If printing is to be done, click on "Print" again.

(6) LIS export

Export of focusing results to LIS: Select one or more focus results on the "Focus" interface. Click "LIS export", and upload the test results to the LIS.

(7) Deletion of focusing result

Check a single or multiple focusing results that need to be deleted. Click "Delete", and a prompt will pop up showing "Deleting selected {0} pieces of data?". Click "Confirm", and a prompt will pop up showing "Deleted!". Check to see that the checked information has been deleted.

8 Calibrate

In order to obtain accurate measurement results, it is necessary to determine the calibration coefficient for the urine analysis bias under the specified conditions through calibration. In order to obtain accurate urine analysis results, please periodically calibrate the instrument according to the procedure in this chapter.

Note

Users shall use Zybio's calibration solution, and store and use it in strict accordance with the required environment.

8.1 Morphological calibration

This section mainly introduces the content of morphological calibration, including calibration solution storage, calibration frequency, calibration operation, and query for and printing of calibration results.

(1) Storage of calibration solution

- The calibration solution is a solution containing aldehydated erythrocytes, and the number of particles contained is indicated on the label of each bottle of reagent.
- The calibration solution shall be stored at 2°C–8°C. It should not be frozen. It shall be equilibrated to room temperature before use.

(2) Calibration frequency

Calibration shall be performed at least once a month. Focusing shall be performed before calibration.

(3) Preparations before calibration

- 1) Shake up for 1 to 3 minutes before use , avoid vigorous shake and keep it upright;
- 2) The calibration solution can be used immediately after opening, and is for a single time of use only. The rest cannot be used. Calibration solutions of different batches cannot be mixed for use;
- 3) Mix and pour the calibration solution from the same bottle into 5 clean test tubes (≥5 mL each);
- 4) Place the 5 test tubes on the tube rack.

(4) Calibration test

- 1) Place the tube rack on the right side of the rack-in module;
- 2) Click "Calibrate" in the main button area on the left side of the main interface to enter the "Calibrate" interface;
- 3) On the right side of the "Calibrate" interface, enter the calibration lot number, calibration name, manufacturer, and calibration target value according to the instructions on the calibration solution, and select the validity period in the drop-down calendar for the validity period (Barcode registration: Click the input box after the barcode number. Use an external barcode scanner to scan the barcode on the calibration solution bottle of Zybio, or manually enter the barcode in the input box after the barcode number. The calibration lot number, calibration name,

manufacturer, validity period, and calibration target value will be displayed after the code scanning is done.) Click "Register", and the entered calibration information, click on this information will be displayed in the calibration registration list on the left. Click "Run calibration", and the sample probe will perform a suction action. Each test tube is tested twice and the test is done for a total of ten times. After the five test tubes are completely tested, the interface will pop up a prompt showing "Pass" or "Failed", calibration status related information will be displayed in the calibration result list at the bottom of the "Calibrate" interface, and at the same time the calibration time and calibration factor will be displayed on the "System status" interface;

- 4) If the calibration is successful, the status bar at the bottom of the interface will display "Pass", and the instrument will automatically enter the standby mode;
 - 5) If the calibration fails, the status bar at the bottom of the interface will display "Failed". At this time, the calibration solution shall be replaced with another batch and the calibration shall be performed again. If it is still unsuccessful, please contact Zybio or its agent.
- (5) Query for calibration result
- 1) Click "Search" at the bottom right of the calibration interface, and the "Cal. result" interface will pop up;
 - 2) Enter the calibration lot number and calibration status in the window, select the calibration date, and click on "Confirm". And all corresponding calibration results will be displayed on the calibration result interface.
- (6) Printing of calibration result
- Select a piece of information in the calibration result list, and click on "Print".
- (7) LIS export
- Export of calibration results to LIS: Check one or more calibration results on the "Calibrate" interface, and click on "LIS export" to upload the test results to the LIS.
- (8) Deletion of calibration result
- Check a single or multiple calibration results to be deleted, click on "Delete", and a prompt will pop up showing "Deleting selected {0} pieces of data?" Click OK, and a prompt will pop up showing "Deleted!". Check to see that the checked information has been deleted.

8.2 Physicochemical unit calibration (optional unit)

On the "Calibrate" interface, click on "PHYC unit Cal." to enter the "PHYC unit Cal." interface.

Note

Specific gravity, turbidity, and conductivity shall be calibrated monthly.

8.2.1 Specific gravity calibration

This section mainly introduces the specific operation of specific gravity calibration, which is as follows.

- (1) Calibration solution preparation
- 1) Take three test tubes. Pour no less than 3.5 mL of Level 3 specific gravity calibration solution into the first test tube. Pour no less than 3.5 mL of Level 2 specific gravity calibration solution into the second test tube. Pour no less than 3.5 mL of Level 1 specific gravity calibration solution into the third test tube;
 - 2) Place the Level 3, Level 2, and Level 1 specific gravity calibration solutions at the
-

-
- first, second, and third positions of the tube rack, respectively;
- 3) On the "PHYC unit Cal." interface, select the hydrometer for the calibration type, enter the calibration lot number, calibration name, and manufacturer according to the instructions on the calibration solution, select the validity period in the drop-down calendar for the validity period, enter the Level 3 specific gravity value in the high calibration value box, enter the specific gravity value of Level 2 in the middle calibration value box, and enter the specific gravity value of Level 1 in the low calibration value box (barcode registration: Click the input box after the barcode number. Scan the barcode of the calibration solution with an external barcode scanner, or manually enter the barcode number in the input box after the barcode number. After scanning the barcode, the calibration lot number, calibration name, manufacturer, expiration date, and the three horizontal target values will be displayed automatically.) Click "Register", and the entered calibration information will be displayed in the calibration registration list on the left;
 - 4) Place the tube rack on the right side of the rack-in module. Click "Run calibration" to perform hydrometer calibration, and a prompt will automatically pop up showing "Pass" or "Failed" after the calibration is completed.
- (2) Query for calibration result
- 1) Click "Search" below, and the "Cal. result" interface will pop up;
 - 2) Enter or select the calibration result in the window, select the calibration date, click on "Confirm", and all corresponding calibration results will be displayed in the calibration list.
- (3) Printing of calibration result
- Select a piece of information in the calibration result list, click on "Print", and the printing of the selected result information will be achieved.
- (4) Transmission of calibration result to LIS
- When the system is connected to the LIS, select a piece of information in the calibration result list, click on "LIS export", and the selected information will be uploaded to the LIS.
- (5) Deletion of calibration result
- Select a single or multiple pieces of information in the calibration result list, click on "Delete", and a prompt will pop up showing "Deleting selected {0} pieces of data?" Click on "Confirm", and a prompt will pop up showing "Deleted!". Check to see that the checked information has been deleted.

8.2.2 Turbidimeter calibration

This section mainly introduces the specific operation of turbidimeter calibration, which is as follows.

- (1) Calibration solution preparation
 - 1) Take two test tubes. Pour Level 2 turbidity calibration solution (≥ 3.5 mL) into the first tube as a high turbidity calibration solution. Pour Level 1 turbidity calibration solution (≥ 3.5 mL) into the second tube mL) as a low turbidity calibration solution;
 - 2) Place the high and low turbidity calibration solutions at the first and second positions of the tube rack respectively;
 - 3) On the "PHYC unit Cal." interface, select the turbidimeter for the calibration type, enter the calibration lot number, calibration name, and manufacturer according to the instructions on the calibration solution, select the validity period in the drop-down calendar for the validity period, enter the Level 2 turbidity value in the high calibration value box, enter the Level 1 turbidity value in the low

calibration value box (barcode registration: Click the input box after the barcode number. Scan the barcode of the calibration solution with an external barcode scanner, or manually enter the barcode number in the input box after the barcode number. After scanning the barcode, the calibration lot number, calibration name, manufacturer, expiration date, and the two level target values will be displayed automatically.) Click "Register", and the entered calibration information will be displayed in the calibration registration list on the left;

- 4) Place the tube rack on the right side of the rack-in module. Click "Calibrate" to perform turbidimeter calibration, and a prompt will pop up automatically showing "Pass" or "Failed" after the calibration is completed.
- (2) Calibration query
- 1) Click "Search" below, and the "Run calibration" interface will pop up. Enter the calibration result in the window, select the calibration date, click on "Confirm", and all corresponding calibration results will be displayed in the calibration list;
 - 2) Printing of calibration result;
 - 3) Select a piece of information in the calibration result list, click on "Print", and the printing of the selected result information will be achieved.

(3) Transmission of calibration result to LIS

When the system is connected to the LIS, select a piece of information in the calibration result list, click on "LIS export", and the selected information will be uploaded to the LIS end.

(4) Deletion of calibration result

Select a single or multiple pieces of information in the calibration result list, click on "Delete", and a prompt will pop up showing "Deleting selected {0} pieces of data?". Click on "Confirm", and a prompt will pop up showing "Deleted!". Check to see that the checked information has been deleted.

8.2.3 Conductivity calibration

This section mainly introduces the specific operation of conductivity calibration, which is as follows.

(1) Calibration solution preparation

- 1) Take three clean empty test tubes. Pour ≥ 3.5 mL of Level 3 conductivity calibration solution into the first test tube;
- 2) Pour ≥ 3.5 mL of Level 2 conductivity calibration solution into the second tube;
- 3) Pour ≥ 3.5 mL of Level 1 conductivity calibration solution into the third test tube. Place them at the first, second and third positions on the same tube rack in sequence;
- 4) On the "PHYC unit Cal." interface, select the conductivity for the calibration type, enter the calibration lot number, calibration name, and manufacturer according to the instructions on the calibration solution, select the validity period in the drop-down calendar for the validity period, enter the Level 3 conductivity value in the high calibration value box, enter the conductivity value of Level 2 in the middle calibration value box, and enter the conductivity value of Level 1 in the low calibration value box (barcode registration: Click the input box after the barcode number. Scan the barcode of the calibration solution with an external barcode scanner, or manually enter the barcode number in the input box after the barcode number. After scanning the barcode, the calibration lot number, calibration name, manufacturer, expiration date, and the three horizontal target values will be displayed automatically.) Click "Register", and the entered calibration information will be displayed in the calibration registration list on the left;
- 5) Place the tube rack on the right side of the rack-in module, select the

"Conductivity" option, and click "Run calibration" to perform conductivity calibration. After the calibration is completed, a prompt will appear automatically showing "Pass" or "Fail".

(2) Query for calibration result

- 1) Click "Search" below, and the calibration result interface will pop up;
- 2) Enter the calibration result in the window, select the calibration date, click on "Confirm", and all corresponding calibration results will be displayed in the calibration list.

(3) Printing of calibration result

Select a piece of information in the calibration result list, and click on "Print".

(4) Transmission of calibration result to LIS

When the system is connected to the LIS, select a piece of information in the calibration result list, click on "LIS export", and the selected information will be uploaded to the LIS end.

(5) Deletion of calibration result

Select a piece of information in the calibration result list, click on "Delete", and a prompt will pop up showing "Deleting selected {0} pieces of data?" Click on "Confirm", and a prompt will pop up showing "Deleted!". Check to see that the checked information has been deleted.

9 Quality control

The function of the quality control (QC) program is to verify and test for the correctness of the analysis of the instrument through the test on the urine control and the collection of quality control data. The purpose of quality control testing is to ensure the accuracy and repeatability of the test results.

9.1 Control

Quality control materials

- A control is used for the quality control of the measurement result of the instrument; Positive control is used as abnormal quality control, and negative control is used as normal value quality control, both of which are used to test for whether the instrument can measure and count correctly.
- The sediment positive control is a solution containing a fixed number of erythrocytes in an ionically balanced fluid. For cell counts, see Particle Counts under the Positive Control tab.
- The sediment negative control is a particle-free solution.
- A control must be kept refrigerated but never frozen, and equilibrated to the room temperature before each use.

Quality control frequency

- To ensure the accuracy of the test result for the sediment, positive and negative controls for sediment shall be performed at least once a day or as per the standards in the laboratory quality control procedure manual, and a focusing shall be performed before the quality control.
- In order to ensure the accuracy of the dry chemical test result, Zybio's positive and negative urine analysis controls can be used for the quality control testing in the following situations.
 - At the start of the test each day;
 - At replacement with a new tube of test strips;
 - When changing the operator;
 - When the test result is in doubt.
- In order to ensure the accuracy of the test result of the physicochemical unit (optional unit), a quality control testing can be carried out with the matched specific gravity, turbidity, color, and conductivity controls in the following situations (when the physicochemical unit is selected for equipment).
 - Perform test once a month;
 - Perform test when the test result is in doubt.

9.2 Quality control settings

This section mainly introduces the main contents of quality control settings, including the morphological alarm range and dry chemical quality control settings.

- Morphological alarm range
Click "QC" in the main button area on the left side of the main interface, and then click on "Set QC" to enter the quality control settings interface.

Select "Exceed $\pm 1SD$ ", "Exceed $\pm 2SD$ ", "Exceed $\pm 3SD$ ", indicating that the positive quality control result is judged by deviation limits as per SDs of 5%, 10%, and 15% respectively. Select the common alarm range, click on "Save", and a confirmation dialog box will pop up; click "Confirm" to save the set quality control range of morphological quality control.

- Dry chemical control settings

By selecting each quality control item displayed in the dry chemical quality control list at the bottom of the "Set QC" interface, the upper and lower limits of each quality control item can be set; by checking whether the negative target value and the positive target value are enabled, clicking on "Save", the quality control settings are saved.

9.3 Morphological quality control

On the "QC" interface, click on "Morphology QC" to enter the "Morphology QC" interface.

9.3.1 Quality control registration

Morphological quality control registration includes the addition and deletion of quality control items. The details are as follows:

- Addition of quality control items

Method 1: Manual registration

Enter the corresponding information in the input boxes after the quality control lot number, quality control name, manufacturer, and target value according to the instructions on the control. Select "Negative" or "Positive" for the control information description. Click "Register" after entering all the information, and the entered quality control information will be displayed in the quality control registration list on the left. (The negative control target value is 20 by default and cannot be modified).

Method 2: Barcode registration

Click the input box after the barcode number. Scan the barcode of the control with an external barcode scanner, or manually enter the barcode number in the input box after the barcode number. The quality control lot number, quality control name, quality control type, manufacturer, validity period, and quality control target value will be displayed automatically after the code scanning is done. Click "Register", and the input quality control information will be displayed in the quality control registration list on the left. Barcode registration supports registration of multiple quality controls and a single quality control.

- Deletion of quality control items

- (1) Select the quality control item to be deleted in the quality control registration list on the "Morphology QC" interface;
- (2) Click "Delete", and a confirmation dialog box will pop up; click "Confirm", and the selected quality control item will be deleted.

9.3.2 Morphological quality control testing

The main steps of the morphological quality control testing are as follows:

- (1) Use of control

Shake up for 1 to 3 minutes before use , avoid vigorous shake and keep it upright.

Note

Since the sediment control (negative) does not contain particles, it is not necessary to be shaken well before use.

(2) Quality control testing considerations

In order not to affect the quality control result, please use the control designated by Zybio.

(3) Preparations before quality control testing

- 1) Pour about 3.5 mL of sediment control (positive) and 3.5 mL of sediment control (negative) into two test tubes;
- 2) Place the two tubes on the tube rack in the order where they are listed in the quality control registration.

(4) Quality control testing

- 1) Place the tube rack on the right side of the rack-in module. Select the quality control registration column to be tested in the quality control registration table on the "Morphology QC" interface. Click "Run QC", and the sample probe will automatically perform the suction action. Wait for the test tubes on the tube rack are done testing, the quality control related information and quality control status will be displayed in the quality control result list area on the screen;
- 2) If the quality control fails, "⊗" will be displayed in the "QC status" column of the quality control result. At this time, the control shall be replaced with one of another lot number and the procedure shall be executed again. If it is still unsuccessful, please contact Zybio or its distributor.

9.4 Dry chemical quality control

Click "Dry CHM. QC" on the "QC" interface to enter the "Dry CHM. QC" interface.

9.4.1 Quality control registration

The dry chemical quality control registration includes the addition and deletion of quality control items, and the details are as follows:

- Addition of quality control item

Method 1: Manual registration

On the quality control registration interface on the right, select "Negative" or "Positive" in the quality control items according to the instructions on the control, enter the quality control lot number, quality control name, manufacturer, select the validity period in the drop-down calendar for validity period, click on "Register" after entering all the information, and the input quality control information will be displayed in the quality control registration list on the left.

Method 2: Barcode registration

On the quality control registration interface on the right, click on the input box after the barcode number, use an external barcode scanner to scan the barcode of the control, or manually enter the barcode number in the input box after the barcode number, and the quality control item, quality control lot number, quality control name, manufacturer, and validity period will be displayed automatically after code scanning is done. Click "Register", and the input quality control information will be displayed in the quality control registration list on the left. Barcode number registration supports registration of multiple quality controls and a single quality control.

Quality control

- Deletion of quality control item

Select the quality control item to be deleted in the quality control registration list of the "Dry CHM. QC" interface, click "Delete", and the selected quality control item will be deleted.

9.4.2 Dry chemical quality control testing

The main steps of dry chemical quality control testing are as follows:

- (1) Pour the matched urine dry chemical control (negative) and urine dry chemical control (positive) into two test tubes respectively;
- (2) Put the test tubes containing the urine dry chemical control (negative) and the urine dry chemical control (positive) on the tube rack in turn, and place the tube rack on the right side of the rack-in module;
- (3) On the quality control registration interface, click to select the registered negative and positive controls in turn; then click on "Excute QC", and the sample probe will automatically perform the suction action. After the testing is done, the quality control result will be displayed in the data column of the current chart, and the instrument will automatically enter the standby state;
- (4) If the quality control fails, "⊗" will be displayed in the "QC status" column of the quality control result. At this time, the control shall be replaced with one of another lot number and the procedure shall be executed again. If it is still unsuccessful, please contact Zybio or its distributor.

9.5 Physicochemical unit quality control (optional unit)

On the "QC" interface, click on "PHYC unit QC" to enter the "PHYC unit QC" interface.

9.5.1 Quality control registration

The physicochemical unit quality control registration includes the addition and deletion of quality control items. The details are as follows:

- Addition of quality control item

Method 1: Manual registration

On the "QC" interface, click "PHYC unit QC" and select the "Color", "Turbidity", "SG", and "Conductivity" items in the quality control item column of the quality control registration area. Enter the quality control lot number, quality control name, manufacturer according to the instructions on the control of the selected item. Select the quality control level. Select the validity period in the drop-down calendar for the validity period. The target value for each level needs to be entered for specific gravity and conductivity items according to the instructions on the control. After all information is completely input, click "Register", and the input quality control information will be displayed in the quality control registration list on the left.

Method 2: Barcode registration

Click the input box after the barcode number, scan the barcode of the quality control with an external barcode scanner, or manually enter the barcode number in the input box after the barcode number. The quality control lot number, quality control name, quality control type, manufacturer, validity period, and quality control target value will be displayed automatically after the code scanning is done. Click "Register", the input quality control information will be displayed in the quality control registration list on the left. Barcode registration supports the registration of multiple quality controls and a single quality control under a quality control item.

- Deletion of quality control item

Select the quality control item to be deleted in the quality control registration list of the "PHYC unit QC" interface. Click "Delete", and the selected quality control item will be deleted.

9.5.2 Physicochemical unit quality control testing

The main steps of the physicochemical unit quality control testing are as follows:

- (1) Pour the "Color", "Turbidity", "SG", and "Conductivity" controls with different levels into the corresponding test tubes according to the registered quality control type;
- (2) Place the test tubes containing the corresponding "Color", "Turbidity", "SG", and "Conductivity" controls with different levels on the tube rack, and place the tube rack on the right side of the rack-in module;
- (3) On the quality control registration interface, click to select the registered information; then click to execute quality control, and the sample probe will automatically perform the sample suction action. After the test is completed, the quality control result will be displayed in the quality control result data column below, and the instrument will automatically enter the standby state;
- (4) If the quality control fails, "⊗" will be displayed in the "QC status" column of the quality control result. At this time, the control shall be replaced with one of another lot number and the procedure shall be executed again. If it is still unsuccessful, please contact Zybio or its distributor.

9.6 Standard strip test

This section mainly introduces the main content of standard strip test, including dry chemical standard strip test and test result query.

- Dry chemical standard strip test
 - (1) Empty the test strip cabin, take out the random standard strip, and put them into the test paper compartment according to the marked direction;
 - (2) Empty the waste strip bin, and place dry, clean white paper in the waste strip bin;
 - (3) Click "Standard strip test" on the QC interface to enter the Standard Strip Test interface. In the test registration area on the right, enter the barcode number and manufacturer; or click on input box after the barcode number, scan the standard barcode with an external barcode scanner, then manually enter the manufacturer, click on "Register" after all information are input. Check the information to be tested in the left test information area and click on "Excute test", and the instrument will execute the test on the standard strip. The results will be displayed in the data list in turn on the "Standard strip test" interface;
 - (4) The standard strips for which the test has been completed will be transferred to the waste strip bin. Put standard strips in the standard strip bin;
 - (5) If the standard strip test is unsuccessful, "⊗" will be displayed in the status column of the test result, and the test needs to be done again. If it is still unsuccessful, please contact Zybio or its distributor.

Note

- Never test the standard strip after it is dipped in water (or other liquid).
 - Please use the standard strip specified for the instrument.
 - If the surface of the standard strip is contaminated or damaged, please contact the
-

Quality control

supplier. Do not continue to use the standard strip for testing.

- To guarantee correct test results, it is recommended that the instrument be tested with a standard strip every 1 to 2 weeks.
- Standard strip test result query
Click "Standard strip test" to enter the Standard Test interface. Select the test status and time for the query. Click "Search" to display the standard test result that meets the conditions.
- Deletion of standard strip test result
On the standard test result interface, select one or more test results, click on "Delete", and a prompt will pop up showing "Deleting selected {0} pieces of data?" Click OK, and a prompt will pop up showing "Deleted!". Check to see that the checked information has been deleted.
- Printing of standard strip test result
On the standard test result interface, select one or more test results, and click on "Print" to print the results of the selected information.

9.7 QC review

Click "QC review" on the "QC" interface to enter the "QC review" interface, where the query for the quality control information for which the test has been done.

Select "Morphology QC", "Dry CHM.", "PHYC unit" to switch to display the "Morphology QC", "Dry CHM.", "PHYC unit" quality control review interfaces.

9.7.1 Morphological quality control query

On the "QC review" interface, click on "Morphology QC" to enter the "Morphology QC review" interface.

- Quality control query review
 - (1) Select the quality control button to switch to the query of the corresponding quality control type, and enter different operators to make the query for the quality control information under such a user;
 - (2) Enter the corresponding parameters in the input boxes after the quality control lot number and quality control name;
 - (3) Click the drop-down menu after "QC status" and "QC time", and click on "Search" to display the morphological quality control query result;
 - (4) Click "Reset" to clear the quality control query condition.
- Deletion of quality control results
 - (1) On the "Morphology QC" interface, select the quality control result to be deleted in the quality control list, click on "Delete", and a confirmation dialog box will pop up;
 - (2) Click "Confirm", and the selected quality control results will be deleted.

9.7.2 Morphological quality control graph

Click "QC graph" on the "QC" interface to enter the QC graph interface.

About quality control graph

- The horizontal axis of the quality control graph represents the date or time of the quality control, and the vertical axis represents the quality control line.
- Each point in the quality control graph corresponds to a quality control result, and the points are connected by line segments.

Query and printing of quality control graph

- Select "Morphological QC" on the "QC graph" interface.
- Select the corresponding parameters in the drop-down boxes for quality control lot number, quality control name, and quality control manufacturer, select the starting time, ending time, and the quality control type, and click on "Search" to display the morphological quality control graph.
- Click "Print" to preview the result record to be printed.
- If the quality control graph is to be printed, click on "Print" again, and the printing will be done.
- Click "Reset", and the query condition will be reset.

9.7.3 Dry chemical quality control query

Click "Dry CHM." on the "QC review" interface to enter the "Dry CHM. QC review" interface, where the query for the negative or positive quality control record within a certain time range can be made.

- Quality control query review
 - (1) Select the quality control button to switch to the query of the corresponding quality control type, and enter different operators to make the query for the quality control information under such a user;
 - (2) Enter the corresponding parameters in the input boxes after the quality control lot number and quality control name;
 - (3) Click the drop-down menu after "QC status" and "QC time", select the corresponding query parameters, click on "Search", and the dry chemical quality control query result will be displayed;
 - (4) Click "Reset" to clear the quality control query condition.
- Deletion of quality control results
 - (1) On the "Dry CHM. QC" interface, select the row of the quality control result to be deleted in the quality control list;
 - (2) Click "Delete". Click "Confirm" in the pop-up dialog box, and the selected quality control results will be deleted.

9.7.4 Dry chemical quality control graph

Click "Dry CHM." on the "QC graph" interface to enter the "Dry CHM. QC graph" interface.

- (1) Negative or positive quality control records within a certain time range can be queried for;
- (2) Select the corresponding parameters from the drop-down boxes for quality control date, quality control type, quality control lot number, quality control name, and manufacturer, click on "Search", and the dry chemical quality control graph will be displayed. Click "Reset" to clear the quality control query condition;
- (3) Click "Print" to preview the result record to be printed. If the quality control graph needs to be printed, click on "Print" again, and the printing will be done.

9.7.5 Printing

Click "Print", and the printing of the quality control information will be done.

9.7.6 Physicochemical unit quality control query (optional unit)

Click "PHYC unit" on the "QC review" interface to enter the "PHYC unit QC review" interface, where the query for the quality control records on color, turbidity, specific gravity, and conductivity within a certain time range can be made.

- Quality control query review
 - (1) Check "Color", "Turbidity", "SG" and "Conductivity" in the drop-down boxes for

Quality control

- the quality control items, and enter the corresponding parameters in the input boxes after the quality control lot number and quality control name;
- (2) Click the drop-down menus after "QC status", "QC time", and "QC level", click on "Search", and the query results of physicochemical unit quality control will be displayed;
- (3) Click "Reset" to clear the quality control query condition.
- Deletion of quality control results
 - (1) On the PHYC unit QC search interface, select the row of the quality control result to be deleted in the quality control list, and click on "Delete";
 - (2) Click "Confirm" in the pop-up dialog box, and the selected quality control results will be deleted.

9.7.7 Physicochemical unit quality control graph (optional unit)

Click "PHYC unit" on the "QC graph" interface to enter the "PHYC unit QC graph" interface, where the query for the quality control records on color, turbidity, specific gravity, and conductivity within a certain time range can be made.

- (1) Select the corresponding parameters from the drop-down boxes for quality control date, quality control lot number, quality control name, quality control level, manufacturer, and quality control items, click on "Search", and the quality control graph of the physicochemical unit will be displayed;
- (2) Click "Reset" to clear the quality control query condition;
- (3) Click "Print", and the printing of the quality control graph will be done.

9.7.8 LIS export

Click "LIS export" to export the quality control results through the LIS system.

10 Statistics

This section mainly introduces the statistical functions.

- Workload statistics
 - (1) Click "Workload statistics" on the workload statistics interface;
 - (2) After entering the statistical information, click "Search" to make the query in statistical results;
 - (3) Click "Print" to print the statistical results, and click "Reset" to reset the statistical information.
- System log
 - (1) Click "System log" to enter the system log interface;
 - (2) After entering the log information, click on "Search" to make the query in system log;
 - (3) After checking the system log results, click on "Export" to export the checked logs, and click on "Reset" to reset the log information.
- Maintenance record
 - (1) Click "Maintenance record" to enter the maintenance record interface;
 - (2) After entering the system maintenance information, click on "Search" to make the query in system maintenance records;
 - (3) After checking the maintenance record, click on "Print" to print the maintenance record, and click on "Reset" to reset the maintenance information.

11 Management

This chapter mainly introduces the management of the Urinalysis Hybrid System. Users may conduct settings like user management, gender, age, race, visit type, charge type, department, sample type, dilution ratio, mark, etc. on the "Management" interface.

Note

- Only users with administrator permission are accessible to the management interface.
 - Reagent replenishment can only be performed in the standby state.
-

11.1 Reagent management

Click "Management" on the main interface to directly enter the reagent management interface. On the "Reagent management" interface, you can view reagent residual, sheath fluid replenishment, strip replenishment, query reagent consumption information, view replenishment records and set reagent residual reminder.

- Sheath fluid replenishment
In the reagent information column, click "CPU card replenish", and a dialog "Insert CPU card into the card reader!" will pop up. Insert the CPU card for sheath fluid into the computer card reader according to the prompt, and then click "Confirm". After replenishing, the residual and use-by date will be displayed in the current reagent information list.
- Strip replenishment
In the reagent information column, click "Strip replenish", and the barcode information dialog will pop up. After entering the barcode number, click "Confirm" to replenish, and the residual and use-by date will be displayed in the current reagent information list.
- Query of reagent consumption information
You may view the reagent consumption per "Today" or per "By date".
- Set reagent residual reminder
You may set the warning value for sheath fluid or strip residual.
- Reagent replenishment record
You may query reagent replenishment records per "This year", per "This month" or per "By date".

11.2 User management

On the "Management" interface, click "User management" to enter the user management interface.

- Adding a new user
 - (1) The user name, permission and password of the new user can be set in the input box on the right of the user management interface;
-
-

Management

- (2) You may enter the user's name in the input box after the User name, however inside the name input box;
 - (3) Enter the mnemonic symbols for the user name in the input box after the Mnemonic symbols;
 - (4) In the input box after Permission, the user can select the permission, which may be: administrator, operator or viewer. Of which the viewer only has the permission of data query; The operator is provided with all test and edit capacities, but does not have system management or system setup permissions; The administrator is permitted to all test, edit and setup capacities of the software (including system management, system setup and user management);
 - (5) Enter and set the login passwords in the input box after Password and Confirmation respectively. The two login passwords must be consistent;
 - (6) Click "Add", the dialog of "Added!" will pop up, and then click "Confirm" to complete the new user addition.
- Deleting the user
 - (1) On the "User management" interface, select an operator to be deleted, and click "Delete" to prompt a dialog "Deleting selected {0} pieces of data?";
 - (2) Click "Confirm" and the selected user will be deleted; If you click "Cancel", the user will be remained.
-

Note

The default administrator of the system is permitted to add, modify and delete other users, but not permitted to delete its own account.

- Modifying the user
 - (1) After selecting one piece of user information on the "User management", and you may modify the user name, mnemonic symbols, permission or password;
 - (2) Click "Modify", and the "Modified!" dialog will pop up. Click "Confirm" to complete the modification.

11.3 Gender

On the "Management" interface, click "Gender" to enter the "Gender" interface.

- Adding the gender
 - (1) Enter the added gender in the Gender input box on the right;
 - (2) Enter the mnemonic symbols for the added gender in the input box after the mnemonic symbols;
 - (3) Click "Add", and the dialog "Added!" will pop up;
 - (4) Click "Confirm" and the added contents will be included in the gender list.
 - Modifying the gender
 - (1) Select the item to be modified in the gender list, and enter the modified content in the input box after the corresponding item on the right;
 - (2) Click "Modify" to pop up the dialog box of "Modified!", and click "Confirm" to save the modified contents.
 - Deleting the gender
 - (1) Select the item to be deleted in the gender list, click "Delete", and the dialog box "Deleting selected {0} pieces of data?" will pop up;
 - (2) Click "Confirm" to delete the selected item; Or click "Cancel" to remain the
-

original settings.

11.4 Age unit

On the "Management" interface, click "Age unit" to enter the age unit interface.

- Adding the age unit
 - (1) Enter the unit of the added age in the input box on the right of the age unit interface;
 - (2) Enter the mnemonic symbols for the added age unit in the input box after the mnemonic symbols;
 - (3) Click "Add", and the dialog "Added!" will pop up;
 - (4) Click "Confirm", and the added contents will be included in the age unit list and arranged in the last row corresponding to its sequence number.
- Modifying the age unit
 - (1) Select the item to be modified in the age unit list, and enter the modified content in the input box after the corresponding item on the right;
 - (2) Click "Modify" to pop up the dialog box of "Modified!", and click "Confirm" to save the modified contents.
- Deleting then age unit
 - (1) Select the item to be deleted in the age unit list, and click "Delete";
 - (2) The dialog "Deleting selected {0} pieces of data?" pops up. Click "Confirm" to delete the selected item; Or click "Cancel" to remain this setting.

Note

The default age unit in the list is year, year old, month and day, and the mnemonic symbols by default is the full spelling of the age unit.

11.5 Race

On the "Management" interface, click "Race" to enter the "Race" interface.

- Adding a race
 - (1) Enter the race in the input box on the right side of the "Race" interface;
 - (2) Enter the mnemonic symbols for the added race in the input box after the mnemonic symbols;
 - (3) Click "Add", and the dialog "Added!" will pop up;
 - (4) Click "Confirm", and the added contents will be included in the race list and arranged in the last row corresponding to its sequence number.
- Modifying the race
 - (1) Select the item to be modified in the race list, and enter the modified contents in the input box after the corresponding item on the right;
 - (2) Click "Modify" to pop up the dialog box of "Modified!", and click "Confirm" to save the modified contents.
- Deleting the Race
 - (1) Select the item to be deleted in the race list, click Delete, and the dialog box "Deleting selected {0} pieces of data?" will pop up;
 - (2) Click "Confirm" to delete the selected item; Or click "Cancel" to remain the original settings.

11.6 Visit type

Management

On the "Management" interface, click the "Visit type" to enter the "Visit type" interface.

- Adding a visit type
 - (1) Enter the visit type to be added in the input box on the right of the "Visit type" interface;
 - (2) Enter the mnemonics symbols for the added type of visit in the input box after the mnemonics symbols;
 - (3) Click "Add", and the dialog "Added!" will pop up;
 - (4) Click "Confirm", and the added contents will be included in the visit type list and arranged in the last row corresponding to its sequence number.
 - Modifying the visit type
 - (1) Select the item to be modified in the visit type list, and enter the modified content in the input box after the corresponding item on the right;
 - (2) Click "Modify", and the dialog "Modified! " will pop up. Click "Confirm" to save the modified contents.
 - Deleting the visit type
 - (1) Select the item to be deleted in the visit type list. Click "Delete" and the dialog "Deleting selected {0} pieces of data?" will pop up;
 - (2) Click "Confirm" to delete the selected item; Or click "Cancel" to remain the original settings.
-

Note

There are two default settings in the list, Outpatient and Inpatient, and mnemonics symbols default to the initials of the name in pinyin.

11.7 Charge type

On the "Management" interface, click "Charge type" enter the "Charge type" interface.

- Adding a charge type
 - (1) Enter the charge type to be added in the right input box;
 - (2) Enter the mnemonics symbols for the added charge type in the input box after the mnemonics symbols, click "Add", and the dialog "Added!" will pop up;
 - (3) Click "Confirm", and the added contents will be included in the charge type list and arranged in the last row corresponding to its sequence number.
 - Modifying the charge type
 - (1) Select the item to be modified in the charge type list, and enter the modified content in the input box after the corresponding item on the right;
 - (2) Click "Modify" to pop up the dialog box of "Modified!", and click OK to save the modified contents;
 - Deleting the charge type
 - (1) Select the item to be deleted in the charge type list, click "Delete", and the dialog "Deleting selected {0} pieces of data?" will pop up;
 - (2) Click "Confirm" to delete the selected item; or click "Cancel" to remain the original settings.
-

Note

There are two default settings in the list, Out-of-Pocket and Medical Insurance. The mnemonics symbols default to the initials of the name in pinyin.

11.8 Delivery department & doctor

On the "Management" interface, click "Delivery department & doctor" to enter the corresponding interface.

11.8.1 Delivery department

This section mainly introduces the main information of the delivery department settings, including the addition, modification and deletion of the delivery department.

- Adding a department
 - (1) The delivery department settings are on the left side of the "Delivery department & doctor" interface, and the name of the added delivery department can be entered in the input box below;
 - (2) Enter the mnemonic symbols for the added department in the input box after the mnemonic symbols, click "Add", and the dialog "Added!" will pop up;
 - (3) Click "Confirm", and the added contents will be included in the department list and arranged in the last row corresponding to its sequence number.
- Modifying the department
 - (1) Select the item to be modified in the department list, and enter the modified content in the input box after the corresponding item on the right;
 - (2) Click "Modify" to pop up the dialog box of "Modified!", and click "Confirm" to save the modified contents.
- Deleting then department
 - (1) Select the item to be deleted in the department list, click "Delete", and the dialog "Delivery doctor will be deleted together with department, delete selected data?" will pop up;
 - (2) Click "Confirm" to delete the selected item and the doctors contained in the selected item; or click "Cancel" to remain the original settings.

11.8.2 Delivery doctor

This section mainly introduces the main information of the doctor, including the addition, modification and deletion of the doctor.

- Adding a doctor
 - (1) The delivery doctor settings are on the right side of the "Delivery department & doctor" interface. Enter the name of the submitter in the input box below, and enter the added mnemonic symbols for the submitter in the input box after the mnemonic symbols;
 - (2) Click "Add", and the dialog "Added! " will pop up;
 - (3) Click "Confirm", and the added contents will be included in the doctor list and arranged in the last row corresponding to its sequence number.

Likewise, add the names of doctors of other departments and their mnemonic symbols.

- Modifying the doctor
 - (1) Select the item to be modified in the doctor list, and enter the modified content in the input box after the corresponding item on the right;
 - (2) Click "Modify" to pop up the dialog box of "Modified!", and click "Confirm" to save the modified contents.
 - Deleting the doctor
 - (1) Select the item to be deleted in the doctor list, click "Delete", and the dialog "Deleting selected {0} pieces of data?" will pop up;
 - (2) Click "Confirm" to delete the selected item; or click "Cancel" to remain the original settings.
-

11.9 Dilution ratio

On the "Management" interface, click Dilution ratio to enter the "Dilution ratio" interface.

- Adding a dilution ratio
 - (1) Enter the dilution ratio to be added in the right input box, and enter the added dilution ratio mnemonic symbols in the input box after the mnemonic symbols;
 - (2) Click "Add", and the dialog "Added!" will pop up;
 - (3) Click "Confirm", and the added content will be included in the dilution ratio list and arranged in the last row corresponding to its sequence number.
- Modifying the dilution ratio
 - (1) Select the item to be modified in the dilution ratio list, and enter the modified content in the input box after the corresponding item on the right;
 - (2) Click "Modify" to pop up the dialog box of "Modified!", and click "Confirm" to save the modified contents.
- Deleting the dilution ratio
 - (1) Select the item to be deleted in the dilution ratio list, and click "Delete" to pop up the dialog "Deleting selected {0} pieces of data?";
 - (2) Click "Confirm" to delete the selected item; or click "Cancel" to remain the original settings.

11.10 Abnormal mark

On the "Management" interface, click "Abnormal mark" to enter the abnormal mark interface.

- Adding an Abnormal Mark
 - (1) Enter the abnormal mark to be added in the right input box, and enter the mnemonic symbols for the added abnormal mark in the input box after the mnemonic symbols;
 - (2) Click "Add", and the dialog "Added!" will pop up;
 - (3) Click "Confirm", and the added content will be included in the abnormal mark list and arranged in the last row corresponding to its sequence number.
- Modifying the mark
 - (1) Select the item to be modified in the mark list, and enter the modified content in the input box after the corresponding item on the right;
 - (2) Click "Modify" to pop up the dialog box of "Modified!", and click "Confirm" to save the modified contents.
- Deleting the mark
 - (1) Select the item to be deleted in the mark list, click "Delete", and the dialog "Deleting selected {0} pieces of data?" will pop up;
 - (2) Click "Confirm" to delete the selected item; or click "Cancel" to remain the original settings.

12 Settings

This chapter mainly introduces how to setup the instrument, including system configuration, morphology configuration, dry chemical configuration, re-examination rules, auto printing, automatically send to LIS, auto review and so on.

12.1 System configuration

Click the "Settings" on the main interface of the software to enter the "System configuration" interface.

12.1.1 Set language

Select the language in the language setting area of the "System configuration" interface.

For example: click the drop-down box of "Language", select "English" and then click "Save" at the bottom of the screen. Then the language in other interfaces will be shifted to English.

12.1.2 Set result decimal precision

In the "System configuration", you can set the decimal precision of the result, for example, enter 2 for decimal places, click "Save" at the bottom of the screen, and it will jump to the sample result interface, where you can see the results with two decimal places.

12.1.3 Device setting

In the "Device setting" box of the "System configuration" interface, the serial port number to be set should be the serial number for the communication between the instrument and the computer. This can be set by the user as appropriate.

12.1.4 Device temperature alarm range

The temperature range should be set within the alarm range of the instrument temperature (10 ~ 30°C by default). In case the ambient temperature exceeds this range, a prompt alarm will be given.

12.1.5 PHYC unit setting

The user can set the PHYC unit on the "System configuration" interface. Select SG (if the PHYC unit is configured) to enable specific gravity components and test results. Select turbidity (if the PHYC unit is configured), and enable turbidity components and test results. Select color (if the PHYC unit is configured) to enable the color components and test results. Select conductivity (if the PHYC unit is configured) to enable the conductivity components and test results.

12.1.6 Reagent expiration range prompt

Set the prompt of reagent expiration range, so that the user can be prompted when the reagent expiration is shorter than the set range.

12.1.7 Alarm

When the instrument gives an alarm, if a buzzer prompt is needed in addition to the flashing alarm icon, select "On" in the alarm tone of the "System configuration", so that there will be

Settings

double prompts when the system alarms.

If "No tube rack in the area to be tested" is selected, a prompt will be given when there is no tube rack in the pending test area during the test. Cancel the selection if it is not required.

12.1.8 Test mode

The test mode can be set on the "System configuration" interface: when "Manual" is selected, the sample number is allowed to be edited manually when sending the test; when "Automatic" is selected, the sample number is the "current maximum sample number +1" by default when sending the test, and not allowed to be modified.

12.1.9 Set manual review

Check "Name" after the review conditions. When performing manual review on the "Sample test" > "Test result" screen, it is necessary to identify whether "Sample info." > "Name" is blank. If it is blank, the review result will be "Fail", and a prompt will pop up in the upper right corner of the Main Interface. If it is not checked, no judgment will be made.

Check "Barcode" after the review conditions. When performing manual review on the "Sample test" > "Test result" screen, it is necessary to identify whether the "Sample info." > "Barcode" is blank. If it is blank, the review result will be "Fail", and a prompt will pop up in the upper right corner of the main interface. If it is not checked, no judgment will be made.

12.1.10 Set sleeping time

Check "Enable" and select the sleep time from the drop-down menu on the right side of "Sleep time", then the instrument will enter sleep state after the selected time.

12.1.11 Abnormal mark

The abnormal mark can be set on the "Settings" interface. In the "Set abnormal mark" area, click the drop-down box of the "Abnormal mark", select the required mark, click "Save", and the selected mark will be displayed on the test report if the test result is abnormal.

12.1.12 LIS configuration

If the instrument is connected with other LIS, LIS configuration should be made.

LIS configuration is connected via the network:

- Select "LIS network port" in the "System configuration", simultaneously selecting the "Automatic connection to LIS server when software starts", and then the connection of LIS network port will automatically be enabled at startup.
- IP address: refers to the IP address of the server in the LIS.
- Port number: refers to the port number of the server in the LIS.

LIS configuration is connected via the serial port:

- Select the option "Auto connect to LIS server when running software" in the "System configuration" and then the serial port connection of LIS will automatically be enabled when the software starts.
- Serial port No.: select the communication serial port number. The user may set it as appropriate.
- Data bits, stop bits and parity check are all default values, which cannot be modified by users. But users are allowed to modify the baud rate.

12.2 Morphological configuration

Click "Morphology configuration" on the "Settings" interface to enter the "Morphology

configuration" interface.

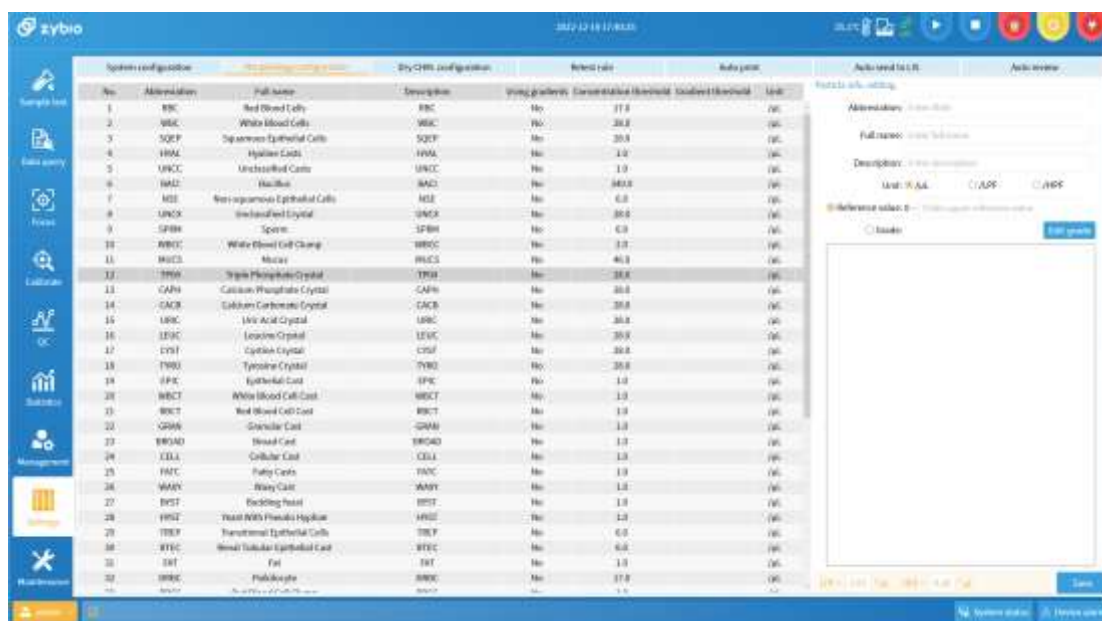

Figure 12-1 Morphology configuration interface

- Particle information editing

After selecting the item to be edited in the list box on the "Morphology configuration", enter the corresponding information in the right particle information editing box:

- Abbreviation: enter the abbreviation of this item in the printed report (either texts or numbers are OK).
- Full name: enter the name of the item (either texts or numbers are OK).
- Description: enter the description of this item.
- Unit: check the commonly used unit.

If reference value is used, please edit the upper limit of reference value in the reference value input box.

If this item is graded, check the radio box before Grade.

- Edit grade

Click "Edit grade" in the "Morphology configuration" to enter the "Edit grade" interface, and the sediment grading setup interface will be displayed. (Any starting value and its corresponding user-defined grade name can be edited according to the reference value range)

- Adding a grade: click "Add" after entering the starting value and grade name, and then the new content will be shown in the grade edit list.
- Modifying the grade: select a grade, modify its starting value position and grade name position in turn, and click "Modify" to show the modified contents in the list.
- Deleting the grade: select a record in the list and click "Delete", and then the dialog "Delete grade?" will pop up. Click "Confirm" to delete it, or Click "Cancel" to not delete the content.

12.3 Dry Chemical Configuration

Click "Dry CHM. configuration" on "Setting" interface to enter the "Dry CHM. configuration" interface.

Settings

Edit the unit system and negative expression of the dry chemical part on the "Dry CHM. configuration" interface (this function is limited to the administrator).

- Unit systems: there are three systems of units including international system (IS), conventional system, and symbolic system of units. They are divided into the following combination check methods. Users may check the following unit forms based on needs:
 - Check "International" only.
 - Check both "International" and "Using plus system".
 - Check "Conventional" only.
 - Check both "Conventional" and "Using plus system".
 - Check "Symbol".
 - Negative representation: Neg and –.
-

Note

There are 3 types of dry chemical strips: 11 items, 12 items, and 14 items. If changing the strip type is required, please contact Zybio.

12.4 Re-examination rule

Click "Retest rule" on the "Setting" interface to enter the re-examination rule setting interface.

12.4.1 Microscopic examination condition

This section mainly introduces the main operations about microscopic examination condition, as follows:

- Adding a microscopic examination condition: click "Add" on the "Microscopy condition" on the left side of the "Retest rule", that is, a new row will be added to the microscopic examination conditions table. When clicking a cell, the drop-down box options for this item will be shown, for example: Select RBC+ and click "Save" to add a set of microscopic examination judgment conditions.
 - Delete: in case there is no need to set the microscopic examination conditions or urine culture conditions, they can be deleted. Click the line in the list box where the microscopic examination conditions are located, and then click "Delete".
 - Restore default: click "Restore default", and click "Confirm" in the pop-up dialog box to restore the microscopic examination condition information to default.
-

Note

After the microscopic examination conditions are deleted, there will be no prompt no matter what the test results are, and the manual microscopic examination should be performed.

12.4.2 Urine culture conditions

Urinary tract infection is caused by direct invasion of bacteria (in a few cases invaded by fungi, protozoa and viruses).

Urinary tract infection is divided into upper urinary tract infection and lower urinary tract infection. Upper urinary tract infection refers to pyelonephritis, and lower urinary tract infection includes urethritis and cystitis. Pyelonephritis, consisting of acute pyelonephritis and chronic pyelonephritis, is more common in women. Items like red blood cells, white blood cells or proteins may be included in routine urine examination, so the instrument can

provide rapid screening report for urinary tract infection. As shown in the table below, urine culture examination is recommended if the prompt conditions of urinary tract infection are met.

Table 12-1 Prompt conditions of urinary tract infection

Item \ Conditions	1	2	3	4	5	6
RBC (sediment)	-	+	-	-	-	+
BLD (dry chemical)	-	+	+	+	+	+
WBC (sediment)	+	+	+	-	+	-
WBC (dry chemical)	-	+	-	-	-	-
NIT (dry chemical)	+	+	+	+	+	+
BACT (sediment)	+	-	-	+	+	-

- Add: click "Add" to add a new row in the urine culture condition table. Click a cell to show the drop-down box options for this item, for example: Select RBC+ and click "Save" to add a set of urine culture judgment conditions.
- Delete: if urine culture conditions do not need to be set, click on the cell where the urine culture judgment conditions are located to delete it.
- Restore default: click "Restore default", and click "Confirm" in the pop-up dialog box to restore the microscopic examination condition information to default.

Note

Once the urine culture conditions are deleted, there will be no prompt no matter what the test results are.

12.5 Auto print

Click "Auto print" on the "Settings" interface to enter the "Auto print" interface.

On the "Auto print" interface, the user can set the dry chemical and morphological conditions for automatic printing, which may be enabled separately or simultaneously. Either or both of them is allowed to be enabled.

- On the left side of the interface is the condition "Auto print Dry CHM. results when meet following conditions" and on the right side is the condition "Auto print morphology results when meet following conditions". Right after each item, the user can modify the conditions by selecting a drop-down box option. After modification, check "Enable function" or "Reviewed". Click "Save" to automatically print the qualified test results.
- When NONE is selected for all conditions, unconditional automatic printing will be performed.
- Cancel the selection of "Enable function" if automatic printing is not needed. At this time, no matter what conditions the results meet, automatic printing will not be performed.
- To modify the print template, click "Set print" on "Auto print" interface to change or customize the print template.

12.6 Auto send to LIS

Click "Auto send to LIS" on the "Settings" interface to enter the "Auto send to LIS" interface.

On the "Auto send to LIS" interface, the user can set the conditions for performing automatic sending to LIS in dry chemical or morphology that may be enabled separately or simultaneously.

- On the left side of the interface is the condition "Auto send to LIS when Dry CHM. Results meet following conditions" and on the right side is the condition "Auto send to LIS when morphology results meet following conditions". Right after each item, you can modify the conditions by selecting a drop-down box option, check "Enable function" after modification, and click "Save" to automatically send the qualified test results to LIS.
- When NONE is selected for all conditions, unconditional automatic sending to LIS will be performed.
- If auto send to LIS is not needed, cancel the selection of "Enable function", and the automatic sending to the LIS will not be performed no matter what conditions the results meet.

12.7 Auto review

Click "Auto review" on the "Setting" interface to enter the "Auto review" interface.

On the "Auto review" interface, the user can set the conditions for performing automatic review, in dry chemical or morphology that may be enabled separately or simultaneously.

- On the left side of the interface is the condition "Perform auto review when Dry CHM. Results meet following conditions" and on the right side is the condition "Auto review performed when morphology results meet the following conditions". Right after each item, the user can modify the conditions by selecting a drop-down box option. After modification, check "Enable function" or check "Barcode" and "Name". Click "Save" to automatically review the qualified test results.
- When NONE is selected for all conditions, unconditional auto review will be performed.
- Cancel the selection of "Enable function" if auto review is not needed. At this time, no matter what conditions the results meet, auto review will not be performed.

13 Maintenance

Click "Maintenance" on the left side of the main interface, and the user can perform operations such as priming the fluidics, replacing sheath fluid, gray adjustment, emptying, cleaning the flow cell, cleaning the fluidics, cleaning physicochemical unit, blank test, database backup, database recovery, and data clearing.

13.1 Replace sheath fluid

When there is no sheath fluid in both the buffer bottle and the container, remove the empty container connected to the instrument at the back, replace it with a new sheath fluid container, and connect with the instrument. Click "Replace sheath fluid", and the instrument will perform the replacement operation to re-prime the tubing with sheath fluid.

13.2 Prime sheath fluid

When there are air bubbles in the tubing or replacing the sheath fluid, click "Prime fluidics" in the Maintenance, and the bubbles in each tubing will be discharged, so as to avoid the influence of bubbles on the test results.

Note

- Before stopping using the instrument, first empty the fluidics, then prime the fluidics with distilled water for multiple times, and finally empty the fluidics again.
- When the instrument is not used for a period of time, prime the fluidics prior to using it again.

13.3 Gray

When the focus fault occurs in the instrument, it is used to guide after-sales engineers to repair and debug.

13.4 Empty

Before the system transports for analysis, empty the fluidics first.

- (1) Click "Empty" on the "Maintenance" interface, and then "Empty sheath fluid buffer bottle, plug sheath fluid tube out from sheath fluid container, then click 'Confirm' when finished" will pop up. Do as prompted and then click "Confirm". Pull out the sheath fluid supply tubing interface and sensor plug at the back of the instrument;
- (2) Click "Confirm" in the software prompt box to start the emptying operation.

Note

- When emptying fluidics, do not unplug the waste liquid tubing interface and the waste liquid sensor plug. When the instrument is in the Standby state after emptying, remove the waste liquid tubing interface and the waste liquid sensor plug.
-
-

Maintenance

- Before moving the instrument, please split it into two parts: the instrument and the rack-in module.
-

Before stopping using the instrument, first empty the fluidics, then prime the fluidics with distilled water for multiple times (just replace the sheath fluid in the sheath fluid bottle with distilled water), and finally empty the fluidics again.

Note

Before emptying the fluidics, the sheath fluid tube should be separated from the instrument interface.

13.5 Clean flow pool

To prevent the residual artifact in the flow pool from affecting the accuracy of the test results, the flow cell should be cleaned once a day. The cleaning method is as follows:

- (1) Fill the test tube with about 3.5 mL of wash solution, put it at the first position of the tube rack, and then put the tube rack on the right side of the rack-in module;
- (2) Click "Clean flow pool" on the "Maintenance" interface, and the test tube rack will be automatically pushed to the sample aspiration position, where the sample probe will aspirate about 2 mL of wash solution. After soaking the flow cell for about 3 minutes, repeat the operation of cleaning the flow cell.

13.6 Clean fluidics

When there are air bubbles in the wash solution tubing or the instrument alarms "Clean fluidics", click "Clean fluidics" on the "Maintenance" interface, and the bubbles in the wash solution tubing will be discharged, so as to avoid the influence of bubbles on the test results.

13.7 Clean physicochemical unit

Note: PHYC unit includes conductivity and specific gravity. As the conductivity, specific gravity, and turbidity are in the same loop in the fluidics system, they can be cleaned at the same time and in the same step.

To avoid the residual artifact in the physicochemical unit affecting the accuracy of the test results of the instrument, it is necessary to clean the physicochemical unit when the calibration specific gravity, turbidity and conductivity fail. The cleaning method is as follows:

- (1) Fill the test tube with about 3.5 mL of wash solution, put it at the first position of the tube rack, and then put the tube rack on the right side of the rack-in module.
- (2) Click "Cleaning PHYC unit" on the "Maintenance" interface, and the tube rack will be automatically pushed to the sample aspiration position, and the sample probe will aspirate about 2 mL of wash solution. After soaking the physicochemical unit for about 3 minutes, repeat the cleaning operation of it.

13.8 Blank test

When the startup blank test of the instrument fails or the instrument is in maintenance, click "Blank test" on the "Maintenance" interface to perform the blank test.

- Once the blank test passed, the information that prompts the blank test passed will be displayed.
 - In case the blank test fails, the information that prompts the blank test passed will be displayed. At this time, the operations of "Clean fluidics" and "Clean flow pool" should
-
-

be repeated. If it still fails, please contact customer service.

13.9 Clear data

Click "Clear data" and select the data type to be cleared in the pop-up window. Click "Confirm" to clear it.

13.10 Database backup and recovery

The instrument has the function of data backup, permitting operations of backup reminder setup and backup path setup of the database.

Note

Users are recommended to back up the database regularly to prevent data loss caused by unexpected circumstances. Backup and restore the database in standby mode.

- Auto backup reminder of database
Click "Database backup" on the "Maintenance" interface, select manual backup or set the time of scheduled backup.
- Backup path of database
The default path is in drive E. Click "Database backup" to set the backup path.
- Database recovery
In case of any data loss for some reasons, the user can use the backed-up database file to restore the previous data.
Click "Database recovery" on the "Maintenance" interface to open next interface. Select the backed-up file and click "Open". When the dialog "Database recovered" pops up, click "Confirm".
- Clearing Data
Click "Clear data" on the "Maintenance" interface, and the prompt box will pop up, as shown in Figure 13-3. Check the items to be cleared and click Delete. When the prompt box of "Data cannot be recovered if deleted, delete it now?" pops up, click "Confirm" to clear the data.

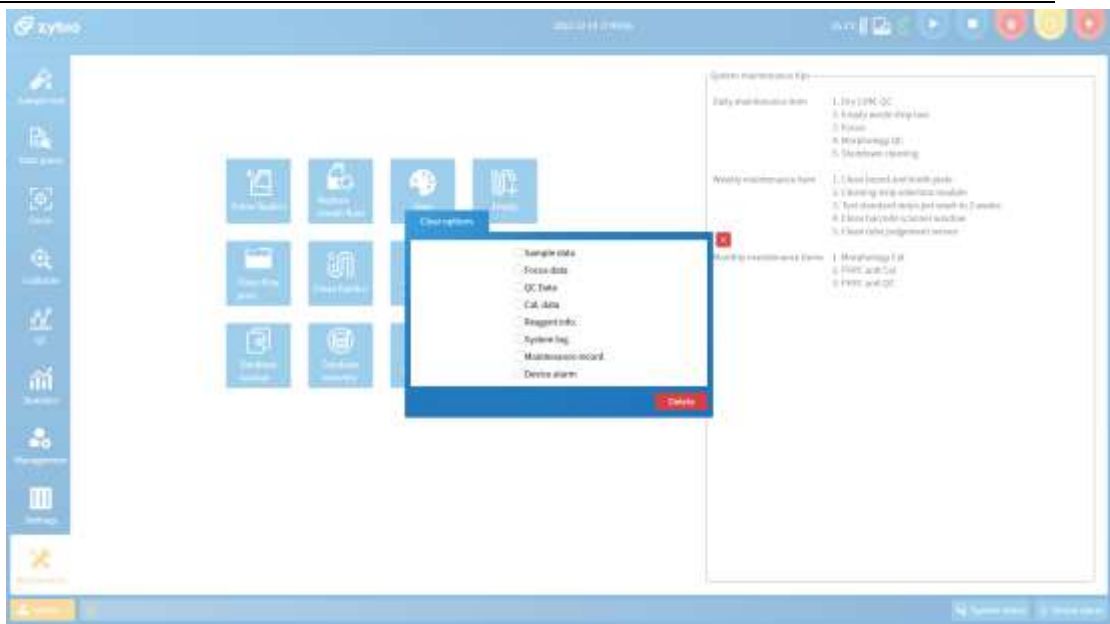

Figure 13-1 Clear options interface

14 Maintenance and care

To ensure the accuracy and precision of the instrument, the operator must strictly follow the requirements of this manual and regularly maintain the instrument. Only in this way can the instrument provide reliable results and ensure its service life.

Warning

- Do not spill water, reagents, sheath fluid and other liquids on the mechanical or electrical parts of the instrument, so as to avoid damage to the instrument.
- When the instrument is running, do not touch the sample probe, otherwise there is a risk of infection or injury.
- When using the instrument, operators should take preventive measures, such as wearing gloves, masks, protective glasses and overalls. Otherwise, infection may be caused due to contact with the contaminated areas and liquids, or skins may be damaged by contact with corrosive liquids. If the body contacts the contaminated or corrosive liquid accidentally, washing with water and immediate disinfection is required.
- If the accessories used in the instrument are not provided or recommended by the manufacturer, or the instrument is not used in the way specified by the manufacturer, the protection provided by the instrument may be weakened.
- During maintenance, attentions should be paid to finding potential dangers caused by the failure of any hose or parts containing liquid.

Note

- Before stopping using the instrument, first empty the fluidics, then prime the fluidics with distilled water for multiple times, and finally empty the fluidics again.
 - When the instrument is not used for a period of time, prime fluidics prior to using it again.
-

Before maintaining the instrument, please prepare the following tools: cotton swab, gauze.

14.1 Clean the waste strip box

This section mainly introduces the method of cleaning the waste strip box and cautions when cleaning.

Note

A waste test strip box can hold up to about 300 test strips and should be cleaned once a week.



- Urine is potentially infectious. Protective measures must be taken when cleaning.
 - Please dispose of the discarded test strips in accordance with the clinical laboratory regulations.
-

The method of cleaning a waste strip box is as follows:

- (1) Take out the waste strip box as shown in the figure below, and discard the test strips inside the waste strip box;
- (2) Rinse the waste strip box with pure water;
- (3) Wipe or air-dry the waste strip box;
- (4) Install the cleaned waste strip box to the original position.

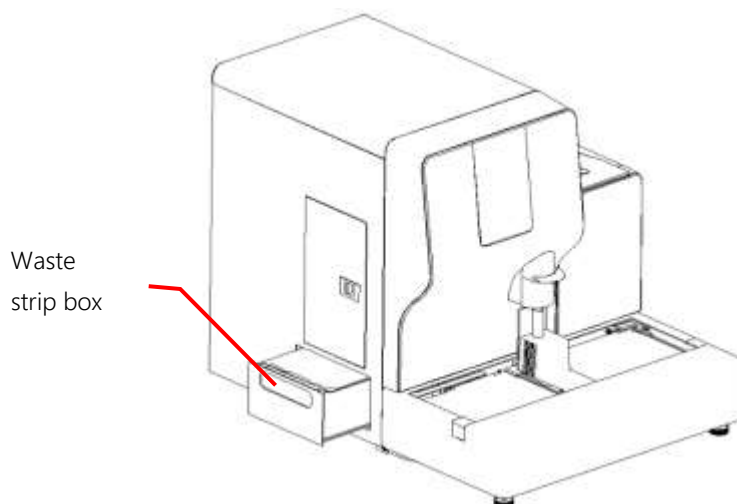

Figure 14-1 Ways to take out the waste strip box

14.2 Clean the strip-transport plate

To ensure the cleanness of the bedplate, the bedplate and the strip-transport toothed plates should be cleaned at the end of each weekly test. The method is as follows:

Step 1: Press the button on the strip-pick cover **①** to open the strip-pick cover **②**, press the button **③**, and open the front hood component **④**.

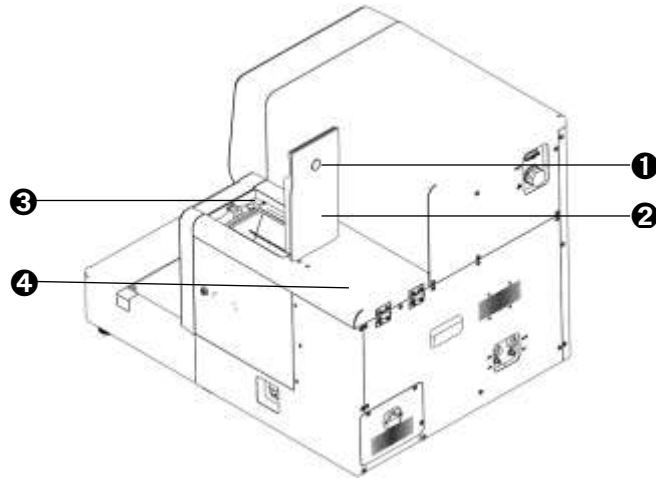

Figure 14-2 Clean the strip-transport plate - step 1

Step 2: Use the small door key to open the latch ⑥ on the right door component ⑤, and then the component is opened.

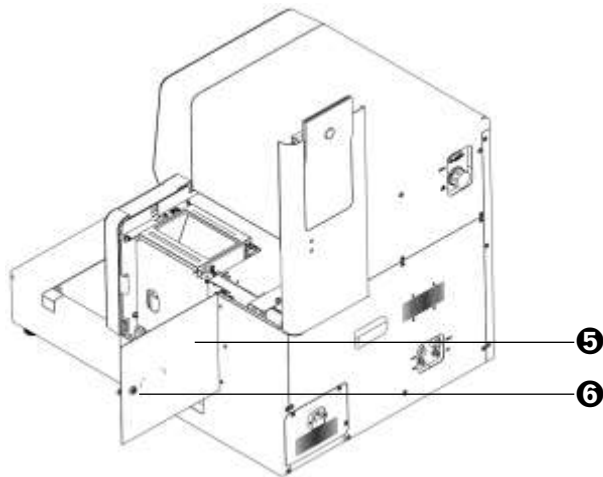

Figure 14-3 Clean the strip-transport plate - step 2

Step 3: Turn the strip-pick module ⑦ outward.

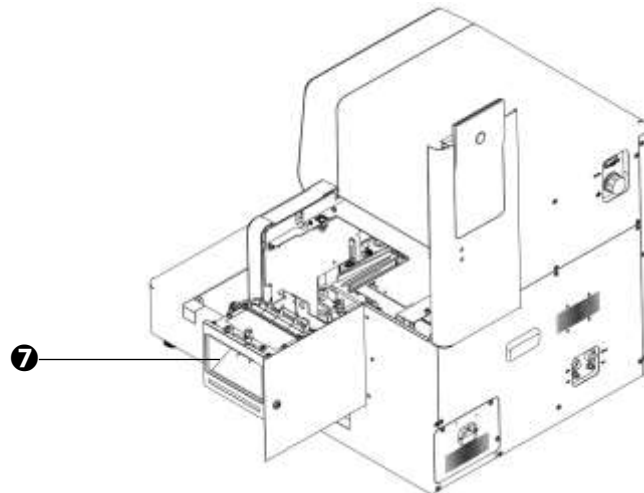

Figure 14-4 Clean the strip-transport plate - step 3

Step 4: Use your thumb to withhold the clasp **9** on the bedplate **8**, and use your forefinger to press against the right strip-pick plate **10** to remove the bedplate downward.

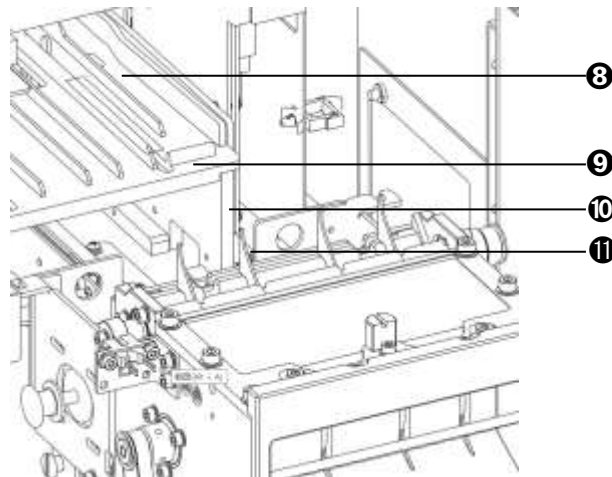

Figure 14-5 Clean the strip-transport plate - step 4

Step 5: Remove the toothed plate **12** upward.

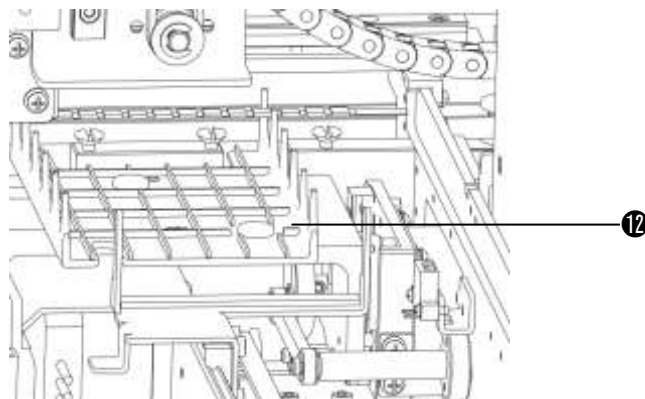

Figure 14-6 Clean the strip-transport plate - step 5

Note

When removing the bedplate, do not touch the strip-pick bar **11** to avoid injury.

Step 6: Wipe the paper scraps of the strip-pick module with a small brush, wipe the bedplate and the toothed plate with gauze dipped with alcohol, then wash the bedplate with pure water, and put it at the vent. After the bedplate is dried, install it to its original position, and restore the instrument in a sequence from Step 5 to Step 1.

14.3 Clean waste liquid container

When cleaning the waste liquid container, the following should be noted:

- Dispose the waste liquid in strict accordance to clinical laboratory regulations.
- Clean the waste liquid container once a week.
- Pour out the waste liquid in time when the waste liquid container is full.
- Urine is potentially infectious, and protective measures must be taken when cleaning.

14.4 Clean the scanning window of the barcode scanner

The barcode scanner is located at the front of the emergency baffle of the rack-in module. To avoid the misreading or no reading of the barcode due to stains or dust on the scanning window, it is recommended to clean the scanning window once a week.

Cleaning method: dip the cotton swab with 2% alkaline or neutral glutaraldehyde solution or 0.5% chlorhexidine acetate-ethanol solution barcode scanner window.

14.5 Clean the sensor

The sensor that detecting if there is tube is located at the baffle in front of the barcode scanner of the rack-in module. To avoid the misjudgment due to dust on the surface of the sensor, it is recommended to clean the sensor once a month.

Cleaning method: wipe the sensing surface of the sensor with dry and clean cotton swab.

14.6 Clean sheath fluid bottle

After long-term storage, the sheath fluid in the sheath fluid bottle will form a layer of fouling on the bottle wall, which will affect the quality of the sheath fluid and even the test results. Therefore, the sheath fluid bottle should be cleaned once a month. The cleaning method is as follows:

- (1) Exit the software and turn off the power switch of the instrument;
- (2) Open the small door on the right side of the instrument, unscrew the cap component, and remove the sheath fluid bottle;
- (3) Use clean self-sealing bag or plastic film to seal the bottle cap component and avoid tubing contamination;
- (4) Pour out the remaining sheath fluid from the bottle, and clean the bottle with deionized water;
- (5) After cleaning, screw the bottle back into the cap component, lock the cap, put the sheath fluid bottle back in place and close the small door.

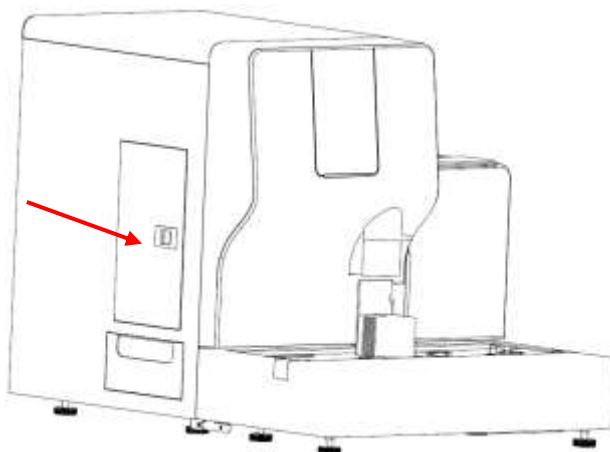

Figure 14-7 Cleaning sheath fluid bottle

Note

Do not drag the tubing or harness forcibly.

14.7 Empty fluidics

When the instrument is not used for more than one week, the liquid in the whole instrument tubing should be emptied, so as to prevent crystallization and ensure the testing accuracy of the instrument.

- (1) Refer to Section 13.4, click "Empty" to empty all liquid in the tubing of the instrument;
- (2) Insert the sheath fluid tube into the deionized water bucket, click Clean to clean the fluidics again with deionized water and ensure that there will be no residual reagent in the tubing;
- (3) After cleaning, pull out the sheath fluid tube from the deionized water, click Empty again and empty the deionized water in the instrument. Then turn off the power supply and complete the maintenance process.

14.8 Check and replace the tubing

Please be aware of the followings when checking and replacing the tubing of the instrument:

- In the process of using the instrument, ensure that the reagent tubing (e.g., sheath fluid, liquid waste) is not kinked or weighted by heavy objects.
- During operating the instrument, if the dry strip error or full waste container error occurs while there is sufficient wash solution in the external container and enough sample in the tube, please check if the tubing leaks or poorly connected. If the leakage or poor connection is arising from bent or knikled tubing, please adjust the tubing and click Reset on the interface. If it is caused by aging or wearing of the tubing, stop operating the instrument and contact Zybio timely.

14.9 Replacement of wearing parts

The information of wearing parts of the instrument is shown in the table below:

Table 14-1 Information of wearing parts

No.	Part name	Replacement cycle	Replacement method
1	Injection pump	After damage or 12 months	Contact Zybio or the local distributor for replacement.
2	Fuse	After damage	Replace by users.

Fuse replacement

Two T6.3AH250V fuses are contained to protect the instrument. If the fuse is blown, replace the fuse following the steps below:

- (1) Power off the instrument and unplug the power cord;
- (2) Open the fuse holder with a slotted screwdriver, take out the fuse, and replace with a new one;
- (3) Close the fuse holder.

Warning

- For the performance and safety of the instrument, all the maintenance spare parts above shall be purchased from the manufacturer or the authorized local distributor.
- All parts other than the fuse shall be replaced by manufacturer or the authorized local distributor. Otherwise, the user shall assume all the responsibilities.

14.10 Error information and troubleshooting

During the use of the instrument, in case an abnormal condition is detected, the instrument will display the corresponding fault prompt information. For easy search, this section will list all possible fault information displayed by the instrument, and provide possible causes and troubleshooting steps. Operators may refer to the provided steps for troubleshooting.

Table 14-2 Instrument error information and troubleshooting

Error code	Error type	Error information	Possible causes	Solutions
0x0103	Stop level	Probe fails to leave from cleaning position OC.	<ol style="list-style-type: none"> 1. Probe motor OC. damaged. 2. Probe motor OC. drive chip damaged. 3. Probe motor OC. lost step. 4. The probe component is abnormally stuck during operation. 	<ol style="list-style-type: none"> 1. Reset to check if error is eliminated. 2. If error still exists, please contact the after-sales personnel.

Maintenance and care

Error code	Error type	Error information	Possible causes	Solutions
0x0104	Stop level	Probe fails to arrive at cleaning position OC.	<ol style="list-style-type: none"> 1. Probe motor OC. damaged. 2. Probe motor OC. drive chip damaged. 3. Probe motor OC. lost step. 4. The probe component is abnormally stuck during operation. 	<ol style="list-style-type: none"> 1. Reset to check if error is eliminated. 2. If error still exists, please contact the after-sales personnel.
0x0105	Stop level	Probe fails to leave from paired OC.	<ol style="list-style-type: none"> 1. Probe motor U-shaped OC. damaged. 2. Probe motor OC. drive chip damaged. 3. Probe motor OC. lost step. 4. The probe component is abnormally stuck during operation. 	<ol style="list-style-type: none"> 1. Reset to check if error is eliminated. 2. If error still exists, please contact the after-sales personnel.
0x0106	Stop level	Probe fails to arrive at paired OC.	<ol style="list-style-type: none"> 1. Probe motor U-shaped OC. damaged. 2. Probe motor OC. drive chip damaged. 3. Probe motor OC. lost step. 4. The probe component is abnormally stuck during operation. 	<ol style="list-style-type: none"> 1. Reset to check if error is eliminated. 2. If error still exists, please contact the after-sales personnel.
0x0107	Stop level	Probe fails to arrive at dropping OC.	<ol style="list-style-type: none"> 1. Probe motor OC. damaged. 2. Probe motor OC. drive chip damaged. 3. Probe motor OC. lost step. 4. The probe component is abnormally stuck during operation. 	<ol style="list-style-type: none"> 1. Reset to check if error is eliminated. 2. If error still exists, please contact the after-sales personnel.

Error code	Error type	Error information	Possible causes	Solutions
0x0108	Stop level	Probe does not reach the sample dispense position OC.	<ol style="list-style-type: none"> 1. Probe motor OC. damaged. 2. Probe motor OC. drive chip damaged. 3. Probe motor OC. lost step. 4. The probe component is abnormally stuck during operation. 	<ol style="list-style-type: none"> 1. Reset to check if error is eliminated. 2. If error still exists, please contact the after-sales personnel.
0x0109	Prompt level	Intaking air or blood and urine during the sample	<ol style="list-style-type: none"> 1. Insufficient sample. 2. Sample concentration too high. 3. Existence of air bubbles in fluid path. 	Check whether the sample size of the test tube is insufficient, or hematuria.
0x010A	Stop level	Motor above probe loses steps during vertical movement	<ol style="list-style-type: none"> 1. Probe motor OC. drive chip damaged. 2. Probe motor lost step during up and down movement. 	<ol style="list-style-type: none"> 1. Reset to check if error is eliminated. 2. If error still exists, please contact the after-sales personnel.
0x010B	Stop level	Master control abnormal power off	Abnormal power failure of the whole device	<ol style="list-style-type: none"> 1. Reset to check if error is eliminated. 2. If error still exists, please contact the after-sales personnel.
0x0201	Stop level	Abn. tube-rack-transfer-out motor	The drive chip of the rack transfer motor is damaged.	<ol style="list-style-type: none"> 1. Reset to check if error is eliminated. 2. If error still exists, please contact the after-sales personnel.
0x0204	Stop level	Abn. tube-rack-push-out motor	The drive chip of the rack transfer motor is damaged.	<ol style="list-style-type: none"> 1. Reset to check if error is eliminated. 2. If error still exists, please contact the after-sales personnel.

Maintenance and care

Error code	Error type	Error information	Possible causes	Solutions
0x0205	Stop level	Tube-rack-push-out motor fails to arrive at OC.	<ol style="list-style-type: none"> 1. Sample tray push-out drive chip damaged. 2. Sample tray push-out OC. damaged. 3. Sample tray push-out motor lost step. 	<ol style="list-style-type: none"> 1. Reset to check if error is eliminated. 2. If error still exists, please contact the after-sales personnel.
0x0206	Stop level	Tube-rack-push-out motor fails to leave from OC.	<ol style="list-style-type: none"> 1. Sample tray push-out drive chip damaged. 2. Sample tray push-out OC. damaged. 3. Sample tray push-out motor lost step. 	<ol style="list-style-type: none"> 1. Reset to check if error is eliminated. 2. If error still exists, please contact the after-sales personnel.
0x0207	Stop level	Abn. tube-rack-shift motor	Transfer-rack motor drive chip damaged.	<ol style="list-style-type: none"> 1. Reset to check if error is eliminated. 2. If error still exists, please contact the after-sales personnel.
0x0208	Stop level	Tube-rack-shift motor fails to arrive at OC.	<ol style="list-style-type: none"> 1. Sample tray transfer-rack motor drive chip damaged. 2. Sample tray transfer-rack motor OC. damaged. 3. Sample tray transfer-rack motor lost step. 	<ol style="list-style-type: none"> 1. Reset to check if error is eliminated. 2. If error still exists, please contact the after-sales personnel.
0x0209	Stop level	Tube-rack-shift motor fails to leave from OC.	<ol style="list-style-type: none"> 1. Sample tray transfer-rack motor drive chip damaged. 2. Sample tray transfer-rack motor OC. damaged. 3. Sample tray transfer-rack motor lost step. 	<ol style="list-style-type: none"> 1. Reset to check if error is eliminated. 2. If error still exists, please contact the after-sales personnel.
0x020A	Stop level	Abn. tube-rack-push-in motor	Sample tray rack-in motor drive chip damaged.	<ol style="list-style-type: none"> 1. Reset to check if error is eliminated. 2. If error still exists, please contact the after-sales personnel.

Error code	Error type	Error information	Possible causes	Solutions
0x020B	Stop level	Tube-rack-push-in motor fails to arrive at OC.	<ol style="list-style-type: none"> 1. Sample tray rack-in motor drive chip damaged. 2. Sample tray rack-in motor OC. damaged. 3. Sample tray rack-in motor lost step. 	<ol style="list-style-type: none"> 1. Reset to check if error is eliminated. 2. If error still exists, please contact the after-sales personnel.
0x020C	Stop level	Tube-rack-push-in motor fails to leave from OC.	<ol style="list-style-type: none"> 1. Sample tray rack-in motor drive chip damaged. 2. Sample tray rack-in motor OC. damaged. 3. Sample tray rack-in motor lost step. 	<ol style="list-style-type: none"> 1. Reset to check if error is eliminated. 2. If error still exists, please contact the after-sales personnel.
0x020D	Stop level	Abn. tube-rack-transfer-in motor	Sample tray transfer-in motor drive chip damaged.	<ol style="list-style-type: none"> 1. Reset to check if error is eliminated. 2. If error still exists, please contact the after-sales personnel.
0x0210	Prompt level	Recycling area full	<ol style="list-style-type: none"> 1. Recycling area OC. damaged. 2. Recycling area OC. Blocked. 3. Recycling area is full. 	<ol style="list-style-type: none"> 1. Take away the test tube rack in the retired rack area and then continue the test. 2. Reset to check if error is eliminated. 3. If error still exists, please contact the after-sales personnel.
0x0211	Stop level	Abn. encoder of tube-rack-shift motor	<ol style="list-style-type: none"> 1. Sample tray transfer-rack motor drive chip damaged. 2. Sample tray transfer-rack motor OC. damaged. 3. Sample tray transfer-rack motor lost step. 	<ol style="list-style-type: none"> 1. Reset to check if error is eliminated. 2. If error still exists, please contact the after-sales personnel.
0x0212	Stop level	Abn. signal of tube-rack in-place switch	Rack-in OC. signal damaged.	<ol style="list-style-type: none"> 1. Reset to check if error is eliminated. 2. If error still exists, please contact the after-sales personnel.

Maintenance and care

Error code	Error type	Error information	Possible causes	Solutions
0x0214	Prompt level	No sample rack to be tested	<ol style="list-style-type: none"> 1. Rack-in-position OC. signal damaged. 2. Sample test completed. 	Start the test after placing the test tube rack.
0x0215	Stop level	Loss of tube rack when combined-use	<ol style="list-style-type: none"> 1. Transport tape OC. damaged. 2. Tube rack transport tape is taken away. 	<ol style="list-style-type: none"> 1. Reset to check if error is eliminated. 2. If error still exists, please contact the after-sales personnel.
0x0216	Stop level	Transfer times out when combined-use	<ol style="list-style-type: none"> 1. Transport tape OC. damaged. 2. Tube rack transport tape is taken away. 	<ol style="list-style-type: none"> 1. Reset to check if error is eliminated. 2. If error still exists, please contact the after-sales personnel.
0x0217	Stop level	Tube rack is moved	<ol style="list-style-type: none"> 1. Tube rack is moved. 2. Sample tray transfer-rack motor abnormal. 	<ol style="list-style-type: none"> 1. Reset to check if error is eliminated. 2. If error still exists, please contact the after-sales personnel.
0x0221	Prompt level	Emergency area not ready	<ol style="list-style-type: none"> 1. Emergency judgment OC. or emergency tube in-position OC. damaged. 2. Emergency tube not effectively placed. 	<ol style="list-style-type: none"> 1. Check whether the emergency test tube is placed properly. 2. Reset to check if error is eliminated. 3. If error still exists, please contact the after-sales personnel.
0x0301	Stop level	Abn. strip-placing motor	<ol style="list-style-type: none"> 1. The drive chip of strip-release motor is damaged. 2. The detection OC. of strip-release motor is damaged. 3. Step loss during the operation of strip-release motor. 	<ol style="list-style-type: none"> 1. Reset to check if error is eliminated. 2. If error still exists, please contact the after-sales personnel.

Error code	Error type	Error information	Possible causes	Solutions
0x0302	Stop level	Strip-placing motor fails to arrive at OC.	<ol style="list-style-type: none"> 1. The drive chip of strip-release motor is damaged. 2. The detection OC. of strip-release motor is damaged. 3. Step loss during the operation of strip-release motor. 	<ol style="list-style-type: none"> 1. Reset to check if error is eliminated. 2. If error still exists, please contact the after-sales personnel.
0x0303	Stop level	Abn. strip-pick motor	<ol style="list-style-type: none"> 1. The drive chip of strip-pick motor is damaged. 2. The detection OC. of strip-pick motor is damaged. 3. Step loss during the operation of strip-pick motor. 	<ol style="list-style-type: none"> 1. Reset to check if error is eliminated. 2. If error still exists, please contact the after-sales personnel.
0x0304	Stop level	Strip-pick motor fails to arrive at OC.	<ol style="list-style-type: none"> 1. The drive chip of strip-pick motor is damaged. 2. The detection OC. of strip-pick motor is damaged. 3. Step loss during the operation of strip-pick motor. 	<ol style="list-style-type: none"> 1. Reset to check if error is eliminated. 2. If error still exists, please contact the after-sales personnel.
0x0305	Stop level	Strip jamming in picker	Test strip stuck in strip picker	<ol style="list-style-type: none"> 1. Check whether there are any test strips with changed shapes in the strip picker, and if so, remove the jammed test strips. 2. Clean the strip picker with a brush. 3. Purge the debris in the strip picker with the rubber suction ball. 4. Reset to check whether error is cleared. 5. If error still exists, please contact the after-sales personnel.

Maintenance and care

Error code	Error type	Error information	Possible causes	Solutions
0x0306	Stop level	No strip in strip picker	The strips have used up	Replenish the strip and continue to test
0x0307	Stop level	Strip-pick light tracing failed	Parameter error	Start light tracing again
0x0308	Stop level	Strip-pick motor fails to leave from OC.	<ol style="list-style-type: none"> 1. The drive chip of strip-pick motor is damaged. 2. The detection OC. of strip-pick motor is damaged. 3. Step loss during the operation of strip-pick motor. 	<ol style="list-style-type: none"> 1. Reset to check whether error is cleared. 2. If error still exists, please contact the after-sales personnel.
0x0309	Prompt level	Standard strip picking failed	The standard strip has not picked correctly	Place the standard strip again and continue to test
0x0401	Stop level	Strip-push motor abnormality	The drive chip of strip-push motor is damaged	<ol style="list-style-type: none"> 1. Reset to check whether error is cleared. 2. If error still exists, please contact the after-sales personnel.
0x0402	Stop level	Strip-push motor fails to arrive at OC.	<ol style="list-style-type: none"> 1. The drive chip of strip-push motor is damaged. 2. The detection OC. of strip-push motor is damaged. 3. Step loss during the operation of strip-push motor. 	<ol style="list-style-type: none"> 1. Reset to check whether error is cleared. 2. If error still exists, please contact the after-sales personnel.
0x0403	Stop level	Strip-push motor fails to leave from OC.	<ol style="list-style-type: none"> 1. The drive chip of strip-push motor is damaged. 2. The detection OC. of strip-push motor is damaged. 3. Step loss during the operation of strip-push motor. 	<ol style="list-style-type: none"> 1. Reset to check whether error is cleared. 2. If error still exists, please contact the after-sales personnel.

Error code	Error type	Error information	Possible causes	Solutions
0x0404	Stop level	Abn. strip-transport motor	The drive chip of strip-transport motor is damaged	<ol style="list-style-type: none"> 1. Reset to check whether error is cleared. 2. If error still exists, please contact the after-sales personnel.
0x0405	Stop level	Strip-transport motor does not reach the OC.	<ol style="list-style-type: none"> 1. The drive chip of strip-transport motor is damaged. 2. The detection OC. of strip-transport motor is damaged. 3. Step loss during the operation of strip-transport motor. 	<ol style="list-style-type: none"> 1. Reset to check whether error is cleared. 2. If error still exists, please contact the after-sales personnel.
0x0406	Stop level	Strip-transport motor fails to leave from OC.	<ol style="list-style-type: none"> 1. The drive chip of strip-transport motor is damaged. 2. The detection OC. of strip-transport motor is damaged. 3. Step loss during the operation of strip-transport motor. 	<ol style="list-style-type: none"> 1. Reset to check whether error is cleared. 2. If error still exists, please contact the after-sales personnel.
0x0407	Stop level	Abn. test motor	The drive chip of the test motor is damaged	<ol style="list-style-type: none"> 1. Reset to check whether error is cleared. 2. If error still exists, please contact the after-sales personnel.
0x0408	Stop level	Test motor fails to arrive at OC.	<ol style="list-style-type: none"> 1. The drive chip of test motor is damaged. 2. The detection OC. of test motor is damaged; 3. Step loss during the operation of test motor. 	<ol style="list-style-type: none"> 1. Reset to check whether error is cleared. 2. If error still exists, please contact the after-sales personnel.

Maintenance and care

Error code	Error type	Error information	Possible causes	Solutions
0x0409	Stop level	Test motor fails to leave from OC.	<ol style="list-style-type: none"> 1. The drive chip of test motor is damaged. 2. The detection OC. of test motor is damaged. 3. Step loss during the operation of test motor. 	<ol style="list-style-type: none"> 1. Reset to check whether error is cleared. 2. If error still exists, please contact the after-sales personnel.
0x040A	Stop level	Abn. signal of rejudge OC.	The rejudge OC. of strip-transport module is damaged or abnormally blocked	<ol style="list-style-type: none"> 1. Reset to check whether error is cleared. 2. If error still exists, please contact the after-sales personnel.
0x040B	Stop level	Loss or turnover of strip when rejudge	The test strip is turned over or lost during transporting	<ol style="list-style-type: none"> 1. Clean the bedplate. 2. Reset to check whether error is cleared. 3. If error still exists, please contact the after-sales personnel.
0x040C	Stop level	Strip-transport board fails to be in position	<ol style="list-style-type: none"> 1. The bedplate is not installed in place. 2. The switch indicating bedplate in-place installation is damaged. 	<ol style="list-style-type: none"> 1. Re-plug the bedplate. 2. Reset to check whether error is cleared. 3. If error still exists, please contact the after-sales personnel.
0x040E	Prompt level	Waste strip container full	<ol style="list-style-type: none"> 1. The OC. determining full waste strip box is damaged. 2. The waste strip box is full. 	Empty the waste box and continue the test.
0x0601	Stop level	Abn. light source of acquisition board	The light source of acquisition plate is abnormal	<ol style="list-style-type: none"> 1. Check whether the white reference is clean. 2. Reset to check whether error is cleared. 3. If error still exists, please contact the after-sales personnel.

Error code	Error type	Error information	Possible causes	Solutions
0x0602	Prompt level	Abn. white benchmark in testing	White benchmark abnormal during testing	Check whether the benchmark is cleaned in standby state.
0x0604	Prompt level	No strip detected in test area	The test strip is slanted or no test strip is detected in the test position.	Clean the bedplate of the strip-transport unit in standby state.
0x0605	Prompt level	Insufficient drops on strips	Insufficient drops on strips	In standby state, check whether the test tube has insufficient sample volume.
0x0606	Prompt level	Abn. strip	Abnormal strip	Check whether it is the strip supplied by Zybio.
0x0501	Stop level	SV1 valve abnormal	<ol style="list-style-type: none"> SV1 solenoid valve abnormal. Solenoid valve not connected or the cable disconnected. 	<ol style="list-style-type: none"> Reset to check whether error is cleared. If error still exists, please contact the after-sales personnel.
0x0502	Stop level	SV2 valve abnormal	<ol style="list-style-type: none"> SV2 solenoid valve abnormal. Solenoid valve not connected or the cable disconnected. 	<ol style="list-style-type: none"> Reset to check whether error is cleared. If error still exists, please contact the after-sales personnel.
0x0503	Stop level	SV3 valve abnormal	<ol style="list-style-type: none"> SV3 solenoid valve abnormal. Solenoid valve not connected or the cable disconnected. 	<ol style="list-style-type: none"> Reset to check whether error is cleared. If error still exists, please contact the after-sales personnel.
0x0504	Stop level	SV4 valve abnormal	<ol style="list-style-type: none"> SV4 solenoid valve abnormal. Solenoid valve not connected or the cable disconnected. 	<ol style="list-style-type: none"> Reset to check whether error is cleared. If error still exists, please contact the after-sales personnel.

Maintenance and care

Error code	Error type	Error information	Possible causes	Solutions
0x0505	Stop level	SV5 valve abnormal	<ol style="list-style-type: none"> SV5 solenoid valve abnormal. Solenoid valve not connected or the cable disconnected. 	<ol style="list-style-type: none"> Reset to check whether error is cleared. If error still exists, please contact the after-sales personnel.
0x0506	Stop level	SV6 valve abnormal	<ol style="list-style-type: none"> SV6 solenoid valve abnormal. Solenoid valve not connected or the cable disconnected. 	<ol style="list-style-type: none"> Reset to check whether error is cleared. If error still exists, please contact the after-sales personnel.
0x0507	Stop level	SV7 valve abnormal	<ol style="list-style-type: none"> SV7 solenoid valve abnormal. Solenoid valve not connected or the cable disconnected. 	<ol style="list-style-type: none"> Reset to check whether error is cleared. If error still exists, please contact the after-sales personnel.
0x0508	Stop level	SV8 valve abnormal	<ol style="list-style-type: none"> SV8 solenoid valve abnormal. Solenoid valve not connected or the cable disconnected. 	<ol style="list-style-type: none"> Reset to check whether error is cleared. If error still exists, please contact the after-sales personnel.
0x0509	Stop level	SV9 valve abnormal	<ol style="list-style-type: none"> SV9 solenoid valve abnormal. Solenoid valve not connected or the cable disconnected. 	<ol style="list-style-type: none"> Reset to check whether error is cleared. If error still exists, please contact the after-sales personnel.
0x050A	Stop level	SV10 valve abnormal	<ol style="list-style-type: none"> SV10 solenoid valve abnormal. Solenoid valve not connected or the cable disconnected. 	<ol style="list-style-type: none"> Reset to check whether error is cleared. If error still exists, please contact the after-sales personnel.

Error code	Error type	Error information	Possible causes	Solutions
0x050B	Stop level	SV11 valve abnormal	<ol style="list-style-type: none"> SV11 solenoid valve abnormal. Solenoid valve not connected or the cable disconnected. 	<ol style="list-style-type: none"> Reset to check whether error is cleared. If error still exists, please contact the after-sales personnel.
0x050C	Stop level	SV12 valve abnormal	<ol style="list-style-type: none"> SV12 solenoid valve abnormal. Solenoid valve not connected or the cable disconnected. 	<ol style="list-style-type: none"> Reset to check whether error is cleared. If error still exists, please contact the after-sales personnel.
0x0510	Stop level	Sample-aspiration motor fails to arrive at OC.	<ol style="list-style-type: none"> Aspirate motor drive chip damaged. Aspirate motor OC. damaged. Aspirate motor lost step. 	<ol style="list-style-type: none"> Reset to check whether error is cleared. If error still exists, please contact the after-sales personnel.
0x0511	Stop level	Sample-aspiration motor fails to leave from OC.	<ol style="list-style-type: none"> Aspirate motor drive chip damaged. Aspirate motor OC. damaged. Aspirate motor lost step. 	<ol style="list-style-type: none"> Reset to check whether error is cleared. If error still exists, please contact the after-sales personnel.
0x0512	Stop level	Sample-push motor fails to arrive at OC.	<ol style="list-style-type: none"> Sample push motor drive chip damaged. Sample push motor OC. damaged. Sample push motor lost step. 	<ol style="list-style-type: none"> Reset to check whether error is cleared. If error still exists, please contact the after-sales personnel.
0x0513	Stop level	Sample-push motor fails to leave from OC.	<ol style="list-style-type: none"> Sample push motor drive chip damaged. Sample push motor OC. damaged. Sample push motor lost step. 	<ol style="list-style-type: none"> Reset to check whether error is cleared. If error still exists, please contact the after-sales personnel.

Maintenance and care

Error code	Error type	Error information	Possible causes	Solutions
0x0514	Stop level	Sheath fluid motor fails to arrive at OC.	<ol style="list-style-type: none"> 1. Sheath fluid motor drive chip damaged. 2. Sheath fluid motor OC. damaged. 3. Sheath fluid motor lost step. 	<ol style="list-style-type: none"> 1. Reset to check whether error is cleared. 2. If error still exists, please contact the after-sales personnel.
0x0515	Stop level	Sheath fluid motor fails to leave from OC.	<ol style="list-style-type: none"> 1. Sheath fluid motor drive chip damaged. 2. Sheath fluid motor OC. damaged. 3. Sheath fluid motor lost step. 	<ol style="list-style-type: none"> 1. Reset to check whether error is cleared. 2. If error still exists, please contact the after-sales personnel.
0x0516	Stop level	Built-in waste liquid pool full	<ol style="list-style-type: none"> 1. Internal waste pool OC. damaged. 2. Internal waste pool full. 	<ol style="list-style-type: none"> 1. Reset to check whether error is cleared. 2. If error still exists, please contact the after-sales personnel.
0x0517	Prompt level	Empty sheath fluid buffer bottle	<ol style="list-style-type: none"> 1. Sheath fluid buffer bottle sensor damaged. 2. Sheath fluid buffer bottle empty. 	<ol style="list-style-type: none"> 1. Check the residual of reagent in the external buffer bottle. 2. Reset to check whether error is cleared. 3. If error still exists, please contact the after-sales personnel.
0x0518	Prompt level	Waste liquid container full	<ol style="list-style-type: none"> 1. The float of waste liquid container is damaged. 2. The waste liquid container is full. 	<ol style="list-style-type: none"> 1. Pour off the waste liquid. 2. Check whether the float switch of waste liquid container is abnormal.
0x0519	Prompt level	Sheath fluid bucket empty	<ol style="list-style-type: none"> 1. The float of container is damaged. 2. The sheath fluid has been used up. 	<ol style="list-style-type: none"> 1. Replace sheath fluid. 2. Check whether the float switch of the sheath fluid container is abnormal.

Error code	Error type	Error information	Possible causes	Solutions
0x051C	Stop level	Abnormal fluidics pressure	The hydraulic sensor is damaged	<ol style="list-style-type: none"> 1. Reset to check whether error is cleared. 2. If error still exists, please contact the after-sales personnel.
0x0702	Stop level	Rack-in module command times out	<ol style="list-style-type: none"> 1. The sample tray module is not connected. 2. The communication line of the sample tray module is disconnected. 	<ol style="list-style-type: none"> 1. Shut down, restart, reset and check whether error is cleared. 2. If error still exists, please contact the after-sales personnel.
0x0703	Stop level	Strip-pick module command times out	<ol style="list-style-type: none"> 1. The strip-pick module is not connected. 2. The communication line of the strip-pick module is disconnected. 	<ol style="list-style-type: none"> 1. Shut down, restart, reset and check whether error is cleared. 2. If error still exists, please contact the after-sales personnel.
0x0704	Stop level	Strip-transfer module command times out	<ol style="list-style-type: none"> 1. The strip-pick module is not connected. 2. The communication line of the strip-transport module is disconnected. 	<ol style="list-style-type: none"> 1. Shut down, restart, reset and check whether error is cleared. 2. If error still exists, please contact the after-sales personnel.
0x0705	Stop level	Test board command times out	<ol style="list-style-type: none"> 1. The test plate module is not connected. 2. The communication line of the test plate module is disconnected. 	<ol style="list-style-type: none"> 1. Shut down, restart, reset and check whether error is cleared. 2. If error still exists, please contact the after-sales personnel.
0x0707	Stop level	PHYC module command times out	<ol style="list-style-type: none"> 1. The physicochemical module is not connected. 2. The communication line of the physicochemical module is disconnected. 	<ol style="list-style-type: none"> 1. Shut down, restart, reset and check whether error is cleared. 2. If error still exists, please contact the after-sales personnel.

Maintenance and care

Error code	Error type	Error information	Possible causes	Solutions
0x0708	Stop level	Conductivity plate command times out	<ol style="list-style-type: none"> 1. Conductivity module not connected. 2. Communication circuit of conductivity module disconnected. 	<ol style="list-style-type: none"> 1. Shut down, restart, reset and check whether error is cleared. 2. If error still exists, please contact the after-sales personnel.
0x0802	Stop level	Focus motor does not leave from the zero position OC.	<ol style="list-style-type: none"> 1. Focus motor drive chip damaged. 2. Focus motor OC. damaged. 3. Focus motor lost step. 	<ol style="list-style-type: none"> 1. Reset to check whether error is cleared. 2. If error still exists, please contact the after-sales personnel.
0x0803	Stop level	Focus motor does not reach zero position OC.	<ol style="list-style-type: none"> 1. Focus motor drive chip damaged. 2. Focus motor OC. damaged. 3. Focus motor lost step. 	<ol style="list-style-type: none"> 1. Reset to check whether error is cleared. 2. If error still exists, please contact the after-sales personnel.
0x0A01	Stop level	Abnormal color light source	The color acquisition parameter is abnormal	<ol style="list-style-type: none"> 1. Reset to check whether error is cleared. 2. Re-prime the fluidics, reset and check whether error is cleared. 3. If error still exists, please contact the after-sales personnel.
0x0A02	Stop level	Specific gravity light source abnormal	The specific gravity acquisition parameter is abnormal	<ol style="list-style-type: none"> 1. Reset to check whether error is cleared. 2. Re-prime the fluidics, reset and check whether error is cleared. 3. If error still exists, please contact the after-sales personnel.

Error code	Error type	Error information	Possible causes	Solutions
0x0A03	Stop level	Turbidity light source abnormal	The turbidity acquisition parameter is abnormal	<ol style="list-style-type: none"> 1. Reset to check whether error is cleared. 2. Re-prime the fluidics, reset and check whether error is cleared. 3. If error still exists, please contact the after-sales personnel.
0x0B01	Stop level	Conductivity self-check failed	The acquisition parameter of conductivity is abnormal	<ol style="list-style-type: none"> 1. Reset to check whether error is cleared. 2. Re-prime the fluidics, reset and check whether error is cleared. 3. If error still exists, please contact the after-sales personnel.
0xF001	Stop level	Grayscale adjustment failed	<ol style="list-style-type: none"> 1. Camera failure. 2. Camera not triggered. 3. Camera network cable failure 	<ol style="list-style-type: none"> 1. Reset to check whether error is cleared. 2. If error still exists, please contact the after-sales personnel.
0xF002	Stop level	Waiting for image times out prevents analysis of the current sample	<ol style="list-style-type: none"> 1. Camera failure. 2. Camera not triggered. 3. Camera network cable failure. 	<ol style="list-style-type: none"> 1. Check whether the network connection cable connecting the instrument to the computer is normal. 2. Check the computer system is infected with viruses and remove them. 3. Restart the computer and the instrument, if error still exists, please contact the after-sales personnel.

Maintenance and care

Error code	Error type	Error information	Possible causes	Solutions
0xF003	Stop level	Sample rack push times out	<ol style="list-style-type: none"> 1. Abnormal disconnection of serial port. 2. The instrument does not respond to the command. 3. Sample tray failure 	<ol style="list-style-type: none"> 1. Reset to check whether error is cleared. 2. If error still exists, please contact the after-sales personnel.
0xF004	Stop level	Reset instrument times out	<ol style="list-style-type: none"> 1. Abnormal disconnection of serial port 2. The instrument sample tray and other units are not connected normally 	<ol style="list-style-type: none"> 1. Reset to check whether error is cleared. 2. If error still exists, please contact the after-sales personnel.
0xF005	Stop level	Mismatch between the tube rack No. of Dry CHM. end and morphological end of the sample	<ol style="list-style-type: none"> 1. Dry chemistry test device or morphology test device didn't recognize the tube number and rack number correctly. 2. After scanning of tube number and rack number by the dry chemistry device, the tube or rack positions are changed. 	<ol style="list-style-type: none"> 1. Reset to check whether error is cleared. 2. If error still exists, please contact the after-sales personnel.
0xF006	Stop level	Sample rack push times out	<ol style="list-style-type: none"> 1. Abnormal disconnection of serial port 2. Accidental disconnection of sample tray 	<ol style="list-style-type: none"> 1. Reset to check whether error is cleared. 2. If error still exists, please contact the after-sales personnel.
0xF007	Stop level	Failed to read or set slave computer parameters	<ol style="list-style-type: none"> 1. Abnormal disconnection of serial port 2. Device didn't respond to the command. 	<ol style="list-style-type: none"> 1. Reset to check whether error is cleared. 2. If error still exists, please contact the after-sales personnel.

Error code	Error type	Error information	Possible causes	Solutions
0xF008	Stop level	Sample tray reset times out	<ol style="list-style-type: none"> 1. Abnormal disconnection of serial port. 2. Device didn't respond to the command. 	<ol style="list-style-type: none"> 1. Reset to check whether error is cleared. 2. If error still exists, please contact the after-sales personnel.
0xF009	Prompt level	Instrument temperature too low	<ol style="list-style-type: none"> 1. Device temperature too low. 2. Temperature sensor failure 	<ol style="list-style-type: none"> 1. Check whether the ambient temperature is in the working range. 2. Check whether the temperature displayed by the instrument matches with the ambient temperature. 3. Reset, if error still exists, please contact the after-sales personnel.
0xF010	Prompt level	Over-temperature of instrument	<ol style="list-style-type: none"> 1. Device temperature too high. 2. Temperature sensor failure 	<ol style="list-style-type: none"> 1. Check whether the ambient temperature is in the working range. 2. Check whether the temperature displayed by the instrument matches with the ambient temperature. 3. Reset, if error still exists, please contact the after-sales personnel.
0xF011	Prompt level	Mismatch between tube No. and rack No.	<ol style="list-style-type: none"> 1. Dry chemistry test device or morphology test device didn't recognize the tube number and rack number correctly. 2. After scanning of tube number and rack number by the dry chemistry device, the tube or rack positions are changed. 	<ol style="list-style-type: none"> 1. Reset to check whether error is cleared. 2. If error still exists, please contact the after-sales personnel.

Maintenance and care

Error code	Error type	Error information	Possible causes	Solutions
0xF012	Stop level	No physicochemical unit detected	<ol style="list-style-type: none"> 1. Abnormal disconnection of serial port. 2. The instrument does not respond to the command. 3. Whether there is any setup error in the corresponding unit of the software 	<ol style="list-style-type: none"> 1. Reset to check whether error is cleared. 2. If error still exists, please contact the after-sales personnel.
0xF013	Stop level	No conductivity unit detected	<ol style="list-style-type: none"> 1. Abnormal disconnection of serial port. 2. The instrument does not respond to the command. 3. Whether there is any setup error in the corresponding unit of the software. 	<ol style="list-style-type: none"> 1. Reset to check whether error is cleared. 2. If error still exists, please contact the after-sales personnel.
0xF014	Stop level	Sheath fluid replenish is exhausted, please replenish	Sheath times have been used up	Replenish sheath fluid
0xF015	Stop level	PHYC light tracing failed	<ol style="list-style-type: none"> 1. Abnormal light tracing parameter. 2. Physicochemical unit module failure. 	<ol style="list-style-type: none"> 1. Reset to check whether error is cleared. 2. If error still exists, please contact the after-sales personnel.
0xF016	Stop level	Dry CHM. light tracing failed	<ol style="list-style-type: none"> 1. Abnormal light tracing parameter. 2. Physicochemical unit module failure 	<ol style="list-style-type: none"> 1. Reset to check whether error is cleared. 2. If error still exists, please contact the after-sales personnel.
0xF017	Prompt level	Zero image received	<ol style="list-style-type: none"> 1. Camera failure or camera power failure. 2. The camera is not triggered to take pictures. 3. Camera network cable failure. 4. Accidental damage of camera driver. 	<ol style="list-style-type: none"> 1. Reset to check whether error is cleared. 2. If error still exists, please contact the after-sales personnel.

Error code	Error type	Error information	Possible causes	Solutions
0xF018	Stop level	Morphology calibration failed	<ol style="list-style-type: none"> 1. The network cable connecting the instrument and the computer is loosened or disconnected. 2. The calibrator is not shaken for mixing before calibration. 3. Calibrator expired. 4. No focusing performed before calibration. 	<ol style="list-style-type: none"> 1. Check if the network cable connection is reliable. 2. Check if the calibrator is well mixed or expired. 3. Calibrate again after reset, if error still exists, please contact the after-sales personnel.
0xF019	Stop level	Focusing failed	<ol style="list-style-type: none"> 1. The network cable connecting the instrument and the computer is loosened or disconnected. 2. The focusing fluid is not shaken for mixing before focusing. 3. Focusing fluid expired. 	<ol style="list-style-type: none"> 1. Check if the network cable connection is reliable. 2. Check if the focusing fluid is well mixed or expired. 3. Focus again after reset, if error still exists, please contact the after-sales personnel.
0xF020	Stop level	Morphology QC failed	<ol style="list-style-type: none"> 1. The network cable connecting the instrument and the computer is loosened or disconnected. 2. The control is not shaken for mixing before QC. 3. Control expired. 	<ol style="list-style-type: none"> 1. Check if the network cable connection is reliable. 2. Check if the control is well mixed or expired. 3. Perform QC again after reset, if error still exists, please contact the after-sales personnel.
0xF021	Stop level	Conductivity calibration failed	<ol style="list-style-type: none"> 1. Calibrators are placed in wrong order. 2. The calibrator is not shaken for mixing before calibration. 3. Calibrator expired. 	<ol style="list-style-type: none"> 1. Check if the calibrators are placed in wrong order. 2. Check if the calibrator is well mixed or expired. 3. Calibrate again after reset, if error still exists, please contact the after-sales personnel.

Maintenance and care

Error code	Error type	Error information	Possible causes	Solutions
0xF022	Stop level	Conductivity QC failed	<ol style="list-style-type: none"> 1. Controls are placed in wrong order. 2. The control is not shaken for mixing before calibration. 3. Control expired. 	<ol style="list-style-type: none"> 1. Check if the controls are placed in wrong order. 2. Check if the control is well mixed or expired. 3. Perform QC again after reset, if error still exists, please contact the after-sales personnel.
0xF023	Stop level	Dry CHM. QC failed	<ol style="list-style-type: none"> 1. Controls are placed in wrong order. 2. The control is not shaken for mixing before calibration. 3. Control expired. 	<ol style="list-style-type: none"> 1. Check if the controls are placed in wrong order. 2. Check if the control is well mixed or expired. 3. Perform QC again after reset, if error still exists, please contact the after-sales personnel.
0xF024	Stop level	Standard strip test failed	<ol style="list-style-type: none"> 1. The standard strip is stained or damaged. 2. The specified standard strip is not used 	<ol style="list-style-type: none"> 1. Check if standard strip is stained or damaged. 2. Check if specified standard strip is used. 3. Perform standard strip test again after reset, if error still exists, please contact the after-sales personnel.

Appendix A Related information

The appendix mainly introduces the information related to the instrument, covering explanation of terms, parts list, information of supporting cables, etc.

A.1 Terms

Focusing: the process of making the captured scene clearly imaged on the sensor. It is also called focusing and imaging.

A.2 Accessory and reagent list

The accessories and the reagent used of the instrument are as follows:

Table A-1 Accessory list

No.	Accessory name
1	Computer
2	Handheld barcode scanner
3	Tube rack component
4	Standard strip component with assigned value
5	Plastic waste strip box
6	Power cord
7	Serial cable
8	Network cable
9	Door key
10	Printer (prepared by users)

Table A-2 List of miscellaneous materials

No.	Name
1	Protective suit
2	Surgical mask
3	Disposable latex gloves
4	Protective glass
5	75% ethanol
6	Cotton swab
7	Medical gauze
Note: users shall prepare the materials above and the list may not be exhaustive.	

Table A-3 Reagent list

No.	Reagent name
1	Urinalysis Strip (Dry Chemistry Method)
2	Focusing Fluid
3	Color Control
4	US-Calibrator
5	Sediment Control
6	Conductivity Control
7	Turbidity Control
8	SG Control
9	Turbidity Calibrator
10	Conductivity Calibrator
11	SG Calibrator
12	UDC-Control
13	Sheath Fluid
14	Wash solution
15	Urinalysis Diluent

Note: for ordering of reagents, please contact Zybio or its local distributor.

A.3 Cable information

The cable information of the instrument is as follows:

Table A-4 Cable information

Name	Cable length	Shielded or not
Power cord (AC 250V 10A)	1.5m	No
Liquid waste sensor connecting cable	2.0m	Yes
Sheath fluid sensor connecting cable	1.5m	Yes
Serial port cable	1.5m	Yes
Network cable	1.5m	Yes

Note: before using the unspecified accessories or cables, consult Zybio or its local distributor first. External items connected to the instrument shall not reduce the safety and performance of the instrument.

A.4 Training

Zybio will send its designated after-sales service personnel or its local distributor to provide field training for users to ensure correct use and performance of the instrument. For customer training, please contact the local distributor of Zybio.

Appendix B Literature

1. ISO 20916:2019 In vitro diagnostic medical devices - Clinical performance studies using specimens from human subjects - Good study practice.
2. EN ISO 18113-1:2011, In vitro diagnostic medical devices-Information supplied by the manufacturer(labelling)-Part 1: Terms, definitions and general requirements.
3. EN ISO 18113-3:2011, In vitro diagnostic medical devices-Information supplied by the manufacturer(labelling)-Part 3: In vitro diagnostic instruments for professional use.

Urinalysis Strip (Dry Chemistry Method)

Specifications

Model	Test item	REF	Spec.
11FU	Urobilinogen, Bilirubin, Ketone, Leukocyte, Nitrite, Protein, Blood, Glucose, Specific gravity, pH, Vitamin C	01.09.1F.01.01.04	100 Tests
12FU	Urobilinogen, Bilirubin, Ketone, Leukocyte, Nitrite, Protein, Blood, Microalbumin, Glucose, Specific gravity, pH, Vitamin C	01.09.1F.01.01.05	100 Tests
14FU	Urobilinogen, Bilirubin, Ketone, Leukocyte, Nitrite, Protein, Blood, Microalbumin, Creatinine, Glucose, Specific gravity, pH, Vitamin C, Calcium	01.09.1F.01.01.06	100 Tests

Intended purpose

The urinalysis strips are used for in vitro qualitative and semi-quantitative detection of urobilinogen (URO), bilirubin(BL), ketone (KET), leukocyte (LEU), nitrite(NIT), protein(PRO), blood (BLD), microalbumin (mALB), creatinine(CRE), glucose (GLU), specific gravity (SG), pH, Vitamin C(Vc) and calcium (Ca) in human urine.

Summary and explanation

It is mainly used for the auxiliary diagnosis of glucose, renal, liver, acid-base balance, and urinary tract infections. The strips are only used for clinical examination screening tests in hospitals.

Test principle

- 1.Urobilinogen(URO):the urobilinogen couples with diazonium salt under strongly acidic condition to produce fuchsia dye.
- 2.Bilirubin(BL):the direct bilirubin couples with dichloroaniline diazonium salt under acidic condition to produce an azo dye.
- 3.Ketone (KET): the acetoacetic acid reacts with sodium nitroferricyanide under alkaline condition to form fuchsia compound.
4. Leukocyte (LEU): the phenolic ester is hydrolyzed by esterase in neutrophil to form free phenol, which couples with diazonium salt to produce purple azo dye.
- 5.Nitrite (NIT): the diazotization reaction of nitrite and sulfonamide produces diazo compound, and the diazo compound couples with tetrahydrobenzoquinolin-3-ol to produce red azo dye.
- 6.Protein (PRO): the anion produced by pH indicator combines with the protein with cation to produce compound, which promotes the further ionization of the pH indicator and makes its color change. This phenomenon is called the error

method of indicator protein.

7.Blood (BLD): the hemoglobin has peroxidase-like activity, with which peroxide can be decomposed to release nascent oxygen (O), and the nascent oxygen (O) oxidizes the indicator and makes its color change.

8.Microalbumin (mALB): it is tested by sulfophthalein dye with high sensitivity to albumin according to the principle of protein error.

9.Creatinine (CRE): the creatinine reacts with the 3,5-dinitrobenzoic acid to produce colored compound under strongly alkaline condition.

10.Glucose (GLU): the glucose monohydrate produces gluconic acid and hydrogen peroxide under the action of glucose oxidase. Under the action of peroxidase, the hydrogen peroxide releases nascent oxygen (O); the nascent oxygen (O) oxidizes potassium iodide, and the color changes.

11.Specific gravity (SG): the methyl vinyl ether-maleic acid copolymer is a weakly acidic (-COOH group) ion exchanger. The M+ cation (mainly Na+) in the electrolyte (M+X-) that exists in the form of salt in urine reacts with the ion exchanger to replace the hydrogen ion. The hydrogen ion reacts with the acid-base indicator to change its color.

12.pH: the acid-base indicator method is used.

13.Vitamin C (Vc):The ascorbic acid has a reducing group of 1,2-enediol, which, in alkaline condition, reduces the oxidized blue 2,6-dichlorophenol indophenol dye to colorless 2,6-dichlorobis-p-phenolamine.

14.Calcium (Ca): the calcium ion reacts with o-cresolphthalein complexone to produce fuchsia color, and the color depth is proportional to the concentration of the calcium ion.

Materials provided

Common component	Quantity
Urinalysis strip (Including: PET substrate, test paper, double-sided tape, blank block)	100 strips
Instructions for use	1 pc
Strip bottle	1 bottle

Materials required (but not provided)

Detection instrument, quality controls, general laboratory equipment.

Precautions

- 1.This reagent is for in vitro diagnostic use only.
2. It is for professional use only.
- 3.The strip must be stored in the original container; unless it is to be used immediately, the strip must not be taken out of the vial; re-cap immediately after removing the strip. Do not remove the desiccant.
- 4.Do not use expired products. The deterioration of the strip will make the color of the reaction zone lighter or darker. If the test result is inconsistent with the expected result, please check the strip for whether it is still valid and use the control for the test.
- 5.Water cannot be used as a negative control.
- 6.If the strip is not completely immersed in urine, uneven coloring may be caused and judgment may be affected.
- 7.When the strip is taken out of the urine, immediately remove the excess urine so as not to affect the result.
- 8.This product is for single use only. Please read the operation manual carefully before use, and operate in strict accordance with the requirements of the manual. Any operation or sample type that is not according to the requirements of the manual may cause an erroneous result. If the test result is abnormal or

Urinalysis Strip (Dry Chemistry Method)

there is any doubt about the test result, the test shall be conducted again, and further verification shall be done in combination with other clinical results.

9.Do not store this product in the refrigerator. Do not touch the test areas on the strip.

10.This product does not contain human-derived components, but contains chemical components, even some hazardous chemicals with potential risks. All samples and reaction wastes shall be treated as potential sources of infection. Appropriate protective measures shall be taken during sample collection, handling, storage, and the entire testing process. After being used, the product shall be treated as a biological pollutant and disposed in accordance with local regulations

Storage and stability

1.Unopened: the validity period is 12 months when stored under 4–30°C and kept away from sunlight.

2.Opened: the validity period is 3 months when stored at a cool and dry place under 4–30°C. Keep bottles tightly closed when not in use.

3.See packaging label for date of manufacture and expiry date.

Sample requirements

1.Collect fresh urine in a clean, dry container, and conduct the test as soon as possible.

2.The storage time of the urine sample at ambient temperature shall not exceed 1 hour. Otherwise, the urine sample shall be stored in a refrigerator of 2–8°C, and the measurement shall be done within 2 hours. When taken out, the refrigerated urine sample shall be restored to the ambient temperature, and stirred and shaken for homogenization before the test.

3.Do not add preservatives to the urine sample.

4.The urine sample shall not be centrifuged. Thoroughly mix the urine sample before the test.

Applicable instruments

Zybio Urine chemistry analyzer (model: U1600, U1601, U1602), and Urinalysis hybrid system (model: U3600, U3601, U3602).

Assay procedure

This product can be used for both instruments and visual reading. To make test result more reliable, please read the operation manual carefully before the test.

Working temperature: 10–30°C, humidity: ≤80%.

1. Visual reading:

- ① Immerse all of the test areas on the strip into the sample and take it out immediately;
- ② Remove the excess urine;
- ③ Compare the test area on the strip with the color scale, and the result shall be read and recorded within 1–2 minutes. A result read after 2 minutes is invalid.

2. Instrument measurement:

Please follow operation instructions on testing of the selected instrument.

Reference interval

Reference value of normal human urine for urinalysis strip:

Item	Reference	Item	Reference
URO	3.4–17 μmol/L	mALB	<30mg/L
BIL	0 μmol/L	CRE	4.4–17.7mmol/L
KET	0mmol/L	GLU	<2.8mmol/L
LEU	0 Leu/μL	SG	1.010-1.025

NIT	0mg/dL	pH	5.5-7.0
PRO	<15mg/dL	Vc	0mmol/L
BLD	<10 Ery/μL	Ca	2.5-7.5mmol/L

Reference value is determined based on the clinical urine test results of 200 healthy people. It is recommended that each laboratory establish its own reference range.

Interpretation of test result

1.Magnitude setting of test result

Strip zone	Magnitude setting						
URO	μmol/L	3.4	17	34	68	135	/
	Semi-quantitative symbol	Norm	Norm	1+	2+	3+	/
BIL	μmol/L	0	17	51	103	/	/
	Semi-quantitative symbol	-	1+	2+	3+	/	/
KET	mmol/L	0	0.5	1.5	3.9	7.8	16
	Semi-quantitative symbol	-	±	1+	2+	3+	4+
LEU	Leu/μL	0	15	70	125	500	/
	Semi-quantitative symbol	-	±	1+	2+	3+	/
NIT	mg/dL	0	0.125	0.25	/	/	/
	Semi-quantitative symbol	-	1+	2+	/	/	/
PRO	g/L	0	0.15	0.3	1	3	≥20
	Semi-quantitative symbol	-	±	1+	2+	3+	4+
BLD	Ery/μL	0	10	25	80	200	/
	Semi-quantitative symbol	-	±	1+	2+	3+	/
mALB	mg/L	10	30	80	150	/	/
CRE	mmol/L	0.9	4.4	8.8	17.7	26.5	/
	mmol/L	0	2.8	5.6	14	28	56
GLU	Semi-quantitative symbol	-	±	1+	2+	3+	4+
	value	1,000, 1,005, 1,010, 1,015, 1,020, 1,025, 1,030					
pH	value	5.0, 5.5, 6.0, 6.5, 7.0, 7.5, 8.0, 8.5, 9.0					
Vc	mmol/L	0	0.6	1.4	2.8	5.7	/
Ca	mmol/L	1	2.5	5	7.5	≥10	/

1.URO: in this test area, urobilinogen with a concentration as low as 3 μmol/L (about 0.2 Ehrlich) in urine can be detected. The normal content is 3.4–17 μmol/L. A result of 33 μmol/L may be the critical value between normal and abnormal state, which needs further examination. A negative result of this test does not mean that urobilinogen is not present in the sample.

2.BIL: under normal circumstances, the presence of bilirubin in urine cannot be detected even using the most sensitive method. The presence of a trace amount of bilirubin in urine will produce positive results, which requires further examination. Certain drug metabolites that show color at lower pH values, such as phenazopyridine, will interfere with the detection of bilirubin. A high concentration of Vitamin C may lead to false negative results in samples with bilirubin

Urinalysis Strip (Dry Chemistry Method)

concentration around 17 $\mu\text{mol/L}$.

3.KET: the reagent of this part reacts with acetoacetic acid in urine, not with acetone or β -hydroxybutyric acid. Normal urine will generally only give negative results. False positive results may be produced from urine samples containing pigments or large amounts of levodopa metabolites.

4.LEU: this strip reacts with esterases in leukocytes (neutrophils), and the normal urine samples produce negative test results. A single critical result is clinically dubious; however, if such result appears repeatedly, it is indicative of highly clinical significance. Due to the contamination of vaginal excretions, a positive result is occasionally obtained in randomly selected female urine samples. The high specific gravity urine will produce lower test results.

5.NIT: nitrite reductase in Gram-negative bacterium in urine will reduce nitrate (extracted from food) to nitrite. This test is specific to nitrite, which doesn't react with other substances excreted in normal urine. Pink spots or lines shall not be determined as positive, while any pink coloration shall be determined as a positive result, indicating the presence of 100,000 or more Gram-negative bacteria per milliliter in the sample. However, the degree of coloration is not proportional to the number of cells present, and the negative result doesn't confirm the absence of a large number of cells. Negative results may appear in the following situations: the facts that the urine does not contain reductase microorganisms that can cause the nitrate-to-nitrite conversion, the diet lacks nitrate, and the urine does not remain in the bladder for more than 4 hours, result in the impossibility to complete the nitrate-to-nitrite conversion. The reactivity of this test will be reduced for high-specific-gravity urine samples. When Vitamin C concentration is $\geq 1.4\text{mmol/L}$, samples with nitrite concentration around 0.125mg/dL may show false negative results.

6.PRO: although the protein test area is more sensitive to albumin than globulin, hemoglobin, Bence-Jones protein and mucoprotein, a "negative" result cannot rule out the existence of these proteins. Normal people will excrete a small amount of protein, which cannot be detected by general normal methods. If the color is deeper than "±", it means that the urine contains protein. False-positive results may be caused by highly buffered alkaline urine, or if the urine sample is contaminated with a quaternary ammonium compound, or a certain preservative or detergent.

7.BLD: the critical reaction has different meanings for different patients. For a rare case, its determination requires clinical examination before a definite diagnosis can be made. If green spots (intact erythrocytes) and green color (hemoglobin/myoglobin) appear in the reaction zone within 60 seconds of adding the sample, this then means that the patient needs to be further examined. This test is very sensitive to blood erythrocytes, so it can be used to supplement microscopy. The sensitivity of this strip is slightly lower for high-specific-gravity urine, and this strip has the same sensitivity for hemoglobin and myoglobin. Certain oxidizing contaminants, for example hypochlorite can cause false positive results. Discharge that accompanies a urinary tract infection can also cause false-positive results. The result of blood test with urine from menstrual females is usually positive. When Vitamin C concentration is $\geq 1.4\text{mmol/L}$, samples with blood concentration around 10Ery/ μL may show false negative results.

8.CRE: the creatinine concentration in normal adult urine is 0.6–2.0 g/24 hours (the test result of the strip is about 4.4–17.7 mmol/L), and the creatinine test result of random urine samples varies greatly, within the range of 0.9–26.5mmol/L. The content in concentrated urine and morning urine is higher (the test result of the strip may be higher than 17.7mmol/L); urine dilution due to polyuria, excessive drinking of water or other conditions will result in typical low-concentration urine.

9.mALB: this test area is used for the detection of urinary albumin. A 150 mg/L test result indicates clinical proteinuria. The microalbumin strip can sensitively detect albumin in urine, and its sensitivity to other proteins is nine times lower than that to albumin.

10.GLU: this test area is specific to glucose. Only glucose in urine will produce positive result. When Vitamin C concentration $\geq 2.8\text{ mmol/L}$ and acetoacetic acid $\geq 1.0\text{ mmol/L}$, samples with glucose concentrations around 2.8 mmol/L may have false-negative results. Under normal circumstances a small amount of glucose may be discharged through the kidney, and usually such a small amount is below the sensitivity of this strip test.

11.SG: this reaction zone can be used to detect the specific gravity between 1.000 and 1.030 in urine. Generally, the error between the result of this test and the result obtained using the refraction coefficient method is within 0.005. In order to improve its accuracy, when the pH value of urine is equal to or greater than 6.5, 0.005 shall be added to the visual reading of urine specific gravity. The urine chemistry analyzer automatically makes adjustment for this when reading the strip. The test is not affected by some of the non-ionic components in the urine, such as glucose, and is also not affected by opaque dyes. Highly buffered alkaline urine will give lower readings under this method than other methods. When the urine contains protein (1 g/L–7.5 g/L), the specific gravity reading can be on the high side.

12.pH: the measurement range of the pH is 5.0–9.0.

13.Vc: this test area is used to detect ascorbic acid in urine. Through the test of this item, the level of ascorbic acid in the human body can be known, and the impact of ascorbic acid on bilirubin, nitrite, blood, and glucose test results can be evaluated.

14.Ca: when a large amount of magnesium ion ($>10\text{ mmol/L}$) exists, the test result will be on the high side or even false positive.

Performance characteristics

- Accuracy: the difference between the test result and the label value of the corresponding reference shall not exceed one order of magnitude in the same direction, and there shall be no reverse difference. Negative results must not appear with the positive reference, and positive results shall not appear with the negative reference.
- Repeatability: the consistency of test result shall not be less than 90%.
- Limit of detection: the first non-negative magnitude shall be detectable for each test item except for specific gravity and pH.

Limitations

- This product can only be used for the measurement of urine, not for that of samples of other body fluids.

Urinalysis Strip (Dry Chemistry Method)

2. pH: for samples that exceed the linear range, it may not be possible to find a corresponding block of similar color.

3. This product is for semi-quantitative or qualitative detection only. The limit of detection is set and verified according to the actual situation when using the product. The limit of detection for URO, CRE, mALB, and Ca is the concentration corresponding to the first order of magnitude. The limit of detection for other items is the concentration corresponding to the first non-negative magnitude. The specific limit of detection of each test item is shown in the following table:

Test item	Limit of detection	Test item	Limit of detection	Test item	Limit of detection
URO	3.4 $\mu\text{mol/L}$	PRO	15 mg/dL	SG	/
BIL	17 $\mu\text{mol/L}$	BLD	10 Ery/ μL	pH	/
KET	0.5 mmol/L	CRE	0.9mmol/L	Vc	0.6 mmol/L
LEU	15 Leu/ μL	mALB	10 mg/L	Ca	1.0 mmol/L
NIT	0.125mg/dL	GLU	2.8 mmol/L	/	/

Technical assistance

For customer support, contact your local technical support provider or distributor.

Symbol interpretation

Symbol	Title and Description	Symbol	Title and Description
	In vitro diagnostic medical device		Use-by date
	Batch code		Temperature limit
	Consult instructions for use		Do not re-use
	Date of manufacture		Keep away from sunlight
	Catalogue number		Contains sufficient for <n> tests
	CE marking of conformity		Manufacturer
	Authorized Representative in the European Community		

References

- Urinalysis and Collection, Transportation, and Preservation of Urine Specimens; Approved Guideline—Third Edition, from NCCLS Document GP16-A, 2009.
- Cong Yulong, Ma Junlong, etc. Modern Urinalytic Technology and Clinic Application, China Science and Technology Press, 1998.
- Cong Yulong, Ma Junlong, etc. Practical Urinalysis Technology and Clinical Application, People's Health Publishing House, first edition, September, 2013.



Zybio Inc.
Floor 1 to Floor 5, Building 30, No.6 of Taikang Road, Block C of Jianqiao Industrial Park, Dadukou District, 400082 Chongqing, PEOPLE'S REPUBLIC OF CHINA
Tel: +86 (0)23 68959999
Fax: +86 (0)23 68699779
E-mail: info@zybio.com
Web: www.zybio.com



Lotus NL B.V.
Koningin Julianaplein 10, 1e Verd, 2595AA, The Hague, Netherlands.

IFU Revision: 02 Release date: 2022-05-20

Focusing Fluid

Specifications

REF	Specifications
01.09.1F.01.09.04	60 mL/Bottle
01.09.1F.01.09.03	125 mL/Bottle

Intended purpose

This product is used to determine the position of focal plane of microscopic imaging system in the urine sediment analyzer or the urinalysis hybrid system.

Test principles

It is based on the principle of flow microscopy imaging. The particles in the sample pass through the thin-layer structure of the flow cell of the instrument, and the shooting area of sediment is illuminated by a high-frequency light source after being shaped by the lighting component. At the same time, the camera takes pictures at the same frequency to form sediment images, which are then recognized and classified by the instrument. The instrument calculates the concentration of sediment in the sample according to the number of "particles" in the sample and the volume of the urine sample.

Before testing the sample on the instrument, it is necessary to use the focusing fluid to focus the camera of the instrument, so as to adjust the best shooting focal length: when the focusing fluid is used for focusing, the camera automatically adjusts the focal length, adopts different focal lengths to shoot the particles in the focusing fluid, and the best focal length is determined according to the clearest particle image. When the sample is being imaged, the camera will take pictures at the determined optimal focal length to ensure that the particles imaged during the test are clear and easy to identify.

Materials provided

Common component	60 mL	125mL
Focusing Fluid	1 bottle	1 bottle
Element	mouse blood	
Instructions for use	1 pc	1 pc

Note: this product is batch-specific. For the detailed target value, see the product label of each batch. Calibrators from different batches cannot be used together.

Materials required (but not provided)

Urine analyzer, general laboratory equipment.

Storage and stability

1. Unopened: the validity period is 12 months when stored under 2–8°C and kept away from sunlight. The product can't be stored under frozen conditions.
2. Opened: the validity period is 30 days when stored under 2–8°C and kept away from sunlight. The product can't be stored under frozen conditions.
3. See packaging label for date of manufacture and expiry date.

Applicable instruments

Zybio Urine sediment analyzer (model: U2600, U2601, U2602, U2610, U2611, U2612), and Urinalysis hybrid system (model: U3600, U3601, U3602)

Assay procedure

Please follow the instructions of this product and the instructions of the applicable instruments.

1. Focusing should be performed at the restart of the instrument or before the test every day.
2. Gently invert it several times to homogenize it.
3. During test with urine sediment analyzer/urinalysis hybrid system: set the instrument at focus status. Pour the focusing fluid into a dry and clean test tube. Place the test tube on the target position of the instrument for focusing.
4. If the focusing fails, the user shall check the detection system, please check whether the focusing fluid is expired and whether the instrument works normally.

Performance characteristics

1. Accuracy: the particle content of the focusing fluid is 1,500 pcs/μL–2,000 pcs/μL, and the relative deviation should be less than or equal to 7.0%;
2. Homogeneity:
 - 2.1 Within-bottle homogeneity: $CV_{\text{within-bottle}} \leq 15\%$;
 - 2.2 Between-bottle homogeneity: the between-bottle homogeneity of the counting results shall be good.











Precautions

1. This product is can be only used to determine of focal plane position of microscopic imaging system of the urine sediment analyzer or urinalysis hybrid system. Do not use it for other purposes.
2. Avoid contact with the skin and eyes. If this product is splashed into eyes, rinse with running warm water for several minutes; seek medical attention immediately if pain or swelling occurs. In case of contact with skin, rinse with soapy water, and completely rinse off the product with clean water.
3. Please use this product as required by the instructions. The accuracy of the results cannot be guaranteed for purposes other than the prescribed instructions and intended purpose.
4. Routine precautions for laboratory operations must be followed when this product is used.
5. The focusing fluid disposal and the containers that have been in contact with the control shall follow the relevant waste regulations such as medical waste or industrial waste. All waste shall be treated as a potential infection source.
6. The focusing fluid that was opened shall be sealed and stored as instructed, and do not use expired product.
7. This product shall be stored as instructed, and kept away from direct sunlight during operation.

Symbol interpretation

Symbol	Title and Description	Symbol	Title and Description
--------	-----------------------	--------	-----------------------

Focusing Fluid

	In vitro diagnostic medical device		Date of manufacture
	Batch code		Use-by date
	Consult instructions for use		Temperature limit
	Keep away from sunlight		Catalogue number
	CE mark of conformity		Manufacturer
	Authorized Representative in the European Community		

References

1. Urinalysis and Collection, Transportation, and Preservation of Urine Specimens; Approved Guideline—Third Edition, from NCCLS Document GP16-A, 2009.
2. Cong Yulong, Ma Junlong, et al. Modern Urinalytical Technology and Clinic Application, China Science and Technology Press, 1998.
3. Cong Yulong, Ma Junlong, et al. Practical Urinalytical Technology and Clinical Application, People's Health Publishing House, first edition, September, 2013.

Zybio Inc.

Floor 1 to Floor 5, Building 30, No.6 of Taikang Road, Block C of Jianqiao Industrial Park, Dadukou District, 400082 Chongqing, PEOPLE'S REPUBLIC OF CHINA

Tel: +86 (0)23 68959999

Fax: +86 (0)23 68699779

E-mail: info@zybio.com

Web: www.zybio.com



Lotus NL B.V.

Koningin Julianaplein 10, 1e Verd, 2595AA, The Hague, Netherlands.

IFU Revision: 02 Release date: 2022-05-20

Color Control

Specifications

REF	Specifications
01.09.1F.01.04.04	Control (Red): 1×8 mL
01.09.1F.01.04.05	Control (Green): 1×8 mL
01.09.1F.01.04.06	Control (Blue): 1×8 mL
01.09.1F.01.04.03	Control (Red, Green, Blue): 3×8 mL

Intended purpose

This product is applicable to the QC test of urine chemistry analyzer and urinalysis hybrid system.

Test principles

The QC of the test system is performed by measuring a control of with a known concentration, so as to ensure the reliability of the results of from the instrument.

Materials provided

Common component	RED	GREEN	BLUE	3-color
Color control	1bottle	1bottle	1bottle	3bottles
Instructions for use	1 pc	1 pc	1 pc	1 pc

Note: Products of different batches cannot be used together.

Materials required (but not provided)

Urine analyzer, general laboratory equipment.

Storage and stability

1. Unopened: the validity period is 12 months when stored under 2-8°C and kept away from sunlight. The product can't be stored under frozen conditions.
2. Opened: the validity period is 30 days when stored under 2-8°C and kept away from sunlight. The product can't be stored under frozen conditions.
3. See packaging label for date of manufacture and expiry date.

Applicable instruments

Zybio Urine chemistry analyzer (model: U1600, U1601, U1602), Urinalysis hybrid system (model: U3600, U3601, U3602).

Assay procedure

Refer to the instructions on this product and the instructions on compatible instruments.

1. The QC test shall be performed before the instrument restart or daily test, and controls 2 levels or more shall be used for QC as much as possible.
2. Before use, leave the control under room temperature for 30 minutes.
3. To use it, gently invert it several times to homogenize it.
4. During test with urine chemistry analyzer: put the instrument at QC status. Pour the control into a dry and

clean test tube. Place the test tube at a test position in a compatible instrument for testing.

5. The test result shall be consistent with the indicated result. If not consistent, the user shall check the detection system, such as the validity period of the control, performance and status of instrument, etc.

Performance characteristics











Test value: the test result is the same as the indicated value.

Uniformity: consistency of test results $\geq 90\%$.

Precautions

1. This product is only applicable to the QC test of color module of urine chemistry analyzer or urinalysis hybrid system, and shall not be used for other purposes.
2. Avoid contact with the skin and eyes. If this product is splashed into the eyes, rinse with running warm water for several minutes; seek medical attention immediately if pain or swelling occurs. In case of contact with skin, rinse with soapy water, and completely rinse off the product with clean water.
3. Please use this product as required by the instructions. The accuracy of the results cannot be guaranteed for purposes other than the prescribed instructions and intended purpose.
4. Routine precautions for laboratory operations must be followed when this product is used.
5. The control disposal and the containers that have been in contact with the control shall follow the relevant waste regulations such as medical waste or industrial waste. All waste shall be treated as a potential infection source.
6. The control that was opened shall be sealed and stored according to the specified method; do not use expired products.
7. Please keep this product according to the storage method, and avoid direct sunlight during operation.

Symbol interpretation

Symbol	Title and Description	Symbol	Title and Description
	In vitro diagnostic medical device		Date of manufacture
	Batch code		Use-by date
	Consult instructions for use		Temperature limit
	Keep away from sunlight		Catalogue number
	CE marking of conformity		Manufacturer
	Authorized Representative in the European Community		

Color Control

References

1. Urinalysis and Collection, Transportation, and Preservation of Urine Specimens; Approved Guideline—Third Edition, from NCCLS Document GP16-A, 2009.
2. Cong Yulong, Ma Junlong, et al. Modern Urinalytical Technology and Clinic Application, China Science and Technology Press, 1998.
3. Cong Yulong, Ma Junlong, et al. Practical Urinalytical Technology and Clinical Application, People's Health Publishing House, first edition, September, 2013.



Zybio Inc.

Floor 1 to Floor 5, Building 30, No.6 of Taikang Road,
Block C of Jianqiao Industrial Park, Dadukou District,
400082 Chongqing, PEOPLE'S REPUBLIC OF CHINA
Tel: +86 (0)23 6895 9999
Fax: +86 (0)23 6869 9779
E-mail: info@zybio.com
Web: www.zybio.com



Lotus NL B.V.

Koningin Julianaplein 10, 1e Verd, 2595AA, The
Hague, Netherlands.

IFU Revision: 02 Release date: 2022-05-20

SG Calibrator

Specifications

REF	Specifications
01.09.1F.01.15.02	3 levels × 1 × 8 mL

Intended purpose

This product is used for calibration of the SG module of urine chemistry analyzer and urinalysis hybrid system.

Test principles

The calibrator of a known concentration is measured for the purpose of calibration on the detection system, so as to establish the metrological traceability of the measurement result obtained from that system.

Materials provided

Common component	3 levels
SG Calibrator	3 bottles
Instructions for use	1 pc

Note:

Indicated value	Uncertainty
See bottle label	See bottle label

Traceability: traceable to enterprise reference.

Materials required (but not provided)

Urine analyzer, general laboratory equipment.

Storage and stability

1. Unopened: the validity period is 12 months when stored under 2–8°C and kept away from light.
2. Opened: the validity period is 7 days when stored under 2–8°C and kept away from light.
3. See packaging label for date of manufacture and expiry date.

Applicable instruments

Zybio Urine chemistry analyzer (model: U1600, U1601, U1602), Urinalysis hybrid system (model: U3600, U3601, U3602).

Assay procedure

Please follow the instructions of this product and the instructions of the applicable instruments.

1. Calibration shall be performed in case of invalid control for instrument or based on a monthly interval. Calibrators of 3 levels must be used.
2. Before use, leave the control under room temperature for 30 minutes.
3. Gently invert it several times to homogenize it.
4. During test with urine chemistry analyzer: set the instrument at calibration status. Pour the calibrator all into a dry and clean test tube. Place the test tube on the target position for calibration of the instrument.
5. After the calibration is completed, the instrument will display successful calibration. If the calibration has failed, please check whether the calibrator is expired and whether the instrument works normally.

Performance characteristics

Accuracy: correctness of measuring value transfer $|En| \leq 1$.











Homogeneity:

- 1) CV_{within-bottle} ≤ 5%;
- 2) CV_{between-bottle} ≤ 5%.

Precautions

1. This product is only applicable to the calibration of SG module of urine chemistry analyzer or urinalysis hybrid system. Please do not use it for other purposes.
2. The value assignment of calibrators varies with different batches. See bottle label for specific indicated value.
3. Avoid contact with the skin and eyes. If this product is splashed into the eye, rinse with running warm water for several minutes; seek medical attention immediately if pain or swelling occurs. In case of contact with skin, rinse the skin with soapy water, and completely rinse off the product with clean water.
4. Please use this product as required by the instructions. The accuracy of the results cannot be guaranteed for purposes other than the prescribed instructions and intended purpose.
5. Routine precautions for laboratory operations must be followed when using it.
6. The calibrator disposal and the containers that have been in contact with the control shall follow the relevant waste regulations such as medical waste or industrial waste. All waste shall be treated as a potential infection source.
7. The calibrator that was opened shall be sealed and stored as instructed, and do not use expired product.
8. This product shall be stored as instructed, and kept away from direct sunlight during operation.

Symbol interpretation

Symbol	Title and Description	Symbol	Title and Description
	In vitro diagnostic medical device		Date of manufacture
	Batch code		Use-by date
	Consult instructions for use		Temperature limit
	Keep away from sunlight		Catalogue number
	CE marking of conformity		Manufacturer
	Authorized Representative in the European Community		

References

1. Urinalysis and Collection, Transportation, and Preservation of Urine Specimens; Approved Guideline—Third Edition, from NCCLS Document GP16-A, 2009.

SG Calibrator

2. Cong Yulong, Ma Junlong, et al. Modern Urinalytical Technology and Clinic Application, China Science and Technology Press, 1998.

3. Cong Yulong, Ma Junlong, et al. Practical Urinalytical Technology and Clinical Application, People's Health Publishing House, first edition, September, 2013.

Zybio Inc.

Floor 1 to Floor 5, Building 30, No.6 of Taikang Road, Block C of Jianqiao Industrial Park, Dadukou District, 400082 Chongqing, PEOPLE'S REPUBLIC OF CHINA

Tel: +86 (0)23 68959999

Fax: +86 (0)23 68699779

E-mail: info@zybio.com

Web: www.zybio.com



Lotus NL B.V.

Koningin Julianaplein 10, 1e Verd, 2595AA, The Hague, Netherlands.

IFU Revision: 02 Release date: 2022-05-20

SG Control

Specifications

REF	Specifications
01.09.1F.01.05.04	Level 1: 1 × 8 mL
01.09.1F.01.05.05	Level 2: 1 × 8 mL
01.09.1F.01.05.06	Level 3: 1 × 8 mL
01.09.1F.01.05.03	3 levels × 1 × 8 mL

Intended purpose

This product is used for the QC test of SG module of urine chemistry analyzer and urinalysis hybrid system.

Test principles

The QC of the test system is performed by measuring a control of with a known concentration, so as to ensure the reliability of the results of the instrument.

Materials provided

Common component	Level 1	Level 2	Level 3	3 levels
SG control	1bottle	1bottle	1bottle	3bottles
Instructions for use	1 pc	1 pc	1 pc	1 pc

Note: The control value assigned for different batches is slightly different and has batch specificity. For details, please refer to the attached table of the product. Controls from different batches cannot be mixed.

Materials required (but not provided)

Urine analyzer, general laboratory equipment.

Storage and stability

- Unopened: the validity period is 12 months when stored under 2-8°C and kept away from sunlight. The product can't be stored under frozen conditions.
- Opened: the validity period is 30 days when stored under 2-8°C and kept away from sunlight. The product can't be stored under frozen conditions.
- See packaging label for date of manufacture and expiry date.

Applicable instruments

Zybio Urine chemistry analyzer (model: U1600, U1601, U1602), Urinalysis hybrid system (model: U3600, U3601, U3602).

Assay procedure

Please follow the instructions of this product and the instructions of the applicable instruments.

- The QC test shall be performed at the instrument restart or before starting test every day, and controls of more than 2 levels shall be used for QC as much as possible.
- Before use, leave the control under room temperature for 30 minutes.
- Gently invert it several times to homogenize it.
- During test with urine chemistry analyzer: set the

instrument at QC status. Pour the control into a dry and clean test tube. Place the test tube on the target position for QC testing of the instrument.

5. The test result shall be within the indicated value range. If it is beyond the range, please check whether the control is expired and whether the instrument works normally.











Performance characteristics

Test value: test results shall be within the indicated range. Homogeneity: the CV_{between-bottle} ≤ 5%.

Precautions

- This product is only applicable to the QC of SG module of urine chemistry analyzer or urinalysis hybrid system. Please do not use it for other purposes.
- Avoid contact with the skin and eyes. If this product is splashed into the eyes, rinse with running warm water for several minutes; seek medical attention immediately if pain or swelling occurs. In case of contact with skin, rinse with soapy water, and completely rinse off the product with clean water.
- Please use this product as required by the instructions. The accuracy of the results cannot be guaranteed for purposes other than the prescribed instructions and intended purpose.
- Routine precautions for laboratory operations must be followed when this product is used.
- The control disposal and the containers that have been in contact with the control shall follow the relevant waste regulations such as medical waste or industrial waste. All waste shall be treated as a potential infection source.
- The control that was unsealed shall be sealed and stored as instructed; do not use expired products.
- This product shall be stored as instructed, and kept away from direct sunlight during operation.

Symbol interpretation

Symbol	Title and Description	Symbol	Title and Description
	In vitro diagnostic medical device		Date of manufacture
	Batch code		Use-by date
	Consult instructions for use		Temperature limit
	Keep away from sunlight		Catalogue number
	CE marking of conformity		Manufacturer
	Authorized Representative in the European Community		

SG Control

References

1. Urinalysis and Collection, Transportation, and Preservation of Urine Specimens; Approved Guideline—Third Edition, from NCCLS Document GP16-A, 2009.
2. Cong Yulong, Ma Junlong, et al. Modern Urinalytical Technology and Clinic Application, China Science and Technology Press, 1998.
3. Cong Yulong, Ma Junlong, et al. Practical Urinalytical Technology and Clinical Application, People's Health Publishing House, first edition, September, 2013.



Zybio Inc.
Floor 1 to Floor 5, Building 30, No.6 of Taikang Road, Block C of Jianqiao Industrial Park, Dadukou District, 400082 Chongqing, PEOPLE'S REPUBLIC OF CHINA
Tel: +86 (0)23 68959999
Fax: +86 (0)23 68699779
E-mail: info@zybio.com
Web: www.zybio.com



Lotus NL B.V.
Koningin Julianaplein 10, 1e Verd, 2595AA, The Hague, Netherlands.

IFU Revision: 02 Release date: 2022-05-20

Turbidity Calibrator

Specifications

REF	Specifications
01.09.1F.01.16.02	2 levels×1×8 mL

Intended purpose

This product is used for calibration of the turbidity module of urine chemistry analyzer and urinalysis hybrid system.

Test principles

The calibrator of a known concentration is measured for the purpose of calibration on the detection system, so as to establish the metrological traceability of the measurement result of this system.

Materials provided

Common component	2 Levels
Turbidity Calibrator	2 bottles
Instructions for use	1 pc

Note:

Indicated value	Uncertainty
See bottle label	See bottle label

Traceability: traceable to GBW12001 standard.

Materials required (but not provided)

Urine analyzer, general laboratory equipment.

Storage and stability

1. Unopened: the validity period is 12 months when stored under 2–8°C and kept away from sunlight.
2. Opened: the validity period is 7 days when stored under 2–8°C and kept away from sunlight.
3. See packaging label for date of manufacture and expiry date.

Applicable instruments

Zybio Urine chemistry analyzer (model: U1600, U1601, U1602), Urinalysis hybrid system (model: U3600, U3601, U3602).

Assay procedure

Please follow the instructions of this product and the instructions of the applicable instruments.

1. Calibration shall be performed in case of invalid control for instrument or based on a monthly interval. Calibrators with 2 levels must be used for calibration.
2. Before use, leave the control under room temperature for 30 minutes.
3. Gently invert it several times to homogenize it.
4. During test with urine chemistry analyzer: set the instrument at calibration status. Pour the calibrator into a dry and clean test tube. Place the test tube on the target position for calibration of the instrument.
5. After the calibration is completed, the instrument will display successful calibration. If the calibration has failed, please check whether the calibrator is expired and whether the instrument works normally.

Performance characteristics











Accuracy: correctness of measuring value transfer $|En| \leq 1$.
Homogeneity:

- 1) CV_{within-bottle} $\leq 5\%$;
- 2) CV_{between-bottle} $\leq 5\%$.

Precautions

1. This product is only applicable to the calibration of turbidity module of urine chemistry analyzer or urinalysis hybrid system. Please do not use it for other purposes.
2. The value assignment of calibrators varies with different batches. See bottle label for specific indicated value.
3. Avoid contact with the skin and eyes. If this product is splashed into eyes, rinse with running warm water for several minutes; seek medical treatment immediately if pain or swelling occurs. In case of contact with skin, rinse the skin with soapy water, and completely rinse off the product with clean water.
4. Please use this product as required in the instructions. The accuracy of the results cannot be guaranteed for purposes other than the prescribed instructions and intended purpose.
5. Routine precautions for laboratory operations must be followed when this product is used.
6. The calibrator disposal and the containers that have been in contact with the control shall follow the relevant waste regulations such as medical waste or industrial waste. All waste shall be treated as a potential infection source.
7. The calibrator that was opened shall be sealed and stored as instructed, and do not use expired product.
8. This product shall be stored as instructed, and kept away from direct sunlight during operation.

Symbol interpretation

Symbol	Title and Description	Symbol	Title and Description
	In vitro diagnostic medical device		Date of manufacture
	Batch code		Use-by date
	Consult instructions for use		Temperature limit
	Keep away from sunlight		Catalogue number
	CE marking of conformity		Manufacturer
	Authorized Representative in the European Community		

References

1. Urinalysis and Collection, Transportation, and Preservation of Urine Specimens; Approved

Turbidity Calibrator

Guideline—Third Edition, from NCCLS Document GP16-A, 2009.

2. Cong Yulong, Ma Junlong, et al. Modern Urinalytical Technology and Clinic Application, China Science and Technology Press, 1998.

3. Cong Yulong, Ma Junlong, et al. Practical Urinalytical Technology and Clinical Application, People's Health Publishing House, first edition, September, 2013.



Zybio Inc.
Floor 1 to Floor 5, Building 30, No.6 of
Taikang Road, Block C of Jianqiao Industrial
Park, Dadukou District, 400082 Chongqing,
PEOPLE'S REPUBLIC OF CHINA
Tel: +86 (0)23 68959999
Fax: +86 (0)23 68699779
E-mail: info@zybio.com
Web: www.zybio.com



Lotus NL B.V.
Koningin Julianaplein 10, 1e Verd, 2595AA,
The Hague, Netherlands.

IFU Revision: 02 Release date: 2022-05-20

Turbidity Control

Specifications

REF	Specifications
01.09.1F.01.06.04	Level 1: 1 × 8 mL
01.09.1F.01.06.05	Level 2: 1 × 8 mL
01.09.1F.01.06.06	Level 3: 1 × 8 mL
01.09.1F.01.06.03	3 levels × 1 × 8 mL

Intended purpose

This product is applicable to the QC test of Urine Chemistry Analyzer and Urinalysis Hybrid System.

Test principles

The QC of the test system is performed by measuring a control with a known concentration, to ensure the reliability of results from the instrument.

Materials provided

Common component	Level 1	Level 2	Level 3	3 levels
Turbidity control	1bottle	1bottle	1bottle	3bottles
Instructions for use	1 pc	1 pc	1 pc	1 pc

Note: the control assigned value of different batches is slightly different and has batch specificity. For details, please refer to the product target value sheet. Reagents from different batches cannot be mixed.

Materials required (but not provided)

Urine analyzer, general laboratory equipment.

Storage and stability

- Unopened: the validity period is 12 months when stored under 2-8°C and kept away from sunlight. The product can't be stored under frozen conditions.
- Opened: the validity period is 30 days when stored under 2-8°C and kept away from sunlight. The product can't be stored under frozen conditions.
- See packaging label for date of manufacture and expiry date.

Applicable instruments

Zybio Urine chemistry analyzer (model: U1600, U1601, U1602), Urinalysis hybrid system (model: U3600, U3601, U3602).

Assay procedure

Refer to the instructions on this product and the instructions on compatible instruments.

- The QC test shall be performed before the instrument restart or daily test, and controls 2 levels or more shall be used for QC as much as possible.
- Before use, leave the control under room temperature for 30 minutes.
- To use it, gently invert it several times to homogenize it.
- During test with urine chemistry analyzer: put the

instrument at QC status, pour the control into a dry and clean test tube, place the test tube at a test position in a compatible instrument for testing.

5. The test result shall be consistent with the indicated result. If not consistent, the user shall check the detection system, such as the validity period of the control, performance and status of instrument, etc.

Performance characteristics











Test value: the test result is the same as the indicated value.

Uniformity: consistency of test results $\geq 90\%$.

Precautions

- This product is only applicable to the QC of turbidity module of urine chemistry analyzer or urinalysis hybrid system. Please do not use it for other purposes.
- Avoid contact with the skin and eyes. If this product is splashed into eyes, flush with running warm water for several minutes; seek medical treatment immediately if pain or swelling occurs. In case of contact with skin, rinse with soapy water, and completely rinse off the product with clean water.
- Please use this product as required by the instructions. The accuracy of the results cannot be guaranteed for purposes other than the prescribed instructions and intended purpose.
- Routine precautions for laboratory operations must be followed when this product is used.
- The control disposal and the containers that have been in contact with the control shall follow the relevant waste regulations such as medical waste or industrial waste. All waste shall be treated as a potential infection source.
- The control that was unsealed shall be sealed and stored as instructed, and do not use expired products.
- This product shall be stored as instructed, and kept away from direct sunlight during operation.

Symbol interpretation

Symbol	Title and Description	Symbol	Title and Description
	In vitro diagnostic medical device		Date of manufacture
	Batch code		Use-by date
	Consult instructions for use		Temperature limit
	Keep away from sunlight		Catalogue number
	CE marking of conformity		Manufacturer
	Authorized Representative in the European Community		

Turbidity Control

References

1. Urinalysis and Collection, Transportation, and Preservation of Urine Specimens; Approved Guideline—Third Edition, from NCCLS Document GP16-A, 2009..
- 2.Cong Yulong, Ma Junlong, et al. Modern Urinalytical Technology and Clinic Application, China Science and Technology Press, 1998.
- 3.Cong Yulong, Ma Junlong, et al. Practical Urinalytical Technology and Clinical Application, People's Health Publishing House, first edition, September, 2013.



Zybio Inc.

Floor 1 to Floor 5, Building 30, No.6 of Taikang Road,
Block C of Jianqiao Industrial Park, Dadukou District,
400082 Chongqing, PEOPLE'S REPUBLIC OF CHINA
Tel: +86 (0)23 6895 9999
Fax: +86 (0)23 6869 9779
E-mail: info@zybio.com
Web: www.zybio.com



Lotus NL B.V.

Koningin Julianaplein 10, 1e Verd, 2595AA, The
Hague, Netherlands.

IFU Revision: 02 Release date: 2022-05-20

Sediment Control

Specifications

REF	Specifications	
01.09.1F.01.08.08	Negative Control	60 mL/Bottle
01.09.1F.01.08.06	Negative Control	125 mL/Bottle
01.09.1F.01.08.07	Positive Control	60 mL/Bottle
01.09.1F.01.08.05	Positive Control	125 mL/Bottle

Intended purpose

This product is applicable to testing process quality control (QC) of urine sediment analyzer or urinalysis hybrid system to ensure the accuracy of the instrument.

Test principles

It is based on the principle of flow microscopy imaging. Particles in the sample pass through the thin-layer structure of the flow cell of the instrument, and the imaging area of the sediment is illuminated by a high-frequency light source after being shaped by the lighting component. At the same time, the camera takes pictures at the same frequency to form sediment images, which are then recognized and classified by the instrument. The instrument calculates the concentration of sediment in the sample (the number of particles per unit volume) according to the number of "particles" in the sample and the volume of the urine sample passing through the flow cell.

After focusing and calibrating the detection instrument, the control for urine sediment analysis is tested as the sample to be tested. The control of known "particle" concentration is used to conduct the QC of detection system, so as to ensure the reliability of measurement results of detection system.

Materials provided

Common component	Negative control	Positive control
Sediment control	1 bottle	1 bottle
Element	PBS	mouse blood
Instructions for use	1 pc	1 pc

Note: the control assigned value of different batches is slightly different and has batch specificity. For details, please refer to the product target value sheet. Reagents from different batches cannot be mixed.

Materials required (but not provided)

Urine analyzer, general laboratory equipment.

Storage and stability

- Unopened: the validity period is 12 months when stored under 2–8°C and kept away from sunlight. The product can't be stored under frozen conditions.
- Opened: the validity period is 30 days when stored under 2–8°C and kept away from sunlight. The product can't be stored under frozen conditions.

- See packaging label for date of manufacture and expiry date.

Applicable instruments

Zybio Urine sediment analyzer (model: U2600, U2601, U2602, U2610, U2611, U2612), and Urinalysis hybrid system (model: U3600, U3601, U3602)

Assay procedure

Please follow the instructions of this product and the instructions of the applicable instruments.

- The QC test shall be performed at the instrument restart or before starting test every day, and both negative and positive controls shall be used for QC as much as possible.
- Gently invert it several times to homogenize it.
- During test with urine sediment analyzer/urinalysis hybrid system: set the instrument at Control status. Pour the control into a dry and clean test tube. Place the test tube on the target position for QC testing of the instrument.
- The test result shall be within the indicated value range. If it is beyond the range, please check whether the control is expired and whether the instrument works normally.

Performance characteristics

- Range of control: for negative control, particle content ≤ 20 pcs/ μ L; for positive control, the relative deviation between the test result and the indicated value shall be within $\pm 5.0\%$.
- Homogeneity:











Level	Requirements
Positive control	$CV_{\text{within-bottle}} \leq 15\%$ The between-bottle homogeneity of between-bottle counting results should be good.

Precautions

- This product is applicable to the calibration of urine. This product is only applicable to the testing process QC of urine sediment analyzer or urinalysis hybrid system. Please do not use it for other purposes.
- Avoid contact with the skin and eyes. If this product is splashed into the eye, rinse it with running warm water for several minutes; seek medical treatment immediately if pain or swelling occurs; in case of contact with skin, rinse the skin with soapy water, and completely rinse off the product with clean water.
- Please use this product as required by the instructions. The accuracy of the results cannot be guaranteed for purposes other than the prescribed instructions and intended purpose.
- Routine precautions for laboratory operations must be followed when this product is used.
- The control disposal and the containers that have been in contact with the control shall follow the relevant waste regulations such as medical waste or industrial waste. All waste shall be treated as a potential infection source.
- The control that was unsealed shall be sealed and stored as instructed; do not use expired products.
- This product shall be stored as instructed, and kept away from direct sunlight during operation.

Sediment Control

Symbol interpretation

Symbol	Title and Description	Symbol	Title and Description
	In vitro diagnostic medical device		Date of manufacture
	Batch code		Use-by date
	Consult instructions for use		Temperature limit
	Keep away from sunlight		Catalogue number
	CE marking of conformity		Manufacturer
	Authorized Representative in the European Community		

References

1. Urinalysis and Collection, Transportation, and Preservation of Urine Specimens; Approved Guideline—Third Edition, from NCCLS Document GP16-A, 2009.
2. Cong Yulong, Ma Junlong, et al. Modern Urinalytical Technology and Clinic Application, China Science and Technology Press, 1998.
3. Cong Yulong, Ma Junlong, et al. Practical Urinalytical Technology and Clinical Application, People's Health Publishing House, first edition, September, 2013.

Zybio Inc.

Floor 1 to Floor 5, Building 30, No.6 of Taikang Road, Block C of Jianqiao Industrial Park, Dadukou District, 400082 Chongqing, PEOPLE'S REPUBLIC OF CHINA
 Tel: +86 (0)23 68959999
 Fax: +86 (0)23 68699779
 E-mail: info@zybio.com
 Web: www.zybio.com



Lotus NL B.V.
 Koningin Julianaplein 10, 1e Verd, 2595AA, The Hague, Netherlands.

IFU Revision: 02 Release date: 2022-05-20

Sheath Fluid

Product name
Sheath Fluid

Package specifications	
REF	Specifications
01.09.1F.01.11.11	10 L/Bucket
01.09.1F.01.11.12	15 L/Bucket
01.09.1F.01.11.13	20 L/Bucket

Intended purpose
The product is used for diluting urine samples to form sheath flow, which is conducive to cell counting and classification by analytical instruments. It should be used by healthcare professionals and properly trained personnel.

Main components
Sodium azide: 0.05%-0.1%.
Polyoxyethylene lauryl ether: 0.1%-1%.
Ethylenediaminetetraacetic acid: 0.01%-0.2%.
Sodium chloride: 0.3%-3%.
Trometamol: 0.01%-0.2%.
Tri (hydroxymethyl) aminomethane hydrochloride: 0.1%-0.5%.

Materials provided

Common component	10L	15 L	20 L
Sheath Fluid	1 Bucket	1 Bucket	1 Bucket
Instructions for use	1 pc	1 pc	1 pc
CPU Card	1 pc	1 pc	1 pc

Operating principle
The sheath fluid used by the analytical system in the testing process is an isotonic, particle-free, buffered solution, which can ensure that the formed particles of the urine sample always flow in a monolayer and independent manner. Flow cytometry is used to ensure that each formed particle flows from the microscope lens and the CCD camera within the focus range of the microscope lens, and then is captured and imaged at high speed.

Storage and stability
1. Validity period: 12 months if sealed and stored at 4°C-30°C, dry, and kept away from sunlight, sealed; 60 days after opening if stored at 4°C-30°C, and kept away from sunlight.
2. See the label for the manufacture date and expiry date.

Applicable instruments
Urine sediment analyzer (model: U2600, U2601, U2602, U2610, U2611, U2612), and Urinalysis hybrid system (model: U3600, U3601, U3602) manufactured by Zybio Inc.







Other models shall be used after verification.

Usage
The CPU card is used for replenishing the sheath fluid volume in the instrument.
1. Press the dot-lined round part on the packaging box of sheath fluid to open a round hole on the packaging box.
2. Pull up the container lid with the container neck stuck by the round hole.
3. Rotate to open the lid, keep the lid retained to prohibit foreign matter from entering the container.
4. Insert the sheath fluid sensor upright into the sheath fluid container. Tight the container lid of the sensor onto the container mouth.
5. Open the charging interface of the CPU of the lower computer software, Insert the CPU card into the card reading port of the host.
6. Pop out the charging confirmation interface of the sheath liquid card, and click OK, that is, the charging is complete.
For more details, refer to the operation manual for applicable instruments.







Performance characteristics
1. pH: 7.50 ± 0.50.
2. Conductivity: 9-15 mS/cm.
3. Osmolarity: 200-300 mOsmol/kg.
4. Particle counting: less than 8 on the average, and no more than 15 on the maximum.

Warnings and precautions
1. Instructions for use must be carefully followed. It is for in vitro diagnostic use only.
2. If the sheath fluid contacts the mouth or eyes or skin, rinse immediately with water and seek medical advice if necessary.
3. The disposal of liquid waste should be by local laws and regulations.
4. Check before use, and do not use in case of flocculent precipitation, turbidity, and other pollution phenomena.
5. Do not use it after being exposed to the air with the cap opened or in direct sunlight for a long time.
6. This product does not contain human components but contains chemical components, which may have potential risks of hazardous chemicals. Appropriate protective measures shall be taken during sample collection, treatment, storage, and testing.

Symbol Interpretation

Symbol	Title and Description	Symbol	Title and Description
	In vitro diagnostic medical device		Batch code
	Consult instructions for use		Use-by date
	CE marking of conformity		Manufacturer

Sheath Fluid

	Authorized Representative in the European Community		Temperature limit
	Catalogue number		Keep away from sunlight
	Date of manufacture		Warning

References

1. Urinalysis and Collection, Transportation, and Preservation of Urine Specimens; Approved Guideline—Third Edition, from NCCLS Document GP16-A, 2009.
2. Cong Yulong, Ma Junlong, et al. Modern Urinalytical Technology and Clinic Application, China Science and Technology Press, 1998.



Zybio Inc.
 Floor 1 to Floor 5, Building 30, No.6 of Taikang Road, Block C of Jianqiao Industrial Park, Dadukou District, 400082 Chongqing, PEOPLE' S REPUBLIC OF CHINA
 Web: www.zybio.com
 E-mail: info@zybio.com
 Tel: +86 (0) 6895 9999
 Fax: +86 (0) 6869 9779



Lotus NL B.V.
 Koningin Julianaplein 10, 1e Verd, 2595AA, The Hague, Netherlands.

Current Revision and Release Date: 03, 2022-11

UDC-Control

Specifications

REF	Specifications
01.09.1F.01.03.05	Negative: 8 mL×1;
01.09.1F.01.03.06	Positive: 8 mL×1;
01.09.1F.01.03.04	Negative: 8 mL×1; Positive: 8 mL×1

Intended purpose

The product is applicable to the QC of the urine chemistry analyzer and urinalysis hybrid system. QC can be performed on analysis strips and instruments for 13 test items, i.e., urobilinogen (URO), bilirubin (BIL), ketone (KET), leukocyte (LEU), nitrite (NIT), protein(PRO), blood(BLD), microalbumin(mALB), creatinine (CRE), glucose(GLU), specific gravity (SG), pH, and calcium (Ca).

Test principles

The urobilinogen substitute, bilirubin substitute, ketone substitute, leukocyte substitute, nitrite, protein, ionic, erythrocyte substitute, glucose, creatinine, calcium, etc. contained in the urine can react chemically with the urinalysis strip, which makes the strip color change.

Materials provided

Common component	Negative control	Positive control	Combination
UDC-Control	1 bottle	1 bottle	2 bottles
Instructions for use	1 pc	1 pc	1 pc

Note: Control target values are batch-specific.

Materials required (but not provided)

Urine analyzer, general laboratory equipment.

Precautions

- Before use, please restore the control to 18-30°C, and invert the bottle several times to homogenize it.
- When using, avoid contact with the eye and skin; if accidentally in contact, please rinse with water immediately; tighten the cap immediately after use and store it at 2-8°C.
- The control is only used by personnel with professional skills in medical and health departments and laboratories. It is only applicable to daily indoor QC and external quality assessment, but not so to calibration as calibrators.
- The test tube containing the control shall be clean and dry to prevent residual detergent or other substances from interfering with the measurement result.
- The urine chemistry analyzer shall use matching urinalysis strips to ensure the accuracy of QC.
- The user shall not touch the reagent part of the urinalysis strip used for QC. The urinalysis strip slot shall be kept clean to prevent the reagent block from being contaminated and affecting the QC result. During the test, the urinalysis strip shall be placed at the correct position in strip slot to avoid deviation of test results.

Storage and stability

1. Unopened: the validity period is 12 months when stored under 2-8°C and kept away from sunlight. The product can't be stored under frozen conditions.
2. Opened: the validity period is 30 days when stored under 2-8°C and kept away from sunlight.
3. See packaging label for date of manufacture and expiry date.

Applicable instruments

Zybio Urine analyzer (model: EXU300, EXU500), Urine chemistry analyzer (model: U1600, U1601, U1602), Urinalysis hybrid system (model: U3600, U3601, U3602).

Assay procedure

1. The controls shall be restored to room temperature and mixed by gently inverting the bottle a few times before use.
2. During a test with a semi-automated urine chemistry analyzer: take out the control. Homogenize the control until it is restored to the environmental temperature. Pour an appropriate amount of the control into a dry and clean test tube. Completely immerse the prepared urinalysis strip into the urine control inside. Soak the strip and take it out (if the method of giving the sample in a dropping bottle is used, drop the homogenized control on the urinalysis strip, and ensure that the urine test strip is soaked). Use filter paper (or other strongly absorbent paper) to absorb excess urine control on the test strip, and then put the strip on the urinalysis strip slot correctly for testing.
3. When testing with a urine chemistry analyzer: put the instrument at QC status. Pour the control into a dry and clean test tube. Place the test tube at a test position in a compatible instrument for testing.

Interpretation of test result

1. Testing under too high or too low temperature outside of the 10°C-30°C range, or in an environment with excessive humidity ($\geq 80\%$ RH), the QC results may deviate from the QC range.
2. When operating strictly according to the operation manual, if the result exceeds the QC range in the attached table, it suggests that the control over urine chemistry analyzer and the supporting urinalysis strip test system may be invalid. If the factor of the QC material is then excluded, the control over the test system can be considered as invalid.

Performance characteristics











Control test value: the test result of each item shall be within the target value range.

Limitations

The bilirubin and urobilinogen in the control are substituted by chemicals; the strip reacts with them to render color, and this color is slightly different from that rendered with the direct bilirubin and urobilinogen in urine.

UDC-Control

Symbol interpretation

Symbol	Title and Description	Symbol	Title and Description
	In vitro diagnostic medical device		Date of manufacture
	Batch code		Use-by date
	Consult instructions for use		Temperature limit
	Keep away from sunlight		Catalogue number
	CE marking of conformity		Manufacturer
	Authorized Representative in the European Community		

References

1. Urinalysis and Collection, Transportation, and Preservation of Urine Specimens; Approved Guideline—Third Edition, from NCCLS Document GP16-A, 2009.
2. Cong Yulong, Ma Junlong, et al. Modern Urinalytical Technology and Clinic Application, China Science and Technology Press, 1998.



Zybio Inc.
 Floor 1 to Floor 5, Building 30, No.6 of Taikang Road, Block C of Jianqiao Industrial Park, Dadukou District, 400082 Chongqing, PEOPLE'S REPUBLIC OF CHINA
 Tel: +86 (0)23 68959999
 Fax: +86 (0)23 68699779
 E-mail: info@zybio.com
 Web: www.zybio.com



Lotus NL B.V.
 Koningin Julianaplein 10, 1e Verd, 2595AA, The Hague, Netherlands.

IFU Revision: 02 Release date: 2022-05-20

US-Calibrator

Specifications

REF	Specifications
01.09.1F.01.10.05	30 mL/Bottle
01.09.1F.01.10.04	60 mL/Bottle
01.09.1F.01.10.03	125 mL/Bottle

Intended purpose

This product is applicable to the calibration of urine sediment analyzer or urinalysis hybrid system to ensure the accuracy of the instrument.

Test principles

It is based on the principle of flow microscopy imaging. The particles in the sample pass through the thin-layer structure of the flow cell of the instrument with the thickness of monolayer cell, and the imaging area of the sediment is illuminated by a high-frequency light source after being shaped by the lighting component. At the same time, the camera takes pictures at the same frequency to form sediment images, which are then recognized and classified by the instrument. The instrument calculates the concentration of sediment in the sample (the number of particles per unit volume) according to the number of "particles" in the sample and the volume of the urine sample passing through the flow cell. The calibrator of a known concentration is measured for the purpose of calibration on the detection system, so as to establish the metrological traceability of the measurement result obtained from that system.

Materials provided

Common component	30 mL	60 mL	125 mL
US-Calibrator	1 bottle	1 bottle	1 bottle
Element	mouse blood		
Instructions for use	1 pc	1 pc	1 pc

Note: this product is batch-specific. For the detailed target value, see the product label of each batch. Calibrators from different batches cannot be used together.

Materials required (but not provided)

Urine analyzer, general laboratory equipment.

Storage and stability

1. Unopened: the validity period is 12 months when stored under 2–8°C and kept away from sunlight. The product can't be stored under frozen conditions.
2. Opened: the validity period is 30 days when stored under 2–8°C and kept away from sunlight. The product can't be stored under frozen conditions.
3. See packaging label for date of manufacture and expiry date.

Applicable instruments

Zybio Urine sediment analyzer (model: U2600, U2601, U2602, U2610, U2611, U2612), and Urinalysis hybrid

system (model: U3600, U3601, U3602)

Assay procedure

Please follow the instructions of this product and the instructions of the applicable instruments.

1. The instrument shall be calibrated based on a monthly interval.
2. Gently invert it several times to homogenize it.
3. During test with urine sediment analyzer/urinalysis hybrid system: set the instrument at calibration status. Pour the calibrator into a dry and clean test tube. Place the test tube on the target position for calibration of the instrument.
4. After the calibration is completed, the instrument will display successful calibration. If the calibration has failed, please check whether the calibrator is expired and whether the instrument works normally.



Performance characteristics

1. Accuracy: after calibration is performed with the US-calibrator, the relative deviation of the measurement result shall not exceed $\pm 15\%$ when the enterprise reference material is measured;
2. Homogeneity:
 - 2.1 Within-bottle homogeneity: $CV_{\text{within-bottle}} \leq 15\%$;
 - 2.2 Between-bottle homogeneity: the between-bottle homogeneity of the counting results shall be good.









Precautions

1. This product is applicable to the calibration of urine sediment analyzer or urinalysis hybrid system. Do not use it for other purposes.
2. Avoid contact with the skin and eyes. If this product is splashed into eyes, rinse it with running warm water for several minutes; seek medical treatment immediately if pain or swelling occurs; in case of contact with skin, rinse with soapy water, and completely rinse off the product with clean water.
3. Please use this product as required by the instructions. The accuracy of the results cannot be guaranteed for purposes other than the prescribed instructions and intended purpose.
4. Routine precautions for laboratory operations must be followed when this product is used.
5. The calibrator disposal and the containers that have been in contact with the calibrator shall follow the relevant waste regulations such as medical waste or industrial waste. All waste shall be treated as a potential infection source.
6. The calibrator that was opened shall be sealed and stored as instructed, and do not use expired product.
7. This product shall be stored as instructed, and kept away from direct sunlight during operation.

Symbol interpretation

Symbol	Title and Description	Symbol	Title and Description
	In vitro diagnostic medical device		Date of manufacture

US-Calibrator

 LOT	Batch code		Use-by date
	Consult instructions for use		Temperature limit
	Keep away from sunlight		Catalogue number
	CE marking of conformity		Manufacturer
	Authorized Representative in the European Community		

References

1. Urinalysis and Collection, Transportation, and Preservation of Urine Specimens; Approved Guideline—Third Edition, from NCCLS Document GP16-A, 2009.
2. Cong Yulong, Ma Junlong, et al. Modern Urinalyical Technology and Clinic Application, China Science and Technology Press, 1998.
3. Cong Yulong, Ma Junlong, et al. Practical Urinalyical Technology and Clinical Application, People's Health Publishing House, first edition, September, 2013.



Zybio Inc.
 Floor 1 to Floor 5, Building 30, No.6 of Taikang Road, Block C of Jianqiao Industrial Park, Dadukou District, 400082 Chongqing, PEOPLE'S REPUBLIC OF CHINA
 Tel: +86 (0)23 68959999
 Fax: +86 (0)23 68699779
 E-mail: info@zybio.com
 Web: www.zybio.com



Lotus NL B.V.
 Koningin Julianaplein 10, 1e Verd, 2595AA, The Hague, Netherlands.

IFU Revision: 02 Release date: 2022-05-20

Wash Solution

Product Name

Wash Solution
Model: D21

Specifications

REF	Specifications
01.09.1F.01.13.11	100 mL/Bottle
01.09.1F.01.13.12	500 mL/Bottle

Intended purpose

The product is used for thoroughly cleaning the fluid path system of the applicable instruments, including the flow cell. It should be used by healthcare professionals and properly trained personnel.

Operating Principle

Through hydrolysis, the sodium hypochlorite forms hypochlorous acid so as to achieve the disinfection and sterilization effect. The hypochlorous acid is further decomposed to form new ecological oxygen [O], so as to kill pathogenic microorganisms.

Main Components

Sodium hypochlorite: 0.01%-0.5%.

Storage and stability

1. Validity period: 12 months if sealed and stored at 4°C-30°C, dry, and kept away from sunlight; 60 days after opening if stored at 4°C-30°C and kept away from sunlight.
2. See the label for the manufacture date and expiry date.

Applicable instruments

Urine chemistry analyzer (model: U1600, U1601, U1602), Urine sediment analyzer (model: U2600, U2601, U2602, U2610, U2611, U2612), and Urinalysis hybrid system (model: U3600, U3601, U3602) manufactured by Zybico Inc. Other models shall be used after verification.

Usage

Wash Solution can be used for cleaning the fluid path of all the applicable instruments before shut down. Moreover, it can be used for cleaning the flow cell of Urine Sediment Analyzer and Urinalysis Hybrid System.

1. Fill the test tube with about 3 mL of wash solution, put it at the first position of the tube rack, and then put the tube rack on the right side of the rack-in module.
2. After confirming the cleaning operation, the test tube rack will be automatically pushed to the sample aspiration position, where the sample probe will aspirate about 2 mL of wash solution.
3. After soaking with the wash solution for about 3 minutes, shut down the instrument when you perform thorough cleaning, or repeat the operation of cleaning when you clean the flow cell.

For more instructions, refer to the operation manual for applicable instruments.













Performance characteristics

pH \geq 9.00 at 25°C.

Warnings and Precautions

1. Instructions for use must be carefully followed. It is for in vitro diagnostic use only.
2. Avoid contact with skin and eyes; In case of eye contact, please rinse with flowing warm water for several minutes. If it is painful or swollen, seek medical care immediately; In case of skin contact, rinse with soapy water and then rinse thoroughly with water.
3. This product does not contain biological components, but contains chemical components, which may have potential risks of hazardous chemicals. Appropriate protective measures shall be taken during sample collection, treatment, storage, and testing.

Symbol interpretation

Symbol	Title and Description	Symbol	Title and Description
	In vitro diagnostic medical device		Batch code
	Consult instructions for use		Use-by date
	CE marking of conformity		Manufacturer
	Authorized Representative in the European Community		Temperature limit
	Catalogue number		Keep away from sunlight
	Date of manufacture		Warning

References

1. Urinalysis and Collection, Transportation, and Preservation of Urine Specimens; Approved Guideline—Third Edition, from NCCLS Document GP16-A, 2009.
2. Cong Yulong, Ma Junlong, et al. Modern Urinalytical Technology and Clinic Application, China Science and Technology Press, 1998.



Zybico Inc.
Floor 1 to Floor 5, Building 30, No.6 of Taikang Road, Block C of Jianqiao Industrial Park, Dadukou District, 400082 Chongqing, PEOPLE'S REPUBLIC OF CHINA
Web: www.zybico.com
E-mail: info@zybico.com
Tel: +86 (0) 6895 9999
Fax: +86 (0) 6869 9779



Lotus NL B.V.
Koningin Julianaplein 10, 1e Verd, 2595AA, The Hague, Netherlands.

Current Revision and Release Date: 03, 2022-11