

OPERATION MANUAL
X-RAY TUBE ASSEMBLY
0.6/1.2P18DE-85
0.6/1.2P38DE-85

Read this operation manual thoroughly before you use the product. Keep this operation manual for future reference.



This medical device also complies with RoHS directive.

Thank you for purchasing a SHIMADZU medical equipment. Before using the equipment, please read this manual thoroughly and use the equipment correctly.

NOTE

The precautions and prohibitions seen through the manual are classified as follows:

DANGER

Indicates an imminently hazardous situation which, if not avoided, will result in serious injury or death.

WARNING

Indicates a potentially hazardous situation which, if not avoided, could result in moderate to serious injury or possibly death.

CAUTION

Indicates a potentially hazardous situation which, if not avoided, may result in minor to moderate injury equipment damage.

NOTE

Emphasizes additional information that is provided to ensure the proper user of this product.

This manual is originally drafted and approved and supplied in English by the manufacturer.

Revision history

Rev.	Description	Date
G	Comply with RoHS. Add Revision history.	2013-12
H	Revise 1.5 , 1.6 , 1.7 and 2.	2015-09
J	Revise 1.1, 1.8.	2018-03
K	Revise 1.6, 1.8.	2018-11
L	Revise 1, 2, 6, 7 and 11.	2020-03-16

Operating Precautions

"Operating Precautions (for both the Safety and the Prevention of Danger) in the Use of Electric Medical Equipment"

1. Nobody without the following experience and knowledge should use the system.
 - (1) Medical (radiographic) training (if particular qualifications are required in the country concerned, those qualifications must be held).
 - (2) The capacity to read and understand the operation manual.
2. When installing the equipment, pay attention to the following items:
 - (1) Do not install system near water faucet or similar equipment.
 - (2) Install it away from potential sources of problems such as abnormal pressure, temperature or humidity, drafts, direct sunlight, dust chlorine or sulfur gas.
 - (3) During transportation and operation of the equipment, avoid tilting, vibration and any impact against it.
 - (4) Keep the equipment away from the areas where chemicals or gases are stored.
 - (5) Use only the correct electrical power source with matching frequency, voltage and current (or wattage).
 - (6) Check the condition of the battery power source (power and polarity) before operating the equipment.
 - (7) Properly ground the equipment
3. Before operating the equipment, pay attention to the following items:
 - (1) Check the conditions of switch contacts, polarity, dial settings, and meters, and make sure the equipment performs correctly.
 - (2) Confirm that the ground is connected properly.
 - (3) Check all wiring for proper and correct connections.
 - (4) Pay attention when using more than one unit at a time, because it may lead to an incorrect diagnosis and cause danger.
 - (5) Check the condition of the external electric circuit, which will be directly connected to a patient.
 - (6) Check the condition of the battery power source.
4. While operating the equipment, pay attention to the following items:
 - (1) Do not over-exceed time or the amount of equipment use needed for diagnosis or therapy.
 - (2) Observe the equipment and patient continuously for early detection of problems.
 - (3) When a problem is detected with the equipment, take proper action to stop the equipment without harming the patient.
 - (4) Do not let the equipment touch the patient.

5. After operating the equipment, pay attention to the following items:
 - (1) Turn off the switches and return the dial to their original before use in the prescribed order. Then, turn off the main power switch.
 - (2) Do not pull the power cable forcibly from the outlet.
 - (3) When storing the equipment, pay attention to the following factors:
 - (i) Keep it away from the water.
 - (ii) Store it away from the potential causes of problems such as abnormal pressure, temperature or humidity, draft, direct sunlight, dust chlorine or sulfur gas.
 - (iii) During transportation and storage of the equipment, avoid tilting, vibration and sharp impact against it.
 - (iv) Store the equipment away from areas where chemicals and gases are stored.
 - (4) Clean all attachments, cables and contacts, and store them in one place.
 - (5) Keep the equipment clean to avoid problems during the next use.
6. When the equipment is found to be out of order, do not try to repair it. Display an appropriate sign to indicate that the equipment is out of order, and call a certified repair technician for repair.
7. Do not modify and part of the equipment.
8. Preventive maintenance
 - (1) The equipment and its parts should be periodically checked.
 - (2) If the equipment has not been in operation for an extended period of time, test it prior to actual operation to make sure it works correctly and safety.
9. Concerning other items, operate properly according to the operating manual.

WARNING

The responsibility for management of use and maintenance of a medical equipment lies in a user.

This device is restricted to use by, or on the order of, a diagnostic radiology technician or a person with a certificate indicating equal proficiency.

Repair and inspection of the inside of the equipment is dangerous. Make sure to contact our service agency for repair and inspection.

To avoid the risk of electric shock, this equipment must only be connected to a supply with protective earth.

NEVER MODIFY THE EQUIPMENT!

In general, almost all of the modifications are strictly prohibited by the Regulatory requirements of the law of the country where device is installed.

Please contact our service agency if it is needed to modify the device.

PERFORM PERIODIC INSPECTION!

Preventive maintenance is required to maintain safety and performance of this system for a long time.

This manual gives detailed description of occasional and periodic maintenance and inspection that a user should perform.

As to the maintenance and inspection that specially trained Specialists exclusively can perform, utilize the maintenance Agreement offered by our company.

WARNING

Do NOT perform any maintenance work of the equipment during study.
The patient may be injured.

Shimadzu Limited Product Warranty

The system is warranted to be free from defects in material and workmanship for one year from the date of delivery. If found to be defective, the system must be offered to Shimadzu for inspection and examination. Upon examination, Shimadzu, at its sole option, will repair or replace at no charge, the system or any part found to be defective. Components which wear are not warranted.

This warranty extends to original purchaser or the lessee of the new system only. If the system is to be resold or delivered to a third party, such third party must be provided with a copy of this manual, the installation manual and the technical manual supplied with the system.

This warranty does not apply to the following:

1. Failure or damage due to any installation, relocation, or service not provided by the SHIMADZU service representative or a SHIMADZU designated contractor.
2. Failure or damage caused by the product of other companies (except those purchased from SHIMADZU).
3. Failure or damage due to repairs using non-SHIMADZU certified service parts.
4. Failure or damage due to non-compliance with the notices and procedures set forth in this manual.
5. Failure or damage due to any operating environment deviating from the requirements set forth in this manual.
6. Failure or damage due to natural disasters such as power surge, rain, fire, earthquake, flood, and thunder.

Service after the expiration of the warranty is available at a reasonable cost and should be performed by the SHIMADZU service representative.

IN NO EVENT SHALL SHIMADZU AND ITS AFFILIATED ENTITIES BE LIABLE TO ANY PERSON OR ENTITY FOR ANY DIRECT, INDIRECT, INCIDENTAL, SPECIAL OR CONSEQUENTIAL DAMAGES (INCLUDING, WITHOUT LIMITATION, ANY DAMAGES RESULTING FROM LOSS OF USE, BUSINESS INTERRUPTION, LOSS OF PROFITS, LOSS OF SAVINGS, THE COST OF PROCUREMENT OF SUBSTITUTED GOODS, SERVICES OR TECHNOLOGIES OR FOR ANY MATTER ARISING OUT OF OR IN CONNECTION WITH THE USE OR INABILITY TO USE THE SYSTEM.

In some jurisdictions, some of the foregoing warranty disclaimers or damage limitations may not apply.

Shimadzu will be indemnified for any claim, liability, or damage arising out of the misuse or non-compliance with this manual by the purchaser or lessee of the system.

CAUTION

Federal law restricts this device to sale by or on the order of physician.
(This caution is the prescription language required by Federal Regulations in U.S.A.)

CAUTION

Contact your Shimadzu service representative for installation and relocation of the equipment.

This page is intentionally left blank.

CONTENTS

PREFACE	1
1. GENERAL DESCRIPTION	2
1.1 INTENDED USE	2
1.2 DETAILS OF COMPONENTS	2
1.3 NOMENCLATURE OF X-RAY TUBE	3
1.4 NOMENCLATURE OF X-RAY TUBE ASSEMBLY	3
1.5 APPEARANCE	4
1.6 LABELS	5
1.6.1 WARNING LABELS	5
1.6.2 OTHER LABELS	6
1.7 SYMBOLS	7
1.8 STATEMENT OF COMPLIANCE [FOR EUROPE]	8
1.9 STATEMENT OF COMPLIANCE WITH STANDARDS	9
2. TECHNICAL DATA	10
2.1 TECHNICAL DATA LIST	10
2.2 HIGH VOLTAGE GENERATOR	12
3. OPERATING PRINCIPLE	12
4. THERMAL UNIT	13
5. OPERATION PROCEDURE	13
5.1 GENERAL OPERATION PROCEDURE	13
5.2 FLUOROSCOPY	13
5.3 RADIOGRAPHY	13
5.3.1 SINGLE RADIOGRAPHY	13
5.3.2 SPOT FILMING	14
5.3.3 HIGH-SPEED SERIAL RADIOGRAPHY	14
6. CAUTIONS FOR USE	15
6.1 CAUTIONS FOR BEGINNING OF USE	15
6.2 GENERAL CAUTIONS	15
6.3 SEASONING	16
6.3.1 INITIAL SEASONING	16
6.3.2 DAILY SEASONING	16
6.4 SAFETY CIRCUIT	17
6.5 MAINTENANCE OF X-RAY TUBE ASSEMBLY	17
6.5.1 APPEARANCE	17
6.5.2 SAFETY CIRCUIT	17
6.5.3 CONNECTION OF CABLES	18
6.5.4 CLEANING	18
6.5.5 LABEL CHECK	18
6.5.6 MANUAL CHECK	18
7. ENVIRONMENTAL CONDITIONS	19
7.1 TRANSPORTATION	19
7.2 ENVIRONMENTAL CONDITIONS	19
7.2.1 TRANSPORTATION AND STORAGE	19
7.2.2 OPERATION	19
7.3 ELECTROMAGNETIC COMPATIBILITY (EMC) INFORMATION	20
8. REMODELING	21
9. WASTE	21

10.TROUBLESHOOTING	22
11. MAINTENANCE PARTS	22
APPENDIX.....	23
HEATING AND COOLING CURVE	23
X-RAY TUBE ASSEMBLY HEATING AND COOLING CURVE.....	23
SINGLE LOAD RATING CHARTS.....	25
HIGH-SPEED SERIAL LOAD RATING TABLE	27
CATHODE EMISSION CHARACTERISTICS.....	29

PREFACE

Thank you very much for your purchase of this X-ray tube assembly 0.6/1.2P18DE&38DE-85.

The characteristics of this X-ray tube assembly are as follows.

- (a) The target disk of this X-ray tube uses Rhenium-Tungsten faced Molybdenum, and its heat content is 140kJ {200kHU}.
- (b) This apparatus is designed for general radiography and gastrointestinal examination

Please be sure to read this operation manual carefully prior to your use of this apparatus to assure its best operating conditions.

WARNING

Do not operate this unit if there is any uncertainty as to the proper functioning of the system. Refer all servicing to qualified service personnel.

1. GENERAL DESCRIPTION

1.1 INTENDED USE

0.6/1.2P18DE-85 and 0.6/1.2P38DE-85 are intended to be used as X-ray tube assembly for medical diagnosis for radiographic and fluoroscopic examinations.

1.2 DETAILS OF COMPONENTS

X-ray tube assembly 0.6/1.2P18DE-85 and 0.6/1.2P38DE-85 are composed as Table1.

And option parts are shown in Table2.

Table 1 Components

Description	Model
X-ray tube assembly	0.6/1.2P18DE-85, 0.6/1.2P38DE-85
Packing	Packing #1
Accompanying document	-

Table 2 Option Parts

Description	Model
Supporter Ring	Ring B-80
Fan	Fan #3
Low voltage cable	Low voltage cable #21

1.3 NOMENCLATURE OF X-RAY TUBE

Nomenclature of X-ray tube is as follows.

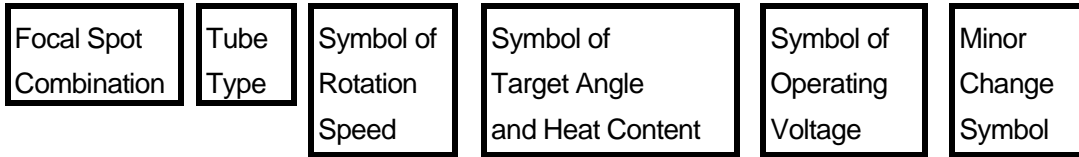

In case of 0.6/1.2P38DE

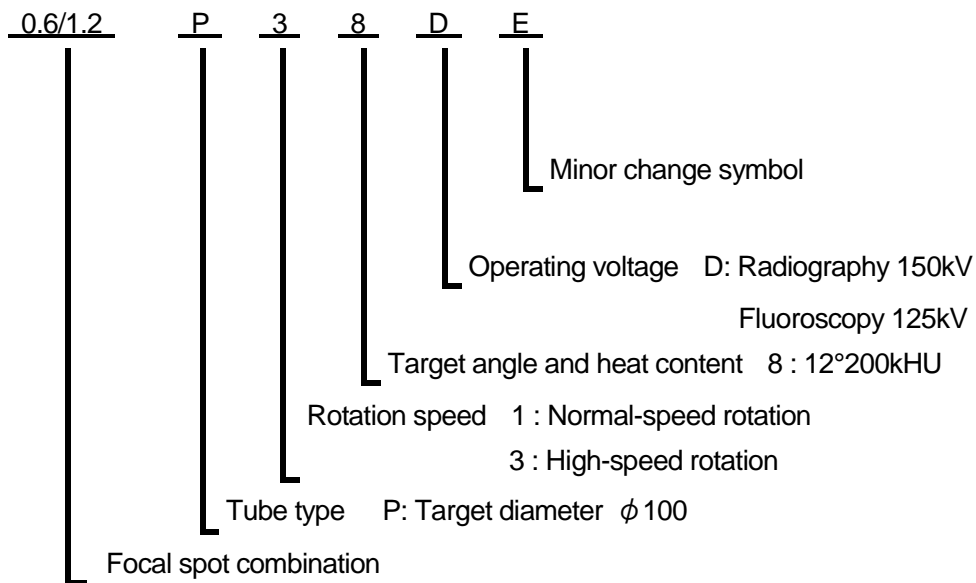

1.4 NOMENCLATURE OF X-RAY TUBE ASSEMBLY

Nomenclature of X-ray tube assembly is as follows.

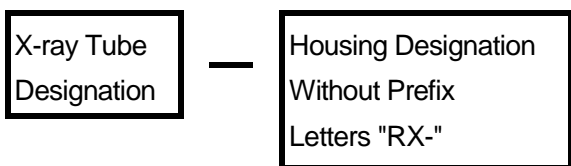

In case of 0.6/1.2P18DE-85

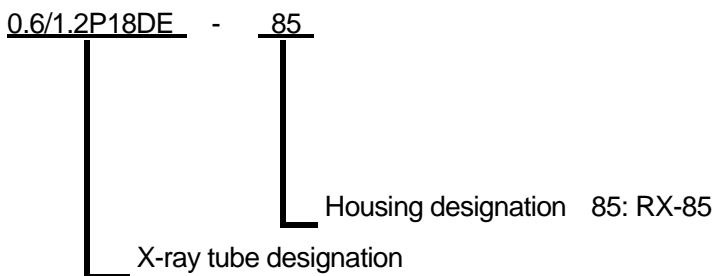

1.5 APPEARANCE

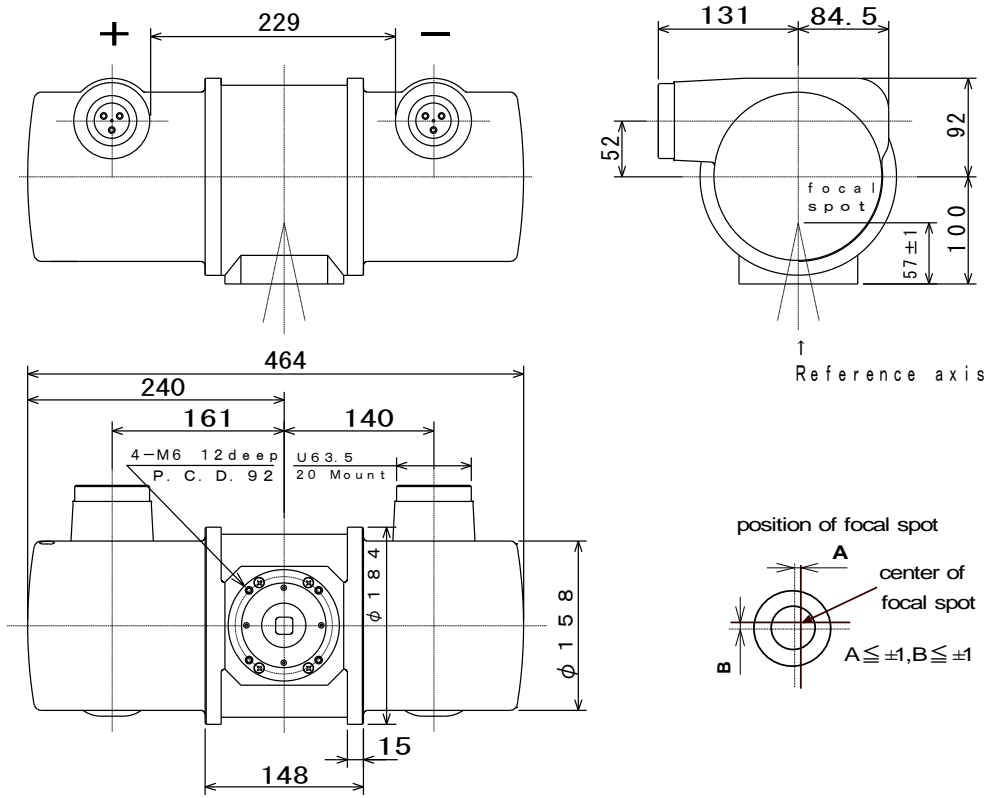

UNIT : mm

Fig.1 X-ray Tube Assembly

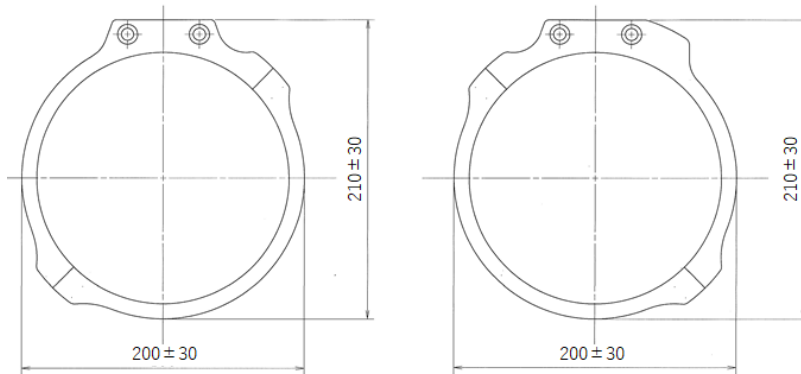

UNIT : mm

Fig.2 Supporter Ring

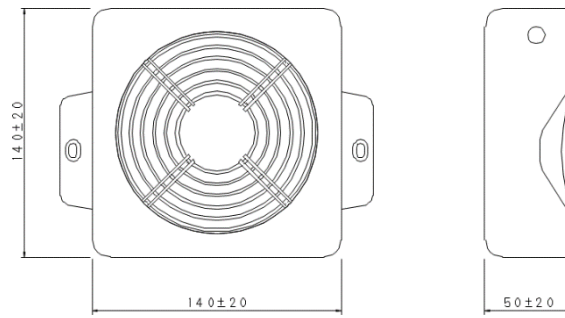

UNIT : mm

Fig.3 Fan

1.6 LABELS

Fig. 4 LABELS ON X-RAY TUBE ASSEMBLY

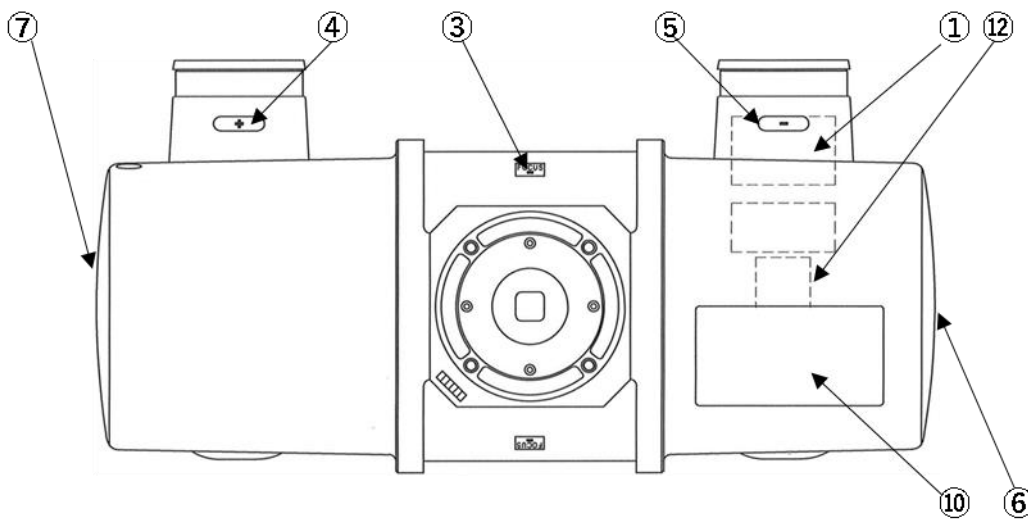

1.6.1 WARNING LABELS

① Warning Label (High voltage)

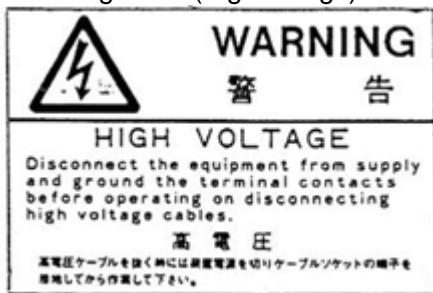

1.6.2 OTHER LABELS

⑥ Identification Label (X-ray tube assembly)

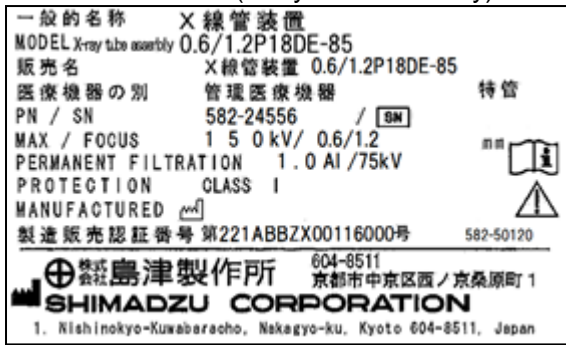

③ Focus Label

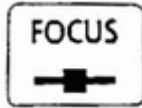

④⑤ Polarity of high voltage label

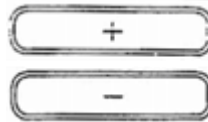

⑫ Follow manual label



⑦ Caution Label (for RX-125 type only, adjust the starter setting)

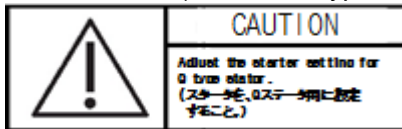



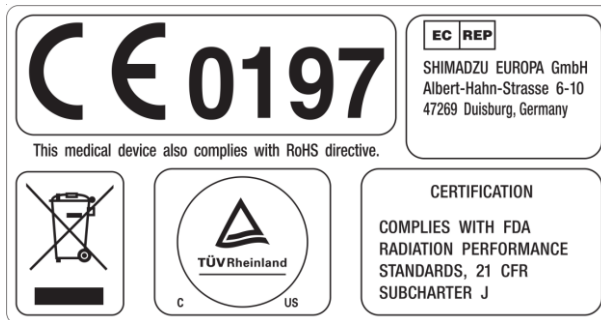









⑩ CE UL WEEE Label



1.7 SYMBOLS

The symbols used on the X-ray tube assembly are shown below:

Symbol	Location	Meaning
	On Identification label	Refer to the operation manual
	On warning label	Observe described items, or refer to the operation manual
	On caution label	Refer to the operation manual
	On Identification label	Refer to the operation manual
	On Identification label	Year and month of manufacture
	On Identification label	Manufacturer
	On Identification label	Serial number
	On warning label (High voltage)	Warning: High voltage
	On Follow manual label	Follow the manual
	On packaging	Temperature limitation
	On packaging	No wet
	On packaging	Fragile-Handle with care
	On packaging	Do not turn over

1.8 STATEMENT OF COMPLIANCE [FOR EUROPE]

(a) Regulatory Information for Europe:

The product complies with the requirement of the Medical Device Directive 93/42/EEC and RoHS Directive 2011/65/EU

Product Name : X-ray tube assembly
Model Name : 0.6/1.2P38DE-85
Parts Number : 582-24558
Model Name : 0.6/1.2P18DE-85
Parts Number : 582-24556
Manufacturer : SHIMADZU CORPORATION Medical Systems Division
Address : 1, NISHINOKYO-KUWABARACHO,
NAKAGYO-KU, KYOTO, 604-8511, JAPAN
Authorized Representative / Importer : Shimadzu Europa GmbH
Address : Albert-Hahn-Strasse 6-10,
47269 Duisburg, Germany

NOTE

When any serious incident occurred in relation to the system, report that to your Shimadzu service representative and to the competent authority of the Member State in you are established.

“Serious incident” means any incident that directly or indirectly led, might have led or might lead to any of the following:

- (a) the death of a patient, user or other person,
- (b) the temporary or permanent serious deterioration of a patient's, user's or other person's state of health,
- (c) a serious public health threat;

(b) Company's Quality System

The company's quality management system complies with the requirements of Annex II, excluding Section 4 of the MDD 93/42/EEC, which is certified by TUV Rheinland LGA Products GmbH (Notified under No.0197)

(c) International Standards

- IEC 60601-1:2005+A1:2012 / EN 60601-1:2006+A1:2013
- IEC 60601-1-3:2008+A1:2013 / EN 60601-1-3:2008+A11:2016
- IEC 60601-2-28:2017 / EN 60601-2-28:2010
- IEC 60522:1999 / EN 60522:1999
- ISO 14971:2007, Corrected version 2007-10-01 / EN ISO 14971:2012
- ISO 15223-1:2016 Corrected version 2017-03 / EN ISO 15223-1:2016
- EN 1041:2008

(d) Protection against radiation

Refer to the standard about the acceptance and performance testing.

(ex:DIN 6868-150:2013-06)

1.9 STATEMENT OF COMPLIANCE WITH STANDARDS

- X-RAY TUBE ASSEMBLY 0.6/1.2P18DE-85), IEC 60601-2-28:2017
- X-RAY TUBE ASSEMBLY 0.6/1.2P18DE-85), EN 60601-2-28:2010
- X-RAY TUBE ASSEMBLY 0.6/1.2P38DE-85), IEC 60601-2-28:2017
- X-RAY TUBE ASSEMBLY 0.6/1.2P38DE-85), EN 60601-2-28:2010

2. TECHNICAL DATA

2.1 TECHNICAL DATA LIST

Table 3. TECHNICAL DATA

Items		Rated value	
Nominal X-ray tube Voltage	Fluoroscopy Radiography	125 kV 150 kV	
X-ray tube assembly	Max. heat content	1100kJ {1600kHU}	
	Nominal continuous input power IEC 60613:2010	470W{660HU/s} : with fan 235W{330HU/s} : without fan	
X-ray tube	Max. anode heat content	140kJ { 200kHU}	
	Max. anode heat dissipation rate	640W {900HU/s}	
	Max. continuous heat dissipation rate	210W { 300HU/s}	
	Continuous anode input power IEC 60613:2010	100W (Repetition of radiographic exposure)	
Nominal focal spot value	IEC 60336	0.6	1.2
Measuring method of focal spot size		Slit camera	Slit camera
X-ray tube max. Fluoroscopic load(10min.)	Anode stationary	355W {500HU/s}	425W{600HU/s}
	Anode rotating	425W {600HU/s}	425W{600HU/s}
Nominal anode input power (0.1sec)	50Hz (18DE)	18kW	48kW
	60Hz (18DE)	21kW	53kW
	180Hz (38DE)	37kW	85kW
Nominal radiographic anode input power IEC 60613:2010	50Hz (18DE)	18kW	48kW
	60Hz (18DE)	21kW	53kW
	180Hz (38DE)	37kW	85kW
Max. filament voltage		12.5 V	18.4 V
Max. filament current *1		5.6 A	5.6 A
Anode target	material	Rhenium-tungsten faced molybdenum	
	angle/diameter	12°/100mm	
Anode rotation *2		Direction of anode rotation is counter-clockwise as viewed from the cathode side, and R.P.M as follows. 2700 min. ⁻¹ {R.P.M.} at 50 Hz 3200 min. ⁻¹ {R.P.M.} at 60 Hz 9700 min. ⁻¹ {R.P.M.} at 180 Hz	
Minimum total filtration IEC 60601-2-28:2017		1.7 mm Al/75 kV (Including added filter*3)	
Permanent filtration*4	IEC 60601-2-28:2017	1.0 mm Al/75 kV IEC 60522:1999 (without added filter)	
	JIS Z 4751-2-28:2008 (IEC 60601-2-28:1993)	Min. 1.5 mm Al at 70kV*5 (Including added filter)	
Leakage radiation *7	IEC 60601-1-3:2008+A1:2013	Leakage radiation in hour from the X-ray tube assembly and collimator is less than 0.87mGy at a distance of 1 meter from the focal spot. However, leakage radiation in an hour from the collimator is less than 0.30mGy.	
X-ray radiation field		350mm × 350mm (at distance of 1000mm from focal spot)	
IEC classification IEC 60601-1:2005+A1:2012		CLASS I	
Mode of operation		Continuous operation with intermittent loading	
Mass *7		21 kg	
High voltage connector		IEC 60526 type	

- *1 This value is the maximum value usable in tube current adjustment, and its limit in usual use is less than 5.2A for both 0.6mm focus and 1.2mm focus.
- *2 The recommended frequency of input power to the stator is less than once a minute.
- *3 Added filter
 Added filter (3 pieces of 0.3mm Al filter, Min. 0.7mmAl equivalent considering the tolerance of thickness) is inserted in X-ray port. It should not be removed in any case to attain specified total filtration.
- *4 Inherent filtration of X-ray tube is min. 0.7 mm Al.
- *5 This value is including the added filter. Total filtration is stated as permanent filtration according to JIS Z 4751-2-28:2008 which is the IDT standard to IEC 60601-2-28:1993.
- *6 Leakage radiation dose measuring condition
- (1) 125kV, 425W continuous
 Actual leakage radiation dose measuring condition: 125kV 125W continuous
 Maximum leakage radiation dose measuring condition: 125kV 425W continuous
 Maximum leakage radiation value is calculated as follows.
 (Maximum leakage radiation value)
 $= (425W/125W) \times (\text{Measured leakage radiation on actual condition})$
 $= 3.4 \times (\text{Measured leakage radiation on actual condition})$
- (2) Repetition of radiographic load so as to become average load of 100W at 150kV
 Actual measuring condition: 150kV 100mA 0.1sec 5times
 Maximum measuring condition: 150kV 100mA 0.1sec 240times/hour (100W)
 Maximum leakage radiation value is calculated as follows.
 (Maximum leakage radiation value)
 $= (240times/5times) \times (\text{Measured leakage radiation on actual condition})$
 $= 48 \times (\text{Measured leakage radiation on actual condition})$
- (3) Unit
 $0.87mGy = 2.58 \times 10^{-5}C/kg = 100mR$
- *7 Mass of option parts
 Support ring: 1.2kg, Fan: 0.5kg

2.2 HIGH VOLTAGE GENERATOR

This apparatus is recommended to be used in combination with Shimadzu's high voltage generator UD150B-10, UD150B-30, UD150B/V/L-40 and ZUD-P/L/V/B40.

NOTE

This apparatus shall be used in combination with Shimadzu's starter SA-41, SA-42, SA-50 or SA-60.

3. OPERATING PRINCIPLE

Operating principle is as follows.

- (1) The filament is heated by passing an electric current, and then thermoelectrons are emitted.
- (2) The anode is rotated by electromagnetic induction from a series of stator.
- (3) A high voltage is applied between the cathode and anode to accelerate the electrons.
- (4) The accelerated electrons strike the anode target and X-rays are generated.
- (5) The field size of X-ray beams are limited by the collimator.
- (6) The heat generated with X-rays is cooled by natural heat dissipation or cooled forcibly by the fan.

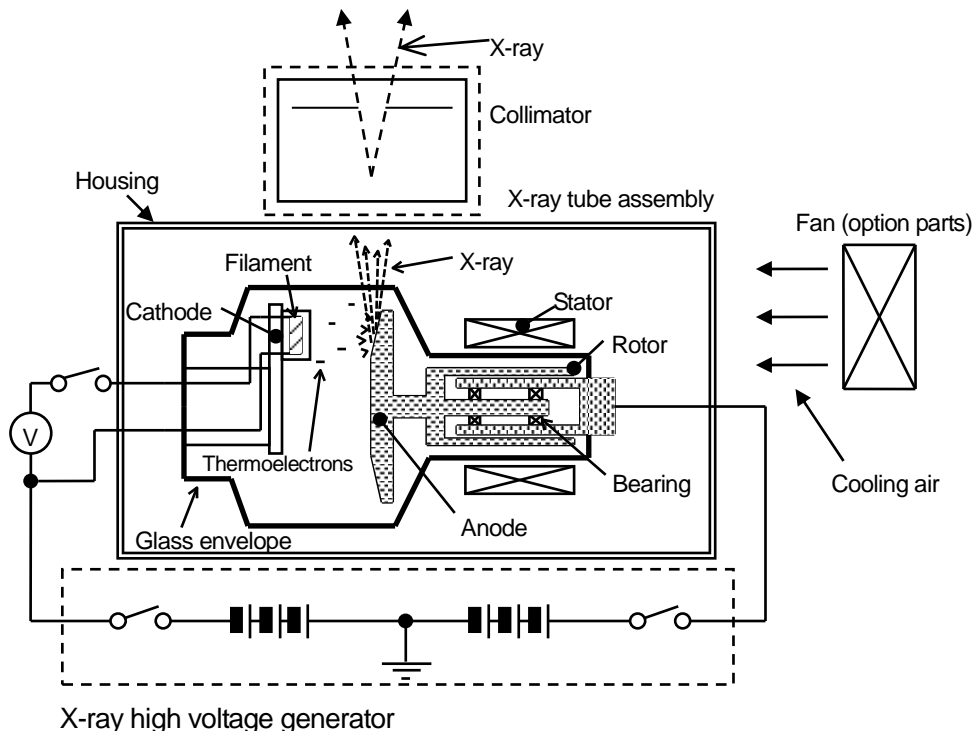

Fig.5 OPERATING PRINCEPLE

4. THERMAL UNIT

Generated heat quantity in the anode of X-ray tube on loading is proportional to the product of tube voltage {kV}, tube current {mA} and loading time {s}. When used in constant voltage, the relationship is as follows. $J = kV \times mA \times s$ {HU = kV × mA × s × 1.41}, $W = kV \times mA$ {HU/s = kV × mA × 1.41}

Remarks: 1J = 1.41HU = 0.24cal {1HU = 0.71J = 0.17cal}, 1W = 1J/s = 1.41HU/s

5. OPERATION PROCEDURE

5.1 GENERAL OPERATION PROCEDURE

General operation procedure is as follows.

- (1) Turn on the X-ray diagnostic apparatus.
- (2) Carry out the daily seasoning described in subsection 6.3.2.
- (3) Prepare to diagnose a patient.
- (4) Fluoroscope the patient.
- (5) Limit the field size of X-ray beam by operating the collimator.
- (6) Operate ready switch for the X-ray tube to get ready ,and conduct radiography after “READY” sign is shown.
- (7) After operating ,keep running the cooling fan about 20 minutes for cooling down the X-ray tube, and then turn off the X-ray diagnostic apparatus.

5.2 FLUOROSCOPY

Use the 0.6/1.2P18DE&38DE at the load of less than the condition (X-ray tube maximum fluoroscopic load [≤ 10 min.] and X-ray maximum continuous heat dissipation rate [> 10 min.]) set forth in Table 3.

5.3 RADIOGRAPHY

Refer to SINGLE LOAD RATING CHARTS. Rating Charts support to indicate the absolute maximum load of X-ray tube in a short time and are showing the relation between the X-ray tube current (in mA) and the loading time (in sec) for various voltages (in kV). SINGLE LOAD RATING CHARTS is supposed to show the maximum permissible value. Never apply the load over ratings at any condition of operation including permissible error of the apparatus. So, it is recommendable to operate the tube under the condition of less than 90% of SINGLE LOAD RATING CHARTS.

5.3.1 SINGLE RADIOGRAPHY

- (a) The load of exposure must be less than 90% of SINGLE LOAD RATING CHARTS.
- (b) Take the rest time so that the average anode load will become 71W {100HU/s}. The necessary rest time should be 10 minutes if the value obtained in the above expression exceeds 10 minutes.

5.3.2 SPOT FILMING

Radiography including fluoroscopy on gastro-intestinal examination.

- (a) The average load of fluoroscopy and radiography should be less than 210W{300HU/s}.
- (b) The radiographic load should be less than 80% of SINGLE LOAD RATING CHARTS, if the average load is less than 177W{250HU/s}, and less than 70% if exceeding 177W{250HU/s}. By the way, the exposure interval may be optional.
- (c) The average load of X-ray tube assembly(fluoroscopy+radiography+stator load) is less than 330W{460HU/s}.

5.3.3 HIGH-SPEED SERIAL RADIOGRAPHY

- (a) The X-ray tube should be rested for more than 10 minutes before performing High-Speed serial radiography.
- (b) Find allowable load as following procedure. Referring to HIGH-SPEED SERIAL LOAD RATING TABLE, find a block under "Number of exposures in series" which is greater than or equal to expected number of exposures in series. Select a block under "Tube load (kW) as a function of the exposure time (sec.) of the individual radiographs of the series" which is greater than or equal to expected exposure time. At the intersection of the two blocks, find maximum kW allowed for each exposure.
- (c) Example

Now, determine kW allowed with following factors for '1.2' focal spot of 0.6/1.2P38DE.

Maximum number of exposures : 40

Exposure time: 0.05 second

From the HIGH-SPEED SERIAL LOAD RATING TABLE, find 40 exposure block and 0.05 second block. At the intersection of the two blocks, find 22.2kW allowed for each exposure.

- (D) Take rest time so that the average anode load becomes 210W, in case that X-ray tube is operated for more than 20 minutes.

- In case of high voltage generator being micro computer type, such as Shimadzu UD150B-40 or UD150-B30, type allowable load and number of series are controlled automatically. In case of high voltage generator being non-micro computer type, determine load factor with referring this chapter.

6. CAUTIONS FOR USE

6.1 CAUTIONS FOR BEGINNING OF USE

Handling the X-ray tube assembly without qualification is prohibited by law, and do not execute installation and adjustment without our serviceman or designated serviceman.

WARNING

Be careful of exposure to X-ray
Take measures for protection from X-ray

- (a) To use this X-ray tube assembly for many years, it is recommended to take as much rest time between patients as possible.
- (b) In the event of an abnormally high sound of rotation, discharge or such a situation that a high voltage can not be loaded, please contact your nearest service organ immediately.

6.2 GENERAL CAUTIONS

- (a) Do not use this apparatus in an atmosphere of inflammable or noxious gas.
- (b) The X-ray tube assembly is high voltage proof but be sure to use ethanol anhydride for the disinfection.
- (c) To reduce the unnecessary evaporation of filament and make the life of the X-ray tube be longer, it is recommended to shorten the time between ready up and exposure.
- (d) Don't turn off the power switch for at least 20 minutes after operating the X-ray tube assembly to cool it by the fan.

CAUTION

Take appropriate measures such as preparing alternative apparatus to prevent a patient from being in danger if tube is broken.

Because the X-ray tube could break down suddenly due to its product lifetime or unexpected failure.

6.3 SEASONING

6.3.1 INITIAL SEASONING

When using the X-ray tube assembly for first time after its installation or when resuming its use after suspension of use for longer than one month, the following seasoning must be taken.

- (a) With the X-ray tube current kept at 1mA, raise the X-ray tube voltage gradually from 50kV to the Nominal X-ray tube voltage(125kV) at the rate of 10kV/min, and energize the X-ray tube assembly for 5 min. with this voltage.
- (b) Take the rest time for 5 min.
- (c) Raise the X-ray tube voltage with a large focus spot as follows, and apply the following load at the rate of once in one minute per each voltage.
 - ① 80kV,0.1sec. ·····1 time
 - ② 90kV,0.1sec. ·····1 time
 - ③ 100kV,0.1sec. ·····1 time
 - ④ 110kV,0.1sec. ·····2 times
 - ⑤ 120kV,0.1sec. ·····2 times
 - ⑥ 130kV,0.1sec. ·····2 times
 - ⑦ 135kV,0.1sec. ·····2 times
 - ⑧ 140kV,0.1sec. ·····2 times
 - ⑨ 145kV,0.1sec. ·····2 times
 - ⑩ 150kV,0.1sec. ·····2 times
- (d) When there is such abnormality as unstable tube current during the aforementioned seasoning, lower the tube voltage to where it becomes stable, energize the tube assembly at that point for a while, and then raise the tube voltage again.

* The X-ray tube current must be selected the value that is determined by a half of maximum mA position at each X-ray tube voltage.

6.3.2 DAILY SEASONING

Before using the X-ray tube assembly, the following seasoning must be taken everyday.

- (a) With the X-ray tube current kept at 1mA, raise the X-ray tube voltage gradually from 50kV to the Nominal X-ray tube voltage (125kV) at the rate of 10kV/min, and energize the X-ray tube assembly for 5 min. with this voltage.
- (b) Take the rest time for 5 min.
- (c) Raise the X-ray tube voltage with a large focal spot as follows, and apply the following load at the rate of once in one minute per each voltage.

- ① 90kV,0.1sec. ·····1 time
- ② 100kV,0.1sec. ·····1 time
- ③ 110kV,0.1sec. ·····1 time
- ④ 120kV,0.1sec. ·····1 time

*The X-ray tube current must be selected the value that is determined by a half of maximum mA position at each X-ray tube voltage.

If the X-ray tube assembly is used at the range near Nominal X-ray tube voltage, proceed to take the following seasoning.

- ⑤ 130kV,0.1sec. ·····1 time
- ⑥ 140kV,0.1sec. ·····1 time
- ⑦ 145kV,0.1sec. ·····1 time
- ⑧ 150kV,0.1sec. ·····1 time

*The X-ray tube current must be selected the value that is determined by a half of maximum mA position at each X-ray tube voltage.

(d) When there is such abnormality as unstable tube current during the aforementioned seasoning, lower the tube voltage to where it becomes stable, energize the tube assembly at that point for a while, and then raise the tube voltage again.

(e)

6.4 SAFETY CIRCUIT

The thermal switch actuates to stop impressing the high voltage when the temperature inside the tube housing reaches 80 °C.

6.5 MAINTENANCE OF X-RAY TUBE ASSEMBLY

Periodical check of the X-ray tube assembly is necessary to maintain its stable performance and life for many years. The maintenance items and frequency are shown in the following Table 4 and 5. Also, in the following section, the detail of maintenance items and the others is shown.

Table 4 THE INSPECTION ITEMS FOR MAINTENANCE BY AN OPERATOR

Item	Frequency	Detail (Section No.)
Appearance	Before daily use	6.5.1
Safety circuit		-
Seasoning		6.3.2

Table 5 THE INSPECTION ITEMS FOR MAINTENANCE BY A MANUFACTURER

Item	Frequency	Detail (Section No.)
Appearance	Within a year	6.5.1
Safety circuit		6.5.2
Connection of high voltage cables		6.5.3
stator coils		Refer to Installation manual
Rotation of anode		10. TROUBLE SHOOTING

6.5.1 APPEARANCE

Check no oil leakage from the X-ray tube housing.

6.5.2 SAFETY CIRCUIT

Check function of this circuit, continuity of ground terminal wire, etc. Should there be the case where the thermal switch actuates, contact us or our agent because such a happening is abnormal.

6.5.3 CONNECTION OF CABLES

Replace the isolation packing with new one every year. Be sure to replace it whenever H.V. cable is disconnected from H.V. socket for repair or maintenance purpose.

Replacement shall be done by our service person. For connecting and disconnecting, please refer to installation manual.

6.5.4 CLEANING

Wipe the surface of the equipment with a cloth moistened with rubbing alcohol. (intermediate level disinfectant) If rubbing alcohol gets inside the equipment, it can cause failure or accidents.

6.5.5 LABEL CHECK

Please check labels identified in section 1.5 and 1.6. If these labels are degraded or missing, please contact our service office or representative described on the back cover of the operation manual.

6.5.6 MANUAL CHECK

If any page of the manual is missing, please contact our service office or representative described on the back cover of the operation manual.

7. ENVIRONMENTAL CONDITIONS

7.1 TRANSPORTATION

In transportation of the X-ray tube assembly, be careful to handle it not to give excessive shock (vibration).

7.2 ENVIRONMENTAL CONDITIONS

7.2.1 TRANSPORTATION AND STORAGE

Transportation and storage environmental conditions are as follows.

X-ray tube assembly shall be transported and stored in the packing box.

Ambient temp. : -20 - 70 °C

Relative humidity : 10 - 95 % (No condensation)

Atmospheric pressure: 500 - 1,060 hPa {50 - 106kPa}

7.2.2 OPERATION

Operation environmental conditions are as follows.

Ambient temp. : 5 - 40 °C

Relative humidity : 30 - 90 % (No condensation)

Atmospheric pressure: 700 - 1,060 hPa {70 - 106kPa}

7.3 ELECTROMAGNETIC COMPATIBILITY (EMC) INFORMATION

WARNING

This equipment needs special precautions regarding EMC.

Install and use the equipment according to the EMC information provided in the operation manual for the X-ray system.

WARNING

Make sure that electromagnetic compatibility is obtained.

All peripheral devices for the X-ray system must satisfy EMC standards regarding emission of electromagnetic energy and susceptibility to electromagnetic environment.

Devices that do not satisfy these standards may disturb the correct functioning of the equipment. In the worst case, this can cause serious injuries or clinical errors.

WARNING

Do NOT use this equipment adjacent to, or stacked with, other equipment.

If adjacent or stacked use is necessary, check to be sure that this equipment works properly in the environment.

WARNING

Do not use accessories, transducers and cables other than those specified or provided by Shimadzu.

The use of accessories, transducers and cables other than those specified or provided by Shimadzu could result in increased electromagnetic emissions or decreased electromagnetic immunity of this equipment and result in improper operation.

WARNING

Portable RF communications equipment (including peripherals such as antenna cables and external antennas) should be used no closer than 30 cm to any part of the equipment.

Otherwise, degradation of the performance of this equipment could result.

8. REMODELING

Remodeling of the apparatus shall be subject to agreement with our Engineering Section with actual remodeling done by our serviceman or those of a company so designed by us. Do not remodel the apparatus without our agreement.

9. WASTE

On wasting X-ray tube assembly, contact our service department because it may be harmful to environment if the contents of X-ray tube assembly should come out.

Action for Environment

To all user of Shimadzu equipment in the European Union:

Equipment marked with this symbol indicates that it was sold on or after 13th August 2005, which means it should not be disposed of with general household waste. Note that our equipment is for industrial/professional use only.

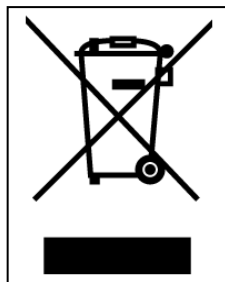

Fig.6 WEEE Mark

**Contact Shimadzu service representative when the equipment has reached the end of its life.
They will advise you regarding the equipment take-back.**

With your co-operation we are aiming to reduce contamination from waste electronic and electrical equipment and preserve natural resource through re-use and recycling.

Do not hesitate to ask Shimadzu service representative, if you require further information.

10. TROUBLESHOOTING

If a trouble occurs, contact your nearest service organ without disassembling the tube assembly.

- (a) In the following cases of anode rotation, you may continue using the X-ray tube.
- ① Rotating sound is high, but it is continuous sound and there is no abnormal sound like creak or scratch sound during rotation.
 - ② Inertial rotation of the X-ray tube continues over 2 minutes after loading, and rotation does not stop quickly. (Check for this by 50/60Hz driving)
- (b) There might be a case of a small flaw or stain-like trace on the target of the X-ray tube, but this is due to small discharge occurring in the course of seasoning. As far as steady operation is conducted at Nominal X-ray tube voltage attained at the end of seasoning described in Subsection 6.3.1 and 6.3.2, there is no hindrance to electrical performance.

11. MAINTENANCE PARTS

Our company service representative will exchange the maintenance parts of this product.

Refer to the Table 11 for a list of the maintenance parts.

Table 6 LIST OF MAINTENANCE PARTS

Parts name	Parts number	Necessary amount
Low voltage cable, #21	582-24777	1
Fan, F-3	582-22332	1
Isolation packing(alternative) Packing, #1 Silicone packing (3 mm)	582-23029 571-15191-88	2

APPENDIX

Heating and Cooling Curve X-ray tube anode

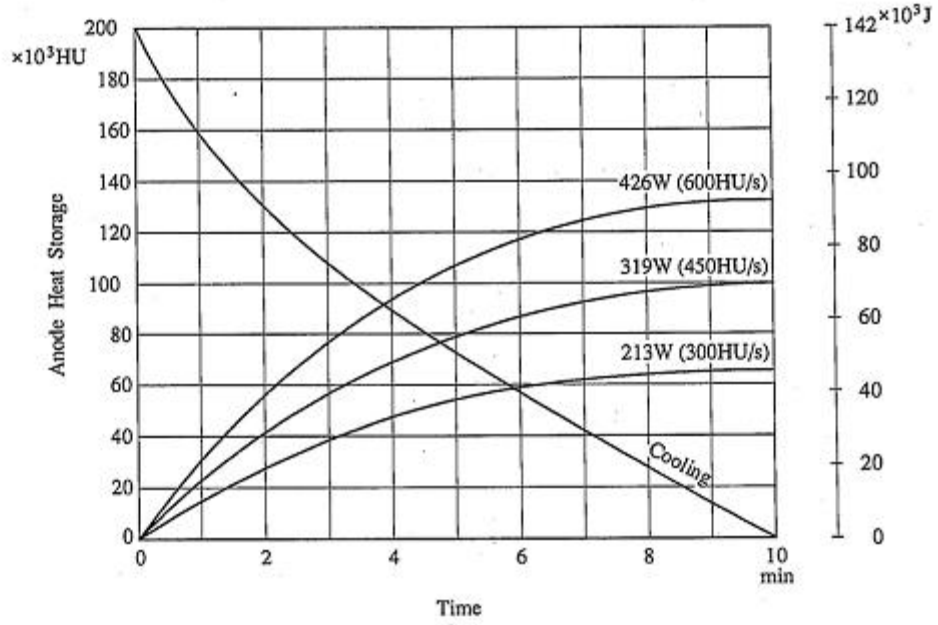

X-RAY TUBE ASSEMBLY HEATING AND COOLING CURVE (with fan)

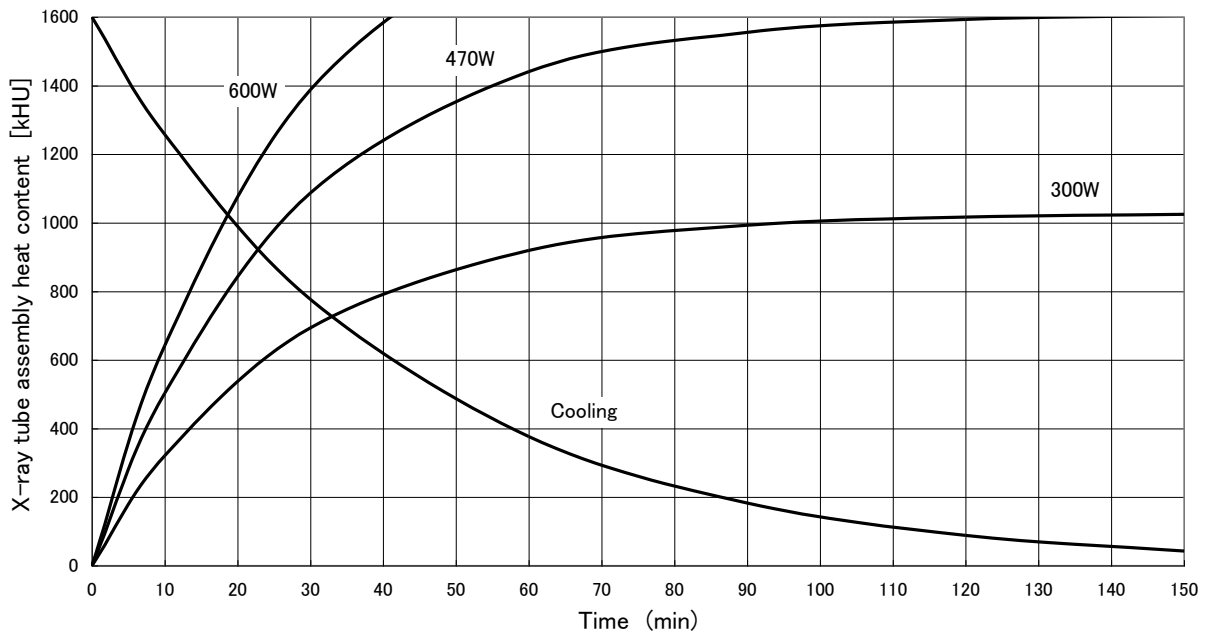

X-RAY TUBE ASSEMBLY HEATING AND COOLING CURVE (without fan)

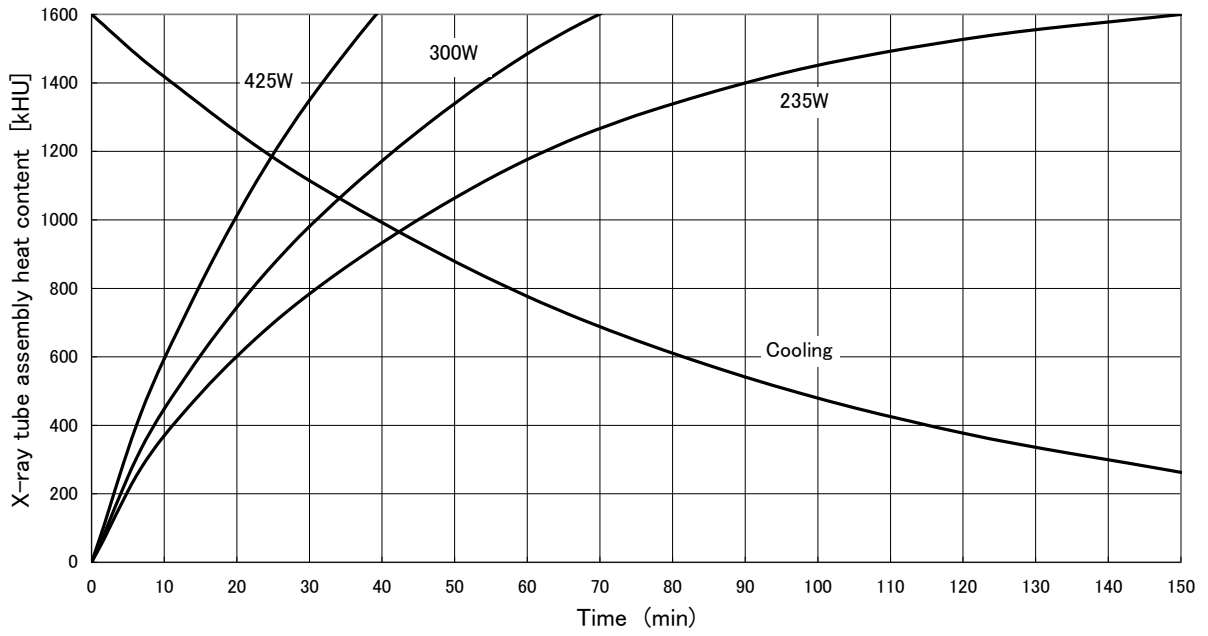

SINGLE LOAD RATING CHARTS

Maximum Rating Charts

Three-Phase Full Wave Rectification

"0.6" P18DE & P38DE

50Hz three phase or constant voltage

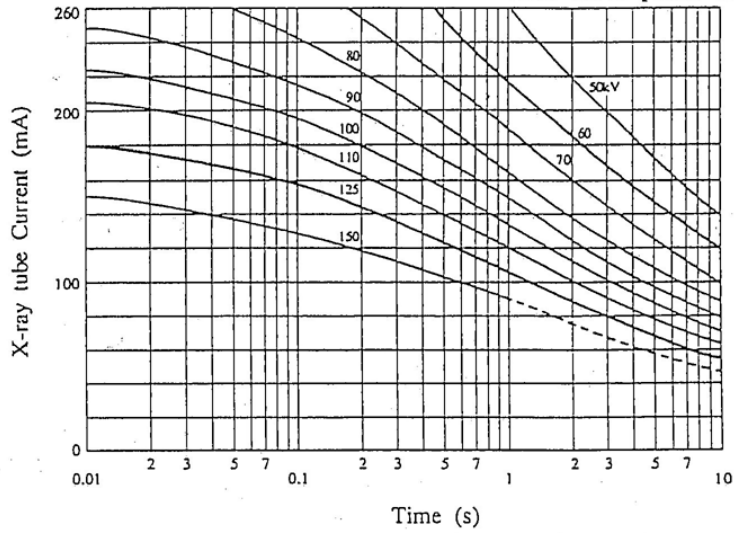

60Hz three phase or constant voltage

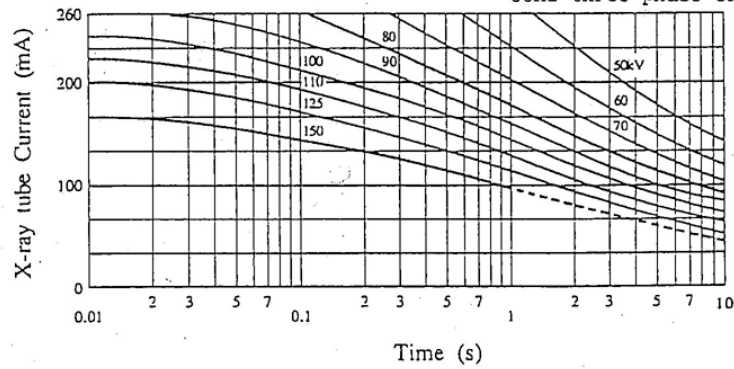

180Hz three phase or constant voltage

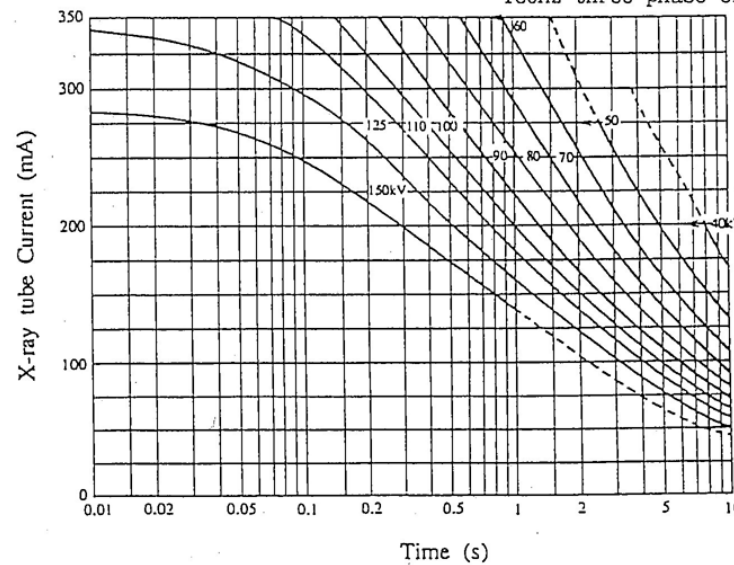

Refer to IEC 60613:2010

Maximum Rating Charts

Three-Phase Full Wave Rectification

"1.2" P18DE & P38DE

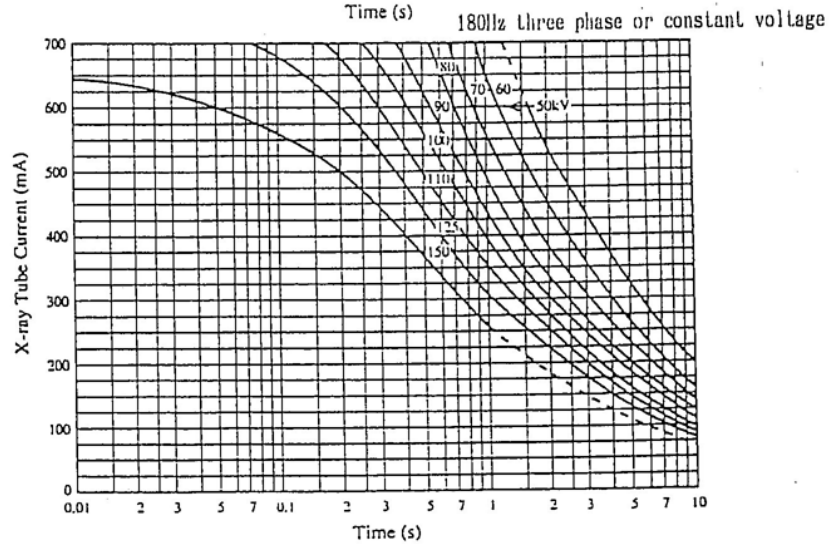
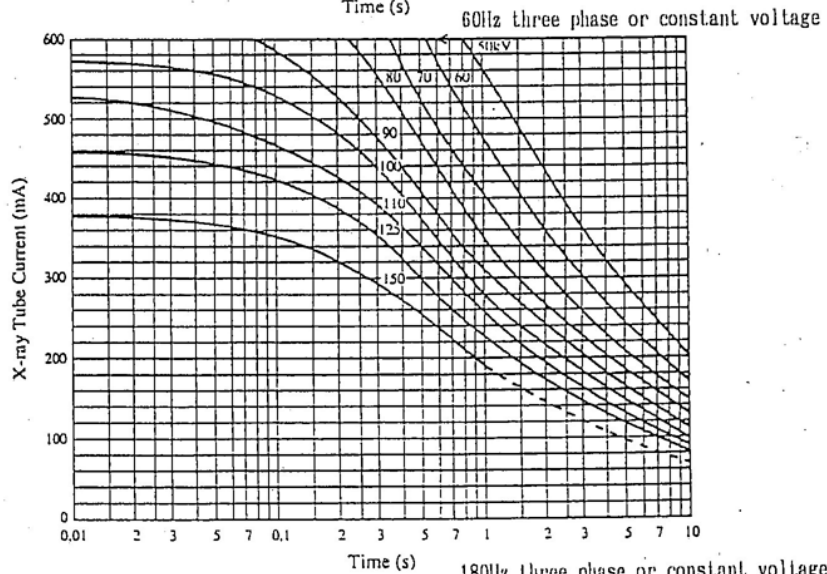
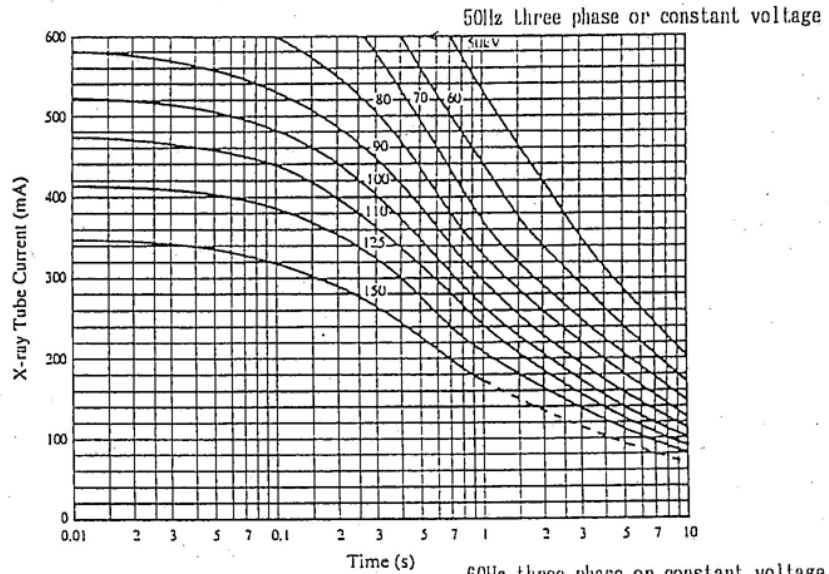

Refer to IEC 60613:2010

HIGH-SPEED SERIAL LOAD RATING TABLE

”0.6”P18DE, 50Hz, Three Phase or Constant voltage

Number of exposure in series (exp)	Tube load (kW) as a function of the exposure time (seconds) of the individual radiographs of the series														
	0.01	0.02	0.03	0.04	0.05	0.06	0.08	0.1	0.12	0.14	0.16	0.18	0.2	0.225	0.25
10	15.2	13.8	12.7	12.1	11.7	11.3	10.8	10.3	10.0	9.5	9.2	8.8	8.4	8.2	7.9
20	13.8	12.1	11.3	10.8	10.3	10.0	9.2	8.4	8.0	7.5	7.2	7.1	6.8	6.5	6.3
40	12.1	10.8	10.0	9.2	8.4	8.0	7.2	6.8	6.5	6.4	6.2	5.8	5.5	5.3	5.1
60	11.3	10.0	8.8	8.0	7.3	7.1	6.5	5.9	5.8	5.5	5.2	5.0	4.8	4.5	4.2
80	10.8	9.2	8.0	7.2	6.8	6.5	6.2	5.5	5.2	4.9	4.5	4.5	4.3	3.9	3.6
100	10.3	8.4	7.3	6.8	6.3	5.9	5.5	5.1	4.8	4.5	4.3	3.9	3.6	2.8	2.4
150	9.3	7.3	6.5	5.9	5.6	5.3	4.8	4.2	3.9	3.3	2.6	2.2	1.8	1.7	1.6

”1.2”P18DE, 50Hz, Three Phase or Constant voltage

Number of exposure in series (exp)	Tube load (kW) as a function of the exposure time (seconds) of the individual radiographs of the series														
	0.01	0.02	0.03	0.04	0.05	0.06	0.08	0.1	0.12	0.14	0.16	0.18	0.2	0.225	0.25
10	38.4	35.3	32.4	30	27.6	26.2	24	21	19.2	17.7	16.8	16.4	15.7	15.1	14.7
20	35.3	30	26.2	24	21	19.2	16.8	15.7	14.6	14	13.5	13.1	12.9	12.4	12
40	30	24	19.2	16.8	15.7	14.6	13.5	12.9	12.2	11.4	10.7	10	9.4	8.6	7.8
60	26.2	19.2	16.4	14.6	13.8	13.1	12.2	11.2	10	9	8.4	7.3	6.8	6.3	5.8
80	24	16.8	14.6	13.5	12.9	12.2	10.7	9.4	8.4	7.3	6.5	6	5.6	5.2	4.8
100	21	15.7	13.8	12.9	12	11.2	9.4	7.8	6.8	4.5	5.6	5.2	4.8	4.2	3.6
150	17.2	13.8	12.4	11.2	9.7	8.6	6.8	5.8	5.2	4.5	3.9	3.4	3	2.6	2.3

”0.6”P18DE, 60Hz, Three Phase or Constant voltage

Number of exposure in series (exp)	Tube load (kW) as a function of the exposure time (seconds) of the individual radiographs of the series														
	0.01	0.02	0.03	0.04	0.05	0.06	0.08	0.1	0.12	0.14	0.16	0.18	0.2	0.225	0.25
10	16.8	15	13.8	13.2	12.5	12.1	11.3	10.8	10.4	9.9	9.6	9.3	8.9	8.7	8.4
20	15	13.2	12.1	11.3	10.8	10.4	9.6	8.9	8.5	8	7.7	7.4	7.1	6.8	6.6
40	13.2	11.3	10.4	9.6	8.9	8.5	7.7	7.1	6.7	6.4	6.2	6	5.8	5.6	5.4
60	12.1	10.4	9.3	8.5	7.8	7.4	6.7	6.3	6	5.7	5.4	5.2	5	4.7	4.4
80	11.3	9.6	8.5	7.7	7.1	6.7	6.2	5.8	5.4	5.1	4.7	4.5	4.3	3.9	3.6
100	10.8	8.9	7.8	7.1	6.6	6.3	5.8	5.4	5	4.6	4.3	3.9	3.6	2.8	2.4
150	9.7	7.8	6.8	6.3	5.9	5.5	5	4.4	3.9	3.3	2.6	2.2	1.8	1.7	1.6

Refer to IEC 60613:2010

HIGH-SPEED SERIAL LOAD RATING TABLE

”1.2”P18DE, 60Hz, Three Phase or Constant voltage

Number of exposure in series (exp)	Tube load (kW) as a function of the exposure time (seconds) of the individual radiographs of the series														
	0.01	0.02	0.03	0.04	0.05	0.06	0.08	0.1	0.12	0.14	0.16	0.18	0.2	0.225	0.25
10	42	38.1	34.8	31.1	28.6	26.8	24.4	22.7	20.8	19.4	18.2	17.2	16.6	16	15.5
20	38.1	31.1	26.8	24.4	22.7	20.8	18.2	16.6	15.7	14.8	14	13.4	13	12.5	12
40	31.1	24.4	20.8	18.2	16.6	15.7	14	13	12.2	11.4	10.7	10	9.4	8.6	7.8
60	26.8	20.8	17.2	15.7	14.4	13.4	12.2	11.2	10	9	8.4	7.3	6.8	6.3	5.8
80	24.4	18.2	15.7	14	13	12.2	10.7	9.4	8.4	7.3	6.5	6	5.6	5.2	4.8
100	22.7	16.6	14.4	13	12	11.2	9.4	7.8	6.8	4.5	5.6	5.2	4.8	4.2	3.6
150	18.7	14.4	12.5	11.2	9.7	8.6	6.8	5.8	5.2	4.5	3.9	3.4	3	2.6	2.3

”0.6”P38DE, 180Hz, Three Phase or Constant voltage

Number of exposure in series (exp)	Tube load (kW) as a function of the exposure time (seconds) of the individual radiographs of the series														
	0.01	0.02	0.03	0.04	0.05	0.06	0.08	0.1	0.12	0.14	0.16	0.18	0.2	0.225	0.25
10	29.4	26.6	24	22.4	21.4	19.7	17.9	16.2	15.1	14	13.2	12.5	11.9	11.3	10.8
20	26.6	22.4	19.7	17.9	16.2	15.1	13.2	11.9	11	10.4	9.9	9.5	9.2	8.7	8.4
40	22.4	17.9	15.1	13.2	11.9	11	9.9	9.2	8.5	7.8	7.2	6.6	6.2	5.8	5.4
60	19.7	15.1	12.5	11	10.2	9.5	8.5	7.6	6.6	6	5.6	5.3	5	4.6	4.3
80	17.9	13.2	11	9.9	9.2	8.5	7.2	6.2	5.6	5.2	4.9	4.6	4.2	3.9	3.6
100	16.2	11.9	10.2	9.2	8.4	7.6	6.2	5.4	5	4.5	4.2	3.9	3.6	3	2.4
150	13.6	10.2	8.7	7.6	6.4	5.7	5	4.3	3.9	3.3	2.7	2.3	2	1.7	1.6

”1.2”P38DE, 180Hz, Three Phase or Constant voltage

Number of exposure in series (exp)	Tube load (kW) as a function of the exposure time (seconds) of the individual radiographs of the series														
	0.01	0.02	0.03	0.04	0.05	0.06	0.08	0.1	0.12	0.14	0.16	0.18	0.2	0.225	0.25
10	62.4	54.8	48	43.8	40.6	38.1	34.3	31.2	29.3	26.9	24.6	23.3	22.2	20.3	18.8
20	54.8	43.8	38.1	34.3	31.2	29.3	24.6	22.2	19.4	17.9	16.8	15.7	14.7	13.6	12.6
40	43.8	34.3	29.3	24.6	22.2	19.4	16.8	14.7	13.1	11.7	10.6	9.9	9.4	8.6	7.8
60	38.1	29.3	23.3	19.4	17.4	15.7	13.1	11.2	9.9	8.8	8	7.3	6.8	6.3	5.8
80	34.3	24.6	19.4	16.8	14.7	13.1	10.6	9.4	8	7.3	6.5	6	5.6	5.2	4.8
100	31.2	22.2	17.4	14.7	12.6	11.2	9.4	7.8	6.8	4.5	5.6	5.2	4.8	4.2	3.6
150	25.6	17.4	13.6	11.2	9.7	8.6	6.8	5.8	5.2	4.5	3.9	3.4	3	2.6	2.3

Refer to IEC 60613:2010

CATHODE EMISSION CHARACTERISTICS

Filament and Emission Characteristics

0.6/1.2P18DE & 38DE

The curves show the emission characteristic under three phase full wave operation. In the case of single phase full wave operation, mA values are decreased by approximately 30% for same filament current.

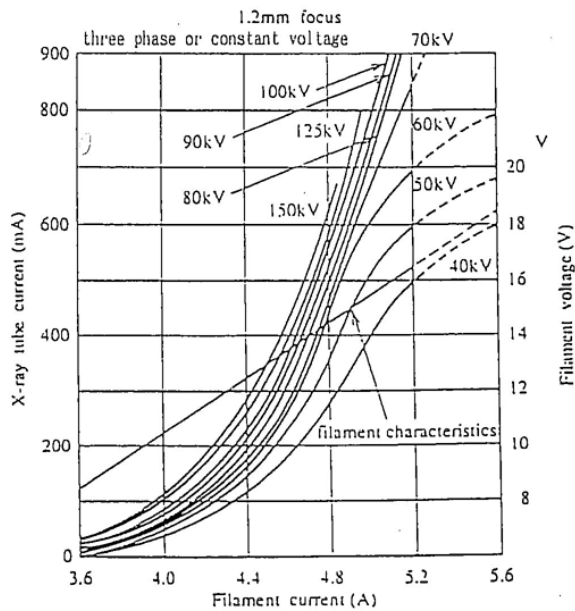
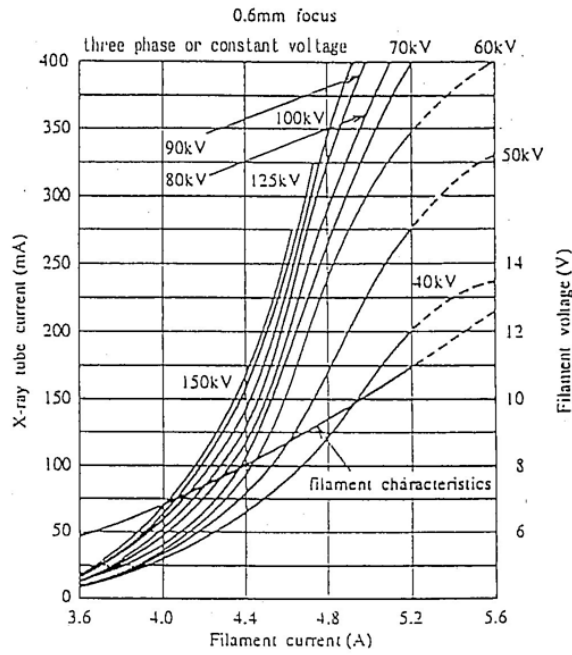

This page is intentionally left blank.