

MTM

# Turbine Gas Meter



livinggas.

metreg   
Metreg Technologies GmbH

# MTM Turbine Gas Meter

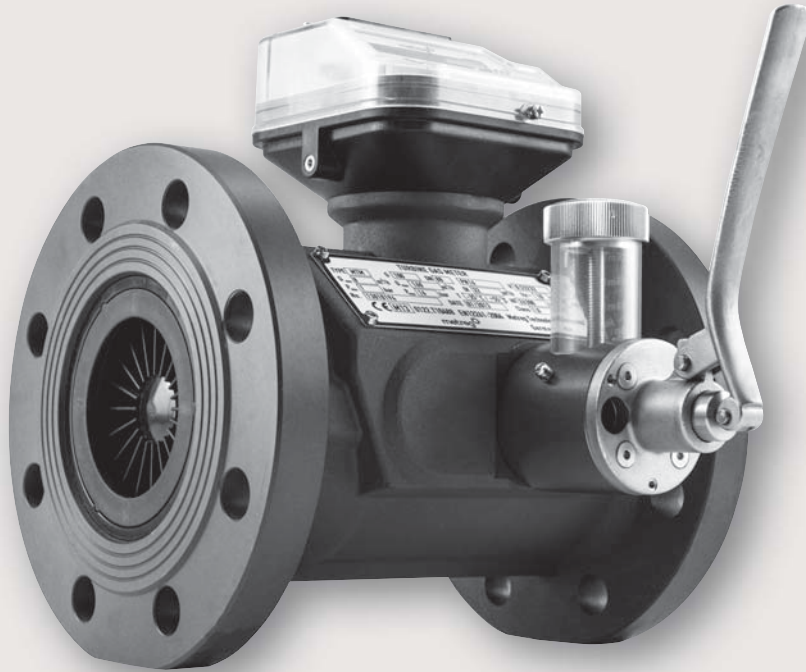

## Applications

The MTM turbine gas meter is fit for use in the custody transfer measurement of gas volumes – especially natural gas in gas transmission stations, in power plants and city stations, in biogas injection stations as well as in various industrial plants wherever custody transfer equivalent accuracy of measurement is requested.

## Key features

- Meter size G 65 to G 4000
- Flow rates from 5 to 6500 m<sup>3</sup>/h
- Nominal sizes from DN 50 to DN 300 (2" to 12")
- Pressure class PN 10 to PN 100 and ANSI Class 150, 300 and 600
- Measuring range 1:20, optional 1:30 depending on operating conditions
- Meter housing made of anodized high strength Aluminum, Carbon Steel or a welded steel construction
- Permanent lubrication of ball bearings up to 16 bar and DN 50 - DN 150 as standard, optional manual lubrication by means of oil pump
- Manual lubrication by means of oil pump as standard for sizes DN 200 - DN 300 and for all MTM turbine meters with operating pressure > 16 bar
- Index head by default made of engineering UV stabilized polymer material, optional made of Aluminum
- Rotating counter (355 °)
- Compact installation by straight inlet pipe  $\geq 2DN$  and outlet pipe  $\geq 1 DN$  with low level perturbations. In case of high level perturbations an additional straight inlet pipe of 2DN is necessary
- Horizontal and vertical mounting positions possible
- Approvals according to MID (2004/22/EG), OIML, PED (PED 97/23/EG), ATEX

## Description and operation

The MTM turbine meter registers the operating volume using an eight-digit mechanical counter. Via pulses the operating volume is transferred to an electronic volume corrector and converted to normal or standard conditions. The MTM turbine is approved for custody transfer according to MID (2004/22/EC) / OIML.

The turbine meter MTM is a volume flow meter. The flow of the gas to be measured causes the turbine rotor to rotate.

The gas flow is narrowed on an annular cross section, is accelerated and directed onto the smooth-running Aluminum rotor. The number of rotations is proportional to the traversed gas volume, the frequency of rotations is proportional to the actual gas flow. The rotation of the rotor is connected to a speed-reducing gear train and transmitted by a magnetic coupling from the gas area to the adjustable roller counter in the atmospheric environment.

The actual volume flow can be transmitted to an electronic volume correctors or data loggers via low frequency (LF-) pulses generated by Reed contacts. An additional anti-tampering contact is placed in the LF pulser unit. This contact is triggered in the presence of strong magnetic fields in case these are used for tampering purposes.

The rotation of the rotor can also be scanned also with one or two high frequency (HF-) sensors. The HF-sensor signal allows the determination of the actual gas flow in high-resolution. It is used in flow computers on its own or in addition to the NF-signal. A damage of the rotor or missing or crooked blades can be detected by a changed frequency pattern.

## Technical specifications

<b>Gas temperature:</b>	+5 °C to +55 °C
<b>Ambient temperature:</b>	+5 °C to +55 °C
<b>Storage temperature:</b>	-25 °C to +55 °C
<b>Operating pressure:</b>	100 bar max., according to housing specification
<b>Protection class:</b>	IP 65
<b>Materials:</b>	
• Meter housing	Aluminum alloy
• Turbine rotor:	Aluminum alloy
• Meter index head:	Engineered UV stabilized polymer, aluminum head as an option
<b>PED-Approval:</b>	Hpi / 222-103-Q-01
<b>ATEX-Approval:</b>	Ex -Zone 1 - $\text{Ex}$ II 2 G c II T4 - TÜV - 94/9/EC Annex 8
<b>MID – Approval:</b>	T10660 - NMI Certin
<b>OIML – Recommendation:</b>	The gas meter of the type MTM meets the requirements of OIML R137-1 & 2: 2012 „gas meters“, confirmed by NMI
<b>Reproducibility:</b>	< 0.1 %
<b>Overload:</b>	Short term up to 1.25 Qmax
<b>Pressure change rate:</b>	< 0.35 bar/s
<b>Counter:</b>	Eight-digit mechanical roller counter
<b>Meter index head:</b>	Standard synthetic material, aluminum as option
<b>Pulse output:</b>	1 LF-pulser (Reed contact) and 1 anti-tampering contact Option: additionally 1 HF-pulser or 2 HF-pulsers
<b>Connections:</b>	
• Pressure:	1 connection with ¼" NPT – thread
• Temperature:	1 thermowell with G ¼" – thread (option)

# MTM Turbine Gas Meter

## Error limits and typical error curve

According to EN 12261 maximum permissible error limits:

$$Q_{\min} \leq Q < 0.2 \cdot Q_{\max}: \pm 2.0 \%$$

$$0.2 \cdot Q_{\max} \leq Q \leq Q_{\max}: \pm 10 \%$$

The turbine meters MTM are all initially calibrated within the standard measurement errors within the maximum permissible errors of EN 12261 and OIML. Reduced measurement errors with only half the maximum permissible error limits are optionally available.

Typical error curve

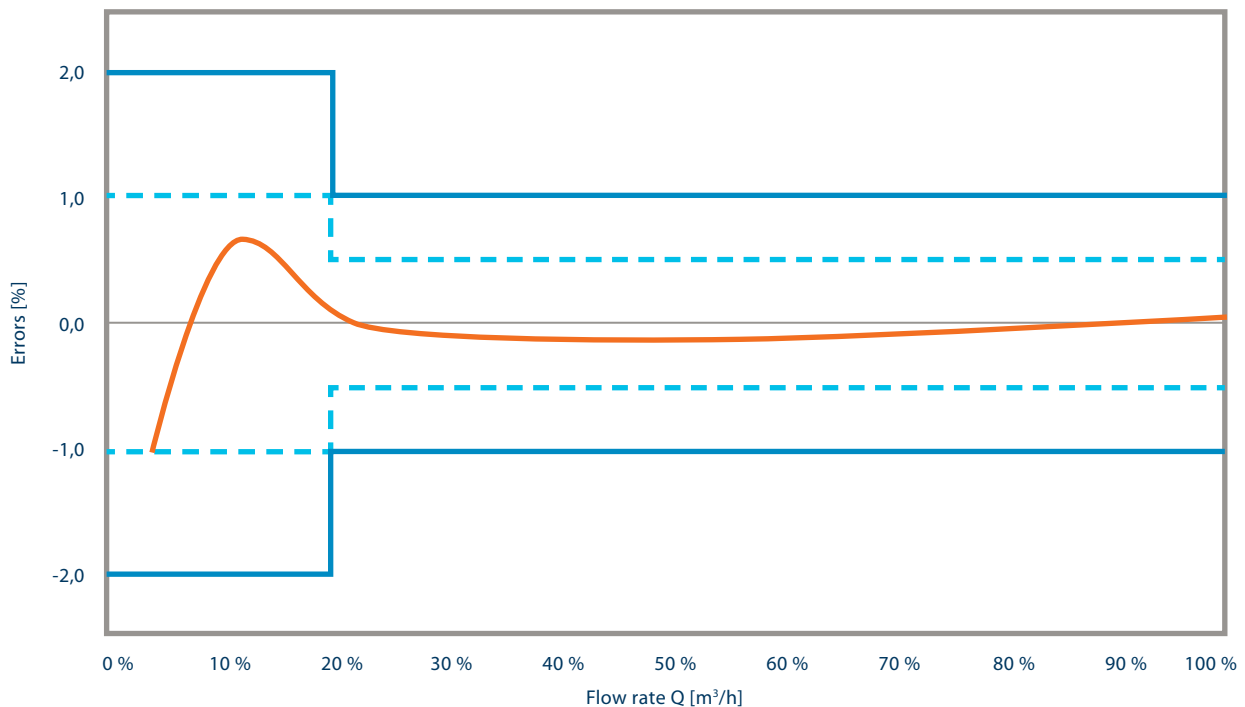

The turbine meters MTM show very stable and reproducible measurement results. The measurement cartridge has been designed to be assembled into the pressure containing housing positioned by soft O-rings. This makes the MTM meter very robust against any torsional and bending stresses resulting out of installation stresses.

The meters can withstand far more than double the specified torsional and bending stresses implied through the installation as defined in EN 12261.

The lifetime durability of the MTM turbine meter is very stable due to the large dimensioned high precision ball bearings "made in Germany" along with the high precision machining of the body and all moving parts on state of the art machines "made in Germany". After machining all aluminum parts, especially the turbine wheel, are hard anodized for less friction and higher resistance to mechanical wear and tear or chemical influences.

## Performance data

DN	G - Size	Q <sub>max</sub> [m <sup>3</sup> /h]	Measuring range 1:20 Pressure range 1-100 bar 8-100 bar		Measuring range 1:30 Pressure range 8-100 bar 16-100 bar		Measuring range 1:50 ** Pressure range 8-100 bar 30-100 bar		HF* [Imp/m <sup>3</sup> ]	NF/L [Imp/m <sup>3</sup> ]	Pressure loss at Q <sub>max</sub> [mbar] and ρ=1 bar abs.	
			Q <sub>min</sub> [m <sup>3</sup> /h]	Q <sub>min</sub> [m <sup>3</sup> /h]	Q <sub>min</sub> [m <sup>3</sup> /h]	Q <sub>min</sub> [m <sup>3</sup> /h]	Q <sub>min</sub> [m <sup>3</sup> /h]	Q <sub>min</sub> [m <sup>3</sup> /h]			Air (ρ=1,2 kg/m <sup>3</sup> )	Natural gas (ρ=0,83 kg/m <sup>3</sup> )
50	65	100	5		3,3				105000	10	13,7	8,81
80	100	160		8		5		3,2	26000	1	4,4	2,83
80	160	250	12,5		8		5		26000	1	8,7	5,60
80	250	400	20		13		8		26000	1	22,1	14,22
100	160	250		12,5		8,3		5	13500	1	5,0	3,22
100	250	400	20		13		8		13500	1	9,6	6,18
100	400	650	32,5		20		13		13500	1	25,0	16,09
150	400	650		32,5		22		13	5000	1	3,6	2,32
150	650	1000	50		33		20		5000	1	10,4	6,69
150	1000	1600	80		53		32		5000	1	21,4	13,77
200	650	1000		50		33		20	2200	1	1,1	0,71
200	1000	1600	80		53		32		2200	1	2,8	1,80
200	1600	2500	125		83		50		2200	1	6,5	4,18
250	1000	1600		80		53		32	1900	0,1	6,2	3,99
250	1600	2500	125		83		50		1900	0,1	12,5	8,04
250	2500	4000	200		133		80		1900	0,1	12,8	14,67
300	1600	2500		125		83		50	1200	0,1	4,6	2,96
300	2500	4000	200		133		80		1200	0,1	10,0	6,43
300	4000	6500	325		216		130		1200	0,1	22,1	14,22

\*\* in Vorbereitung

\* Der Impulswert kann variieren und wird für den Zähler bei der Eichung genau bestimmt

\* The absolute number of the pulses depends on the meter size and the single meter itself. The stated values are of typical size. Exact values determined by calibration of the meter are located on the nameplate.

The turbine meters MTM are manufactured with large measurement ranges due to the precision machining of the parts and a very reproducible assembly process. The standard calibrated measurement range for the MTM is 1:20 under atmospheric conditions. An extended measurement range of 1:30 is optionally available. Measurement ranges of 1:50 are under preparation.

The pressure loss of the MTM turbine meter is minimized through a fluid dynamically optimized inlet diffusor, very low manufacturing tolerances and the high precision, low friction ball bearings. The optimized flow conditions allow a minimal straight inlet pipe of 2 DN for low level perturbations and only 2 DN additional straight inlet piping under severe perturbations according to OIML standards. MTM turbine meters housings are manufactured on a standard basis with raised face (RF) flanges according to DIN/EN 1092-1 or ANSI B 16.5 for class 150/300/600 with a maximum operating pressure of 100 bar/ 10 MPa.

More technical details, especially for commissioning and operation, please refer to the operation manual of the MTM turbine meter.

# MTM Turbine Gas Meter

## Housing materials

DN [mm]	Pressure class							
	PN 16	PN 25	PN 40	PN 63	PN 100	ANSI 150	ANSI 300	ANSI 600
50	Aluminium/Carbon Steel	Carbon Steel	Carbon Steel	Carbon Steel	Carbon Steel	Carbon Steel	Carbon Steel	Carbon Steel
80	Aluminium/Carbon Steel	Carbon Steel	Carbon Steel	Carbon Steel	Carbon Steel	Carbon Steel	Carbon Steel	Carbon Steel
100	Aluminium/Carbon Steel	Carbon Steel	Carbon Steel	Carbon Steel	Carbon Steel	Carbon Steel	Carbon Steel	Carbon Steel
150	Aluminium/Carbon Steel	Carbon Steel	Carbon Steel	Carbon Steel	Carbon Steel	Carbon Steel	Carbon Steel	Carbon Steel
200	Aluminium/Carbon Steel	Carbon Steel	Carbon Steel	Carbon Steel	Carbon Steel	Carbon Steel	Carbon Steel	Carbon Steel
250	Carbon Steel	Carbon Steel	Carbon Steel	Carbon Steel	Carbon Steel	Carbon Steel	Carbon Steel	Carbon Steel
300	Carbon Steel	Carbon Steel	Carbon Steel	Carbon Steel	Carbon Steel	Carbon Steel	Carbon Steel	Carbon Steel

## Meter design

The pressure containing housing (1) is very robust against torsional or bending forces due to the large cross sections. The Aluminum turbine wheel (2) is machined out of full material on a 5 axis machine, dynamically precision balanced, and hard anodized. The computer optimized profile of the turbine blades in combination with the fluid dynamic optimized inlet flow straightener (5) provide for a very stable measurement characteristic also under high pressure operating conditions. The high precision ball bearings "made in Germany" with minimal bearing play ensure a smooth running turbine wheel with a high load capacity. The measuring cartridge (7) is positioned in the pressure containing housing by O-rings. This design feature also creates a circular room with absolute static operating pressure for very precise pressure measurement without any dynamic flow influences. The oil lubrication of the ball bearings is ensured through the lubrication pump (6). The turning of the turbine wheel is transmitted via a low friction gear train and a pressure stable and leak tight magnetic coupling to the eight digit mechanical counter (4) with an environmental protection class of IP 65.

The turbine meter MTM can be installed horizontally and vertically up or down due to the 355° turnable index head. The exchangeable low frequency (LF) switch in combination with an anti-tampering contact provides for the electrical connection to an electronic volume corrector and a possible further AMR device. The complete design of the MTM turbine meter has been aimed to be very robust in combination with highest measurement performance.

- 1 pressure containing housing
- 2 turbine wheel
- 3 LF-Pulser and anti tampering unit
- 4 index head and 8 digit counter
- 5 flow straightener
- 6 lubrication oil pump
- 7 measuring cartridge

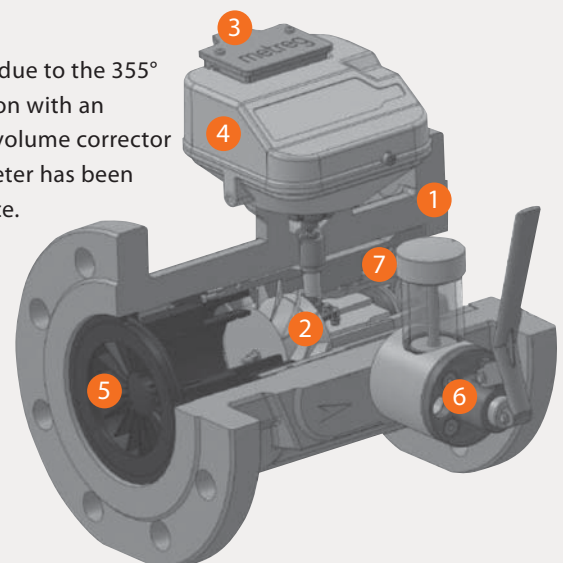

## Dimensions, weights and connections

DN [mm]	Approx. weight [kg]							
	PN 16	PN 25	PN 40	PN 63	PN 100	ANSI 150	ANSI 300	ANSI 600
50	7	15	15	17	31	13	15	22
80	10	25	25	27	58	23	26	47
100	13	36	36	38	51	35	39	56
150	77	123	123	140	168	120	135	176
200	94	139	151	173	203	136	161	210
250	140	170	194	218	285	164	203	302
300	163	193	230	262	368	195	249	356

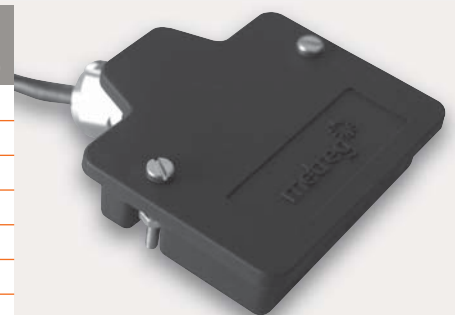

## Dimensions, weights and connections

DN [mm]	Pressure class	Housing dimensions			
		DN [mm]	H [mm]	C [mm]	L [mm]
50	PN 16	52	163	75	150
	PN 25, PN 40, PN 63, Class 150, Class 300	52	168	75	150
	Class 600	52	185	75	150
80	PN 16	81	170	101	240
	PN 25, PN 40, PN 63, Class 150, Class 300	81	189	101	240
	Class 600	81	204	101	240
100	PN 16	101	180	120	300
	PN 25, PN 40, PN 63, Class 150, Class 300, Class 600	101	199	120	300
150	PN 16	151	200	180	450
	PN 25, PN 40, PN 63, Class 150, Class 300, Class 600	151	234	180	450
200	PN 16, PN 25, PN 40, PN 63, Class 150, Class 300, Class 600	201	240	255	600
250	PN 16, PN 25, PN 40, PN 63, Class 150, Class 300, Class 600	251	267	250	750
300	PN 16, PN 25, PN 40, PN 63, Class 150, Class 300, Class 600	301	293	308	900

MTM turbine meters housings are manufactured on a standard basis with raised face (RF) flanges according to DIN/EN 1092-1 or ANSI B 16.5 for class 150/300/600 with a maximum operating pressure of 100 bar/ 10 MPa.

More technical details, especially for commissioning and operation, please refer to the operation manual of the MTM turbine meter.

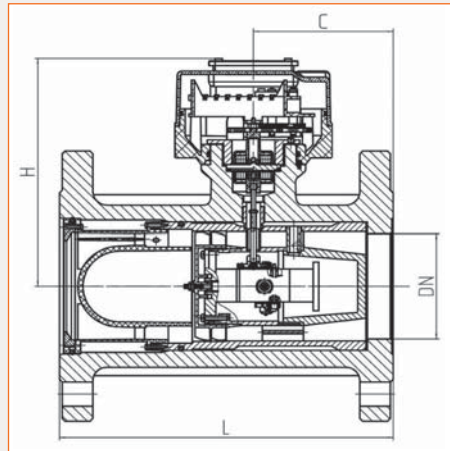

## Connections

DN [mm]	Flanges with threaded holes							
	DIN EN 1092-1				ANSI B 16.5			
	PN 16	PN 25	PN 40	PN 63	PN 100	ANSI 150	ANSI 300	ANSI 600
50	4 x M12	4 x M16	4 x M16	4 x M20	4 x M24	4 x 5/8"	8 x 5/8"	8 x 5/8"
80	4 x M16	8 x M16	8 x M16	8 x M20	8 x M24	4 x 5/8"	8 x 3/4"	8 x 3/4"
100	8 x M16	8 x M16	8 x M16	8 x M24	8 x M27	8 x 5/8"	8 x 3/4"	8 x 7/8"
150	8 x M16	8 x M20	8 x M20	8 x M30	12 x M30	8 x 3/4"	12 x 3/4"	12 x 1"
200	8 x M20	8 x M24	12 x M24	12 x M33	12 x M33	8 x 3/4"	12 x 7/8"	12 x 1 1/8"
250	12 x M24	12 x M27	12 x M30	12 x M33	12 x M36	12 x 7/8"	16 x 1"	16 x 1 1/4"
300	12 x M24	16 x M27	16 x M30	16 x M33	16 x M39	12 x 7/8"	16 x 1 1/8"	20 x 1 1/4"



Metreg Technologies GmbH  
Tränkeweg 9  
15517 Fürstenwalde  
Germany

MTM\_EN\_19.09.2014

© 2014 Metreg Technologies GmbH • Design: [www.reidelsoltaugrafikdesign.de](http://www.reidelsoltaugrafikdesign.de)

All rights reserved. Subject to technical changes.

[www.bellflowsystems.co.uk](http://www.bellflowsystems.co.uk)

**BELL**  
*Flow Systems*