



STEEL BALL VALVES

# Installation, operation and maintenance manual



# Contents

<b>1. General</b>	<b>4</b>
<b>2. Valve identification</b>	<b>5</b>
<b>3. Unloading and storage</b>	<b>6</b>
<b>4. Valve installation</b>	<b>7</b>
4.1 Installation of valve with weld connections	8
4.1.1 Steel ball valves < DN 300 reduced bore	8
4.1.2 Steel ball valves ≥ DN 300 reduced bore	9
4.2 Installation of valve with flanges	10
4.3 Installation at the end of pipeline	11
4.4 Before commissioning	12
4.5 Commissioning and Pressure testing	12
4.6 Flushing	12
<b>5. Gear and actuator disassembly and installation</b>	<b>13</b>
5.1 Disassembly and reinstallation of ProGear/Rotork manual gear	13
5.2 Adjustment of ProGear/Rotork manual gear	14
5.3 Disassembly and reinstallation of AUMA electric actuator	15
5.4 Adjustment of the mechanical limits of AUMA electric actuator	16
5.5 Assembly/disassembly of pneumatic actuator	17
5.6 Assembly/disassembly of hydraulic actuator	17
<b>6. Maintenance</b>	<b>18</b>
6.1 Replacing the O-ring seal of stem in valves DN 65–150	19
6.2 Replacing the O-ring seal of stem in valves with actuators DN 65–150	20
6.3 Replacing the O-ring seal of stem in valves DN 200–300	21
6.4 Replacing the O-ring seal of stem in valves DN 350–500	22
<b>7. Appendices</b>	<b>24</b>
7.1 Parts list for steel ball valves < DN 200	24
7.2 Parts list for steel ball valves ≥ DN 200	25
7.3 Coupling dimensions, reduced bore ball valves DN 65–500 with actuators	26
7.4 Coupling dimensions, full bore ball valves DN 50–400 with actuators	27
7.5 Maximum allowed operating torques	28
7.6 Kv value chart	29



## NOTE:

This manual must be read and its instructions must be followed when installing, operating and/or performing maintenance on the valve as well as its manual gear or actuator.

These instructions are of general nature and do not cover all possible operating scenarios. For more specific guidance on the installation, operation and maintenance of the valve or its suitability for an intended use, please contact the manufacturer.

Vexve Oy reserves the right to make alterations to these instructions.

Vexve Oy is not responsible for damages caused by incorrect transportation, handling, installation, operation or maintenance. Furthermore, Vexve Oy is not responsible for damage caused by foreign objects or impurities.

## Warranty

Warranty according to Vexve Oy's "General terms and conditions of sale".

The warranty covers manufacturing and material faults. The warranty does not apply to damages caused by inappropriate installation, operation, maintenance, or storage ie. these instructions must be followed for the warranty to apply. Vexve Oy requires that any faulty products under warranty are to be returned to the factory for inspection. Only after the product has been found faulty, Vexve Oy can grant compensation.

Please refer to Vexve Oy's "General terms and conditions of sale" for detailed warranty clauses. The document is available from the manufacturer.

## Warnings and symbols

Ignoring the warnings and symbols may lead to serious injury or equipment damage. Persons authorized to use the equipment must be familiar with the warnings and instructions.

Appropriate transportation, storage and installation as well as careful commissioning are essential to ensure faultless and stable operation.

The following symbols are used in this manual to draw attention to actions essential to ensure the proper use and safety of the device.



## Meaning of the symbol: NOTE

The NOTE symbol is used for actions and functions that are essential for the proper use of the device. Ignoring this symbol may have harmful consequences.



## Meaning of the symbol: WARNING

The WARNING symbol is used for actions and functions that, if carried out incorrectly, may lead to injury or equipment damage.

# 1. General

Vexve Oy's fully welded steel ball valve (colour blue) is designed for clean mediums and to be used in district heating and district cooling pipelines. The steel ball valve can also be used in heating and cooling systems and applications where the water is oxygen free. Vexve Oy's steel ball valve is also suitable for oil piping systems.

Vexve Oy's steel ball valve can be used within the following temperature-pressure range. Please note that the maximum allowable working pressure depends on the operating temperature.

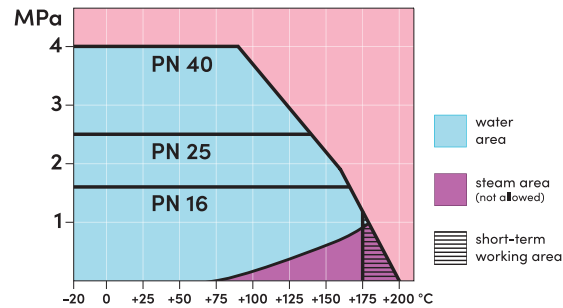
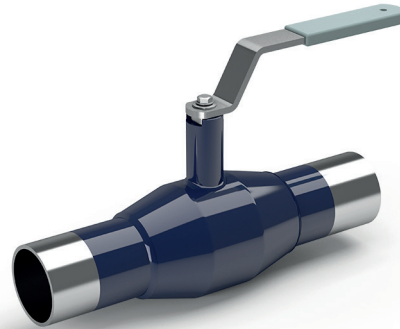

Chart 1.

Pressure-temperature chart  
DN 65-500 reduced bore



**NOTE:**

When intending to use the valve for other media or applications please contact Vexve Oy to ensure its suitability.



**NOTE:**

Dimensions in this manual generally refer to reduced bore ball valves. Manual can be utilized also as a full bore ball valve's user manual. However must be noticed that a full bore ball valve follows user instructions of a one size bigger reduced bore ball valve. For example a DN 200 full bore ball valve follows user instructions of a DN 250 reduced bore ball valve.

Parts lists for Vexve Oy's steel ball valves are presented in Appendices 7.1 and 7.2

For detailed technical information including dimensions and weights, torques, Kv-values etc please refer to [www.vexve.com](http://www.vexve.com).

# 2. Valve identification

The identification plate locates at the valve body. It has the following information:

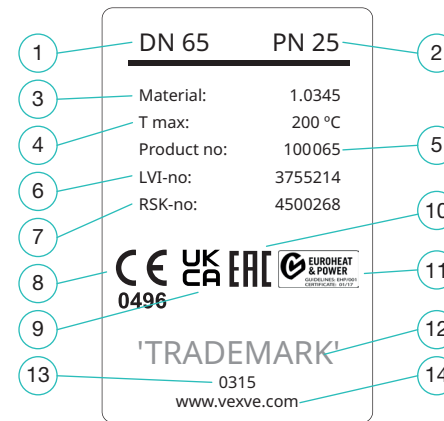

Figure 1. Identification plate.

1. Valve DN size
2. Pressure class
3. Valve Body Material
4. Maximum Allowable Temperature
5. Product number
6. Identification code for Finnish HVAC products
7. Identification code for Swedish HVAC products
8. CE-Mark and the number of the notified body
9. UKCA-marking
10. Eurasian conformity valve certification
11. EHP003-marking
12. Trademark
13. Manufacturing date
14. Manufacturer's Website

## 3. Unloading and storage

Check that the contents of the delivery is as ordered. Check that the valve and related equipment have not been damaged during transportation.

Store the valve carefully before installation, preferably in a well-ventilated, dry place, on a shelf or a wooden grid to protect it from rising damp.

Protect bare metal surfaces, shaft parts, and flange surfaces with anti-corrosive agent before storage.

The valve must be transported to the installation site in a sturdy package. Do not remove the flow port protectors before installation. Protect the valve from sand, dust, and other impurities.

Use lifting ropes when lifting the large size valves. It is forbidden to lift the valve by its actuator or stem (see Figure 2).



### NOTE:

Take the weight of the valve into account when handling it.

When delivered, the valve is in the open position. During storage, the valve must also be in the open position.

Maximum recommended storage time is two years. If the valve is stored for more than two years, it should be operated and cleaned yearly.

### Packaging:

Vexve Oy's products are protected during transportation with special packaging. The packaging consists of environmentally friendly materials that are easy to sort and recycle.

Recycling the packaging materials at designated waste collection points is recommended.

The following packaging materials are used: wood, cardboard, paper, and polyethylene sheets.

## Recycling and disposal

Nearly all parts of the valve are made of recyclable materials. The material type is marked on most parts. Separate recycling and disposal instructions are available from the manufacturer. The valve can also be returned to the manufacturer for recycling and disposal against a fee.

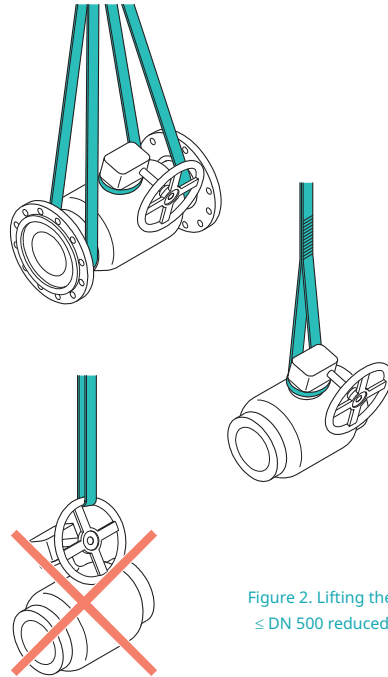

Figure 2. Lifting the valve  $\leq$  DN 500 reduced bore



### WARNING:

The valve can not be lifted from the lifting lugs at a temperature below  $-20$  C. When storing/transporting at a temperature below  $-20$  C, it must be ensured that the lifting lugs are not subject to a strong impact.

## 4. Valve installation



### WARNING:

Incorrect installation may result in serious personal injury and it may damage or cause malfunction of the equipment. These instructions must therefore be followed carefully when installing the valve.

These general instructions do not cover all possible operating scenarios. For more specific guidance on the use of the valve or its suitability for an intended use, please contact the manufacturer.

- Do not remove the flow port protectors before installation. Keep the valve protected from sand, dust, and other impurities.
- If the valve was delivered with the actuator installed, avoid removing the actuator during installation.
- Incorrect re-installation or adjustment of the actuator will result in a high risk of damage and leakage.
- Exercise extreme caution when testing the valve before installation in the pipeline.
- The valve or valve assembly must not be lifted from the actuator. If the valve is equipped with lifting lugs, use them. Dropping or incorrect lifting of the valve can result in personal injury or equipment damage.
- Use one of the allowed lifting methods shown in Figure 2.



### NOTE:

The valve must be used only in applications for which it is intended.

Prior to installation:

- Remove the flow port protectors and check that the inside of the valve is clean.



### NOTE:

It is recommended to install the valve with the stem horizontal or vertically upwards.



### WARNING:

The pipeline and valve shall be carefully cleaned prior to installation as any welding debris or other impurities can damage the valve.

## 4.1 Installation of valve with weld connections

### 4.1.1 Steel ball valves < DN 300 reduced bore

Recommended welding method is manual metal arc welding. Recommended welding rod is ESAB OK 48.00 or equal (standard: EN ISO 2560-A; classification: E 42 4 B 42 H5).

Valve size DN 125 and bigger must be welded to the pipeline by using electric welding.

#### Welding

Do not overheat the valve. Use cooling during the welding. Use wet fabric to protect the valve seat from excess heat during the welding. The welder should have the proper qualification to do this kind of welding procedures.

The valve must first be bridged to the pipeline using spot welding, with 4–8 seams alternately on opposite sides of the valve.

During welding the ground must be connected to the pipe of the valve body or the pipeline. Ground cable should be connected to the pipe on the same side as the welding seam. Otherwise the current may damage the valve seal. Never connect the ground to the valve neck, top flange, handle or actuator.

#### When valve is installed in a horizontal position:

When welding the valve, it must be in the open position in order to protect the surface of the ball from welding contamination (See Figure 3.4).

#### When valve is installed in a vertical position:

When making the upper seam welding, the valve must be open in order to protect the surface of the ball from welding contamination (See Figure 3.1).

When making the lower welding seam the valve must be closed to avoid the overheating of the valve (See Figure 3.3).

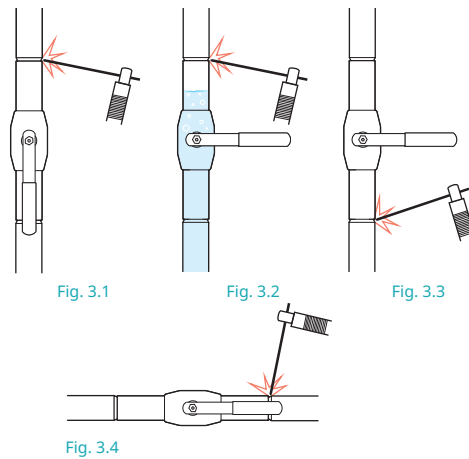

Figure 3.1. Vertical position

When welding the upper seam the valve must be in open position.

Figure 3.2. Vertical position

When welding the upper seam and lower side of the valve is pressurized the valve must be in closed position. Also cover the seal and ball with a water cushion of minimum 40 mm.

Figure 3.3. Vertical position

When welding the lower seam the valve must be in closed position.

Figure 3.4. Horizontal position

The valve must be in open position.

Cool down the valve (after welding) before normal operation. The valve may not be opened or/and closed after the welding before it has cooled down.

### 4.1.2 Steel ball valves $\geq$ DN 300 reduced bore



#### NOTE:

Electric welding must be used to weld the valve in place.

- Recommended welding method is manual metal arc welding. Recommended welding rod is ESAB OK 48.00 or equal (standard: EN ISO 2560-A; classification: E 42 4 B 42 H5).
- A valve may be welded only by an authorized mechanic, following valid norms and standards.
- The valve must remain open during installation and welding to ensure that welding residue does not damage the seal surfaces.
- The ends of the pipes must be parallel to the valve and correctly aligned.
- The length of the valve must be the same as the distance between the pipe ends, taking into consideration the welding gaps.
- Diameter and wall thickness of the pipes must be compatible with the welding ends of the valve.
- Recommended installation position for the valve is with the shaft in the vertical or horizontal position.

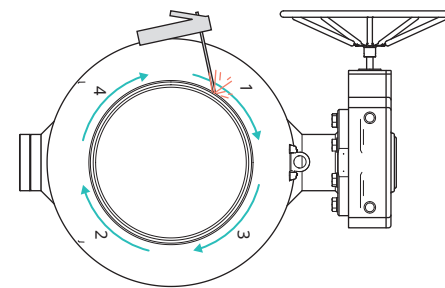

Figure 4. Welding the seams



#### NOTE:

The recommended installation position for the valve is with the shaft in the vertical or horizontal position.

- The valve must first be bridged to the pipeline using spot welding, with 4–8 seams alternately on opposite sides of the valve.
- Then the seams between the bridges are welded as shown in Figures 4. and 5. Welding order: 1-2-3-4.
- Any lid welding must be carried minimum at 200 mm from the valve seam.
- During welding the ground must be connected to the pipe of the valve body or the pipeline. Ground cable should be connected to the pipe on the same side as the welding seam. Otherwise the current may damage the valve seal. Never connect the ground to the valve neck, top flange or actuator.

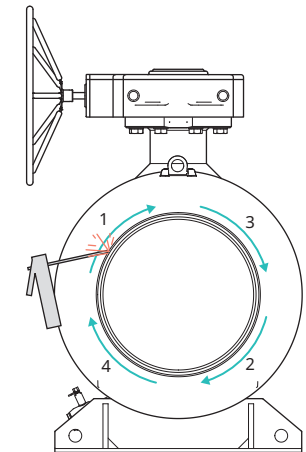

Figure 5. Welding the seams

## 4.2 Installation of valve with flanges

- Valve may be installed only by an authorized mechanic, following valid norms and standards.
  - The valve must remain open during installation to ensure that any residue or dirt does not damage the sealing faces.
  - The sealing faces of the pipe flanges must be parallel to the valve sealing faces and correctly aligned.
  - The length of the valve must be the same as the distance between the flanges in the pipe line, taking into consideration the gasket.
  - The flanges in the pipeline must be compatible with valve flanges. For detailed information please refer to the standard EN1092-1.
- The bolts and nuts used on installation must be selected to match operating conditions at installation location. Bolts and nuts must also fulfill requirements of the pressure, temperature, flange material and gasket. For detailed information please refer to the standards EN 1515-1, EN1515-2 and 1515-4.
  - The gasket used on installation must be selected to match operating conditions, temperature, pressure and medium. Gasket dimensions must be compatible with sealing faces of the flanges. For detailed information please refer to the standard EN1514.
  - It is recommended to install the valve with the stem horizontal or vertically upwards.

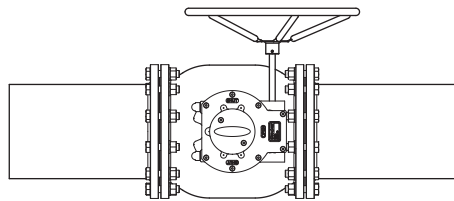

Figure 6. Horizontal installation

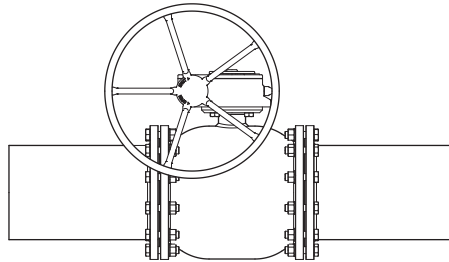

Figure 7. Vertical installation

## 4.3 Installation at the end of pipeline



### NOTE:

Do not use the valve at the end of the pipeline – a blank flange must always be installed after the valve (see Figure 8. and 9.).

When the valve is installed at the end of the pipeline, there is a risk of corrosion-causing oxygen-rich water or air collecting on the empty rear side of the valve. To prevent corrosion, the space after the valve must be filled with oxygen-free water.

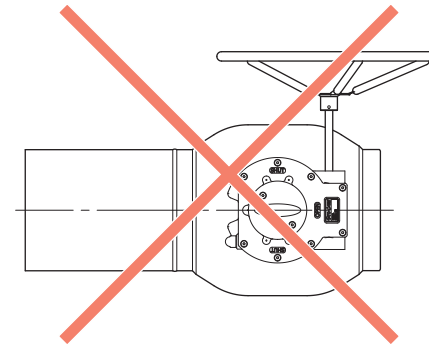

Figure 8. Do not use the valve at the end of the pipeline

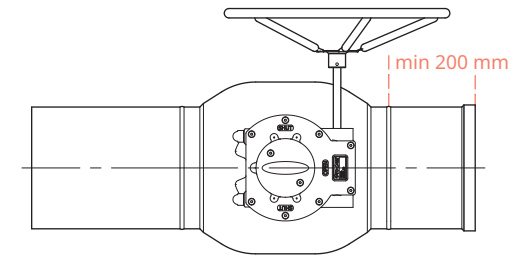

Figure 9. Blank flange

Min. 200 mm pipe must be installed between the valve and the blank flange



### NOTE:

If the valve is located near to the blind flange at the end of the pipeline, valve must be in the fully open position to prevent a closed space from forming between the valve and blind flange. If water in the closed space expands (for example due to temperature), it may damage the valve.

## 4.4 Before commissioning

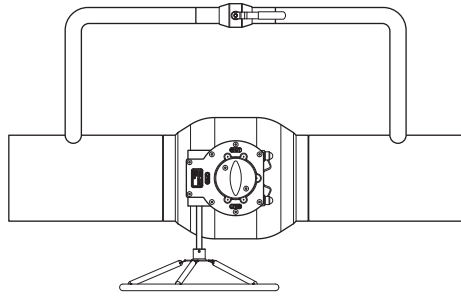

To avoid pressure shocks and to reduce the forces caused by opening the valve under pressure, it is recommended to use a by-pass valve in connection with ball valves of size DN 150 and larger (see Figure 10).

Figure 10. By-pass valve

## 4.5 Commissioning and Pressure testing

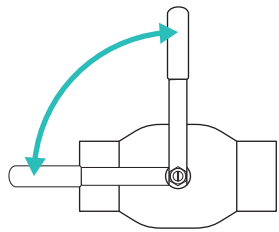
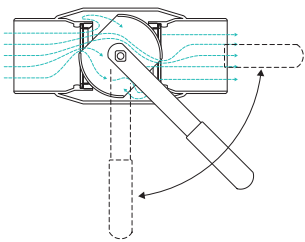

Figure 11. Check that the valve is either in an open or close position

Exceeding of permitted values marked on the valve may damage the valve and, in the worst case, cause uncontrolled venting of the pressure. This leads to equipment damage and possibly also to personal injuries. The largest allowable testing pressure is 1,1xPN, when the valve is closed. During the pipeline pressure testing (1,5xPN), the valve must be open.

The shut-off valves are designed to be fully open or close. Check that the valve is either in an open or close position against the stopper. Do this either by turning the handle 90 degrees or if the valve is equipped with a manual gear or an actuator, operate the valve with the help of it.

## 4.6 Flushing



Pipeline needs to be flushed carefully after the valve installation.

During flushing, calmly operate the valve a few times fully open - fully closed, in order to flush out any impurities from the inside of the valve and sealing surfaces.

Figure 12. Pipeline needs to be flushed after valve installation

# 5. Gear and actuator disassembly and installation



### NOTE:

Avoid removing the actuator/gear from the valve. The actuator/gear has been calibrated at the factory to ensure that the valve is tight. If the actuator/gear is removed, it may have to be re-calibrated.

Vexve Oy accepts responsibility only for actuators/gears installed by Vexve Oy.

Refer to the separate adjustment instructions, available from the manufacturer.



### WARNING:

The manual gear or actuator may not be removed or dismantled if the valve is pressurized! It is recommended to use the special actuator removal tools!

Incorrect disconnection may cause serious personal injuries as well as malfunction and damage to the equipment. Extreme caution must be exercised during the disconnection!

Do not use too high torques to operate the valve. Too high torques can damage the valve or the actuator/gear!

## 5.1 Disassembly and reinstallation of ProGear/Rotork manual gear

Part numbers mentioned in this chapter refer to the figure 13.

### Disassembly:

1. Turn the valve to the open position before removing the gear. Valve opens when you turn the hand wheel of the gear counterclockwise.
2. Turn the hand wheel slightly towards the close position (clockwise) to release forces between the valve and the gear in order to make it easier to remove the gear. To do this, turn the hand wheel only that much that it rotates easily.
3. Remove the bolts (2) of the position indicator plate and remove the position indicator plate (3). Mark the position of the valve stem to the bush of the gear (1) in order to make it easier to reinstall the gear back into the right position.
4. Remove the attachment bolts of the gear and then remove the gear.

### Reinstallation:

5. When reinstalling the manual gear back to valve, check that the gear is in the right position .
  - If the gear is installed back to its original position there is no need to adjust the gear settings .
  - If the gear is turned 180 degrees from its original position, you must carefully check that the valve closes and opens correctly. If the mechanical limits (parts 4-7) are not correct you must adjust the gear as described in the chapter "5.2 Adjustment of manual gear".
6. Install the gear back to the valve and tighten the attachment bolts.
7. Check that the valve opens and closes correctly. If the mechanical limits (parts 4-7) are not correct you must adjust the gear as described in the chapter "5.2 Adjustment of manual gear".

## 5.2 Adjustment of ProGear/Rotork manual gear

Part numbers mentioned in this chapter refer to the figure 13.

Remove the plastic dust caps (4) from the top of the mechanical limits. Open the locking nuts (5) and loosen the adjusting screws (6 & 7)

1. Turn the valve to the open position. Valve opens when you turn the hand wheel of the gear counterclockwise. Valve is in the open position when the flow port of the valve ball is concentric with the seat of the ball.
2. Tighten the OPEN position adjusting screw (7) until it stops turning. Fix it with the locking nut (5) and put the dust cup in its place (4).
3. Turn the valve 90 degrees to the closed position. Valve closes when you turn the hand wheel of the gear clockwise.
4. Tighten the CLOSE position adjusting screw (6) until it stops turning. Fix it with the locking nut (5) and put the dust cup in its place (4).
5. Check that the valve opens and closes correctly.

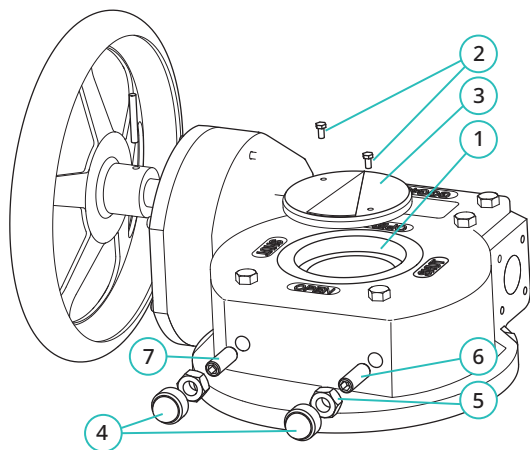

Figure 13. Manual gear

## 5.3 Disassembly and reinstallation of AUMA electric actuator

Part numbers mentioned in this chapter refer to the figure 14.

### Disassembly:

1. Before removing the actuator, turn the valve to the open position either electrically or manually by rotating the hand wheel (3) of the motor unit (2) counterclockwise.
2. Turn off the power supply of the actuator.
3. Turn the hand wheel (3) of the motor unit (2) slightly towards the close position (clockwise) to release forces between the valve and the actuator in order to make it easier to remove the actuator. To do this, turn the hand wheel (3) only that much that it rotates easily.
4. Remove the bolts (4) of the position indicator plate. Remove the position indicator plate (5), the retaining ring (6) and the cover plate (7).
5. Before removing the actuator, mark the position and the place of the bushing (8) in relation to the actuator and the valve.
6. Remove the attachment bolts of the actuator and remove the actuator. The bushing (8) will stay at the valve stem.

### Reinstallation:

7. When reinstalling the actuator back to the valve, check that the actuator is in the right position.
  - If the actuator is installed back to its original position there is no need to adjust the actuator settings.
  - If the actuator is turned 180 degrees from its original position, you must carefully check that the valve closes and opens correctly. If the actuator limits are not correct you must adjust the actuator as described in the chapter 5.4 "Adjustment of the mechanical limits of AUMA electric actuator".
8. Install the actuator back to the valve and tighten the attachment bolts of the actuator.
9. Check that the valve opens and closes correctly. If the actuator limits are not correct you must adjust the actuator as described in the chapter 5.4 "Adjustment of the mechanical limits of AUMA electric actuator".

## 5.4 Adjustment of the mechanical limits of AUMA electric actuator

Part numbers mentioned in this chapter refer to the figure 14.

If the actuator is already installed to the valve, you can skip the points 1-8

1. Vexve Oy's ball valves are delivered from the factory in the open position. If the valve has been operated so that it is in some other position, turn the valve to the open position. Remove the device (handle/actuator) that you used to operate the valve.
2. Check that the valve stem is intact and clean. Check also that the key of the valve stem is properly in its groove.
3. Put the bushing (8) on the valve stem and set it to the right depth. Check that the overlap between the valve stem and the bushing is long enough. Usually a proper gap between the bushing and the actuator flange of the valve is about 10 mm.
4. Tighten the locking screw (9) with an Allen key.
5. Turn the actuator to the open position.
6. Install the actuator on the valve in the preferred position. The gear unit (1) must fit the bushing (8) easily and you must not force it in its place.
7. Grease the attachment screws of the actuator. Put all the washers and the attachment screws first loosely in their places and finally tighten them up.
8. (If the motor unit (2) is not installed to the gear unit (1), install it now. Put all the washers and the attachment screws first loosely in their places and finally tighten them up).
9. Turn the hand wheel (3) a couple of revolutions clockwise. Remove the attachment screws (10) of the limiting bush (11).
10. (Set the position and torque limit of the motor unit (or control unit if included) according to separate AUMA's instructions).
11. Turn the valve to the open position.
12. Turn the limiting bush counterclockwise until it stops turning. Then turn it backwards (clockwise) app. 1/8 turn.
13. Pull the limiting bush out and put it back in its place so that the holes of it will match the holes of the gear unit. Fasten the limiting bush (11) tightly with the attachment screws (10).
14. Check that the actuator works properly.

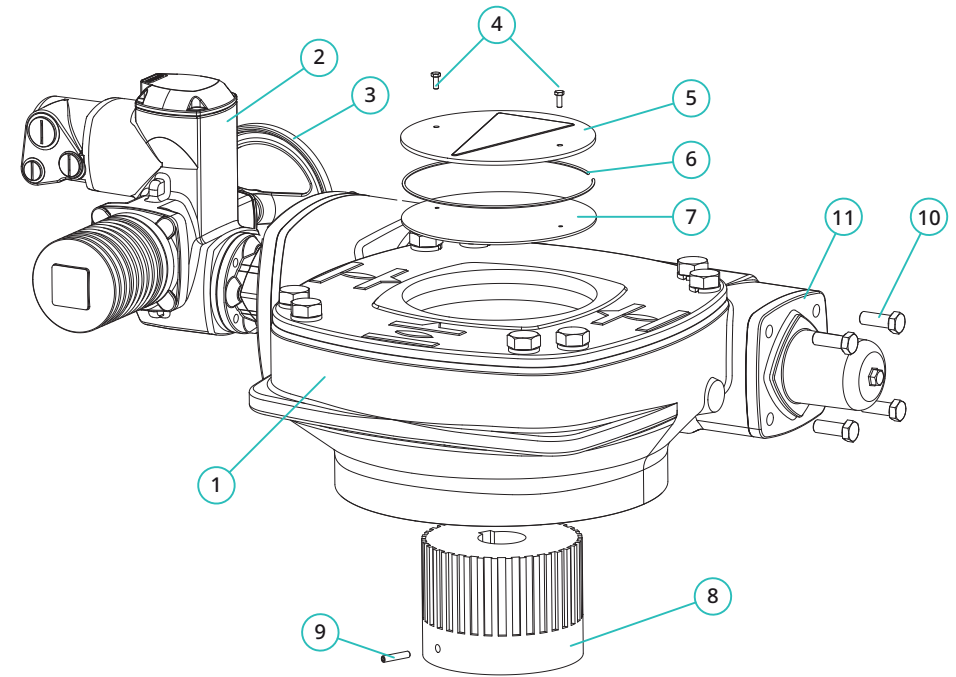

Figure 14. Electric actuator

## 5.5 Assembly/disassembly of pneumatic actuator

Please refer to the separate installation/adjustment instructions, available from the manufacturer.

## 5.6 Assembly/disassembly of hydraulic actuator

Please refer to the separate installation/adjustment instructions, available from the manufacturer.

# 5.6 Actuator installation positions

Ball valve / manual gear, default position AR, see Figure 27.  
 Ball valve / electric actuator, default position ABR, see Figure 28.

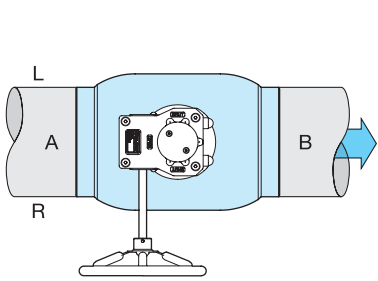

Figure 27. Installation position AR

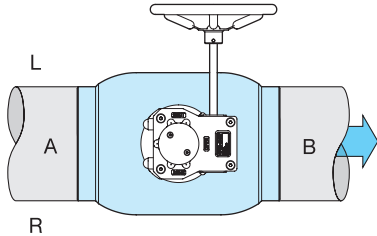

Figure 28. Installation position AL

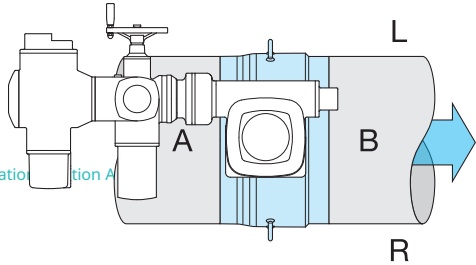

Figure 29. Installation position AAL

Figure 30. Installation position AAL

Code	The location of the handwheel in relation to the flow direction (seen from valve A side)
AR	R Location of the handwheel on the right side
AL	L Location of the handwheel on the left side
Actuator installation positions: <b>ball valve / manual gear, ball valve / electric actuator</b>	
Ball valve with actuator will be delivered in ABR position as a standard. Please inform us, whether you want to have another option when placing an order.	

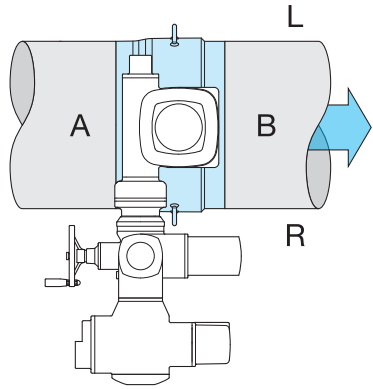

Figure 31. Installation position ARA

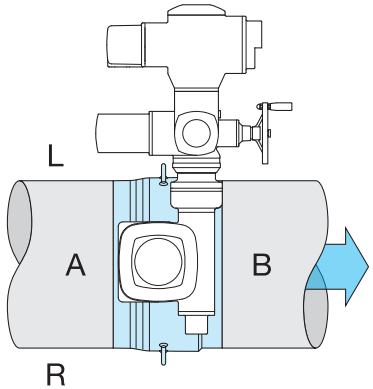

Figure 32. Installation position ALB

## 6. Maintenance

Vexve Oy's ball valves are virtually maintenance-free.

Correct choice of valve as well as careful installation, commissioning, and use significantly reduce any need for maintenance.



**WARNING:**

When the valve is installed in the line, its surface temperature may be dangerously high. Protect yourself against burns.

We recommend checking the following periodically:

Check that the valve is free from surface damage and shaft leaks, and carefully repair any damage.

To ensure long-term operational reliability, even when seldom used (around ten times a year or less), we recommend the following:

Approximately six months after commissioning and then once a year, inspect the valve for shaft leaks, check the manual gear / actuator, and ensure the tightness of the screws between valves.

### 6.1 Replacing the O-ring seal of stem in valves DN 65–150 manufactured 2015 or later

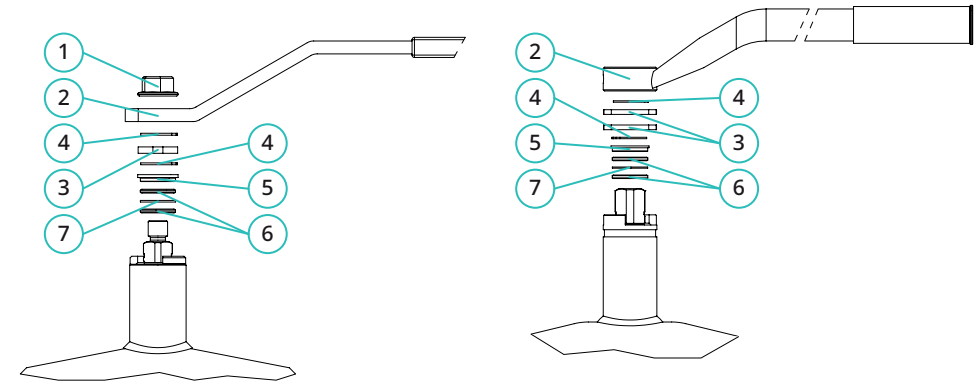

DN 65-100

DN 125-150

- remove the hex nut (1) (DN 65-100)
- remove the handle (2)
- remove the retaining ring (4)
- remove the block stop (3)
- remove the bush (5)
- remove the upper o-ring (6), the distance plate (7) and the lower o-ring (6)
- put the new lower o-ring (6), the distance plate (7) and the new upper o-ring (6) in their places. Install the o-rings by pressing them evenly downwards from the upper edge
- assemble the rest of the removed parts in reverse order

	Part	DN 65	DN 80	DN 100	DN 125	DN 150
1	Nut	288570	288570	288570	-	-
2	Handle	28853550	28853550	28853750	288540	288541
3	Block stop	298196	298196	298198	298200	298200
4	Retaining ring*	299419	299419	299421	299422	299422
5	Bush*	29943740	29943740	299439	299450	299450
6	O-ring*	298268	298268	288285	288270	288270
7	Distance plate*	299327	299327	299329	299330	299330

\*included in replacement sets VA04, VA05 & VA06

## 6.2 Replacing the O-ring seal of stem in valves with actuators

DN 65–150 manufactured 2015 or later

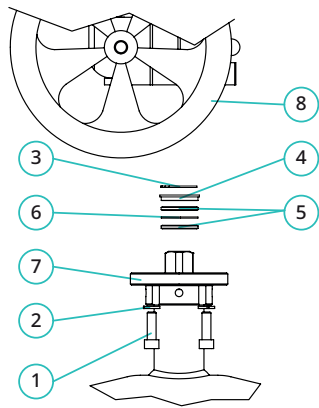

**NOTE:**

Clean the stem hole of the actuator before reinstalling the actuator. Actuator must fit the stem easily so that it won't press the stem downwards.

- remove the hex screws (1), the washers (2), the actuator (8), the retaining ring (3) and the bush (4)
- remove the upper o-ring (5), the distance plate (6) and the lower o-ring (5)
- put the new lower o-ring (5), the distance plate (6) and the new upper o-ring (5) in their places. Install the o-rings by pressing them evenly downwards from the upper edge
- assemble the rest of the removed parts in reverse order

Part	DN 125	DN 150
1 Hex screw	288961	288961
2 Washer	289453	289453
3 Retaining ring*	299422	299422
4 Bush*	299450	299450
5 O-ring*	288270	288270
6 Distance plate*	299330	299330
7 Flange	298827	298827
8 Actuator	x	x

\*included in replacement sets VA04, VA05 & VA06

## 6.3 Replacing the O-ring seal of stem in valves DN 200–300

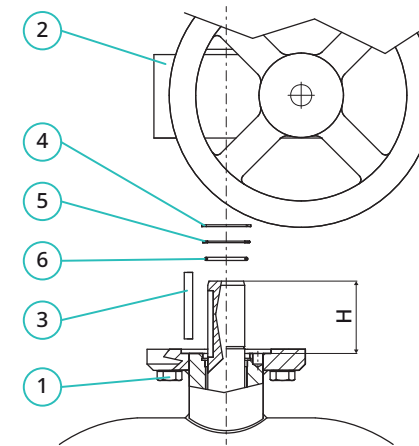

**NOTE:**

When reassembling, be sure to put the retaining ring (4) properly into its groove in the stem and make sure that the stem is in the right position >> Check the height H from the table below.

Make sure that the gap in the retaining ring (4) is not located in the same place with the key (3). Clean the stem hole of the actuator before reinstalling the actuator (2). Actuator must fit the stem easily so that it won't press the stem downwards.

- remove the hex screws (1) and the actuator (2)
- remove the key (3), the retaining ring (4) and the top distance plate (5)
- remove the damaged o-ring (6)
- put the new o-ring (6) in its place by pressing it evenly downwards from its upper edge
- assemble the rest of the removed parts in reverse order

Part	DN 200	DN 250	DN 300
1 Hex screw	001031	001032	981166
2 Actuator	x	x	x
3 Key*	040002	040001	040005
4 Retaining ring*	008010	009006	009008
5 Top distance plate*	940068	940037	940164
6 O-ring*	010017	010018	010024**
H Height [mm]	68	84	94

\*included in replacement sets VA07, VA08 & VA09

\*\* manufactured 2025 or later

## 6.4 Replacing the O-ring seal of stem in valves DN 350–500



### NOTE:

When reassembling, be sure to put the retaining ring (4) properly into its groove in the stem and make sure that the stem is in the right position >> Check the height H from the table below.

Make sure that the gap in the retaining ring (4) is not located in the same place with the key (3).

Clean the stem hole of the actuator before installing the actuator (2). Actuator must fit the stem easily so that it won't press the stem downwards.

- remove the hex screws (1) and the actuator (2)
- remove the key (3) and the retaining ring (4)
- remove the bush (5). See the following instructions for different valve sizes:
  - DN 350–500: Simply remove the top distance plate/sealing bush (5)
- remove the upper o-ring, the distance plate (7) and the lower o-ring
- put the new lower o-ring (6), distance plate (7) and the new upper o-ring (6) in their places. Install the o-rings by pressing them evenly downwards from the upper edge
- assemble the rest of the removed parts in reverse order

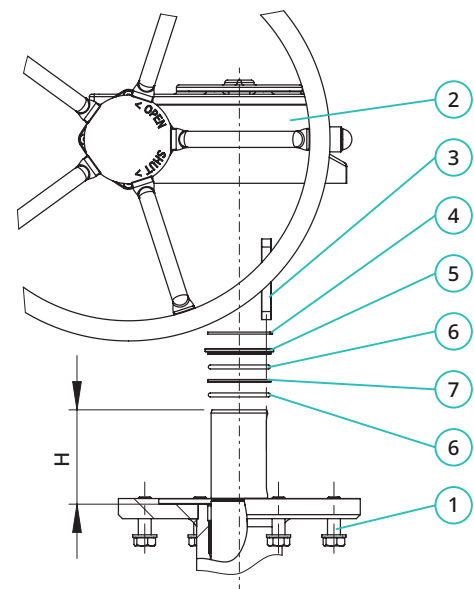

DN 350–500

	Part	DN 350	DN 400	DN 500
1	Hex screw	981166	981167	981171
2	Actuator	x	x	x
3	Key*	070005	070006	070007
4	Retaining ring*	009008	070014	070015
5	Top distance plate/Sealing bush*	940164	970038	970039
5.1	Hex socket screw	-	-	-
6	O-ring*	010024**	070002	070003
7	Distance plate*	940163	970058	970059
H	Height [mm]	86	117	121
A	Screw (M12) for removing the bush	-	-	-

\*included in replacement sets VA10, VA11 & VA12

\*\* manufactured 2025 or later

# 7. Appendices

## 7.1 Parts list for steel ball valves < DN 200

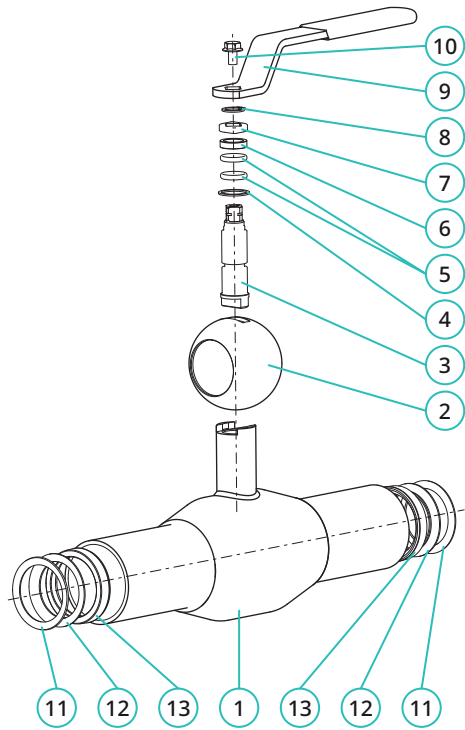

Part Number		qty
1	Valve body	1
2	Ball	1
3	Stem	1
4	Sliding plate	1
5	O-ring	2
6	Bush	1
7	Block stop	1
8	Retaining ring	1
9	Handle	1
10	Hex flange bolt	1
11	Spring plate	2
12	Support plate	2
13	Ball seal	2

## 7.2 Parts list for steel ball valves ≥ DN 200

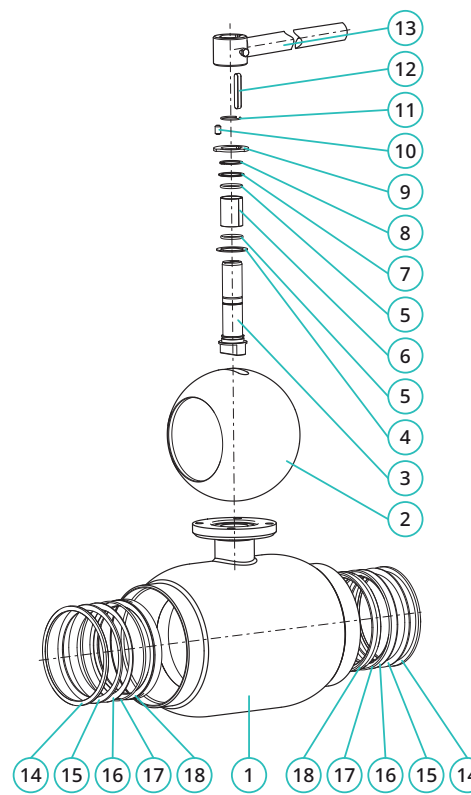

Part Number		qty
1	Valve body	1
2	Shell ball	1
3	Stem	1
4	Sliding plate	1
5	O-ring	2
6	Sliding bearing	1
7	Top distance plate	1
8	Retaining ring	1
9	Block stop	1
10	Dowel pin	1
11	Retaining ring	1
12	Key	1
13	Handle	1
14	Retaining ring	2
15	Spring plate	2
16	Support plate	2
17	O-ring	2
18	Ball seal	2

### 7.3 Coupling dimensions, reduced bore ball valves DN 65–500 with actuators

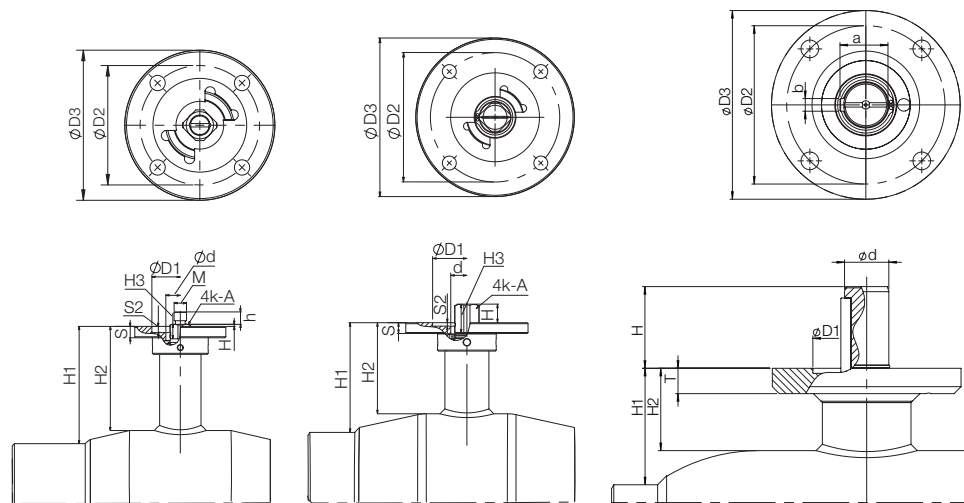

DN 65–100

DN 125–150

DN 200–500

DN	H	h	S/T	S2	A	M	Ød	H1	H2	H3	a	b	D1	D2	D3	Bolts	Key	Flange ISO5211
65	5.5	13	11	2	14	M12	25.5	69	56	11			55	70	88	4xM8		F07
80	5.5	13	11	2	14	M12	25.5	75	59	11			55	70	88	4xM8		F07
100	2	12	11	6	16	M12	28	114	99	14			55	70	88	4xM8		F07
125	19		11	4	20		33	112	93	29			70	102	125	4xM10		F10
150	19		11	4	20		33	118	93	29			70	102	125	4xM10		F10
Toler.					-0.1													

200	65		20				35	92	65		38	10	85	125	149	4xM12	A-10x8 - 63	F12
250	79		20				40	108	67		43	12	100	140	179	4xM16	A-12x8 - 80	F14
300	88		20				50	133	67		53.5	14	130	165	209	4xM20	A-14x9 - 90	F16
350	80		20				50	192	116		53.5	14	130	165	209	4xM20	A-14x9 - 80	F16
400	110		25				70	242	141		74.5	20	200	254	300	8xM16	A-20x12 - 100	F25
500	115		40				90	259	183		95	25	230	298	350	8xM20	A-25x14 - 100	F30
Toler.							-0.1											

### 7.4 Coupling dimensions, full bore ball valves DN 50–400 with actuators

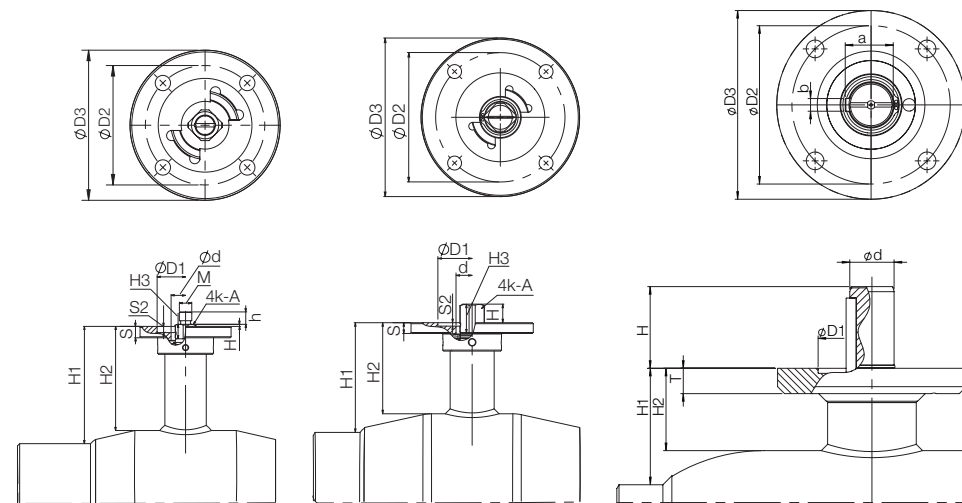

DN 50–80

DN 100–125

DN 150–400

DN	H	h	S/T	S2	A	M	Ød	H1	H2	H3	a	b	D1	D2	D3	Bolts	Key	Flange ISO5211
50	5.5	13	11	2	14	M12	25.5	76	56	11			55	70	88	4xM8		F07
65	5.5	13	11	2	14	M12	25.5	81	59	11			55	70	88	4xM8		F07
80	2	12	11	6	16	M12	28	127	99	14			55	70	88	4xM8		F07
100	19		11	4	20		33	125	93	29			70	102	125	4xM10		F10
125	19		11	4	20		33	132	93	29			70	102	125	4xM10		F10
Toler.					-0.1													

150	65		20				35	117	65		38	10	85	125	149	4xM12	A-10x8 - 63	F12
200	79		20				40	135	67		43	12	100	140	179	4xM16	A-12x8 - 80	F14
250	88		20				50	148	75		53.5	14	130	165	209	4xM20	A-14x9 - 90	F16
300	80		20				50	208	116		53.5	14	130	165	209	4xM20	A-14x9 - 80	F16
350	110		25				70	267	141		74.5	20	200	254	300	8xM16	A-20x12 - 100	F25
400	115		40				90	309	183		95	25	230	298	350	8xM20	A-25x14 - 100	F30
Toler.							-0.1											

## 7.5 Maximum allowed operating torques

DN-size <sup>1)</sup>		Torque <sup>2)</sup> [Nm]				Max. pressure class <sup>3)</sup>
Reduced bore	Full bore					
DN 65	DN 50	60	63	68	75	PN 25
DN 80	DN 65	80	85	98	110	
DN 100	DN 80	110	125	150	250	
DN 125	DN 100	150	200	270	390	
DN 150	DN 125	280	350	520	750	
DN 200	DN 150	300	600	900	1200	
DN 250	DN 200	800	1300	1900	2500	
DN 300	DN 250	2000	2500	3000	4000	
DN 350	DN 300	1000	2200	2800	4000	
DN 400	DN 350	1500	3000	4500	6500	
DN 500	DN 400	2000	6000	9000	12000	
		0	10	16	25	
		Pressure difference <sup>4)</sup> [bar]				

1) DN-size of the valve

2) Max. torque needed to open/close the valve

3) Max. pressure class of the valve available

4) Pressure difference across the valve  $\Delta p$ :

where

$$p = p_1 - p_2,$$

$p_1$  = pressure before the valve

$p_2$  = pressure after the valve

## 7.6 Kv value chart

DN-size	Kv-values	
	Reduced bore	Full bore
50		180
65	182	305
80	315	456
100	470	1474
125	830	2238
150	1150	2417
200	1750	3875
250	3200	5639
300	4600	15400
350	9600	27720
400	13300	34800
500	18700	



**NOTE:**

Kv values for water





**Vexve Oy**

Pajakatu 11  
38200 Sasstamala  
Finland

Riihenkalliontie 10  
23800 Laitila  
Finland

Tel. +358 10 734 0800  
[vexve.customer@vexve.com](mailto:vexve.customer@vexve.com)

