

THE NETHERLANDS
(N E D E R L A N D)**COMMUNICATION**Concerning ⁽¹⁾:

- approval granted
- ~~approval extended~~
- ~~approval refused~~
- ~~approval withdrawn~~
- ~~production definitely discontinued~~

of a type of tyre for motor vehicles pursuant to Regulation number 54.

Approval number: E4*54R00/23*43563*00

1. Manufacturer's name and address : Shandong Longyue Rubber Co.,Ltd.
The South of Yalujiang Road, Wenzhuang Village
Qinghe Agency of Cao County, Heze City,
Shandong Province 274400, China(PRC)
2. Tyre type designation ⁽²⁾
 - 2.1. Brand-name(s)/trademark(s) : See annex 1 of communication form
 - 2.2. Trade description(s)/Commercial name(s) : See annex 1 of communication form
3. If applicable, name and address of the manufacturer's representative : not applicable
4. Summarised description :
 - 4.1. Size of tyre : 225/70R15C; 225/70R15LT
 - 4.2. Category of use : ~~normal~~/snow/~~special~~ ⁽¹⁾
 - 4.3. Structure : ~~diagonal (bias ply)~~/radial ⁽¹⁾
 - 4.4. Tyre class : C2/~~C3~~
 - 4.5. Speed category symbol:
 - 4.5.1 nominal : R
 - 4.5.2 additional (if applicable) : ---
 - 4.6. Load-capacity indices:
 - 4.6.1 Corresponding to nominal speed:
 - single : 112
 - twinned (dual) : 110



4.6.2 Corresponding to additional speed:

- single : ---
- twinned (dual) : ---
- 5. Technical service and, where applicable, test laboratory approved for purposes of approval or of verification of conformity : TÜV NORD Mobilität GmbH & Co. KG
IFM - Institut für Fahrzeugtechnik und Mobilität,
Schönscheidtstr. 28, D-45307 Essen
- 6. Date of report issued by that service : April 28, 2019
- 7. Number of report issued by that service : CS054-A0-2019-00589
- 8. Reason(s) of extension (if applicable) : not applicable
- 9. Any remarks : ---
- 10. Place : Zoetermeer
- 11. Date : 16 May 2019

12. Signature :

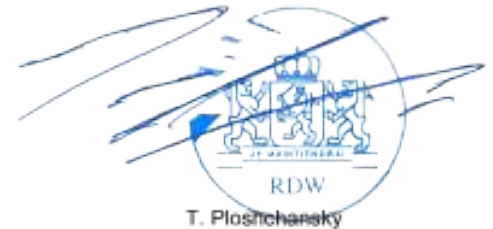

RDW
T. Ploschansky

13. Annexed to this communication is a list of documents in the approval file deposited at the administrative service having delivered the approval and which can be obtained upon request.
- Application form relating to ECE approval for a pneumatic tyre pursuant to Regulation number 54.
 - The drawing of the tyre's sidewalls, tread and dimensioned cross-section.
 - The test report as mentioned in item 7.

⁽¹⁾ Strike out what does not apply.

⁽²⁾ A list of Brand name(s)/trademark(s) or Trade description(s)/ Commercial name(s) may be annexed to this communication

Approval number: E4*54R00/23*43563*00

Annex 1

Brand-name(s)/trademark(s):

CONSTANCY; GRENLANDER; ILINK; FRONWAY; SAILWIN; ARIVO; XBRI; LUXXAN;
RHINO; TTYRE; CRYSTAL; ROCKBLADE; ROADMARCH

Trade description(s)/Commercial name(s)

Winter GL989; Winter IL989; ICEPOWER 989; ICEWINNER 989; WINMASTER ARW6; INSPIRER
W22; THIRTY; ROCK 989S; SNOWROVER 989; GREENTOUR A/S; MULTIMILE A/S;
FRONTOUR A/S; FREIMILE A/S; Vanderful A/S; INSPIRER A/S 2; FORTY; ROCK A/S TWO;
VAN A/S



APPLICATION FOR APPROVAL OF A TYPE OF PNEUMATIC TYRE ACCORDING TO ECE REGULATION No. 54, 00 SERIES OF AMENDMENTS

- | | | | |
|--------|---|---|---|
| 1. | The Brand name(s) or trademark(s) ⁽²⁾ | : | CONSTANCY; GRENLANDER; ILINK; FRONWAY; SAILWIN; ARIVO;XBRI; LUXXAN; RHINO; T TYRE; CRYSTAL; ROCKBLADE; ROADMARCH; |
| 2. | Trade description(s) or Commercial name(s) ⁽²⁾ | : | Winter GL989;Winter IL989;ICEPOWER 989; ICEWINNER 989;WINMASTER ARW6; INSPIRER W22;THIRTY;ROCK 989S; SNOWROVER 989; GREENTOUR A/S; MULTIMILE A/S;FRONTOUR A/S; FREIMILE A/S;Vanderful A/S;INSPIRER A/S 2; FORTY;ROCK A/S TWO;VAN A/S; |
| 3. | Manufacturer's name and address | : | Shandong Longyue Rubber Co., Ltd.
The South of Yalujiang Road, Wenzhuang Village Qinghe
Agency of Cao County, Heze city, Shandong Province,
P.R.China |
| 4. | If applicable, name and address of manufacturer's representative | : | not applicable |
| 5. | Summarised description, | | |
| 5.1. | Tyre size designation | : | 225/70R15C; 225/70R15LT |
| 5.2. | Category of use | : | normal /special/snow ⁽¹⁾ |
| 5.3. | Structure | : | diagonal (bias ply) / radial ⁽¹⁾ |
| 5.4. | Speed category symbol | | |
| 5.4.1. | Nominal | : | R |
| 5.4.2. | Additional (if applicable) | : | not applicable |
| 5.5. | Load capacity indices | | |
| 5.5.1. | corresponding to nominal speed | : | single: 112, twinned (dual): 110 |
| 5.5.2. | corresponding to nominal speed | : | single: ---, twinned (dual): --- |
| 6. | Overall dimensions | : | Calculated/ Annex 5 ⁽¹⁾ |
| | Section width/Measured max Overall SW | : | 228/226.1 |
| | Outer diameter/Measured max outer Diameter | : | 697/693 |
| 7. | Factor 'x' | : | 0.70 |
| 8. | Ply-rating number for diagonal (bias ply) tyres | : | 8 PR |
| 9. | Rims on which the tyre can be mounted | : | 6 1/2J |
| 10. | Measuring rim and test rim | : | see attached test report |
| 11. | Tyre class | : | C2 / C3 ⁽¹⁾ |
| 12. | State whether the tyre is | : | tube less / tube type ⁽¹⁾ |
| 13. | Traction tyre | : | Yes / no (see the tread pattern detail in drawing) ⁽¹⁾ |
| 14. | State if special use tyre | : | Yes / no ⁽¹⁾ (with M+S inscription) |
| | Professional Off-Road | : | Yes / no ⁽¹⁾ |
| | Tread depth / Void to fill ratio | : | n.a. |
| 15. | The inflation pressure for the dimension measurement and for the load/speed endurance test pressure | : | 65 PSI (also see attached test report) |
| 16. | Submitted for approval on (date) | : | 15 April 2019 |

We herewith declare that we have not applied and will not apply for approval with another Contracting Party of the ECE for the same type of product.



(1) Strike out what does not apply.

(2) Modified points are underlined for extension.

MANUFACTURER'S STAMP

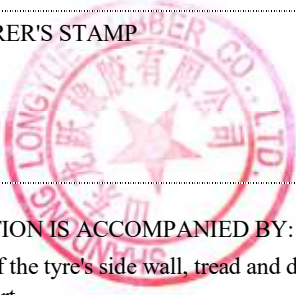

Signature : 

Name: Li Kuiguan

THIS APPLICATION IS ACCOMPANIED BY:

- A drawing of the tyre's side wall, tread and dimensioned cross section.
- The test report.

(1) Strike out what does not apply.
(2) Modified points are underlined for extension.



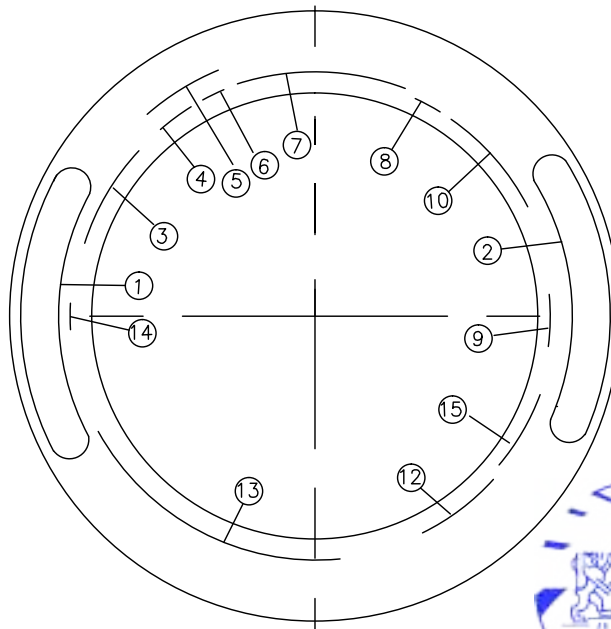
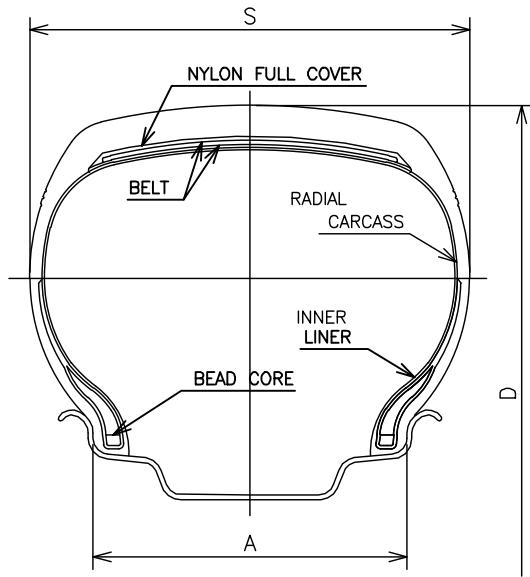

UPPER

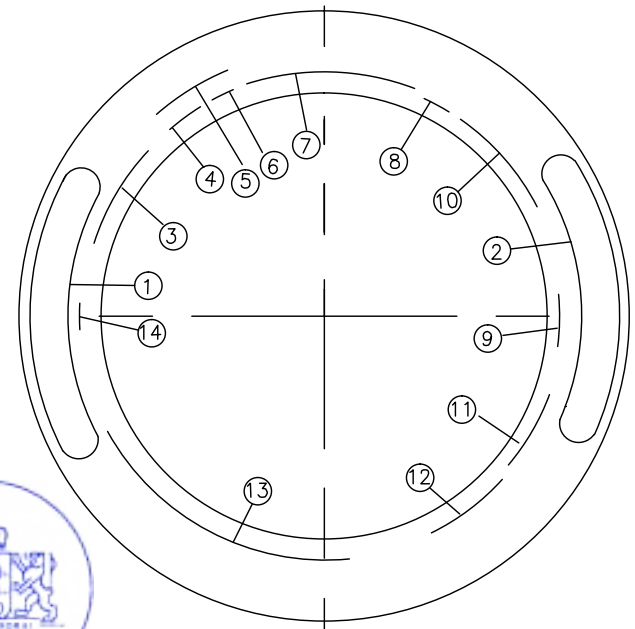

LOWER

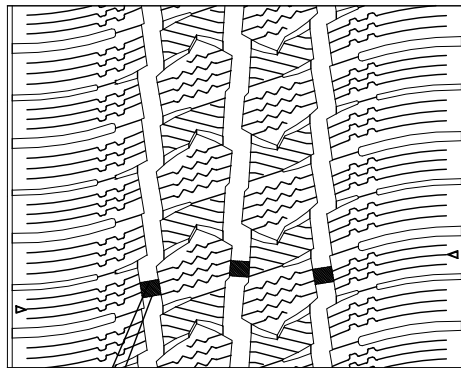

6 TREAD WEAR INDICATORS EQUALLY SPACED

1	CONSTANCY; GRENLANDER; I LINK; FRONWAY; SAILWIN; ARIVO;XBRI; LUXXAN; RHINO; T TYRE; CRYSTAL; ROCKBLADE; ROADMARCH;	8	M+S
		9	MADE IN CHINA
2	Winter GL989; Winter IL989; ICEPOWER 989; ICEWINNER 989; WINMASTER ARW6; INSPIRER W22; THIRTY; ROCK 989S; SNOWROVER 989;	10	LOAD RANGE D MAX. LOAD SINGLE 1120 kg (2469 LBS) AT 450 kPa (65 PSI) MAX.PRESS. MAX. LOAD DUAL 1060 kg (2337 LBS) AT 450 kPa (65 PSI) MAX.PRESS.
3	PLIES:TREAD 2 POLYESTER+2 STEEL+1 NYLON SIDEWALL 2 POLYESTER	11	DOT 17B KMDNCBXXXX (DATE CODE)
		12	ECE APPROVAL MARK
4	RIM: 6 1/2J	13	SAFETY WARNING
5	RADIAL TUBELESS	14	
6	MOLD No.	15	DOT 17B KMDNCB
7	225/70R15C 112/110R 8PR or 225/70R15LT 112/110R 8PR		

TIRE SIZE	D(mm)	S(mm)	A(mm)	LOAD INDEX SPEED CODE	REMARK
225/70R15C or 225/70R15LT	697	228	165	112/110R	_____

SCALE : FREE	DATE : 2019.04.15	DESIGNED BY	CHECKED BY	APPROVED BY	DRAWING NO.	
SHANDONG LONGYUE RUBBER CO. LTD.		Zhao Yang	Xie Baoshan	Shen Maoqiao	TITLE	225/70R15C 112/110R 8PR or 225/70R15LT 112/110R 8PR

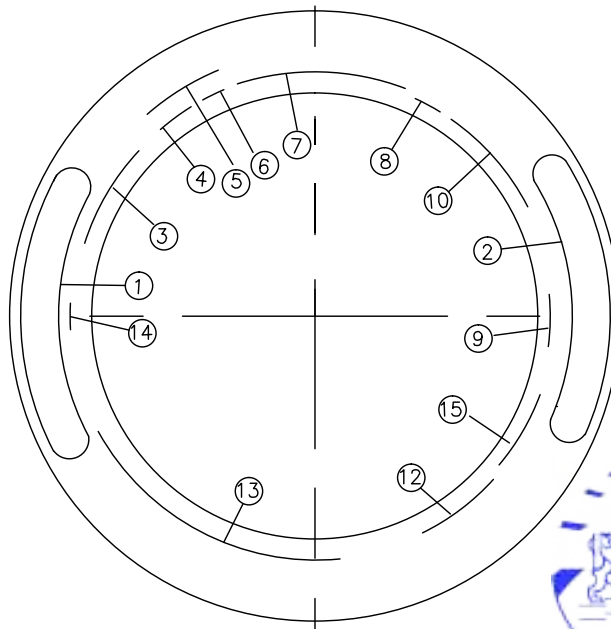
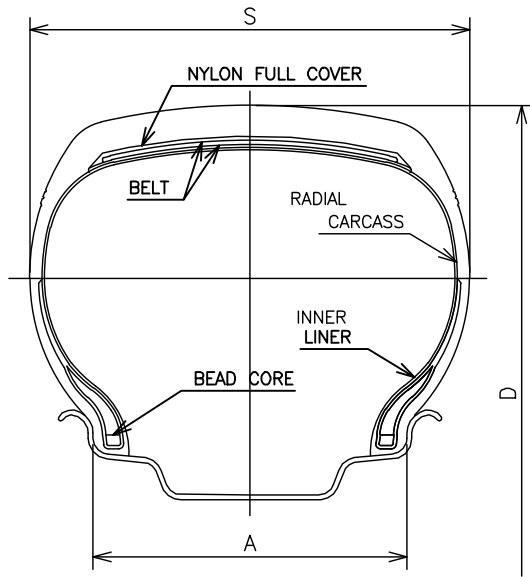

UPPER

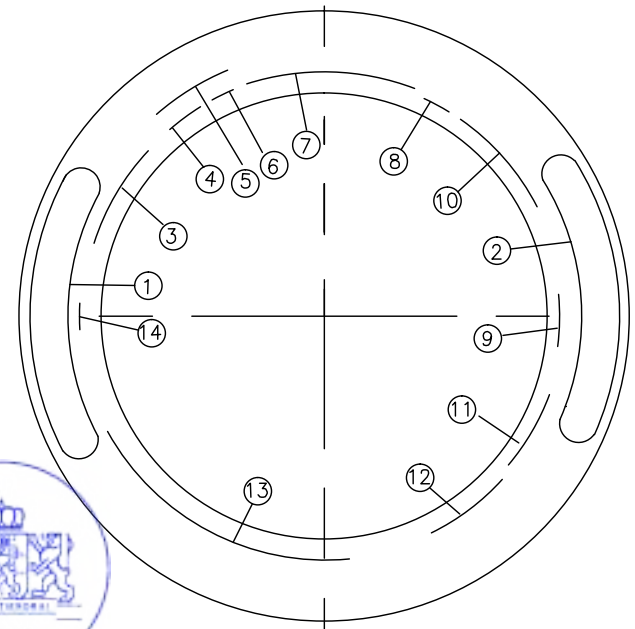

LOWER

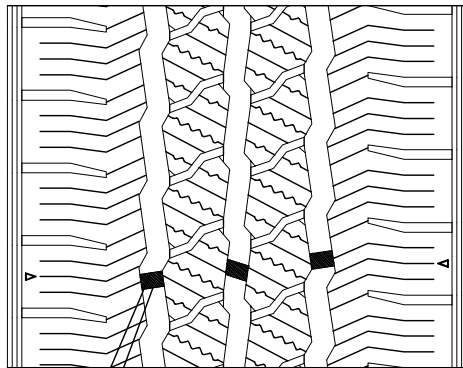

6 TREAD WEAR INDICATORS EQUALLY SPACED

1	CONSTANCY; GRENLANDER; I LINK; FRONWAY; SAILWIN; ARIVO;XBRI; LUXXAN; RHINO; T TYRE; CRYSTAL; ROCKBLADE; ROADMARCH;	8	M+S
		9	MADE IN CHINA
2	GREENTOUR A/S; MULTIMILE A/S; FRONTOUR A/S; FREIMILE A/S; Vanderful A/S; INSPIRER A/S 2; FORTY; ROCK A/S TWO; VAN A/S;	10	LOAD RANGE D MAX. LOAD SINGLE 1120 kg (2469 LBS) AT 450 kPa (65 PSI) MAX.PRESS. MAX. LOAD DUAL 1060 kg (2337 LBS) AT 450 kPa (65 PSI) MAX.PRESS.
3	PLIES:TREAD 2 POLYESTER+2 STEEL+1 NYLON SIDEWALL 2 POLYESTER	11	DOT 17B KMDRLB XXXX (DATE CODE)
		12	ECE APPROVAL MARK
4	RIM: 6 1/2J	13	SAFETY WARNING
5	RADIAL TUBELESS	14	ALL SEASONS
6	MOLD No.	15	DOT 17B KMDRLB
7	225/70R15C 112/110R 8PR or 225/70R15LT 112/110R 8PR		

TIRE SIZE	D(mm)	S(mm)	A(mm)	LOAD INDEX SPEED CODE	REMARK
225/70R15C or 225/70R15LT	697	228	165	112/110R	_____

SCALE : FREE	DATE : 2019.04.15	DESIGNED BY	CHECKED BY	APPROVED BY	DRAWING NO.	
SHANDONG LONGYUE RUBBER CO. LTD.		Zhao Yang	Xie Baoshan	Shen Maoqiao	TITLE	225/70R15C 112/110R 8PR or 225/70R15LT 112/110R 8PR

Type : **225/70R15 C 112/110R**
 Manufacturer : **Shandong Longyue Rubber Co.,Ltd.**

Test Report

Agreement concerning the adoption of uniform technical prescriptions for the wheeled vehicles, equipment and parts which can be fitted and/or be used on wheeled vehicles and the conditions for reciprocal recognition of approvals granted on the basis of these prescriptions

Uniform Provisions Concerning The Approval Of Pneumatic Tyres For Motor Vehicles And Their Trailers.

ECE-R 54
 as last amended

Revision 3
 Supplement 23 to the 00 series of amendments

Approval status	
ECE	Number of approval
	E4*54R00/23*43563*00



Type : **225/70R15 C 112/110R**
 Manufacturer : **Shandong Longyue Rubber Co.,Ltd.**

1. Genreal information

- 1.1. Manufacturer's name and address : Shandong Longyue Rubber Co.,Ltd.
 The South of Yalujiang Road, Wenzhuang Village Qinghe Agency of Cao County, Heze City, Shandong Province 274400, China(PRC)
- 1.2. Brand-name(s)/trademark(s) : See annex 1 of communication form
- 1.3. Trade description(s)/Commercial name(s) : See annex 1 of communication form
- 1.4. Size designation : 225/70R15 C
- 1.5. Category of use : snow
- 1.6. Structure : Radial
- 1.6. Speed category : nominal: R supplementary: ---
- 1.7. Load capacity index
 corresponding to nominal speed : single: 112 twinned: 110
 corresponding to supplementary speed : single: --- twinned: ---
- 1.8. Indication : Tubeless
- 1.9. Test object received : ---
- 1.10. Test location : Shandong Longyue Rubber Co.,Ltd.
 The South of Yalujiang Road, Wenzhuang Village Qinghe Agency of Cao County, Heze City, Shandong Province 274400, China(PRC)
- 1.11. Test date : March 10, 2019
- 1.12. Remarks concerning tested object(s) : The results of the test refer exclusively to the object(s) mentioned under item 1.4. of this report.

2. Markings

- 2.1. Brand-name/trademark : CONSTANCY
- 2.2. Trade description/Commercial name : Winter GL989
- 2.3. Size designation : 225/70R15 C
- 2.4. Category of use : snow
- 2.5. Structure : Radial
- 2.6. Plies
 Steel : 0
 POLYESTER : 2
 NYLON : 0



Side wall	Tread
0	2
2	2
0	1



Type : **225/70R15 C 112/110R**
 Manufacturer : **Shandong Longyue Rubber Co.,Ltd.**

4.9. Outer diameter : 693 mm
 4.10. Inflation pressure : 450 kPa
 4.11. Corresponding load 90% : 1008 kg

Step	Step-Duration [h]	Total Duration [h]	Actual speed (km/h)
1	10	10	150
2	10	20	150
3	10	30	160
4	30	60	170

4.11. Conditioning after testing at test-room temperature : more than 6 hours
 4.12. Inflation pressure : 450 kPa
 4.13. Circumference after conditioning, after testing : 2186 mm
 4.14. Outer diameter : 695.8 mm
 4.15. Difference outer diameter before and after testing : 2.8 mm
 (max. 3.5 %) : 0.40%

5. Final Conclusion

5.1. Marking : Pass
 5.2. Measurement : Pass
 5.3. Load / Speed performance test : Pass
 Tread separation, ply separation, cord separation,
 chunking or broken cords : Yes-/ No



Type : **225/70R15 C 112/110R**
Manufacturer : **Shandong Longyue Rubber Co.,Ltd.**

6. Statement of conformity

The type described in this test report and the appendices attached are in compliance with the Test Specification mentioned above.

The samples / test vehicles used were representative in terms of the type to be approved.

The Test Report comprises pages 1 to 6.

The Test Report shall be reproduced and published in full only and by the client only. It shall be reproduced partially with the written permission of the Test Laboratory only.

TEST LABORATORY

TÜV NORD Mobilität GmbH & Co. KG
IFM - Institut für Fahrzeugtechnik und Mobilität,
Schönscheidtstr. 28, D-45307 Essen



Designated Technical Service
RDW No. RDWT-04

Shanghai, April 28, 2019



PY/PY
B.S.M.E Patrick Yu



Type : **225/70R15 C 112/110R**
Manufacturer : **Shandong Longyue Rubber Co.,Ltd.**

List of modifications

Appendix 1

More details for application of : **Date** : **April 28, 2019**

Correction of : -

Modification of : -

Addition of : -

Deletion of : -

