



SpolarPV
Easy Invest, More Returns



22.85 %

Module efficiency

590 W

Highest power output



Product warranty



Linear power warranty

SPV590-TM10-144BD

565-590Watt



High Efficiency

Higher power conversion efficiency benefited from advanced SpolarPV technology.



Anti-reflection

Less than 20% reflectivity with minimum glare.



Good Mechanical Load Performance

Certified to withstand: wind load (2400 Pa), snow load and hail strike(5400 Pa) .



Low Light Performance Resilience

Advanced glass and cell surface texture designs ensure excellent performance in low light environment.



Durability Against Extreme Environmental Conditions

Good performance of Anti-PID & Salt mist certified by 2 PFG 2387/01.18 and IEC61701.

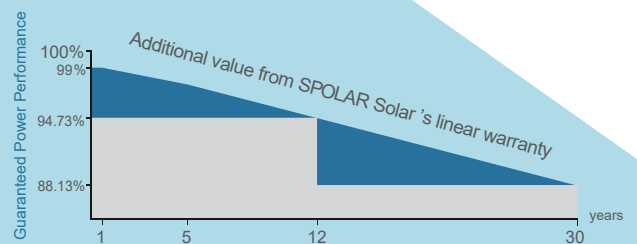

■ Linear performance warranty ■ Standard performance warranty



Electrical Characteristics at Standard Test Conditions (STC)

Module Type	SPV565-TM10-144BD	SPV570-TM10-144BD	SPV575-TM10-144BD	SPV580-TM10-144BD	SPV585-TM10-144BD	SPV590-TM10-144BD
Maximum Power - Pmax (W)	565	570	575	580	585	590
Maximum Power Voltage - Vmp (V)	42.55	42.71	42.87	43.03	43.17	43.38
Maximum Power Current - Imp (A)	13.29	13.35	13.42	13.50	13.55	13.60
Open-circuit Voltage - Voc (V)	50.39	50.55	50.68	50.86	51.02	52.27
Short-circuit Current - Isc (A)	14.20	14.26	14.33	14.40	14.47	14.53
Module Efficiency STC (%)	21.89 %	22.08 %	22.28 %	22.47 %	22.66 %	22.85 %

Electrical Characteristics at Normal Operating Cell Temperature (NOCT)

Module Type	SPV565-TM10-144BD	SPV570-TM10-144BD	SPV575-TM10-144BD	SPV580-TM10-144BD	SPV585-TM10-144BD	SPV590-TM10-144BD
Maximum Power - Pmax (W)	430	434	437	440	444	447
Maximum Power Voltage - Vmp (V)	39.49	39.69	39.79	39.91	40.10	40.22
Maximum Power Current - Imp (A)	10.90	10.95	10.99	11.03	11.07	11.12
Open-circuit Voltage - Voc (V)	47.70	47.80	47.98	48.20	48.43	48.63
Short-circuit Current - Isc (A)	11.46	11.51	11.56	11.59	11.84	11.89
Power Tolerance	0 ~ +3W		Operating Temperature (°C)		-40 °C ~ +85 °C	
Temperature Coefficients of Pmax	-0.30% / °C		Maximum System Voltage		1500 V	
Temperature Coefficients of Voc	-0.275% / °C		Maximum Series Fuse Rating		25 A	
Temperature Coefficients of Isc	0.045% / °C		Nominal Operating Cell Temperature		45 ± 2 °C	

Current-Voltage Curve under different irradiance

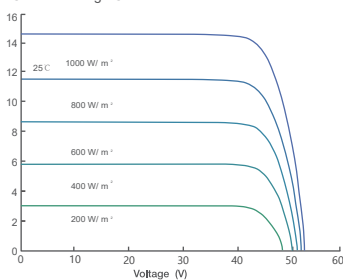

Current-Voltage Curve under different working temperatures

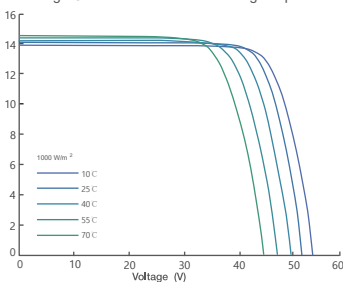

Mechanical Characteristics

Cell Type	Mono-crystalline
No. of Cells	144 (6x24)
Dimensions	2278x1133x30 mm
Weight	32.5 kg
Glass	Dual Glass 2.0mm Heat Strengthened Glass
Frame	Anodized Aluminium Alloy
Junction Box	IP68, MC4 Compatible, 3 Bypass Diode
Output Cables	1x4.0 mm ² , Length: 1200 mm or Customized Length
Packaging Configuration	74pcs/stack, 740pcs/40'HQContainer (Two pallets=One stack)

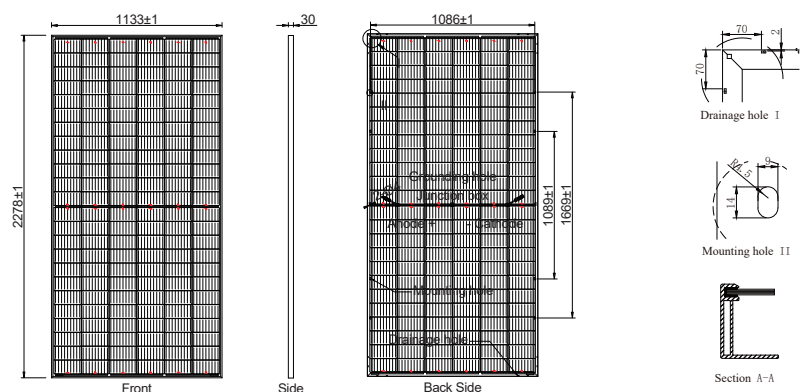

www.spolarpv.com

Zertifikat

Certificate



Zertifikat Nr. *Certificate No.*
PV 50591291

Blatt *Sheet*
0001

Ihr Zeichen *Client Reference*
C.F.

Unser Zeichen *Our Reference*
01-GJJ-CN22LPF5 001

Ausstellungsdatum *Date of Issue*
21.06.2023 (day/mo/yr)

Genehmigungsinhaber *License Holder*
SpolarPV Technology Co., Ltd.
Maoshan Road 39,
Gaochun Economic Development Zone
Nanjing,
211300 Jiangsu
P.R. China

Fertigungsstätte *Manufacturing Plant*
Refer to latest revision
of the annex list of factories

Prüfzeichen *Test Mark*



IEC 61215
IEC 61730
Regular Production
Surveillance

www.tuv.com
ID 1111270997

Geprüft nach *Tested acc. to*

IEC 61215-1:2021
IEC 61215-1-1:2021
IEC 61215-2:2021
IEC 61730-1:2016
IEC 61730-2:2016
EN IEC 61215-1:2021
EN IEC 61215-1-1:2021
EN IEC 61215-2:2021
EN IEC 61730-1:2018
EN IEC 61730-2:2018

Zertifiziertes Produkt (Geräteidentifikation)
Certified Product (Product Identification)

Lizenzentgelte - Einheit
License Fee - Unit

PV Module

Type Designation:

Max. system voltage: up to 1500 VDC (Voc at STC):

With ½ cut of 158 mono c-Si cell:

SPVxxx-PM3-144BD (xxx=390-415, in steps of 5, 144 cells)

SPVxxx-PM3-120BD (xxx=325-345, in steps of 5, 120 cells)

With ½ cut of 166 mono c-Si cell:

SPVxxx-PM6-144BD (xxx=420-460, in steps of 5, 144 cells)

SPVxxx-PM6-132BD (xxx=385-420, in steps of 5, 132 cells)

SPVxxx-PM6-120BD (xxx=350-385, in steps of 5, 120 cells)

SPVxxx-PM6-108BD (xxx=315-345, in steps of 5, 108 cells)

SPVxxx-PM6-96BD (xxx=280-305, in steps of 5, 96 cells)

SPVxxx-PM6-72BD (xxx=210-230, in steps of 5, 72 cells)

With ½ cut of 182 mono c-Si cell:

SPVxxx-PM10-156BD (xxx=565-600, in steps of 5, 156 cells)

SPVxxx-PM10-144BD (xxx=520-555, in steps of 5, 144 cells)

SPVxxx-PM10-132BD (xxx=480-505, in steps of 5, 132 cells)

SPVxxx-PM10-120BD (xxx=435-460, in steps of 5, 120 cells)

SPVxxx-PM10-108BD (xxx=390-415, in steps of 5, 108 cells)

Continued on Page 0002

Dem Zertifikat liegt unsere Prüf- und Zertifizierungsordnung zugrunde.
Das Produkt entspricht den o.g. Anforderungen, die Herstellung wird überwacht.
This certificate is based on our Testing and Certification Regulation. The product
fulfills above mentioned requirements, the production is subject to surveillance.

Zertifizierungsstelle

TÜVRheinland LGA Products GmbH
Dipl.-Ing. (FH) F. He

TÜV Rheinland LGA Products GmbH, Tillystraße 2, 90431 Nürnberg

http://www.tuv.com/safety E-mail: markcheck@tuv.com

Fax: +49 221 806-3935

Zertifikat

Certificate



Zertifikat Nr. *Certificate No.*
PV 50591291

Blatt *Sheet*
0002

Ihr Zeichen *Client Reference*
C.F.

Unser Zeichen *Our Reference*
01-GJJ-CN22LPF5 001

Ausstellungsdatum *Date of Issue*
21.06.2023 (day/mo/yr)

Genehmigungsinhaber *License Holder*
SpolarPV Technology Co., Ltd.
Maoshan Road 39,
Gaochun Economic Development Zone
Nanjing,
211300 Jiangsu
P.R. China

Fertigungsstätte *Manufacturing Plant*
Refer to latest revision
of the annex list of factories

Prüfzeichen *Test Mark*



IEC 61215
IEC 61730
Regular Production
Surveillance

www.tuv.com
ID 1111270997

Geprüft nach *Tested acc. to*

IEC 61215-1:2021
IEC 61215-1-1:2021
IEC 61215-2:2021
IEC 61730-1:2016
IEC 61730-2:2016
EN IEC 61215-1:2021
EN IEC 61215-1-1:2021
EN IEC 61215-2:2021
EN IEC 61730-1:2018
EN IEC 61730-2:2018

Zertifiziertes Produkt (Geräteidentifikation)
Certified Product (Product Identification)

Lizenzentgelte - Einheit
License Fee - Unit

PV Module

Continued on Page 0002

SPVxxx-PM10-96BD (xxx=350-370, in steps of 5, 96 cells)

SPVxxx-PM10-72BD (xxx=260-275, in steps of 5, 72 cells)

With ½ cut of 182 topcan c-Si cell:

SPVxxx-TM10-144BD (xxx=555-585, in steps of 5, 144 cells)

SPVxxx-TM10-120BD (xxx=460-490, in steps of 5, 120 cells)

SPVxxx-TM10-108BD (xxx=410-440, in steps of 5, 108 cells)

With ½ cut of 210 mono c-Si cell:

SPVxxx-PG12-132BD (xxx=640-675, in steps of 5, 132 cells)

SPVxxx-PG12-120BD (xxx=580-610, in steps of 5, 120 cells)

SPVxxx-PG12-110BD (xxx=530-555, in steps of 5, 110 cells)

With ½ cut of 210 mono c-Si cell:

SPVxxx-PG12-T150BD (xxx=480-520, in steps of 5, 150 cells)

SPVxxx-PG12-T120BD (xxx=385-415, in steps of 5, 120 cells)

With ½ cut of 210 topcan c-Si cell:

SPVxxx-TG12-132BD (xxx=660-680, in steps of 5, 132 cells)

SPVxxx-TG12-120BD (xxx=600-620, in steps of 5, 120 cells)

SPVxxx-TG12-110BD (xxx=550-570, in steps of 5, 110 cells)

Continued on Page 0003

Dem Zertifikat liegt unsere Prüf- und Zertifizierungsordnung zugrunde.
Das Produkt entspricht den o.g. Anforderungen, die Herstellung wird überwacht.
This certificate is based on our Testing and Certification Regulation. The product
fulfills above mentioned requirements, the production is subject to surveillance.

TÜV Rheinland LGA Products GmbH, Tillystraße 2, 90431 Nürnberg

http://www.tuv.com/safety E-mail: markcheck@tuv.com

Fax: +49 221 806-3935



Dipl.-Ing. (FH) F. He

Zertifikat

Certificate



Zertifikat Nr. *Certificate No.*
PV 50591291

Blatt *Sheet*
0003

Ihr Zeichen *Client Reference*
C.F.

Unser Zeichen *Our Reference*
01-GJJ-CN22LPF5 001

Ausstellungsdatum *Date of Issue*
21.06.2023 (day/mo/yr)

Genehmigungsinhaber *License Holder*
SpolarPV Technology Co., Ltd.
Maoshan Road 39,
Gaochun Economic Development Zone
Nanjing,
211300 Jiangsu
P.R. China

Fertigungsstätte *Manufacturing Plant*
Refer to latest revision
of the annex list of factories

Prüfzeichen *Test Mark*



Geprüft nach *Tested acc. to*

IEC 61215-1:2021
IEC 61215-1-1:2021
IEC 61215-2:2021
IEC 61730-1:2016
IEC 61730-2:2016
EN IEC 61215-1:2021
EN IEC 61215-1-1:2021
EN IEC 61215-2:2021
EN IEC 61730-1:2018
EN IEC 61730-2:2018

Zertifiziertes Produkt (Geräteidentifikation)
Certified Product (Product Identification)

Lizenzentgelte - Einheit
License Fee - Unit

PV Module

Continued on Page 0003

Remarks:

Class II acc. to IEC 61140
Fire Rating: Class A (according to UL 790)
Design Load/ Safety Factors: 3600 Pa / 1.5 (downward)
1600 Pa / 1.5 (upward)

Conditions:

The product test is voluntarily according to technical regulations. Any change of the design, materials, components or processing may require the repetition of some of the qualification tests in order to retain type approval.

The certificate is valid until 17 March 2027.

Dem Zertifikat liegt unsere Prüf- und Zertifizierungsordnung zugrunde
Das Produkt entspricht den o.g. Anforderungen, die Herstellung wird überwacht
This certificate is based on our Testing and Certification Regulation. The product fulfills above mentioned requirements, the production is subject to surveillance.



Dipl.-Ing. (FH) F. He

TÜV Rheinland LGA Products GmbH, Tillystraße 2, 90431 Nürnberg

http://www.tuv.com/safety E-mail: markcheck@tuv.com

Fax: +49 221 806-3935



QUALITY MANAGEMENT SYSTEM CERTIFICATE

Certification No. 117 23 QU 0029-04 ROS

This is to certify that **SpolarPV Technology Co., Ltd.**

Unified social credit code 91320118MA1WPP4G95

Registered Address **No. 39 Maoshan Road, Gaochun District Economic Development Zone, Nanjing, Jiangsu**

Business Address **502, 5F, Greenland Window Property Management Office, No. 2 Jiangnan Road, Yuhuatai District, Nanjing, Jiangsu**

Has been assessed and registered as meeting the requirements of

GB/T19001-2016/ISO9001:2015

Scope of approval **Sales of photovoltaic module**

First Certification: 06 Apr. 2023

Expiry Date: 05 Apr. 2026

Signed by:



Shanghai Ingeer Certification Assessment Co., Ltd.

Certification and Accreditation Administration of PRC: CNCA-R-2003-117

Tel: 400-633-9001/+86 021-51114700

Web: www.icasiso.com

Add: Room 801, HuaDing Mansion, 2368# West Zhongshan Rd., Xuhui District, Shanghai, China, 200235



Focus on icas WeChat platform



First Surveillance Audit Second Surveillance Audit Third Surveillance Audit

The ownership of the certificate belongs to Shanghai Ingeer Certification Assessment Co., Ltd. The information & validation of this certificate can be checked on the CNCA website: WWW.CNCA.GOV.CN and ICAS website, or by calling ICAS' s clients services Dept. The certificate is only valid when used together with related permits when appropriate. If the organization can't effectively maintain the above management system, ICAS has the right to withdraw the qualification certificate.

LIMITED WARRANTY STATEMENT PHOTOVOLTAIC MODULE PRODUCTS



SpolarPV
Easy Invest, More Returns

SP NO.1905100001

1.Limited Product Warranty - 12 Years Repair, Replacement or Refund Remedy

SpolarPV Technology Co., Ltd (hereafter as “SpolarPV”) warrants to the original buyer (the “Buyer”) that the modules shall be free from defects in materials and workman ship that have an effect on module functionality under normal application, installation, use and service conditions as specified in SpolarPV’s standard product documentation.

SpolarPV guarantees that the module will maintain the mechanical integrity and stability in accordance with approved operation methods described in our installation instructions; the glass of a module will maintain its integrity provided there are no indications of localized impacts or external forces; and that the cable and connector plug of a module will remain safe and operational provided modules are professionally installed. Any damages caused by abrasion, improper installation or animals are exempt from this warranty.

Claims under the warranty can only be accepted if the Buyer can provide proof that the malfunctioning or nonconformity of a module results exclusively from defects in materials and/or workmanship under normal application, installation, use and service conditions specified in SpolarPV’s standard product documentation. Any color change on module or any other changes on module appearance do not represent defects, insofar as the change in appearance does not stem from defects in material and/or workmanship, and does not cause degradation of functionality of the module. If the product fails to conform to this warranty, SpolarPV will, at its option, either repair or replace the product, or provide an appropriate residual market value of the product(s) as compensation.

2.Limited Peak Power Warranty - Limited Remedy

2.1 For double glass poly crystalline and mono crystalline module products, SpolarPV guarantees the first year power degradation is no more than 2% from its nameplate power. From year 2 to year 30, the actual annual power decline will be no more than 0.55%. By the end of year 30, the actual power output will be no less than 82.05 % of the labeled power output.

2.2 The actual power output of the module shall be determined for verification using Standard Testing Conditions only. The actual power output measurement is either carried out by a SpolarPV facility or by a SpolarPV recognized 3rd party testing institute. Testing equipment tolerances will be applied to all actual power output measurements.

2.3 In the event it is determined that there is a negative deviation of actual performance from the warranted values then SpolarPV, at its option, will compensate for such loss in power by either providing to the Buyer additional modules to make up the total wattage loss, or by repairing or replacing the modules or providing an appropriate residual market value of the product(s) as compensation.

LIMITED WARRANTY STATEMENT PHOTOVOLTAIC MODULE PRODUCTS



SpolarPV
Easy Invest, More Returns

SP NO.1905100001

3.Exclusions and Limitations

3.1 Warranty claims must in any event be filed within the applicable warranty period.

3.2 The limited warranties do not apply to any PV modules which, in SpolarPV absolute judgment, have been subjected to:

- Misuse, abuse, neglect or accident;
- Alternation, improper installation or application;
- Non-observance of SpolarPV's installation-users and maintenance instructions;
- Repair or modifications by someone other than a qualified service technician;
- Power failure surges, lighting, flood, fire, accidental breakage or other events outside SpolarPV's control;
- Any move and subsequent installation of the module.

3.3 The limited warranties do not cover any shipping costs for the return of the PV modules, or for reshipment of any repaired or replaced PV modules, or cost associated with installation, removal or reinstallation of the PV modules.

3.4 Warranty claims will not be honored if the type or serial number of the PV modules have been altered, removed or made illegible. All other statements made by SpolarPV (including without limitation to those made in the SpolarPV's promotional materials) in respect of the properties, performance characteristics and other aspects of the modules are for illustration only and are not legally binding on SpolarPV. To the fullest extent permitted by law, SpolarPV excludes all implied representations and warranties in respect of the modules, their properties and performance characteristics. To the fullest extent permitted by law, SpolarPV also excludes all liabilities to the Buyer and any user of the PV modules produced by SpolarPV for any loss of actual or anticipated profits, revenues, turnover, anticipated savings, business or goodwill.

4.Disputes

No action, regardless of form, arising out of or in any way connected with this limited warranty policy, may be brought by the Buyer more than one (1) year after the cause of action has accrued.

5.Various

The repair or replacement of the PV modules or the supply of additional PV modules does not cause the beginning of new warranty terms, nor shall the original terms of this limited warranty be extended. Any replaced PV modules shall become the property of SpolarPV. SpolarPV has the right to deliver another type (different in size, color, shape and /or power) in case SpolarPV discontinues producing the PV-module in question at the time of the claim.



INSTALLATION MANUAL



1. General Information

1.1 Overview

Thanks for choosing SPV SOLAR PV modules. In order to ensure the PV modules are installed correctly, please read the following installation instructions carefully before modules are installed and used. Please remember that these products generate electricity and certain safety measures need to be taken to avoid danger.

Make sure the module array is designed in such a way not to exceed the maximum system voltage of any system component such as connectors or inverters and only use compatible connectors of the same type.

The assembly is to be mounted over a fire resistant roof covering rated for the application. Before mounting the module, please consult your local building department to determine approved roofing materials.

The modules are qualified for Class II: which can be used in systems operating at 50 V DC or >240W.

Where general contact access is anticipated; When the modules are for rooftop application, it is necessary to take the overall fire rating of the finished structure as well as operation and maintenance into account. The roofing PV system shall be installed after being evaluated by construction experts or engineers and with official analysis results for the entire structure. It shall be proved capable of supporting extra system bracked pressure, including PV module weight.

1.2 Warnings



- PV modules generate DC electrical energy when exposed to sunlight or other light sources. Active parts of module such as terminals can result in burns, sparks, and lethalshock.
- Artificially concentrated sunlight shall not be directed on the module or panel.
- Front protective glass is utilized on the module. Broken solar module glass is an electrical safety hazard (may cause electric shock or fire). These modules cannot be repaired and should be replaced immediately.
- To reduce the risk of electrical shocks or burns, modules may be covered with an opaque material during installation to avoid injury.
- The installation work of the PV array can only be done under the protection of sun-sheltering covers or sunshades and only qualified person can install or perform maintenance work on this module.
- Follow the battery manufacture's recommendations if batteries are used with modules.
- Do not use this module to replace or partly replace roofs and walls of livingbuildings.
- Do not install modules where flammable gas may be present.
- Do not remove any part installed by SPV Solar or disassemble themodule.

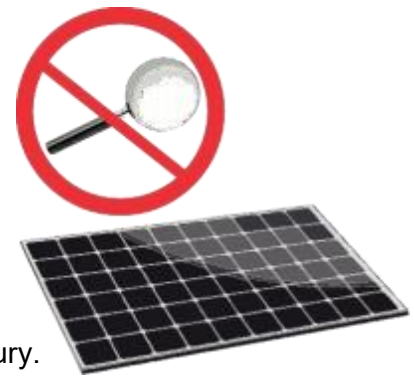

- All instructions should be read and understood before attempting to install, wire, operate and maintain the module.
- Don't lift up PV modules using the attached cables or the junction box.
- Do not touch live terminals with bare hands. Use insulated tools for electrical connections.

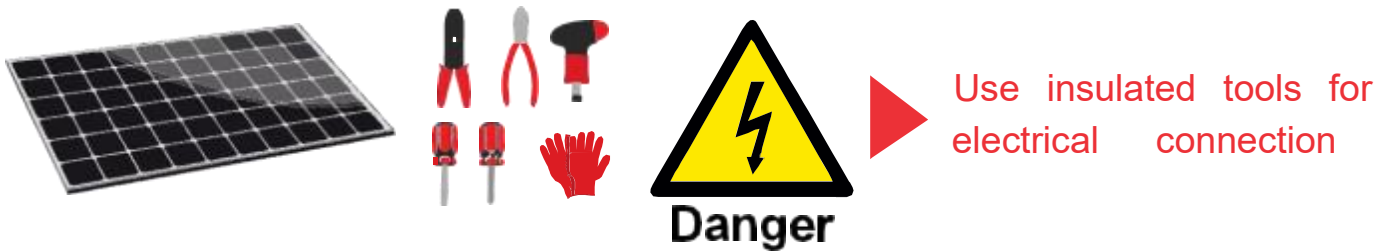

- All PV systems must be grounded to earth. If there is no special regulation, please follow the National Electrical Code or other national code.
- Under normal conditions, a photovoltaic module is likely to experience conditions that produce more current and/or voltage than reported at standard test conditions. Accordingly, the value of I_{sc} and V_{oc} marked on the module should be multiplied by 1.25 when determining PV system component voltage ratings, conductor current ratings, fuse sizes, and size of controls connected to the PV output.
- Once the PV module has been shipped to the installation site, all of the parts should be unpacked properly with care.
- Only the modules with the same type and the capacity should be connected in series inside the string.
- During transporting modules, please attempt to minimize shock or vibration to the module, as this may damage the module or lead to cell micro cracks.
- During all transportation situations, never drop the module from a vehicle, house or hands. This will damage module.
- Do not clean the glass with chemicals. Only use tap water. Make sure the module surface temperature is cool to the touch. Cleaning modules with cool water when module surface temp is high may result in glass breakage.
- Do not stand or step on the PV module like below pictures show. This is prohibited and there is a risk of damage to the module and cause injury for you.



- Do not disconnect modules from the circuit, when they are operating in the system and deriving electrical load.
- When looking at PV modules with anti-reflection (AR) coating technology, it will be normal to see some cells with a slight color difference at different angles. Modules with LRF (light reflective film) and without LRF should not be built in the same array or roof.
- Connector of junction box cannot be contacted with oily substances, for example, lubricant, rust inhibitor etc.
- The maximum altitude the PV module is designed for $\leq 2000\text{m}$.
- Do not carry a module on your head, with the backsheet facing towards to your helmet, if it is not avoidable, please make sure that, the module is facing with the glass side to your helmet.
- The maximum irradiance is $1300\text{W}/\text{m}^2$ for module with transparent and white backsheet rear.
- Meaning of crossed –out wheeled dustbin:
Do not dispose of electrical appliances as unsorted municipal waste, use separate collection facilities.
Contact your local government for information regarding the collection systems available.
If electrical appliances are disposed of in landfills or dumps, hazardous substances can leak into the groundwater and get into the foodchain, damaging your health and well-being.
When replacing old appliances with new ones, the retailer is legally obligated to take back your old appliance for disposals at least free of charge.

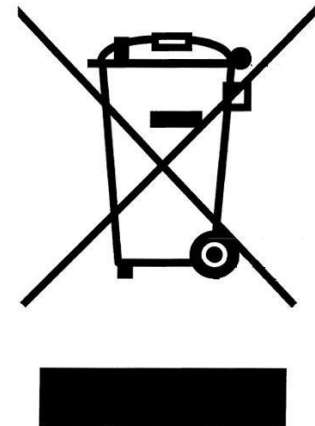

2. Installation

2.1 Installation Safety

- Always wear protective head gear, insulating gloves and safety shoes (with rubber soles).
- Keep the PV module packed in the carton until installation.
- Do not touch the PV module unnecessarily during installation. The glass surface and the frame may be hot. There is a risk of burns and electric shock.
- Do not work in rain, snow or windy conditions.
- Due to the risk of electrical shock, do not perform any work if the terminals of the PV module are wet.
- Use insulated tools and do not use wet tools.
- When installing PV modules, do not drop any objects (e.g., PV modules or tools).
- Make sure flammable gasses are not generated or present near the installationsite.
- Insert module connectors fully and correctly. An audible "click" sound should be heard. This sounds confirms the connectors are fully seated. Check all connections.
- The module leads should be securely fastened to the module frame, Wire Management should be

done in a way to avoid the connector from scratching or impacting the back sheet of the module.

- Do not touch the junction box and the end of the interconnect cables (connectors) with bare hands during installation or under sunlight, regardless if the PV module is connected to or disconnected from the system.
- Do not expose the PV module to excessive loads on the surface of the PV module or twist the frame.
- Do not hit or put excessive load on the glass or back sheet, this may break the cells or cause micro cracks.
- During the installation or operation, don't use sharp tools to wipe the back sheet and glass. Scratches can appear on the module.
- Do not drill holes in the frame. It may cause corrosion of the frame.
- When installing modules on roof mounted structures, please try to follow the "from top to bottom" and/or "from left to right" principle, and don't step on the module. This will damage the module and would be dangerous for personal safety fire tested according ANSI-UL-790:2004.

2.2 Installation Condition

2.2.1 Climate Condition

Please install the modules in the following conditions:

- a) Operating temperature: within -40°C (-40°F) to 85°C (185°F)
- b) Humidity: $< 85\text{RH}\%$

* Note: The mechanical load bearing (include wind and snow loads) of the module is based on the approved mounting methods. The professional system installer must be responsible for mechanical load calculation according to the system design.

2.2.2 Site Selection

In most applications, SPV Solar PV modules should be installed in a location where they will receive maximum sunlight throughout the year. In the Northern Hemisphere, the module should typically face south, and in the Southern Hemisphere, the modules should typically face north. Modules facing 30 degrees away from true South (or North) will lose approximately 10 to 15 percent of their power output. If the module faces 60 degrees away from true South (or North), the power loss will be 20 to 30 percent. When choosing a site, avoid trees, buildings or obstructions, which could cast shadows on the solar photovoltaic modules especially during the winter months when the arc of the sun is lowest over the horizon. Shading causes loss of output, even though the factory fitted bypass diodes of the PV module will minimize any such loss.

Do not install the PV module near open flame or flammable materials.

When solar modules are used to charge batteries, the battery must be installed in a manner, which will protect the performance of the system and the safety of its users. Follow the battery manufacturer's

guidelines concerning installation, operation and maintenance recommendations. In general, the battery (or battery bank) should be away from the main flow of people and animal traffic. Select a battery site that is protected from sunlight, rain, snow, debris, and is well ventilated. Most batteries generate hydrogen gas when charging, which can be explosive. Do not light matches or create sparks near the battery bank. When a battery is installed outdoors, it should be placed in an insulated and ventilated battery case specifically designed for the purpose.

Do not install the PV module in a location where it would be immersed in water or continually exposed to water from a sprinkler or fountain etc.

2.2.3 Tilt Angle Selection

The tilt angle of the PV module is measured between the surface of the PV module and a horizontal ground surface (Figure 1). The PV module generates maximum output power when it faces the sun directly.

For standalone systems with batteries where the PV modules are attached to a permanent structure, the tilt angle of the PV modules should be selected to optimize the performance based on seasonal load and sunlight. In general, if the PV output is adequate when irradiance is low (e.g., winter), then the angle chosen should be adequate during the rest of the year. For grid-connected installations where the PV modules are attached to a permanent structure, PV modules should be tilted so that the energy production from the PV modules will be maximized on an annual basis.

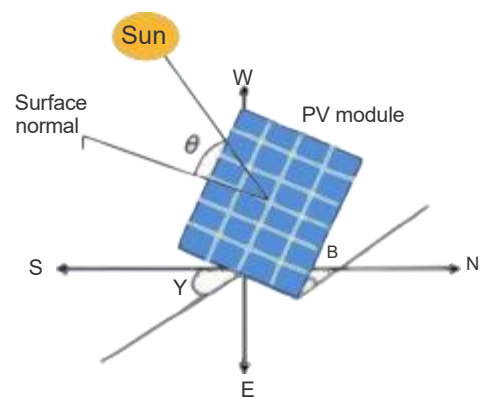

2.3 Mechanical Installation Introduction

Solar PV modules usually can be mounted by using the following methods: bolts and clamps.

Note:

- 1) All installation methods herein are only for reference, and SPV solar will not provide related mounting components, the system installer or trained professional personnel must be responsible for the PV system's design, installation, and mechanical load calculation and security of the system.
- 2) Before installation, the following items should be addressed:
 - a) Visually check the module for any damage. Clean the module if any dirt or residue remains from shipping.
 - b) Check if module serial number stickers match.
- 3) SPV Solar modules are designed to meet a maximum positive (or downward) pressure of 3600Pa (Only



referring to the mentioned module type in this manual) and negative (or upward) pressure of 1600Pa. This design load was then tested with a safety factor of 1.5 times. SPV Solar modules are tested under a maximum downward pressure of 5400Pa and upward pressure of 2400Pa. When mounting modules in snow-prone or high-wind environments, special care should be taken to mount the modules in a manner that provides sufficient design strength while meeting local code requirements.

Please take in note, that the limitation of Tilt angle / slope is maximum 60 °. According to IEC61215, solar modules are rated as a class C Flame-Spread Ratings product according to NSF/ANSI342standards



2.3.1 Mounting with clamps

The module clamps should not come into contact with the front glass and must not deform the frame. Be sure to avoid shadowing effects from the module clamps. The module frame is not to be modified under any circumstances. When choosing this type of clamp-mounting method, please be sure to use at least four clamps on each module, two clamps should be attached on each long sides of the module. Depending on the local wind and snow loads, if excessive pressure load is expected, additional clamps or support would be required to ensure the module can bear the load. The applied torque value should be big enough to fix the modules steadily (Please consult with the clamp or support's supplier for the specific torque value). Please find detailed mounting information in the below illustration, the mounting place distance is suggested bigger than J and less than K. The installation diagram of clamp is shown in figure 5.

Note: The Movement of the mounting rail and the clamps center line are recommended to be within the black arrow area.

The min length of clamps is 50mm.

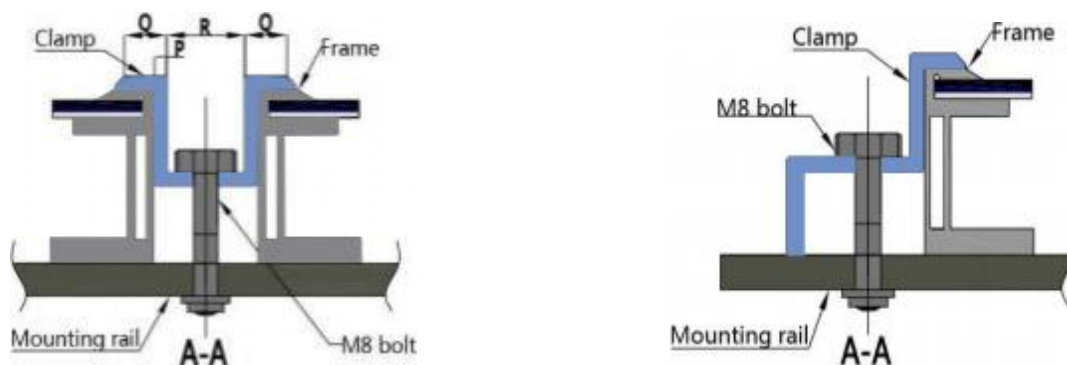

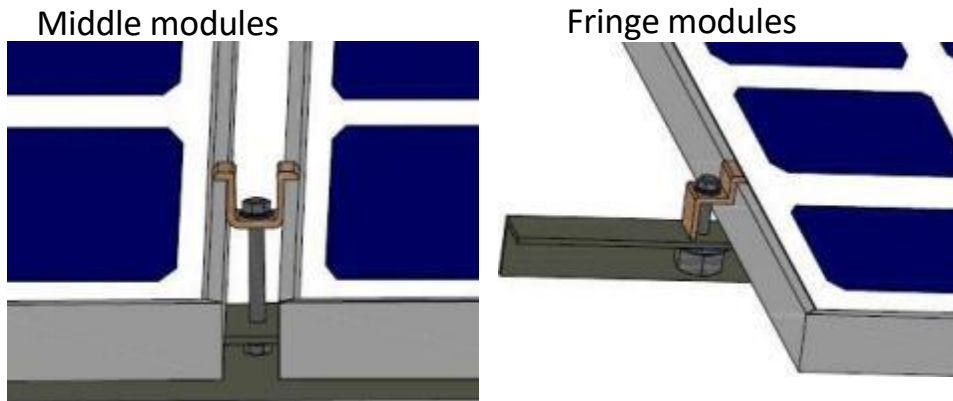

Figure 5: PV module installed at the side with Clamp fitting method

When installing modules using clamps on the long side of the frame, the applicable product types and installation locations are shown in figure 6 and table 4.

When installing modules using clamps on the short side of the frame, the applicable product types and installation locations are shown in figure 7 and table 5.

When installing modules using clamps on the long side & short side of the frame, the applicable product types and installation locations are shown in figure 8 and table 6.

When installing modules using clamps on the long side of the frame, the applicable product types and installation locations (The without C transparent backsheet series module) are shown in figure 9 and table 7.

2.3.1.1 Clamp Mounting on Long Sides of the Frames

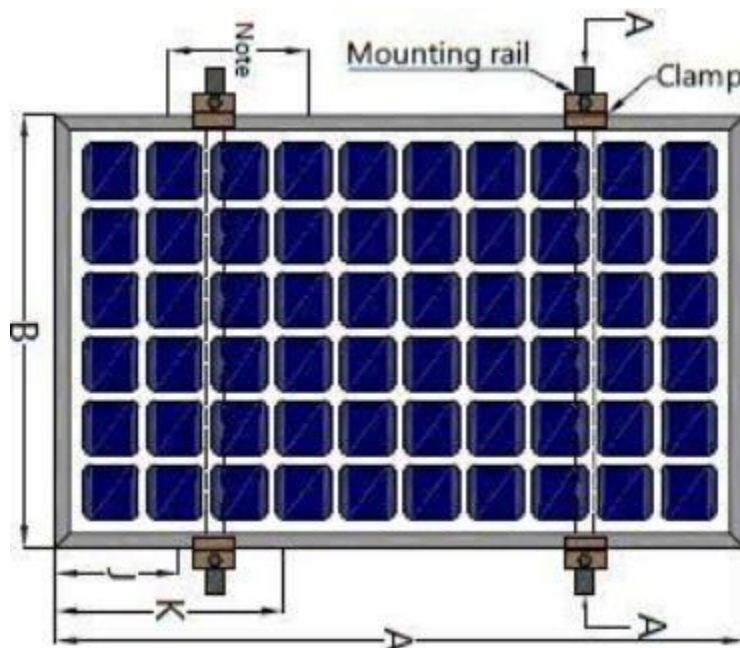
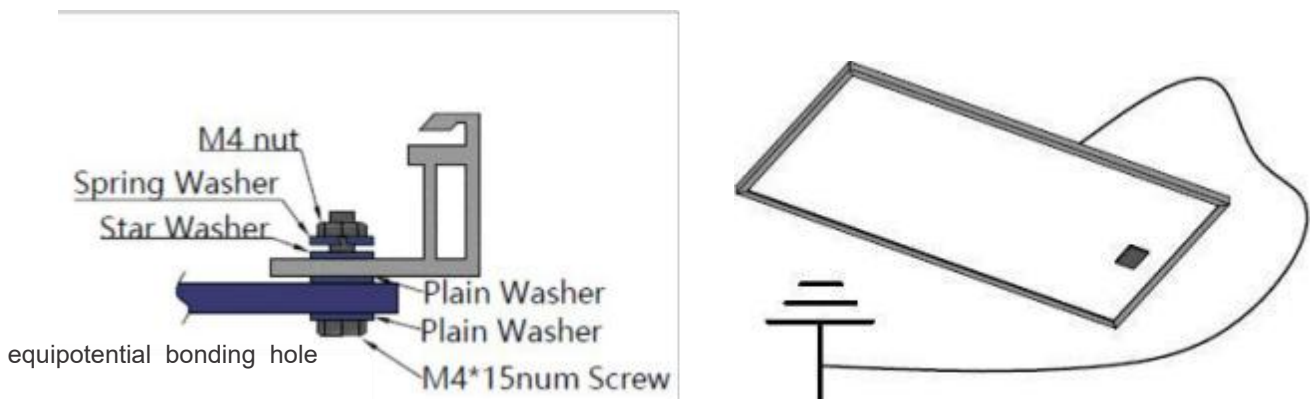

Figure 6: Installation of clamps on long side of frames

3. Wiring and Connection

- a) Before this procedure, please read the operation instructions of the PV system carefully. Make wiring by multi-connecting cables between the PV modules in series or parallel connection, which is determined by user's configuration requirement for system power, current and voltage.
- b) PV modules connected in series should have similar connectors of identical type current, and modules must not be connected together to create a voltage higher than the permitted system voltage. The maximum number of modules in series depends on system design, the type of inverter used and environmental conditions.
- c) The maximum fuse rating value in an array string can be found on the product label or in the product datasheet. The fuse rating value is also corresponding to the maximum reverse current that a module can withstand, i.e., when one string is in shade then the other parallel strings of modules will be loaded by the shaded string and the current will pass through to create a current circuit. Based on the maximum series fuse rating of module and local electrical codes and standards, make sure the modules strings in parallel are protected with the appropriate in-line string fusing.
- d) Open the combiner box of the control system and connect the conductor from the PV arrays to the combiner box in accordance with the design and local codes and standards. The cross-sectional area and cable connector capacity must satisfy the maximum short-circuit of the PV system (for a single component, we recommended that the cross-sectional area of cables current will be 4mm^2 and the rated current of connectors be more than 10A), otherwise cables and connectors will become overheating for large current. Please pay attention to the temperature limit of cables is 85°C .
- e) All module frames and mounting racks must be properly equipotential bonded in accordance with module frame using the local and national electrical codes. Attach the equipment equipotential bonded conductor to the hole and hardware provided. Note that a stainless-steel star washer is used between the ground wire and module frame (see Figure 10 below). This washer is used to avoid corrosion due to dissimilar metals. Tighten the screw securely.



Equipotential bonding installation of PV modules

When modules are in series connection, the string voltage is sum of every individual module in one string. When modules are in parallel connection, the current is sum of the individual module. Modules with different electric performance models cannot be connected in one string.

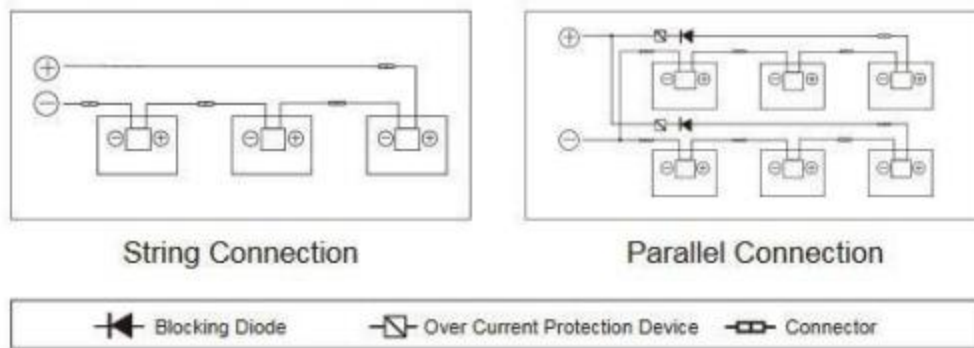

The maximum allowed quantity of modules in string connection shall be calculated according to relative regulations. The open circuit voltage value under the expected lowest temperature shall not exceed the maximum system voltage value allowed by modules and other values required by DC electric parts (maximum system voltage is DC1000V/DC1500V— actually system voltage is designed based on the selected module and inverter model.)

The VOC factor can be calculated by the following formula. $V_{oc} = 1 - \beta V_{oc}^* (25 - T)$

T: The expected lowest temperature of the installation site,

β ; VOC temperature coefficient (%/C) (refer to modules data sheet for further detail)

if there is reverse current exceeding the maximum fuse current flowing through the module, use overcurrent protection device with the same specifications to protect the module; if the parallel connection is more than 2, there must be an overcurrent protection device on each string of module.



- f) Follow the requirements of applicable local and national electrical codes.
- g) These modules contain factory installed by pass diodes. If these modules are incorrectly connected to each other, the bypass diodes, cable or junction box may be damaged.
- h) The cable of the junction box is defined as L, as showed below in Figure 11. For SPV Solar standard full cell module, L is 900/1200mm; for SPV Solar standard half-cell module, L is 350mm; and for customized module, L can be based on your condition. Please take the cable length into consideration before

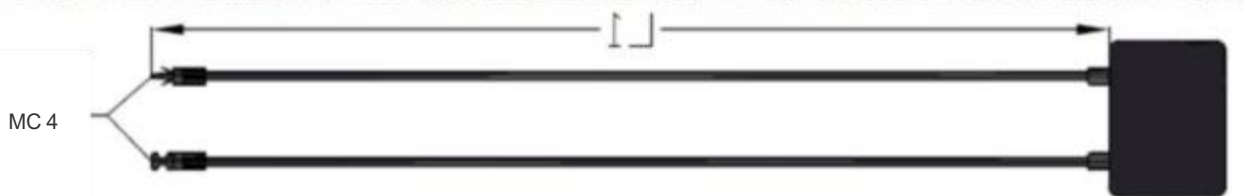

designing the wiring layout.

- i) It is recommended to use negatively grounded inverters to avoid the PID effect for non-PID free modules.
- j) If modules are connected in series, the total voltage is equal to the sum of individual voltages. The recommended as below,
System voltage $\geq N \cdot V_{oc} [1 + TC_{Voc} \cdot (T_{min} - 25)]$ Where
N module numbers in series
Voc Open circuit voltage (refer to product label or data sheet)
TCVoc Temperature coefficient of open circuit voltage (refer to product label or datasheet)
Tmin Minimum ambient temperature

3. Maintenance and Care

It is required to perform regular inspection and maintenance of the modules, especially during the warranty period. To ensure optimum module performance, SPV Solar recommends the following maintenance measures:

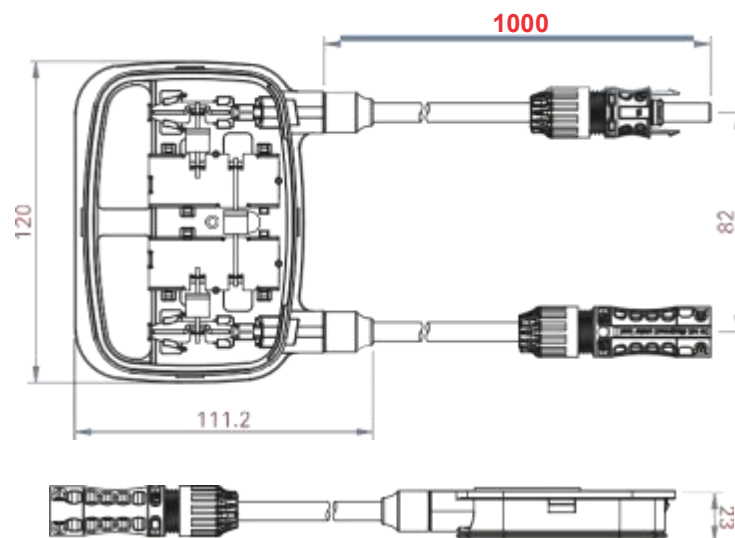



3.1 Visual Inspection

Inspect the modules visually to find if there are any visual defects, if there are, the following items should be evaluated:

- a) If modules are observed having slight cell color differences at different angles, this is a normal phenomenon of modules with anti-reflection coating technology.
- b) Whether the glass is broken.
- c) No sharp objects are in contact with the PV module surfaces.
- d) PV modules are not shaded by unwanted obstacles and; or foreign material.
- e) Corrosion along the cells' bus-bar. The corrosion is caused by moisture intrusion through the module back sheet. Check the back sheet for damage.
- f) Check whether the back sheet is burnt.
- g) Check if screws and mounting brackets are tight, adjust and tighten as necessary.

3.2 Cleaning

- a) A buildup of dust or dirt on the module(s) front face will result in a decreased energy output. Clean the panel(s) preferably once per annum, if possible (depend on site conditions), using a soft cloth dry or damp, as necessary. Water with high mineral content may leave deposits on the glass surface and is not recommended.
- b) Never use abrasive material under any circumstances.
- c) In order to reduce the potential for electrical and thermal shock, SPV Solar recommends cleaning PV modules during early morning or late afternoon hours when solar radiation is low and the modules are cooler, especially in regions with hotter temperatures.
- d) Never attempt to clean a PV module with broken glass or other signs of exposed wiring, as this presents a shock hazard.
- e) Never use chemicals when cleaning modules as this may affect the module warranty and energy output.

3.3 Inspection of Connector and Cable

It's recommended to implement the following preventive maintenance every 6 months:

- a) Check the sealing gels of the junction box for any damage.
- b) Examine the PV module(s) for signs of deterioration. Check all wiring for possible rodent damage, weathering and that all connections are tight and corrosion free. Check electrical leakage to ground.

4. Electrical Specification

The module electrical ratings are measured under Standard Test Conditions, which are 1000W/m², irradiance with AM 1.5 spectrum and 25 deg (77F°) ambient temperature. The module might produce more or less voltage or current than rated value in uncertainty condition.

5. Disclaimer of Liability

Because the use of the manual and the conditions or methods of installation, operation, use and maintenance of photovoltaic (PV) product are beyond SPV Solar's control, SPV Solar does not accept responsibility and expressly disclaims liability for loss, damage, or expense arising out of or in any way connected with such installation, operation, use or maintenance.

No responsibility is assumed by SPV Solar for any infringement of patents or other rights of third parties, which may result from use of the PV product. NO license is granted by implication or otherwise under any patent or patent rights.

The information in this manual is based on SPV Solar's knowledge and experience and is believed to be reliable, but such information including product specification (without limitations) and suggestions do not constitute a warranty, expresses or implied. SPV Solar reserve the right to change the manual, the PV produce, the specifications, or product information sheets without prior notice.



SpolarPV model list		
Single glass module	Double glass module	
156.75mm Cell		
With 156 mono c-Si cell:	/	
SPVxxx-PM2-72(-xxx=325-385, in steps of 5, 60 cells) SPVxxx-PM2-60(xxx=275-320, in steps of 5, 60 cells)		
SPVxxx-PM2-72BS(xxx=315-385, in steps of 5, 60 cells) SPVxxx-PM2-60BS(xxx=265-320, in steps of 5, 60 cells) SPVxxx-PM2-36BS (xxx=185-195, in steps of 5, 36 cells)		
158.75mm Cell		
With 158 mono c-Si cell:	With ½ cut of 158 mono c-Si cell: SPVxxx-PM3-144BD (xxx=390-415, in steps of 5, 144 cells) SPVxxx-PM3-120BD (xxx=325-345, in steps of 5, 120 cells)	
SPVxxx-PM3-72 (xxx=385-400, in steps of 5, 72 cells) SPVxxx-PM3-60 (xxx=320-335, in steps of 5, 60 cells) SPVxxx-PM3-36 (xxx=185-200, in steps of 5, 36 cells)		
SPVxxx-PM3-72BS (xxx=385-400, in steps of 5, 72 cells) SPVxxx-PM3-60BS (xxx=320-335, in steps of 5, 60 cells) SPVxxx-PM3-36BS (xxx=185-200, in steps of 5, 36 cells)		
SPVxxx-XM3-72 (xxx=385-400, in steps of 5, 72 cells) SPVxxx-XM3-60 (xxx=320-335, in steps of 5, 60 cells) SPVxxx-XM3-36(xxx=185-200, in steps of 5, 36 cells)		
SPVxxx-XM3-72BS (xxx=385-400, in steps of 5, 72 cells) SPVxxx-XM3-60BS (xxx=320-335, in steps of 5, 60 cells) SPVxxx-XM3-36BS (xxx=185-200, in steps of 5, 36 cells)		
With ½ cut of 158 mono c-Si cell:		
SPVxxx-PM3-144((xxx=325-345, in steps of 5, 144cells) SPVxxx-PM3-120(xxx=275-340, in steps of 5, 120 cells)		
SPVxxx-PM3-144BS (xxx=390-415, in steps of 5, 144 cells) SPVxxx-PM3-120BS (xxx=325-345, in steps of 5, 120 cells)		
166mm Cell		
With ½ cut of 166 mono c-Si cell:		With ½ cut of 166 mono c-Si cell: SPVxxx-PM6-144BD (xxx=420-460, in steps of 5, 144 cells) SPVxxx-PM6-132BD(xxx=385-420, in steps of 5, 132 cells) SPVxxx-PM6-120BD (xxx=350-385, in steps of 5, 120 cells) SPVxxx-PM6-108BD (xxx=315-345, in steps of 5, 108 cells) SPVxxx-PM6-96BD (xxx=280-305, in steps of 5, 96 cells) SPVxxx-PM6-72BD(xxx=210-230, in steps of 5, 72 cells)
SPVxxx-PM6-144(xxx=435-465, in steps of 5, 144 cells) SPVxxx-PM6-132 (xxx=385-425, in steps of 5, 132 cells) SPVxxx-PM6-120(xxx=350-385, in steps of 5, 120 cells) SPVxxx-PM6-108 (xxx=315-345, in steps of 5, 108 cells) SPVxxx-PM6-96 (xxx=280-305, in steps of 5, 96 cells) SPVxxx-PM6-72 (xxx=210-230, in steps of 5, 72 cells)		
SPVxxx-PM6-144BS (xxx=420-460, in steps of 5, 144 cells) SPVxxx-PM6-132BS (xxx=385-420, in steps of 5, 132 cells) SPVxxx-PM6-120BS (xxx=350-385, in steps of 5, 120 cells) SPVxxx-PM6-108BS (xxx=315-345, in steps of 5, 108 cells) SPVxxx-PM6-96BS (xxx=280-305, in steps of 5, 96 cells) SPVxxx-PM6-72BS (xxx=210-230, in steps of 5, 72 cells)		

SpolarPV model list

Single glass module	Double glass module
182 Cell	
With ½ cut of 182 mono c-Si cell:	With ½ cut of 182 mono c-Si cell:
SPVxxx-PM10-156 (xxx=565-600, in steps of 5, 156 cells) SPVxxx-PM10-144(xxx=520-555, in steps of 5, 144 cells) SPVxxx-PM10-132(xxx=480-505, in steps of 5, 132 cells) SPVxxx-PM10-120 (xxx=435-460, in steps of 5, 120 cells) SPVxxx-PM10-108(xxx=390-415, in steps of 5, 108 cells) SPVxxx-PM10-96 (xxx=350-370, in steps of 5, 96 cells) SPVxxx-PM10-72 (xxx=260-275, in steps of 5, 72 cells)	SPVxxx-PM10-156BD(xxx=565-600, in steps of 5, 156 cells) SPVxxx-PM10-144BD (xxx=520-555, in steps of 5, 144 cells) SPVxxx-PM10-132BD (xxx=480-505, in steps of 5, 132 cells) SPVxxx-PM10-120BD (xxx=435-460, in steps of 5, 120 cells) SPVxxx-PM10-108BD (xxx=390-415, in steps of 5, 108 cells) SPVxxx-PM10-96BD (xxx=350-370, in steps of 5, 96 cells) SPVxxx-PM10-72BD (xxx=260-275, in steps of 5, 72 cells)
SPVxxx-PM10-156BS (xxx=565-600, in steps of 5, 156 cells) SPVxxx-PM10-144BS (xxx=520-555, in steps of 5, 144 cells) SPVxxx-PM10-132BS(xxx=480-505, in steps of 5, 132 cells) SPVxxx-PM10-120BS (xxx=435-460, in steps of 5, 120 cells) SPVxxx-PM10-108BS (xxx=390-415, in steps of 5, 108 cells) SPVxxx-PM10-96BS (xxx=350-370, in steps of 5, 96 cells) SPVxxx-PM10-72BS(xxx=260-275, in steps of 5, 72 cells)	SPVxxx-TM10-144BD(xxx=555-585, in steps of 5, 144 cells) SPVxxx-TM10-120BD(xxx=460-490, in steps of 5, 120 cells) SPVxxx-TM10-108BD(xxx=410-440, in steps of 5, 108 cells)
210 Cell	
With ½ cut of 210 mono c-Si cell:	With ½ cut of 210 mono c-Si cell:
SPVxxx-PG12-132(xxx=640-670, in steps of 5, 132 cells) SPVxxx-PG12-120(xxx=580-610, in steps of 5, 120 cells) SPVxxx-PG12-110(xxx=535-555, in steps of 5, 110 cells)	SPVxxx-PG12-132BD (xxx=640-675, in steps of 5, 132 cells) SPVxxx-PG12-120BD(xxx=580-610, in steps of 5, 120 cells) SPVxxx-PG12-110BD (xxx=530-555, in steps of 5, 110 cells)
With ½ cut of 210 mono c-Si cell:	With ½ cut of 210 mono c-Si cell: third-cut cells
SPVxxx-PG12-132BS (xxx=640-670, in steps of 5, 132 cells) SPVxxx-PG12-120BS (xxx=580-610, in steps of 5, 120 cells) SPVxxx-PG12-110BS(xxx=535-555, in steps of 5, 110 cells)	SPVxxx-PG12-T132BD(xxx=480-520, in steps of 5, 150 cells) SPVxxx-PG12-T120BD(xxx=385-415, in steps of 5, 120 cells)
With ⅓ cut of 210 mono c-Si cell:	With ½ cut of 210 mono c-Si cell:TOPCon SPVxxx-TG12-132BD (xxx=660-680, in steps of 5, 132 cells) SPVxxx-TG12-120BD (xxx=600-620, in steps of 5, 120 cells) SPVxxx-TG12-110BD (xxx=550-570, in steps of 5, 110 cells)
SPVxxx-PG12-T150 (xxx=480-520, in steps of 5, 150 cells) SPVxxx-PG12-T120 (xxx=385-415, in steps of 5, 120 cells)	
With ½ cut of 210 mono c-Si cell: SPVxxx-PG12-T150BS(xxx=480-520, in steps of 5, 150 cells) SPVxxx-PG12-T120BS (xxx=385-415, in steps of 5, 120 cells)	
Maximum system voltage(V)	1500V
Maximum overcurrent protection rating (A)	25/30A
Nominal module operating temperature (C°)	-40 to +85
Power tolerance Pmax(WP)	0/+4.99
Electrical Characteristics of each model	Please refer to the product specification on the company website.
Mechanical load	Front side 5400 Pa, Rear side 2400 Pa

