

**Anexa 13 Lampa cu Fanta, Model: TSL-900Z, SHANGHAI MEDIWORKS****PRECISION INSTRUMENTS CO., LTD./ Tomey****Nr. de inregistrare AMDM: DM000739305**

| Specificarea tehnică deplină solicitată, Standarde de referință  | Specificarea tehnică deplină oferita, Standarde de referință   |
|--|--|
| <p>Descriere: Microscop binocular care permite examinarea stereoscopică detaliată a structurilor oculare.</p> <p>Parametrul                      Specificația</p> <p>Sistemul de iluminare:</p> <p>Lățimea fantei, mm      0-14 minimum, ajustabilă</p> <p>Lungimea fantei, mm    0-14 minimum, ajustabilă</p> <p>Unghi de tăiere    0 ~ 180 °, reglabil continuu</p> <p>Filtre    Minim: albastru, verde, absorpție de căldură</p> <p>Microscopul:</p> <p>    Tipul    Binocular</p> <p>    Mărire totală    12x minimum</p> <p>    Înclinare        5°,10°,15°,20°</p> <p>    Metoda de schimbare a măririi    Să se indice</p> <p>    Gama de reglare a dioptriei, dioptrii    de la -7 la +7 minim</p> <p>Gama de mișcare:</p> <p>    Deplasare laterală, mm    <math>\geq 100</math></p> <p>    Deplasare în adâncime, mm    <math>\geq 100</math></p> <p>    interval pupilă    52-85 mm</p> <p>    Deplasare în înălțime, mm    <math>\geq 30</math></p> <p>    Reglare fină de la joystick, mm <math>\geq \pm 10</math></p> <p>    Reglarea înălțimii bărbiei, mm <math>\geq 70</math></p> <p>Alimentarea, 220 V, 50 Hz                      Obligatoriu</p> <p>Accesorii</p> <p>    Setul standard</p> <p>    masă cu elevație electrică                      1 buc</p> <p>    Bec      min. 2 buc.</p> | <p>Descriere: Microscop binocular care permite examinarea stereoscopică detaliată a structurilor oculare. Specificații tehnice minime:</p> <p>Parametrul                      Specificația</p> <p>Sistemul de iluminare:</p> <p>Lățimea fantei, mm, 0-14 minimum, ajustabilă -brosura</p> <p>Lungimea fantei, mm, 0-14 minimum, ajustabilă- brosură</p> <p>Unghi de tăiere    0 ~ 180 °, reglabil continuu- manual, pag 2</p> <p>Filtre minim: albastru, verde, absorpție de căldură</p> <p>Microscopul:</p> <p>    Tipul    Binocular - brosură</p> <p>    Mărire totală    12.5x</p> <p>    Înclinare        5°,10°,15°,20° -brosura</p> <p>    Metoda de schimbare a măririi:</p> <p>    Gama de reglare a dioptriei, dioptrii de la -8 la +8</p> <p>Gama de mișcare:</p> <p>    Deplasare laterală, - mm 110 - brosură,</p> <p>    Deplasare în adâncime - 115 mm- brosură</p> <p>    interval pupilă    52-80 mm - brosură</p> <p>    Deplasare în înălțime, - mm 30 - brosură</p> <p>    Reglare fină de la joystick, mm 15 - manual, pag.3</p> <p>    Reglarea înălțimii bărbiei, 80 mm - manual, pag.3</p> <p>Alimentare: 100–240V, 50/60 Hz</p> <p>Accesorii</p> <p>    Setul standard</p> <p>    masă cu elevație electrică-1 buc, <b>Model TT-4060</b></p> <p>    Bec- 2 buc.</p> |

# Slit Lamps

## TSL-900H/TSL-900Hdigital/TSL-900Z

The TOMEY TSL-900 series leaves nothing to be desired. Easy and ergonomic handling, high quality, accuracy and reliability are provided. Our slit lamps are equipped with a complete filter set-up and many accessories, including a yellow filter module, applanation tonometer, measuring eyepiece and mounting plate. It's your complete slit lamp solution.

### Excellent features

- + High-quality optics
- + LED illumination
- + Rotating drum with five-step magnification
- + Multiple integrated filters
- + Ergonomic operation

#### TSL-900Hdigital only

- + High-resolution digital imaging system with 5.0/12.0 MP
- + Slit lamp documentation by a fully integrated imaging solution



TSL-900Hdigital



TSL-900H



TSL-900Z

## Specifications

| TSL-900H/TSL-900Hdigital         |   | TSL-900Z |
|----------------------------------|---|----------|
| <b>OPTICAL SYSTEM</b>            |   |          |
| Type                             | Galilean converging binoculars 10°  |          |
| Magnification                    | Rotating drum change x6.3, x10, x16, x25, x40   |          |
| Eyepiece                         | x12.5   |          |
| Field of view                    | 40x (Ø 5.7 mm), 25x (Ø 8.9 mm), 16x (Ø 14 mm), 10x (Ø 22.3 mm), 6x (Ø 36.2 mm)                        |          |
| Interpupillary distance          | 52 mm to 80 mm  |          |
| Objective lens convergence angle | 13°   |          |
| Dioptr adjustment                | ±8 D  |          |
| <b>SLIT PROJECTION AND BASE</b>  |   |          |
| Slit width                       | 0 mm to 14 mm continuously variable   |          |
| Slit length                      | 1 mm to 14 mm continuously variable   |          |
| Aperture diameters               | Ø 14 mm, Ø 10 mm, Ø 5 mm, Ø 3 mm, Ø 2 mm, Ø 1 mm, Ø 0.2 mm, Ø 14 mm, Ø 8 mm, Ø 5 mm, Ø 3 mm, Ø 0.2 mm |          |
| Filters                          | Heat-absorbing filter, red-free filter, cobalt blue filter, ND filter, diffuser                       |          |
| Slit angle                       | ±90° continuous   |          |
| Slit inclination                 | 4 step: 5°, 10°, 15°, 20°   |          |
| Base travel                      | 30 mm z-axis, 110 mm x-axis, 115 mm y-axis  |          |
| Horizontal fine adjustment       | 12 mm   |          |
| Fixation lamp                    | LED   |          |
| Light source                     | LED / 12 V  |          |
| Luminance                        | ≥150klx   |          |

| <b>ADDITIONAL FEATURES</b> |  |
|----------------------------|--|
| Optional features          | Yellow filter integrated to optical body |
| Optional devices           | TAT-80R, measuring eyepiece              |

| <b>DIMENSIONS AND ELECTRICAL REQUIREMENTS</b> |                              |                              |
|---|------------------------------|------------------------------|
| Dimensions WDH                                | 330 mm x 390-460 mm x 650 mm | 330 mm x 390-460 mm x 460 mm |
| Weight  | 17 kg                        | 16 kg                        |
| Power supply unit                             | 100 V to 240 V, 50/60 Hz     |                              |
| Power supply output                           | 12 V DC to 15 V DC           |                              |

| <i>TSL-900Hdigital only</i> |  |
|-----------------------------|--|
| <b>SPECIFICATIONS</b>       |  |
| Illumination system         | External LED background illumination system, IR background illumination module |

| <i>Digital versions only</i> |  |
|------------------------------|--|
| <b>CAMERA SYSTEM</b>         |  |
| Resolution                   | 5.0 MP, 2592 x 1944<br>12.0 MP, 4056 x 3040      |
| Connectivity                 | USB 3.0 high-speed 480 Mbps port                 |
| Sensor type                  | 1/4-inch high-speed high-definition image sensor |
| Video format                 | MP4 H.264, 2592 x 1944                           |
| Frame rate                   | 30 fps   |
| Exposure mode                | Automatic exposure, automatic gain               |

TOMEY EUROPE  
TOMEY GMBH



tomey.de

TOMEY GmbH is the European headquarter of TOMEY Corporation,  
2-11-33 Noritakeshinmachi Nishi-Ku, Nagoya, 451-0051, Japan

2025/06 - subject to change without notice

Always read and follow the instructions for use.  
Not all products, services or offers are approved or offered in every market. Please note that the current status of approval for the labelling, instructions and contents of the brochure may vary from one country to another.



---

# USER MANUAL

Slit Lamp Microscope

Model: TSL-900Z



## Preface

Thank you for purchasing TSL-900Z Slit Lamp Microscope. We totally provide its user manuals in 24 languages on Tomey GmbH official website, including Latvian, Dutch, French, German, Bulgarian, English, Greek, Czech, Danish, Estonian, Swedish, Finnish, Hungarian, Italian, Lithuanian, Polish, Portuguese, Romanian, Slovak, Slovenian, Spanish, Croatian, Turkish and Norwegian. To access, please visit Tomey GmbH website at [www.tomey.de](http://www.tomey.de).

The following is the description and specification of our product:

## General description:

- ✉ This operation instruction is an integral part of the Slit Lamp Microscope. Product-related operation instructions and technical instructions are given in this manual. The address for the user inquiry is recorded on the last page of this manual.
- ✉ This manual contains operation instruction and technical instruction. The equipment classification of the Slit Lamp Microscope according to the requirements of IEC 60601-1 is also given in this manual.
- ✉ The IEC 60601-1 standard stipulates that the applicable marks have been permanently attached to the instrument and are also described in the manual.
- ✉ Working principle: A beam of light attached to the slit lamp projects to the patients' eye, which forms an optical section of the living tissue of the eye, in this way the doctor can finish the observation and examination.
- ✉ Slit Lamp Microscopes are used to observe the disease of the anterior segments and tissue damage of eyes.
- ✉ The slit lamp microscope adopts the latest technology of LED light source, low voltage, low power consumption, and higher light efficiency, uniform light emission, and good color reproduction;

## Intended use

### ● Intended Purpose

The device is intended for use in eye examination of the anterior eye segment. It is used to aid in the diagnosis of diseases or trauma which affect the structural properties of the anterior eye segment.

### ● Indications for Use

The use of the slit lamp is indicated for the following medical conditions:

- Local and systemic diseases affecting the eye
- Lesions and defects of the anterior segment
- Acute infections and inflammations
- Presence of intraocular foreign bodies
- Other traumata of the eye

### ● Intended Population

This device is intended for use on human patients with the physical ability to sit in front of a

slit lamp with their head resting against the headrest in a steady position and the mental ability to follow instructions.

- Intended Users

The device is intended to be used by well-trained and authorized healthcare professionals.

- Contraindications

There are no known contraindications.

### Warning statement:

The installation, operation and use of the device shall only be for the intended purpose, which is defined in this manual. Please pay attention to the warning information described in this manual, related to safety. Any unauthorized personnel shall not conduct the activities on the device.

### Instrument classification:

According to the IEC 60601-1 classification standard of medical electrical equipment, the slit lamp microscope is a general equipment of Class I continuous operation instrument, which cannot be used under two circumstances: a flammable anesthetic gas and air mixture, oxygen or nitrous oxide gas and air mixture.

### The specification of this slit lamp microscope:

|                                |   |
|--------------------------------|---|
| Microscope type:               | Galilean-Type   |
| Magnification change:          | Five steps revolving Drum                                       |
| Total magnification ratio:     | 6.3X、10X、16X、25X、40X  |
| Eyepieces:                     | 12.5X   |
| Angle between eyepieces:       | 10°   |
| Pupillary distance adjustment: | 52mm ~ 80mm   |
| Diopter adjustment:            | -8D – +8D   |
| Field of view:                 | 40X(5.7mm), 25X(8.9mm), 16X(14mm),<br>10X(22.3mm), 6.3X(36.2mm) |

### Slit Illumination:

|                        |   |
|------------------------|---|
| Slit width:            | Continuously variable from 0 to 14mm (at 14mm, slit becomes a circle) |
| Slit length:           | Continuously variable from 1mm to 14mm                                |
| Aperture diameters:    | Ø14mm, Ø8mm, Ø3.5mm, Ø0.2mm   |
| Slit angle:            | 0-180 (Adjustable both vertical and horizontal)                       |
| Filters:               | Heat-absorbing filter, Red-free, Cobalt Blue                          |
| Lamp:                  | 3V/3W LED module  |
| Luminance:             | ≥150klx   |
| LED color-temperature: | 3000-4000K  |

### Base:

|                        |       |
|------------------------|-------|
| Longitudinal movement: | 115mm |
|------------------------|-------|

---

|                     |       |
|---------------------|-------|
| Lateral movement:   | 110mm |
| Fine base movement: | 15mm  |
| Vertical movement:  | 30mm  |

**Chin-Rest:**

|                    |      |
|--------------------|------|
| Vertical movement: | 80mm |
|--------------------|------|

**Power Supply:**

|                |                                 |
|----------------|---------------------------------|
| Input:         | ~100V-240V, 50/60Hz             |
| Rated current: | 1.2A                            |
| Output:        | Lamp: 3V (LED)<br>Fixation: 15V |

**Size & Weight:**

|               |                       |
|---------------|-----------------------|
| Package size: | 770mm × 470mm × 570mm |
| Gross weight: | 22Kg                  |
| Net weight:   | 16Kg                  |

**Working Environment:**

|                    |                  |
|--------------------|------------------|
| Temperature:       | +5°C ~ +40°C     |
| Relative humidity: | ≤90%             |
| Air pressure:      | 860hPa ~ 1060hPa |

**Storage Environment:**

|                    |                  |
|--------------------|------------------|
| Temperature:       | -40°C ~ +55°C    |
| Relative humidity: | ≤90%             |
| Air pressure:      | 860hPa ~ 1060hPa |

**Transportation Environment:**

|                    |                  |
|--------------------|------------------|
| Temperature:       | -40°C ~ +55°C    |
| Relative humidity: | ≤90%             |
| Air pressure:      | 860hPa ~ 1060hPa |

**General Requirements for Safety**

Dear customers, please read the instruction manual carefully before using our products to avoid accidental mechanical hazards and improper use of the user, resulting in unclear images and diagnostic errors. In particular, carefully read the following safety precautions to prevent the product is damaged, personal injury, and other hazards and accidents that may occur.



- ☞ The product can only be used by qualified medical staff.
- ☞ Do not disassemble or attempt to perform operations that are not described in this instruction manual. If the operation is not performed properly, excessive force may cause damage to the machine or personal injury. If the instrument fails, please read













the troubleshooting guide carefully; follow the troubleshooting methods and steps to troubleshoot the problem; if the problems remain unsolved, please contact the authorized distributor or our after-sale service department.

- ☞ Do not store and use in a flammable, explosive, high temperature, high humidity and dusty environment; use it in a clean room, keeping the product clean and dry.
- ☞ Other medical instruments and equipment that installed at the same site must comply with the same electromagnetic compatibility principles. Equipment that cannot comply with or is known to have poor electromagnetic compatibility must be installed at least 3 meters away from the equipment and must be powered by a different power cord.
- ☞ Please pay attention to the rating of all electrical connection ports.
- ☞ Before using the instrument, please check all the wires are correctly connected; if the wires are inappropriately connected it may cause the instrument to be short-circuited, which may cause product damage and personal injury.
- ☞ Users should pay attention when using the instrument, and be careful when moving the parts to avoid damage due to the moving of the base and tilting of the projection tube.
- ☞ When replacing fuses and other electrical components, turn off the main power switch. Replace the fuse that meets the specifications specified in this manual.
- ☞ If there is a need to replace power cord, please use the power cord specified in this manual.
- ☞ Don't touch the surface of the lens and prism with hand or hard objects.
- ☞ When the device is not operating, the power should be turned off, and cover the device with dust cover.
- ☞ To prevent the instrument from falling down to floor, it should be placed on the floor where the inclination angle is less than 10°.
- ☞ Please deal with the waste disposal produced by the machine following relevant laws and regulations.
- ☞ Please read the safety signs and other illustrations used on this instrument carefully to use the device safely.
- ☞ The chin rest has a load capacity of 10 kg.

## THE SAFETY MARKS, PICTURES USED IN THIS INSTRUMENT

According to the IEC 60601-1 standard, the following figures, symbols and marks are used on the products. For the specific meanings, see Table 1 below:

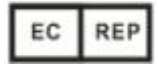
| No. | Mark  | Description        |
|-----|---|--------------------|
| 1   |  | TYPE B             |
| 2   |  | Date of Production |

|    |   |   |
|----|---|---|
| 3  |    | Consult instructions for use.   |
| 4  |    | WEEE mark. Please deal with the waste disposal produced by the machine following relevant laws and regulations. |
| 5  |    | CE mark   |
| 6  |    | Part Number   |
| 7  |    | Serial Number   |
| 8  | Output  | Located on the base, indicate outlet of the power   |
| 9  | Input   | Located on the base, indicate input of the power  |
| 10 |    | Located on the base, use with on and off  |
| 11 |   | The mark of light dimmer  |
| 12 |  | Caution: Possibly hazardous optical radiation emitted from this product.  |
| 13 |  | Medical device  |
| 14 |  | Manufacturer information  |
| 15 |  | Authorized representative in the European Community   |
| 16 |  | Authorized representative in Switzerland  |

## Catalog

|  |    |
|--|----|
| Preface .....  | 1  |
| EMC precautions: .....   | 7  |
| 1 Graphical description of each part of the slit lamp microscope ..... | 11 |
| 2 Installation .....   | 12 |
| 2.1 Check List .....   | 13 |
| 2.2 Installation procedure .....                                       | 15 |
| 2.3 Checking procedure .....   | 16 |
| 3 Operation procedure .....  | 17 |
| 3.1 Diopter compensation and Pupillary distance adjustment .....       | 17 |
| 3.2 Patient's head position and use of fixation target .....           | 18 |
| 3.3 How to use moving base .....                                       | 18 |
| 3.4 Operation of illumination system .....                             | 18 |
| 3.5 Operation notes .....  | 19 |
| 4 Cleaning and maintenance .....                                       | 19 |
| 4.1 Cleaning .....   | 19 |
| 4.2 Protection .....   | 21 |
| 4.3 Replace the chin-rest paper .....                                  | 21 |
| 4.4 Rail cover removal instructions .....                              | 21 |
| 5 Trouble shooting .....   | 23 |

## EMC precautions:

Slit Lamp Microscope needs special precautions regarding EMC and put into service according to the EMC information provided in the user manual and other documents; Slit Lamp Microscope conforms to this EN 60601-1-2:2007+AC:2010/IEC 60601-1-2 standard for both immunity and emissions.

Nevertheless, special precautions need to be observed:

- The use of accessories and cable other than those specified, with the exception of accessories and cables sold of Slit Lamp Microscope as replacement parts for internal components, may result in increased EMISSIONS or decreased IMMUNITY or decreased LIFESPAN of the Slit Lamp Microscope.
- Slit Lamp Microscope should not be used adjacent to or stacked with other equipment. In case adjacent or stacked use is necessary, The Slit Lamp Microscope should be observed to verify normal operation in the configuration in which it will be used.

### EMC Information

Guidance and manufacturer's declaration - electromagnetic emissions - for all ME EQUIPMENT and ME SYSTEM.

| Table 1:Guidance and manufacturer's declaration – electromagnetic emissions   |            |   |
|---|------------|---|
| The slit lamp microscope is intended for use in the electromagnetic environment specified below. The customer or the user of the slit lamp microscope should assure that it is used in such an environment. |            |   |
| Emissions test  | Compliance | Electromagnetic environment - guidance  |
| RF emissions<br>CISPR 11  | Group 1    | The slit lamp microscope uses RF energy only for its internal function. Therefore, its RF emissions are very low and are not likely to cause any interference in nearby electronic equipment                          |
| RF emissions<br>CISPR 11  | Class A    | The slit lamp microscope is suitable for use in all establishments other than domestic and those directly connected to the public low-voltage power supply network that supplies buildings used for domestic purposes |
| Harmonic emissions<br>IEC 61000-3-2   | Class A    |   |
| Voltage fluctuations/<br>Flicker emissions<br>IEC 61000-3-3   | Complies   |   |

Guidance and manufacturer's declaration - electromagnetic immunity - for all ME EQUIPMENT and ME SYSTEM.

| Table 2:Guidance and manufacturer's declaration – electromagnetic immunity  |  |   |   |
|---|--|---|---|
| The slit lamp microscope is intended for use in the electromagnetic environment specified below. The customer or the user of the slit lamp microscope should assure that it is used in such an environment. |  |   |   |
| Immunity test   | IEC 60601<br>Test level  | Compliance<br>level   | Electromagnetic environment - guidance  |
| Electrostatic<br>Discharge(ESD)<br>IEC 61000-4-2  | ±6 kV contact<br>±8 kV air   | ±6 kV<br>contact<br>±8 kV air                                   | Floors should be wood, concrete or ceramic tile. If floors are covered with synthetic material, the relative humidity should be at least 30%. |
| Electrical fast<br>transient/burst<br>IEC 61000-4-4   | ±2 kV for power<br>supply lines<br>±1 kV for input/output<br>lines | ±2 kV for<br>power supply<br>lines<br>±1 kV for<br>input/output | Mains power quality should be that of a typical commercial or hospital environment  |

|  |   |   |  |
|--|---|---|--|
| Surge<br>IEC 61000-4-5   | ±1 kV lines to lines<br>±2 kV lines to earth  | lines<br>±1 kV lines to lines<br>±2 kV lines to earth   | Mains power quality should be that of a typical commercial or hospital environment.  |
| Voltage dips, short interruptions and voltage variations on power supply input lines<br>IEC 61000-4-11 | <5% $U_T$<br>(>95% dip in $U_T$ )<br>For 0,5 cycle<br>40% $U_T$<br>(60% dip in $U_T$ )<br>For 5 cycle<br>70% $U_T$<br>(30% dip in $U_T$ )<br>For 25 cycle<br><5% $U_T$<br>(>95% dip in $U_T$ )<br>For 5 cycle | <5% $U_T$<br>(>95% dip in $U_T$ )<br>For 0,5 cycle<br>40% $U_T$<br>(60% dip in $U_T$ )<br>For 5 cycle<br>70% $U_T$<br>(30% dip in $U_T$ )<br>For 25 cycle<br><5% $U_T$<br>(>95% dip in $U_T$ )<br>For 5 cycle | Mains power quality should be that of a typical commercial or hospital environment. If the user of slit lamp microscope requires continued operation during power mains interruptions, it is recommended that the slit lamp microscope be powered from an uninterruptible power supply or a battery. |
| Power frequency (50/60Hz) magnetic field<br>IEC 61000-4-8  | 3A/m  | 3A/m  | Power frequency magnetic fields should be at levels characteristic of a typical location in a typical commercial or hospital environment   |
| Note: $U_T$ is the a.c. mains voltage prior to application of the test level.                          |   |   |  |

Guidance and manufacturer’s declaration – electromagnetic immunity for ME EQUIPMENT and ME SYSTEM that are not LIFE-SUPPORTING.

| Table 3: Guidance and manufacturer’s declaration – electromagnetic immunity   |                            |                  |  |
|---|----------------------------|------------------|--|
| The slit lamp microscope is intended for use in the electromagnetic environment specified below. The customer or the user of the slit lamp microscope should assure that it is used in such an environment. |                            |                  |  |
| Immunity test   | IEC 60601 test level       | Compliance level | Electromagnetic environment-guidance   |
| Conducted RF<br>IEC 61000-4-6   | 3 Vrms<br>150 kHz to 80MHz | $V_1=3V$         | Portable and mobile RF communications equipment should be used no closer to any part of the SYSTEM, including cables, than the recommended separation distance calculated from the equation applicable to the frequency of the transmitter.<br><br>Recommended separation distance<br>$d = \left[ \frac{3.5}{V_1} \right] \sqrt{P}$ 150kHz to 80 MHz |
| Radiated RF<br>IEC 61000-4-3  | 3 Vrms<br>80MHz to 2.5GHz  | $E_1=3V/m$       | $d = \left[ \frac{3.5}{E_1} \right] \sqrt{P}$ 80MHz to 800MHz<br><br>$d = \left[ \frac{7}{E_1} \right] \sqrt{P}$ 800MHz to 2.5GHz<br><br>Where $P$ is the maximum output power rating of the transmitter in watts(W) according to the transmitter manufacturer and $d$ is the recommended separation distance in meters (m).                         |

|  |  |  |  |
|--|--|--|--|
|  |  |  | <p>Field strengths from fixed RF transmitters, as determined by an electromagnetic site survey, should be less than the compliance level in each frequency range.</p> <p>Interference may occur in the vicinity of equipment marked with the following symbol:</p>  |
|--|--|--|--|

Recommended separation distances between portable and mobile RF communications equipment and the ME EQUIPMENT and ME SYSTEM – for ME EQUIPMENT and ME SYSTEM that are not LIFE-SUPPORTING.

Recommended separation distances between portable and mobile RF communications equipment and the slit lamp microscope

The slit lamp microscope is intended for use in an electromagnetic environment in which radiated RF disturbances are controlled. The customer or the user of the slit lamp microscope can help prevent electromagnetic interference by maintaining a minimum distance between portable and mobile RF communications equipment (transmitters) and the slit lamp microscope as recommended below, according to the maximum output power of the communications equipment.

| Rated maximum output power of transmitter<br>W | Separation distance according to frequency of transmitter<br>m |   |   |
|--|--|---|---|
|  | 150kHz to 80 MHz   | 80MHz to 800MHz                               | 800MHz to 2.5GHz                            |
|  | $d = \left[ \frac{3.5}{V_1} \right] \sqrt{P}$                  | $d = \left[ \frac{3.5}{E_1} \right] \sqrt{P}$ | $d = \left[ \frac{7}{E_1} \right] \sqrt{P}$ |
| 0.01   | 0.12   | 0.12  | 0.23  |
| 0.1  | 0.37   | 0.37  | 0.73  |
| 1  | 1.2  | 1.2   | 2.3   |
| 10   | 3.7  | 3.7   | 7.3   |
| 100  | 12   | 12  | 23  |



#### WEEE precautions:

Please dispose the waste electrical and electronic equipment in accordance with relevant regulations and laws.

### Installation of the instrument and working condition

Slit lamps are network powered medical instrument. Please check according to the checking list after opening the carton and install the instrument according to this user manual. Test and ensure the instrument operating well before putting to use.

**Component list**

| No. | Component name                      |
|-----|-------------------------------------|
| 1   | 15V/4A DC power adaptor             |
| 2   | Control circuit board               |
| 3   | Brightness adjustment potentiometer |
| 4   | Power switch with indicator         |
| 5   | Photo shooting button               |
| 6   | USB port                            |
| 7   | 3 pin input aviation connector      |
| 8   | 4 pin output aviation connector     |
| 9   | LED bulb as light source            |
| 10  | Diode (for fixation light)          |

**Transport and Storage Environmental Conditions**

No special requirements besides the content about transportation and storage of IEC 60601-1 standard.

# 1 Graphical description of each part of the slit lamp microscope

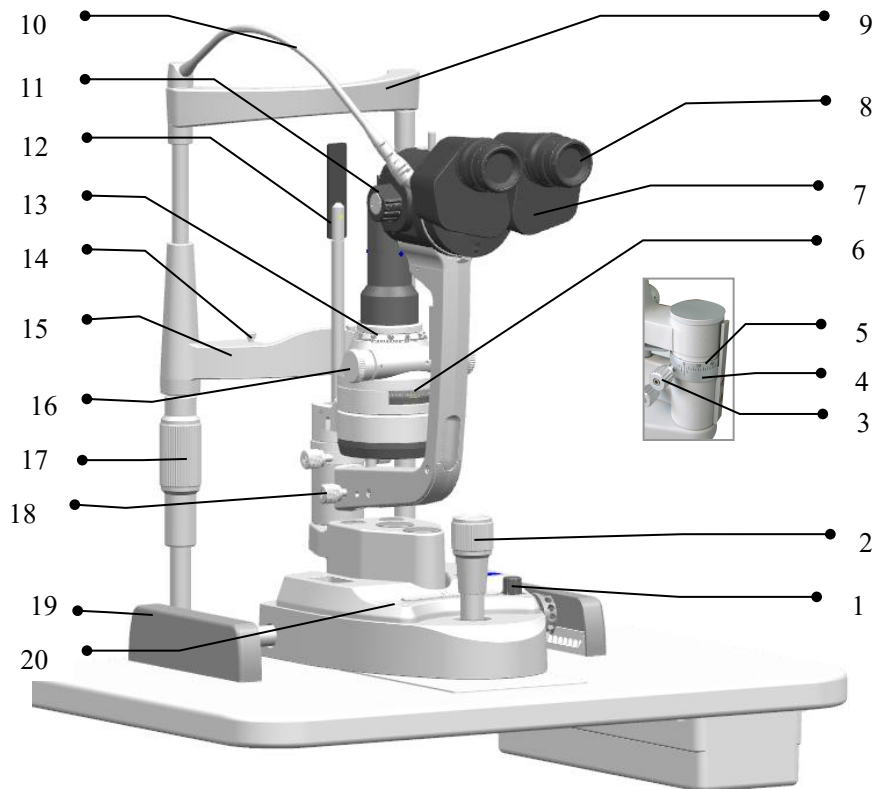

- 1 Brightness Control knob  
The brightness can be adjusted continuously.
- 2 Joystick  
Incline joystick to move the instrument slightly on the horizontal surface and rotate it to adjust the elevation of the microscope.
- 3 Illumination arm locking knob  
When the knob is tightened, the illumination system and the observation system are in a linked state and can rotate together. When the knob is loosened, the illumination system can be rotated separately.
- 4 The indication of relative angle between the microscope and illumination unit.
- 5 The mark of relative angle between the microscope and illumination unit.
- 6 Aperture ring/filter ring  
You can manually turn the aperture ring to select the size of the aperture, and the scale is displayed on the aperture ring.

- You can select the filter by turning the filter ring by hand.
- 7 Binocular tubes base  
Open it to both sides and adjust to the appropriate distance for easy observation.
  - 8 Eyepieces
  - 9 Headrest Belt  
To fix the patient's head on an appropriate position.
  - 10 Fixation target  
Make the patient stare at it, it is convenient for checking.
  - 11 Magnification Changer  
Rotate the changer, to obtain different magnifications for microscope observation.
  - 12 Focusing Testing Rod  
Used to align the microscope focal length.
  - 13 Slit angle indicator  
Rotate the slit part, the slit can rotate angle.
  - 14 Chin-rest paper fixing bolt  
For fixing the pad paper.
  - 15 Chin-rest  
Supporting the patient's chin.
  - 16 Slit Width Control Knob  
Turn the knob to adjust the slit width. The left knob is marked with a slit width indicator.
  - 17 Chin-rest Elevation Adjustment Knob  
Rotate the knob to adjust the elevation of the chin-rest.
  - 18 Microscope arm locking knob  
Lock the observation system so that it cannot rotate.
  - 19 Rail Cover  
Protect the rail surface.
  - 20 Power Switch  
The power switch is equipped with a power indicator light. After the power is turned on, the indicator light will glow to indicate that the power is on.

## 2 Installation

This section of the manual describes how to assemble the slit lamp microscope. All parts should be taken out with great care from the packing case before assembling.

### Warning!

- Do not modify this equipment without the manufacturer's authorization.
- Installation and maintenance can only be carried out by trained specialists.
- Any third-party equipment connection must comply with EN 60601-1 standard.
- Only original parts may be used.
- Grounding reliability can only be achieved when the equipment is connected to a hospital-grade socket. (Not applicable to EU countries).
- The equipment should be set up in such a way that the plug is always accessible and the equipment can be easily disconnected from the mains.

- To avoid the risk of electric shock, this equipment must only be connected to a supply mains with protective earth.

## 2.1 Check List

| No. | Name                 | Qty. |
|-----|----------------------|------|
| 1   | Chin-rest            | 1    |
| 2   | Binocular tubes Part | 1    |
| 3   | Microscope Part      | 1    |
| 4   | Rail Cover           | 1    |
| 5   | Power Cable          | 1    |
| 6   | AC-DC Adaptor        | 1    |
| 7   | Focusing Test Rod    | 1    |
| 8   | Dust-proof Cover     | 1    |
| 9   | Chin-rest Paper      | 1    |
| 10  | 5mm Wrench           | 1    |
| 11  | Gas Shield           | 1    |
| 12  | User Manual          | 1    |
| 13  | Packing list         | 1    |

Table 2

Figures:

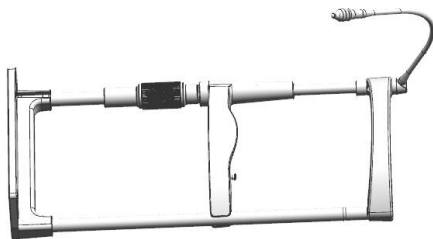

Chin-rest



Binocular tubes Part

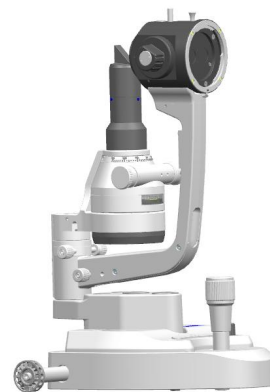

Microscope Part

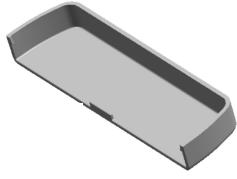

Rail Cover

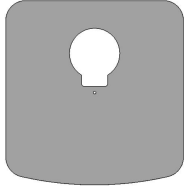

Gas Shield



Focusing Test Rod

## 2.2 Installation procedure

1. Open the carton, take out the tools like screw driver and spanner.
2. Take out the microscope part, put it on the rails of the instrument table, and check whether the wheels can move steadily on the rails, place the rail cover to the rail, remove four screws attached to the rail with the screw driver, retighten the previously removed screws.

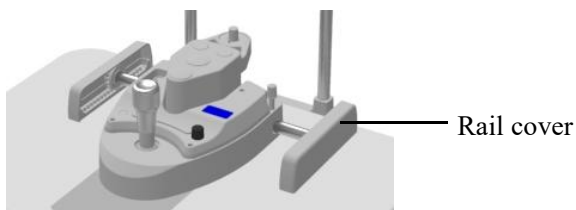
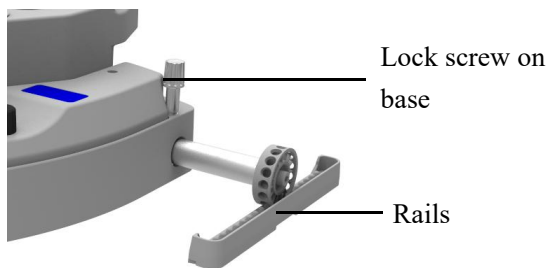

3. Take out the binocular tubes part, put the gas shield on the cylindrical surface of the binocular tubes, and then match the groove on the binocular tubes with the pin on the microscope body. Fasten the fixing screw on the body to the microscope, match the limit groove. **ATTENTION: Don't touch the objective lens and eyepiece when assembling.**

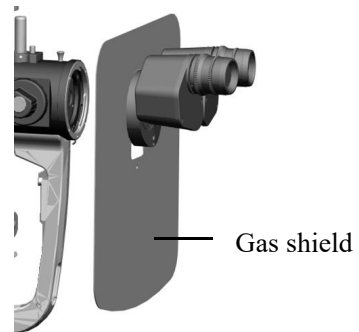
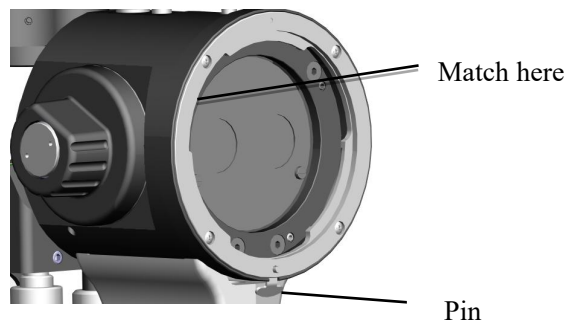
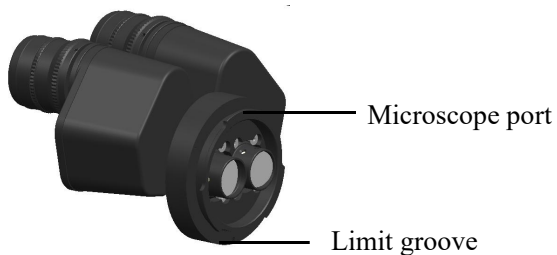

4. Connect with AC outlet power. Use the 4pins male electric connector on the chin-rest set to connect "Output" on the base. Connect the power adapter with "Input" on the base. Please connect the power cable to the outlet AC100V - 240V.

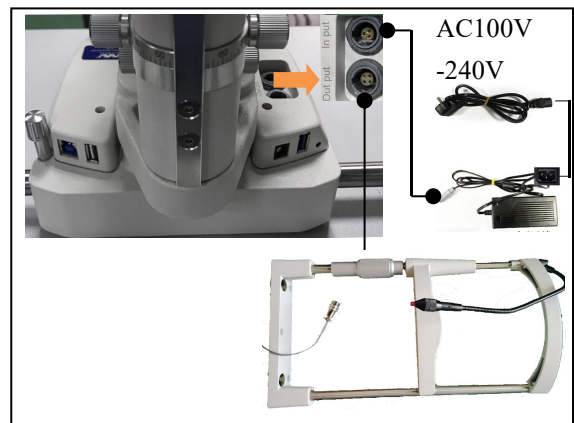

5. Connect with DC 12V power. Please remove the power adapter and connect the cable with the male socket to the outlet DC 12V.

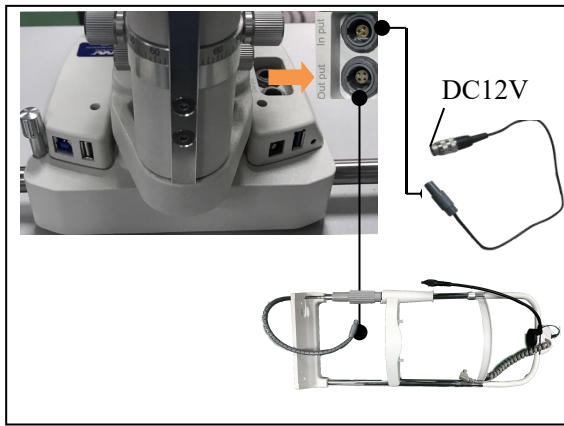

**Note: The limited slot on the air socket should be aligned corresponded slot when plugging and unplugging. Do not force the plug.**

- The power supply can work normally from 100V to 240V. The power switch can be turned on with one short-press, short-pressed again to standby and long press for 3 seconds to turn off all power.

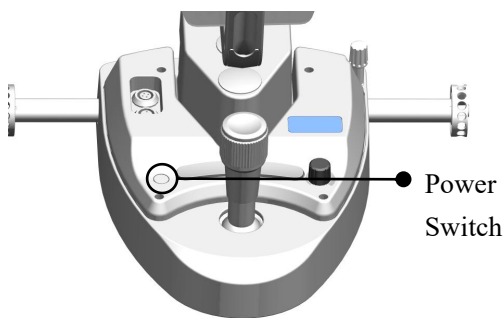

### 2.3 Checking procedure

- The power cord of this instrument is a three-core power cord. Please select a suitable power socket to match it.
- Insert the focusing testing rod, turn the slit width control knob, the illumination spot should be observed on the black plane of the focusing testing rod, and turn the brightness control knob, the illumination brightness should change.

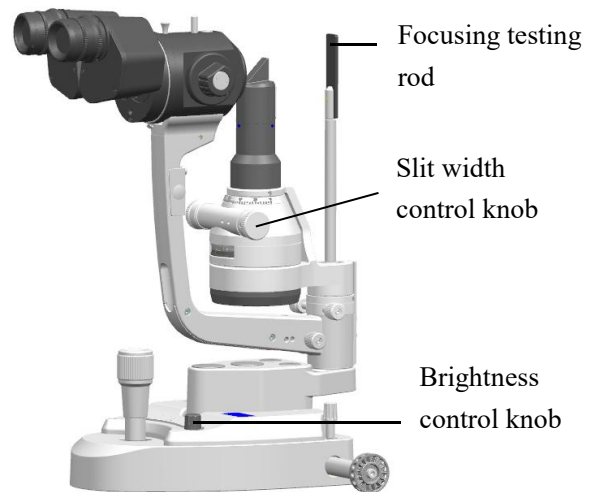

- Check the fixation target to verify that it is properly illuminated.

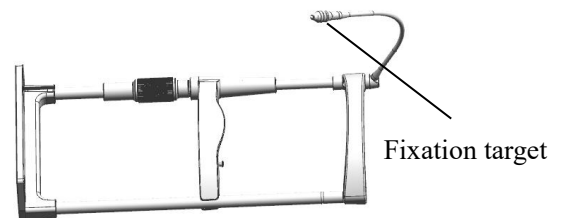

- Check whether the moving parts such as the magnification changer, the aperture ring/filter ring and the joystick operate normally.

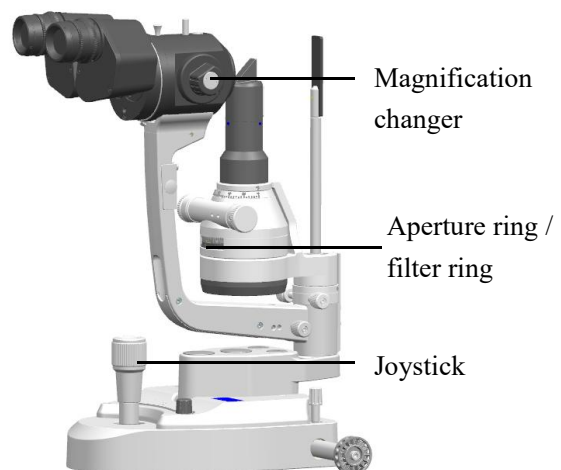

- After the checking is completed, press and hold the power switch for 3 seconds to turn off the power and cover the dust cover.

### 3 Operation procedure

#### 3.1 Diopter compensation and Pupillary distance adjustment

##### ① Focusing test rod

The focusing test rod is provided as a standard accessory to determine the correct adjustment of the microscope. Insert the focusing rod into the spindle hole with the lettering face facing the objective lens of the microscope, i.e. the operator side.

**Note: After adjustment, the focusing test rod should be removed.**

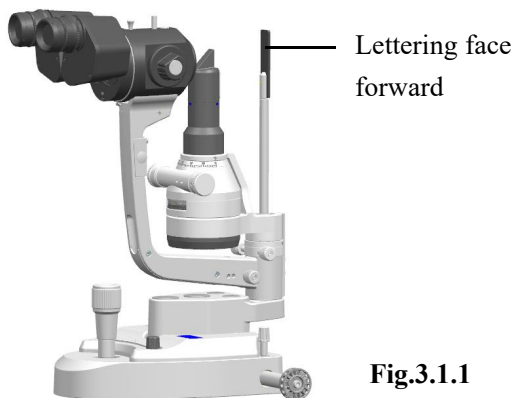

Fig.3.1.1

##### ② Brightness adjustment

Turn on the main power switch and turn the brightness adjustment knob to the middle (see Figure 3.1.2). Adjust the slit width control knob to make the slit width 2 to 3 mm.

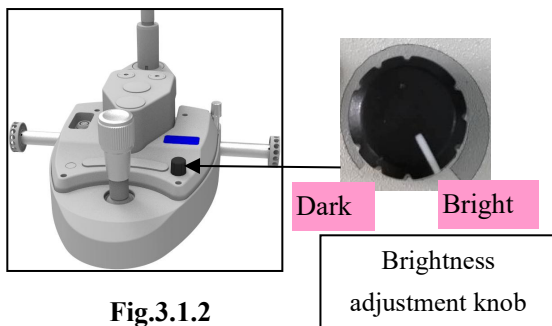
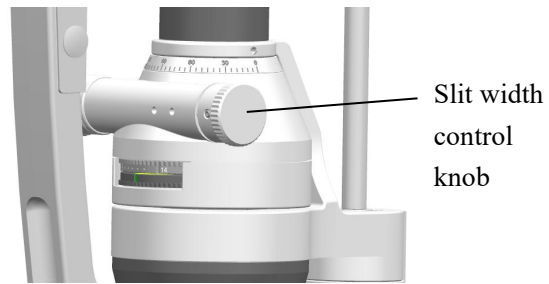

Fig.3.1.2



Slit width control knob

##### ③ Diopter adjustment

The focus of the microscope is adjusted according to the emmetropia (i.e. 0 diopter). If the operator has ametropia, gently rotate the eyepiece tube diopter adjustment ring to adjust the eyepiece diopter to the appropriate position.

It is recommended to correct the diopter in the following order:

First, rotate the diopter adjustment ring counterclockwise to the end;

Then, turn the diopter adjustment ring clockwise until the clearest slit image appears on the focusing test rod;

Adjust the other eyepiece in the same way;

Record the diopter value on each eyepiece for future reference.

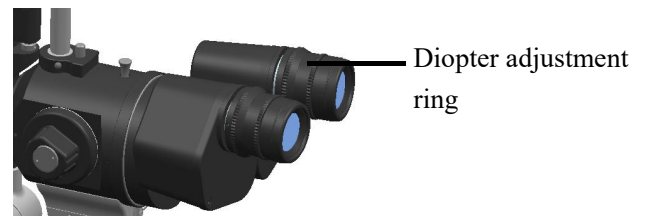

Diopter adjustment ring

##### ④ Pupillary distance adjustment

Use both hands to tilt the binocular tubes base on both sides, adjust the pupil distance to both eyes and observe the image on the focusing test rod through the eyepiece to obtain a stereoscopic image. When adjusting the pupil distance, ensure that the two eyepieces are at the same height.

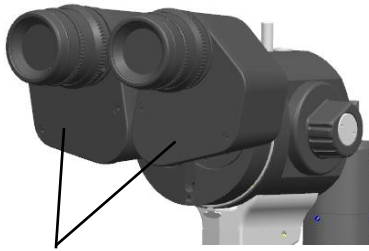

Tilt the binocular tubes base on both sides

### 3.2 Patient's head position and use of fixation target

- ① Place the patient's chin on the chin-rest, with the forehead resting on the headrest belt and adjusting the chin-rest elevation adjustment knob below the chin-rest bracket until the patient's corner of the eye match with the level of the pole marked in line.
- ② The use of the fixation target is to fix the patient's vision, so that the patient's non-examined eye is gazing at the fixation target. When changing the fixation position, turn the fixation rod up and down or left and right to obtain the desired fixation target position.

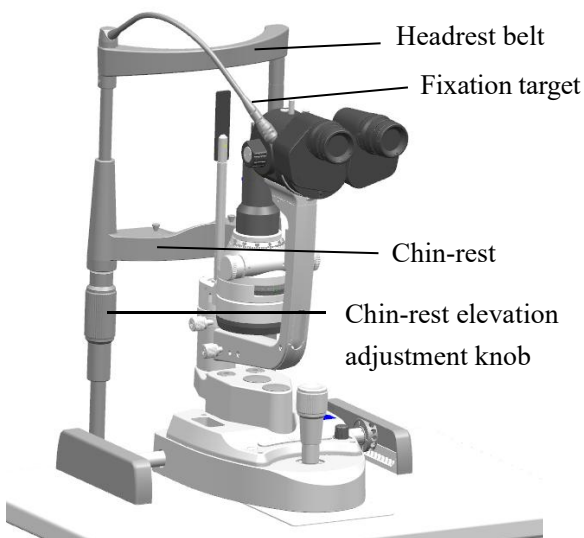

### 3.3 How to use moving base

- ① Roughly Adjustment in the horizontal direction: Keep the joystick in the upright

position (see Figure 3.3.1), move the base back and forth to move the microscope in a horizontal direction to roughly align the target.

- ② Adjustment in the vertical direction: Rotate the joystick to adjust the height of the microscope to align it with the target. Rotate clockwise to raise the microscope; counterclockwise to lower the microscope (see Figure 3.3.1).
- ③ Slightly adjustment in the horizontal direction: Tilt the joystick tilt back and forth to make the microscope move slightly in the horizontal direction. Observe through the eyepiece to accurately align the target to obtain a clear observation (see Figure 3.3.1).

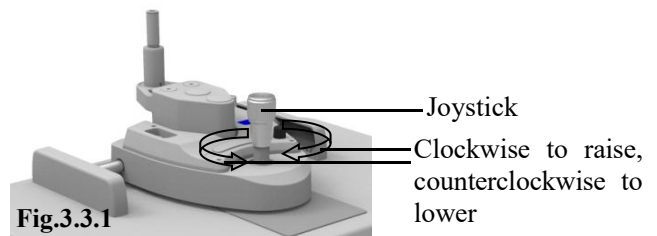

Fig.3.3.1

- ④ Lock the base. After the microscope is adjusted, tighten the base locking screw (see Figure 3.3.2) to fix the base so that it cannot move.

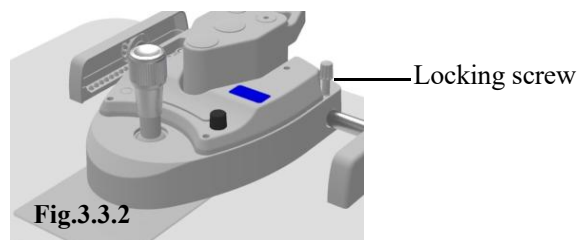
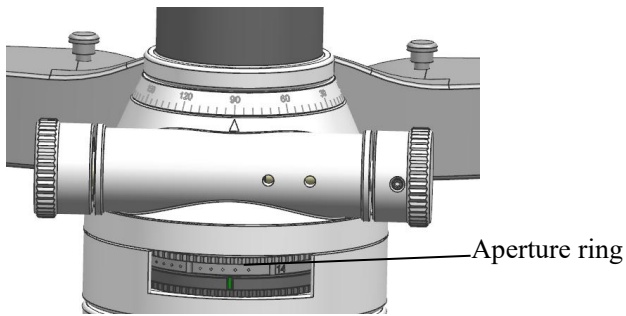

Fig.3.3.2

### 3.4 Operation of illumination system

- ① Change the aperture and the height of the slit: rotating the aperture ring, you can get 4 kinds of circular apertures of different sizes and 1 kind of continuously changing aperture, the diameter of the circular aperture is 14, 8, 3.5, 0.5, The continuously changing light aperture can continuously change the slit length from 1 to 14mm. The aperture data is displayed on

the aperture ring.



- ② Rotating slit image: horizontally move slit angle indicator can rotate the slit image at any angle between vertical and horizontal. The angle of rotation can be displayed by the scale board. Each small grid is 5.

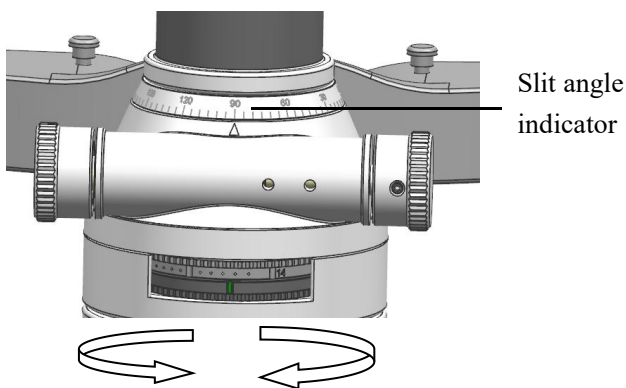

- ③ Select the filter: Rotate the filter ring to switch 3 different color filters into the light path. Heat-absorbing filter is usually used to make the patient feel more comfortable. The other filters should be returned to the position of the heat shield after use.

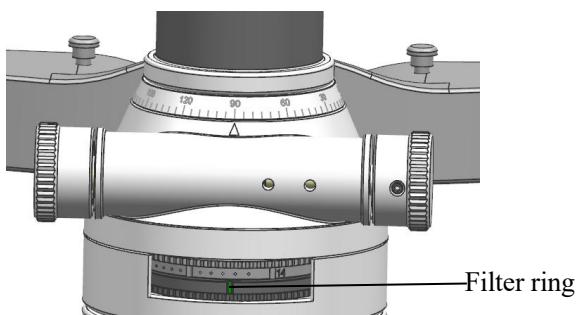

### 3.5 Operation notes

1. During the operation, the operator should first understand the contents of the

instruction manual and master the structure and function of the slit lamp microscope. It is necessary for proper operation and diagnosis. Only in this way can correct operation and diagnosis be carried out.

2. During the use of the operator, the different scales and different indication marks corresponding to the various knobs at different positions should be clearly, to prevent unnecessary misjudgments during observations.
3. The operator should adjust the pupil distance and the vision before observing the microscope during the operation. If the distance and vision are incorrect, there may be a feeling of dizziness.
4. The operator may have a feeling of dizziness if using microscope for a long time during the operation. Please adjust the observation time according to your personal situation.
5. When the patient is diagnosed with a slit lamp microscope, a beam of slit light is applied to the eye. If the slit light is too dark, it will affect the observation. If the slit light is too strong, and the observation last too long, it may affect the patient's vision. If the patient feels uncomfortable, please inform the operator or actively seek medical attention. Try to avoid illuminating the patient's eyes for a long time under strong light.

## 4 Cleaning and maintenance

### 4.1 Cleaning

#### 4.1.1 Cleaning method

- ① Cleaning the lens and mirror: If dust adheres to the lens or mirror, gently wipe it off with soft cotton dampened with absolute alcohol (see Figure 4.1.1).

**Attention: Don't wipe with hands or hard object.**

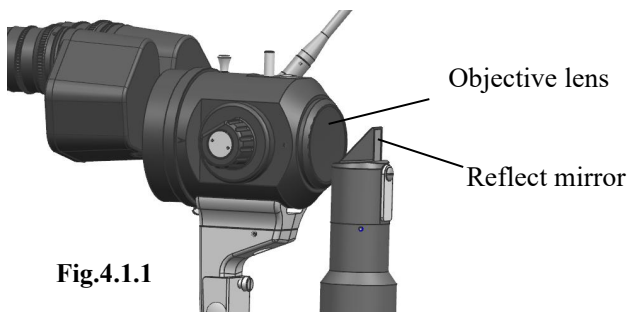

Fig.4.1.1

- ② Cleaning the pad, rails, and shaft: If the pad, rails, and shaft are not clean, the horizontal and vertical movements will not be smooth. Wipe clean with a clean soft cloth (see Figure 4.1.2).

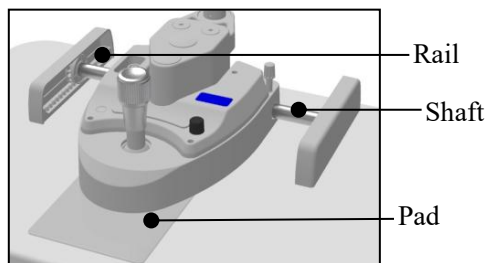

Fig.4.1.2

- ③ Cleaning and disinfecting plastic parts: Clean plastic parts such as chin-rest, headrest belt, etc. Use a soft cloth dampened with a soluble detergent or water to clean the dirt, and then wipe it with medical alcohol. **Note: Do not use any corrosive cleaning agent to wipe, so as not to damage the surface.**

#### 4.1.2 Cleaning cycle

##### ① Cleaning cycle

The slit lamp microscope should be used in a relatively clean environment, and the main parts that need to be cleaned are as specified in the instruction manual 4.1.1. In order to ensure the normal use and observation of the slit lamp, the cleaning should be carried out regularly. The cleaning cycle is recommended as follows:

- a. For the eyepiece area, lens and mirror parts:  
**Cycle:** It is recommended to do it every 2 months.

Since the surface of the lens and the mirror is coated with an anti-reflection film and a reflective film, although the coating is sufficiently strong, frequent wiping tends to cause damage to the film, thereby affecting the optical effect of observation. This cycle is only a suggestion. If there is a lot of dust adhering to the lens that has affected the quality of the observation, it is recommended to clean it immediately according to the prescribed method.

- b. For the rails, shaft and the pad:

**Cycle:** It is recommended to do it once every month.

The use of slit lamps in a relatively clean environment in a hospital does not cause dirties the sliding pad, rails and shafts. They will not need to clean in a short period of time (within 1 year), nor does it affect the horizontal and vertical movement of the moving base. However, we recommend that you clean the above parts with a clean soft cloth every month for better positioning and positioning.

- c. For chin-rest, plastic parts such as headrest belt:

**Cycle:** It is recommended to do it once a day.

These two parts are the parts that are in frequent contact with the inspected person. They should be cleaned and disinfected in time. The cleaning and disinfection cycle is only our recommendation. A new chin-rest paper should be replaced when inspecting each of the inspectors. The headrest strap area should also be cleaned. These two parts should be cleaned and disinfected every day before the first use.

- d. For the whole device

**Cycle:** It is recommended to do it every 2 months.

##### ② Maintenance cycle

Correct and regular maintenance can help to extend the life of the slit lamp. The maintenance cycle of the slit lamp is 2

months. Maintenance should be carried out every 2 months.

③ Product Lifecycle

The slit lamp has a life cycle of 8 years.

**4.2 Protection**

During the use of the slit lamp, dust and dirt are easily trapped in the spindle hole of the arm. To protect the instrument from damage, cover the spindle hole with a protective cover. When the focusing testing rod needs to be installed, the protective cover can be removed (see Figure 4.2.1).

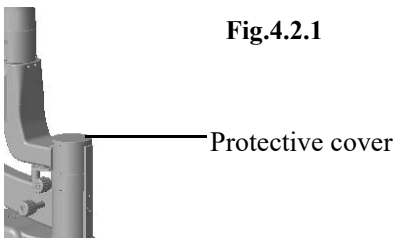
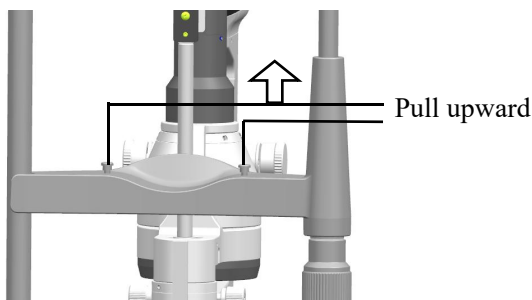

**Fig.4.2.1**

Protective cover

**4.3 Replace the chin-rest paper**

When the chin-rest paper is used up, pull out the two fixing bolts on the bracket and put on the new paper, then install the fixing bolt (see Figure 4.3.1).



**Fig.4.3.1**

**4.4 Rail cover removal instructions**

1. Place your hand on the rail cover.

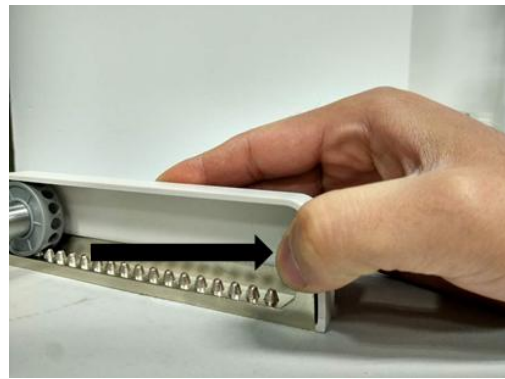

2. Pull the rail cover outwards to see an obvious gap.

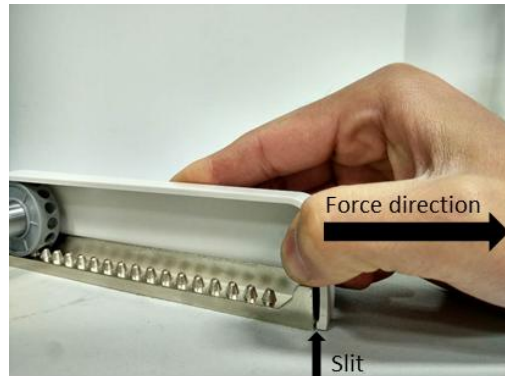

3. Move the rail cover in the direction of the arrow shown.

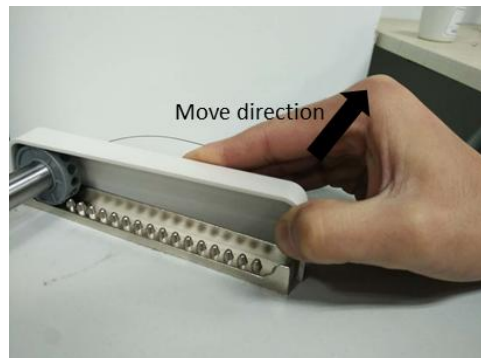

4. If the mid cover area is detached, the disassembly is successful.

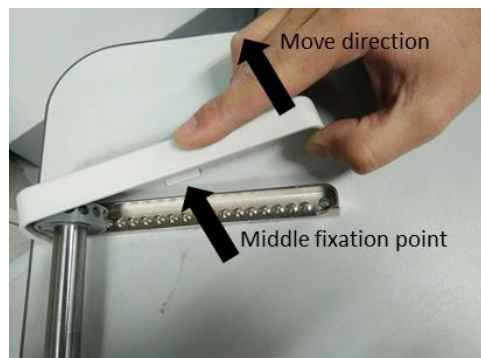

5. The false example one.

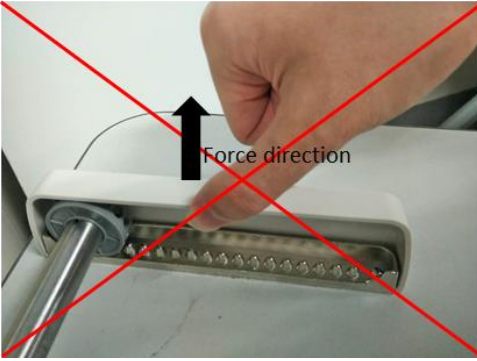

6. The false example one.

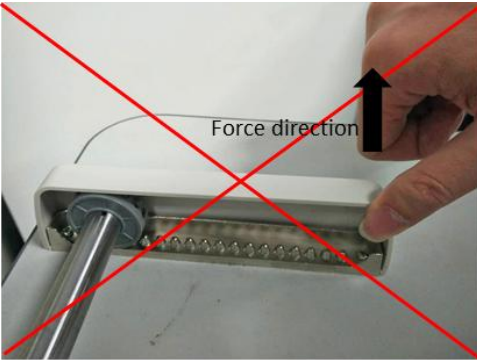

## 5 Trouble shooting

In case there is any trouble, please check according to the following table for reference. If it still cannot work, please contact the after-sales service department of an authorized distributor.

| Trouble                          | Possible Cause  | Solution   |
|----------------------------------|---|--|
| Illumination does not light      | The power cord is not properly connected to the power outlet.           | Connect the power cord correctly.                            |
|                                  | The main power switch is not turned on.                                 | Short press the switch key, the power indicator light is on. |
|                                  | Loose plug on the power adapter.  | Tight plug on the power adapter.                             |
|                                  | The lamp cover is not aligned.  | Tighten the knob.  |
|                                  | Power adapter is damaged.   | Replace the power adapter.                                   |
|                                  | The brightness adjustment knob is in the Min.                           | Adjustment brightness adjustment knob.                       |
| The slit is too dark             | Excessive dust on the eyepiece surface.                                 | Clean the surface with soft cotton.                          |
|                                  | Excessive dust on the reflect mirror surface.                           | Clean the surface with soft cotton.                          |
|                                  | The brightness adjustment knob position is not adjusted to the maximum. | Adjust the brightness adjustment knob.                       |
|                                  | Excessive dust on the objective lens surface.                           | Clean the surface with soft cotton.                          |
| The fixation lamp does not work. | The fixation lamp plug is loose.  | Tight fixed light plug.                                      |

**Subject to change in design or specifications without advance notice**

Version: 6.0

20250425



CMC Medical Devices & Drugs SL  
C/ Horacio Lengo N18, Málaga, 29006, Spain

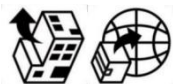

Tomey GmbH  
Wiesbadener Strasse 21, 90427 Nuernberg, Germany



Shanghai MediWorks Precision Instruments Co., Ltd.  
No.7, MingPu Phase II, No.3279 SanLu Road, MinHang District, 201100,  
Shanghai, China