

BIOBASE[®]

**Hand Wheel Vertical Autoclave
BKQ-B50/75/100/120(II)
User Manual**

BIOBASE GROUP

Version 2020.08

Content

1. Installation and Adjustment.....	2
1.1 Check whether the parts is complete.....	2
1.2 Equipment unpacking Installation Preparation.....	2
1.3 Installation and Debug.....	2
2. Equipment use instructions.....	5
2.1 Use instructions.....	5
2.2 Equipment marking instructions.....	5
2.3 Summarize.....	6
2.4 Equipment principle and range of application.....	7
2.5 Control Panel.....	9
2.6 Operation Run.....	13
2.7 Equipment daily maintenance.....	14
3. Common fault and solution.....	18
3.1 This Instruction tries to provide the maintenance method for the known fault, the below are some common faults.....	18
3.2 Alarm Code:.....	18
4. Warranty.....	20
Figure 1: Electrical Schematic Diagram	21
Figure 2: PID Pipeline Schematic.....	22
Figure 3: Vertical sterilizer packing list.....	23

1. Installation and Adjustment

1.1 Check whether the parts is complete

When the arrival of the autoclave, please pay special attention to the packing, carefully check whether the model, product name etc in product packaging box is consistent, and keep the packaging materials. Vertical autoclave packing list (see Appendix 3).

1.2 Equipment unpacking Installation Preparation

1.2.1 Equipment unloading

Before unloading, please note:

Don't stand at the bottom of the hoisting equipment.

Please use the qualified hoisting equipment.

Adjust the hoisting equipment, find the center of gravity, so that making the equipment hoisting horizontally.

Pay attention to personnel safety.

1.2.2 Equipment inspection

After opening the packing box, please carefully check whether the equipment and parts are in good condition, if there are any damage or loss, please kindly make record and contact our company.

After unpacking the equipment, firstly check the model and product name on the product nameplate whether compliance with the order. (Product nameplate is at the rear cover of the equipment)

Whether the equipment has apparently collision trace, whether it is intact, if you have questions, please make record and contact the shipping company or our company.

1.2.3 Handling and moving

The process of installation should be under the guidance of professionals, responsible by professional construction personnel.

Please do not hand wheel carrying mobile autoclave.

When mobile the autoclave, please put the autoclave and control the power disconnect, loosen the castor and carefully moving.

Due to the drainage device at the back of equipment, so please avoid the wall sockets and appliances.

When carrying this equipment, avoid put the autoclave sidelong and backward.

When Install and carry equipment, it should be conducted by professional personnel, handle and put down gently. It is strictly prohibited to severe fall and collide.

In the process of moving, be careful not to damage or scratch outer cover.

1.3 Installation and Debug

Installation steps:

1.3.1 place of autoclave:

Put the vertical autoclave on the ground of the smooth, clean and spacious, adjust the machine feet, make them parallel to the ground, to ensure stable reliable. The distance between back and sides of the sterilizer and other objects at least 250 mm.



Attention: If the sterilizer is clingy wall, may cause internal heat agglomeration of sterilizer and cause failure.

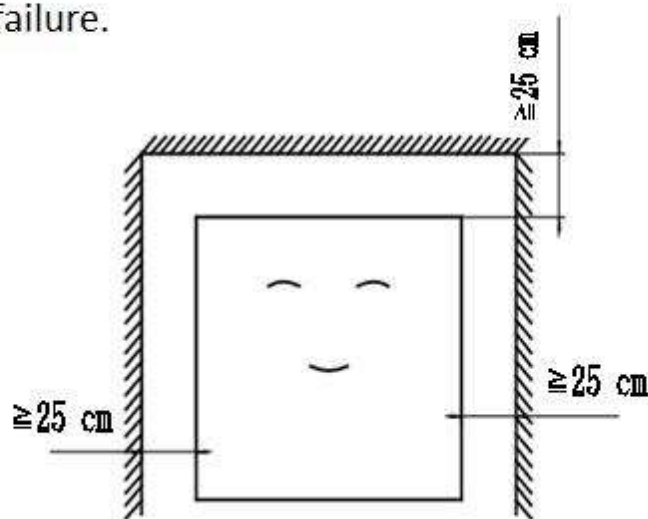

To ensure the ventilation is well.

In addition to keep a safe distance from other objects, the existence of other objects should not affect the equipment operation. When there is a failure in the equipment operation, you should be able to cut off the power quickly !



Attention: Pls let the equipment grounding for your safety.

1.3.2 Power installation

Please install a dedicated connection for wiring devices at the equipment nearby buildings. The height is about 1 meter. (such as circuit power supply and load capacity of the power line should be greater than the rated load of the equipment. Advice:

Single-phase AC 220 v \pm 10% (50 HZ), more than 25 A.

Please don't put equipment in a place which hard to disconnect the power supply, make sure that you can disconnect the power supply in case of an emergency. Please make sure that the fixed socket and power plug of power line with same specification.

Equipment use two phase three wire connection mode, please connect line according to equipment configuration connection way.

Please do not arbitrarily change the connection mode. If you need, please contact us.

Fire wire (L), brown or black; zero line (N) - blue; ground wire (PE) - green and yellow.

Please entrust a specialized electrical construction personnel to do construction work.

To ensure your personal safety, please be sure to lay a ground wire.

1.3.3 Water source required

Devices do not need to connect the water, you need to add water to sterilizer water tank or sterilization chamber manually. You are advised to use soft water or pure water,

Because if use water which is not suitable may shorten the service life of equipment, cause unnecessary trouble. Water quality must meet the following requirements:

Electrical conductivity is less than 15 μ S/cm

The content of bleach is less than 2mg/L.

PH value is 5~7.

Hardness is less than 0.02mmol/L.

1.3.4 Storage Environment

Sterilizer should be stored in a temperature of - 20 °C ~ 55 °C, relative humidity is not more than 80%, indoor or sheltered places which is no corrosive gas and good ventilation.

1.3.5 Working conditions

Sterilizer is required to place in a indoor environment which is clean, dry, avoid light, ventilation,small temperature difference.

The environment temperature 5 °C to 40 °C.

The relative humidity is not more than 85%.

Avoid heavy dust, oil mist, containing conductive particles, corrosive gas, combustible gas environment.

Avoid easily shock or vibration of the occasion.

Avoid high temperature and high humidity or easy to be wet places.

Avoid strong magnetic field environment.

2. Equipment use instructions

2.1 Use instructions

In strict accordance with the instructions of equipment, installation and operation error would endanger the life and property safety of people, and make the generation of manufacturers of equipment performance guarantee is invalid;

In the equipment usage period kept complete instructions for use;

Ensure that all updates received can be preserved in the specification;

In the device using the site or the use of units of change, we must ensure that the instruction for use as part of the overall transfer or transfer equipment.

2.2 Equipment marking instructions



To show should pay great attention



The sign of high water level



The sign of power



The sign of the power input



The sign of opening the door



The sign of low water level

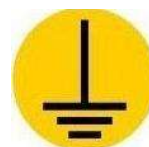

The sign of ground connection



The sign of air circuit breaker

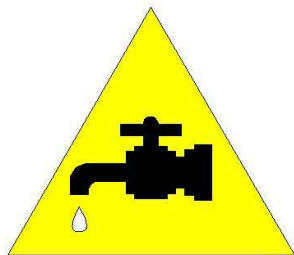

The sign of draining off water



The sign of high temperature

Instructions must be carefully preserved, in case of loss or damage, even a slight damage should be avoided.

The operating personnel have the obligation to repair technology, complete specification, damaged or lost is not suitable, the part of the contents of directories and relevant section.

Any person, not under any circumstances will use any content of the specification are torn or out.

If the experience and instruction for use the instructions in the manual does not match or not relates to the situation, please timely contact with the manufacturers, to upgrade or update.

Manual save to keep ventilation drying, avoid high humidity and temperature.

2.3 Summarize

The product use scope

Applicable to medical and health services, scientific research, agricultural and other units, to the medical equipment, dressings, glassware, solution culture medium to carry out sterilization, also is a necessary test equipment food factory, drinking water plant to do QS, HACCP certification.

Technical parameters

Design pressure: 0.28MPa

Rated working pressure: 0.22MPa

Working temperature: 134 degrees

Source: Deionized water (pure water, distilled water)

Volume: 50/75/100/120L

voltage: 220V

Hygiene license number: (Lu) Xiao Wei card characters (2014) 504th

Design service life: 5 years

Minimum equipment sales unit: 1



注
意

Attention

1. Please open the door after discharging all the steam. Do not close to the sterilizer at the same time
2. The chamber is still keep at high temperature after the sterilizing, please pay attention to insulate the chamber in case of scald.

3. Monitoring method

Methods to monitor sterilization effect including adopting temperature-inspecting sterilization test paper, biological indicator

4. Please avoid the safety valve towards people or other equipment in case of scalding by steam.

2.4 Equipment principle and range of application

BKQ-B series full-automatic vertical autoclave has a microprocessor control system, it can sterilizing at constant temperature steadily. The equipment use LED display, touch button and easy one button operation with a high control accuracy in different ambient temperature, heating power and voltage fluctuation

Model BKQ series autoclave use immersion heating with a high heating efficiency; using saturated steam as working medium to make sure effective sterilization in a short time. The autoclave is surrounded by dry plate so that it can dry the sterilization products effectively.

The equipment is simple and easy to use, it can sterilizer completely, also has a built-in water tank and water and steam circulate inside, also save energy.

It can be used sterilization of medical apparatus, surgical dressing, glassware, rubber products, liquid, ect.

It is widely used in hospitals, testing laboratory, animal husbandry, biomedical research.

The autoclave is Unsuitable for heat and humidity sensitive medical apparatus.

Do not use this equipment for sterilizing oils, power and paraffin.

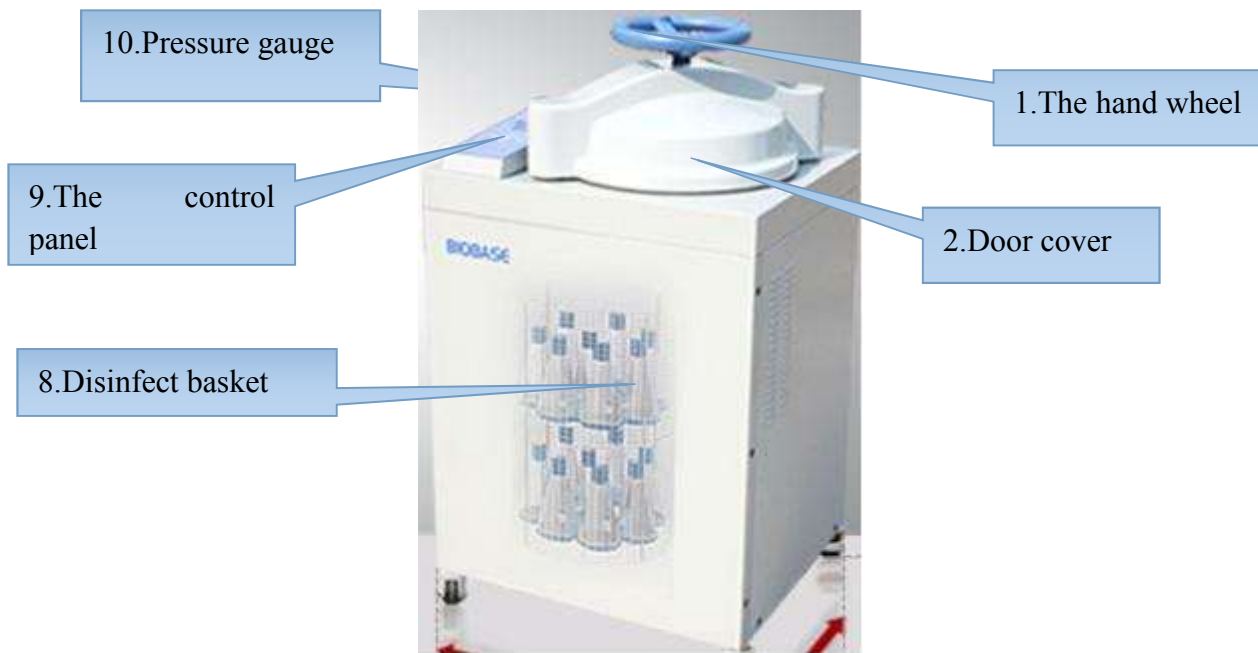

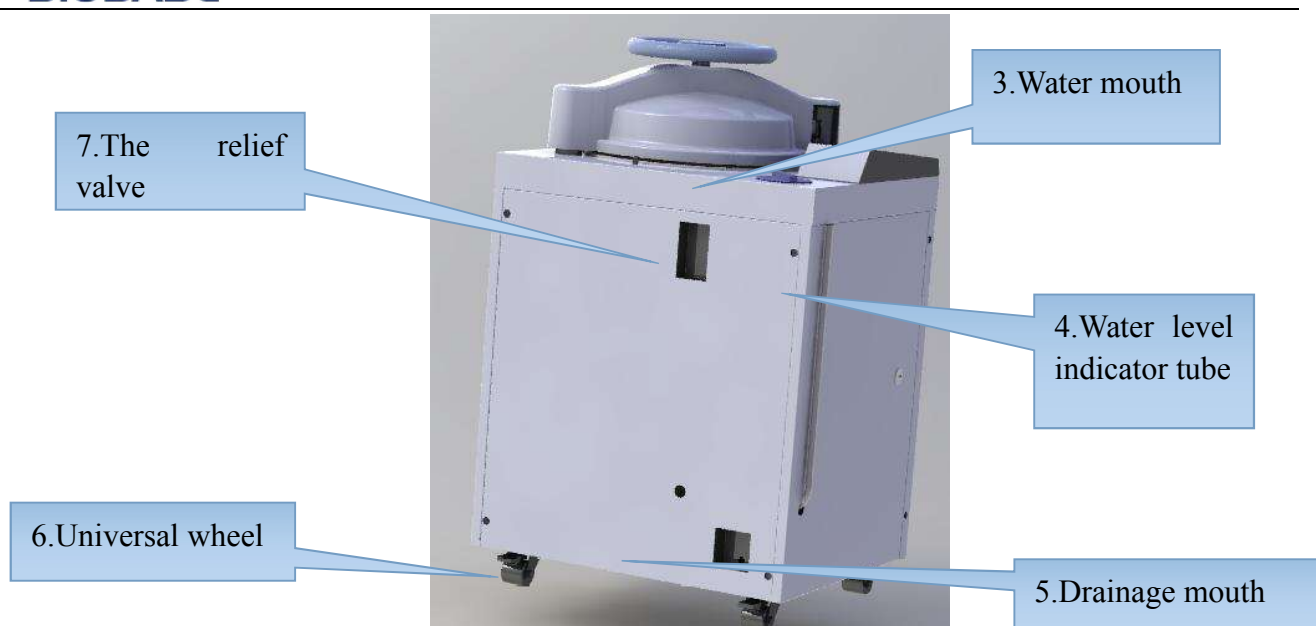

Major function of each device:

NO.	components	Functions
1	The hand wheel	Open or close the door of autoclave
2	Door cover	Heat insulation and protect the operator
3	Water mouth	deionized water is injected from water month to the water tank
4	Water level indicator tube	Indicates water level in the water tank
5	Drainage mouth	Drain the dirty water after cleaning the sterilization
6	Universal wheel	Make the sterilization move smoothly
7	The relief valve	Relief the pressure to make sure the safety
8	Disinfect basket	Load the sterilization articles
9	The control panel	Monitoring the whole sterilization process in real time
10	Pressure gauge	Display pressure in main body when the sterilization is working

Major functions of each device inside sterilization

NO.	Components	Functions
1	water injection solenoid valve	inject water into the sterilization
2	steam exhaust solenoid valve	Exhaust the cold air when warming, exhaust steam and pressure quickly when cooling
3	Safety valve	The safety valve will be open when the pressure reach to 0.26MPa.
4	Air valve	Exhaust cold air, increase degree of saturation, exhaust steam slowly for liquid sterilization
5	water draining solenoid valve	Drain and exhaust to the built-in circulation tank after sterilization
6	sterilizing temperature	

	controller	Drying burning prevention function $\leq 145 \pm 5^{\circ}\text{C} \times$
7	dry temperature controller	Control the temperature of dry heating plate
8	Buzzer	Send the alerting and work end signal
9	Filter	Filter impurities to make the solenoid valve efficiently

2.5 Control Panel

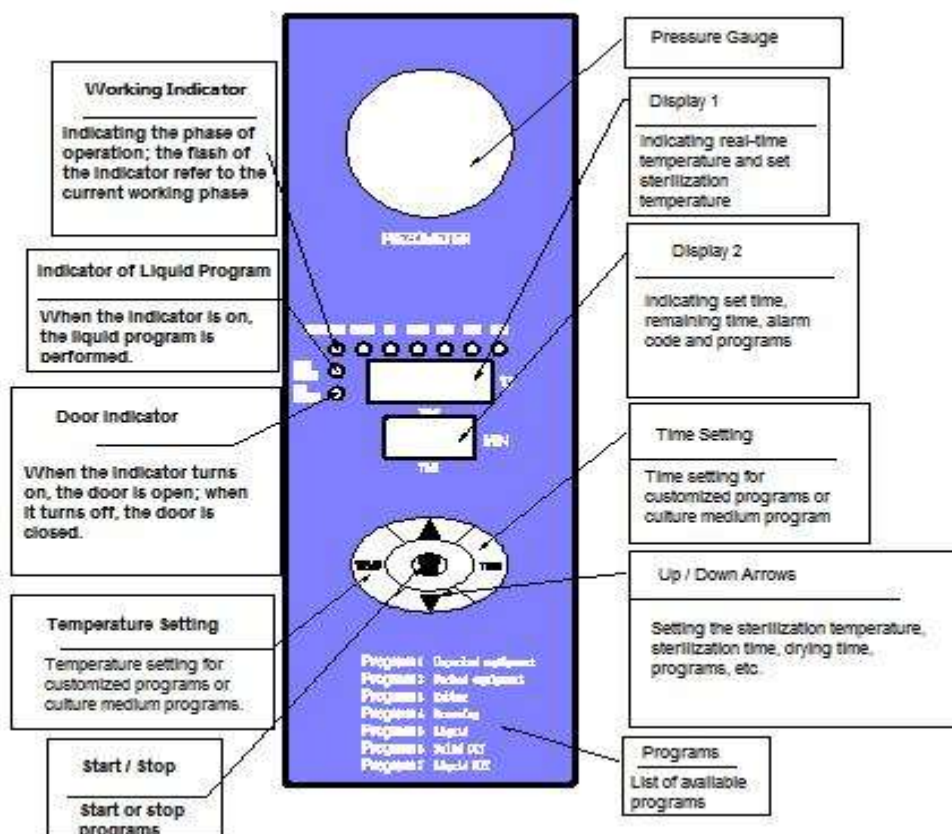

There are 9 sterilization programs:

Sterilization mode/ Program	Times of pulse exhaust	The temp.at which pulse exhaust starts $^{\circ}\text{C}$	The temp.at which pulse exhaust finishes $^{\circ}\text{C}$	Sterilizing temp. $^{\circ}\text{C}$	Sterilizing time(min)	Drying time (min)	Heat retaining time(min)
1#Apparatus	1	Sterilizing temp. -2.5	The temp.at which pulse exhaust starts-5	134	4	5	0
2#Apparatus bag	2	Sterilizing temp. -2.5	The temp.at which pulse exhaust starts-5	134	8	10	0

3#Cloth	3	Sterilizing temp. -2.5	The temp.at which pulse exhaust starts-5	134	12	18	0
4#Rubber	2	Sterilizing temp. -2.5	The temp.at which pulse exhaust starts-5	121	25	10	0
5#Liquid	0	—	—	121	20		0
6#Solid (Customize)	0-9	Sterilizing temp. -2.5	The temp.at which pulse exhaust starts-5	105 ~ 136 (134)	(0-999)	0 ~ 99.0	0
7#Liquid (Customize)	0	—		105 ~ 136 (134)	(0-999)		0
Close the air discharge valve	Local pressure-2℃(Default 98℃); Setting from(80-110℃)				<p>Note:</p> <p>a. Parameters can be set except for the fixed ones. Drying phase starts when the time limit of 4 min for water discharge exhausts or the temp. drops to 100℃.</p> <p>b. Water is discharged when the temp. drops to 105~110℃. When the temp. dropping to 80℃, alarm rings notifying : “sterilization completed, please open the door”</p>		
Water discharge setting	Water discharge (open/close) after the sterilization can be set freely; Temp. of water discharged (Default: discharging when the temp. of water drops to 105℃) Range: 6#Solid (Customize) 105~134℃; 7#Liquid (Customize):105-110℃						
Attention:	The maximum temp. of air and water discharge can not exceed the sterilizing temp.						

Introduction to the control panel:

There are five buttons: “Temp.”, “Time”, “▲”, ”▼” and “Start/Stop”; 9 indicator lights: “Add water”, “Temp. rising”, “Sterilizing”, “Air discharge”, “Drying”, “Finish”, “Alarm”, “Liquid” and “Door”; and “Temp. display” and “Time display”.

Operating procedure:

Plug in, switch on the air switch on the left, and then turn on the rocker switch on the panel. The panel lights on, the autoclave stands by. “Temp. diaplay” shows the word, “Prog”. “Time display” shows number X (X is the number from 1 to 7) which refers to the chosen program. Then “Time display” alternately shows the current temp. and the set sterilizing time.

Choose different programs by pressing “▲”and“▼”. When the fifth program, 5#Liquid, is chosen, the light “Liquid” is on. When the seventh program, 7#Liquid (Customize) is chosen, the light,

“Liquid”, flashes, indicating users that the current phase is “Liquid”-related. Then press “Start/Stop” to start the sterilization.

After sterilization is complete, the "Finish" light, buzzer beep every 10 seconds."Finish" lights, the end of this sterilization, then confirm the gauge pointer back to zero, counter-clockwise on the lid hand-wheel, open the lid, and remove the items.

Note:

If you want to terminate the process of sterilization, you can press the "Start / End" button to terminate the sterilization process.

Custom programs can set sterilization temperature and sterilization time:

Choose Program 6# or 7# first, then set as below.

Sterilization temperature settings:

Press the "temperature" button, temperature display window shows the set temperature and flashes. Through the "▲", "▼" to turn up and down the temperature, and then press "temperature" button once to save the temperature set value.

Sterilization time setting:

Press the "Time" button, the time display window shows the set value and flashes, by "▲", "▼" to change the time set value, then press "time" button once to save the set value.

Parameter setting:

Press the "Start / Stop" and "temperature" button both for 5 seconds to enter the menu.

Display "iwti" represents the time to add water(unit/minute), when press the "Start / End" , the button shows the value and flashes. Through "▲", "▼" to change the value, press "Start / End" to confirm.

Must be 0 displayed "iwti", press the "▼", "EATE" displayed, and press the "▲", "tErF" displayed . "EATE" represents the cooling end temperature, press the "Start / Stop", the button displays the value and flashes, through the "▲", "▼" to change value, then press the "start / stop" to confirm. The default setting is 100.0 °C

When "EATE" displayed, press the "▼", "EATi" showed, press the "▲", "iwti" showed.

Display "EATi" said the cooling time, in minutes. Press the "Start / End" , the button shows the value and flashes , through "▲", "▼" to change value. Then press "Start / End" to confirm. The default setting is 30 minutes. (After the cooling, the temperature can't below the set cooling end temperature, otherwise it will error, if the pot temperature exceeds 105 degrees, the next step will go directly)

After displaying "EATi", press the "▼", "EWTi" will show. Press the "▲", "EATE" will show.

Display "EWTi" said the drainage time, in seconds, press the "Start / End", shows the value and the button flashes, through "▲", "▼" to change the value, then press "Start / End" to confirm. Only solid is program effective, the default is 240 seconds.

After displaying "EWTi", press the "▼", "PULS" shows up, if press "▲", "EATi" after.

Display "PULS" said the sterilization pulsation frequency, in seconds, press the "Start / End", then shows the value and flashes, through "▲", "▼" to change the value, and press "Start / End" to confirm. Only custom solid class program effectively, default 0.

After displaying "PULS", press the "▼", "drti" displayed, if press "▲", "EWTi" after.

Display "drti" said the drying time, in minutes, press the "Start / End", then shows the value and flashes, through "▲", "▼" to change value, press "Start / End" to confirm. Only custom solid program valid, default is 10.

After displaying "drti", press the "▼", "tEFA" displayed, if press "▲", "ESTi" after.

Display "tEFA" indicates the temperature calibration factor, press the "Start / End", then shows the value and flashes, through "▲", "▼" to change value, press "start / end" to confirm, and users are strictly prohibited to modify.

When displaying "tEFA", press the "▼", "tErF" displayed, if press "▲", "drti" displayed.

Display "tErF" indicates the temperature deviation, press the "Start / End", then shows the value and flashes, through "▲", "▼" to change value, press "start / end" to confirm, users are strictly prohibited to modify.

After displaying "tErF", press the "▼", "iwti" shows up, after pressing the "▲", "tEFA" shows up, so as the cycle.

After the parameter modification is complete, press the "Start / End" and "temperature" button both for 5 seconds to save the parameters and exit the menu.

Production debugging, temperature sensor calibration:

First measurement is at cryogenic temperatures (10-30) (can be replaced with an analog temperature sensor) to record the actual temperature T1, and temperature displayed is D1.

Then measurement at the high temperature (100-130) (can be replaced with an analog temperature sensor) to record the actual temperature T2, D2 shows the temperature displayed

Result $(T2-T1) / (D2-D1)$ multiplies parameter K displayed on tEFA menu is obtained a new parameter

After modifying the parameters in tEFA, then according to the temperature difference between D3(the temperature displayed on the temperature sensor) and T2 to modify the parameters in tErF , if the displayed temperature is low, then the value in tErF plus the temperature difference, if the displayed temperature is high, the value in the tErF subtracts the difference.

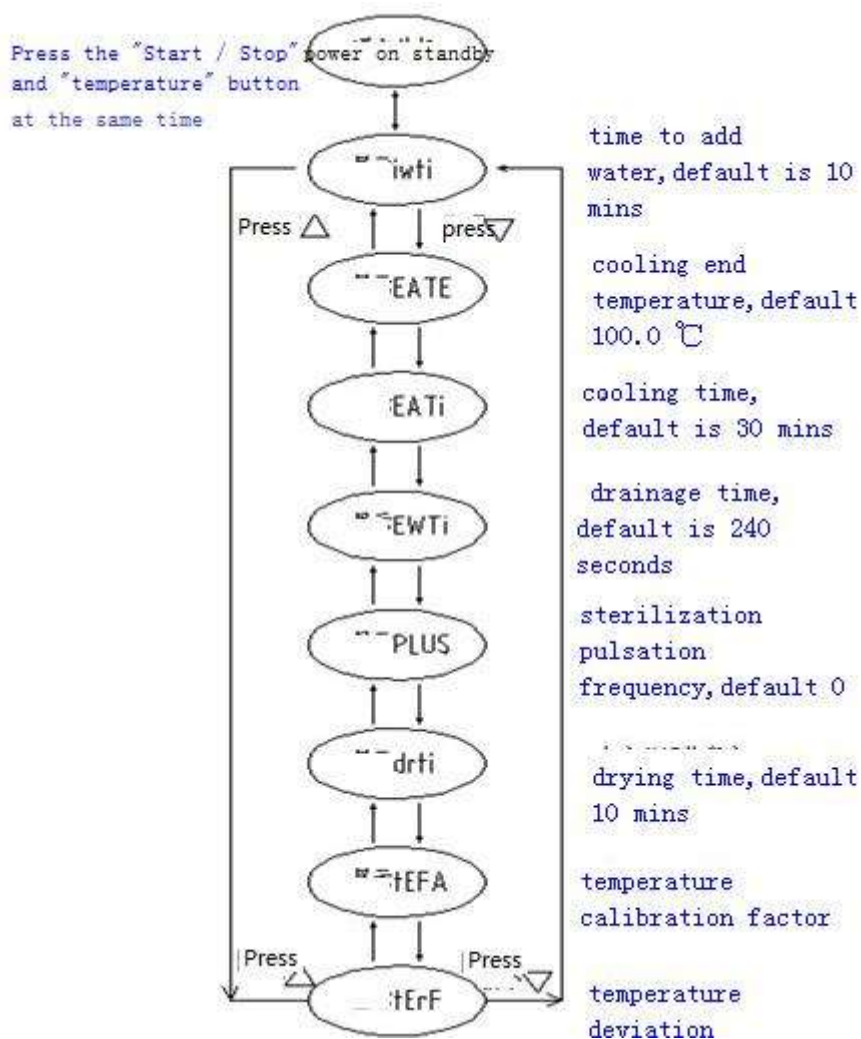

2.6 Operation Run

Sterilizer operating procedures, include sterilization preparation, sterilization items loading, sterilization, sterile unloading procedure.

2.6.1. Sterilization preparation

(1) Cleaning: article should be thoroughly cleaned before sterilization, avoiding the presence of blood and other impurities, as these substances would harm sterilizing articles and sterilizer. After washing, items should be timely dried and packaged.

(2) Packaging: For packaging materials, please use beneficial internal air exhaust and steam penetration packaging materials, strictly complying to "Disinfection technical specifications" and the relevant national standards. The following points may be beneficial to your sterilization effect:

- ① plate, pots, bowls and other containers, as a single package, and the lid is opened.
- ② surgical instruments should be placed in a basket or perforated plate for supporting the package.
- ③ items must be exposed, when the stack release, utensils should be used between moisture cloth, gauze or medical absorbent paper separated.
- ④ surface should be exposed to the various items, in order to facilitate access to all articles factor sterilizing surfaces with mesh containers should be opening down or on its side.
- ⑤ items should not be tied too tight

⑥ equipment package weight was no more than 7 kg, the weight of the fabric bag should not exceed 5 kg. Volume sterilization package should not exceed 30cm*30cm*25cm. 30cm× 30cm× 25cm.



Attention

Packaging materials include rigid containers, disposable medical crepe paper, paper bags, paper bags textiles, non-wovens, etc., should meet the requirements of GB / T19633 in. Textiles should also meet the following requirements: Non-bleaching textiles; cloth seamless addition to the four sides; hot wash before first use should skim to pulp, to color; should use records.

2.6.2 Items loading sterilized items please follow the requirements for loading:

- ① When the items put in, up and down should be a certain distance from each other, items can not be posted near the door and walls to prevent inhalation of more condensate.
- ② similar materials and sterilization equipment and items should be placed together; the material is not the same textile items placed in the upper, heel, metal instruments placed in the lower class.
- ③ surgical instruments package, rigid containers should be flat; pots, bowls items should be diagonal, the package contents openings toward consensus; glass beakers, flasks, test tubes and other bottom nonporous containers open class items should be placed down.
- ④ recommend using a dedicated configuration sterilization and loading rack and basket items.
- ⑤ Gap should be left between the sterile package, which will help the penetration factor sterilization.
- ⑥ large package of difficult sterilization should be placed in the upper , the smaller packet should be placed on the lower deck.
- ⑦ sterilizer loading volume shall not exceed 80%.
- ⑧ only liquid bottles and tubes with the heat load, the load should not exceed the amount of container volume

2.7 Equipment daily maintenance



Attention : must disconnect the power before you use the machine and make sure there is no pressure

To ensure that the sterilizer is in good working condition, and minimize the number of failures, therefore, the operation described in this chapter must be followed.

Before starting maintenance, make sure the device is powered down. At the same time, no pressure in sterile containers.

After the end of the working day with a soft cloth or a piece of gauze to wipe the door gasket.

Remove the basket.

With gauze with a detergent and water, wipe the inner wall of the sterilization container. Do not use steel slag wool or steel brush to avoid damaging the sterilization chamber wall.

Cleaning and sterilizing the container chamber to remove scale. The water in the tank let go.

Weekly

Once a week, to door sales plus molybdenum disulfide grease.

Once a week, with a soft cloth to wipe the sterilizer housing.

Once a week to clean the filter plug.

Once a week, check the steam air exhaust valve.

Once a week, check valve.

Periodic inspection

Once a year, tightening fittings and detection-off state, should be completed by a professional electrician.

Once, due to extreme wear and tear, lock device must be checked every five years.

Instructions: This repair manual is to provide professionals. Unless you are a professional, otherwise when the equipment fails, be sure to consult the instructions and press the manual for repair.

Instructions have been possible to provide professional maintenance methods.

2.7.1 Changing the water tank

1) Remove the transparent silicone tube can drain until the water tank drain.

2) the distilled water into the tank, the water level the water level should, between the maximum and minimum water.

2.7.2 Exhaust steam valve cleaning steps:

Before you begin, you should cut off the power supply and ensure that no pressure inside the sterilization chamber

1) Remove the tank lid.

2) by stretching before and after steam escape valve, flush valve orifice steam escape.

3) If it is necessary to replace the steam escape valve, before replacing, to wait for equipment cooling, the pressure drops to 0MPa.

2.7.3 Checking the safety valve

It is located above the rear.

Safety valve in order to prevent the blockade state, under normal use, every two months, so that steam pressure is released through it once.

1) According to the manual, sterilized operation.

2) the pressure generated inside the sterilization container 0.21MPa.

3) Use a screwdriver to push the safety valve handle, resulting in it is open, about 2 seconds.

4) Turn off the main switch, the operation is terminated. Meanwhile, within the discharge vessel steam sterilization.

5) until the pressure drop is 0MPa time before opening the door.

2.7.4 How to replace the safety valve

Instructions: The only professional repair methods can be used. Unless you are a professional talent, otherwise avoid electric shock, equipment malfunction, be sure to consult the instructions and press the manual for repair, while the specification has been possible to provide professional maintenance methods.

1) It is located above the rear.

2) Remove the valve mounting screws, remove the valve from the valve base.

3) with a qualified safety valve to replace it. Test the sterilization process.

2.7.5 Thermostat

Located inside the device. Sterilizer is equipped with a thermostat. In the heating and sterilization phases, it can be turned with the cut off the power supply to maintain a constant temperature. Typically used as a temperature alarm device.

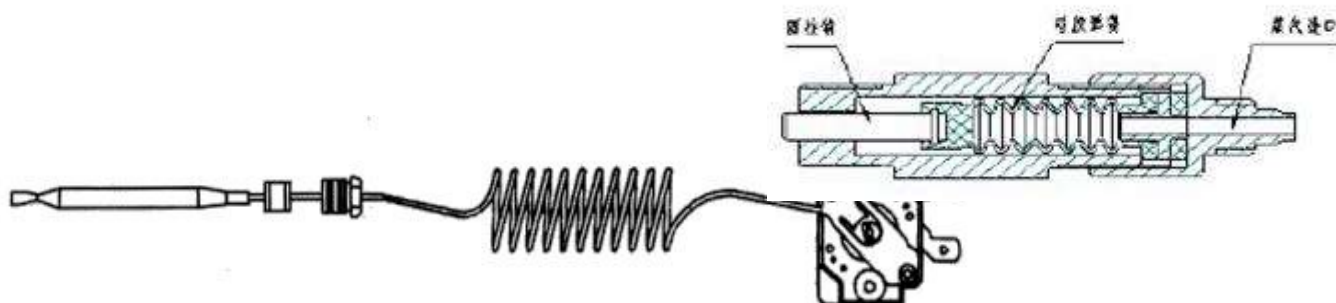

If the pot temperature exceeds the allowable value, the thermostat automatically disconnect the heater power.

When the pot temperature dropped below the allowable value, the thermostat automatically turns on.

2.7.6 How to improve the operating temperature of the thermostat

This operation is limited to professionals.

Use a screwdriver to rotate the center screw clockwise slightly, so that the temperature rise.

2.7.7 Replace the heater step

Before this operation, you should turn off the power, and make sure no pressure inside the sterilization chamber.

- 1) Remove the cover sterilization.
- 3) Remove the wiring heater.
- 3) Loosen the screws on the heater.
- 4) with a new heater to replace the damaged heater, where the new heater must be replaced with the consistent position of the heater and wiring.
- 5) Install the sterilizer housing.

2.7.8 Door Safety Interlock

It is a safety device to prevent the door opening

when the autoclave is under pressure. This system is established on the basis that the inner chamber generate pressure. The pressure generated will push the active clutch up to mesh with the fixed clutch. It will prevent the operator opening the door by mistake. When water vapor have been released, the device will return to the initial position, then the door can be opened.

2.7.9 Filter Cleaning

Located at the bottom of the device, the filter is used to filter out the impurities, ensuring pipeline smoothness and electromagnetic valve leak proof. Screw out filter nut from the chassis of device, remove and clean the filter center. It need to be cleaned once a month approximately



2.7.10 Cleaning steps of electromagnetic valve

- 1) remove the cover of the autoclave
- 2) Pull out the stainless press slip on the electrical magnetic valve with a screwdriver.
- 3) lift the electromagnetic valve coil
- 4) open the valve body with a spanner.
- 5) clean sundries on the valve center with clean water .
- 6) re-install the electromagnetic valve.

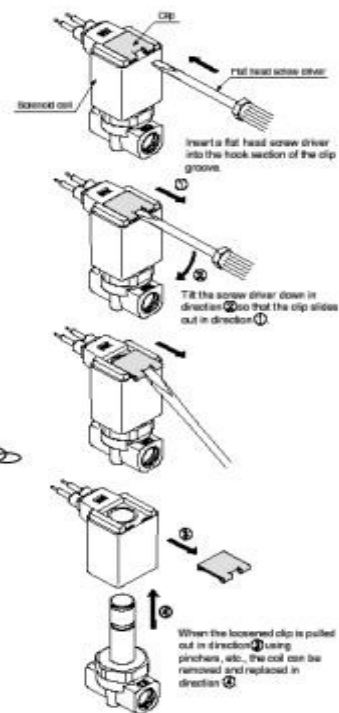

3. Common fault and solution

3.1 This Instruction tries to provide the maintenance method for the known fault, the below are some common faults.

Phenomena	Possible reasons	Correct Operation
Power switch is on, power light is not bright.	1.The circuit breaker is unclosed 2.The main power switch is damaged	1.Close the circuit breaker 2.Change power switch in accordance of specific conditions
The door indicator light is not bright	1.The door is not fully closed 2.The door's micro-switch loose, misplace	1.Try again after fastening the door 2.Adjust the door position switch
Under the condition of warming, Pressure and temperature do not rise, or rise slowly	1.Control circuit of the heater shorts out or burns down 2.pipe joint or safety valve leaks seriously	1.Check and change the damaged elements 2.check, tighten the pipe joint, safety valve, etc
Under the condition of drainage, Pressure and temperature do not drop, or drop slowly	Drain Filter clogs	Clear up the sundries on the filter valve core
Fail to reach the sterilization temperature	Whether determined by the boiling point of the altitude. Please check the set temperature of the boiling point	If not the reason of the altitude, please contact us or our distributor
Safety Valve opens	1.Whether the pressure is too high? 2.Whether the safety valve breaks down	1.Adjust temperature departure 2. Adjust and change safety valve
Steam leaking	1.Whether door rubber gasket become hard and aged 2.Whether the door strip cracks 3.Whether door rubber gasket falls off	1. should change door rubber gasket 2.should change door rubber gasket 3. re-install door rubber gasket

3.2 Alarm Code:

When an error occurs during use, it shows the error code and the buzzer sounds and indicates alarm, the sterilizer automatically stop moving, please look up the following conditions and deal with them.

The failure code list		
Failure code	Condition of the failure	Failure reason
Err 001	It doesn't reach the set temperature after 30 minute's of pulsation exhaust air conditioning.	The heater pipe is broken, have leakage phenomenon.
Err 002	It doesn't reach the set temperature in the exhaust air conditioning or the failure pulsation in duct	The heater pipe is broken. Improper set parameters
Err 04	During the sterilization, temperature fluctuates too large	air leaking
Err 08	The sensor improperly connected or damaged, the temperature in the pot is below 10%	replace the sensor
Err 016	The failure of circuit board temperature measuring component.	Replace control board
Err 032	Not add enough water during the set time of adding water.	Water shortage in the tank, water float broken, failure of solenoid valve
Err 064	The water shortage in the pot caused heating pipe burned	Float failure, after the heating pipe cool down, add enough water to the pot
Err 128	After starting sterilization, the pan is opened	excessive pressure, the pot shifts, pot test failure
Err 256	There is enough water in the chamber	Drain out all water,press Start button and Temp button to remove the alarm.

4. Warranty

To our distinguished guests: Any product has the possibility of failure, please monitor the work of the equipment in real time during use, If any abnormal, please first refer to the manual for processing, If the problem still cannot be solved, you shall inform our Customer Service Centre, to protect against loss.

After-sales service

1. From the day when the equipment is sold(subject to the invoice), one-year maintenance free of charge and all-life services.
- 2.The warranty card: When you need to normal consultation or maintenance, please contact to our after-sales service centers with the warranty card and the invoice, the warranty card must be well kept.

Figure 1: Electrical Schematic Diagram

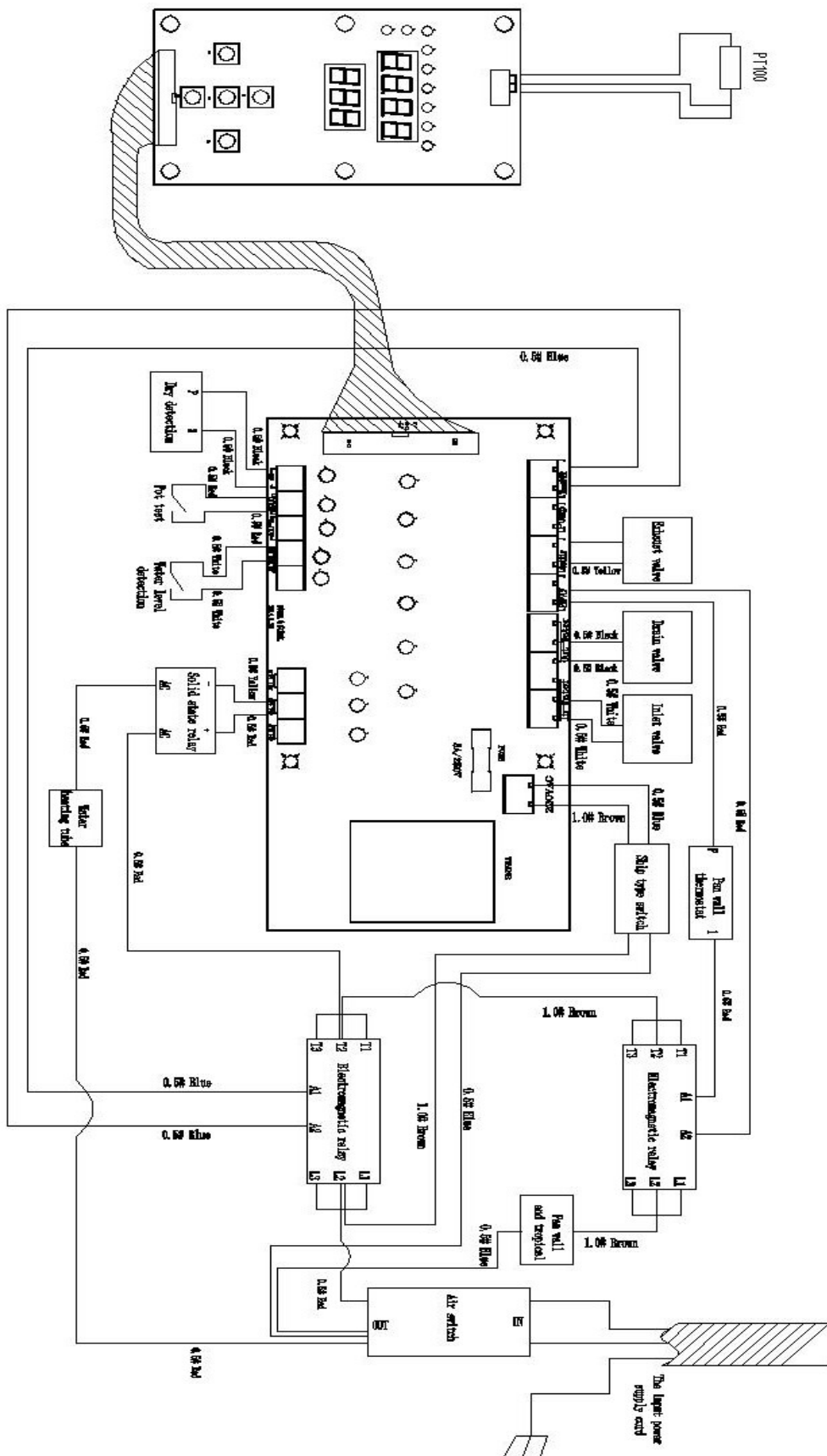
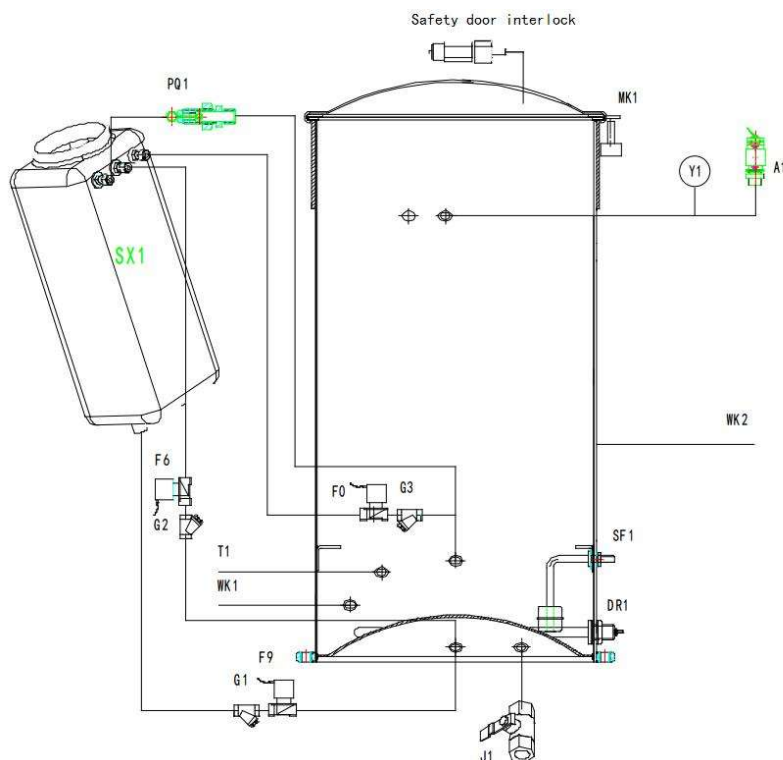

Figure 2: PID Pipeline Schematic



序号	名称
F6	Water injection solenoid valve
F9	Drainage solenoid valve
F0	Exhaust solenoid valve
J1	Drain valves
T1	Platinum water ball valve
WK1	Thermostat
WK2	Pan wall thermostat
Y1	Pressure gauge
A1	The relief valve
G1	Water injection filters
G2	Drainage filters
G3	Exhaust filters
MK1	Micro switch
SF1	The water level float
PQ1	Vent screw (可选)
DR1	Electric heat pipe (可选)
SX1	The water tank (可选)

Figure 3: Vertical sterilizer packing list

Serial Number	Description	Quantity	Notes
1	Equipment	1	
2	Operating instruction	1	
3	Pressure vessel Quality certificates	1	
4	The warranty card	1	
5	Conformity certificate	1	
6	Mesh basket	1	
7	Water fender	1	
8	Tank lid	1	
9	Seal ring	1	
10	Drain pipe	1	

BIOBASE GROUP

2# building, No.9 Gangxing Road, High-tech Zone, Jinan City, Shandong Province,
China

Tel: +86-531-81219803/01

Fax: +86-531-81219804

Inquiry: export@biobase.com

Complaints: customer_support@biobase.cc

After-sales service: service_sd@biobase.cc; service_ivd@biobase.cc

Web: www.biobase.cc/www.meihuatrade.com / www.biobase.com