



Encho Enchev - ETE Ltd.

Bulgaria, 5130 Dolna Oryahovitsa, 25 Dimitar Blagoev St
Tel: +359 6173 22 72; Mob: +359 882 279 759; +359 882 277 414
www.etebg.net ; e-mail: sales@etebg.net



Digitally signed by Medvedcova Renata
Date: 2024.05.22 14:19:32 EEST
Reason: MoldSign Signature
Location: Moldova



TECHNICAL SPECIFICATION

of

Concrete products from high-performance concrete - elements for
landscaping streets, parks and gardens

Product - Concrete bench Model 2





1. Description of the product

1.1 General description of the product:

Backrest bench made of high-performance concrete, natural mosaic and certified wood. The concrete is reinforced and fiber reinforced. The mosaic structure contains natural marble or granite stones. They can be combined in different colors and are of a specific size. The planks are specially treated, which protects them from rotting and preserves the material's characteristics over time. The concrete surface is embossed and further treated with a protective coating. This makes the product even more resistant to aggressive weather conditions. The elements connecting the main components are from stainless steel. Together with its classic composition, the comfort in the seating area is achieved through its specially intended ergonomic design. The emphasis of the product is the vintage design solution for the concrete bearing parts. Great decoration for various urban areas, parks, alleys, schools, playgrounds and other public spaces.



1.2 Description of the main components of the product:

The concrete bench consists of: **1.** Concrete legs; **2.** Planks; **3.** Joint plates **4.** Stainless steel fasteners*; **5.** Marking logo; (*Figure 1*)

* the full description of the connecting elements is given in the product's assembly sheet

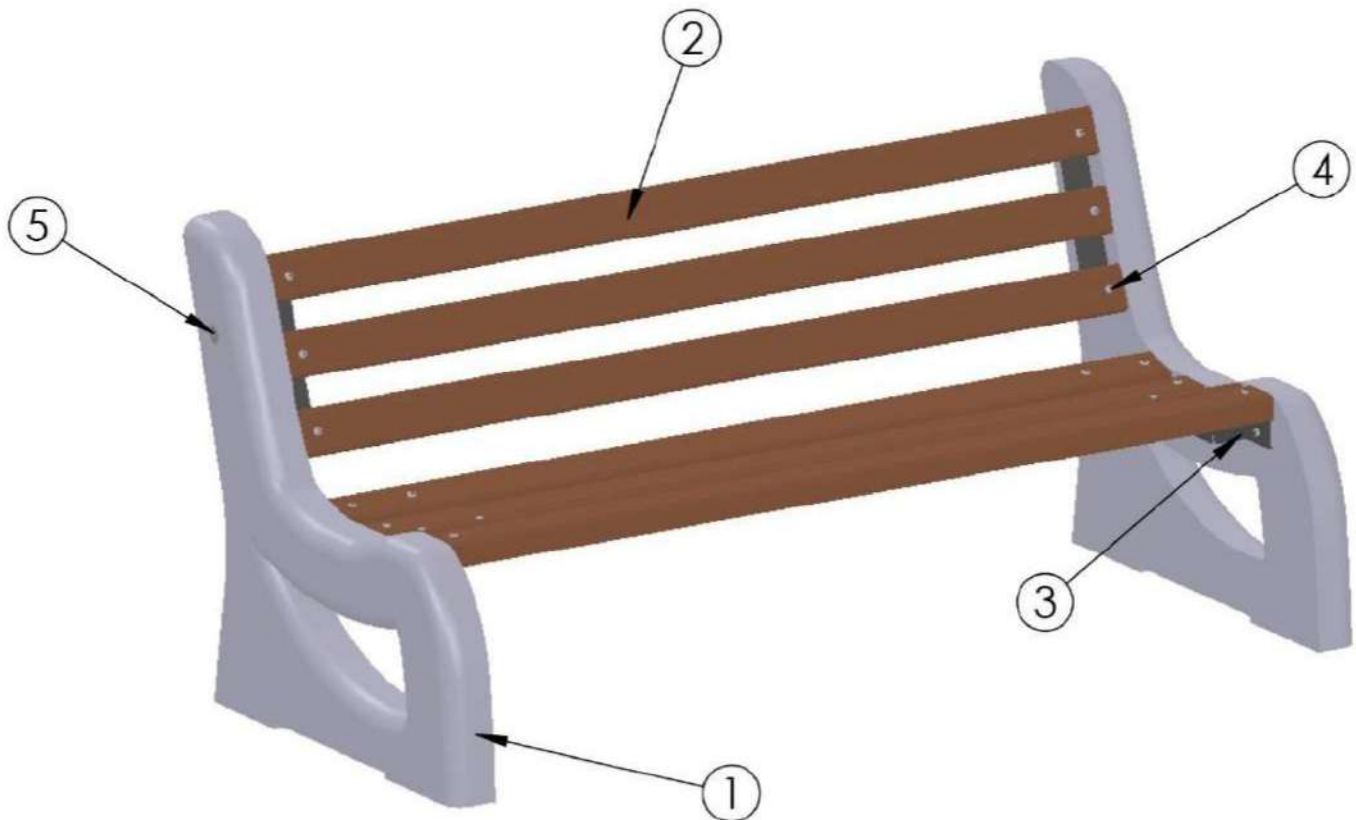

Figure 1



1.3 Description of the main materials of the product:

Concrete

High quality gray or white Portland cement is used in the production of the highperformance concrete (HPC) in combination with natural marble or granite aggregates and inert materials. The concrete structure is reinforced. Concrete is recyclable due to the absence of resins and adhesive polymeric agents.



Natural marble aggregates

The aggregates are a mixture of multi-colored, natural, marble or granite stone fractions with Portland cement and inert materials. The particles have selected structural characteristics and are available in various combinations with grey or white Portland cement, depending on their properties and requirements for the manufacture of the products. Embossed structure of the aggregate.



Wood/Timber

Wood is a natural material and every beam/plank is not identical to the others, and there may be slight differences in the appearance of the woodthread, the tone and the natural imperfections, despite the processing. As the weather changes (hot climate, dry climate, humid climate, cold climate), the wood structure changes and can increase or decrease its volume, causing cracks or fissures. Although it is a natural process, it should be noted.



Spruce is offered as solid wood with a selected part of the structure of the tree. The wood is treated with high-performance impregnators and water-based varnishes that extend the life of the wood and slow down the aging of the material. This procedure does not cancel the subsequent periodic maintenance of the timber in order to keep its quality for as long as possible.

Color range is selected and ordered upon request by the customer and is available in the following options: pine color, walnut color, mahogany color, rosewood color, oak color.



Stainless steel

Encho Enchev - ETE uses AISI 304 stainless steel.

Marking logos and all fasteners used to assemble the product are made of stainless steel.

STAINLESS STEEL

#81



AISI 304

1.4 Technical description of the product:



Table 1: Technical description

Component	Dimensions	Material	Covering
Concrete legs (2 pieces)	L: 870 mm B: 80 mm H: 810 mm	Concrete with marble or granite aggregates (terrazzo), Surface – embossed	Varnish - gloss (EN 1504-2)
Planks (7 pieces)	L: 1550 mm B: 80 mm H: 43 mm	FSC certified soft spruce wood	Pigmented waterborne top coats(impregnator and varnish) (ISO 9001)
Joint plate (2 pieces)	δ: 3 mm (with specific shape and dimensions)	Steel DC01 AM O EN 10130:2016	Ester-epoxide hybrid primer (ISO14001:2015) Electrostatic solid powdered polyester (ISO14001:2015)
Marking logos	Ø: 33 mm	Stainless steel AISI 304	-
Fasteners (all bolts and dowels)	-	Stainless steel AISI 304	-
General dimensions	L: 1710 mm B: 870 mm H: 810 mm Weight: 120 kg	-	-

1.4.1 Regulatory references applicable to products:

Table 2

EN 13198:2003; EN 13369:2019; EN 206:2021
EN 13043; EN 13139; EN 13242 EN ISO 9001:2015; EN ISO 14001:2015

1.4.2 Declared indicators of the characteristics of the concrete product:



Table 3

Characteristic	Indicator	Test/calculation/determination method
Tolerances in nominal dimensions	$\pm 2\%$, Level I	
Minimum thickness of the concrete cover	80 mm	EN 13198:2003
Concrete strength class	C60/75	EN 12390-3:2009
Environmental impact classes	XC4, XS3, XD3, XF3, XA1	EN206:2021
Watertightness	C_w 1.0	EN206:2021
Frost resistance	C_{fr} 150	EN206:2021



3. Construction and production drawings for Concrete bench Model 2

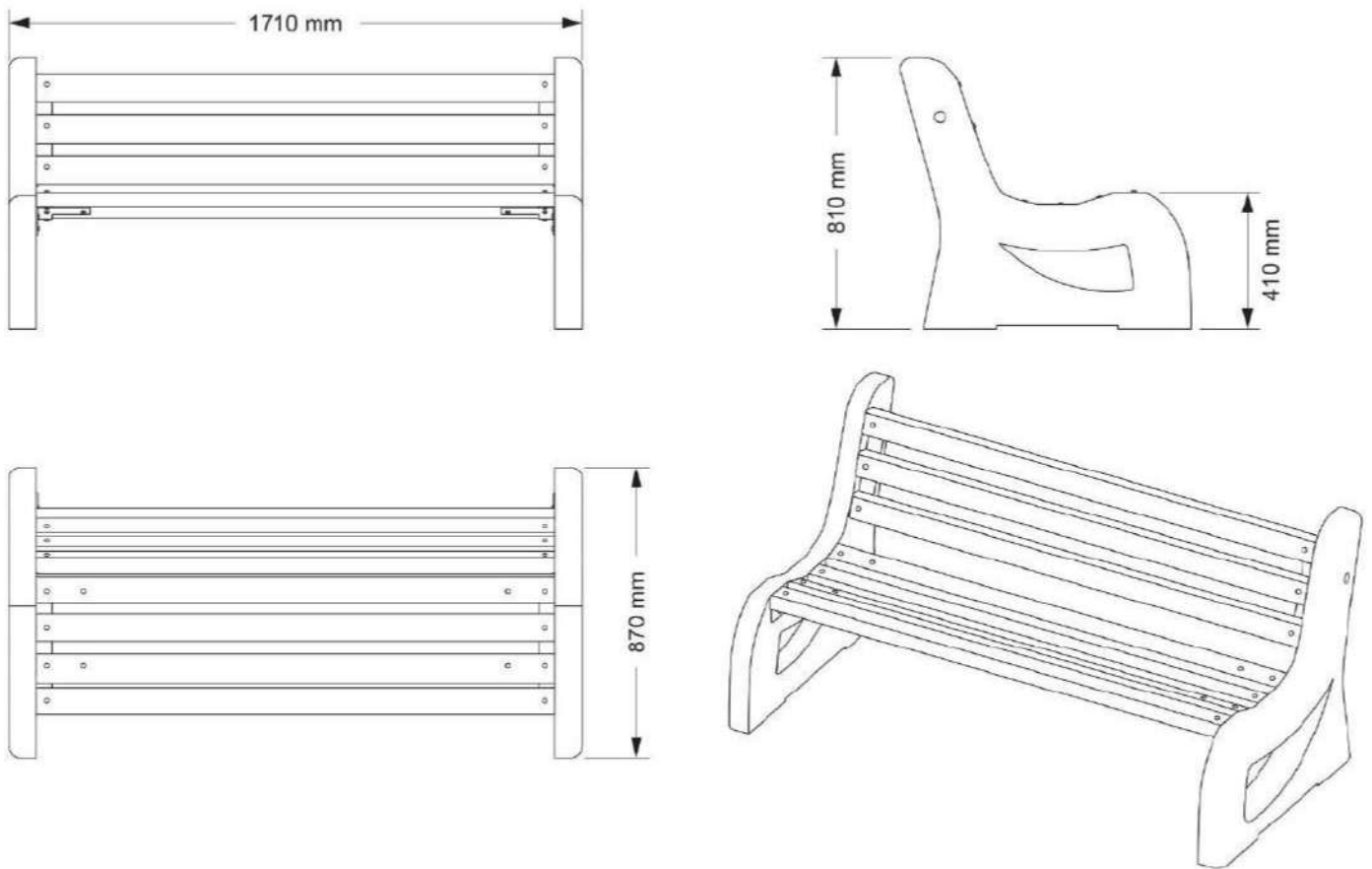

Figure 2





4. Intended use of the product

Application:

Ready-made concrete product for exterior and / or interior application in public and private areas for decorative design with practical and functional application on streets, parks, gardens, recreation areas and others. The concrete bench is designed and manufactured as an item for rest and relaxation, intended for use by a person in a sitting position. The product meets the requirements specified in standard EN 13198: 2013, EN 13369: 2019, EN 206: 2021 and is manufactured according to an assessed and certified production control system, in accordance with the requirements of EN ISO 9001: 2015 and for protection of the environment according to EN ISO 14001: 2015.

Note:

Any applications other than those specified, may result in damage to the integrity of the product as well as personal injury as a result of improper use.

The product should be serviced, cleaned and maintained by authorized persons.

Company Encho Enchev - ETE is not responsible for improper use and maintenance of the product.

Replaceable parts:

All components of the product listed in **Table 1** can be ordered from the company and replaced with new ones in case of failure.

Maintenance and support:

To keep the appearance of the product unchanged for a long period of time, we recommend that the products be cleaned. Recommendations for cleaning and maintenance can be found on the company's website.

Product recycling:

All materials used in the manufacture of this product are recyclable.



5. Additional information

This TECHNICAL DOCUMENTATION (SPECIFICATION) is issued entirely at the responsibility of the manufacturer and applies to concrete products manufactured according to an assessed and certified production control system, in accordance with the requirements of EN ISO 9001: 2015 and environmental protection requirements according to EN ISO 14001: 2015. These indicators are based on laboratory tests conducted by independent, certified laboratories.



-  25 Dimitar Blagoev str.,
Dolna Oryahovitsa, Bulgaria
-  +359 88 227 9759 / +359 88 227 7414
-  +359 6173 2272
-  sales@etebg.net
-  www.etebg.net



Product name:

Concrete litter bin model 43

Dimensions:

Ø: 38 cm H: 84 cm L: 50 cm, 60 kg

Link to the product's page:

Description:

Model of the product range of concrete bins by Encho Enchev-ETE, made out of concrete, high-quality metal and certified wood. The concrete is high-performance, reinforced with an aggregate of natural marble or granite stones. The stones are defined in size and can be combined in different colors. The surface has a characteristic relief. A special lacquer coating is applied to the wooden slats and the aggregate, which protects the wood from rotting and makes the product even more resistant to aggressive weather conditions. The metal lid has an integrated ashtray. The treatment of the metal components by galvanizing and powder coating methods creates high corrosion protection and increases performance. The concrete bin has an internal container of galvanized metal for waste collection, providing easy access for cleaning and maintenance. Possibilities for different color combinations of the aggregate, metal and wooden elements give a distinctive personality and style. An anchoring option for flooring is also available. The combination of functionality and durability, complemented by the beauty of the natural materials used, make the garbage bin an ideal complement to the design of exterior spaces in parks and gardens. Maintaining a high standard and quality, Encho Enchev - ETE meets the most sophisticated landscape architectural requirements in furnishing private properties, hotels, holiday villages and resorts. An elegant and practical solution for the equipment of bus stops, metro stations, rail stations, terminals, as well as beaches, alleys, schools, playgrounds and other public areas. Keep the environment clean and think about the future of the planet with Encho Enchev - ETE's concrete bins.

Keywords:

Encho Enchev – ETE, concrete litter bin, concrete waste bin, concrete trash can, concrete litter bin with ashtray, concrete park garbage bin, street furniture, urban furniture, park furniture, interior design, exterior design, public spaces, outdoor furniture, garden, parks, concrete bin with metal lid, individual projects, outdoor spaces,

Related products:

Concrete litter bin model 45, Concrete litter bin model 18, Concrete litter bin model 69





ENCHO ENCHEV - ETE

LITTER BIN №43

+359 88 2277414 ; +359 6173 2272
www.etebg.net sales@etebg.net

