

Automatic Control Panels & Manifold Systems for Cylinder Station Plants of Hospitals

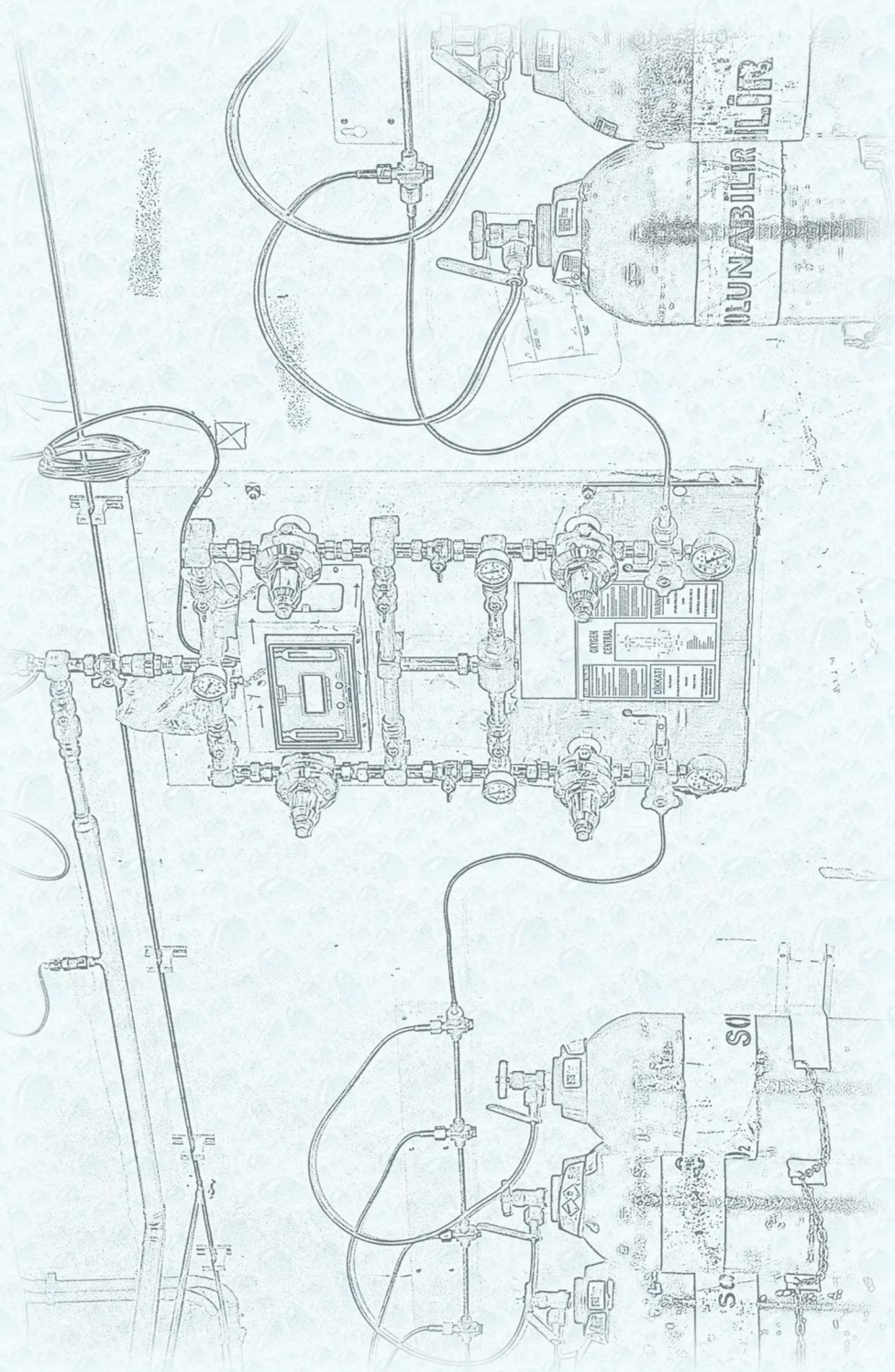



Automatic Control Panels

The automatic control panels are used in places like (hospitals, clinics, etc) with the aim to feed the net systems for distribution of medical gas: oxygen, nitrous oxide, compressed air, carbon dioxide, nitrogen. The reducers have been tested to a pressure higher than 300bar.

This device reduces the changeable pressure inside bottles. The inverter gives the possibility to change in an automatic way between 2 sources generally 2 bottles or groups of bottles. The device is linked to 2 sources of a system and changes in an automatic way thanks to the inverter between an out of work source and a working one.

Cylinders Station Automatic Control Panels, manufactured as 3 different models of 30, 90 and 150 m³/h capacities, for use in medical gas systems, are to reduce and regulate the output pressure of the supply source suitable for use with medical equipment via connections to terminal units or to be applied directly to the patient. The unit is also equipped with necessary valves, transducers and manometers for the control and monitoring of the system.

On cylinders station automatic control panels for single or double stage systems, there are electronic transducers (sensors) in order to adjust the low-high pressure set values, conveying the pressure data to the audible-visible alarm.

First class materials, in compliance with relevant standards, are used in the production of the units and the products are offered to service using advanced installation techniques.



IDENTIFICATION

- Double stage automatic change-over panel for medical gas distribution systems
- Double pressure regulation between high pressure source and distribution line
- Pressure monitoring by means of pressure transducer sensors
- Integration of alarm module in S/s cabinet
- Mounted on steel back panel laser-marked plate indicating production lot and product code
- Cover panel with plexyglass window for constant monitoring of outgoing line pressure gauge and alarm module

CE MARKING

- CE Notified body
- CE marking in risk class II B in accordance with Legislative Decree 24 February 1997, no. 46 "Implementation of Directive 93/42/EEC, concerning Medical Devices" and further modifications

REFERENCE STANDARDS

- **ISO 10524-2**: "Pressure regulators for use with medical gases -Part 2: Manifold and line pressure regulators"
 - **ISO 7396-1**: "Medical gas pipeline systems - Part 1: Pipeline systems for compressed medical gases and vacuum"
 - **HTM 02-01**: "Medical gas pipeline systems"
 - **ISO 15001**: "Anaesthetic and respiratory equipment. Compatibility with oxygen"
- * Validity of the standards is referred to the current year



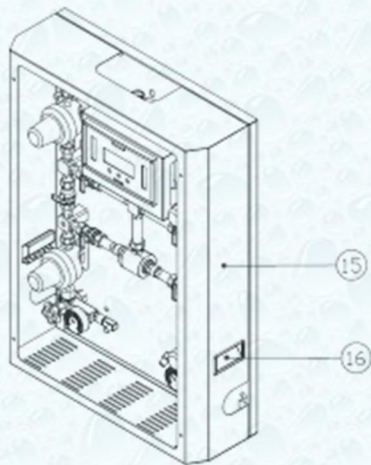
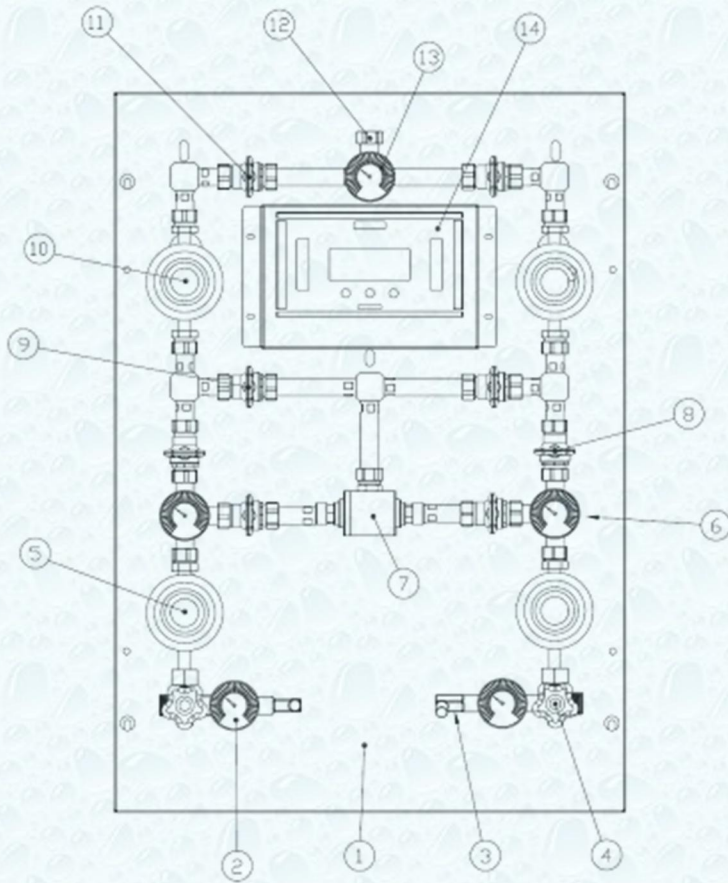

Equipment List:

- 1—Stainless Steel Back Panel
- 2—HP Pressure Gauge
- 3—Transducer Sensor for High Pressure
- 4—HP Inlet Valve
- 5—1st Stage Pressure Regulator
- 6—Intermediate Pressure Gauge
- 7—Automatic Pneumatic Change-Over
- 8—Maintenance Valve (Normally Closed)
- 9—Maintenance Valve (One side Open / Other side Closed)
- 10—2nd Stage Pressure Regulator
- 11— Maintenance Valve (One side Open / Other side Closed)
- 12—Output Connection (Line to Hospital Feeding)
- 13—Line Pressure Gauge and Transducer Sensor for Line Pressure (at the back side of Line pressure Gauge)
- 14—Digital Alarm Module
- 15—Outer Metal Cover with Front PlexGlass
- 16—Handle for Cover

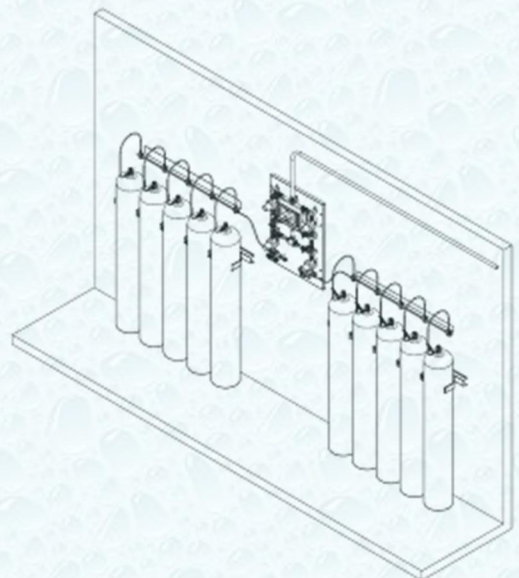
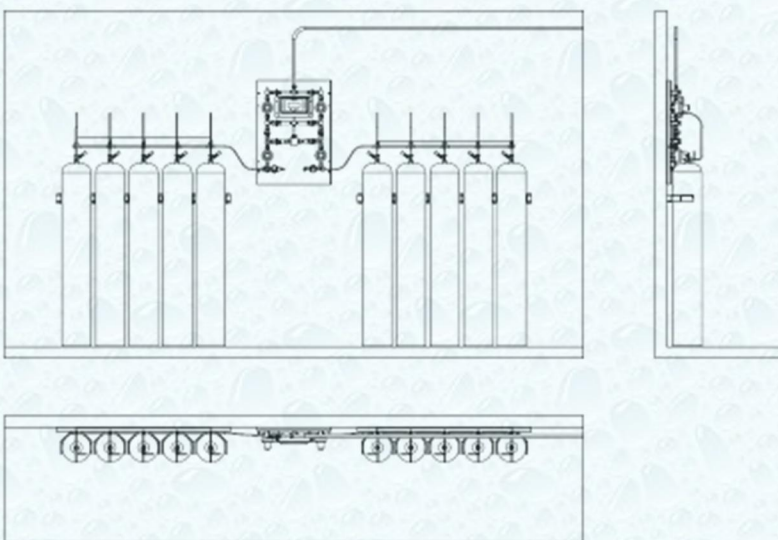

Automatic Control Panel Technical Data 25/90/150 m3/h

Inlet Pressure (P1)	220 Bar (300 max.)								
Reducer Set Pressure (Pi)	10 Bar								
Reducer Set Pressure (P2)	4,5 Bar								
Flow Rate with 200 Bar in	30 m3/h	Pi (Bar)	P2 (Bar)	90 m3/h	Pi (Bar)	P2 (Bar)	150 m3/h	Pi (Bar)	P2 (Bar)
Environment Conditions Temperature: 23 °C Pressure: 101,3 kPa	9	10,4	4,6	20	10,6	4,6	55	10,4	4,6
	12	10,1	4,6	35	10,4	4,6	96	10,3	4,5
	24	9,8	4,5	75	10	4,5	143	9,7	4,5
	33	8,6	4,1	100	8,9	4,2	162	8,8	4,2
Max Internal Leakage	<0,2 ml/min		Inlet Connection				3/4" male		
Automatic Change Pressure ΔP	2 Bar		Outlet Connection				22x1mm Copper Pipe		
Low & Line Pressure Gauge	0 - 16 Bar		Inlet Pressure Gauges Scale				0 +300 bar		
High Pressure Gauge	0 - 300 Bar		Inlet Pressure Gauges Scale for CO2 & N2O				0 +160 bar		
Working Temperature	-20°C ~ -+70°C		Intermediate Pressure Gauges Scale				0 + 16 bar		
Test Gas	N2		Outlet Pressure Gauges Scale				0 + 10 bar		
Test Pressure	300 Bar		Pressure Gauges Precision Class				2.5		
Factory Adjusted Output Pressure	4.5 ~ 5 Bar		1st and 2nd Stage Regulators Inlet Degree of Filtration				24 μm		

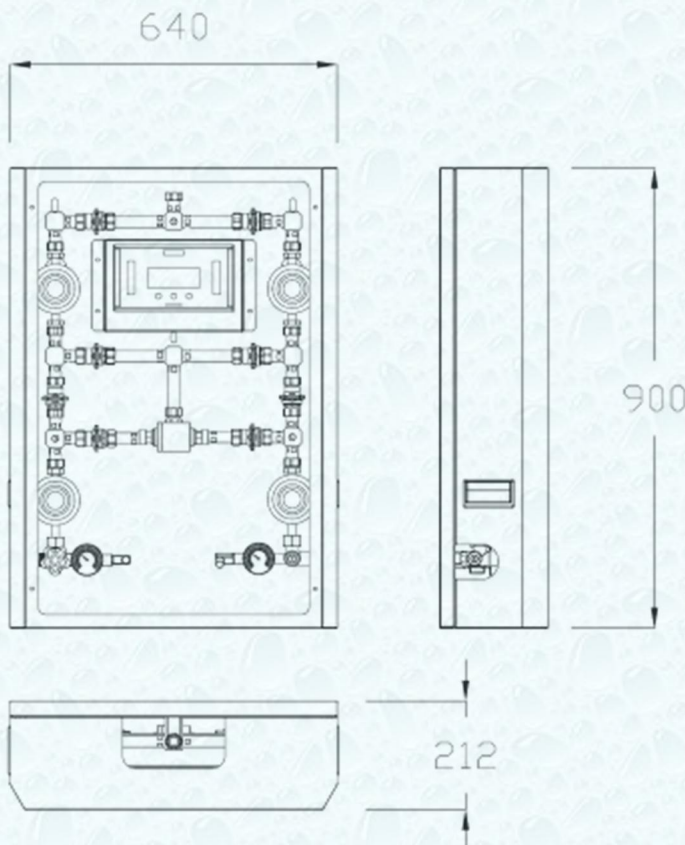

Dimensions & Weights

Packing Type : Carton Box

Packing Sizes : 70 x 40 x 100 cm

Wrapped Bubble Nylon and
Stretcher Excluded

Weights:

25 Kg for Capacity of 25 m3/h

48 Kg for Capacity of 90 m3/h

66 Kg for Capacity of 150 m3/h

All External equipment and Con-
nection Excluded



Automatic Control Panel of 30 m3/h Capacity



Manual Control Panel of 30 m3/h with 2nd Stage Regulator



Manual Control Panel without Alarm

MANIFOLDS

Manifolds have the role to carry the gas from the bottles to the automatic control panel, or to the emergency control panel. The manifold is made up of a copper pipe and of a non-return device. The non-return device (made of brass CW614N) are connected to the copper pipe, thanks to a silver soldering without cadmium.

Manifolds allow to connect in parallel more cylinders, or cylinders bundles of the same gas upstream the first stage reducer. Each cylinder seat is equipped with a non-return device that assures to work in total safety. Manifolds are available in 1 to 5 cylinders seats. If it is necessary to connect more than 5 cylinders (or cylinder bundles) it will be possible to install more manifolds connecting them to each other with gas specific pigtailed. The connection between cylinder and manifold and between main panel board and manifold must be realized by means of connecting devices (pigtailed) specific for the treated gas according with norms ISO EN 21969 and ISO EN 7396. At the ends of the manifold, there are two male thread used to connect the flexibles at one end and to discharge gases in case of danger.

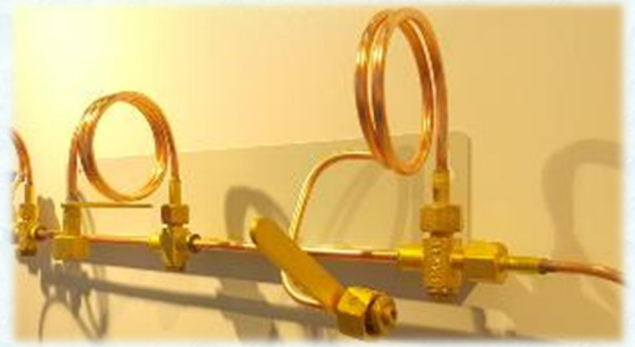

- Flexible pigtail pipe for connection between cylinder manifolds, Control Panel and HP scavenging valves
- Gas-specific threaded inlet fitting in compliance with national standards
- Laser-marking of gas, production lot and product code
- The input threads meet the ISO requirements and depend on the gas.

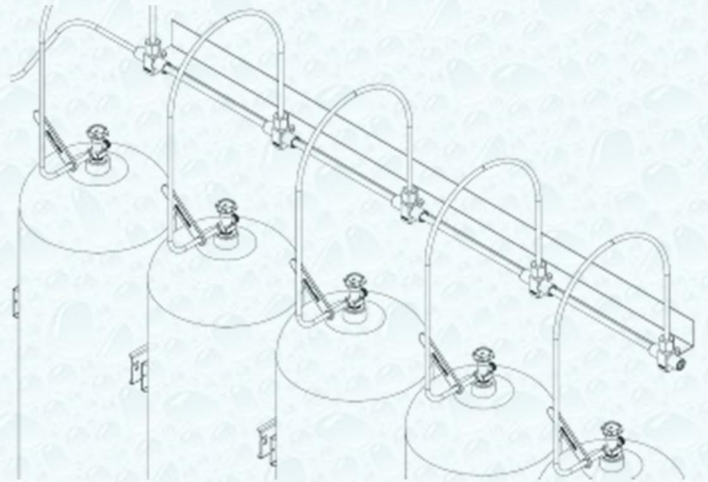

CYLINDER RACKS

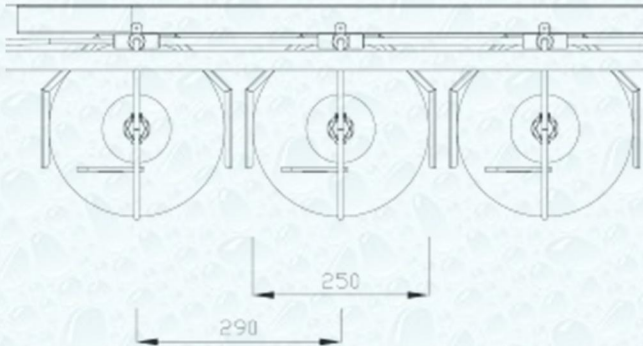

- Wall rack for holding gas cylinders - Customization of number of cylinder seats (on request)
- Chains for fastening cylinders in vertical position - C section profile with holes for secure wall fixing

HP MANUAL SCAVENGING VALVE



High pressure relief valve (one for each manifold or bank of manifolds). Shut-off valve with spindle seal. Degreased for use with oxygen in compliance with ISO 15001

Working pressure: P= 200 bar

Available with fitting for pipe welding on inlet and outlet sides

MANIFOLD SYSTEM DESIGNS

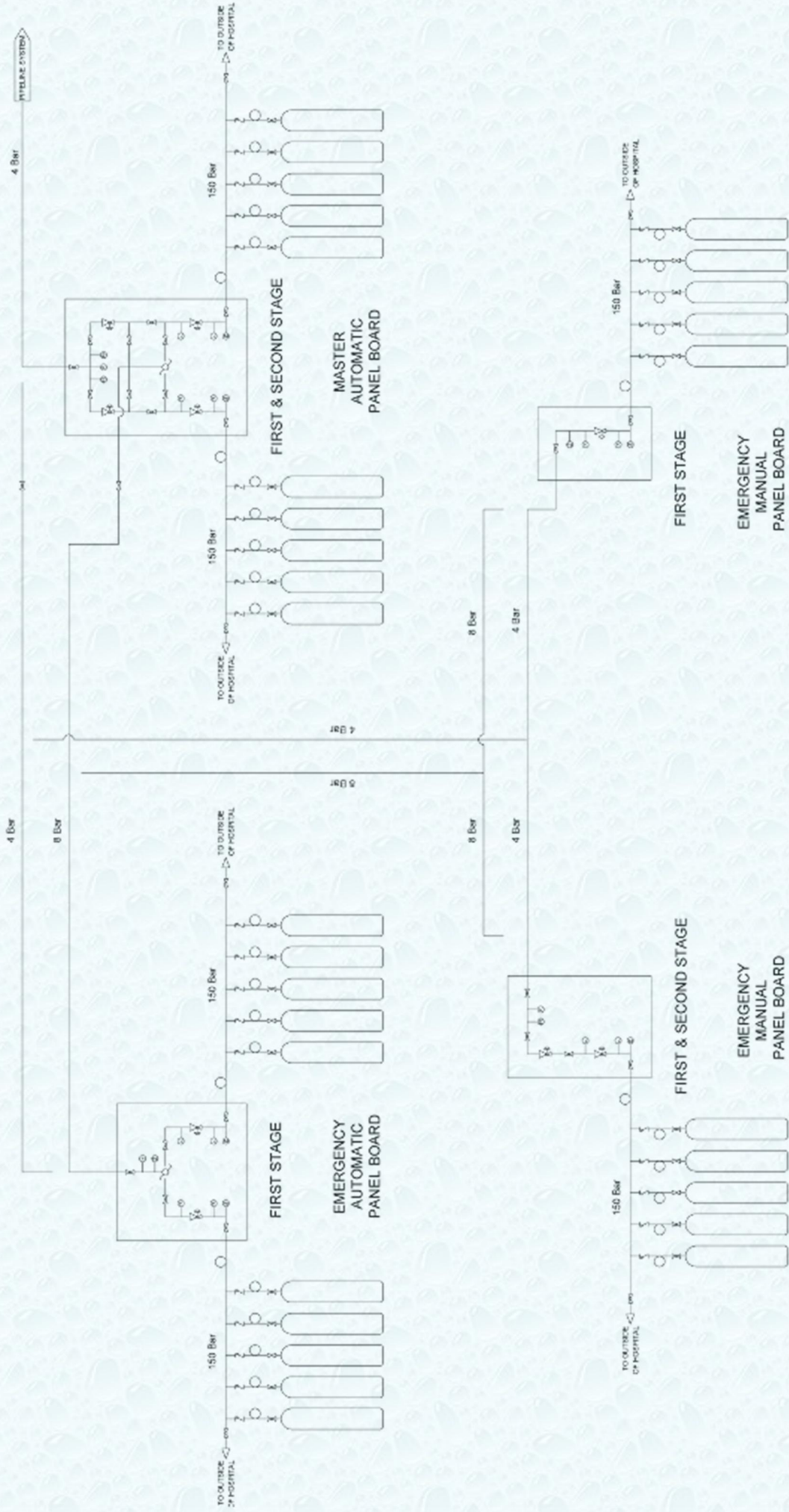



Automatic Control Panel with Selenoid Controller



With Box & Plexyglass Cover



Digital Alarm for Left/Right Banks and Output Line

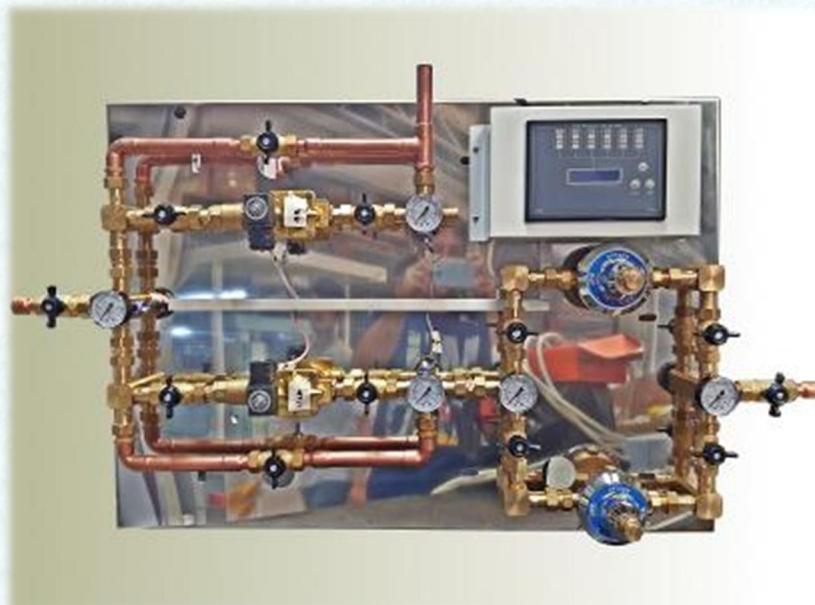

Selector Panel between Primary Supply (as Liquid Tank) and O2 Manifold System



Automatic Panel Board



Single Stage Automatic Control Panels



CONTROL PANELS

Model Number	Description
RLT X / P Y	Double Stage Automatic Control Panel
RLT X / P Y - (S)	Single Stage Automatic Control Panel
RLT X / P Y - (M)	Double Stage Manual Control Panel
RLT X / P Y - (MS)	Single Stage Manual Control Panel

X : Specify the Gas Type

O2	Oxygen
NO	Nitrous Oxide
CO	Carbondioxide
BH	Dry Air
N2	Nitrogen

Y : Specify the Capacity of Control Panel

30	30 m3/h
90	90 m3/h
150	150 m3/h

MANIFOLD PACKAGE Complete with Ramp, Flexible Connections, HP Scavenging Valves etc..

Model Number	Description
RLT A / P BC	Manifold Package

A : Specify the Gas Type

O2	Oxygen
NO	Nitrous Oxide
CO	Carbondioxide
BH	Dry Air
N2	Nitrogen

BC : Description of Manifold Package

B	Total Number of Manifold Ramp (Group)
C	Number of Flexible Connections of Each Ramp

EXAMPLES:

RLTO2/P90 : DOUBLE STAGE AUTOMATIC CONTROL PANEL (90 m3/h Capacity)

RLTCO/P30—(MS) : SINGLE STAGE MANUAL CONTROL PANEL (30 m3/h Capacity)

RLTO2/M84 : MANIFOL PACKAGE FOR OXYGEN WITH ALL EQUIPMENT FOR 16 CYLINDERS LEFT & 16 CYLINDERS RIGHT

RLTNO/M25 : MANIFOL PACKAGE FOR NITROUSOXIDE WITH ALL EQUIPMENT FOR 5 CYLINDERS LEFT & 5 CYLINDERS RIGHT

MEDICAL GAS SUPPLY ALARM

GENERAL FEATURES

Medical Gas Supply Alarm is a medical gas alarm. Medical Gas Supply Alarm device area of use: Hospitals and medical gas plants of medical buildings. Intended use: Monitoring the gas tanks and emergency tubes as to whether they are filled or not, generating an alarm when they are empty or generating an alarm when the output pressure is outside the limits.

Which device to use for the gas station can be determined from the device. Alarm detects whether the tank is full or empty by using the info obtained from left bank tubes, right bank tubes, emergency tube, pressure contacts or pressure sensors connected to liquid oxygen or liquid nitrogen tank.

If pressure switches are used instead of pressure sensors in the tanks, tank empty alarm is generated when the contact is opened or closed. The fill status of the following tanks is monitored:

Line pressure
Left bank
Right bank
Liquid tank

- 4x20 characters blue back light screen
- Tracking of up to 4 gas lines
- Ability to observe moisture and temperature information in the air
- The unused resource name can be canceled from the menu.
- Data transfer via RS485 – MODBUS RTU
- Can be mounted to walls and boards
- Easy-to-use menu screen

- Microprocessor-controlled electronic system,
- Ideal for scientific applications with Bar, PSI, mmHg, cmHg, ATM, pa, Kpa, Mpa options
- Led display for remote monitoring of the empty and full tubing for right and left ramp
- Multi-language options,
- Dry contact for alarm, audible and visual warning outputs
- Measuring moisture and temperature levels in the pipe (optional)
- Ethernet output (optional)





MED BIRLESIM

MEDİKAL SANAYİ TIC. LTD. STİ.

Perpa Is Merkezi B blok Kat: 5 No:130 Okmeydanı İstanbul

Tel:+90 532 6569779 / 0 532 7719214

www.medbirlesim.com info@medbirlesim.com

