

5 PRODUCT REALIZATION

- **MANUFACTURING DESCRIPTION**

BD SurePath™ Collection Vial Kit 500 is assembled at the Mebane, North Carolina facility. Major manufacturing processes are described in the Figures 1-3 below.

Product is shipped from the Mebane facility to BD distribution facilities, distributors and customers around the world.

The manufacturing, quality assurance (QA) and packaging specifications for each of the BD SurePath™ Collection Vial Kit 500 are contained within controlled documents. The Device History Records (DHRs) referenced below for finished products, include a Bill of Materials (BOM), manufacturing instructions, QA inspection and testing and packaging instructions required to assemble and release products for sale. The DHRs may reference other procedures for detailed work instructions and additional specifications. Purchased kit components have QA specifications provided to suppliers and are subject to incoming inspection.

SAP REF Number	Trade Name	Device History Record
491452	BD SurePath™ Collection Vial Kit 500	491452 – DHR: BD SurePath™ Collection Vial Kit 500

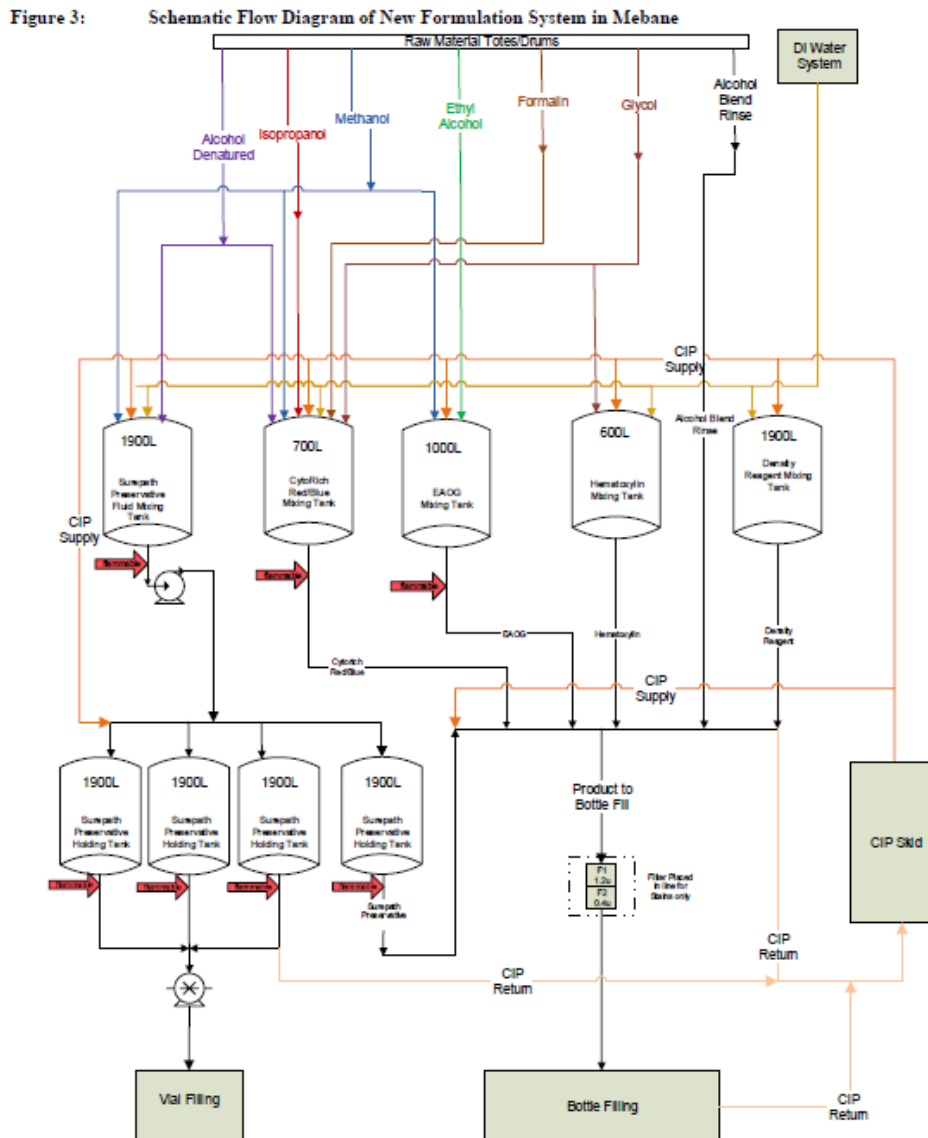

Figure 1: Bulking Manufacturing Process

The formulation system is a closed system with all product contact surfaces constructed of non-reactive 316L stainless steel. Product flow paths are constructed of chemically inert polytetrafluoroethylene (PTFE) and ethylene propylene diene monomer (EPDM) rubber. BD SurePath™ Preservative Fluid, BD Density Reagent, and other BD general purpose reagents will be manufactured using this system, which is located in the Mebane bulk reagent production area. The new formulation system was designed with five (5) 316L stainless steel tanks. Two 1900L tanks are dedicated to production of BD SurePath™ Preservative Fluid and BD Density Reagent. The remaining tanks are used for manufacture of other BD general purpose reagents. Upon completion of a formulation batch, product will be transferred directly to either a hold tank (BD SurePath™ Preservative Fluid) or directly to the bottle filling line. An automated Clean in Place (CIP) skid will be utilized to clean all product contact surfaces prior to subsequent operation.

Figure 8: New Vial Filling Line (Shibuya) Process in Mebane

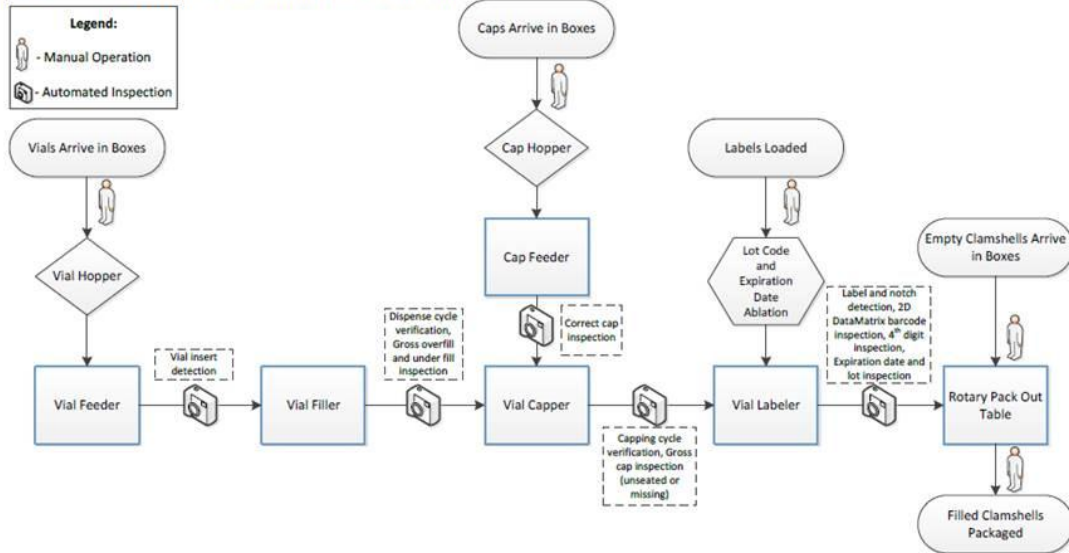

Figure 2: Vial Manufacturing Process

The vial filling line (Shibuya) provides an automated and integrated means of filling, capping, and labeling of Vials. Vials and caps are oriented and fed to a filler/capper mono-block enclosure through guarded pre-feeders.

The vials are filled from eight filling nozzles, with continuous feedback confirmation of fill volume. The caps are applied to filled vials using an eight head rotary servo capper, with 100% confirmation of applied torque. Any vial with inadequate fill volume or cap torque not meeting specification is automatically rejected. Filled and capped vials are oriented and presented to a turret labeler for labeling. Upon depletion of a label roll, a second label head automatically engages. Following application of the vial label, lot number and expiration date are printed on the burn box via CO2 laser. The legibility of the lot number, expiration date code, and label barcode are verified using vision equipment. Discrepant parts are rejected from the line. Conforming filled, capped, and labeled vials progress to a rotary table for manual pack-out into kits.

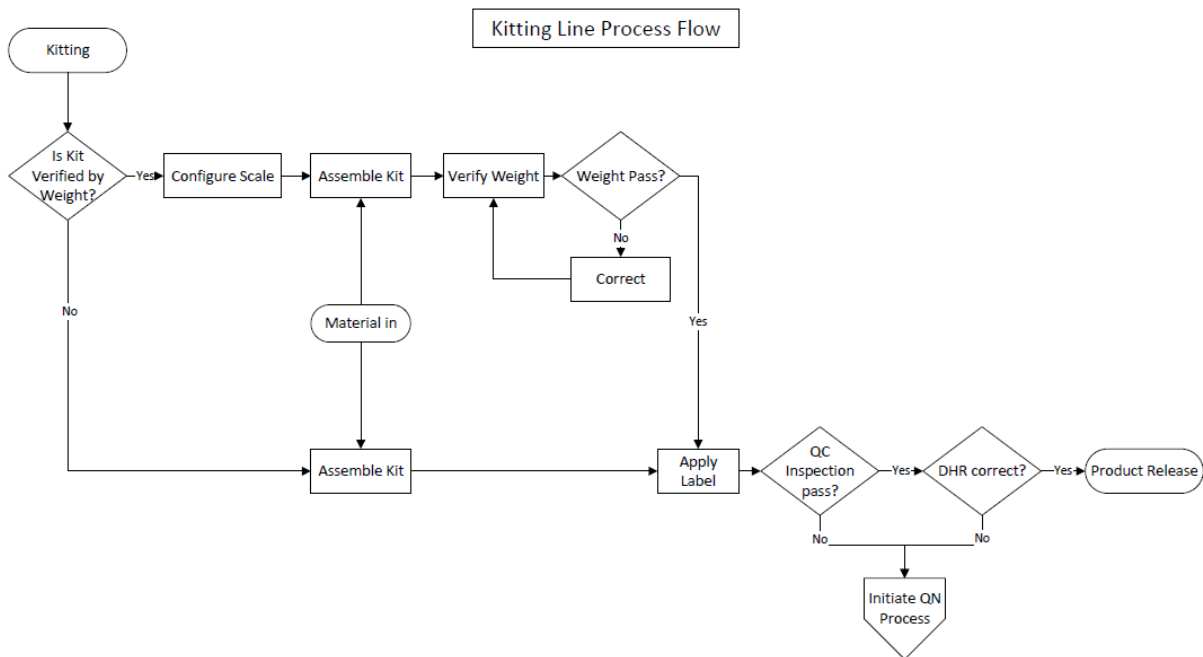

Figure 3: Kitting Manufacturing Process

Semi-finished and finished goods will be manually assembled, packaged, and labeled in the Reagent Kitting area according to the applicable Bill of Materials. Lot-specific information will be printed on the product label and will be manually verified during quality inspection.

- **QUALITY CONTROL**

Batch release testing is described in the DHR for each product listed in Section 5 "MANUFACTURING DESCRIPTION" of this Technical File.

- **ENVIRONMENTAL CONTROLS**

Temperature requirements are maintained in areas where materials and products are processed and stored to be between 15 °C and 30 °C.

The humidity requirements for some areas are 20% to 80% RH depending on the area. In the high hazard areas where flammables are processed humidity is maintained above 20% RH. In some areas there are equipment operation requirements of 30% to 70% RH.

- **ENVIRONMENTAL COMPLIANCE**

Not Applicable; the product (BD SurePath™ Collection Vial Kit 500) described in this Technical File is a reagent and is not an electrical device.