



Data Sheet

JetFlex[®] Disc Diffuser - HD 270

F053 J27



Installation drawing

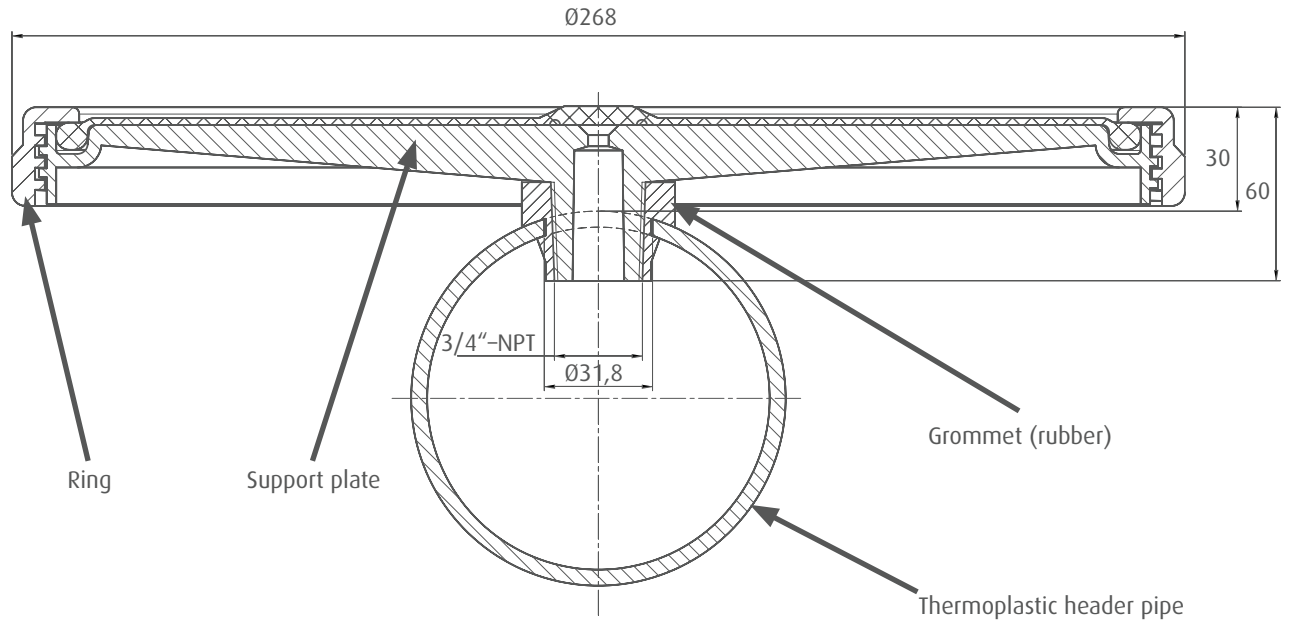

Dimensions

| Hight | Diameter total/effective | Overall height membrane top of tube | Perforated area | Orifice | Thread | Check valve |
|-------|--------------------------|-------------------------------------|-------------------|---------|--------|-------------|
| [mm] | [mm] | [mm] | [m ²] | [mm] | | |
| 60 | 268/218 | 30 | 0,037 | 8 | R 3/4" | On request. |

Air flow

| Air flow rates at standard operation conditions | max overload/maintenance air flow rate | Operating temperature | Operation mode | Application |
|---|--|-----------------------|----------------------------|--------------------------|
| [m _N ³ /h] | [m _N ³ /h] | [°C] | | |
| 2-6 | 10 | 0 – 80 | intermittent continuous | municipal waste water |

- Shutdown of operation is highly recommended for air flow rates lower than minimum rate.
- Overload air flow rate (e.g. cleaning) should not be applied longer than 10 min/day.
- Numbers are for guidance only. Operating diffusers at too high or too low an airflow rate may reduce lifetime or performance. See Technical Report 'Slit size for aeration membranes' for details.



Connectors to header pipe

| Type | Permitted wall thickness of header tube | Diameter of straight-drilled hole | Material | Colour |
|--|---|-----------------------------------|----------------------------|-------------------------------------|
| | [mm] | [mm] | | |
| Universal Saddle PVC-Saddle 90 mm PVC-Saddle 110 mm | 2 – 8 | 31,8 (1 1/4") 35 35 | EPDM 75 Sh A PVC PVC | Black White/Black White/Black |

Membrane material

| | | |
|--|--|---|
| Type Colour | | F053 EPDM Black |
| Polymer Carbon black Plasticiser Others | | 33 % 31 % 33 % 3 % |
| Density Tensile strength Elongation at break Tear strength Hardness Tension set | DIN EN ISO 1183-1:2004 DIN 53504 DIN 53504 DIN ISO 34-1:2004 DIN 53505; ASTM D 624 B DIN ISO 2285:2003-0753505 100 % Elongation; 24 h, RT | 1,08 ± 0,03 g/cm ³ > 10 N/mm ² > 400% > 7 N/mm 53 ± 5 Shore A < 5% |
| Ozone resistance | DIN 53509 | zero cracks |

Support plate material

| Material | Colour | Additional colours | Logo |
|----------|--------|--------------------|-------------|
| PP GF 30 | Black | On request. | On request. |

Shipping unit

| Shipping unit | Dimensions L x W x H | Unit weight | Unit per pallet | Pallet size | Pallet weight |
|-----------------------|----------------------|-------------|-----------------|--------------------------|---------------|
| | [mm] | [kg] | | [mm] | [kg] |
| 50 pcs./ cardboard | 800 x 600 x 360 | approx 35 | 1, 2, 3 | max 800 x 600 x 1200 | max 117 |
| 50 pcs./ cardboard | 800 x 600 x 360 | approx 35 | 2, 4, 6, 8 | max 1200 x 800 x 1550 | max 287 |

Specifications

Standard oxygen transfer efficiency (SOTE) and headloss for HD 270 F053 J27

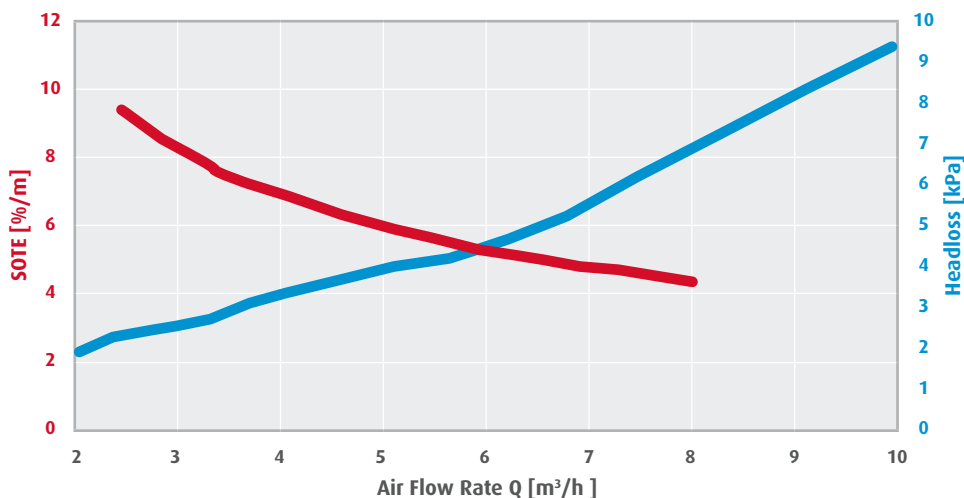

| | |
|----------------------|-----------|
| Water depth | 4,50 m |
| Submergence depth | 4,20 m |
| Atmospheric pressure | 1.013 hPa |
| Water temperature | 16,3 °C |

| | |
|-------------------|---------------------|
| Test media | tap water |
| Test tank | bubble column |
| Tank volume | 5,09 m ³ |
| Tank floor area | 1,13 m ² |
| C _{SS,T} | 9,81 mg/l |

Test conditions SOTE acc. to German Standard DWA M 209 (desorption method) Certificate ISAH, University Hanover, measuring tolerance +/- 1% Headloss internal tests tolerances +/- 5%

Storage:

- Diffuser and/or rubber sleeves must be stored factory-packed in a dark, dry, ventilated and dust-free storage space according to DIN 7716. Avoid frost, heat, UV/radiation, dust and working which can cause damage of diffuser and/or packing.
- Do not store outdoors! The storage of rubber parts until installation/starting operation should not exceed one year. At on-site delivery, all rubber and plastic parts must be stored in their original packaging. Crates exposed to direct sunlight must be covered with tarpaulin to protect against UV-radiation.

Maintenance:

Diffusers can only be checked, if the activated sludge tank is out of work and empty. That is why normal cleaning must be done at work. Formic acid is used very successfully against carbonating. To keep the pores open, formic acid is sprayed into the compressed air for a short time. Also a regular use with maximum air flow for a short time helps keep the diffuser in good conditions for a long time. (refer to Maintenance Manual)

Membrane lifetime:

Lifetime is depending on waste water influent, plant design, operation conditions and preventive maintenance measures. Reference plants have achieved more than 5 year in municipal waste water. Please refer to our standard warranty terms and conditions which can be downloaded from our website.

Disclaimer: This information is based on our present state of knowledge and is intended to provide general notes on our products and their uses. It should not therefore be construed as guaranteeing specific properties of the products described or their suitability for a particular application. Any existing industrial property rights must be observed. The quality of our products is guaranteed under our General Condition of Sale.

Jäger Umwelt-Technik GmbH & Co. KG

Rothwiese 4
30559 Hannover, Germany
Phone: (+49)511 898668-0
Fax: (+49)511 898668-99
www.jaeger-envirotech.com
info@jaeger-envirotech.com

Jaeger Rubber and Plastics (Shenzhen) Ltd.

1/F, No. A13 Factory Building
Silicon Valley – Automobile Industry Park
Guanlan, Baoan, Shenzhen,
China 518110
Phone: +86 755 29832412
Fax: +86 755 29832413
www.jaeger-shenzhen.cn
info@jaeger-shenzhen.cn

