

OCULUS

SL-IC4 (D)
SL-IC5 (D)

Slit lamp

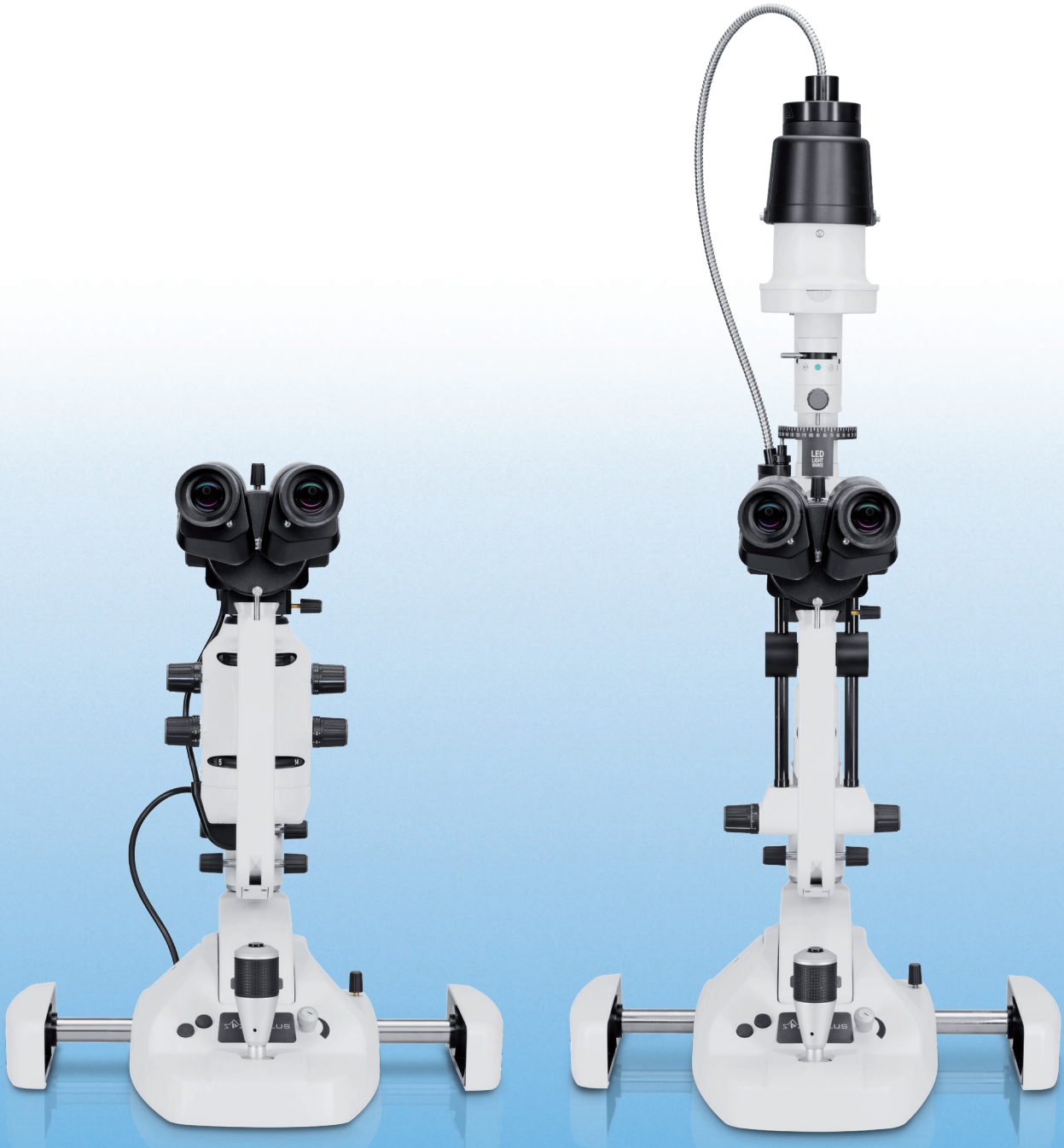

“Digital ready” – easy to upgrade to a photo slit lamp!

Both slit lamp models are available in a “digital ready” version. The OCULUS SL-IC4 D and SL-IC5 D both come with a digital port for connection to the OCULUS image documentation system ImageCam® 3. Images and videos can be conveniently captured by joystick rather than with the foot switch.



Easy capture by joystick

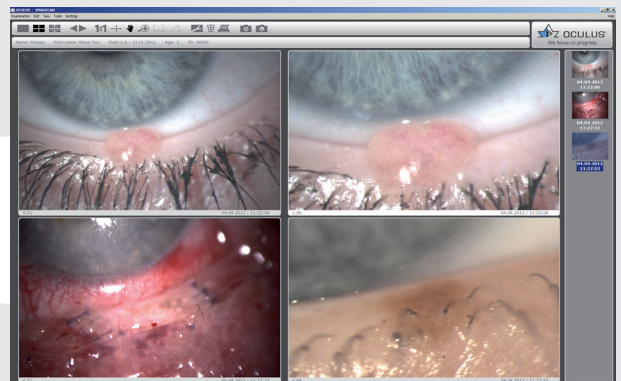

A strong partner to match – the OCULUS ImageCam® 3

Integrated background illumination for a better overview

The background illumination ensures homogenous lighting of images. It provides a fuller overall impression and facilitates the examiner's orientation. What's more, it makes the images more vivid and sharper. The background illumination system is integrated in slit lamps SL-IC5, SL-IC5 D and SL-IC4 D.



Background illumination system of the SL-IC4 D

OCULUS SL-IC4 and SL-IC5

Universal slit lamp with pioneering features

Sharp optics combined with bright, homogeneous slit illumination guarantees you a clear view with the OCULUS SL-IC4 and SL-IC5. Take advantage of the wide range of filters (blue, red free, neutral density, diffuser) integrated in the new OCULUS slit lamp to improve the quality of your examination results. Its no-hassle controls allow you to focus entirely on the examination.

Advanced optics with a magnification range from 6x to 40x

Stereomicroscope with converging binoculars and smooth-switching five-step magnification changer from 6x through 40x (6x, 10x, 16x, 25x, 40x). Integrated in the microscope is also a yellow filter which can simply be interposed when needed.

LED illumination

Bright, homogeneous and economically efficient. These carefully selected LED modules guarantee you the very best lighting conditions as well as durability.



Both models have a decoupling function as a standard feature

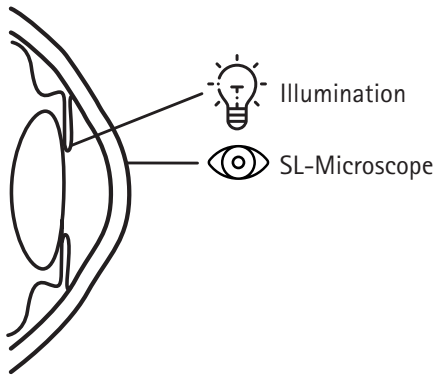

Available in two models

OCULUS SL-IC4 (D)
with a compact design

OCULUS SL-IC5 (D)
with a slim, tall design

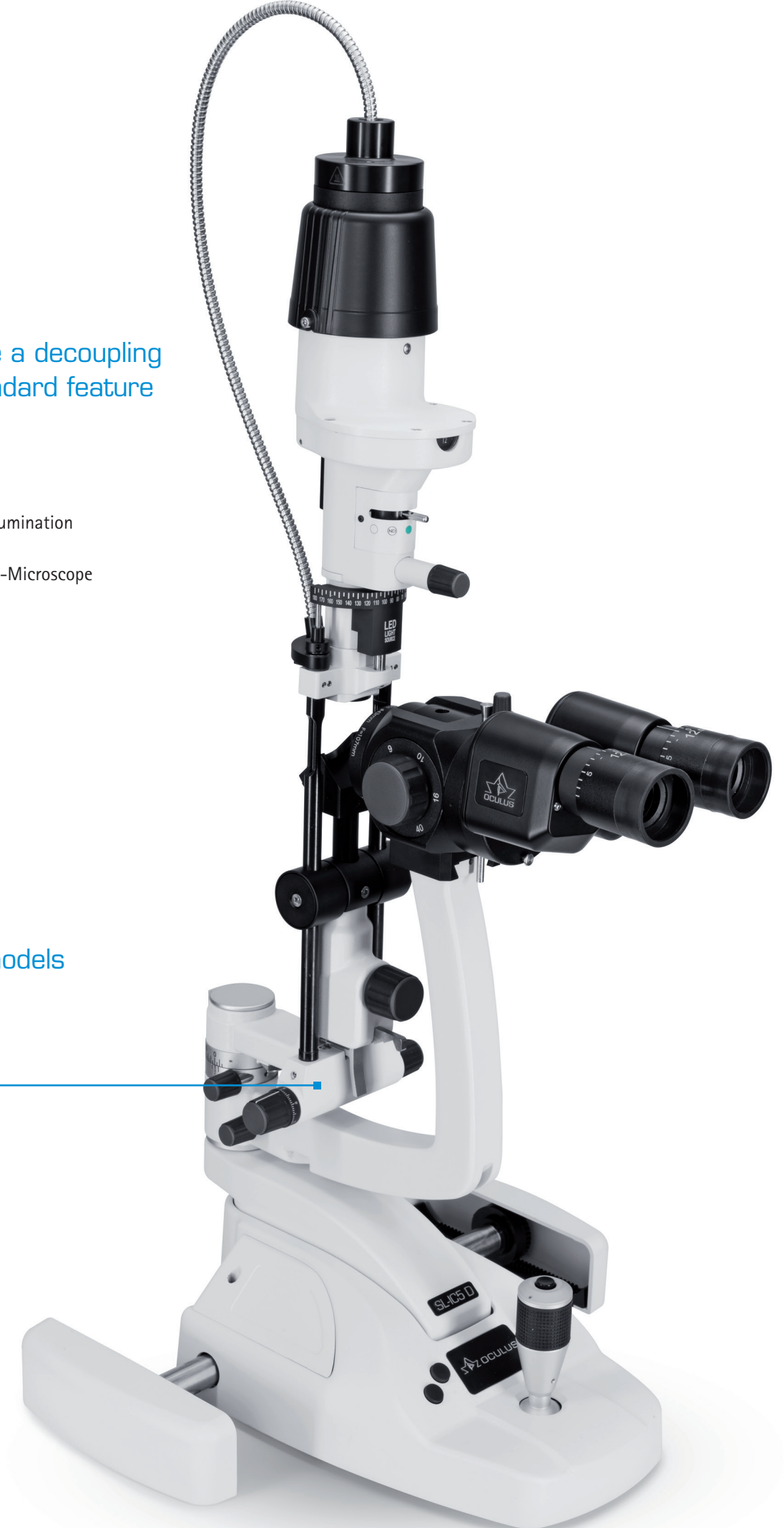

Optional accessories

For an even better performance



Eyepieces with length and angle scales for measuring the cornea and contact lens.

The **elbow support** helps steady one's hand when holding a contact lens.

Diagnostic contact lenses for inspecting the anterior chamber angle and the posterior eye segment.



Applanation tonometers

Various matching applanation tonometers for numerous popular slit lamps of most manufacturers.

Equipment table

With either model, if the OCULUS slit lamp is not to be mounted on an existing examination unit or there is no space for the OCULUS equipment table, it can be delivered mounted on a small instrument table complete with head and chin rests vertically adjustable on a lifting column.



Technical Data

SL-IC4 (D) and SL-IC5 (D)

Microscope	SL-IC4/SL-IC4 D	SL-IC5/SL-IC5 D
Type	Converging binoculars	
Eyepiece	12.5x	
Magnification	5 steps drum rotation: 6x; 10x; 16x; 25x; 40x	
Field of view	34 mm; 22 mm; 14 mm; 8.5 mm; 5.5 mm	
Interpupillary distance	49 – 77 mm	
Objective lens convergence angle	13°	
Compensation of ametropia	± 8 D	
Filter	Yellow (interposable)	
Slit illumination		
Slit projection scale	1.16x	1.16x
Slit width	0 – 14 mm (continuously variable)	0 – 12 mm (continuously variable)
Slit length	14 mm	12 mm
Aperture diameters	0.2 mm; 1 mm square; 2 mm; 3 mm; 5 mm; 9 mm; 14 mm	0.2 mm; 1 mm square; 2 mm; 3 mm; 5 mm; 9 mm; 12 mm
Filter	blue, red free, neutral density, diffuser	blue, red free, neutral density, heat absorbing, diffuser
Slit angle	360° (continuous)	0 – 180° (continuous)
Light source	LED	LED
LED colour temperature	4 000 k	4 000 k
Max. power consumption	2 W	2 W
Instrument base		
Base travel	X-axis: 107 mm Y-axis: 110 mm Z-axis: 25 mm	
Technical specifications		
Dimensions (W x D x H)	350 x 310 x 480 mm (13.8 x 12.2 x 18.9 in)	350 x 310 x 710 mm (13.8 x 12.2 x 28.0 in)
Weight	9.2 kg (20.3 lbs)	10.6 kg (23.4 lbs)
Input voltage slit lamp	12 V/24 V DC 12 – 16 V AC	12 V/24 V DC 12 – 16 V AC
Input voltage (power unit)	110 – 240 V AC	110 – 240 V AC
Output voltage (power unit)	12 V DC	12 V DC
Frequency (power unit)	50 – 60 Hz	50 – 60 Hz

CE in accordance with Medical Device Directive 93/42/EEC

WWW.OCULUS.DE



OCULUS is certified by TÜV according to
DIN EN ISO 13485 MDSAP

OCULUS Optikgeräte GmbH

Postfach • 35549 Wetzlar • GERMANY
Tel. +49 641 2005-0 • Fax +49 641 2005-295
Email: export@oculus.de • www.oculus.de

- OCULUS Asia, info@oculus.hk
- OCULUS Brasil, info@oculusbrasil.com.br
- OCULUS Canada, sales@oculus.ca
- OCULUS Czechia, oculus@oculus.cz
- OCULUS Iberia, info@oculus.es
- OCULUS Turkey, info@oculus-turkey.com.tr
- OCULUS USA, sales@oculususa.com

