

REV-201

TWO-CHANNEL ELECTRONIC TIME RELAY

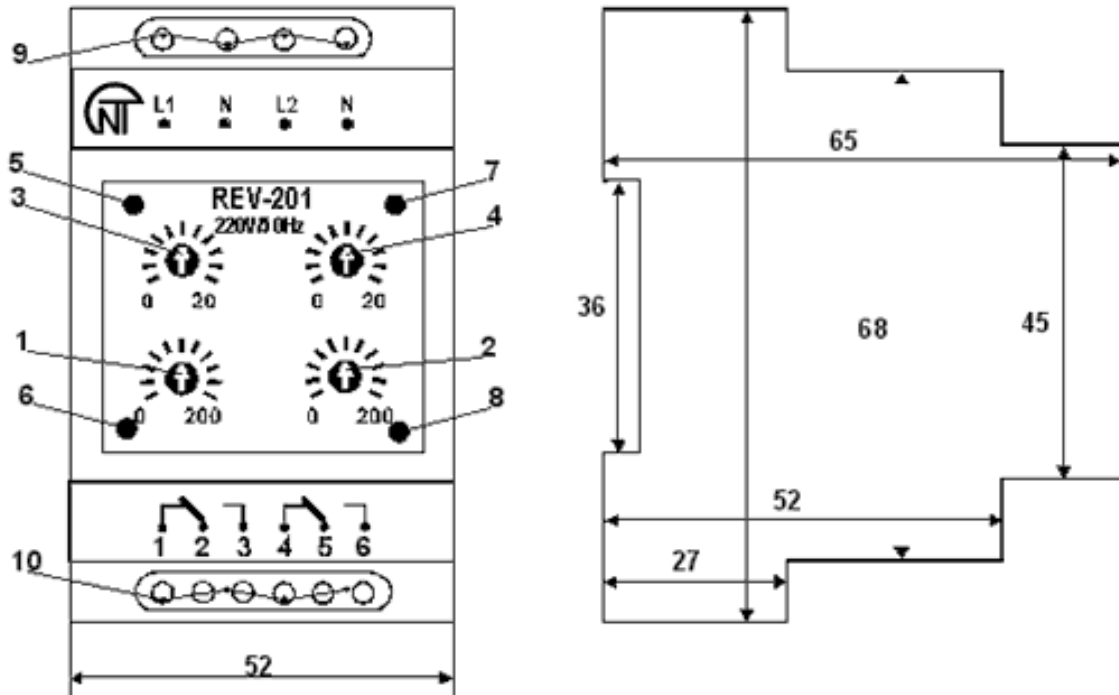

SERVICE MANUAL



- 1, 3 - first-channel trip settings;
- 2, 4 - second-channel trip settings;
- 5, 7 - green LEDs indicating that a voltage is present on the corresponding channel;
- 6, 8 - red LEDs indicating that a corresponding channel trips;
- 9,10 - contacts available for connection.

1 APPLICATIONS

The REV-201 two-channel electronic time delay-on-make relay is designed to switch alternate 220V/50Hz current electric circuits and direct 24 - 100V current electric circuits with adjustable time delay from 0 to 220 sec. The relay has two channels. Each channel represents the independent time delay relay. Time delay for each channel begins when voltage is applied to the channel.

The REV-201 provides three modes of operation:

Mode 1 or the operation mode of two relays. Channels operate independently. The independent voltage is applied to each channel at different times. Time delay begins when each channel is energized.

ATTENTION! In the «operating mode 1» power supply of both channels must use a common neutral.

Mode 2 or the operation mode of one relay with two different delays-on-make. Channels operate in parallel. One and the same power is applied to each channel simultaneously. Time delay-on-make for both channels begins simultaneously. Trip delay corresponds to delays for each channel set by controls.

Mode 3, or the summing channel operation. Power is applied from one channel output to another channel input and thus the summation of the first channel delay and the second channel delay is made.

2 DESCRIPTION

A time delay for each channel begins when a voltage is applied to "L1-N" contacts (channel 1); "L2-N" contacts (channel 2). The time delay is set by contact arms of potentiometers. Two adjustments - in the range from 0 to 20 s and in the range from 0 to 200 s – correspond to each channel. A trip delay of one channel is equal to the sum of the delays set by two potentiometers. If the trip delay is less than

20 s, the 0 - 200 s potentiometer is set in zero position and the delay is set by the 0-20 s potentiometer. If the trip delay is more than 20 s, it is set by both potentiometers as the sum of trip delay settings.

When a voltage is applied to the 1 (2) channel, the green LED of the 1 (2) channel glows. It signals that the time delay begins. Tripping of the relay after the time delay has expired is indicated by glowing of red LED.

Each channel has a N. C. (normally closed) output contact and a N. O. (normally open) output contact: the 1-2 and the 4-5 are N. C. contacts, the 2-3 and the 5-6 are N. O. contacts. The «1-2-3» are the contacts of the 1-st channel, the «4-5-6» are the contacts of the 2-nd channel; both groups are two-way break-before-make contacts.

3 TECHNICAL BRIEF

Nominal supply voltage, V	220
Lower supply voltage threshold, energizing the relay, V	170
Maximum operating supply voltage, V	300
Initial fixed time delay, when supply voltage is 220V, s, not more than	~ 0.5
Accuracy of trip delay hold-in, %, not more than	1.5
Operate value setting accuracy (scale accuracy), %, not more than	3
Adjustable time delay range, seconds	0-220
Time delay adjustment	gradual
Potentiometer graduation marks number	10
Number/type of contacts for each channel (N.O., N.C.; two-way break-before-make contacts)	1 N.O. & 1 N. C
Protection degree:	
• of the relay	IP40
• of the terminal block	IP20
Output contact life:	
• under 5A load, operations, not more than	100 000
• under 1 A load, operations, not more than	1 mln.
Power consumption (under load), VA , not more than	1.0
Weight, kg , not more than	0.150
Case dimensions, mm	50*88*65
Operating temperature range, °C	from -35 to +55
Storage temperature, °C	from -45 to +70

Output contacts specification

	Max. current for ~ 250 V A. C.	Max. power	Max sustained safe voltage ~	Max. current for U = 30V D.C.
Cosφ = 0.4 - 1.0	2A	2000VA	440V	3A

The relay with another time delay adjustment range can be supplied at the customer's request.

The relay can be converted to a periodic «energization-de-energization» mode of operation where «energization-de-energization» cycles are adjusted by user.

Parameters are specified by user additionally.

WIRING DIAGRAM

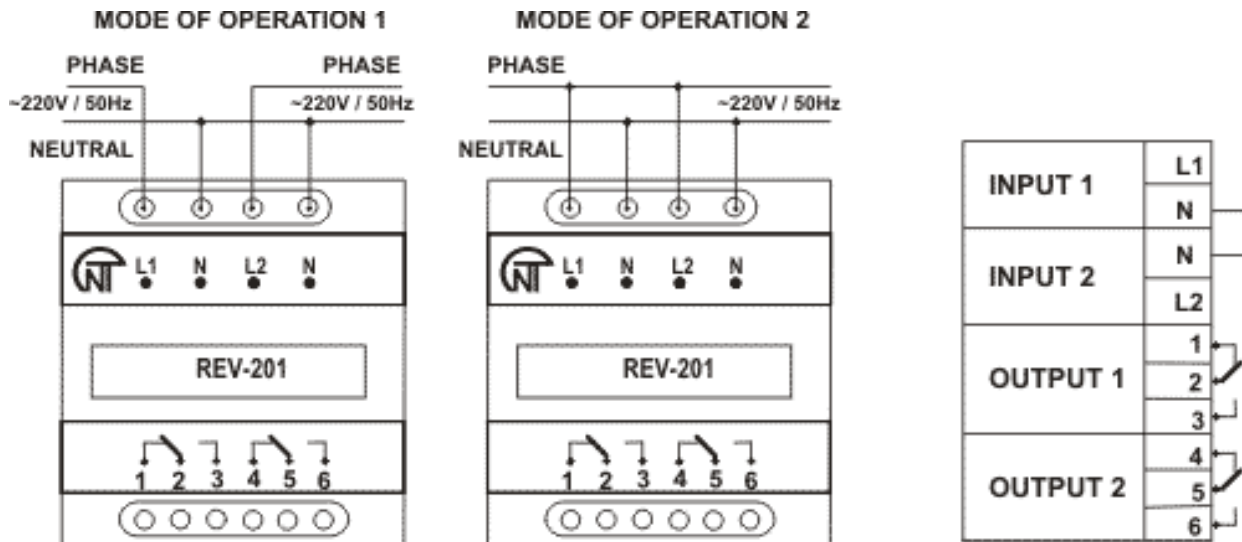

4 STORAGE AND SHIPPING CONDITIONS

The relays in manufacturer package should be stored in enclosed rooms at from -45 to +70 °C and exposed to no more than 80 % of relative humidity when there are no fumes in the air that exert a deleterious effect on package and the relay material.

The Buyer must provide the protection of the relay against mechanical damages in transit.

5 WARRANTY

Novatek-Electro company warrants a trouble-free operation of the REV-201 relay manufactured by it within 36 months from the date of sale, provided:

- the proper connection;
- the safety of the inspection quality control department seal;
- the integrity of the case, no traces of an opening, cracks, spalls etc.