



TEST REPORT

Report No.: DHQA-19MY1591VTSHPB-A1
Test Model: DH-SD5A445XA-HNR
Received: May.07, 2020
ISSUED: May.07, 2020

Applicant: ZHEJIANG DAHUA VISION TECHNOLOGY CO.,
LTD.

Address: No.1199, Bin'an Road, Binjiang District, Hangzhou,
P.R. China

Issued By: BUREAU VERITAS ADT (Shanghai) Corporation

Lab Location: No. 829, Xinzhuan Road, Shanghai, P.R.China
(201612)

This test report consists of 81 pages in total. It may be duplicated completely for legal use with the approval of the applicant. It should not be reproduced except in full, without the written approval of our laboratory. The client should not use it to claim product certification, approval, or endorsement by A2LA, CNAS, or any government agency. The test results in the report only apply to the tested item. The test results in this report are traceable to the national or international standards.





**BUREAU
VERITAS**

Contents

| | |
|---------------------------------------------------------------------|-----------|
| 1. TEST PROGRAM..... | 4 |
| 2. Summary of Test Procedure and Test Results | 5 |
| 3. Immunity Testing Performance Criteria Definition | 8 |
| 4. Test Configuration of Equipment under Test | 9 |
| 4.1. Manufacturer information..... | 9 |
| 4.2. Feature of Equipment under Test..... | 9 |
| 4.3. Model List | 10 |
| 4.4. Description of support units | 10 |
| 4.5. Measurement Uncertainty | 10 |
| 5. Test of Conducted Emission | 11 |
| 5.1. Test Limit | 11 |
| 5.2. Test Procedures | 13 |
| 5.3. Typical Test Setup | 13 |
| 5.4. Measurement Equipment | 14 |
| 5.5. Test Result and Data | 15 |
| 5.6. Test Photographs | 21 |
| 6. Test of Radiated Emission | 22 |
| 6.1. Test Limit | 22 |
| 6.2. Test Procedures | 23 |
| 6.3. Typical Test Setup | 23 |
| 6.4. Measurement Equipment | 24 |
| 6.5. Test Result and Data (30MHz ~ 1GHz)..... | 25 |
| 6.6. Test Result and Data (1GHz ~ 6GHz)..... | 29 |
| 6.7. Test Photographs (30MHz ~ 1000MHz)..... | 33 |
| 6.8. Test Photographs (1000MHz ~ 6000MHz)..... | 34 |
| 7. Electrostatic Discharge Immunity Test..... | 35 |
| 7.1. Test Procedure..... | 35 |
| 7.2. Test Setup for Tests Performed in Laboratory | 36 |
| 7.3. Test Severity Levels | 37 |
| 7.4. Measurement Equipment | 37 |
| 7.5. Test Result and Data | 38 |
| 7.6. Test Photographs | 40 |
| 8. Radio Frequency electromagnetic field immunity test | 42 |
| 8.1. Test Procedure..... | 42 |
| 8.2. Test Severity Levels | 42 |
| 8.3. TEST SETUP..... | 43 |
| 8.4. Measurement Equipment | 44 |
| 8.5. Test Result and Data | 45 |
| 8.6. Test Photographs | 47 |
| 9. Electrical Fast Transient/ Burst Immunity Test | 49 |
| 9.1. Test Procedure..... | 49 |
| 9.2. Test Severity Levels | 49 |
| 9.3. TEST SETUP..... | 50 |
| 9.4. Measurement Equipment | 50 |



| | |
|----------------------------------------------------------------------------|-----------|
| 9.5. Test Result and Data | 51 |
| 9.6. Test Photographs | 53 |
| 10. Surge Immunity Test..... | 54 |
| 10.1. Test Procedure..... | 54 |
| 10.2. Test Severity Level | 54 |
| 10.3. TEST SETUP | 55 |
| 10.4. Measurement Equipment | 55 |
| 10.5. Test Result and Data | 56 |
| 10.6. Test Photographs | 57 |
| 11. Conduction Disturbances induced by Radio-Frequency Fields..... | 58 |
| 11.1. Test Procedure..... | 58 |
| 11.2. Test Severity Levels | 58 |
| 11.3. TEST SETUP..... | 59 |
| 11.4. Measurement Equipment | 59 |
| 11.5. Test Result and Data | 60 |
| 11.6. Test Photographs | 62 |
| 12. Power Frequency Magnetic Field Immunity Test | 63 |
| 12.1. Test Setup..... | 63 |
| 12.2. Test Severity Levels | 63 |
| 12.3. Measurement Equipment | 64 |
| 12.4. Test Result and Data | 65 |
| 12.5. Test Photographs | 66 |
| 13. Voltage Dips and Voltage Interruptions Immunity Test Setup..... | 67 |
| 13.1. Test Conditions | 67 |
| 13.2. TEST SETUP..... | 67 |
| 13.3. Measurement Equipment | 67 |
| 13.4. Test Result and Data | 68 |
| 13.5. Test Photographs | 70 |
| 14. Photographs of EUT | 71 |

2. Summary of Test Procedure and Test Results

| EMISSION | | |
|--------------------------------|----------------------|------------------------------------------------------------------------------------------------------------|
| Test Item | Normative References | Test Result |
| Conducted Emission | EN 55032: 2015 | Meets the Class A requirements |
| Radiated Emission | EN 55032: 2015 | Meets the Class A requirements |
| Harmonic current emissions | EN 61000-3-2: 2014 | The power consumption of EUT is less than 75W, the test item is not applicable. |
| Voltage fluctuations & flicker | EN 61000-3-3: 2013 | According to 6.1 of this standard, the EUT is deemed to comply with this standard without further testing. |

| IMMUNITY (EN 55024:2010+A1:2015) | | |
|-----------------------------------------------------------|-----------------------------------------------------------------------|---------------------------------------------------|
| Test Item | Test Spec | Test Result |
| Electrostatic Discharge Immunity Test (ESD) | ± 4 kV (contact discharge, HCP/VCP) ± 8 kV (Air discharge) | Meets the requirements of Performance Criterion A |
| Radio Frequency electromagnetic field immunity test (RS) | 80-1000 MHz, 3V/m, 80%AM(1KHz) | Meets the requirements of Performance Criterion A |
| Electrical Fast Transient/ Burst Immunity Test (EFT) | AC Port: ± 1 kV, Signal Port: ± 0.5 kV | Meets the requirements of Performance Criterion A |
| Surge Immunity Test | AC Power Ports: Line to Line: ± 1 kV Line to earth: ± 2 kV | Meets the requirements of Performance Criterion A |
| Conduction Disturbances induced by Radio-Frequency Fields | 0.15-80MHz, 3V, 80%AM(1KHz) | Meets the requirements of Performance Criterion A |
| Power Frequency Magnetic Field Immunity Test | 50Hz, 1A/m | Meets the requirements of Performance Criterion A |
| Voltage Dips and Voltage Interruptions Immunity Test | Voltage dips: >95% Reduction, 0.5 Durations (Cycle) | Meets the requirements of Performance Criterion A |
| | 30% Reduction, 25 Durations (Cycle) | Meets the requirements of Performance Criterion A |
| | Voltage interruptions: >95% Reduction, 250 Durations (Cycle) | Meets the requirements of Performance Criterion C |

| IMMUNITY (EN 55035:2017) | | |
|-----------------------------------------------------------|-----------------------------------------------------------------------|---------------------------------------------------|
| Test Item | Test Spec | Test Result |
| Electrostatic Discharge Immunity Test (ESD) | ± 4 kV (contact discharge, HCP/VCP) ± 8 kV (Air discharge) | Meets the requirements of Performance Criterion A |
| Radio Frequency electromagnetic field immunity test (RS) | 80-1000 MHz, 3V/m, 80%AM(1KHz) 1800, 2600, 3500, 5000 | Meets the requirements of Performance Criterion A |
| Electrical Fast Transient/ Burst Immunity Test (EFT) | AC Port: ± 1 kV, Signal Port: ± 0.5 kV | Meets the requirements of Performance Criterion A |
| Surge Immunity Test | AC Power Ports: Line to Line: ± 1 kV Line to earth: ± 2 kV | Meets the requirements of Performance Criterion A |
| Conduction Disturbances induced by Radio-Frequency Fields | 0.15-10MHz, 3V; 10-30MHz, 3-1V 30-80MHz, 1V 80%AM(1KHz) | Meets the requirements of Performance Criterion A |
| Power Frequency Magnetic Field Immunity Test | 50Hz, 1A/m | Meets the requirements of Performance Criterion A |
| Voltage Dips and Voltage Interruptions Immunity Test | Voltage dips: >95% Reduction, 0.5 Durations (Cycle) | Meets the requirements of Performance Criterion A |
| | 30% Reduction, 25 Durations (Cycle) | Meets the requirements of Performance Criterion A |
| | Voltage interruptions: >95% Reduction, 250 Durations (Cycle) | Meets the requirements of Performance Criterion C |

| IMMUNITY (EN 50130-4: 2011+A1: 2014) | | |
|---------------------------------------------------------------------------|-------------------------------------------------------------------------------------------------------------------------------------|---------------------------------------------------|
| Test Item | Test Spec | Test Result |
| EN 61000-4-11 Mains supply voltage variations | Unom+10%(supply voltage max) Unom-15%(supply voltage min) | Meets the requirements of Performance Criterion A |
| EN 61000-4-11 Mains supply voltage dips and short interruptions | Voltage dips: 20% Reduction, 250 Durations (Cycle) 30% Reduction, 25 Durations (Cycle) 60% Reduction, 10 Durations (Cycle) | Meets the requirements of Performance Criterion A |
| | Voltage interruptions: 100% Reduction, 250 Durations (Cycle) | Meets the requirements of Performance Criterion C |
| EN 61000-4-2 Electrostatic Discharge Immunity Test (ESD) | ±6 kV (contact discharge, HCP/VCP) ±8 kV (Air discharge) | Meets the requirements of Performance Criterion A |
| EN 61000-4-3 Radio Frequency electromagnetic field immunity test (RS) | 80-2700MHz, 10V/m, 80%AM(1KHz) 80-2700MHz, 10V/m, 1Hz(0.5s ON, 0.5s OFF) | Meets the requirements of Performance Criterion A |
| EN 61000-4-6 Conduction Disturbances induced by Radio-Frequency Fields | 0.15-100MHz, 10V, 80%AM(1KHz) 0.15-100MHz, 10V, 1Hz(0.5s ON, 0.5s OFF) | Meets the requirements of Performance Criterion A |
| EN 61000-4-4 Electrical Fast Transient/ Burst Immunity Test (EFT) | Pulse : 5/50 ns, Repetition Rate: 100kHz Power line: ±2 kV Signal line: ±1 kV | Meets the requirements of Performance Criterion A |
| EN 61000-4-5 Surge Immunity Test | Waveform : 1.2/50µs(8/20µs) Line to Line: ±1 kV Line to earth: ±2 kV | Meets the requirements of Performance Criterion A |

Special Comment: This report is updated report based on history report DHQA-19MY1591VTSHPB for updating new models. The new models are the same as old models except model names. Compared with standards, no necessary test need. All test results can refer to history report DHQA-19MY1591VTSHPB.

3. Immunity Testing Performance Criteria Definition

- Criterion A : The apparatus operate as intended during the test. No degradation of performance or loss of function is allowed below the performance level.
- Criterion B : The apparatus operate as intended after the test. No change of operating state and the stored data are allowed. During the test, degradation of performance is allowed.
- Criterion C : Temporary loss of function is allowed, provided the function is self-recoverable or can be restored by the operation of the controls, or by any operation specified in the instructions for use.



4. Test Configuration of Equipment under Test

4.1. Manufacturer information

Manufacturer : ZHEJIANG DAHUA VISION TECHNOLOGY CO.,LTD.

Address : No.1199, Bin'an Road, Binjiang District, Hangzhou, P.R. China

4.2. Feature of Equipment under Test

| | |
|---------------------------|--------------------------------------------------------|
| Product Name: | NETWORK PTZ CAMERA |
| Test Model: | DH-SD5A445XA-HNR |
| Series Model: | Refer to model list |
| Model Discrepancy: | All models just have different pixels and model names. |
| EUT Power Rating: | 24VAC/3A; POE(802.3at) |

Note: Please refer to user manual.

4.3. Model List

Test Model: DH-SD5A445XA-HNR

Series Model: SD5A432XA-HNR; SD5A432XAN-HNR; DH-SD5A432XA-HNR;

DH-SD5A432XAN-HNR; SD5A232XA-HNR; SD5A232XAN-HNR; DH-SD5A232XA-HNR;

DH-SD5A232XAN-HNR; SD5A445XA-HNR; SD5A445XAN-HNR; DH-SD5A445XA-HNR;

DH-SD5A445XAN-HNR; SD5A245XA-HNR; SD5A245XAN-HNR; DH-SD5A245XA-HNR;

DH-SD5A245XAN-HNR; SD5A225XA-HNR; SD5A225XAN-HNR; DH-SD5A225XA-HNR;

DH-SD5A225XAN-HNR; SD5A425XA-HNR; SD5A425XAN-HNR; DH-SD5A425XA-HNR;

DH-SD5A425XAN-HNR; SD5A825-HNR-YA; SD5A825N-HNR-YA; DH-SD5A825-HNR-YA;

DH-SD5A825N-HNR-YA; 5Axyzuabc (x=1-9 or blank; y=1-9 or blank; z=1-9 or blank; u=A-Z or

blank; a=A-Z or blank; b=A-Z or blank; c=A-Z or blank); SD5Aaczutm-Hxb; DH-SD5Aaczutm-Hxb

(a= 0-9 or blank; c= 0-9; z= 0-9; u= A-Z ;t= A-Z or blank m= N; P or blank; x= C; N or blank; b= I; R; F; P or blank)

4.4. Description of support units

| NO. | PRODUCT | BRAND | MODEL NO. |
|-----|---------------|-----------|----------------|
| 1 | PC | Lenovo | Thinkpad L470 |
| 2 | AC adapter | Hon-Kwang | HKA-A24300-230 |
| 3 | Network Cable | -- | -- |
| 4 | POE injector | TP-LINK | TL-POE150S |

4.5. Measurement Uncertainty

Where relevant, the following measurement uncertainty levels have been estimated for tests performed on the EUT as specified in CISPR 16-4-2 Ed 1.0.

This uncertainty represents an expanded uncertainty expressed at approximately the 95% confidence level using a coverage factor of k=2.

This lab's measurement uncertainty U_{Lab}, is low than UC_{ispr}, Table 1 – Values of UC_{ispr} of CISPR 16-4-2 Ed. 1.0, therefore compliance is deemed to occur if no measured disturbance exceeds the disturbance limit.

| Measurement | | Value |
|-------------------------------------|---------------|---------|
| Conducted emissions | | 2.55 dB |
| Conducted emissions at telecom port | | 2.60 dB |
| Radiated emissions | 30 MHz ~ 1GHz | 3.22 dB |
| | Above 1GHz | 2.89 dB |

5. Test of Conducted Emission

5.1. Test Limit

Conducted Emissions were measured from 150 kHz to 30 MHz with a bandwidth of 9 kHz and return leads of the EUT according to the methods defined in European Standard EN 55032.

Table A.9 – Requirements for conducted emissions from the AC mains power ports of Class A equipment

| Applicable to 1. AC mains power ports (3.1.1) | | | | |
|--------------------------------------------------------|------------------------|------------------------------------|------------------------------|--------------------------|
| Table clause | Frequency range MHz | Coupling device (see Table A.8) | Detector type / bandwidth | Class A limits dB(uV) |
| A9.1 | 0,15 to 0,5 | AMN | Quasi Peak / 9 kHz | 79 |
| | 0,5 to 30 | | | 73 |
| A9.2 | 0,15 to 0,5 | AMN | Average / 9 kHz | 66 |
| | 0,5 to 30 | | | 60 |
| Apply A9.1 and A9.2 across the entire frequency range. | | | | |

Table A.11 –Requirements for asymmetric mode conducted emissions from Class A equipment

| Applicable to | | | | | |
|-------------------------------------------------------------------------|---------------------|---------------------------------|---------------------------|-------------------------------|-------------------------------|
| 1. wired network ports (3.1.32) | | | | | |
| 2. optical fibre ports (3.1.25) with metallic shield or tension members | | | | | |
| 3. antenna ports (3.1.3) | | | | | |
| Table clause | Frequency range MHz | Coupling device (see Table A.8) | Detector type / bandwidth | Class A voltage limits dB(uV) | Class A current limits dB(uA) |
| A11.1 | 0,15 to 0,5 | AAN | Quasi Peak / 9 kHz | 97 to 87 | n/a |
| | 0,5 to 30 | | | 87 | |
| | 0,15 to 0,5 | AAN | Average / 9 kHz | 84 to 74 | |
| | 0,5 to 30 | | | 74 | |
| A11.2 | 0,15 to 0,5 | CVP and current probe | Quasi Peak / 9 kHz | 97 to 87 | 53 to 43 |
| | 0,5 to 30 | | | 87 | 43 |
| | 0,15 to 0,5 | CVP and current probe | Average / 9 kHz | 84 to 74 | 40 to 30 |
| | 0,5 to 30 | | | 74 | 30 |
| A11.3 | 0,15 to 0,5 | Current Probe | Quasi Peak / 9 kHz | n/a | 53 to 43 |
| | 0,5 to 30 | | | | 43 |
| | 0,15 to 0,5 | Current Probe | Average / 9 kHz | | 40 to 30 |
| | 0,5 to 30 | | | | 30 |

The choice of coupling device and measurement procedure is defined in Annex C.
AC mains ports that also have the function of a wired network port shall meet the limits given in Table A.9.
The measurement shall cover the entire frequency range.
The application of the voltage and/or current limits is dependent on the measurement procedure used. Refer to Table C.1 for applicability.
Testing is required at only one EUT supply voltage and frequency.
Applicable to ports listed above and intended to connect to cables longer than 3 m.

5.4. Measurement Equipment

| DESCRIPTION & MANUFACTURER | MODEL NO. | SERIAL NO. | CALIBRATED UNTIL |
|----------------------------------|-----------------|------------|------------------|
| Test Receiver ROHDE & SCHWARZ | ESCS30 | E1R1001 | Mar.04, 2020 |
| LISN ROHDE & SCHWARZ | ENV216 | E1L1011 | Jul.18, 2019 |
| LISN | ISNT800 | E1C4021 | Sep.19, 2019 |
| Software ADT | ADT_Cond_V7.3.0 | N/A | N/A |

5.5. Test Result and Data

5.5.1 Conducted Emission Test Data

For AC24V port test on AC adapter

Phase : LINE

Location: Conduction 1

Date: 5/29/2019

Time: 10:38:14 AM

Phase L1

Temperatuer (C): 22

Humidity (%): 48

Approved by:

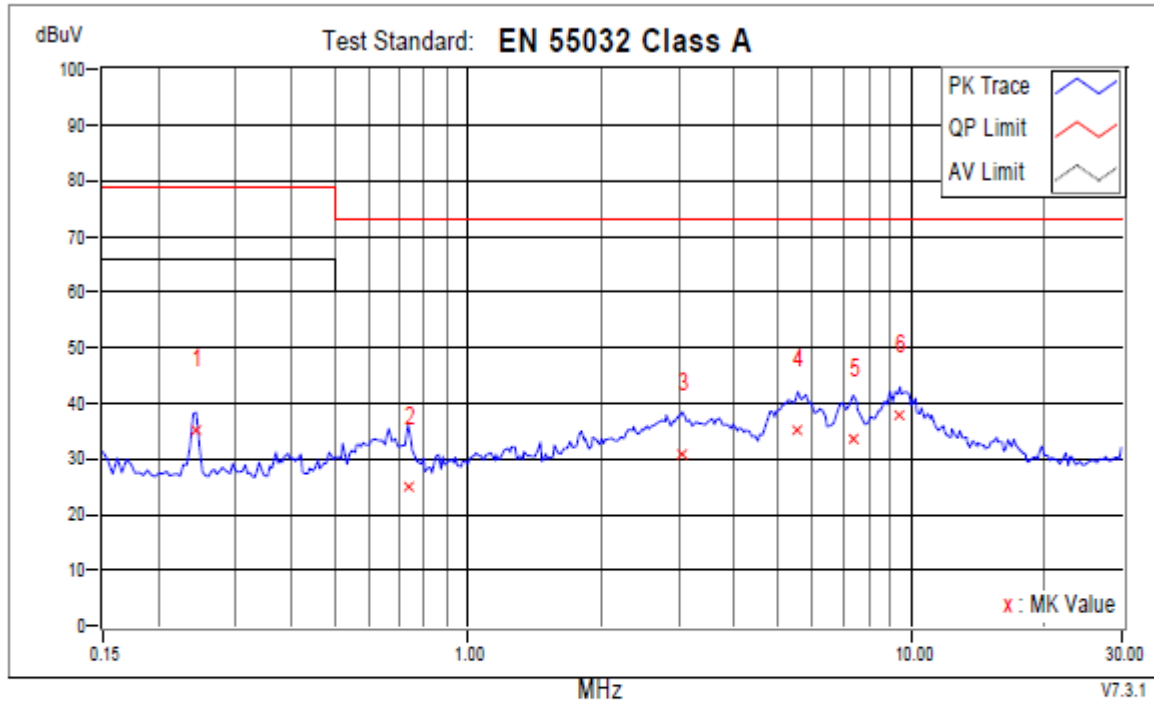

| No. | Frequency MHz | Corr. Factor dB | Reading dBuV | | Emission dBuV | | Limit dBuV | | Margins dB | | Notes |
|-----|------------------|-----------------------|-----------------|-------|------------------|-------|---------------|-------|---------------|--------|-------|
| | | | QP | AV | QP | AV | QP | AV | QP | AV | |
| 1 | 0.24384 | 9.82 | 25.26 | 24.72 | 35.08 | 34.54 | 79.00 | 66.00 | -43.92 | -31.46 | |
| 2 | 0.73259 | 9.63 | 15.44 | 2.93 | 25.07 | 12.56 | 73.00 | 60.00 | -47.93 | -47.44 | |
| 3 | 3.04493 | 9.90 | 20.90 | 8.19 | 30.80 | 18.09 | 73.00 | 60.00 | -42.20 | -41.91 | |
| 4 | 5.55124 | 10.12 | 25.16 | 14.06 | 35.28 | 24.18 | 73.00 | 60.00 | -37.72 | -35.82 | |
| 5 | 7.39676 | 10.25 | 23.44 | 15.12 | 33.69 | 25.37 | 73.00 | 60.00 | -39.31 | -34.63 | |
| +6 | 9.44560 | 10.39 | 27.36 | 22.58 | 37.75 | 32.97 | 73.00 | 60.00 | -35.25 | -27.03 | |

REMARKS:

1. Q.P. and AV. are abbreviations of quasi-peak and average individually.
2. The emission levels of other frequencies were very low against the limit.
3. Margin value = Emission level - Limit value
4. Correction factor = Insertion loss + Cable loss
5. Emission Level = Correction Factor + Reading Value.

Phase : NEUTRAL

Location: Conduction 1

Date: 5/29/2019

Time: 10:45:01 AM

Phase N

Temperatuer (C): 22

Humidity (%): 48

Approved by:

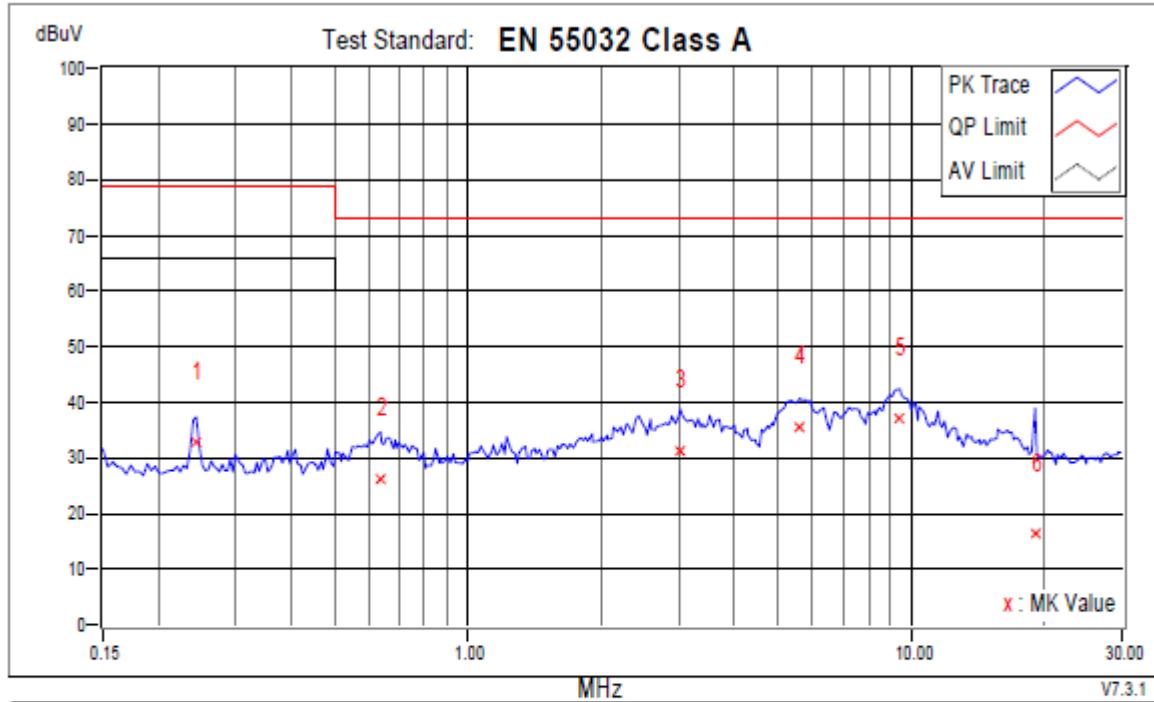

| No. | Frequency MHz | Corr. Factor dB | Reading dBuV | | Emission dBuV | | Limit dBuV | | Margins dB | | Notes |
|-----|------------------|-----------------------|-----------------|-------|------------------|-------|---------------|-------|---------------|--------|-------|
| | | | QP | AV | QP | AV | QP | AV | QP | AV | |
| 1 | 0.24384 | 9.86 | 22.98 | 22.36 | 32.84 | 32.22 | 79.00 | 66.00 | -46.16 | -33.78 | |
| 2 | 0.63484 | 9.85 | 16.30 | 4.47 | 26.15 | 14.32 | 73.00 | 60.00 | -46.85 | -45.68 | |
| 3 | 3.01756 | 10.06 | 21.36 | 8.62 | 31.42 | 18.68 | 73.00 | 60.00 | -41.58 | -41.32 | |
| 4 | 5.60989 | 9.88 | 25.48 | 14.61 | 35.36 | 24.49 | 73.00 | 60.00 | -37.64 | -35.51 | |
| +5 | 9.44169 | 10.40 | 26.66 | 21.97 | 37.06 | 32.37 | 73.00 | 60.00 | -35.94 | -27.63 | |
| 6 | 19.04383 | 10.41 | 6.02 | -1.89 | 16.43 | 8.52 | 73.00 | 60.00 | -56.57 | -51.48 | |

REMARKS:

1. Q.P. and AV. are abbreviations of quasi-peak and average individually.
2. The emission levels of other frequencies were very low against the limit.
3. Margin value = Emission level - Limit value
4. Correction factor = Insertion loss + Cable loss
5. Emission Level = Correction Factor + Reading Value.

LAN Port

Location: Conduction 1

Date: 6/4/2019

Time: 1:43:41 PM

Phase Factor

Temperatuer (C): 22

Humidity (%): 48

Approved by:

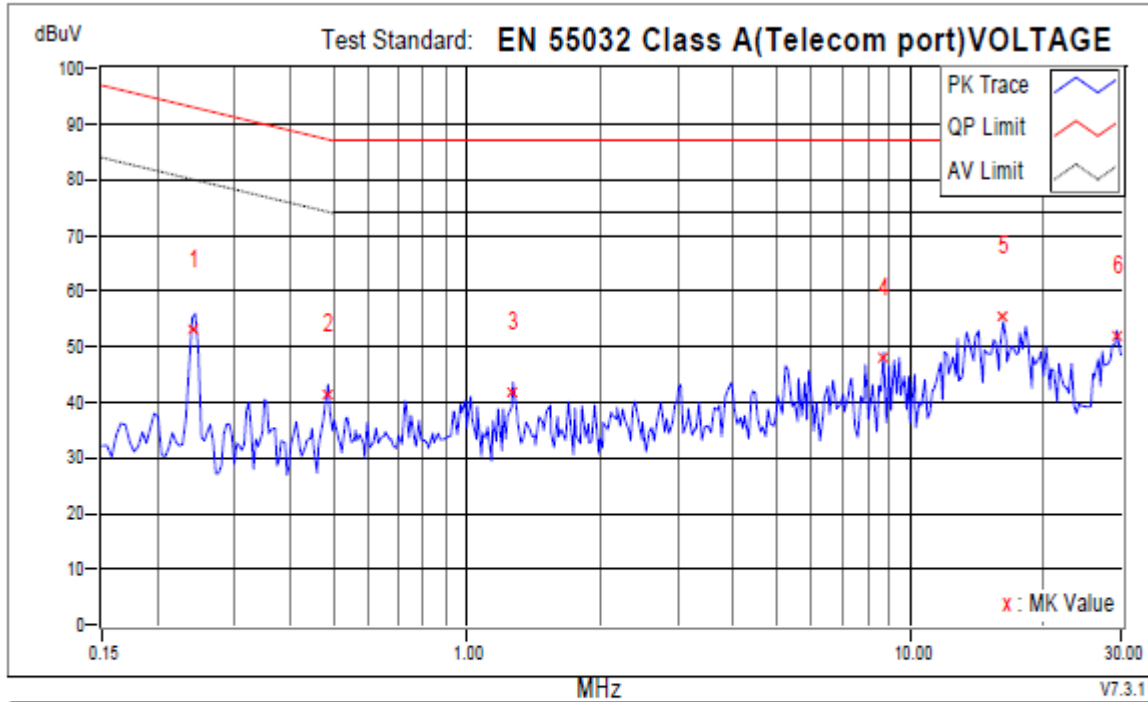

| No. | Frequency MHz | Corr. Factor dB | Reading dBuV | | Emission dBuV | | Limit dBuV | | Margins dB | | Notes |
|-----|------------------|-----------------------|-----------------|-------|------------------|-------|---------------|-------|---------------|--------|-------|
| | | | QP | AV | QP | AV | QP | AV | QP | AV | |
| 1 | 0.23993 | 10.01 | 43.18 | 41.31 | 53.19 | 51.32 | 93.10 | 80.10 | -39.91 | -28.78 | |
| 2 | 0.48626 | 9.92 | 31.58 | 30.78 | 41.50 | 40.70 | 87.23 | 74.23 | -45.74 | -33.54 | |
| 3 | 1.26979 | 9.63 | 32.00 | 29.93 | 41.63 | 39.56 | 87.00 | 74.00 | -45.37 | -34.44 | |
| 4 | 8.71834 | 9.62 | 38.48 | 34.79 | 48.10 | 44.41 | 87.00 | 74.00 | -38.90 | -29.59 | |
| +5 | 16.22863 | 9.70 | 45.62 | 43.75 | 55.32 | 53.45 | 87.00 | 74.00 | -31.68 | -20.55 | |
| 6 | 29.23329 | 9.83 | 42.18 | 38.90 | 52.01 | 48.73 | 87.00 | 74.00 | -34.99 | -25.27 | |

REMARKS:

1. Q.P. and AV. are abbreviations of quasi-peak and average individually.
2. The emission levels of other frequencies were very low against the limit.
3. Margin value = Emission level - Limit value
4. Correction factor = Insertion loss + Cable loss
5. Emission Level = Correction Factor + Reading Value.

For POE port test on POE adapter

Phase : LINE

Location: Conduction 1

Date: 6/4/2019

Time: 11:42:40 AM

Phase L1

Temperatuer (C): 22

Humidity (%): 48

Approved by:

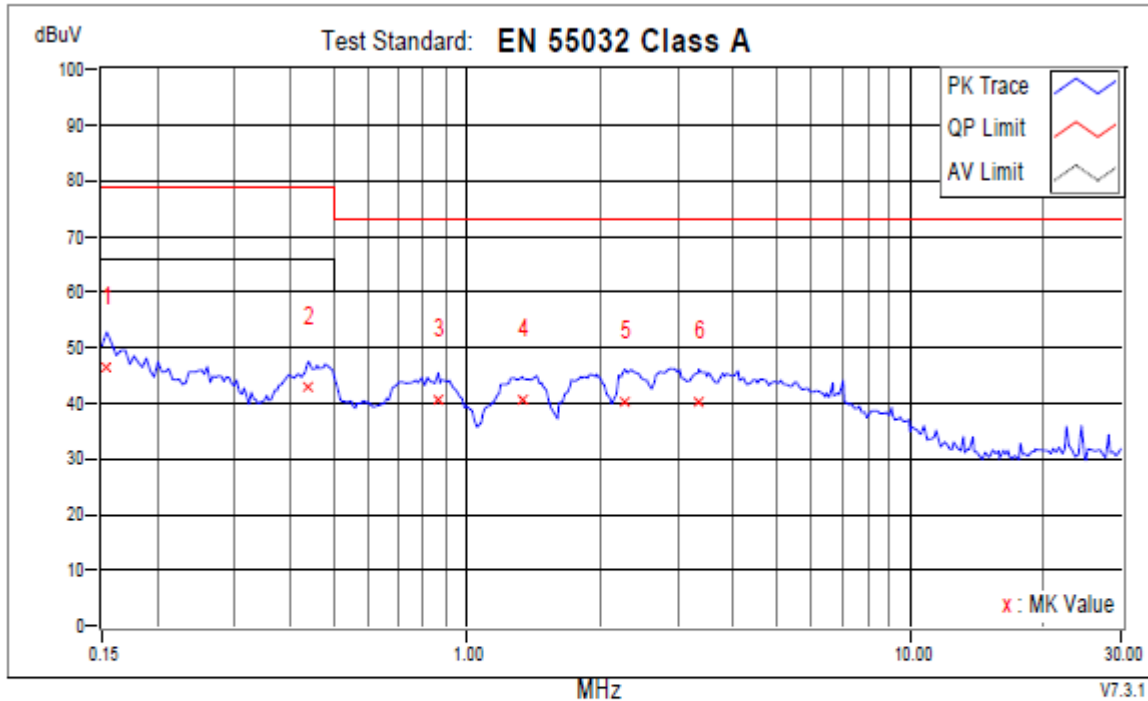

| No. | Frequency MHz | Corr. Factor dB | Reading dBuV | | Emission dBuV | | Limit dBuV | | Margins dB | | Notes |
|-----|------------------|-----------------------|-----------------|-------|------------------|-------|---------------|-------|---------------|--------|-------|
| | | | QP | AV | QP | AV | QP | AV | QP | AV | |
| 1 | 0.15391 | 9.86 | 36.80 | 21.83 | 46.66 | 31.69 | 79.00 | 66.00 | -32.34 | -34.31 | |
| 2 | 0.43934 | 9.73 | 33.18 | 24.64 | 42.91 | 34.37 | 79.00 | 66.00 | -36.09 | -31.63 | |
| 3 | 0.86162 | 9.61 | 30.88 | 24.56 | 40.49 | 34.17 | 73.00 | 60.00 | -32.51 | -25.83 | |
| +4 | 1.33235 | 9.67 | 31.08 | 25.74 | 40.75 | 35.41 | 73.00 | 60.00 | -32.25 | -24.59 | |
| 5 | 2.27075 | 9.79 | 30.46 | 24.47 | 40.25 | 34.26 | 73.00 | 60.00 | -32.75 | -25.74 | |
| 6 | 3.33427 | 9.82 | 30.38 | 23.67 | 40.20 | 33.49 | 73.00 | 60.00 | -32.80 | -26.51 | |

REMARKS:

1. Q.P. and AV. are abbreviations of quasi-peak and average individually.
2. The emission levels of other frequencies were very low against the limit.
3. Margin value = Emission level - Limit value
4. Correction factor = Insertion loss + Cable loss
5. Emission Level = Correction Factor + Reading Value.

Phase : NEUTRAL

Location: Conduction 1

Date: 6/4/2019

Time: 11:45:25 AM

Phase N

Temperatuer (C): 22

Humidity (%): 48

Approved by:

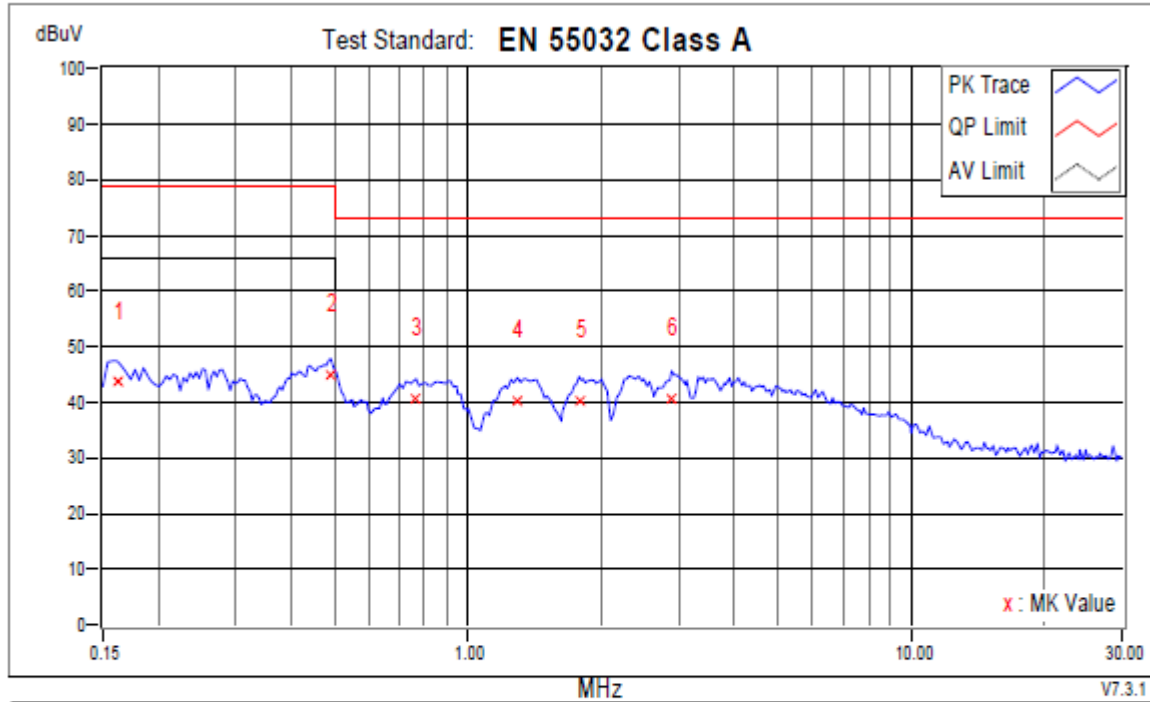

| No. | Frequency | Corr. Factor | Reading dBuV | | Emission dBuV | | Limit dBuV | | Margins dB | | Notes |
|-----|-----------|--------------|--------------|-------|---------------|-------|------------|-------|------------|--------|-------|
| | MHz | | QP | AV | QP | AV | QP | AV | QP | AV | |
| 1 | 0.16173 | 9.86 | 34.00 | 16.71 | 43.86 | 26.57 | 79.00 | 66.00 | -35.14 | -39.43 | |
| 2 | 0.49017 | 9.86 | 35.18 | 27.76 | 45.04 | 37.62 | 79.00 | 66.00 | -33.96 | -28.38 | |
| 3 | 0.76387 | 9.88 | 30.74 | 24.13 | 40.62 | 34.01 | 73.00 | 60.00 | -32.38 | -25.99 | |
| 4 | 1.29325 | 9.93 | 30.42 | 25.05 | 40.35 | 34.98 | 73.00 | 60.00 | -32.65 | -25.02 | |
| 5 | 1.78200 | 9.94 | 30.16 | 25.05 | 40.10 | 34.99 | 73.00 | 60.00 | -32.90 | -25.01 | |
| +6 | 2.88071 | 9.98 | 30.46 | 25.36 | 40.44 | 35.34 | 73.00 | 60.00 | -32.56 | -24.66 | |

REMARKS:

1. Q.P. and AV. are abbreviations of quasi-peak and average individually.
2. The emission levels of other frequencies were very low against the limit.
3. Margin value = Emission level - Limit value
4. Correction factor = Insertion loss + Cable loss
5. Emission Level = Correction Factor + Reading Value.

LAN Port

Location: Conduction 1 Date: 6/4/2019 Time: 11:32:23 AM Phase Factor
 Temperatur (C): 22 Humidity (%): 48 Approved by:

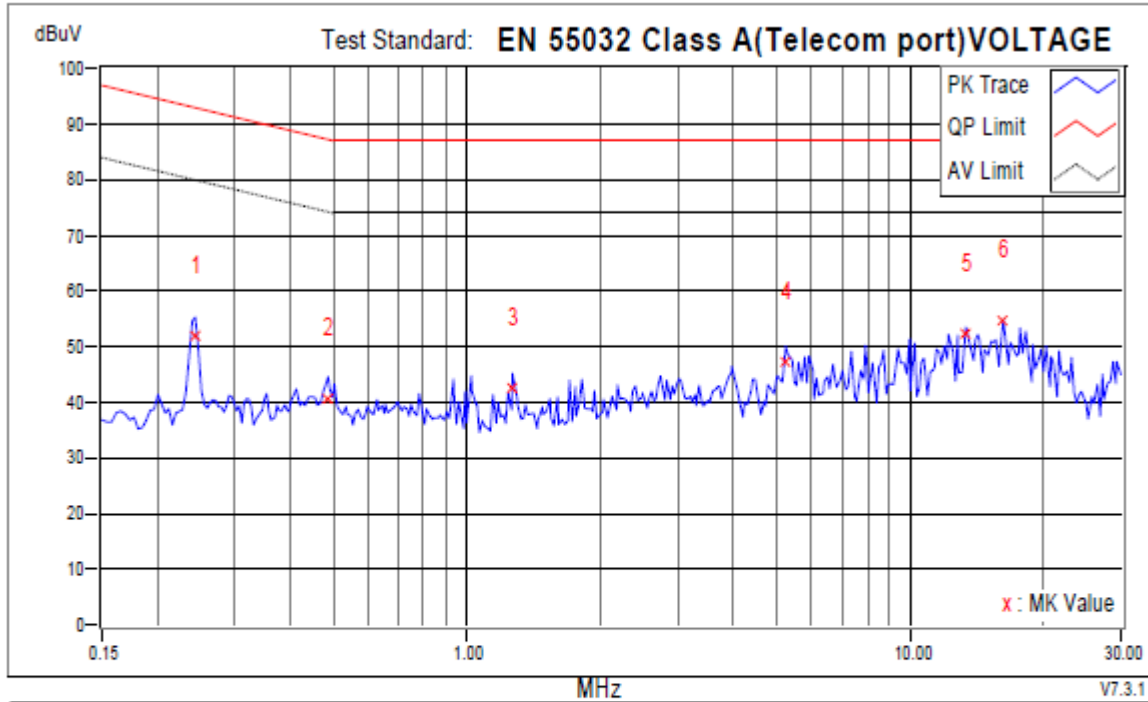

| No. | Frequency MHz | Corr. Factor dB | Reading dBuV | | Emission dBuV | | Limit dBuV | | Margins dB | | Notes |
|-----|------------------|-----------------------|-----------------|-------|------------------|-------|---------------|-------|---------------|--------|-------|
| | | | QP | AV | QP | AV | QP | AV | QP | AV | |
| 1 | 0.24384 | 10.01 | 42.12 | 41.51 | 52.13 | 51.52 | 92.96 | 79.96 | -40.84 | -28.45 | |
| 2 | 0.48626 | 9.92 | 30.84 | 26.15 | 40.76 | 36.07 | 87.23 | 74.23 | -46.48 | -38.17 | |
| 3 | 1.26588 | 9.63 | 33.04 | 30.24 | 42.67 | 39.87 | 87.00 | 74.00 | -44.33 | -34.13 | |
| 4 | 5.23844 | 9.58 | 37.58 | 34.64 | 47.16 | 44.22 | 87.00 | 74.00 | -39.84 | -29.78 | |
| 5 | 13.35869 | 9.66 | 42.72 | 39.17 | 52.38 | 48.83 | 87.00 | 74.00 | -34.62 | -25.17 | |
| +6 | 16.22863 | 9.70 | 44.80 | 41.31 | 54.50 | 51.01 | 87.00 | 74.00 | -32.50 | -22.99 | |

REMARKS:

1. Q.P. and AV. are abbreviations of quasi-peak and average individually.
2. The emission levels of other frequencies were very low against the limit.
3. Margin value = Emission level - Limit value
4. Correction factor = Insertion loss + Cable loss
5. Emission Level = Correction Factor + Reading Value.

5.6. Test Photographs

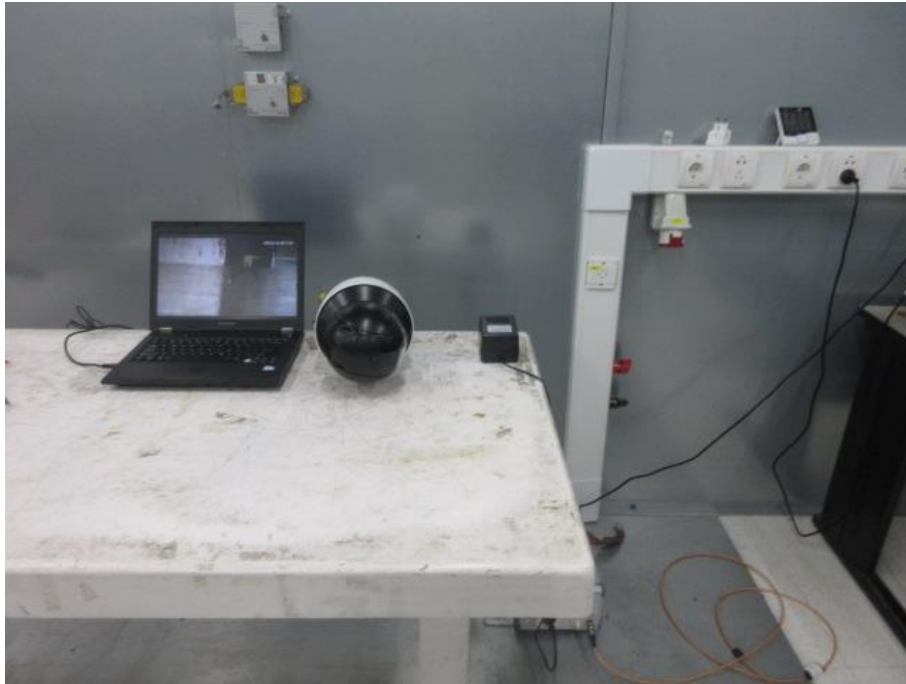

6. Test of Radiated Emission

6.1. Test Limit

The EUT shall meet the limits of below Table when measured at the measuring distance R in accordance with the methods described in European Standard EN 55032. If the reading on the measuring receiver shows fluctuations close to the limit, the reading shall be observed for at least 15 s at each measurement frequency; the highest reading shall be recorded, with the exception of any brief isolated high reading, which shall be ignored.

Table A.4 – Requirements for radiated emissions at frequencies up to 1 GHz for class A equipment

| Table clause | Frequency range MHz | Measurement | | | Class A limits dB(uV/m) |
|--------------|---------------------|--------------------------|------------|---------------------------|-------------------------|
| | | Facility (see Table A.1) | Distance m | Detector type / bandwidth | |
| A2.1 | 30 to 230 | OATS/SAC | 10 | Quasi Peak / 120 kHz | 40 |
| | 230 to 1000 | | | | 47 |
| A2.2 | 30 to 230 | OATS/SAC | 3 | | 50 |
| | 230 to 1000 | | | | 57 |
| A2.3 | 30 to 230 | FAR | 10 | | 42 to 35 |
| | 230 to 1000 | | | | 42 |
| A2.4 | 30 to 230 | FAR | 3 | | 52 to 45 |
| | 230 to 1000 | | | | 52 |

Apply only A2.1 or A2.2 or A2.3 or A2.4 across the entire frequency range.

Table A.5 – Requirements for radiated emissions at frequencies above 1 GHz for class A equipment

| Table clause | Frequency range MHz | Measurement | | | Class A limits dB(uV/m) |
|--------------|---------------------|--------------------------|------------|---------------------------|-------------------------|
| | | Facility (see Table A.1) | Distance m | Detector type / bandwidth | |
| A3.1 | 1000-3000 | FSOATS | 10 | Average / 1 MHz | 56 |
| | 3000-6000 | | | | 50 |
| A3.2 | 1000-3000 | | 3 | Peak / 1 MHz | 76 |
| | 3000-6000 | | | | 80 |

Apply A3.1 and A3.2 across the frequency range from 1 000 MHz to the highest required frequency of measurement derived from Table 1.

6.2. Test Procedures

- a. The EUT was placed on a rotatable table top 0.8 meter above ground.
- b. The EUT was set 3/10 meters from the interference receiving antenna which was mounted on the top of a variable height antenna tower.
- c. The table was rotated 360 degrees to determine the position of the highest radiation.
- d. The antenna is a half wave dipole and its height is varied between one meter and four meters above ground to find the maximum value of the field strength both horizontal polarization and vertical polarization of the antenna are set to make the measurement.
- e. For each suspected emission the EUT was arranged to its worst case and then tune the antenna tower (from 1 M to 4 M) and turn table (from 0 degree to 360 degrees) to find the maximum reading.
- f. Set the test-receiver system to Peak Detect Function and specified bandwidth with Maximum Hold Mode.
- g. If the emission level of the EUT in peak mode was 3 dB lower than the limit specified, then testing will be stopped and peak values of EUT will be reported, otherwise, the emissions which do not have 3 dB margin will be repeated one by one using the quasi-peak method and reported.

6.3. Typical Test Setup

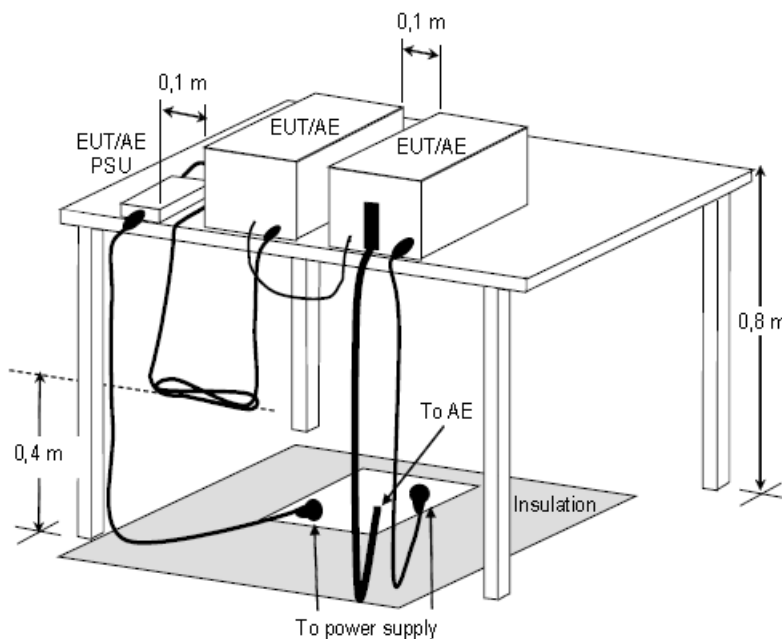

**Figure D.8 – Example measurement arrangement for table-top EUT
(Radiated emission measurement)**

6.4. Measurement Equipment

| DESCRIPTION & MANUFACTURER | MODEL NO. | SERIAL NO. | CALIBRATED UNTIL |
|--------------------------------------------------------|-------------|------------|------------------|
| EMI Test Spectrum ROHDE & SCHWARZ | ESR7 | E1R1005 | Dec.03, 2019 |
| Spectrum Analyzer Keysight | N9030B | E1S1003 | Jun.23, 2019 |
| Broad-Band Antenna Schwarzbeck | VULB9168 | E1A1012 | Aug.26, 2019 |
| Double Riaged Vroadband Horn Antenna Schwarzbeck | BBHA9120D | E1A1017 | Jan.26, 2020 |
| Preamplifier Agilent | 8447D | E1A2001 | Oct.14, 2019 |
| Preamplifier Agilent | EMC051845SE | E1A2009 | Jun.19, 2019 |

6.5. Test Result and Data (30MHz ~ 1GHz)

For AC24V port test on AC adapter

Position: Horizontal

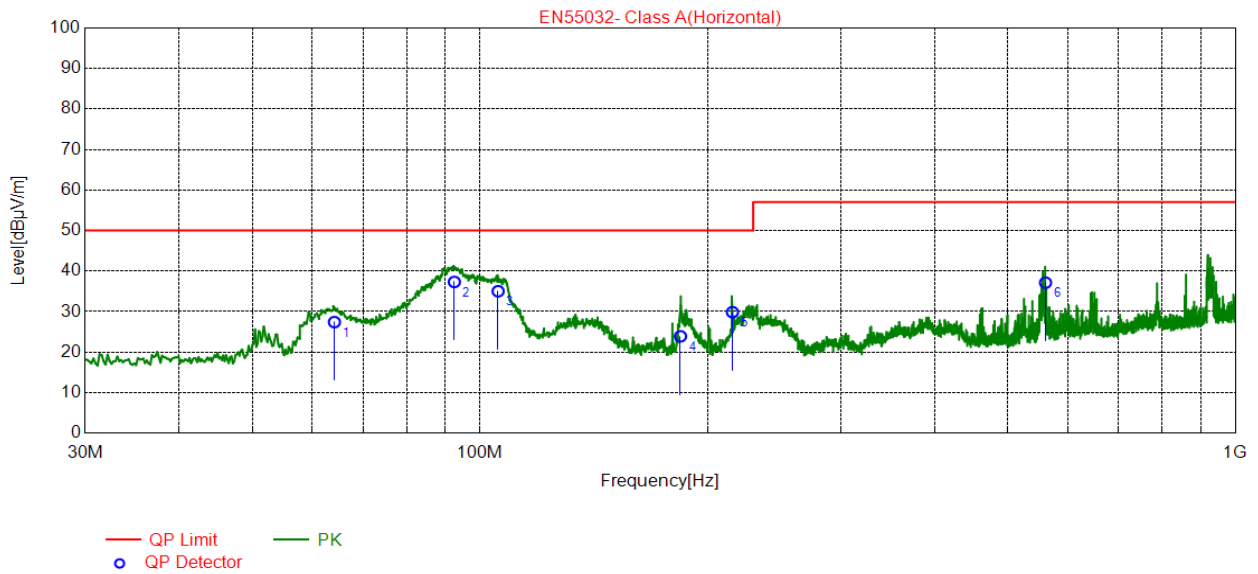

| NO. | Freq. [MHz] | QP Reading [dB µ V/m] | Factor [dB] | QP Value [dB µ V/m] | QP Limit [dB µ V/m] | QP Margin [dB] | Height [cm] | Angle [°] | Polarity |
|-----|-------------|-----------------------|-------------|---------------------|---------------------|----------------|-------------|-----------|------------|
| 1 | 64.144 | 38.61 | -11.20 | 27.41 | 50.00 | 22.59 | 200 | 167 | Horizontal |
| 2 | 92.468 | 51.57 | -14.25 | 37.32 | 50.00 | 12.68 | 200 | 205 | Horizontal |
| 3 | 105.66 | 47.71 | -12.68 | 35.03 | 50.00 | 14.97 | 200 | 193 | Horizontal |
| 4 | 184.23 | 35.59 | -11.68 | 23.91 | 50.00 | 26.09 | 200 | 101 | Horizontal |
| 5 | 215.85 | 41.51 | -11.65 | 29.86 | 50.00 | 20.14 | 100 | 262 | Horizontal |
| 6 | 560.59 | 42.31 | -5.17 | 37.14 | 57.00 | 19.86 | 200 | 20 | Horizontal |

REMARKS:

1. Q.P. is abbreviation of quasi-peak individually.
2. The emission levels of other frequencies were very low against the limit.
3. QP Margin value = QP Limit value – QP value
4. Factor = Antenna Factor + Amplifier Factor + Cable loss
5. QP value = Factor + Reading Value.

Position: Vertical

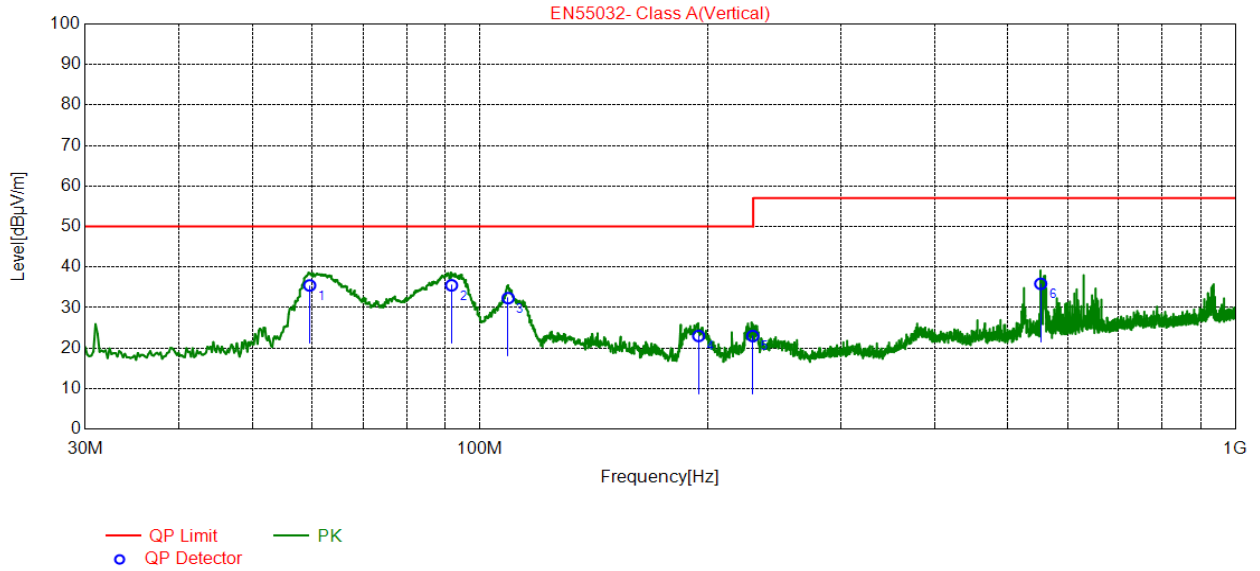

| NO. | Freq. [MHz] | QP Reading [dB µ V/m] | Factor [dB] | QP Value [dB µ V/m] | QP Limit [dB µ V/m] | QP Margin [dB] | Height [cm] | Angle [°] | Polarity |
|-----|-------------|-----------------------|-------------|---------------------|---------------------|----------------|-------------|-----------|----------|
| 1 | 59.488 | 45.97 | -10.51 | 35.46 | 50.00 | 14.54 | 100 | 245 | Vertical |
| 2 | 91.692 | 49.82 | -14.33 | 35.49 | 50.00 | 14.51 | 200 | 147 | Vertical |
| 3 | 108.95 | 44.57 | -12.23 | 32.34 | 50.00 | 17.66 | 100 | 17 | Vertical |
| 4 | 194.70 | 35.13 | -12.13 | 23.00 | 50.00 | 27.00 | 100 | 120 | Vertical |
| 5 | 229.62 | 34.12 | -11.13 | 22.99 | 50.00 | 27.01 | 100 | 274 | Vertical |
| 6 | 552.44 | 41.06 | -5.19 | 35.87 | 57.00 | 21.13 | 100 | 20 | Vertical |

REMARKS:

1. Q.P. is abbreviation of quasi-peak individually.
2. The emission levels of other frequencies were very low against the limit.
3. QP Margin value = QP Limit value – QP value
4. Factor = Antenna Factor + Amplifier Factor + Cable loss
5. QP value = Factor + Reading Value.

For POE port test on POE adapter
Position: Horizontal

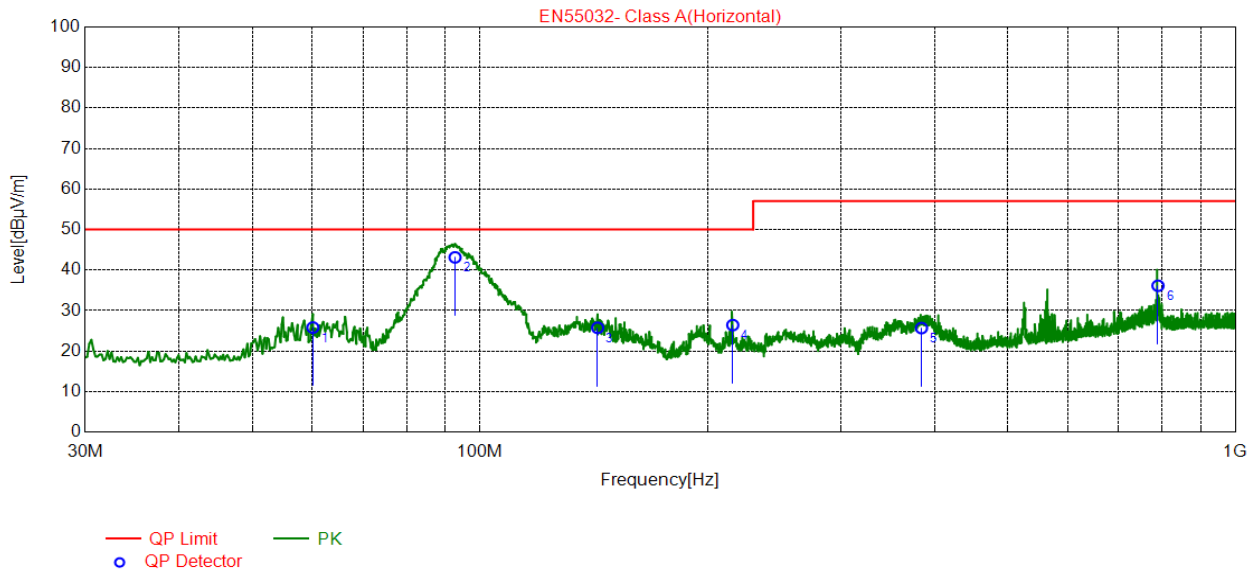

| NO. | Freq. [MHz] | QP Reading [dB µ V/m] | Factor [dB] | QP Value [dB µ V/m] | QP Limit [dB µ V/m] | QP Margin [dB] | Height [cm] | Angle [°] | Polarity |
|-----|-------------|-----------------------|-------------|---------------------|---------------------|----------------|-------------|-----------|------------|
| 1 | 60.070 | 36.38 | -10.56 | 25.82 | 50.00 | 24.18 | 100 | 17 | Horizontal |
| 2 | 92.662 | 57.37 | -14.23 | 43.14 | 50.00 | 6.86 | 200 | 213 | Horizontal |
| 3 | 143.10 | 35.66 | -9.90 | 25.76 | 50.00 | 24.24 | 200 | 106 | Horizontal |
| 4 | 216.04 | 38.06 | -11.64 | 26.42 | 50.00 | 23.58 | 100 | 96 | Horizontal |
| 5 | 384.05 | 33.5 | -7.82 | 25.68 | 57.00 | 31.32 | 100 | 285 | Horizontal |
| 6 | 789.89 | 37.5 | -1.36 | 36.14 | 57.00 | 20.86 | 100 | 223 | Horizontal |

REMARKS:

1. Q.P. is abbreviation of quasi-peak individually.
2. The emission levels of other frequencies were very low against the limit.
3. QP Margin value = QP Limit value – QP value
4. Factor = Antenna Factor + Amplifier Factor + Cable loss
5. QP value = Factor + Reading Value.

Position: Vertical

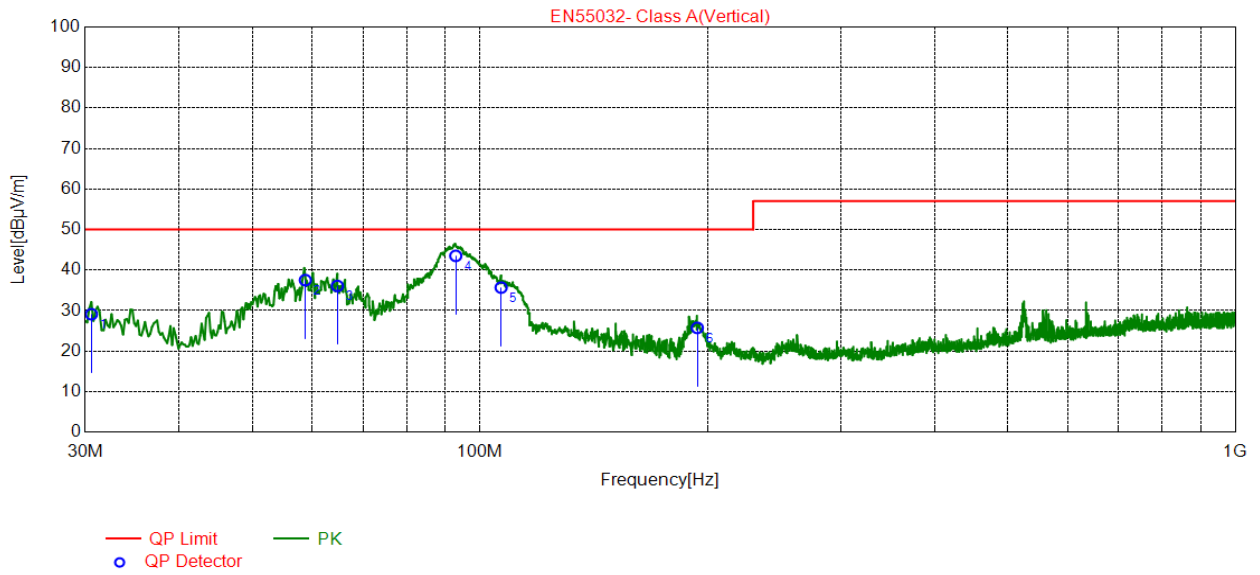

| NO. | Freq. [MHz] | QP Reading [dB µ V/m] | Factor [dB] | QP Value [dB µ V/m] | QP Limit [dB µ V/m] | QP Margin [dB] | Height [cm] | Angle [°] | Polarity |
|-----|-------------|-----------------------|-------------|---------------------|---------------------|----------------|-------------|-----------|----------|
| 1 | 30.582 | 39.74 | -10.64 | 29.10 | 50.00 | 20.90 | 100 | 117 | Vertical |
| 2 | 58.712 | 47.96 | -10.44 | 37.52 | 50.00 | 12.48 | 100 | 26 | Vertical |
| 3 | 64.726 | 47.37 | -11.29 | 36.08 | 50.00 | 13.92 | 100 | 67 | Vertical |
| 4 | 92.856 | 57.72 | -14.21 | 43.51 | 50.00 | 6.49 | 200 | 149 | Vertical |
| 5 | 106.63 | 48.22 | -12.55 | 35.67 | 50.00 | 14.33 | 100 | 256 | Vertical |
| 6 | 193.93 | 37.83 | -12.10 | 25.73 | 50.00 | 24.27 | 100 | 32 | Vertical |

REMARKS:

1. Q.P. is abbreviation of quasi-peak individually.
2. The emission levels of other frequencies were very low against the limit.
3. QP Margin value = QP Limit value – QP value
4. Factor = Antenna Factor + Amplifier Factor + Cable loss
5. QP value = Factor + Reading Value.

6.6. Test Result and Data (1GHz ~ 6GHz)

For AC24V port test on AC adapter

Position: Horizontal

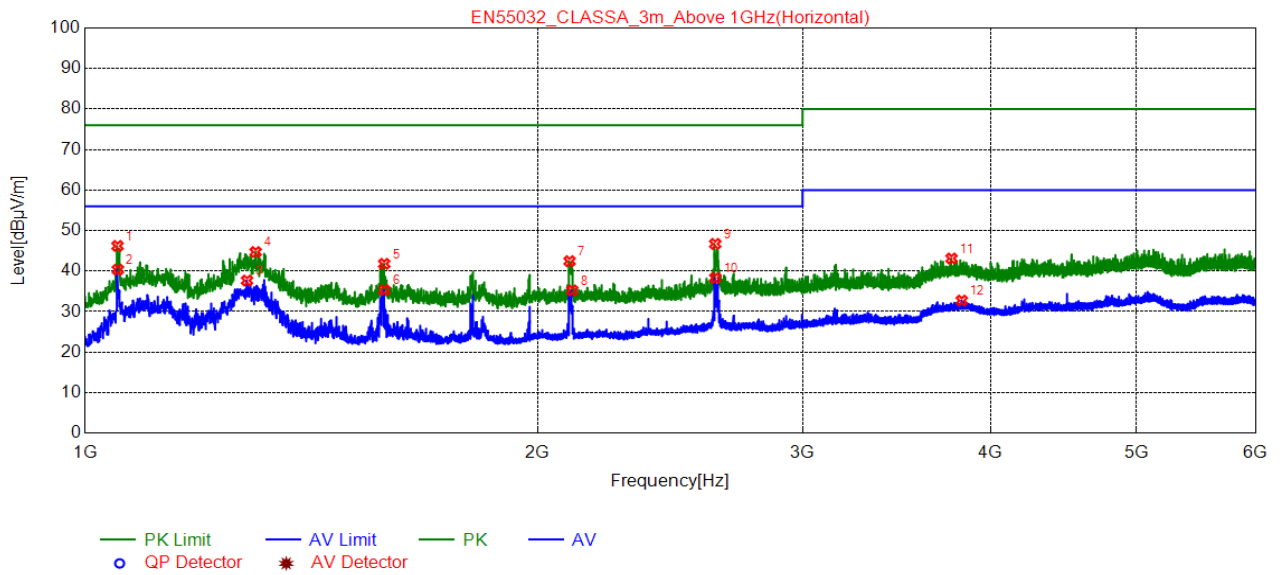

| NO. | Freq. [MHz] | Reading [dBµV/m] | Level [dBµV/m] | Limit [dBµV/m] | Margin [dB] | Height [cm] | Angle [°] | Polarity | Detector |
|-----|----------------|---------------------|-------------------|-------------------|----------------|----------------|--------------|------------|----------|
| 1 | 1051.0000 | 65.52 | 46.20 | 76.00 | 29.80 | 100 | 109 | Horizontal | PK |
| 2 | 1051.5000 | 59.66 | 40.34 | 56.00 | 15.66 | 100 | 109 | Horizontal | AV |
| 3 | 1281.5000 | 56.25 | 37.66 | 56.00 | 18.34 | 100 | 193 | Horizontal | AV |
| 4 | 1298.5000 | 63.23 | 44.70 | 76.00 | 31.30 | 100 | 193 | Horizontal | PK |
| 5 | 1581.0000 | 59.50 | 41.79 | 76.00 | 34.21 | 100 | 130 | Horizontal | PK |
| 6 | 1581.5000 | 53.00 | 35.29 | 56.00 | 20.71 | 100 | 130 | Horizontal | AV |
| 7 | 2100.0000 | 59.02 | 42.44 | 76.00 | 33.56 | 100 | 109 | Horizontal | PK |
| 8 | 2108.5000 | 51.79 | 35.23 | 56.00 | 20.77 | 100 | 151 | Horizontal | AV |
| 9 | 2624.5000 | 62.14 | 46.71 | 76.00 | 29.29 | 100 | 193 | Horizontal | PK |
| 10 | 2625.0000 | 53.73 | 38.30 | 56.00 | 17.70 | 100 | 214 | Horizontal | AV |
| 11 | 3768.5000 | 55.19 | 43.10 | 80.00 | 36.90 | 100 | 235 | Horizontal | PK |
| 12 | 3828.0000 | 44.66 | 32.71 | 60.00 | 27.29 | 100 | 340 | Horizontal | AV |

REMARKS:

1. The emission levels of other frequencies were very low against the limit.
2. Margin = Limit –Level

Position: Vertical

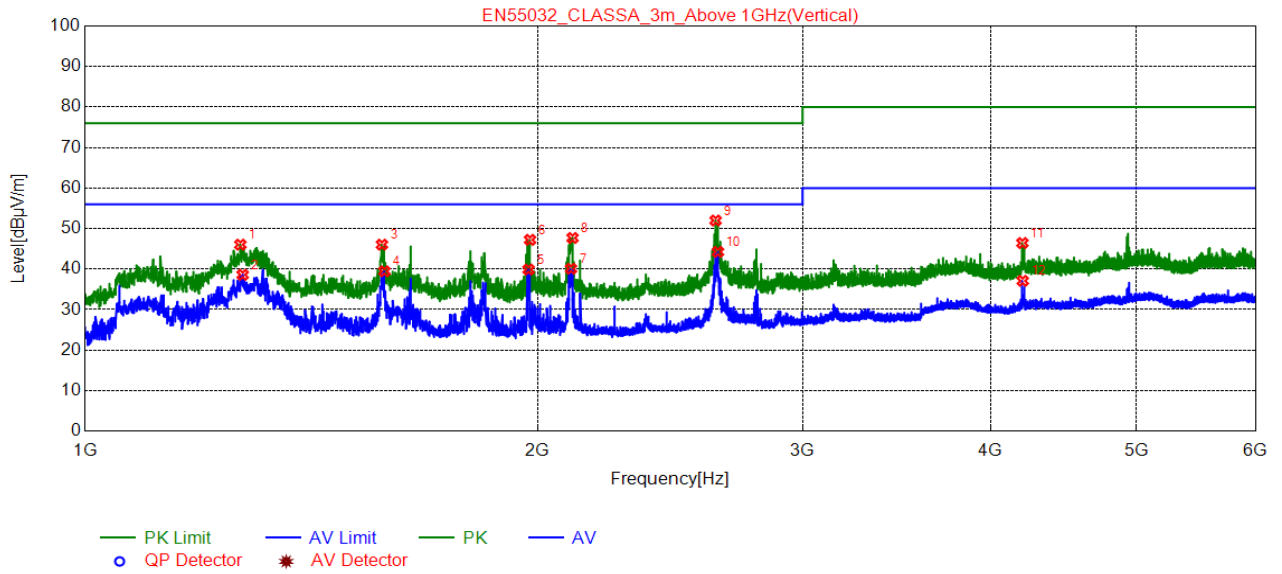

| NO. | Freq. [MHz] | Reading [dBµV/m] | Level [dBµV/m] | Limit [dBµV/m] | Margin [dB] | Height [cm] | Angle [°] | Polarity | Detector |
|-----|----------------|---------------------|-------------------|-------------------|----------------|----------------|--------------|----------|----------|
| 1 | 1268.5000 | 64.65 | 46.03 | 76.00 | 29.97 | 100 | 146 | Vertical | PK |
| 2 | 1273.0000 | 57.19 | 38.58 | 56.00 | 17.42 | 100 | 125 | Vertical | AV |
| 3 | 1575.5000 | 63.75 | 46.03 | 76.00 | 29.97 | 100 | 83 | Vertical | PK |
| 4 | 1581.5000 | 57.16 | 39.45 | 56.00 | 16.55 | 100 | 83 | Vertical | AV |
| 5 | 1972.0000 | 56.73 | 39.88 | 56.00 | 16.12 | 100 | 125 | Vertical | AV |
| 6 | 1976.5000 | 64.06 | 47.22 | 76.00 | 28.78 | 100 | 125 | Vertical | PK |
| 7 | 2104.5000 | 56.65 | 40.08 | 56.00 | 15.92 | 100 | 146 | Vertical | AV |
| 8 | 2109.5000 | 64.24 | 47.68 | 76.00 | 28.32 | 100 | 146 | Vertical | PK |
| 9 | 2626.0000 | 67.41 | 51.99 | 76.00 | 24.01 | 100 | 209 | Vertical | PK |
| 10 | 2635.5000 | 59.64 | 44.24 | 56.00 | 11.76 | 100 | 188 | Vertical | AV |
| 11 | 4200.5000 | 57.54 | 46.43 | 80.00 | 33.57 | 100 | 209 | Vertical | PK |
| 12 | 4202.5000 | 48.19 | 37.09 | 60.00 | 22.91 | 100 | 209 | Vertical | AV |

REMARKS:

1. The emission levels of other frequencies were very low against the limit.
2. Margin = Limit –Level

For POE port test on POE adapter
Position: Horizontal

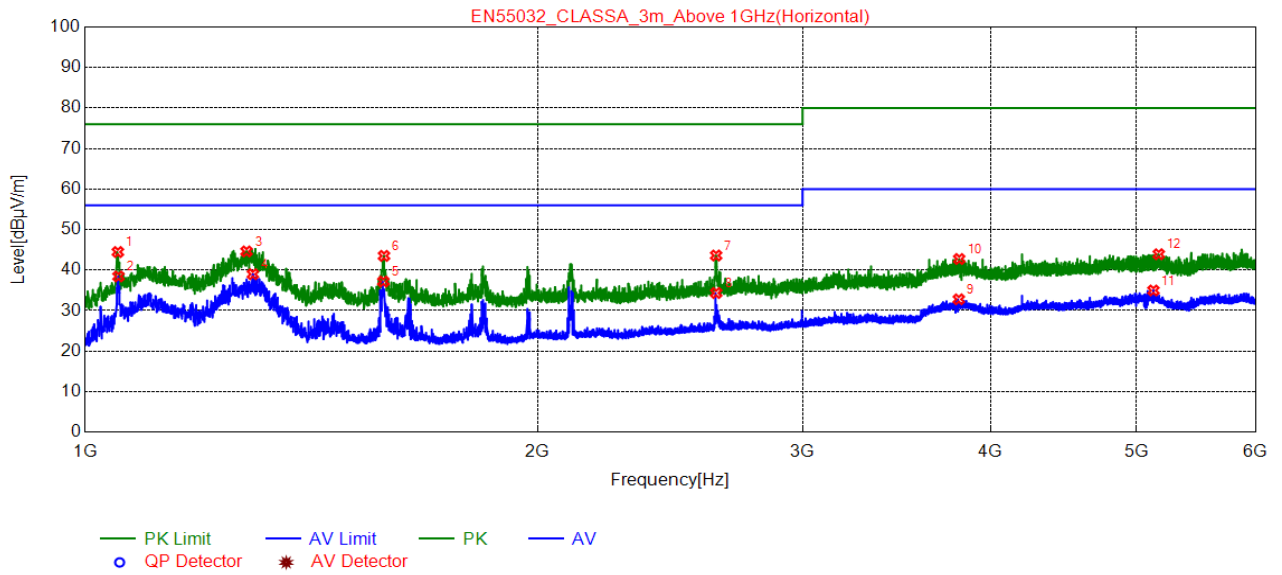

| NO. | Freq. [MHz] | Reading [dBµV/m] | Level [dBµV/m] | Limit [dBµV/m] | Margin [dB] | Height [cm] | Angle [°] | Polarity | Detector |
|-----|-------------|------------------|----------------|----------------|-------------|-------------|-----------|------------|----------|
| 1 | 1051.5000 | 63.78 | 44.46 | 76.00 | 31.54 | 100 | 125 | Horizontal | PK |
| 2 | 1052.5000 | 57.75 | 38.43 | 56.00 | 17.57 | 100 | 125 | Horizontal | AV |
| 3 | 1280.5000 | 63.19 | 44.60 | 76.00 | 31.40 | 100 | 167 | Horizontal | PK |
| 4 | 1293.0000 | 57.53 | 38.98 | 56.00 | 17.02 | 100 | 146 | Horizontal | AV |
| 5 | 1579.0000 | 54.88 | 37.17 | 56.00 | 18.83 | 100 | 146 | Horizontal | AV |
| 6 | 1580.5000 | 61.21 | 43.50 | 76.00 | 32.50 | 100 | 146 | Horizontal | PK |
| 7 | 2628.0000 | 59.02 | 43.60 | 76.00 | 32.40 | 100 | 167 | Horizontal | PK |
| 8 | 2628.5000 | 49.76 | 34.34 | 56.00 | 21.66 | 100 | 146 | Horizontal | AV |
| 9 | 3810.5000 | 44.77 | 32.78 | 60.00 | 27.22 | 100 | 292 | Horizontal | AV |
| 10 | 3813.0000 | 54.72 | 42.73 | 80.00 | 37.27 | 100 | 333 | Horizontal | PK |
| 11 | 5133.5000 | 44.00 | 34.96 | 60.00 | 25.04 | 100 | 20 | Horizontal | AV |
| 12 | 5175.5000 | 52.91 | 43.91 | 80.00 | 36.09 | 100 | 20 | Horizontal | PK |

REMARKS:

1. The emission levels of other frequencies were very low against the limit.
2. Margin = Limit –Level

Position: Vertical

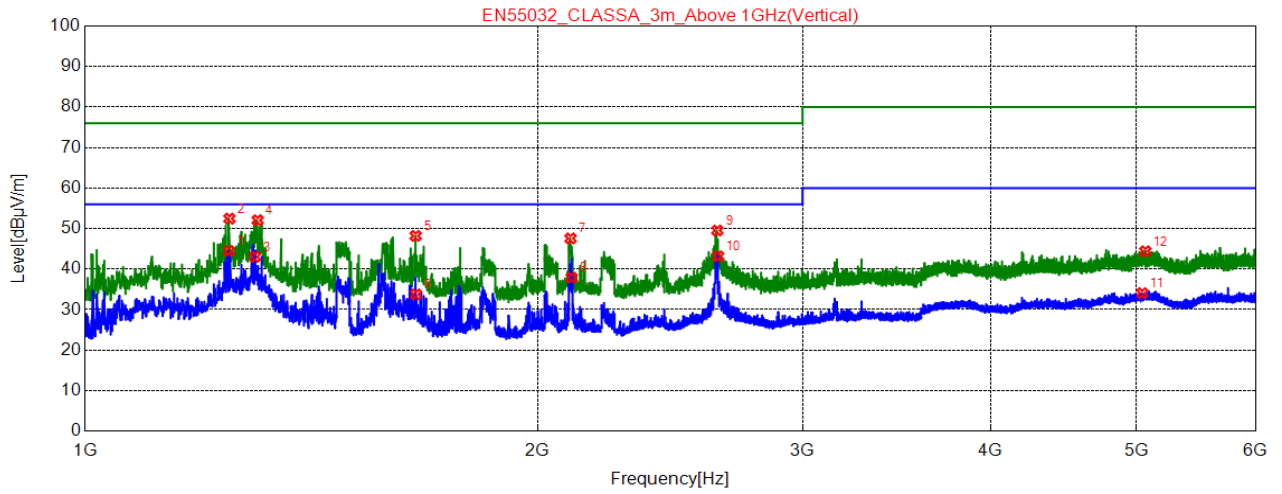

— PK Limit — AV Limit ● PK ● AV
○ QP Detector * AV Detector

| NO. | Freq. [MHz] | Reading [dBµV/m] | Level [dBµV/m] | Limit [dBµV/m] | Margin [dB] | Height [cm] | Angle [°] | Polarity | Detector |
|-----|----------------|---------------------|-------------------|-------------------|----------------|----------------|--------------|----------|----------|
| 1 | 1246.5000 | 63.17 | 44.48 | 56.00 | 11.52 | 100 | 172 | Vertical | AV |
| 2 | 1247.5000 | 71.14 | 52.45 | 76.00 | 23.55 | 100 | 172 | Vertical | PK |
| 3 | 1297.0000 | 61.57 | 43.03 | 56.00 | 12.97 | 100 | 192 | Vertical | AV |
| 4 | 1302.5000 | 70.57 | 52.05 | 76.00 | 23.95 | 100 | 172 | Vertical | PK |
| 5 | 1659.0000 | 65.72 | 48.19 | 76.00 | 27.81 | 100 | 88 | Vertical | PK |
| 6 | 1660.0000 | 51.30 | 33.77 | 56.00 | 22.23 | 100 | 67 | Vertical | AV |
| 7 | 2103.0000 | 64.13 | 47.56 | 76.00 | 28.44 | 100 | 151 | Vertical | PK |
| 8 | 2106.5000 | 54.46 | 37.89 | 56.00 | 18.11 | 100 | 25 | Vertical | AV |
| 9 | 2633.0000 | 64.92 | 49.52 | 76.00 | 26.48 | 100 | 130 | Vertical | PK |
| 10 | 2636.5000 | 58.54 | 43.15 | 56.00 | 12.85 | 100 | 172 | Vertical | AV |
| 11 | 5046.5000 | 43.18 | 34.05 | 60.00 | 25.95 | 100 | 192 | Vertical | AV |
| 12 | 5070.5000 | 53.50 | 44.39 | 80.00 | 35.61 | 100 | 109 | Vertical | PK |

REMARKS:

1. The emission levels of other frequencies were very low against the limit.
2. Margin = Limit –Level

6.7. Test Photographs (30MHz ~ 1000MHz)

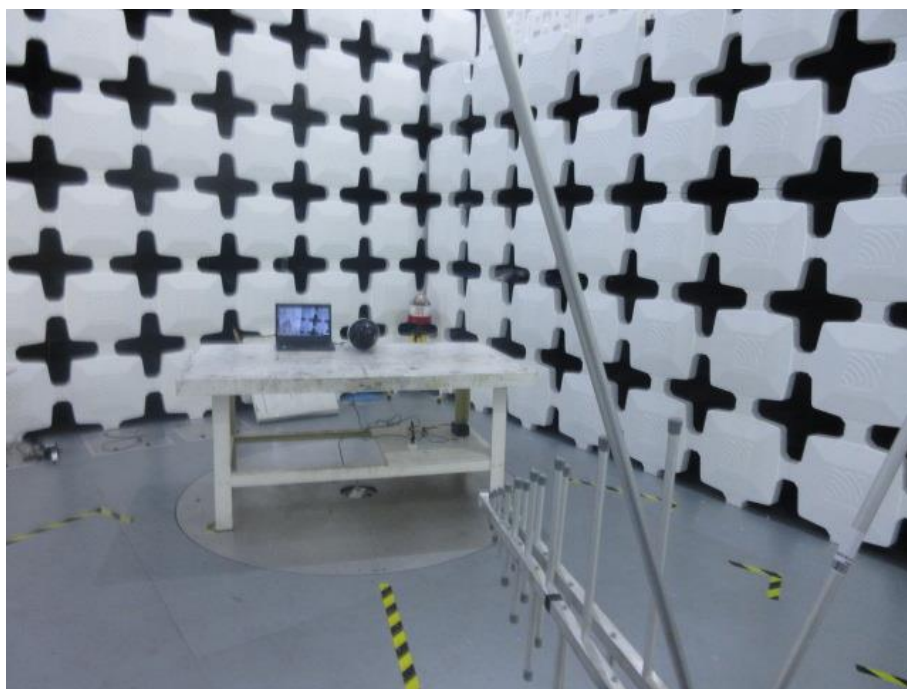
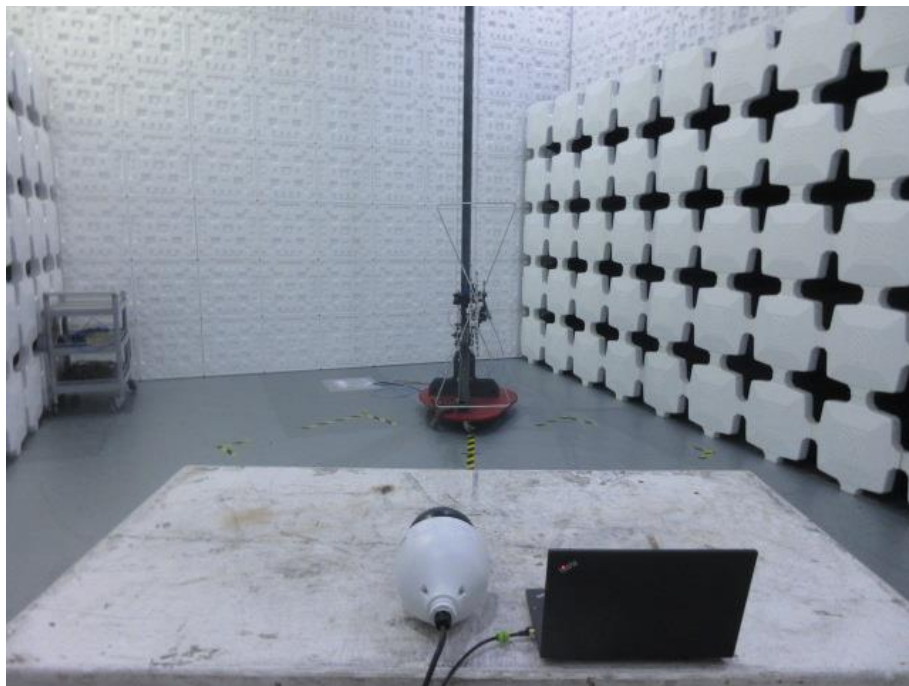

6.8. Test Photographs (1000MHz ~ 6000MHz)

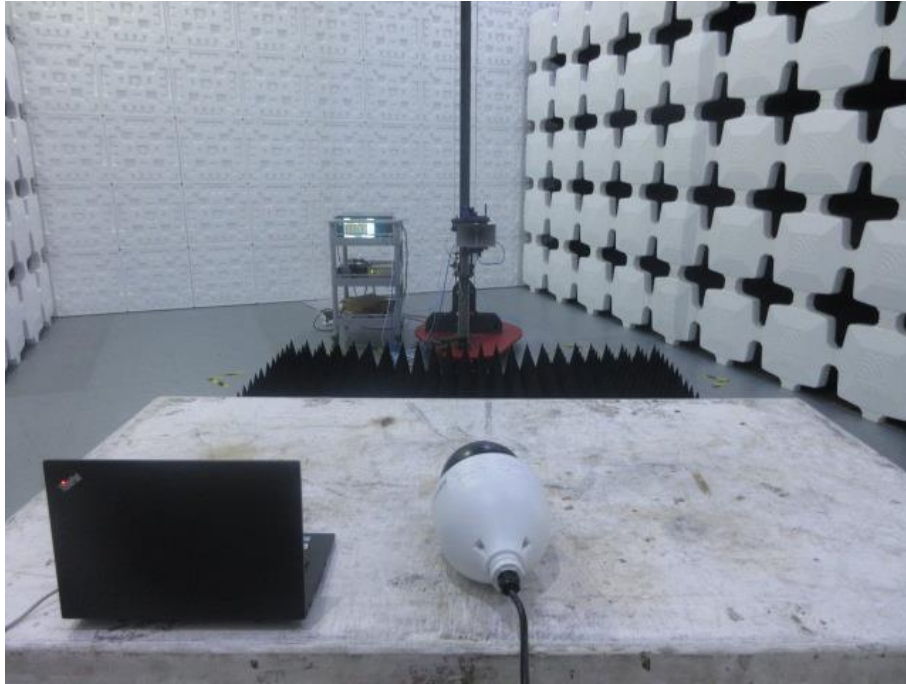

7. Electrostatic Discharge Immunity Test

7.1. Test Procedure

- a. In the case of air discharge testing the climatic conditions shall be within the following ranges:
 - ambient temperature: 15°C to 35°C;
 - relative humidity : 30% to 60%;
 - atmospheric pressure : 86 KPa (860 mbar) to 106 KPa (1060 mbar).
- b. Test programs and software shall be chosen so as to exercise all normal modes of operation of the EUT. The use of special exercising software is encouraged, but permitted only where it can be shown that the EUT is being comprehensively exercised.
- c. The test voltage shall be increased from the minimum to the selected test severity level, in order to determine any threshold of failure. The final severity level should not exceed the product specification value in order to avoid damage to the equipment.
- d. The test shall be performed with both air discharge and contact discharge. On reselected points at least 10 single discharges (in the most sensitive polarity) shall be applied on air discharge. On reselected points at least 25 single discharges (in the most sensitive polarity) shall be applied on contact discharge.
- e. For the time interval between successive single discharges an initial value of one second is recommended. Longer intervals may be necessary to determine whether a system failure has occurred.
- f. In the case of contact discharges, the tip of the discharge electrode shall touch the EUT before the discharge switch is operated.
- g. In the case of painted surface covering a conducting substrate, the following procedure shall be adopted :
 - If the coating is not declared to be an insulating coating by the equipment manufacturer, then the pointed tip of the generator shall penetrate the coating so as to make contact with the conducting substrate.
 - Coating declared as insulating by the manufacturer shall only be submitted to the air discharge.
 - The contact discharge test shall not be applied to such surfaces.
- h. In the case of air discharges, the round discharge tip of the discharge electrode shall be approached as fast as possible (without causing mechanical damage) to touch the EUT . After each discharge, the ESD generator (discharge electrode) shall be removed from the EUT. The generator is then retriggered for a new single discharge. This procedure shall be repeated until the discharges are completed. In the case of an air discharge test, the discharge switch, which is used for contact discharge, shall be closed.

7.2. Test Setup for Tests Performed in Laboratory

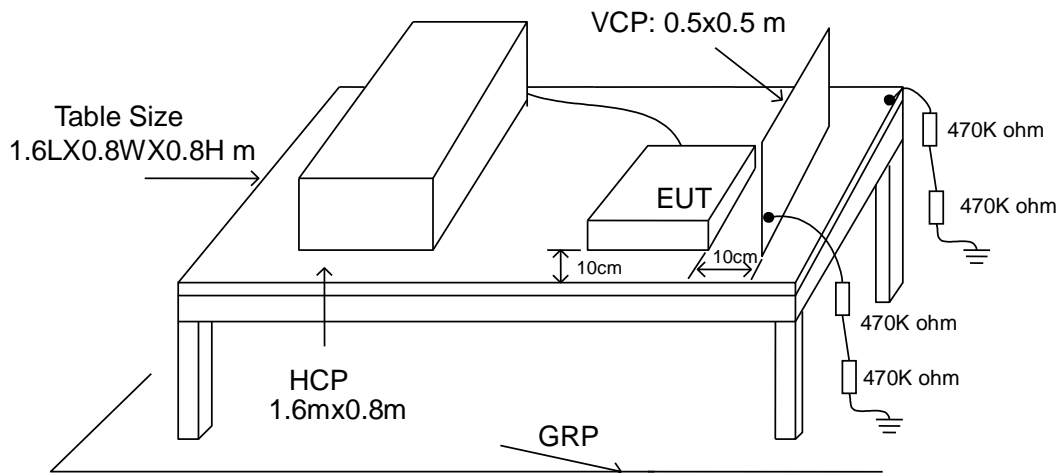

The test setup consists of the test generator, EUT and auxiliary instrumentation necessary to perform DIRECT and INDIRECT application of discharges to the EUT as applicable, in the follow manner :

- a. Contact Discharge to the conductive surfaces and to coupling plane;
- b. Air Discharge at insulating surfaces.

The preferred test method is that of type tests performed in laboratories and the only accepted method of demonstrating conformance with this standard. The EUT was arranged as closely as possible to arrangement in final installed conditions.

A ground reference plane was provided on the floor of the test site. It was a metallic sheet (copper or aluminum) of 0.25 mm, minimum thickness; other metallic may be used but they shall have at least 0.65 mm thickness. In the Cerpas Technology Corp., we provided 1 mm thickness stainless steel ground reference plane. The minimum size of the ground reference plane is 2.5 m x 2.5 m, the exact size depending on the dimensions of the EUT. It was connected to the protective grounding system.

The EUT was arranged and connected according to its functional requirements. A distance of 1m minimum was provided between the EUT and the wall of the lab. and any other metallic structure. In cases where this length exceeds the length necessary to apply the discharges to the selected points, the excess length shall, where possible, be placed non-inductively off the ground reference plane and shall not come closer than 0.2m to other conductive parts in the test setup.

Where the EUT is installed on a metal table, the table was connected to the reference plane via a cable with a 470k ohm resistor located at each end, to prevent a build-up of charge. The test setup was consist a wooden table, 0.8m high, standing on the ground reference plane. A HCP, 1.6 m x 0.8 m, was placed on the table. The EUT and cables was isolated from the HCP by an insulating support 0.5 mm thick. The VCP size, 0.5 m x 0.5 m.

7.3. Test Severity Levels

| Contact Discharge | | Air Discharge | |
|-------------------|----------------------------------------|---------------|------------------------------------|
| Level | Test Voltage (KV) of Contact discharge | Level | Test Voltage (KV) of Air Discharge |
| 1 | ±2 | 1 | ±2 |
| 2 | ±4 | 2 | ±4 |
| 3 | ±6 | 3 | ±8 |
| 4 | ±8 | 4 | ±15 |
| X | Specified | X | Specified |

Remark: "X" is an open level.

7.4. Measurement Equipment

| DESCRIPTION & MANUFACTURER | MODEL NO. | SERIAL NO. | CALIBRATED UNTIL |
|-----------------------------------------------------------|-----------------------|------------|------------------|
| Electrostatic discharge simulator and GUN &Noiseken | ESS-2002EX TC-815R | E1ES016 | Oct.31, 2019 |

7.5. Test Result and Data

| | |
|-------------------------------|-------------------------------------------------------------------------------------------------------|
| Final Test Result | : PASS |
| Pass performance criteria | : A |
| Required performance criteria | : B |
| Basic Standard | : EN 61000-4-2 |
| Product Standard | : EN 50130-4 and EN 55024 |
| Test Voltage | : $\pm 2 / \pm 4 / \pm 8$ KV for air discharge, : $\pm 2 / \pm 4 / \pm 6$ KV for contact discharge |
| Temperature | : 22°C |
| Relative Humidity | : 48 % |
| Atmospheric Pressure | : 101 kPa |

For EN 50130-4

| | Contact Discharge | | | | | | | | Air Discharge | | | | | | | |
|----------------------|-------------------|-----|------|-----|------|-----|------|-----|-----------------|-----|------|-----|------|-----|-------|-----|
| | 10 times / each | | | | | | | | 10 times / each | | | | | | | |
| Voltage | 2 Kv | | 4 Kv | | 6 Kv | | 8 Kv | | 2 Kv | | 4 Kv | | 8 Kv | | 10 Kv | |
| Point\Polarity | + | - | + | - | + | - | + | - | + | - | + | - | + | - | + | - |
| HCP | A | A | A | A | A | A | --- | --- | --- | --- | --- | --- | --- | --- | --- | --- |
| VCP | A | A | A | A | A | A | --- | --- | --- | --- | --- | --- | --- | --- | --- | --- |
| All metal portion | A | A | A | A | A | A | --- | --- | --- | --- | --- | --- | --- | --- | --- | --- |
| All nonmetal portion | --- | --- | --- | --- | --- | --- | --- | --- | A | A | A | A | A | A | --- | --- |

For EN 55024

| | Contact Discharge | | | | | | | | Air Discharge | | | | | | | |
|----------------------|-------------------|-----|------|-----|------|-----|------|-----|-----------------|-----|------|-----|------|-----|-------|-----|
| | 25 times / each | | | | | | | | 10 times / each | | | | | | | |
| Voltage | 2 Kv | | 4 Kv | | 6 Kv | | 8 Kv | | 2 Kv | | 4 Kv | | 8 Kv | | 10 Kv | |
| Point\Polarity | + | - | + | - | + | - | + | - | + | - | + | - | + | - | + | - |
| HCP | A | A | A | A | A | A | --- | --- | --- | --- | --- | --- | --- | --- | --- | --- |
| VCP | A | A | A | A | A | A | --- | --- | --- | --- | --- | --- | --- | --- | --- | --- |
| All metal portion | A | A | A | A | A | A | --- | --- | --- | --- | --- | --- | --- | --- | --- | --- |
| All nonmetal portion | --- | --- | --- | --- | --- | --- | --- | --- | A | A | A | A | A | A | --- | --- |

For EN 55035

| | Contact Discharge | | | | | | | | Air Discharge | | | | | | | |
|----------------------|-------------------|-----|------|-----|------|-----|------|-----|-----------------|-----|------|-----|------|-----|-------|-----|
| | 10 times / each | | | | | | | | 10 times / each | | | | | | | |
| Voltage | 2 Kv | | 4 Kv | | 6 Kv | | 8 Kv | | 2 Kv | | 4 Kv | | 8 Kv | | 10 Kv | |
| Point\Polarity | + | - | + | - | + | - | + | - | + | - | + | - | + | - | + | - |
| HCP | A | A | A | A | A | A | --- | --- | --- | --- | --- | --- | --- | --- | --- | --- |
| VCP | A | A | A | A | A | A | --- | --- | --- | --- | --- | --- | --- | --- | --- | --- |
| All metal portion | A | A | A | A | A | A | --- | --- | --- | --- | --- | --- | --- | --- | --- | --- |
| All nonmetal portion | --- | --- | --- | --- | --- | --- | --- | --- | A | A | A | A | A | A | --- | --- |



8. Radio Frequency electromagnetic field immunity test

8.1. Test Procedure

- a. The equipment to be tested is placed in the center of the enclosure on a wooden table. The equipment is then connected to power and signal leads according to pertinent installation instructions.
- b. The antenna which is enabling the complete frequency range of 80-1000 MHz is placed 3m away from the equipment. The required field strength is determined by placing the field strength meter(s) on top of or directly alongside the equipment under test and monitoring the field strength meter via a remote field strength indicator outside the enclosure while adjusting the continuous-wave to the applicable antennae.
- c. The test is normally performed with the antenna facing the most sensitive side of the EUT. The polarization of the field generated by the bucolical antenna necessitates testing each position twice, once with the antenna positioned vertically and again with the antenna positioned horizontally. The circular polarization of the field from the log-spiral antenna makes a change of position of the antenna unnecessary.
- d. At each of the above conditions, the frequency range is swept 80-1000 MHz, pausing to adjust the R.F. signal level or to switch oscillators and antenna. The rate of sweep is in the order of $1.5 \cdot 10^{-3}$ decades/s. The sensitive frequencies or frequencies of dominant interest may be discretely analyzed.

8.2. Test Severity Levels

| Frequency Band : 80-1000 MHz | |
|-------------------------------|---------------------------|
| Level | Test field strength (V/m) |
| 1 | 1 |
| 2 | 3 |
| 3 | 10 |
| X | Specified |
| Remark: "X" is an open class. | |

8.3. TEST SETUP

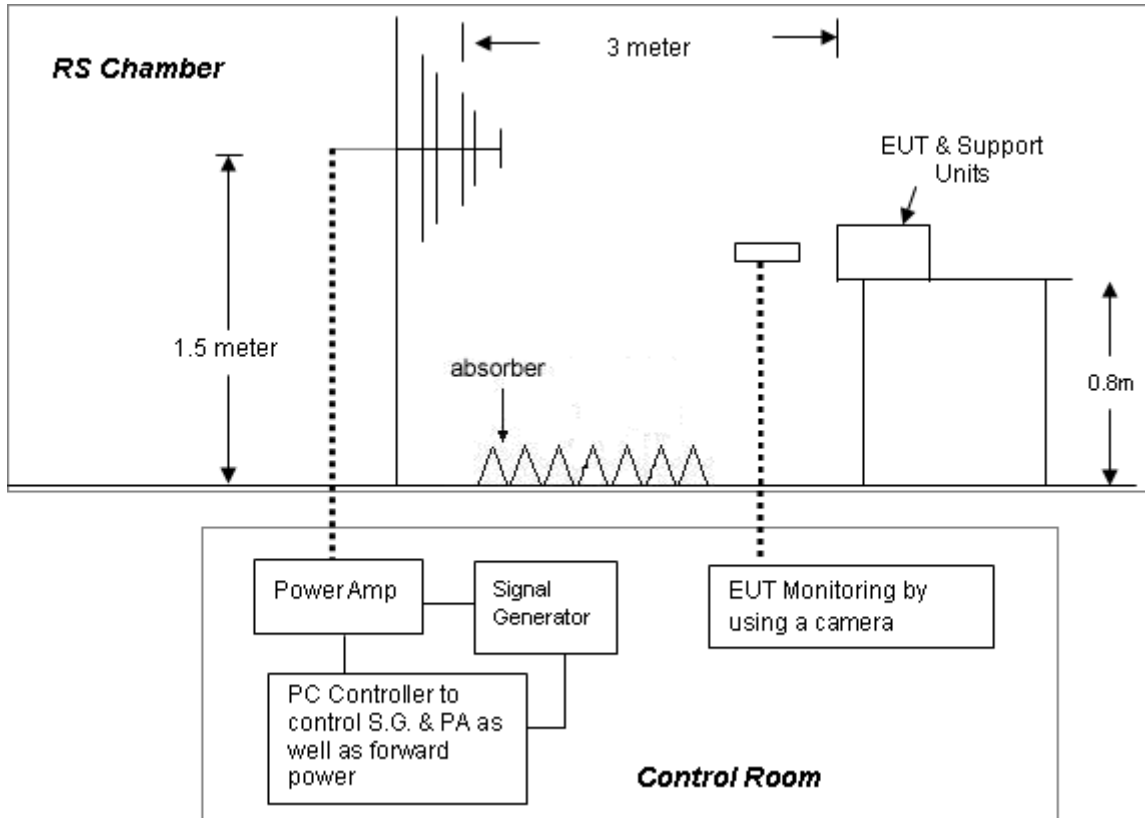

- For the actual test configuration, please refer to the related item – Photographs of the Test Configuration.

NOTE:

TABLETOP EQUIPMENT

The EUT installed in a representative system as described in section 7 of IEC 61000-4-3 was placed on a non-conductive table 0.8 meters in height. The system under test was connected to the power and signal wire according to relevant installation instructions.

FLOOR STANDING EQUIPMENT

The EUT installed in a representative system as described in section 7 of IEC 61000-4-3 was placed on a non-conductive wood support 0.1 meters in height. The system under test was connected to the power and signal wire according to relevant installation instructions.

8.4. Measurement Equipment

| DESCRIPTION & MANUFACTURER | MODEL NO. | SERIAL NO. | CALIBRATED UNTIL |
|---------------------------------------|--------------|------------|------------------|
| Signal Generator ANRITSU | MG3692B | E1S9006 | Mar.04, 2020 |
| BiconiLog Antenna SCHWARZBECK | VULP 9118 E | E1A1037 | Feb.08, 2020 |
| High Gain Horn Antenna SCHWARZBECK | STLP 9149 | E1A1038 | Feb.08, 2020 |
| RF Power Amplifier MILMEGA | 80RF 1000-75 | E1P4004 | Apr.11, 2020 |
| RF Power Amplifier MILMEGA | AS0102-65 | E1P4005 | Apr.11, 2020 |
| RF Power Amplifier MILMEGA | AS1860-50 | E1P4006 | Apr.11, 2020 |
| Power Meter | 4232A/51011 | E1P5001 | Dec.03, 2019 |
| Software | TOYO | N/A | N/A |

8.5. Test Result and Data

Final Test Result : **PASS**
 Pass performance criteria : A
 Required performance criteria : A
 Basic Standard : EN 61000-4-3
 Product Standard : EN 50130-4 and EN 55024
 Frequency Range : 80~2700 MHz
 Temperature : 22°C
 Relative Humidity : 48%
 Atmospheric Pressure : 101 kPa

For EN 50130-4

| 1. Modulation : AM 80% , 1KHz sine wave, Dwell time: 3 S 2. Modulation : PM 1Hz(0.5s ON, 0.5s OFF), Dwell time: 3 S Frequency Step Size : 1 % of preceding frequency value | | | | |
|----------------------------------------------------------------------------------------------------------------------------------------------------------------------------------|----------------------|-------|----------------------|--------|
| Frequency (MHz) | Antenna Polarization | face | Field strength (V/m) | Result |
| 80~2700 | Vertical | Front | 10 V/m | A |
| 80~2700 | Vertical | Rear | 10 V/m | A |
| 80~2700 | Vertical | Left | 10 V/m | A |
| 80~2700 | Vertical | Right | 10 V/m | A |
| 80~2700 | Horizontal | Front | 10 V/m | A |
| 80~2700 | Horizontal | Rear | 10 V/m | A |
| 80~2700 | Horizontal | Left | 10 V/m | A |
| 80~2700 | Horizontal | Right | 10 V/m | A |

For EN 55024

| 1. Modulation : AM 80% , 1KHz sine wave, Dwell time: 3 S Frequency Step Size : 1 % of preceding frequency value | | | | |
|--------------------------------------------------------------------------------------------------------------------|----------------------|-------|----------------------|--------|
| Frequency (MHz) | Antenna Polarization | face | Field strength (V/m) | Result |
| 80~1000 | Vertical | Front | 3 V/m | A |
| 80~1000 | Vertical | Rear | 3 V/m | A |
| 80~1000 | Vertical | Left | 3 V/m | A |
| 80~1000 | Vertical | Right | 3 V/m | A |
| 80~1000 | Horizontal | Front | 3 V/m | A |
| 80~1000 | Horizontal | Rear | 3 V/m | A |
| 80~1000 | Horizontal | Left | 3 V/m | A |
| 80~1000 | Horizontal | Right | 3 V/m | A |

For EN 55035

| 1. Modulation : AM 80% , 1KHz sine wave, Dwell time: 3 S Frequency Step Size : 1 % of preceding frequency value | | | | |
|--------------------------------------------------------------------------------------------------------------------|----------------------|-------|----------------------|--------|
| Frequency (MHz) | Antenna Polarization | face | Field strength (V/m) | Result |
| 80~1000, 1800, 2600, 3500, 5000 | Vertical | Front | 3 V/m | A |
| 80~1000, 1800, 2600, 3500, 5000 | Vertical | Rear | 3 V/m | A |
| 80~1000, 1800, 2600, 3500, 5000 | Vertical | Left | 3 V/m | A |
| 80~1000, 1800, 2600, 3500, 5000 | Vertical | Right | 3 V/m | A |
| 80~1000, 1800, 2600, 3500, 5000 | Horizontal | Front | 3 V/m | A |
| 80~1000, 1800, 2600, 3500, 5000 | Horizontal | Rear | 3 V/m | A |
| 80~1000, 1800, 2600, 3500, 5000 | Horizontal | Left | 3 V/m | A |
| 80~1000, 1800, 2600, 3500, 5000 | Horizontal | Right | 3 V/m | A |

8.6. Test Photographs

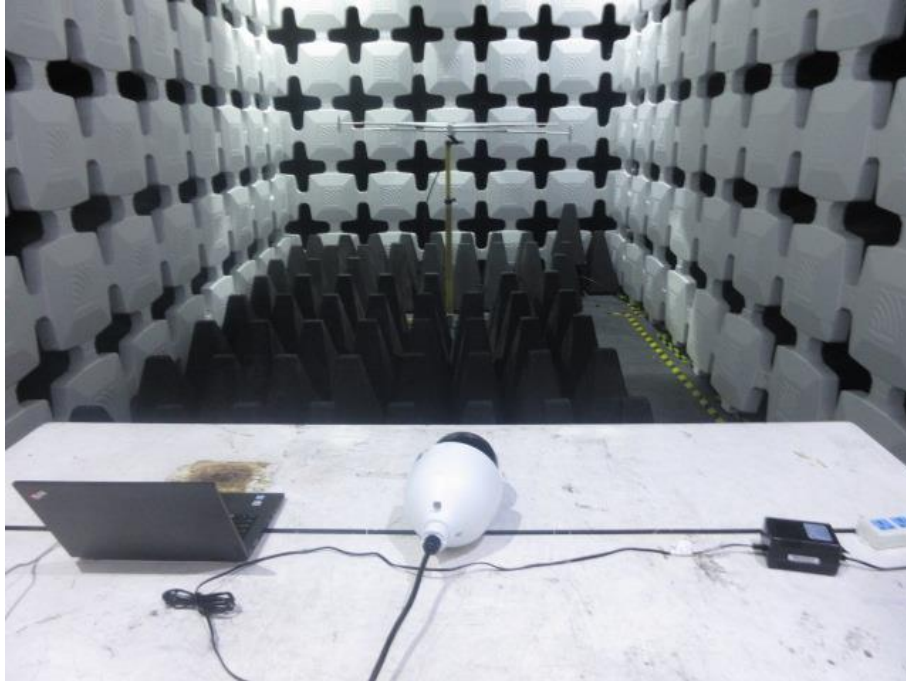

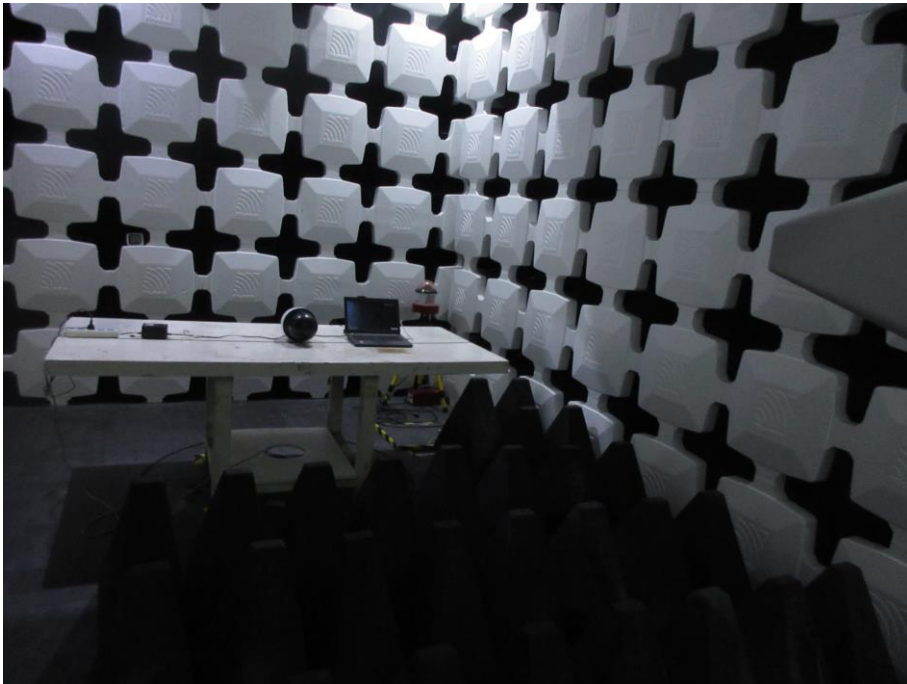
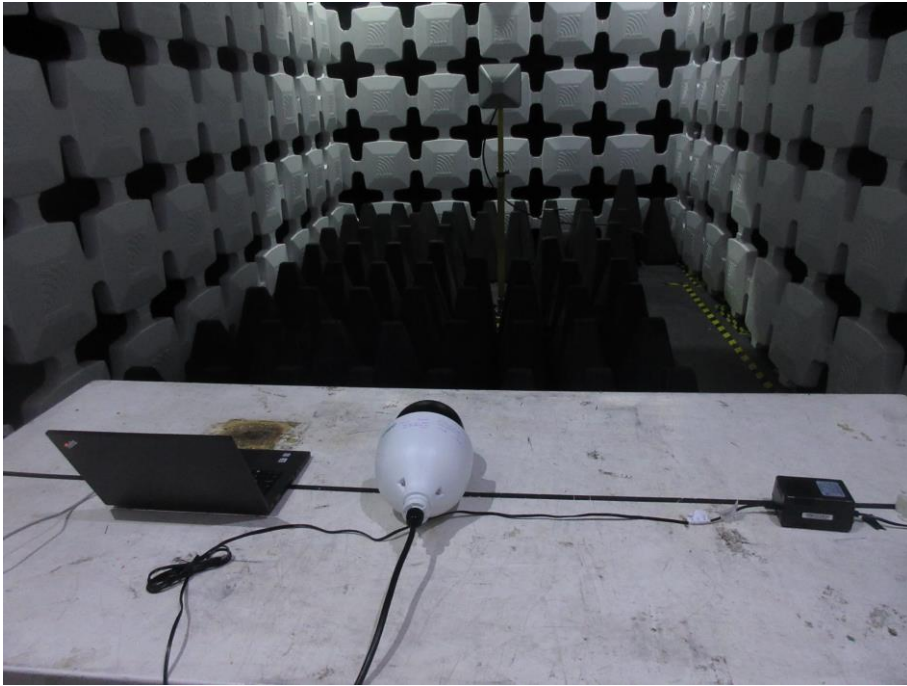

9. Electrical Fast Transient/ Burst Immunity Test

9.1. Test Procedure

- a. In order to minimize the effect of environmental parameters on test results, the climatic conditions when test is carrying out shall comply with the following requirements:
 - ambient temperature: 15°C to 35°C;
 - relative humidity : 45% to 75%;
 - Atmospheric pressure: 86 Kpa (860 mbar) to 106 Kpa (1060 mbar).
- b. In order to minimize the effect of environmental parameters on test results, the electromagnetic environment of the laboratory shall not influence the test results.
- c. The variety and diversity of equipment and systems to be tested make it difficult to establish general criteria for the evaluation of the effects of fast transients/bursts on equipment and systems.
- d. Test on Power Line:
 - The EFT/B-generator was located on the GRP.
For floor standing equipment 1,0 m
For table top equipment 0,5 m
 - The EFT/B-generator provides the ability to apply the test voltage in a non-symmetrical condition to the power supply input terminals of the EUT.
- e. Test on Communication Lines
 - The coupling clamp is composed of a clamp unit for housing the cable (length more than 3 m), and was placed on the GRP.
 - The coupling clamp provides the ability of coupling the fast transient/bursts to the cable under test.
- f. The test results may be classified on the basic of the operating conditions and the functional specification of the equipment under test, according to the following performance criteria :
 - Normal performance within the specification limits.
 - Temporary degradation or loss of function or performance which is self-recoverable.
 - Temporary degradation or loss of function or performance which requires operator intervention or system reset.
 - Degradation or loss of function which is not recoverable due to damage of equipment (components).

9.2. Test Severity Levels

The following test severity levels are recommended for the fast transient/burst test :

| Open circuit output test voltage $\pm 10\%$ | | |
|---------------------------------------------|-----------------|--------------------------------------|
| Level | On Power Supply | On I/O signal, data and control line |
| 1 | 0.5 KV | 0.25 KV |
| 2 | 1.0 KV | 0.50 KV |
| 3 | 2.0 KV | 1.00 KV |
| 4 | 4.0 KV | 2.00 KV |
| X | Specified | Specified |

Remark : “ X ” is an open level. The level is subject to negotiation between the user and manufacturer or is specified by the manufacturer.

9.3. TEST SETUP

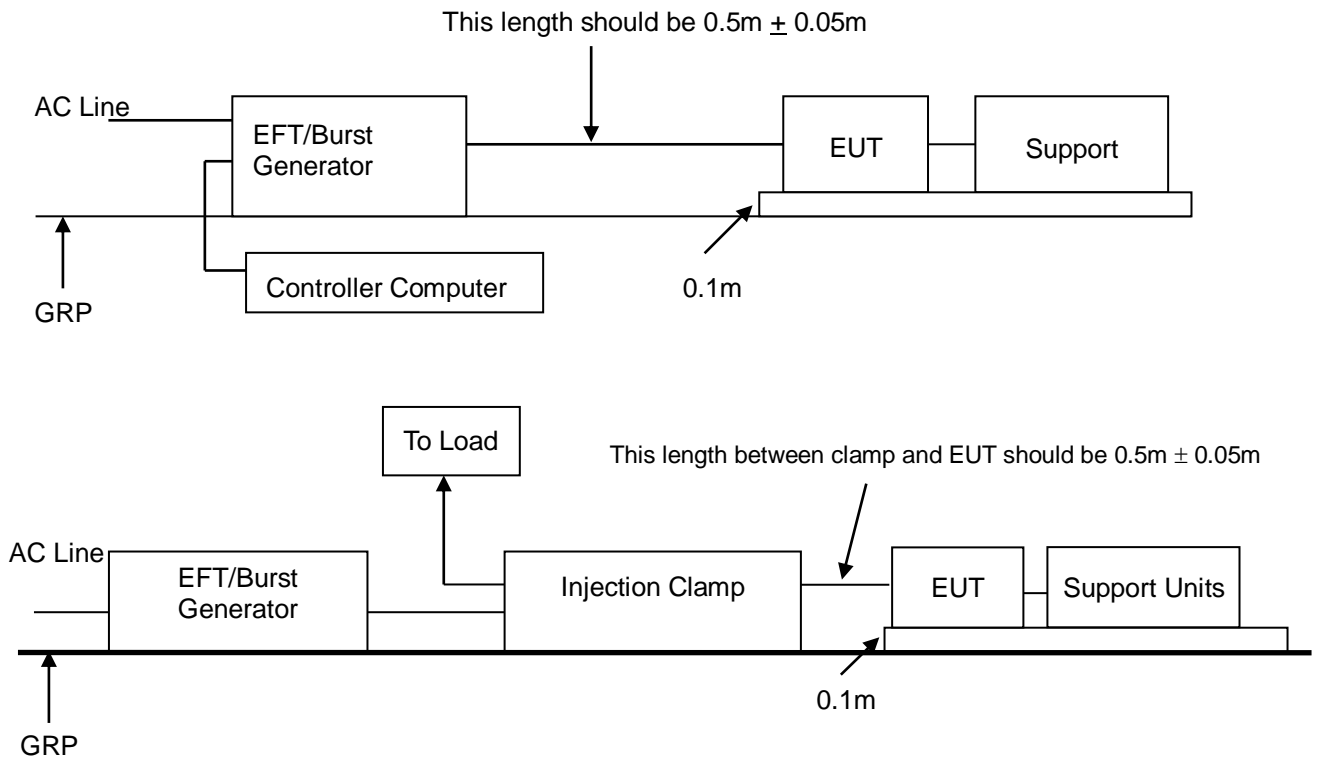

- For the actual test configuration, please refer to the related item – Photographs of the Test Configuration.

NOTE:

TABLETOP EQUIPMENT

The configuration consisted of a wooden table (0.1m high) standing on the Ground Reference Plane. The GRP consisted of a sheet of aluminum (at least 0.25mm thick and 2.5m square) connected to the protective grounding system. A minimum distance of 0.5m was provided between the EUT and the walls of the laboratory or any other metallic structure.

FLOOR STANDING EQUIPMENT

The EUT installed in a representative system as described in section 7 of IEC 61000-4-4 and its cables, were isolated from the Ground Reference Plane by an insulating support that is 0.1-meter thick. The GRP consisted of a sheet of aluminum (at least 0.25mm thick and 2.5m square) connected to the protective grounding system.

9.4. Measurement Equipment

| DESCRIPTION & MANUFACTURER | MODEL NO. | SERIAL NO. | CALIBRATED UNTIL |
|----------------------------|-----------|------------|------------------|
| EMC Test System &Teseq | NSG3060 | E1ES021 | Mar.04, 2020 |
| Capacitor Clamp | SYS014 | E1C3001 | Dec.18, 2019 |

9.5. Test Result and Data

| | |
|-------------------------------|---------------------------------------------------------------------------------------------------------------|
| Final Test Result | : PASS |
| Pass performance criteria | : A |
| Required performance criteria | : B |
| Basic Standard | : EN 61000-4-4 |
| Product Standard | : EN 50130-4 and EN 55024 |
| Test Voltage | : On Power Supply -- ± 0.5 KV, ± 1.0 KV, ± 2.0 KV On Signal Port -- ± 0.5 KV, ± 1.0 KV |
| Temperature | : 22 °C |
| Relative Humidity | : 48% |
| Atmospheric Pressure | : 101 kPa |

For EN 50130-4

| | | | | |
|----------------------------------------|--------------------------------|-----|---------------|-----|
| Pulse : 5/50 ns | Repetition Rate: <u>100kHz</u> | | | |
| Burst : 15ms/300ms | | | | |
| Test time : 1 min/each condition | | | | |
| Voltage/ Mode/ Polarity/ Result/ Phase | <u>1.0 kV</u> | | <u>2.0 kV</u> | |
| | + | - | + | - |
| Power Line | --- | --- | A | A |
| Signal Line | A | A | --- | --- |

For EN 55024

| | | | | |
|----------------------------------------|------------------------------|-----|---------------|-----|
| Pulse : 5/50 ns | Repetition Rate: <u>5kHz</u> | | | |
| Burst : 15ms/300ms | | | | |
| Test time : 1 min/each condition | | | | |
| Voltage/ Mode/ Polarity/ Result/ Phase | <u>0.5 kV</u> | | <u>1.0 kV</u> | |
| | + | - | + | - |
| Power Line | --- | --- | A | A |
| Signal Line | A | A | --- | --- |

For EN 55035

| | | | | |
|----------------------------------------|------------------------------|-----|---------------|-----|
| Pulse : 5/50 ns | Repetition Rate: <u>5kHz</u> | | | |
| Burst : 15ms/300ms | | | | |
| Test time : 1 min/each condition | | | | |
| Voltage/ Mode/ Polarity/ Result/ Phase | <u>0.5 kV</u> | | <u>1.0 kV</u> | |
| | + | - | + | - |
| Power Line | --- | --- | A | A |
| Signal Line | A | A | --- | --- |

9.6. Test Photographs

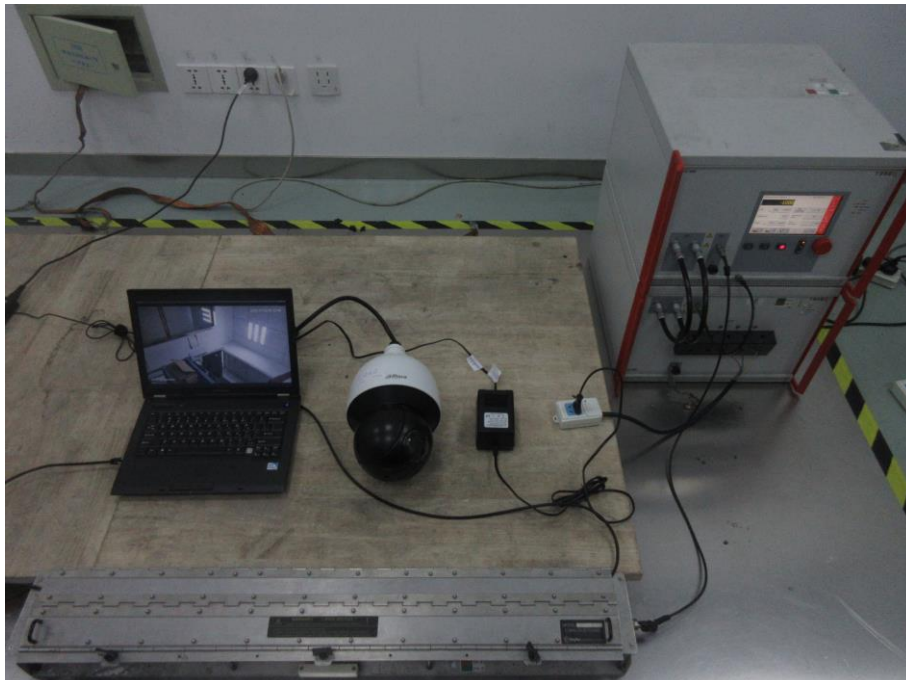

10. Surge Immunity Test

10.1. Test Procedure

- a. Climatic conditions
The climatic conditions shall comply with the following requirements :
 - ambient temperature : 15 °C to 35 °C
 - relative humidity : 10 % to 75 %
 - atmospheric pressure : 86 kPa to 106 kPa (860 mbar to 1060 mbar)
- b. Electromagnetic conditions
the electromagnetic environment of the laboratory shall not influence the test results.
- c. The test shall be performed according the test plan that shall specify the test set-up with
 - generator and other equipment utilized;
 - test level (voltage/current);
 - generator source impedance;
 - internal or external generator trigger;
 - number of tests : at least five positive and five negative at the selected points;
 - repetition rate : maximum 1/min.
 - inputs and outputs to be tested;
 - representative operating conditions of the EUT;
 - sequence of application of the surge to the circuit;
 - phase angle in the case of AC. power supply;
 - actual installation conditions, for example :
 - AC : neutral earthed,
 - DC : (+) or (-) earthed to simulated the actual earthing conditions.
- d. If not otherwise specified the surges have to be applied synchronized to the voltage phase at the zero-crossing and the peak value of the AC. voltage wave (positive and negative).
- e. The surges have to be applied line to line and line(s) and earth. When testing line to earth, the test voltage has to be applied successively between each of the lines and earth, if there is no other specification.
- f. The test procedure shall also consider the non-linear current-voltage characteristics of the equipment under test. Therefore the test voltage has to be increased by steps up to the test level specified in the product standard or test plan.
- g. All lower levels including the selected test level shall be satisfied. For testing the secondary protection, the output voltage of the generator shall be increased up to the worst-case voltage breakdown level (let-through level) of the primary protection.
- h. If the actual operating signal sources are not available, that may be simulated. Under no circumstances may the test level exceed the product specification. The test shall be carried out according to a test plan.
- i. To find all critical points of the duty cycle of the equipment, a sufficient number of positive and negative test pulses shall be applied. For acceptance test previously unstressed equipment shall be used to the protection devices shall be replaced.

10.2. Test Severity Level

| Level | Open-circuit test voltage, $\pm 10\%$, KV |
|---------------------------------------------------------------------------------------|--------------------------------------------|
| 1 | 0.5 |
| 2 | 1.0 |
| 3 | 2.0 |
| 4 | 4.0 |
| X | Specified |
| NOTE: "X" is an open class. This level can be specified in the product specification. | |

10.3. TEST SETUP

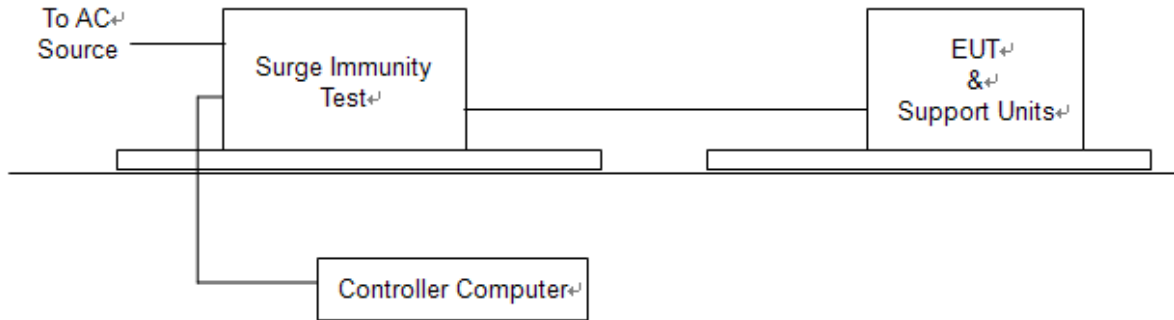

For the actual test configuration, please refer to the related item – Photographs of the Test Configuration.

10.4. Measurement Equipment

| DESCRIPTION & MANUFACTURER | MODEL NO. | SERIAL NO. | CALIBRATED UNTIL |
|----------------------------|-----------|------------|------------------|
| EMC Test System &Teseq | NSG3060 | E1ES021 | Mar.04, 2020 |

10.5. Test Result and Data

| | |
|-------------------------------|-----------------------------------------------------------------------------------------|
| Final Test Result | : PASS |
| Pass performance criteria | : A |
| Required performance criteria | : B |
| Basic Standard | : EN 61000-4-5 |
| Product Standard | : EN 50130-4 and EN 55024 |
| Test Voltage | : Power Port -- ± 0.5 kV, ± 1.0 kV Signal Port -- ± 0.5 kV, ± 1.0 kV |
| Temperature | : 22°C |
| Relative Humidity | : 48% |
| Atmospheric Pressure | : 101 kPa |

For EN 50130-4

| Waveform : 1.2/50 μ s(8/20 μ s) Repetition rate : 60 sec | | | | | | |
|-------------------------------------------------------------------------------------|-------------|---|----|-----|------|------|
| Time : 20 time/each condition for power port, 5 time/each condition for signal port | | | | | | |
| Phase Voltage / Mode / Polarity / Result | | | 0° | 90° | 180° | 270° |
| <u>1.0kV</u> | L-N | + | A | A | A | A |
| | | - | A | A | A | A |
| <u>1.0kV</u> | Signal port | + | A | | | |
| | | - | | | | |

For EN 55024

| Waveform : 1.2/50 μ s(8/20 μ s) Repetition rate : 60 sec | | | | | | |
|-------------------------------------------------------------------------------------|-------------|---|----|-----|------|------|
| Time : 20 time/each condition for power port, 5 time/each condition for signal port | | | | | | |
| Phase Voltage / Mode / Polarity / Result | | | 0° | 90° | 180° | 270° |
| <u>1.0kV</u> | L-N | + | A | A | A | A |
| | | - | A | A | A | A |
| <u>1.0kV</u> | Signal port | + | A | | | |
| | | - | | | | |

For EN 55035

| Waveform : 1.2/50 μ s(8/20 μ s) Repetition rate : 60 sec | | | | | | |
|-------------------------------------------------------------------------------------|-----|---|----|-----|------|------|
| Time : 20 time/each condition for power port, 5 time/each condition for signal port | | | | | | |
| Phase Voltage / Mode / Polarity / Result | | | 0° | 90° | 180° | 270° |
| <u>1.0kV</u> | L-N | + | A | A | A | A |



**BUREAU
VERITAS**

| | | | | | | |
|--------------|-------------|---|---|---|---|---|
| | | - | A | A | A | A |
| <u>1.0kV</u> | Signal port | + | A | | | |
| | | - | | | | |

10.6. Test Photographs



11. Conduction Disturbances induced by Radio-Frequency Fields

11.1. Test Procedure

- a. The EUT shall be operated within its intended climatic conditions. The temperature and relative humidity should be recorded.
- b. This test method test can be performed without using a sell shielded enclosure. This is because the disturbance levels applied and the geometry of the setups are not likely to radiated a high amount of energy, especially at the lower frequencies. If under certain circumstances the radiated energy is too high, a shielded enclosure has to be used.
- c. The test shall be performed with the test generator connected to each of the coupling and decoupling devices in turn while the other non-excited RF-input ports of the coupling devices are terminated by a 50 ohm load resistor.
- d. The frequency range is swept from 150 KHz to 80 MHz, using the signal levels established during the setting process, and with the disturbance signal 80% amplitude modulated with a 1KHz sign wave, pausing to adjust the RF-signal level or to switch coupling devices as necessary. The rate of sweep shall no exceed 1.5×10^{-3} decades/s. Where the frequency is swept incrementally, the step size shall no exceed 1% of the start and thereafter 1% of the preceding frequency value.
- e. The dwell time at each frequency shall not be less than the time necessary for the EUT to be exercised, and able to respond. Sensitive frequencies e.g. clock frequency (ies) and harmonics or frequencies of dominant interest shall be analyzed separately.
- f. An alternative test procedure may be adopted, wherein the frequency range is swept incrementally, with a step size not exceeding 4% of the start ad thereafter 4% of the preceding frequency value. The test level should be at least twice the value of the specified test level.
- g. In cases of dispute, the test procedure using a step size not exceeding 1% of the start and thereafter 1% of preceding frequency value shall take precedence.
- h. Attempts should be made to fully exercise the EUT during testing, and to fully interrogate all exercise modes selected for susceptibility.
- i. The use of special exercising programs is recommended.
- j. Testing shall be performed according to a Test Plan, which shall be included in the test report.
- k. It may be necessary to carry out some investigatory testing in order to establish some aspects of the test plan.

11.2. Test Severity Levels

| Level | Voltage Level (e.m.f.) |
|--------------------------------------------------------------------------------------|--------------------------|
| 1 | 1 V |
| 2 | 3 V |
| 3 | 10 V |
| x | Specified |
| NOTE - x is an open class. This level can be specified in the product specification. | |

11.3. TEST SETUP

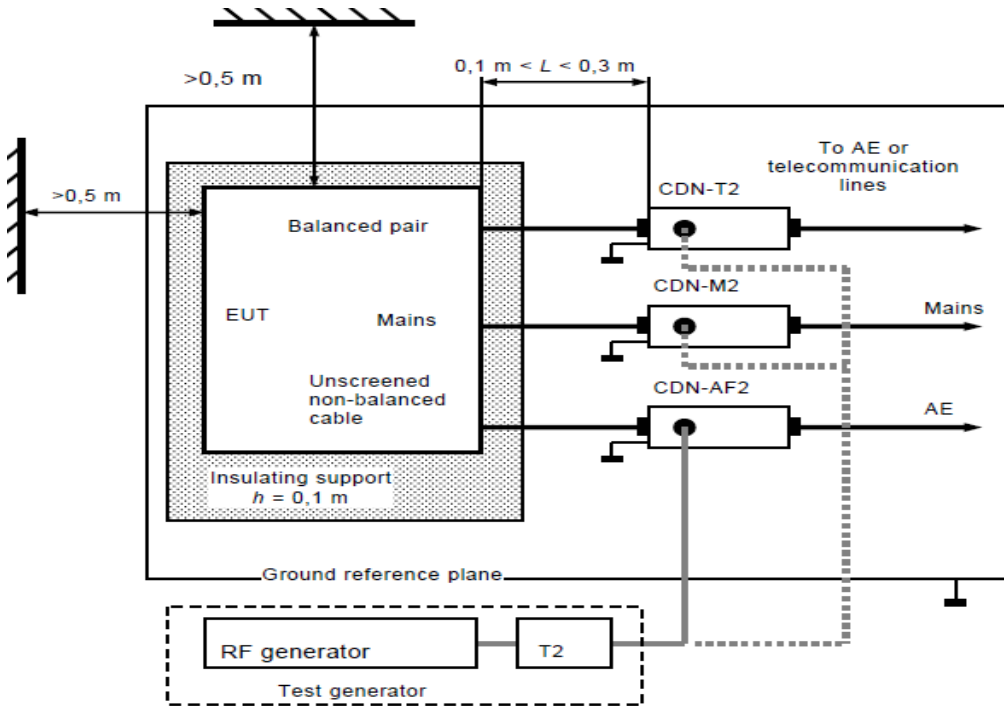

- Note:**
1. The EUT is setup 0.1m above Ground Reference Plane
 2. The CDNs and / or EM clamp used for real test depends on ports and cables configuration of EUT.
 3. For the actual test configuration, please refer to the related item – Photographs of the Test Configuration.

11.4. Measurement Equipment

| DESCRIPTION & MANUFACTURER | MODEL NO. | SERIAL NO. | CALIBRATED UNTIL |
|-------------------------------------------------------------|--------------------|------------|------------------|
| Compact RF Simulator Teseq | NSG 4070-30 | E1ES017 | Jun.04, 2019 |
| Coupling-Decoupling Network Lüthi Elektronik-Feinmechnik | CDN L-801 M2/M3 | E1C4003 | Jul.18, 2019 |
| Electromagnetic Injection Clamp Teseq | EM101 | E1C3003 | Jan.27, 2020 |

11.5. Test Result and Data

| | |
|-------------------------------|------------------------------------------------------------|
| Final Test Result | : PASS |
| Pass performance criteria | : A |
| Required performance criteria | : A |
| Basic Standard | : EN 61000-4-6 |
| Product Standard | : EN 50130-4 and EN 55024 |
| Coupling mode | : CDN-(M2/M3) for power ports EM-CLAMP for Signal Ports |
| Temperature | : 22 °C |
| Relative Humidity | : 48% |
| Atmospheric Pressure | : 101 kPa |

For EN 50130-4

| Frequency : 0.15~100MHz, Modulation : AM 80%,1KHz sine wave and PM 1Hz (0.5s ON, 0.5s OFF) Dwell time:3.0s Frequency Step Size : 1 % of preceding frequency value | | | |
|-------------------------------------------------------------------------------------------------------------------------------------------------------------------------|-------------|------------|--------|
| Frequency | Test mode | Voltage(V) | Result |
| 0.15 ~ 100MHz | Power port | 10 | A |
| 0.15 ~ 100MHz | Signal port | 10 | A |

For EN 55024

| Frequency : 0.15~80MHz, Modulation : AM 80%,1KHz sine wave, Dwell time:3.0s Frequency Step Size : 1 % of preceding frequency value | | | |
|------------------------------------------------------------------------------------------------------------------------------------------|-------------|------------|--------|
| Frequency | Test mode | Voltage(V) | Result |
| 0.15 ~ 80MHz | Power port | 3 | A |
| 0.15 ~ 80MHz | Signal port | 3 | A |

For EN 55035

| Frequency : 0.15~80MHz, Modulation : AM 80%,1KHz sine wave Dwell time:3.0s | | | |
|----------------------------------------------------------------------------|----------------------------|------------|--------|
| Frequency Step Size : 1 % of preceding frequency value | | | |
| Frequency | Test mode | Voltage(V) | Result |
| 0.15 ~ 10MHz | Power port and signal port | 3 | A |
| 10 ~ 30MHz | Power port and signal port | 3 ~ 1 | A |
| 30 ~ 80MHz | Power port and signal port | 1 | A |

11.6. Test Photographs



12. Power Frequency Magnetic Field Immunity Test

12.1. Test Setup

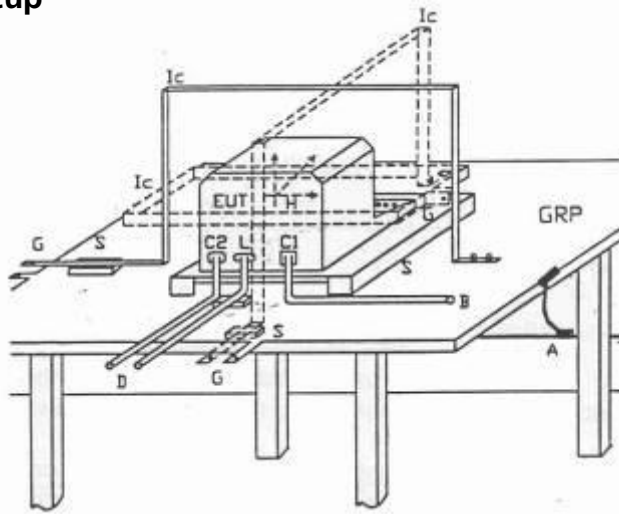

| | | | |
|-----|------------------------|----|-------------------------------|
| GPR | : Ground plane | C1 | : Power supply circuit |
| A | : Safety earth | C2 | : Signal circuit |
| S | : Insulating support | L | : Communication line |
| EUT | : Equipment under test | B | : To power supply source |
| Lc | : Induction coil | D | : To signal source, simulator |
| E | : Earth terminal | G | : To the test generator |

12.2. Test Severity Levels

| Level | Magnetic field strength (A/m) |
|-----------------|-------------------------------|
| 1 | 1 |
| 2 | 3 |
| 3 | 10 |
| 4 | 30 |
| 5 | 100 |
| X ¹⁾ | special |

NOTE 1 "X" is an open level. This level can be given in the product specification.



12.3.Measurement Equipment

| DESCRIPTION & MANUFACTURER | MODEL NO. | SERIAL NO. | CALIBRATED UNTIL |
|------------------------------------------------------------|--------------------------|------------|------------------|
| Signal Conditioning Unit- Lumped Impedance Schaffner | CCN 100-1 | E1HF002 | Aug.27, 2019 |
| 5KV AC Power Source Schaffner | NSG 1007 | E1HF001 | Aug.27, 2019 |
| Field coil | INA 703 coil | E1M 6002 | N/A |
| Software | Shchaffner Win 2100V3 | N/A | N/A |

12.4. Test Result and Data

Final Test Result : **PASS**
 Pass performance criteria : A
 Required performance criteria : A
 Basic Standard : EN 61000-4-8
 Product Standard : EN 55024
 Temperature : 22°C
 Relative Humidity : 48%
 Atmospheric Pressure : 101 kPa

For EN 55024

| Power Frequency Magnetic Field : <u>50/60</u> Hz, <u>1</u> A/m | | |
|----------------------------------------------------------------|------------------|---------|
| Coil Orientation | Testing duration | Results |
| X-axis | 1.0 Min | A |
| Y-axis | 1.0 Min | A |
| Z-axis | 1.0 Min | A |

For EN 55035

| Power Frequency Magnetic Field : <u>50/60</u> Hz, <u>1</u> A/m | | |
|----------------------------------------------------------------|------------------|---------|
| Coil Orientation | Testing duration | Results |
| X-axis | 1.0 Min | A |
| Y-axis | 1.0 Min | A |
| Z-axis | 1.0 Min | A |

12.5. Test Photographs

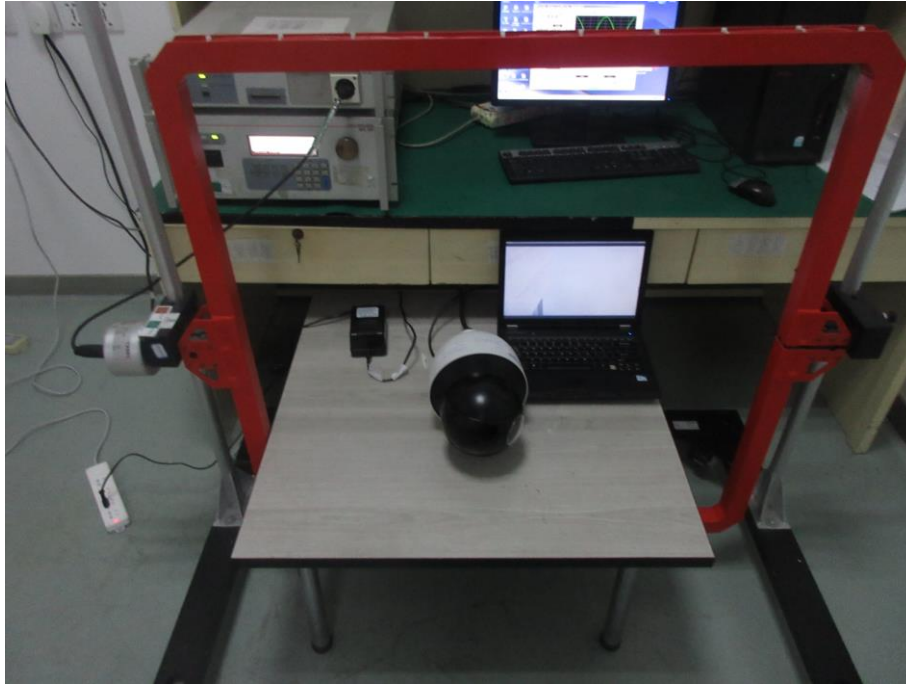

13. Voltage Dips and Voltage Interruptions Immunity Test Setup

13.1. Test Conditions

1. Source voltage and frequency : AC 100/230/240V / 50Hz, Single phase.
2. Test of interval : 10 sec.
3. Level and duration : Sequence of 3 dips/interrupts.
4. Voltage rise (and fall) time : 1 ~ 5 μ s.
5. Test severity :

| Voltage dips and Interrupt reduction (%) | Test Duration (period) |
|------------------------------------------|------------------------|
| >95% | 250 |
| 30% | 25 |
| >95% | 0.5 |

13.2. TEST SETUP

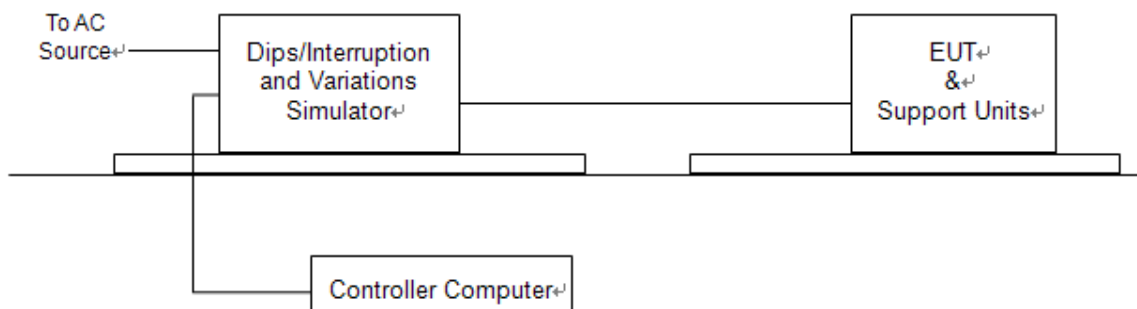

For the actual test configuration, please refer to the related item – Photographs of the Test Configuration.

13.3. Measurement Equipment

| DESCRIPTION & MANUFACTURER | MODEL NO. | SERIAL NO. | CALIBRATED UNTIL |
|----------------------------|-----------|------------|------------------|
| Power Fail Simulator | PFS 503N | E1HF003 | Mar.04, 2020 |
| Power Source | NetWave | S1S1022 | Mar.04, 2020 |

13.4. Test Result and Data

Final Test Result : **PASS**
 Pass performance Criteria : C for voltage interruption, A for voltage dips,
 Required performance Criteria : C for voltage interruption, B/C for voltage dips
 Basic Standard : EN 61000-4-11
 Product Standard : EN 50130-4 and EN 55024
 Temperature : 22°C
 Relative Humidity : 48%
 Atmospheric Pressure : 101 kPa

For EN 50130-4

| Voltage(UT): AC 230 V 50 Hz Interval(s) : 10s Times : 3 | | | | | | | | | | |
|---------------------------------------------------------|--------------------|-----------------------------|----------------|----|----|-----|-----|-----|-----|-----|
| Test mod | Test level UT % | Durations (period / ms) | Phase / Result | | | | | | | |
| | | | 0 | 45 | 90 | 135 | 180 | 225 | 270 | 315 |
| Voltage interruptions | 100% | 250 | C | C | C | C | C | C | C | C |
| Voltage dips | 20% | 250 | A | A | A | A | A | A | A | A |
| | 30% | 25 | A | A | A | A | A | A | A | A |
| | 60% | 10 | A | A | A | A | A | A | A | A |

| Test mod | Test level | Result |
|--------------------|------------|--------|
| Voltage variations | Unom+10% | A |
| | Unom-15% | A |

For EN 55024

| Voltage(UT): AC 230 V 50 Hz Interval(s) : 10s Times : 3 | | | | | | | | | | |
|---------------------------------------------------------|--------------------|-----------------------------|----------------|----|----|-----|-----|-----|-----|-----|
| Test mod | Test level UT % | Durations (period / ms) | Phase / Result | | | | | | | |
| | | | 0 | 45 | 90 | 135 | 180 | 225 | 270 | 315 |
| Voltage interruptions | >95% | 250 | C | C | C | C | C | C | C | C |
| Voltage dips | 30% | 25 | A | A | A | A | A | A | A | A |
| | >95% | 0.5 | A | A | A | A | A | A | A | A |

For EN 55035

| Voltage(UT): AC 230 V 50 Hz Interval(s) : 10s Times : 3 | | | | | | | | | | |
|---------------------------------------------------------------|--------------------|-----------------------------|----------------|----|----|-----|-----|-----|-----|-----|
| Test mod | Test level UT % | Durations (period / ms) | Phase / Result | | | | | | | |
| | | | 0 | 45 | 90 | 135 | 180 | 225 | 270 | 315 |
| Voltage interruptions | >95% | 250 | C | C | C | C | C | C | C | C |
| Voltage dips | 30% | 25 | A | A | A | A | A | A | A | A |
| | >95% | 0.5 | A | A | A | A | A | A | A | A |

13.5. Test Photographs



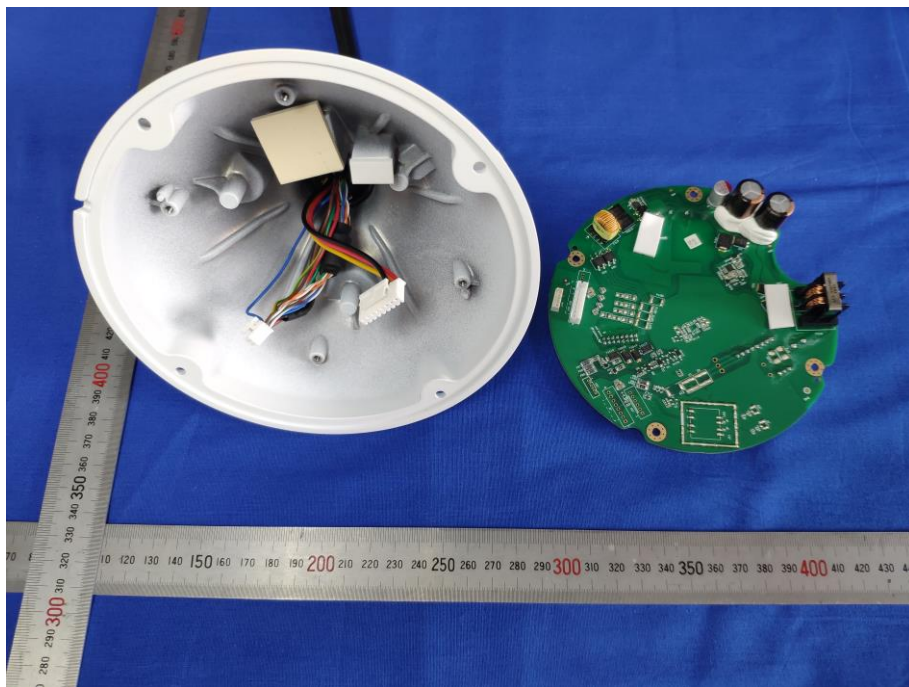



**BUREAU
VERITAS**

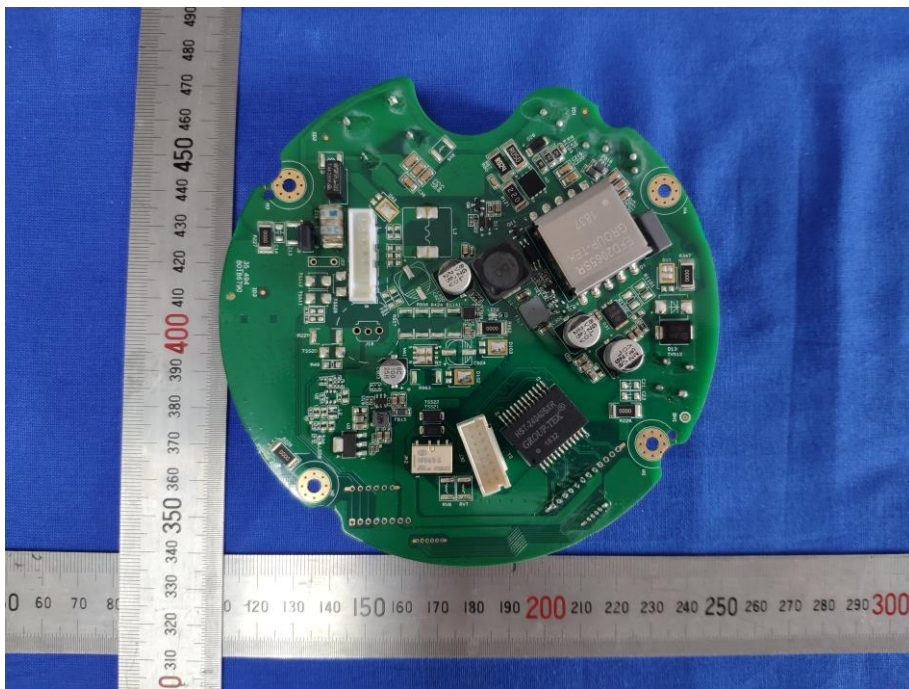
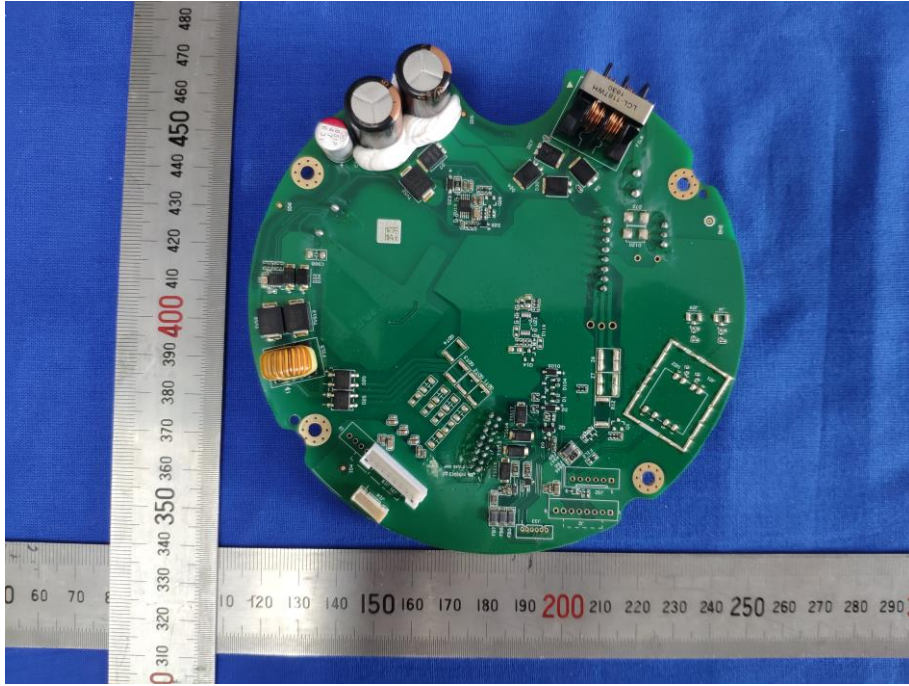



**BUREAU
VERITAS**





**BUREAU
VERITAS**

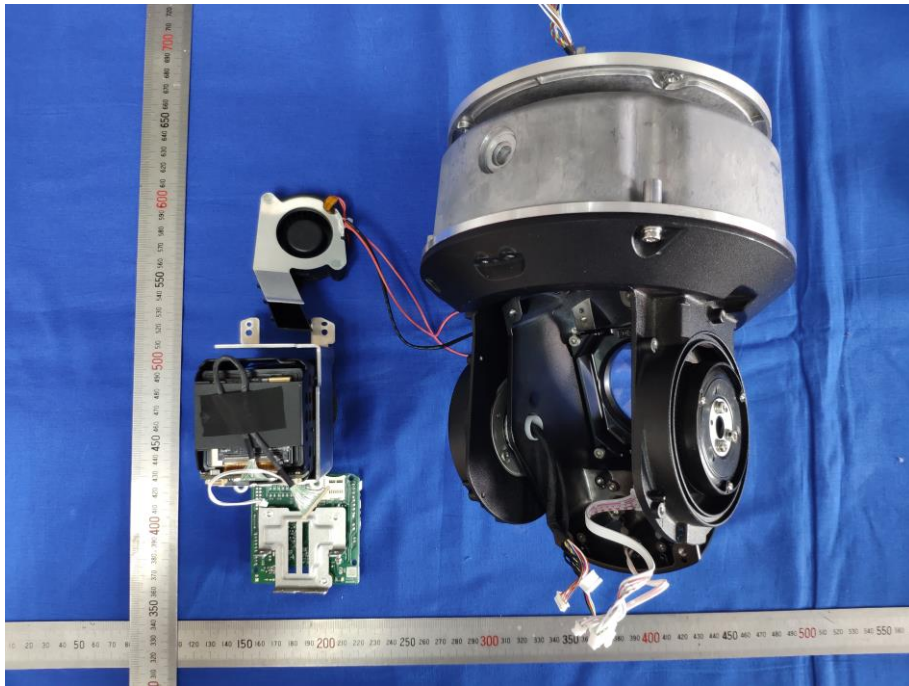
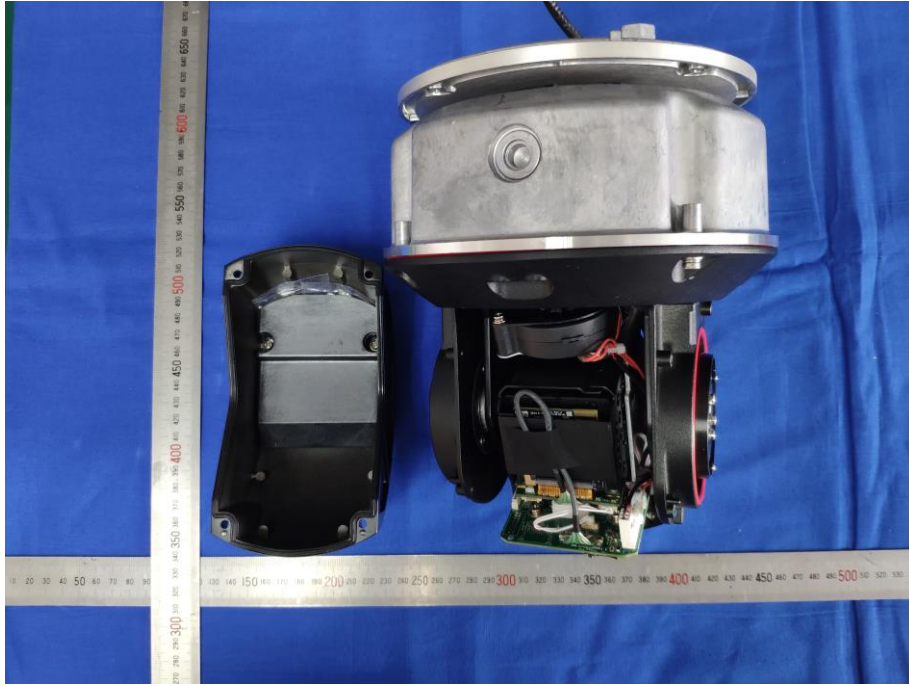



**BUREAU
VERITAS**

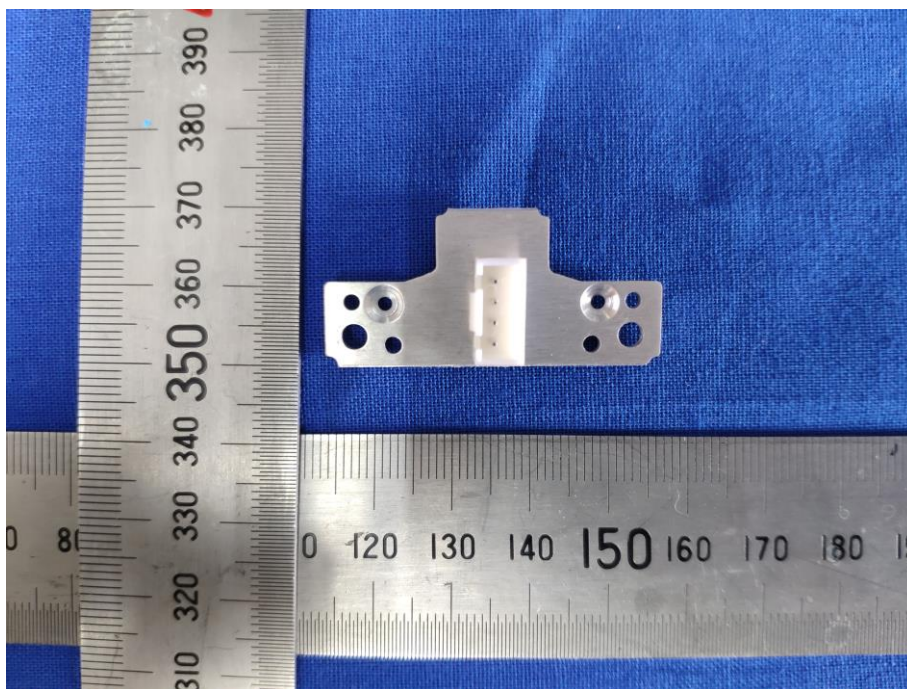
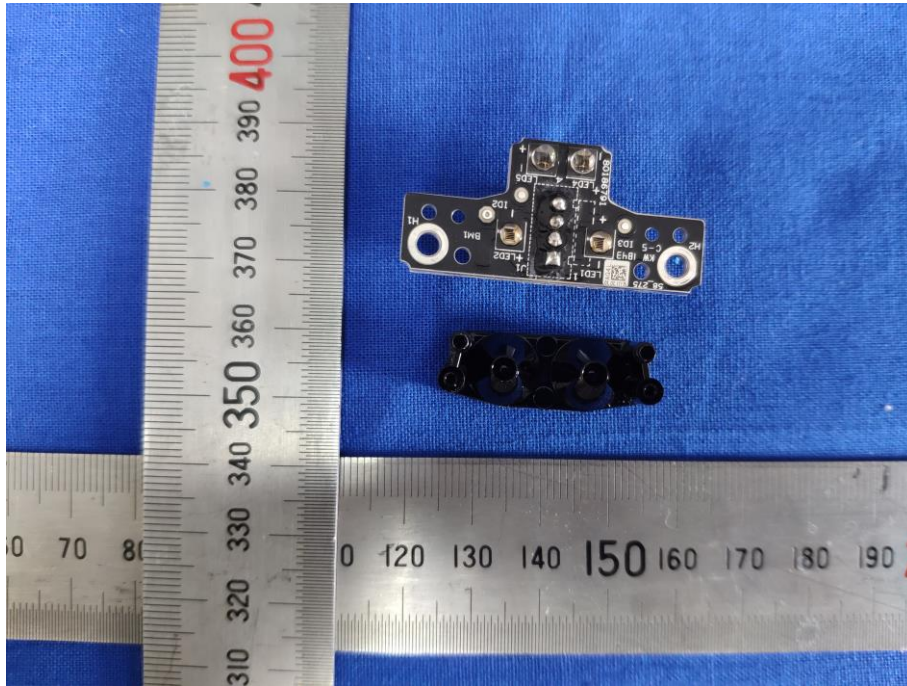



**BUREAU
VERITAS**

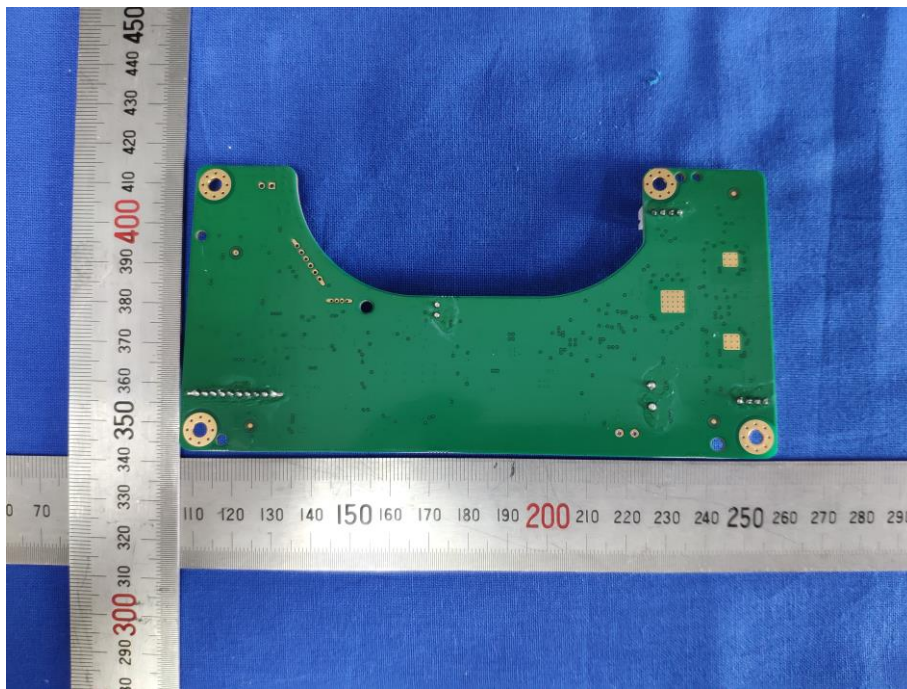
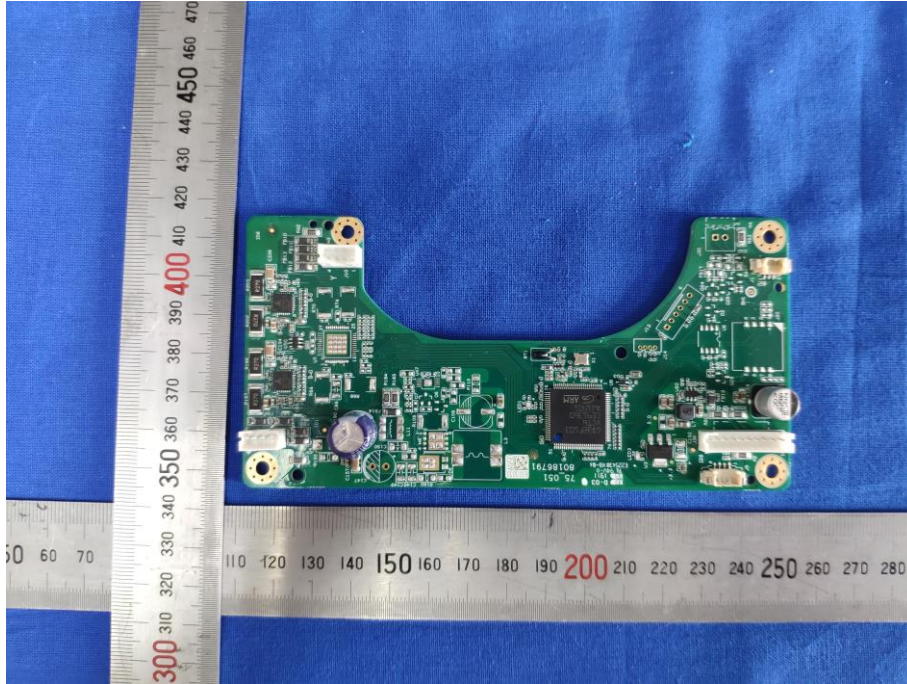



**BUREAU
VERITAS**

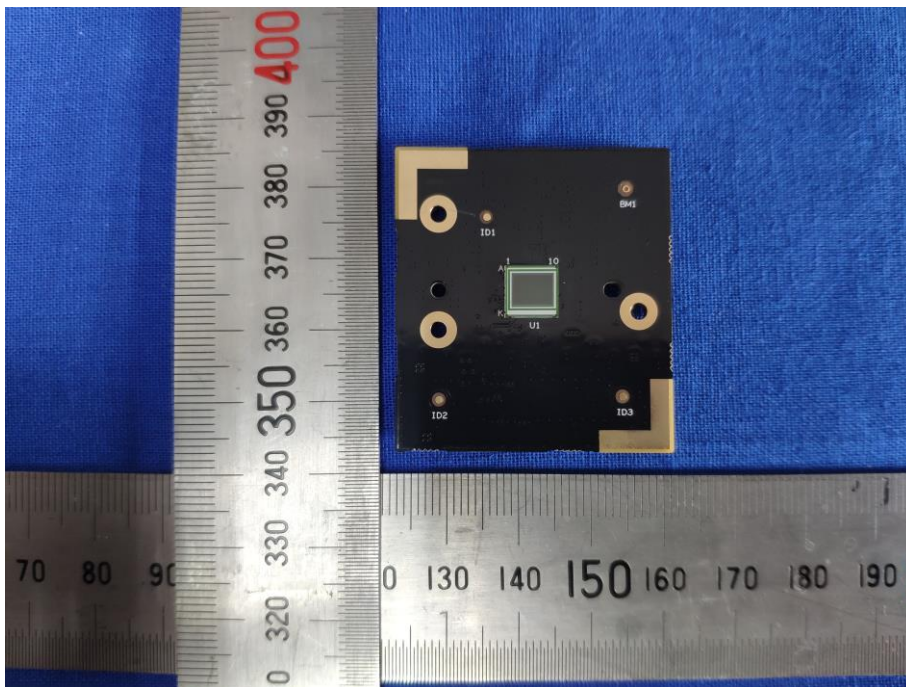
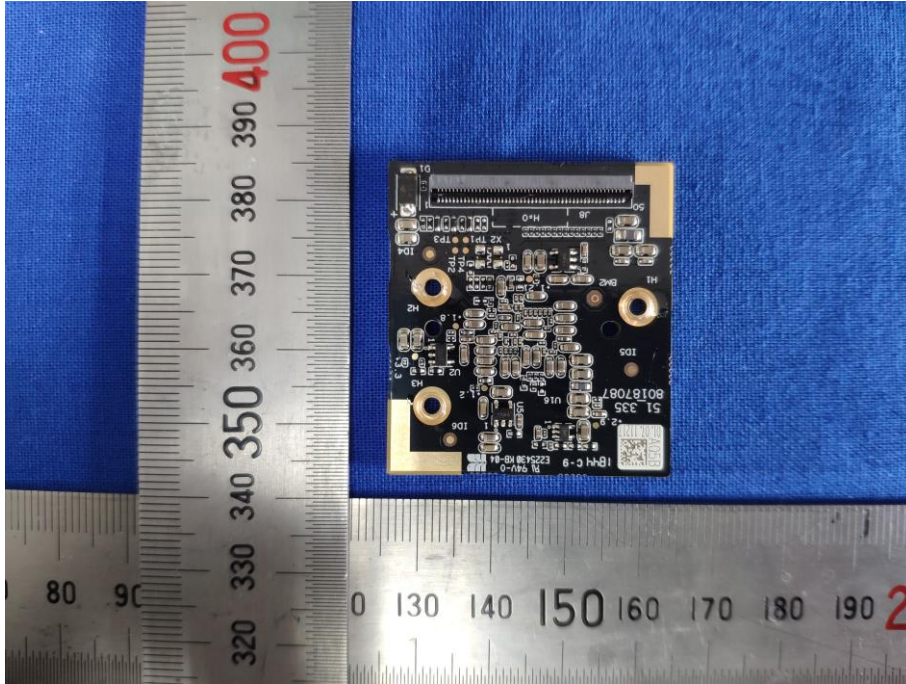



**BUREAU
VERITAS**

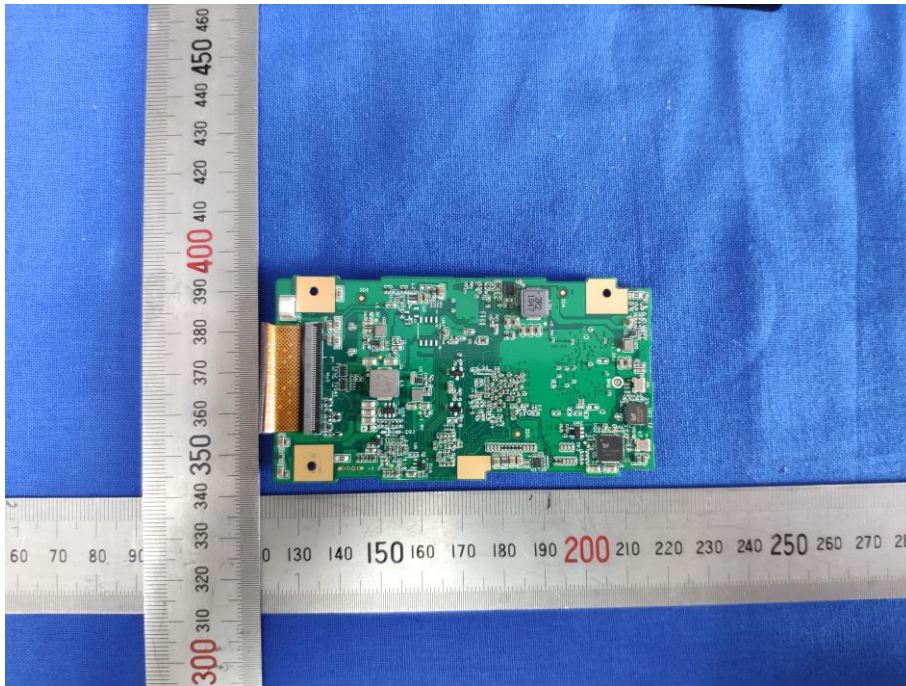
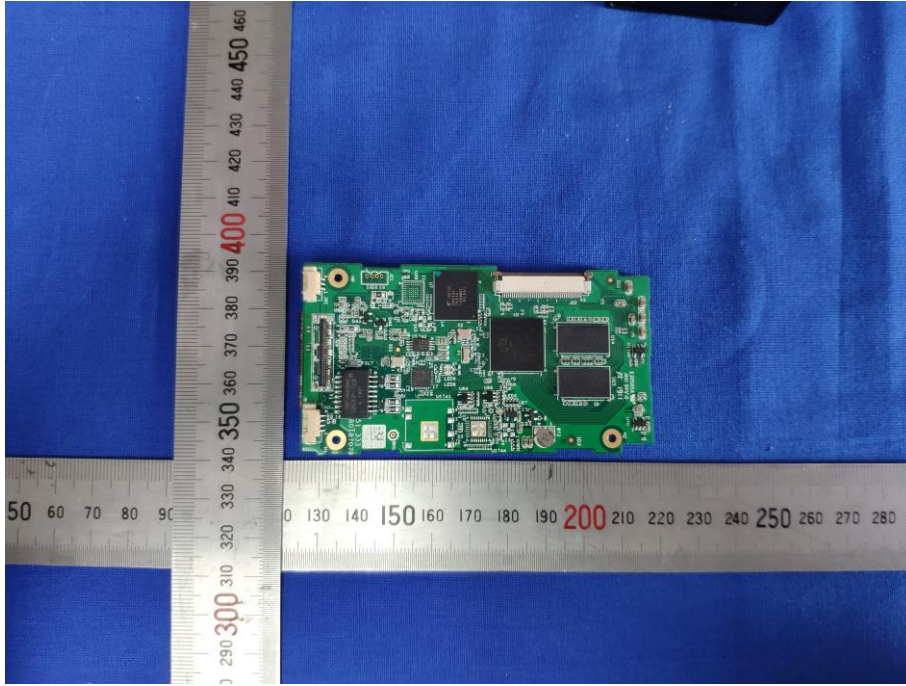



**BUREAU
VERITAS**

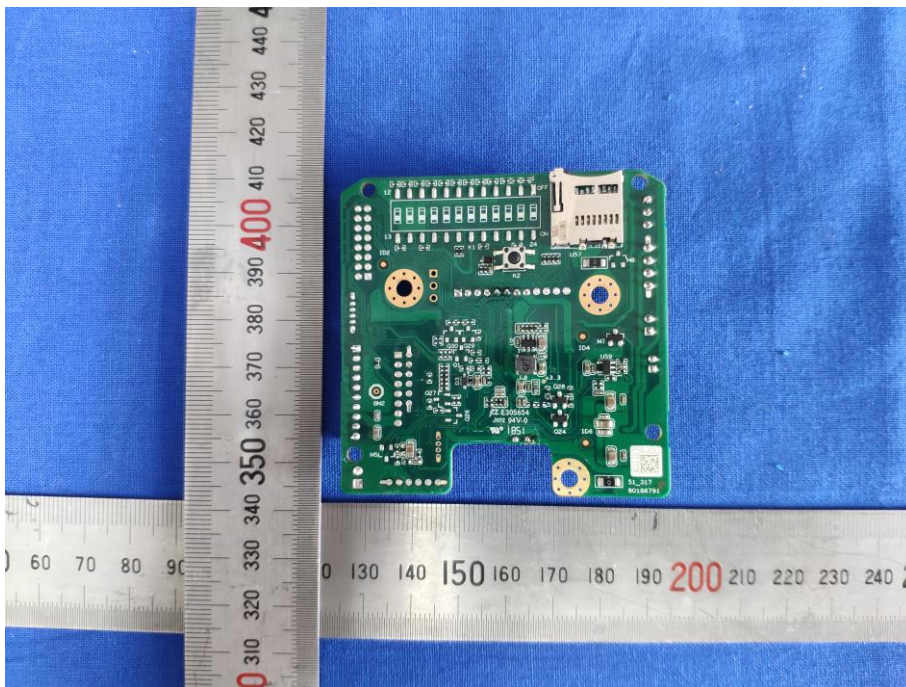
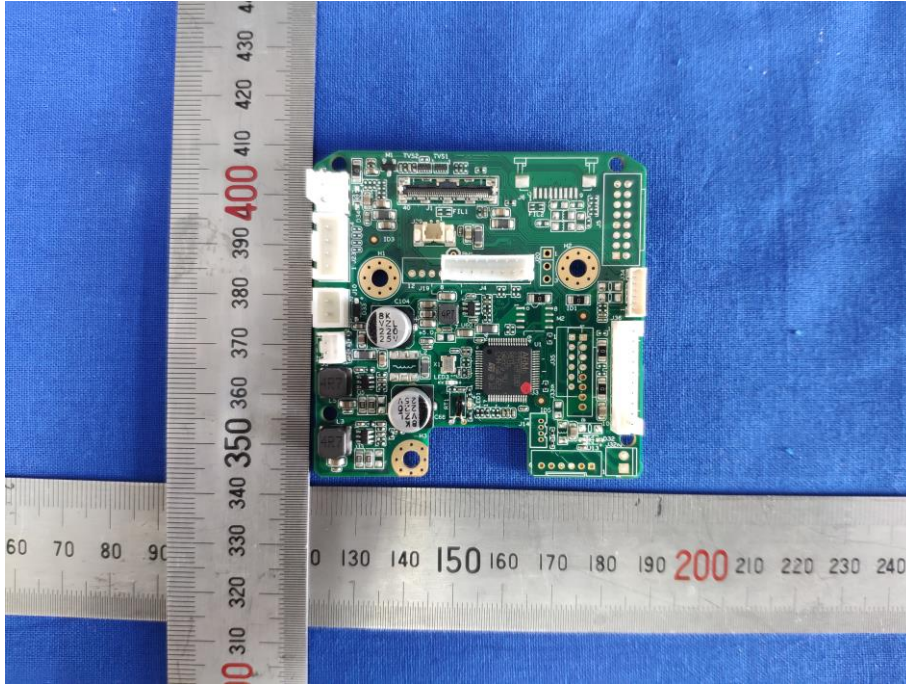



**BUREAU
VERITAS**

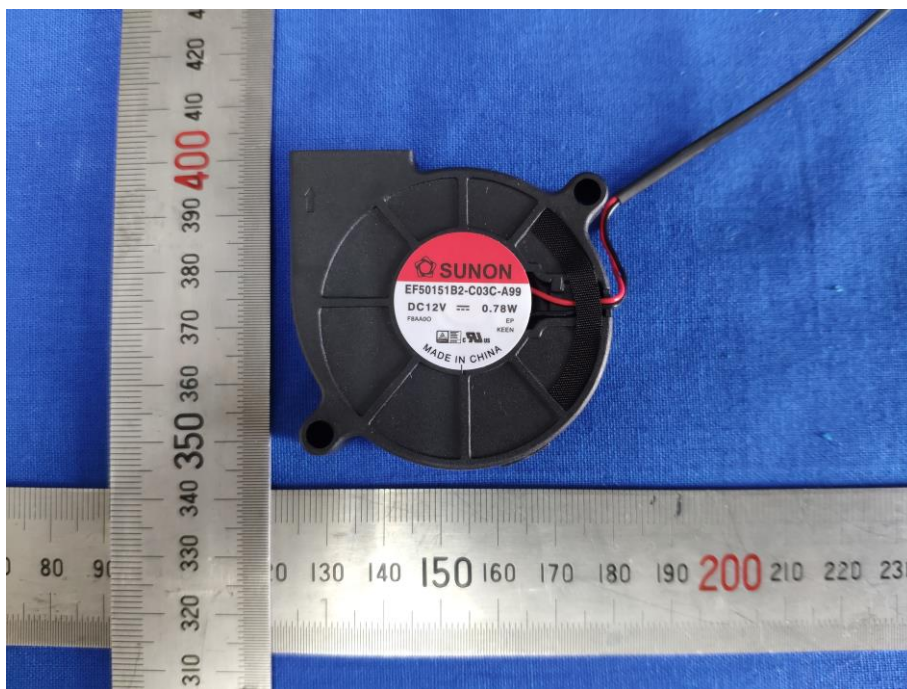
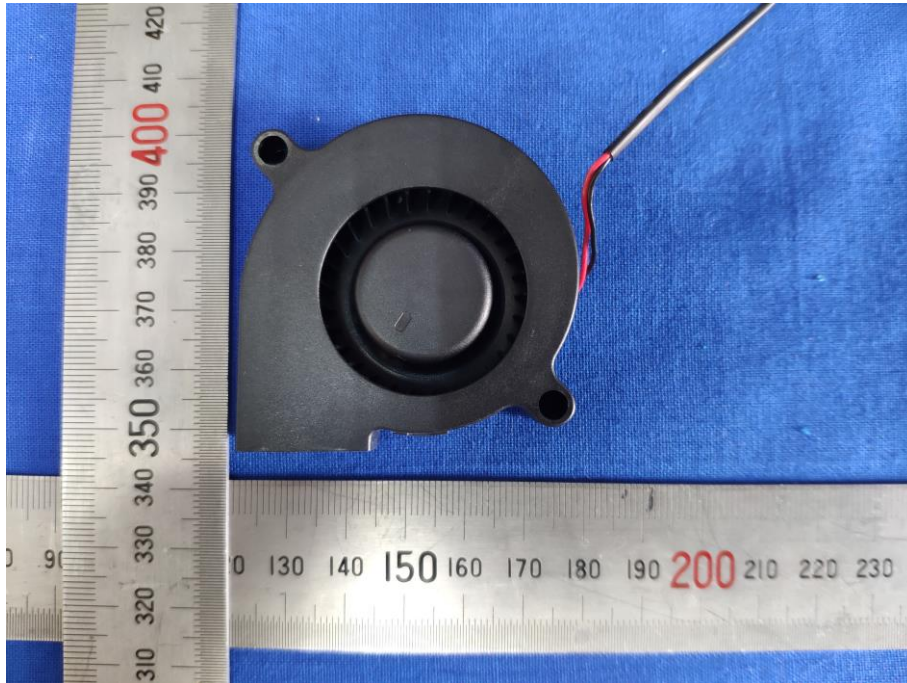

--- END ---