

FISA TEHNICA INDUSTRIAL



Industrial : usa de garaj sectionala cu deschidere verticala

Destinatie: garaj colectiv / hale industriale

Generalitati:

Sisteme de culisare **SL, SLR, LHF, LHR-RM, FTR, VL, HL, HL+FTR, HL-C, VL-C**, otel galvanizat, sine de culisare cu grosime 2 mm.

Arcuri torsiune galvanizate, garantate 25000 cicluri.

Panouri sandwich umplute cu spuma poliuretana, grosime 40 mm.

Etanseitate Laterala: cheder dublu.

Etanseitate Superioara: cheder dublu fixat pe profil de AL in panou superior

Etanseitate Inferioara : cheder "U" cu doua aripi fixate pe profil AL in panou inferior.

Dimensiuni: Customizat / La comanda, in limita :

L min: 1600mm ; **L max:** 8000 mm

H min: 1600 mm ; **H max:** 6790 mm

Produs Standard Manual:

- Sistem de culisare
- Profil "C"
- Arcuri de torsiune 25000 cicluri
- Cabluri, tamburi, ax gol/plin cu canal pana, cupla
- Dispozitiv siguranta impotriva ruperii arcurilor
- Dispozitiv de siguranta impotriva ruperii cablurilor
- Panouri Sandwich grosime 40 mm
- Pregaurire panouri pentru fixare balamale
- Feronerie galvanizata: Balamale si Capace laterale
- Suruburi/Holtzsuruburi: fixare/asamblare componente.
- Role cu rulment
- Cornier pregaurit pentru fixare in tavan: 3 ml (2 console pt Hgr max 500mm)

Produs Standard Electric:

- Sistem de culisare
- Profil "C"
- Arcuri de torsiune 25000 cicluri
- Cabluri, tamburi, ax gol/plin cu canal pana, cupla
- Dispozitiv siguranta impotriva ruperii arcurilor
- Dispozitiv de siguranta impotriva ruperii cablurilor
- Panouri Sandwich grosime 40 mm
- Pregaurire panouri pentru fixare balamale
- Feronerie galvanizata: Balamale si Capace laterale
- Suruburi/Holtzsuruburi: fixare/asamblare componente.
- Role cu rulment
- Cornier pregaurit pentru fixare in tavan: 3 ml (2 console pt Hgr max 500mm)
- Motor Industrial Axial (GFA, Marantec) / Motor Linear Sommer



Optional Manual:

- Yala blocare/deblocare
- Boltz
- Ferestre
- Panou ALU Vitrat
- Maner ingropat/aplicat
- Usa pietonala
- Profil "omega"
- Reductor cu Lant

Optional Electric:

- Yala blocare/deblocare
- Boltz
- Ferestre
- Panou ALU Vitrat
- Maner ingropat/aplicat
- Usa pietonala
- Profil "omega"
- Girofar
- Semafor ROSU / VERDE

Dimensiuni Sistem de Culisare:

SL

Latime stalp vertical Stg/Dr: 75 mm
Latime panou SL: L usa + 50 mm
H stalp vertical SL: H gol +200 mm
AD manual SL: Hgol + 650 mm
AD electric axial SL:Hgol +650 mm
AD electric linear SL: Hgol+1100

SLR

Latime stalp vertical Stg/Dr: 75 mm
Latime panou SLR: L usa + 25 mm
H stalp vertical SLR: H gol + 120
AD manual SLR: Hgol + 1140 mm
AD electric SLR: Hgol + 1140 mm
AD electric linear SLR: Hgol + 1600 mm

LHF

Latime stalp vertical Stg/Dr: 75 mm
Latime panou LHF: L usa +50 mm
H stalp vertical LHF: H gol + 110 mm
AD manual LHF: Hgol + 650 mm
AD electric LHF: Hgol + 650 mm
AD electric linear LHF:Hgol+1100 mm

LHR-RM

Latime stalp vertical Stg/Dr: 75 mm
Latime panou LHR-RM: L usa + 25 mm
H stalp vertical LHR-RM: Hgol + 80 mm
AD manual LHR-RM: Hgol + 700 mm
AD electric LHR-RM: Hgol + 700 mm
AD electric linear LHR-RM:Hgol + 1600 mm

FTR

Latime stalp vertical Stg/Dr: 75 mm
Latime panou FTR: L usa + 50 mm
H stalp vertical FTR: H gol + 200 mm
AD manual FTR: Hgol + 650 mm
AD electric FTR: Hgol + 650 mm

VL

Latime stalp vertical Stg/Dr: 75 mm
Latime panou VL: L usa + 50 mm
H stalp vertical VL: H gol + 250+500 mm
AD manual VL:500 mm
AD electric VL: 500 mm

HL

Latime stalp vertical Stg/Dr: 75 mm
 Latime panou HL: $L_{usa} + 50$ mm
 H stalp vertical HL: $H_{gol} + HL$ mm
 AD manual HL: $H - HL + 650$ mm
 AD electric HL: $H - HL + 650$ mm

HL+FTR

Latime stalp vertical Stg/Dr: 75 mm
 Latime panou HL+FTR: $L_{usa} + 50$ mm
 H stalp vertical HL+FTR: $H_{gol} + HL$ mm
 AD manual HL+FTR: $H - HL + 650$ mm
 AD electric HL+FTR: $H - HL + 650$ mm

HL-C

Latime stalp vertical Stg/Dr: 75 mm
 Latime panou HL-C: $L_{usa} + 50$ mm
 H stalp vertical HL-C: $H_{gol} + HL$ mm
 AD manual HL-C: $H - HL + 650$ mm
 AD electric HL-C : $H - HL + 650$ mm

VL-C

Latime stalp vertical Stg/Dr: 75 mm
 Latime panou VL-C: $L_{usa} + 50$ mm
 H stalp vertical VL-C: $2 * H_{gol} + 250$ mm
 AD manual VL-C: 500 mm
 AD electric VL-C: 500 mm

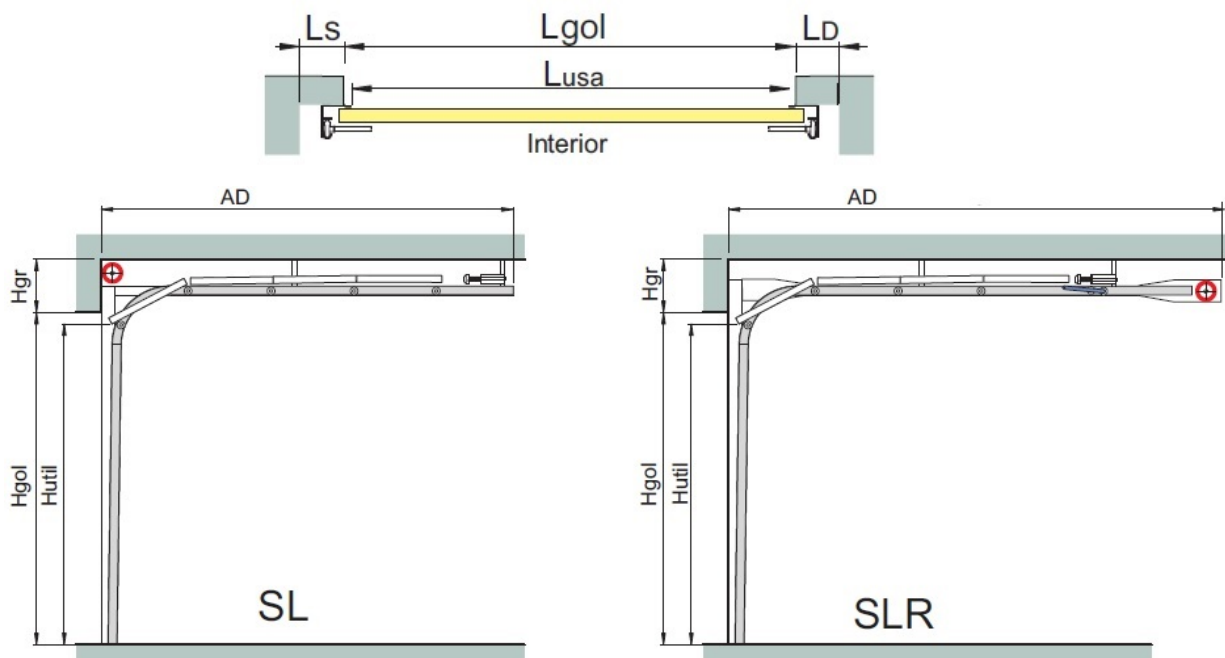

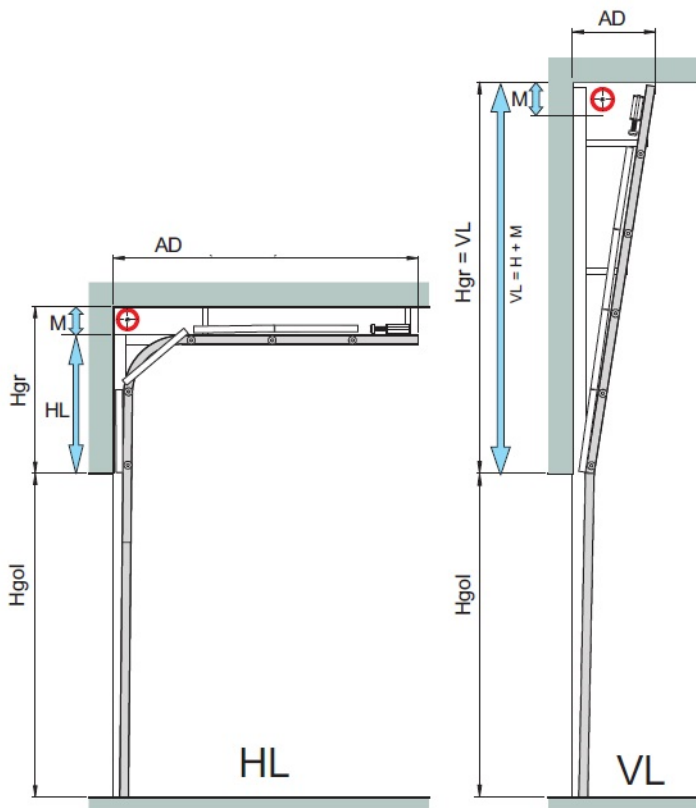
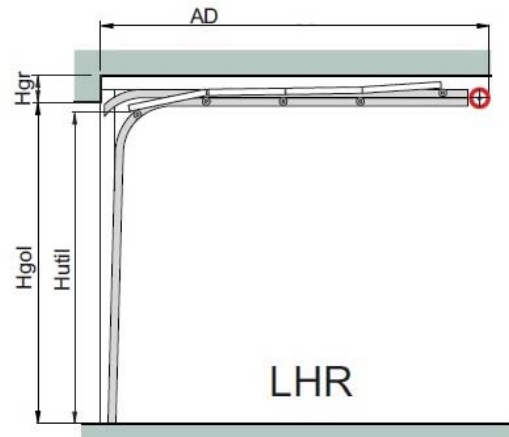
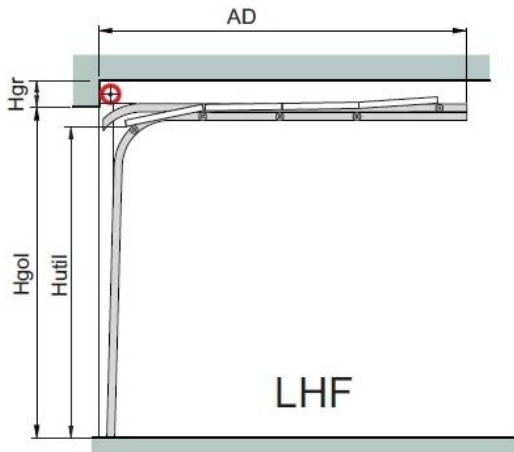

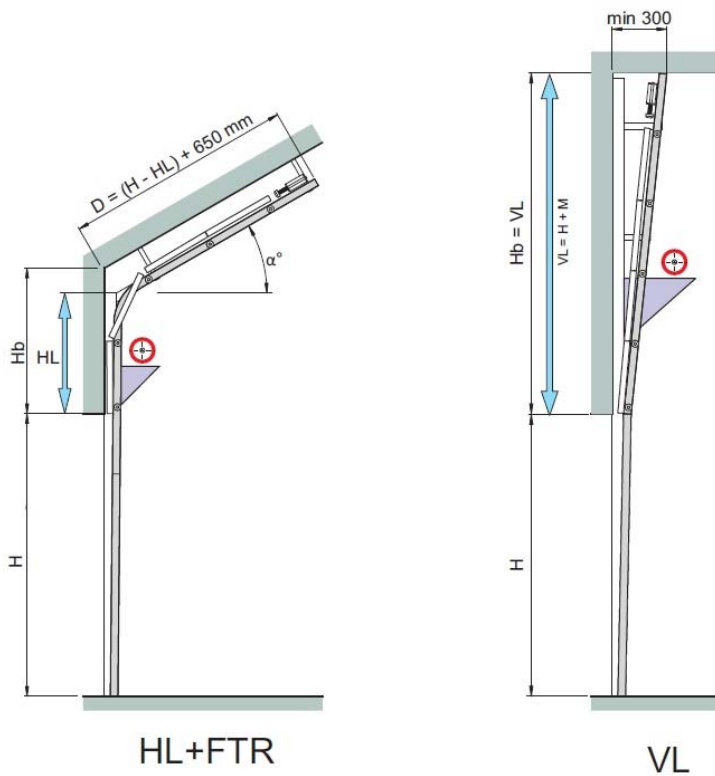
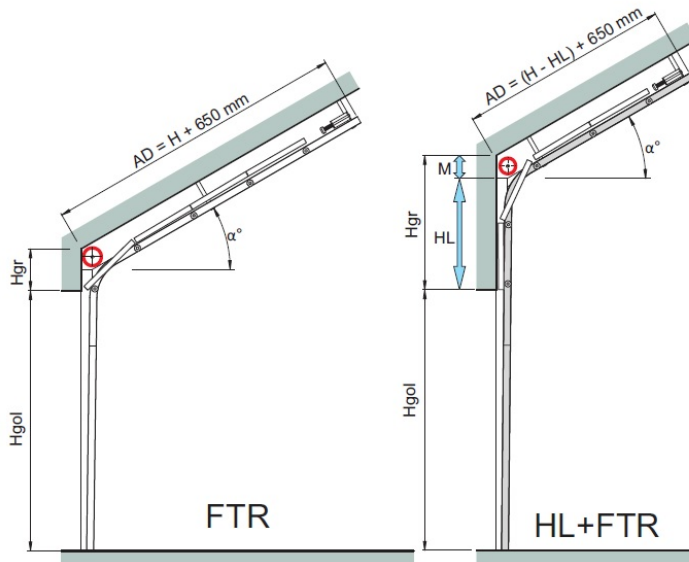



Dimensiuni si spatii instalare :

UȘI SECȚIONALE INDUSTRIALE

Lățime	Înălțime	Sistem de culisare	Hgr				Hutil			
			Manual	Reductor cu lanț	Electric șină	Electric axial	Manual	Reductor cu lant	Electric șină	Electric axial
L ≤ 5000	H < 3000	SL	280	320	320	320	Hgol - 120	Hgol - 30	Hgol - 20	Hgol - 30
		SLR	190	190	240	190	Hgol - 120	Hgol - 30	Hgol - 20	Hgol - 30
		LHF	240	280	240	260	Hgol - 100	Hgol - 30	Hgol	Hgol - 30
		LHR-RM*	120	150	260	150	Hgol - 180	Hgol - 160	Hgol-160	Hgol-160
L > 5000		SL	320	320	360	320	Hgol - 120	Hgol - 30	Hgol - 20	Hgol - 30
		SLR**	IM	IM	IM	IM	IM	IM	IM	IM
		LHF	280	280	280	280	Hgol - 100	Hgol - 30	Hgol	Hgol - 30
		LHR-RM*	120	150	260	150	Hgol - 180	Hgol - 160	Hgol-160	Hgol-160
L = Lmin÷Lmax	H = 3000÷3500	SL	420	420	IM	420	Hgol - 150	Hgol	IM	Hgol
		SLR **	190	190	IM	190	Hgol - 150	Hgol	IM	Hgol
		LHF	350	350	IM	350	Hgol - 100	Hgol	IM	Hgol
		LHR-RM*	120	150	260	150	Hgol - 180	Hgol - 160	Hgol-160	Hgol-160
	H > 3500	SL	420	420	IM	420	Hgol - 150	Hgol	IM	Hgol
		SLR**	190	190	IM	190	Hgol - 150	Hgol	IM	Hgol
		LHF	IM	IM	IM	IM	IM	IM	IM	IM
		LHR-RM*	120	150	260	150	Hgol - 180	Hgol - 160	Hgol-160	Hgol-160

*LHR-RM este permis doar până la Lmax = 6000mm

IM - imposibil de realizat

**SLR este permis doar pana la Lmax = 5000mm (pentru H>3000mm)

Spațiu necesar instalare Sistem de Arcuri (M) pentru FTR, VL	M = 420mm
Spațiu necesar instalare Sistem de Arcuri (M) pentru HL, HL+FTR	pentru Hgr < 800, M = 420mm pentru Hgr ≥ 800, M = 350mm

Dimensiuni Maxime/Minime		
	Maxim	Minim
Lățime [mm]	8000	1600
Înălțime [mm]	6790	1600
Suprafață [mp]	35	2.56

Sistem de culisare	AD (adâncime minimă)		Lățime stâlpi (LS, LD)			
	Electric șină	Manual/EL axial Reductor cu lanț	Manual	Reductor cu lant	Electric șină	Electric axial
SL	H gol + 1100	Hgol+650				
SLR	H gol + 1140	Hgol+1140	100/100	100/250	100/100	100/300
LHF	H gol + 1100	Hgol+650				
LHR-RM	H gol + 1600	Hgol+700	100/100	100/250	100/100	100/300
FTR	IM	Hgol+650				
HL	IM	H usa – HL + 650	100/100	100/250	100/100	100/300
HL+FTR	IM	H usa – HL + 650				
VL	IM	500				