

Pulse Vacuum Sterilizer

User Manual

Document No.: TD-XT-D004-001 V3.02

Revised Date: September 29, 2024

The Touch Screen software version is UCD0312-NH.

The PLC software version is UCD0311-N.



Please read the User Manual carefully before using this machine.

1. Before using the machine for the first time, the user should read through this Manual to properly understand the operation and maintenance of the machine.

2. Please keep the User Manual in its entirety for the duration of the equipment's use, and make sure that all updates received can be kept together with the User Manual.

3. In the event of a change in the site or organization where the machine is used, the User Manual must be transferred or handed over as part of the machine as a whole.

Safety Precautions

The machine is equipped with the necessary safety guards.

Termination or destruction of these safety devices is strictly prohibited to ensure the safety of personnel and equipment.

In case of emergency, turn off the main power switch, close the steam supply line shut-off valve (if available), and close the water supply line shut-off valve.

Important matters

- Please read this Manual carefully before use.
- All personnel should familiarize themselves with Chapter 1.
- Equipment installers should focus on reading and understanding Chapter 2 and 3.
- Sterilization staff should focus on reading and understanding Chapter 4 and 5.
- The quality control officer or nurse manager should focus on reading and understanding Chapter 6.
- Hospital equipment maintenance personnel should focus on reading and understanding Chapter 7.
- Equipment must be operated by authorized personnel. Operators must receive relevant training.
- As the equipment uses steam, take the necessary precautions against scalding before use.
- For proper operation, keep the machine clean.
- Regular maintenance of the equipment is required during the service of the equipment.
- Installation and maintenance must be carried out by trained personnel.

- In case of leakage of the equipment due to wear of the door gasket, etc., be sure to repair it immediately.
- Critical parts for the machine can only be obtained from factory, otherwise the normal operation of the equipment cannot be guaranteed.

Isolation Switch

The machine must be equipped with a separate power switch box, make sure the switch box is in a place close to the equipment and easy to reach by the operator. It must be installed and labeled according to the relevant standards.

Product Liability

© Copyright

The copyright of this Manual belongs to factory, without permission any unit or individual shall not copy and reproduce the content of this Manual, otherwise factory has the right to pursue the responsibility of the parties concerned.

Factory reserves the right to make product updates and is subject to change without notice. The information contained in this Manual is current at the time the manual was issued.

The equipment must not be modified or improperly operated without the permission of factory, and factory will not be responsible for any damages caused as a result.

Warning Symbols

Special attention needs to be given to the Attention, Warning and Danger symbols in this Manual.

Contents

1 Preface	1
2 Introduction	6
3 Technical Parameters	10
4 Installation and Commissioning	11
4.1 Equipment unloading	11
4.2 Unbox and inspection	11
4.3 Equipment Installation	12
4.4 Commissioning	16
5 Structure and working principles	19
5.1 Cabinet body	19
5.2 Cabinet door	20
5.3 Pipeline system	25
5.4 Control system structure principle	29
5.5 Working principle of the control system	33
4.6 Outer decorative plate	36
6 Use and Operation	37
6.1 Operation instructions	40
6.2 Parameter settings	43
6.3 Manual operation	48
6.4 Cycle running	49
6.5 Precautions for sterilization operation	50
7 Troubleshootings	52
7.1 Common failures and solutions:	52
7.2 Analysis and elimination of wet packages:	59
7.3 Analysis and troubleshooting on sterilization failure:	60
7.4 Unsolvable problems:	61
8 Maintenance	62

8.1 Safety precautions	62
8.2 Maintenance Plan	64
8.3 Maintenance guidelines	72
8.3.1 Inspection on the pressure vessel	72
8.3.2 Calibration on safety valves and pressure gauges	72
8.3.3 Check the correspondence between chamber temperature and chamber pressure	72
8.3.4 Check all pipes for leakage	73
8.3.5 Clean the sterilizer chamber, rails and filters	73
8.3.6 Clean the shelves	73
8.3.7 Clean the equipment surface	74
8.3.8 Check the equipment print records or monitoring data	74
8.3.9 Generator drainage(built-in generator equipment)	74
8.3.10 Leak test	74
8.3.11 Check whether the energy supply meets the Manual requirements ..	75
8.3.12 Check and clean the door gasket and door sealing groove	75
8.3.13 Clean all filters on the pipeline	76
8.3.14 Check the shelf push-pulling, whether the docking is smooth, whether the bolts are loose (if available)	77
8.3.15 Check and clean the maintenance space	77
8.3.16 Check printer	77
8.3.17 Check whether the fire wire, ground wire and zero wire are tight at the total power supply of the device	79
8.3.18 Check the wiring and terminal protection sleeve of the heating tube, vacuum pump and other strong electric parts	79
8.3.19 Generator water level probe (or float) and level gauge cleaning and descaling (built-in generator equipment)	79
8.3.20 Clean the generator boiler and heating tube (built-in generator	

equipment)	80
8.3.21 Check whether the generator level display glass tube shows correctly, check whether the liquid level meter gasket leaks (built-in generator equipment)	81
8.3.22 Clean the internal electrical components of the electrical box and equipment valve sensors, etc.	81
8.3.23 Check dry-burn protection (built-in generator units, if available)	82
8.3.24 Check the safety valve for water or steam leakage	83
8.3.25 Check for water leakage from the heating tube (built-in generator equipment)	83
8.3.26 Check all wires of the equipment	83
8.3.27 Check door safety, including all door position switches, barrier protection and hinge moving parts	83
8.3.28 Check that the upper limit of generator pressure is within the specified range (built-in generator unit)	84
8.3.29 Clean all traps on equipment and steam pipelines(if available)	84
8.3.30 Check and tighten check valves	85
8.3.31 Door moving parts lubrication and inspection	85
8.3.32 Pressure transmitter connection inspection and descaling	85
8.3.33 Check and clean the working fluid inlet and cavitation protection port of the vacuum pump, check the suction of the pump and run without leakage	85
8.3.34 Check the recent alarm records to find the cause and assess whether it is caused by component failure	85
8.3.35 Check PT100 for leaks, breaks, knocks and wiring problems	86
8.3.36 Check the pressure transmitter for water leakage, damage, bumping and wiring problems	86
8.3.37 Check the difference between the chamber temperature and the	

recorded temperature	86
8.3.38 Periodically clean all water tanks of the equipment (if available)	86
8.3.39 Check whether the equipment drainage pipeline is smooth or not ...	86
8.3.40 Vacuum pump cleaning and descaling	87
8.3.41 Check that equipment warning labels are complete and diagrams are clear and easy to see	87
8.3.42 Check that the Operating Guide of the equipment are complete	88
8.3.43 Check pressure safety interlock device	88
8.3.44 Check the front and rear door emergency stop switches (if available)	88
8.3.45 Confirm that all signal wires are not pinched when opening and closing doors	88
8.3.46 Confirm that all spare parts in the maintenance room are not affected by water vapor.	89
8.3.47 Confirm that the wire slot and terminal guard plate are complete and there is no potential danger of electric shock	89
8.3.48 Check grounding impedance	89
8.3.49 Check whether the generator low liquid level switch is effective	89
8.3.50 Check the integrity of the equipment and external pipeline insulation	90
8.3.51 Check the level of the front and rear door rails and fasten them	90
8.3.52 Check and clean the steam barrier	90
8.3.53 Check and clean all flow restriction joints (if available)	90
8.3.54 Check the vacuum pump shock pads are intact and stable	90
8.3.55 Check all valves for leakage	91
8.3.56 Check whether the key switch is in good contact or not	91
8.3.57 Calibrate the date and time of the equipment	91
8.3.58 Replace door gasket	91
8.3.59 Detect parameters such as temperature, pressure and time with a temperature and pressure tester	92

8.3.60 Replace generator water level gauge pad(built-in generator equipment)	92
8.3.61 Replace all clamp pads on the pipeline	93
8.3.62 Replace the air filter element	93
8.3.63 Remove and the clean bolts	93
8.3.64 Clean the printer thermal printer head	93
8.3.65 Check the integrity of the nameplate	93
8.3.66 Replace PLC Battery	94
8.3.67 Vacuum pump maintenance	94
8.3.68 Replace generator heating tube contactor (built-in generator unit) ..	94
8.4 Parts List	95
8.5 Common problems	97
8.5.1 How to check and replace the safety valve	97
8.5.2 Procedure for replacing the electric heating tube	97
8.5.3 Cleaning of solenoid valve	98
8.5.4 Cleaning of inlet and drain filters	99
8.5.5 Replace the water level detection device	99
8.5.6 Use and maintenance of the printer	100
8.5.7 Components to be maintained and replaced by specialized personnel only	101
9 Others	104
9.1 Self-protection	104
9.2 Sterilization quality assurance	104
9.3 Detection of sterilization effect	107
9.4 Energy saving and environmental protection	112
Appendix	113
Appendix A Operation Guide	113
Appendix B Installation Drawings	113

Appendix C Electrical Drawings 113
Appendix A Operation Guide 114

1 Preface

This Manual is applicable to the installation, operation and maintenance of **XG1. U Pulse Vacuum Sterilizer**.





Safety Warning Instructions:

Special attention should be paid to the Attentions, Warnings and Dangers in these Manual.

Attentions

- 1) **Keep the User Manual intact for the service life of the equipment;**
- 2) **Ensure that all updates received are saved in the User Manual;**
- 3) **In the event of a change in the site or organization where the equipment is used, it must be ensured that the User Manual is transferred or handed over as part of the equipment as a whole;**

Please learn more about the symbols posted on the equipment in the following list:

SN	Symbol	Contents
1		Hot surface, be careful of burns
2		Attentions, please follow the User Manual
3		Ground Mark
4		Dangerous voltage, disconnect the power supply before operation or maintenance.

In the Manual, the following symbols are used to indicate operational elements that should be given attention or high priority:



High attentions should be paid.



Observe or there will be damage to the equipment.



Must be strictly observed or personal safety is jeopardized.

Before performing any operation, maintenance, or servicing of the equipment, please read and fully understand each chapter of this Manual, especially those with the above symbols that should be given high attentions.

All personnel operating or maintaining the equipment should be trained in the operation and safe use of the equipment.

Failure to use the equipment in the manner prescribed by factory may jeopardize the protection provided by the equipment.

User Manual must be carefully stored to prevent loss or damage, even minor breakages should be avoided.

The operator is obliged to carry out technical repairs, replenish the parts of the User Manual, the table of contents and the relevant chapters that have been lost, damaged or have become inapplicable.



- 1) **No one, under any circumstances, may tear out or remove any contents from the Manual.**
- 2) **In the process of learning and using the equipment, if the user encounters any inconsistency with the contents in the Manual or any situation that is not covered in the Manual, please contact our company**

in time, we will answer your questions in time, and if necessary, we will upgrade or update the Manual for free.

- 3) This Manual should be kept in a ventilated and dry place, avoiding humidity and high temperature.



This equipment is not suitable for sterilizing liquids in tightly sealed bottles. If you want to sterilize liquids, please contact us and we will select a special sterilizer for you.



When sterilizing tightly sealed bottled liquids with this equipment, it is easy to burst the bottles due to operator's negligence or violation of operating procedures, seriously endangering the safety of people and equipment.



Chlorine ion is an important factor causing corrosion damage to stainless steel. If the sterilizer is used to sterilize items containing chlorine ions, the wall inside the sterilizer must be rinsed with water every day to avoid the deposition of chlorine ions on the internal corrosion of stainless steel, to fully extend the service life of the equipment.



If the sterilizer is used to sterilize items containing chlorine ions and the equipment is not cleaned every day as required, the service life of the equipment will be seriously affected, and the additional damage and accelerated deterioration of the equipment brought about by this will not be covered by our company!



Whenever you see a symbol  anywhere on the equipment, it is important to consult this Manual and other relevant documents in order to

ascertain the nature of the potential hazard and any countermeasures that must be taken.



When you see the symbol  anywhere on the equipment, it indicates that the surrounding temperature is high and take care to avoid burns.



- 1) The user of this product should carry out regular routine maintenance and periodic self-inspection during use.
- 2) The product user should carry out self-inspection of the product in use at least once a month and make a record. The user found any anomalies during self-inspection and routine maintenance, should dealt with them in time.
- 3) The product user should do regular calibration, overhaul, and make records for safety accessories (safety valves, pressure gauges, etc.), safety protection devices, measurement and control devices and related ancillary instrumentation.
- 4) The product operators and their related management personnel, should obtain the national unified format of the special operators certificate in accordance with relevant state regulations by the supervision and management of special equipment safety assessment before engaging in the corresponding operations or management.
- 5) The users of equipment should make special equipment safety, energy conservation education and training for operating personnel to ensure that special equipment operators have the necessary knowledge of special equipment safety, energy conservation. The product operators in the operation should strictly implement the operating procedures of special equipment and related safety regulations.



- 1) **This equipment meets the emission and immunity requirements specified in GB/T 18268.**
- 2) **This equipment is designed and tested according to Class A equipment in GB 4824. In domestic environment, this equipment may cause radio interference and need to take protective measures.**
- 3) **It is recommended to evaluate the electromagnetic environment before using the equipment.**
- 4) **It is prohibited to use this equipment next to a strong radiation source (e.g. unshielded RF source), otherwise it may interfere with the normal operation of the equipment.**

2 Introduction

Pulse Vacuum Sterilizers use moist heat steam as the sterilizing factor. The design service life of the product is 8 years (or 16,000 sterilization cycles) (Note: This design service life is the estimated period of failure based on the equipment agreed upon under the standard use of the environment, and has nothing to do with the failure rate in the process of actual use of the equipment, improper use of the equipment will also accelerate the damage of equipment). The equipment is designed to remove the cold air from the chamber in accordance with the specified sterilization process, and then take the saturated moist heat steam as the sterilization factor to realize the sterilization of the items that can be penetrated by the steam under high temperature, high pressure and high humidity environment for a certain period of time and under certain pressure. All the default process parameters of this equipment are determined under the load situation described in this cycle with the bacterial spores of Thermophilic Fatty Liver Bacteria Spores or microorganisms with equivalent performance under specific resistance (for details, refer to GB18281 and other relevant national standards) as the representative of microorganisms that can be sterilized, which can kill the bacterial spores.

Note 1: When the load to be sterilized may be infected with microbial resistance greater than the standard agreed resistance (for example, the mad cow disease pathogen carries microorganisms), it is necessary to adjust the sterilization pressure, sterilization time and other relevant process parameters according to the characteristics of the specific microorganisms, and can be used only after the corresponding process confirmation.

Note 2: Sterilization factor on the agreed microbial killing ability should be in the equipment and related facilities are in normal working condition in order to effectively ensure that the killing effect, such as equipment failure, external connection system failure, the sterilized loading and placement and so on may interfere with the killing effect of sterilization factors.

Note 3: Due to the continuous updating and upgrading of the load to be sterilized, the operator should verify that the load to be sterilized is suitable for sterilization in this equipment before proceeding with the operation, otherwise unpredictable damage may be caused to the equipment or the load!

The standard equipment of the following order numbers is suitable for use in this Manual:

Table 2-1 Dimensions and Weight

Model	Volume	Chamber size (mm)	Overall Dimensions	NW	Voltage
XG1.U	100L	400×850 (Φ×L)	1250×730×1660	260kg	11kVA
XG1.U	135L	500×710 (Φ×L)	1110×750×1742	400kg	11.5kVA
XG1.U	185L	500×950 (Φ×L)	1350×750×1742	460kg	11.5kVA
XG1.U	300L	632×1000 (Φ×L)	1415×890×1780	750kg	18kVA

- Design pressure: -0.1/0.25Mpa
- Sterilization working Temp.: 115~138°C
- Temperature display accuracy: 0.1°C
- Pressure display accuracy: 1Kpa
- Vacuum lower limit: -0.08MPa

Depending on the order number, the volume of the equipment may be different. The three types of equipment used in this Manual differ only in volume and power, all other parameters are the same.

Table 2-2 Weight Table of Main Components

Model	Volume	Body	Door
XG1.U	100L	70kg	10kg
XG1.U	135L	145kg	16kg
XG1.U	185L	200kg	16kg
XG1.U	300L	280kg	31kg



This sterilizer is only applicable to the sterilization of medical instruments and items that are resistant to high temperature and high humidity, and cannot be used for the sterilization of oils and powders such as vaseline!



It is strictly prohibited to use this equipment for the sterilization of liquids encapsulated airtight with glass bottles or glassware, because the operation or changes in temperature and pressure may occur liquid bottles burst, occurring personal and equipment hazards.

- Sterilizer cabinet door adopts radial bolt locking mechanism. The sealing ring is made of silicone rubber with good temperature resistance and elasticity. Door center is equipped with pressure safety interlocking device in line with the “Pressure Vessel Safety Technology Supervision Regulations” requirements issued by State Bureau of Quality and Technical Supervision - electromagnetic locks, in any case, only when the pressure of the chamber in $\pm 10\text{KPa}$ or less, you can turn the handwheel. The cabinet door is also equipped with a door closing travel switch, only when the door is locked, the operation cycle can be started. Therefore, the overall sealing of the cabinet door is good, safe, reliable and easy to operate.
- The touch screen adopts a new type of liquid crystal display, which can display graphics, dynamic text, and can dynamically display the workflow and time, temperature, pressure and other parameters during the work process, and can be specially configured according to the needs.
- The PLC adopts a modern new control device--programmable logic controller (PLC for short) for cycle control, with strong functions, high reliability, flexible use and so on.
- Adopt the air exclusion method of mechanical forced pulsating vacuum, and injects steam after several times of vacuum, completely eliminating the cold spot in the sterilization chamber, making the air exclusion amount reach over 99%, completely excluding the temperature “dead corner” and “small loading effect”, ensuring the reliability of the sterilizer. It completely excludes the temperature “dead corner” and “small loading effect”, which

ensures the reliable sterilization effect.

- The sterilizer has single and double door, the double-door sterilizer can implement the effective isolation of bacterial area and aseptic area, which meets the requirements of the national GMP standard for drug production and management.
- The main control parts and valves all use the world's leading brands of high-quality parts, greatly improving the stability and reliability of this type of equipment.
- The service life of equipment is 8 years (or 16000 sterilization cycles).



The correct installation of sterilization equipment has a very important role in the normal play of its performance, must not be ignored.

3 Technical Parameters

Name	Parameters	
Working Pressure	0.205MPa;	
Working temperature	134°C;	
Pulse counts setting range	0~99 times;	
Sterilization time setting range	0~9999s;	
Drying time setting range	0~9999s;	
Pulsation amplitude setting	Positive value 0MPa~0.1MPa	
	Negative value -0.1MPa~0MPa	
Water pressure	0.15~0.3MPa soft water;	
Voltage	380V±38V	Power is based on specific equipment order number
	50Hz±1Hz	
Environment temperature	5°C~40°C	
Relative humidity	≤85%	

Note: Other technical parameters refer to the equipment installation drawings, any changes in parameters should be based on the equipment installation drawings.

4 Installation and Commissioning



Correct installation of sterilization equipment plays an important role in its normal performance, must not be ignored.

4.1 Equipment unloading

The equipment arrived at the customer, in the process of lifting should pay attention to:

- Do not stand under the lifting equipment.
- Ensure that there is enough safety distance around the lifting equipment.
- Use qualified lifting appliances.
- Adjust the lifting appliance to find the center of gravity in order to lift the equipment horizontally.
- When lifting, attention should be paid to protect the outer packaging board.

4.2 Unbox and inspection

- After the equipment is unpacked, first check whether the model and name on the nameplate of the product match with the order form.
- According to the equipment packing list details to carefully check whether the equipment components are intact, there is no damage or loss, if so, you need to make a record and get in touch with our company in time.
- Check carefully whether the connection or fixed parts are loose due to long-distance transportation, and tighten them if so.
- Inventory and record the accessories carried by the equipment.

4.3 Equipment Installation

Before the installation of the equipment, if necessary, you can provide our company with the model number of the equipment purchased, in order to request the installation diagram. The installation process should be under the guidance of professionals by professional construction personnel.



Non-standard installation will bring harm to human life and property, and hinder the equipment's normal and reliable operation.

Our company is not responsible for the consequences arising from non-standardized installation.

1) Preparation and requirements before installation

- Installation space: Considering the operation and maintenance of the equipment, the height of the space where the sterilizer is installed should be not less than 2.9 meters; the distance between the left and right sides of the sterilizer and the wall should be not less than 0.5m; the depth of the loading/unloading direction of the sterilizer should be not less than 1.5 times of the length of the sterilizer, so as to facilitate the handling of sterilized items. When installing a single-door sterilizer, the distance between the non-operating end and the wall should also be not less than 0.5m.
- Foundation: the surface should be solid and level, and the load-bearing capacity should meet the requirements of the corresponding equipment. If installed above the second floor, the ground bearing weight should be accounted for by the building design institute according to the total weight of the equipment operation, and if the bearing weight is insufficient, it should be reinforced, and the total weight of the equipment operation should be calculated according to 1.5 times of the weight of the equipment.

- Ventilation and heat dissipation: In order to better ensure the normal operation of the equipment as well as a comfortable working environment, it is recommended that a set of suitable ventilation system should be installed in the working room to control the ambient temperature and humidity around the sterilizer.
- Drainage: Choose than the sterilizer configuration of the drain port size of at least one specification of the drain, the drain will be led to the gutter alone to discharge outdoor, not with other drainage pipes in the building (such as cleaning, floor drains, etc.), otherwise the equipment in the process of the work of some of the gases discharged will affect the other rooms. Otherwise, is recommended to order steam cooling system.



Drainage pipeline should be installed from the equipment drain from high to low, there can be no back pressure, otherwise it will affect the sterilization or drying effect due to the poor discharge of condensate. When more than one set of equipment share a total drain, the flow rate of the total drain should be greater than the sum of the drain flow rate required for each piece of equipment. The drain pipe material should be selected as high temperature (140°C), corrosion-resistant and anti-aging material. When the equipment is installed, the ground bolts should be adjusted to ensure that the main body of the drain at the lowest point.

- Water source: for water ring vacuum pumps and steam generating units. The interface size is 1/2 inch female thread, pressure requirement: 0.15 to 0.3MPa, flow rate requirement see installation diagram. A valve and a 0-0.6MPa pressure gauge should be connected to the inlet pipeline during installation. (Note: If the water source pressure is higher than 0.4MPa, the range of the pressure gauge should be increased accordingly to ensure that the pressure gauge works at 2/3 of the full range.)



If the water source pressure is below 0.1 MPa, the vacuum cycle cannot be started.

- Water quality

Vacuum pump water: tap water or softened water with hardness less than 2mmol/L.

Generator water (applicable to electric-heating equipment): Quality indexes of supply water are shown in the following table

Table 3-1 Quality Index

Item	Index
Evaporation Residue	≤10mg/L
Silicon Oxide (SiO ₂)	≤1mg/L
Iron	≤0.2mg/L
Cadmium	≤0.005mg/L
Lead	≤0.05mg/L
Heavy metals other than iron, cadmium and lead	≤0.1mg/L
Chloride ion (Cl ⁻)	≤2mg/L
Phosphate (P ₂ O ₅)	≤0.5mg/L
Conductivity (25°C时)	≤5 uS/cm
pH value	5.0~7.5
Appearance	Colorless, clean, no precipitation
Hardness (total alkaline metal ions)	≤0.02mmol/L

Note: The data in the table is quoted from WS310.1-2016 Appendix B



The water used for the steam generator carried by the equipment itself must meet the requirements.

- Power supply: conventional equipment power supply AC380V should be three-phase five-wire system, three-phase fire wire, a zero line, a ground line. Where the zero line is blue, the ground line is yellow-green, the three fire wire is red, yellow and green, the user's power supply and the load capacity

of the power line, should be greater than the load of the equipment. The right side of the sterilizer or right behind the wall should be installed a power switch box, to ensure that the switch box is in close proximity to the equipment, and easy to reach for the operator, the switch box should be labeled as special for sterilizer. The switch box must be installed with a three-phase switch (or circuit breaker) and an overcurrent protection device to realize the function of power on/off and overcurrent protection of the equipment. Specialty equipment is wired in accordance with actual contract requirements for power.

- In order to ensure personal and equipment safety, a ground wire must be laid, and the ground wire in the equipment enclosure and control cable must be reliably connected to the external ground.
- The piping and wiring provided should be horizontal and vertical and effectively fixed.



The equipment and generator shell must be strictly grounded!

Precautions:

- If the temperature of a terminal or enclosure of a field junction box or terminal block exceeds 60 °C under normal conditions at an ambient temperature of 40 °C or at the maximum rated ambient temperature (if higher than 40 °C), the minimum rated temperature of the cable to be connected to this terminal should be marked. The sign should be visible before or during connection, or the sign should be marked near the terminal.
- Do not place the equipment in a position where it is difficult to operate the disconnecting device.
- Avoid heavy dust, oil mist containing conductive particles, corrosive gases, flammable gases.

- Avoid environment that is susceptible to electric shock or vibration.
- Avoid high temperature and high humidity or easily wet by rain.
- Avoid environment of strong magnetic field.

1) Equipment in position

- Move the equipment to the selected location. During the moving process, do not damage or scratch each decorative cover. In case of special circumstances, make a record and mark, remove the pipeline and outer cover, and restore the equipment as it is in place.
- Remove the bag, take out the documents and keep them properly.
- Do not scratch the original floor during handling.

2) Adjustment

The equipment can be placed directly on the level ground, such as slightly uneven, can be padded with a thin piece of iron to adjust properly.

3) Water, electricity, gas connection

According to the specific installation location of the equipment and installation requirements, the water, electricity and sterilizer connected to each other. In the pipe joints should be used sealing filler to prevent leakage, there shall be no water and other condensable liquids drip above the electrical box.



The ground wire of the power supply must be grounded reliably!



When installing the equipment, please install a leakage protection device to prevent safety problems caused by damaged parts.

4.4 Commissioning

The equipment has been pre-set with part of the cycles in accordance with the relevant standards when it leaves the factory. During the commissioning process, the user can modify the cycle parameters according to the requirements of use. For

specific parameter settings, please read Chapter 5 “Use and Operation”.

- Before commissioning, you should check whether the electrical part of the wiring, sockets, etc. are off, loose, if so, tighten them; whether water inlet, drainage, connection is correct, otherwise adjust and tighten.
- Open the water inlet valve to ensure that the water source pressure meets the requirements.

1) Vacuum pump rotation direction

Open the power switch, log in with administrator or above authority, enter the manual operation state, click the auto/manual switching button, click the vacuum pump at this time the vacuum pump starts. Observe whether the rotating direction of the vacuum pump motor fan is clockwise, otherwise any two load lines on the three-phase load switch should be switched.

Note: If two people cooperate with each other during this operation, the reversal time of the vacuum pump will be reduced.

2) Check the valves

Under the manual state, click the corresponding label of the solenoid valve (F2 inlet valve F3 vacuum valve F4 air-break valve F5 slow discharge valve F6 water injection valve F7 pump valve), open the solenoid valve, and gently approach the top of the solenoid valve with a screwdriver, you should feel a strong magnetic attraction.

3) Empty-load test

- Before running the cycle, do leak test according to the instructions in Chapter 5, Use and Operation. If the test fails, there is a leak in the pipelines connected to the chamber. At this time, it is necessary to carefully check, eliminate the leakage point, retest until the test is qualified, otherwise it will affect the sterilization effect of the equipment.
- Parameter settings: refer to the working parameters of the cycle in Chapter 5 “Use and Operation” .
- After setting the parameters, run the fabric, instrument and BD test cycle, please

read Chapter 5 “Use and Operation” for the specific cycle process. During cycle running, should check the pipeline and door sealing, and deal with them if found pipeline leakage of steam in time.

4) Load Test

The above cycles run with empty load, and run the load test after the completion of the no-load test. In the load test, instruments and fabrics and other non-liquid sterilized items should be loaded with no more than 80% of the volume of the chamber, and should be placed on the shelf, the dressings package and instrument packages should maintain a gap of 10mm. The load test shall detect the sterilizing effect at the center point inside the package. Do the B-D test cycle, chemical test, and biological test on the sterilizer as described in Chapter 9, and observe the test results.



Allow this sterilizer to modify the cycle during commissioning according to actual conditions.

5 Structure and working principles

The product consists of cabinet, cabinet door, two shelves, pipeline system and control system. Adopt saturated steam as a medium, under high temperature conditions, to achieve the effect of disinfection and sterilization, and set the pulse counts according to the demands. See Appendix Figure 3: General Assembly Diagram.

5.1 Cabinet body

- The outside of XG1.UCD-100M cabinet adopts electric heating film to ensure that the inner cabinet to maintain a certain temperature in order to reduce the condensation of condensate in the internal sterilization process.
- XG1.UCD-135M/185M/300M cabinet adopts double-layer jacket structure to ensure that the inner cabinet maintains a certain temperature to reduce the condensation of condensate in the internal sterilization process.
- The inner cabinet is made of imported stainless steel plate with excellent anti-corrosion performance, which is automatically welded by special welding machine, and the surface is processed by mechanical polishing and electrochemical polishing, which is bright and smooth, corrosion-resistant and durable.
- The cabinet uses high-quality thermal insulation material on the surface of the outer cabinet board, which is not only beautiful and durable, but also can make the heat radiation of the equipment reduced to a minimum, effectively ensuring the working environment of the equipment.

5.2 Cabinet door

The cabinet door of this series of sterilizers mainly consists of door plate, door bolt and locking mechanism, sealing ring, hinge plate, door cover, handwheel, pressure safety interlocking system and control elements and other components.

1) Door-open direction:

The operating end is called the front door, and the non-operating end is called the rear door (only for double-door sterilizers). Conventional configuration for the single-door for the left open, double-door for the front door right open, the rear door left open.

If users need to change the direction of the door, some of these functions need to be reversed according to the following introduction to the operation.

2) Door cover removal:

First, take off the logo in the middle of the handwheel, and then use the crosshair screwdriver to remove the screw in the center of the decorative cover, at which time the handwheel seat can be removed. Then remove the screws on the upper left and lower right of the door cover, and then grasp the two sides of the door cover and lift it upward after breaking it slightly outward, and then the door cover can be removed at this time.

3) Door bolt and locking mechanism:

The locking of the door is driven by manual rotation of the screw through the rotating door handwheel, so that the nine bolts outward to complete.

The bolt gasket has been adjusted when leave factory, if air leakage founded, the users should not adjust by themselves, it must be carried out by professional personnel.

- Close door

Before closing the door, each bolt is in full contraction position, i.e., the door handwheel is turned counterclockwise to the limit position. Close the door, so that the

handwheel clockwise rotation, the bolt automatically extends, and inserted into the front cover plate, and then continue to rotate the handwheel, when the operator hears the door cover door switch is pressed together “click” sound, continue to rotate half a circle to a circle can be completely pressed together.



It is strictly prohibited to rotate the handwheel clockwise under the door opening to prevent the door bolt from extending outward, otherwise can cause damage to the equipment cover and cabinet door!

- Open door

Rotate the handwheel left to the limit position to open the door.



Note: The door will only open if the pressure in the chamber is equal to atmospheric pressure!

- Door switch

Door switch is installed inside the door cover, and run by the door bolt compression. For double-door cabinet, each the front and rear door have a door switch, only when the front and rear doors are closed tightly can the cycle start, if the door is not closed tightly then the cycle can not start to run, so as to avoid the phenomenon of the cabinet door is not closed tightly on the start of the machine. In case of special circumstances, you can adjust the pressure plate on the door bolt, you can adjust the sequence of the door switch action.

4) Pressure safety interlock:

The cabinet door is equipped with double insurance. In the lower left of the door plate is equipped with one travel switch, this switch is pressed down before the door is locked tightly, connected to the equipment cycle control circuit, that is to say, the cabinet door is not locked tightly, the cycle will not be able to start. When the cycle starts, the electromagnetic lock pops out (front door and rear door are popped out for double-door equipment), at this time the handwheel can not be rotated, the door can

not be opened. When the sterilization cycle is completed, the chamber pressure drops to within $\pm 10\text{KPa}$, the electromagnetic lock is withdrawn and the door can be opened.

5) Post-half

For manual-door equipment that used two years or longer, part of the post-half two positioning pins and cam spiral groove long-term abrasion of more serious consequences, especially in the rear-half two positioning pins, which can lead to serious breakage from the root, the door can not be used normally. The above phenomenon is mostly related to the operator: such as the cabinet door is located in a bad position, and forced to close the door, too much force and its parts of the consequent abrasion, wear and tear will lead to the cabinet door can not be used at all. Therefore, switching the door strength should be moderate, to prevent damage to the transmission components.

6) Sealing gasket

- Structure: The gasket is a specially processed annular anisotropic silicone rubber ring, and the composition of its material, the design of its shape, its proper installation and maintenance are crucial to its normal operation as well as its service life. The gasket used by our company adopts a specially formulated silicone rubber material, which effectively ensures its stability and reliability under high temperature working environment.
- Principle: The gasket is fixed on the main body sealing ring seat, when the cabinet door in the process of closing, the gasket tightly attached to the cabinet body front sealing plate by external forces, due to its sealing surface for the trapezoidal shape, in the process of sealing will produce a certain amount of deformation, to achieve the sealing of the door.
- Maintenance: Although the gasket has been designed and selected with the long-term use, the following factors may affect the service life, which should be avoided as much as possible to ensure a longer service life:
 - a. At the end of a shift, should timely turn off the sterilizer steam control

valve, so that the cabinet door in the open position, otherwise due to the gasket for a long time in the high temperature under pressure, will inevitably make its gradual aging.

- b. After used for half a year to a year, the gasket should be removed, gently scrubbed with alcohol, dry with the sealing pressure strip together with the cabinet door mounted back to the end of the door panel.
 - c. In the process of use, pay attentions to preventing hard objects on the gasket collision, otherwise it is very easy to cause its permanent damage, so as not to achieve a reliable sealing
 - d. In the process of use, often on the gasket and the surface of the door plate to scrub will extend the service life.
- Failure: When the following reasons occur, it can be basically determined that the gasket has failed.
 - a. The surface of the gasket is obviously hardened, and when pulled, it feels that it has lost its elasticity, and there is a net-like pulling pattern.
 - b. The gasket has cracks or has been broken.



Note: The judgment of gasket failure or not, should be considered comprehensively, which has a great relationship with the long-term accumulation of experience of the operator!

- Removal and Installation:

When removing the gasket, stop all running cycles and open the door and remove the rubber strip from the ring seat sealing groove.

When installing, just re-squeeze the sealing compression strip into the sealing groove. NOTE: Because the circumference of the sealing compression strip is generally a little more than the circumference of the sealing groove, when installing, spread the excess length evenly in the sealing groove.

Note: Installation of the seal can be made easier with the help of another person!

7) Troubleshooting: (see Table 5-1)

Table 5-1 Cabinet Door 1 Troubleshootings

Failure	Reasons	Solutions
Cabinet door cannot open	Pressure in the chamber	Wait for the chamber pressure returns to zero, and then open the door
	Cycle is running	Exit the sterilization cycle
	Chamber temperature higher than door-open set temperature	Wait for cooling to the temperature range, then open the door
	Electromagnetic lock failure	Check the electromagnetic lock and its wiring
Cabinet door cannot lock	Cabinet door position changes and door sag occurs	Adjust the position of the cabinet door relative to the front cover plate
	Door bolt not fully retracted	Rotate the handwheel to fully retract the door bolt
	Drive system inside the door damaged	Check the drive system inside the door
	One of the door bolts is stuck against the front sealing plate and cannot be extended	Adjust the bolt carrier position or the height of the washer
Steam leakage around the door during operation	Door gasket are worn or deteriorated	Replace the door gasket
	Dirt in the area where the door strips are pressed together	Clear the position of the door strips

	Door not closed tightly	Reposition the door after deflating the chamber
	Uneven force on the bolt	Adjust door bolt carrier washer height

5.3 Pipeline system

1) Jacket steam inlet pipeline

Equipment that generates steam by its own steam generator, by heating the softened water in the steam generator to produce steam, the outlet of the upper part of the steam generator is connected to the interface of the lower part of the sterilizer cabinet, and the generated steam enters the jacket through the interface, and the steam in the jacket can effectively isolate the influence of the outside cold air on the chamber, and also maintain the temperature of the chamber in order to reduce the condensation of the steam in the chamber.

- The steam generator is designed to perform at its best with the following optimal configurations:
 - a. The body is made of high-quality seamless steel pipe and carbon steel plate for pressure vessel, welded by carbon dioxide flux-cored wire protection, with good weld quality and high overall strength.
 - b. The electric heating pipe is made of stainless steel tube, which features small volume and long service life.
 - c. The water pump is made of high-quality temperature-resistant and high-pressure pump, which is characterized by small volume, high out port pressure and reliable operation.
 - d. The liquid level is controlled by three probes, upper, middle and lower, and the liquid level in each working stage is displayed through the glass tube water level meter on the outer decorative cover.
- Steam generator can realize the following various automatic control

functions:

- a. Automatic water filling function: In the working process, due to the continuous output of steam, the steam generator body water level drops, when lower than the high water level for three minutes, the water pump is automatically turned on to refill the water to the normal working level (water level); when the water level rises to the normal working level, the water pump is turned off, to stop filling the water, so that it is uninterrupted to provide steam. When the water level reaches the low water level in sterilization stage then start water refilling.
- b. Pressure automatic control function: when the generator steam pressure reaches the upper limit set by the controller, it can automatically cut off the heating power supply; when the generator steam pressure is reduced to the lower limit set, it can automatically connect the heating power supply to ensure that the steam is output at a basic constant pressure.
- c. Water shortage automatic protection function: due to accidental reasons caused by the body of the water level drops to the lower water level, can automatically cut off the heating power supply, to ensure that the electric heating tube will not be damaged due to lack of water dry burning.
- d. Overpressure automatic protection function: when the pressure in the body due to accidental reasons exceeds the upper limit of the pressure set by the safety valve, the safety valve can be effectively and timely release to protect the equipment and the safety of the operator.

2) Chamber steam inlet pipeline

Jacket steam enters the chamber through the chamber inlet valve F2 to sterilize items.

3) Vacuum pipeline

This pipeline is to discharge the air, steam and condensate in the chamber through the lower steam port of the chamber, through the vacuum valve F3, into the

vacuum pump, and drain through the pump outlet.

- Vacuum valve F3: this valve is controlled by the executive program to open or close.
- Vacuum pump: the pump is a water-ring vacuum pump, which is the main equipment for vacuum, and it uses clean water as the working liquid. During the working process of the pump, the working liquid will form a water ring around the leaf, and the water ring plays the role of sealing and heat conversion, so it should be replenished constantly during the working process.

Note: The ultimate vacuum of water ring vacuum pump is directly related to the temperature of water ring and the compression ability of pump, the lower the water temperature, the higher the ultimate vacuum, so the water supply temperature of the pump is required to be as low as possible, the highest is not more than 25°C.

4) Drainage pipeline

Chamber drainage pipeline, condensate generated by the steam in the chamber is discharged through the discharge port below the front of the chamber via the filter, 1/4 solenoid valves, 1/4 ball valves, and one-way valves to the drain port, which automatically discharges the condensate in the chamber. Steam cooling system can be ordered as option.

One-way valve: a valve that allows only one-way flow of media, installed in the door vacuum pipeline and the chamber drainage pipeline. The the spring failure, sealing rubber gasket rupture or nut loosened off are common failures, making sealing groove into the water or the chamber water and steam return, the valve is a straight-through check valve, to prevent the outside steam or water into the chamber, affecting the working performance of the equipment.

5) Upper steam-out pipeline

Chamber upper steam-out pipeline, the chamber steam through the chamber front lower exhaust steam port through the filter, 1/2 solenoid valve, one-way valve to the drainage port, to remove the chamber steam, until the chamber pressure drops to

below 30KPa, you can carry out the vacuum action.

The upper steam-out pipeline and the drainage pipeline share the same solenoid valve.

6) Air inlet pipeline

After the air is filtered out by the HEPA filter to remove impurities and bacteria, it enters the chamber through the solenoid valve F4 to eliminate the negative pressure formed at the late stage of the work, so that the incoming air is dry and sterile, and prevent the secondary pollution of sterilized items.

Air filter: the air filter is cylindrical and adopts high-precision medical filter paper with a filtration precision of 0.2 μ m, which can filter out the bacteria and impurities in the air.

7) Water supply pipeline

Water supply pipeline: pure water enters the generator through the filter, water inlet solenoid valve and water injection pump F6, and tap water enters the vacuum pump for circulation through the water valve of pump F7. Filter: The filter can effectively stop and precipitate the solid debris carried by the water transportation pipeline in the barrel filter to prevent it from entering the equipment.

8) Pressure control pipelines

The series equipment fitted with accessories such as pressure transmitters, platinum RTDs, jacket and chamber pressure gauges.

- Pressure transmitters: please refer to the structure principle section of the control system.
- Platinum RTD: also called Pt100, please refer to the structure principle section of the control system.
- Safety valve: the evaporator and the inner chamber are respectively equipped with safety valves, which play the role of final safety protection when the operation is improper or the equipment has abnormal pressure. When the pressure is higher than its upper limit setting value, it will automatically

open to reduce the pressure; when it is lower than the lower limit setting value, it will automatically close.

- Safety valve: the generator and the chamber are respectively equipped with safety valves, which play the role of final safety protection when the operation is improper or the equipment has abnormal pressure. When the pressure is higher than its upper limit setting value, it will automatically open to reduce the pressure; when it is lower than the lower limit setting value, it will automatically close.
- Pressure gauge: For single-door sterilizer, two pressure gauges are installed at the front door control end, one showing the generator pressure and the other showing the chamber pressure. If it is a double-door sterilizer, it is also equipped with the same pressure gauge at the rear end to indicate the chamber pressure as that at the front end.

5.4 Control system structure principle

The control system consists of main controller, monitor, micro thermal printer, solenoid valve, pressure transmitter, indicator and display meter.

1) Front panel

The front panel is mounted on the upper end of the front cover of the machine and contains the monitor, printer, and key switch.

- Monitor: display screen, features as follows
 - a. Can display graphics, dynamic text
 - b. Full touch operation, simple and convenient
 - c. Excellent communication function
- Printer: Micro power consumption, micro size, panel mounting and high quality printing are the prime features of this printer. Functions: It can record the work start time, running counts, operator number, cycle nature, cycle setting parameters and pressure and temperature values at the same time

during cycle operation. The printing interval can be set by the user.

2) Rear panel

- The rear control is only available for double-door sterilizers, fitted with five indicator lights and one pressure gauge for the chamber, with indicator lights Run (green), Door Close (yellow), Door Lock (yellow), Alarm (red), End (green).

3) Main control box

- Main Controller: Powerful, the main control part of the controller is a highly integrated chip produced in the U.S.A., with reliable performance; logical judgment, floating-point number operation, data storage, communication network and other properties are better than the traditional PLC control. It is general industrial device integrated with microcomputer technology, automation technology and communication technology. It is cost-effective, easy to use, has been extremely applied in the various industrial control. It is based on the pre-input program to work, receive and process a variety of input and output signals, control the sterilization cycle process.

Note: The permissible range of power supply voltage is 24VDC; its working environment is 0°C~55°C.

- The equivalent circuit of this controller consists of four parts:
 - a. Input: it receives operation instructions, or receives various state information of the controlled object; it controls the proceeding and conversion of the program flow.
 - b. Control part: this part is the control program prepared by the user, the control program is placed in the controller's ROM. When the system runs, the controller reads the program storage area sequentially, interprets and executes their contents, and the instructions that need to be output are sent to the output terminals of the controller to control the external load.
 - c. Output: according to the execution of the program directly or through an

intermediate relay to drive the load.

- d. Analog conversion: 5-way analog input, 12-bit conversion accuracy; the input standard current signal into a digital signal, according to the definition of the program is converted into different engineering quantities, in this control, converted to temperature, pressure.



The ground line of the control box must be reliably grounded otherwise there will be a jump in temperature and pressure!

- **Buzzer:** When misoperation occurs, or the sterilization cycle is abnormal, the buzzer will sound an alarm tone for prompting. When the sterilization is completed, the buzzer will also prompt.
- **Indicator Lights:** (Double-door Equipment) There are five indicator lights, from top to bottom, Door Close Light, Door Lock Light, Running Light, Alarm Light, and End Light. When the loading door and unloading door are closed at the same time, the Door Close Light is on, and when the electromagnetic lock of the loading door and unloading door are locked at the same time, the Door Lock Light is on.
- **Fuse holder:** the fuse holder is equipped with a fuse, which is the protector of the control system to prevent excessive current from damaging the electrical components; it is equipped with a cylindrical cap fuse.
- **Vacuum pump contactor:** PLC output signal to the vacuum pump contactor coil, the contactor coil gets power to close, provide three-phase 380V AC power to the pump, the pump starts to run.
- **Pipeline pump relay:** PLC output signal to the pipeline pump relay coil, the relay coil is electrically closed to provide 220V power supply to the pump, the pump begins to run, the pump begins to fill water (if the first time you use and the water source is no pressure or pressure is low, add diversion water in advance).

- Heating tube contactor: PLC output signal to the heating tube contactor coil, the contactor coil get power to close, to provide three-phase 380V AC power to the heating tube, the heating tube get power, start heating.
 - Heating membrane contactor (only for 100L and below): PLC output signal to the heating membrane contactor coil, the contactor coil is energized and closed to provide AV 220V AC power to the heating tube, the heating membrane is energized and starts heating.
- 4) Solenoid valve: the control system output signal to the solenoid valve, so that the solenoid valve coil is energized suction, connected to the solenoid valve at both ends of the pipeline. After the coil is de-energized, the valve is closed.
- 5) Pressure transmitter: the pressure signal of the chamber is transformed into 4-20mA current signal, and then transformed into digital signal by the module, which is embodied in the touch screen as the actual value of the chamber pressure.
- 6) Platinum RTD:
- Working Principle: Within a certain range, the resistance of PT100 is linearly proportional to the temperature. When the temperature rises, the resistance value becomes larger; when the temperature decreases, the resistance value becomes smaller. At room temperature (20°C), the resistance value of PT100 platinum resistance is 107.79 ohms. The thermal resistance value of PT100 is given to the temperature transmitter, and then the temperature transmitter is passed to the analog module after conversion, and then sent to the touch screen to show the actual temperature value.
 - Installation and Use: Platinum RTDs are installed in the lower part of the chamber at the location of the exhaust port, and must not come into contact with the pipe wall or stagnant water. The connecting wires should be securely fixed on the terminals.
- 7) Pressure gauge: Please refer to the pipeline system.

5.5 Working principle of the control system

The control system uses a highly integrated chip as the main control chip, the use of touch-screen display as a human-machine interface, in the control of temperature and pressure signal acquisition with analog standard modules: temperature probe PT100 will be sent to the controller resistance value of the signal can be converted into an acceptable digital quantity; measurement of pressure pressure with the pressure transmitter will be converted into a standard pressure signal 4-20mA current signal, processed into the amount of engineering unit. The advantage of analog control lies in the continuous change of temperature and pressure during the sterilization process, which can be detected by the programmable controller at the right time and displayed on the human-machine interface.

Before working, you must adjust and preset the parameters of each instrument according to the sterilization requirements of the sterilized items, and select the corresponding sterilization program and working mode. Please refer to Chapter 5 “Use and Operation” for specific parameter settings.

1) Power on

Turn on the three-phase gate switch (or circuit breaker) in the power switch box, and then turn on the switch on the front panel of the equipment (key switch), the switch to the “On” position, the switch is closed, the 220VAC power supply through the fuse to the controller in the control box and the standard power supply (for +5V/24VDC) power supply, the standard power supply to the touch screen and printer power supply. The standard power supply supplies the touch panel and printer. When the power supply is turned on, the indicator light of PLC in the control box is on, the indicator light of the standard switching power supply is on, the touch screen displays the initial screen after self-checking, and the printer indicator light is on, and all of them are in standby mode.

2) Door control

Firstly open the power switch, for XG1.UCD Pulsating Vacuum Sterilizer, the door will be closed after rotating the door handwheel, in the door bolts in place and then rotate 1-1.5 turns, the door travel switch closure, to the PC machine back to the input signal, in the front door display shows the door off state, the back door indicator lamps show the door status input are signals, the device enters into standby mode.

The front and rear door switches of the sterilizer are controlled by whether the sterilization cycle is running, the chamber temperature is high or low, and whether there is pressure in the chamber, so as to ensure the safety of the equipment and the operators, and for the double-door sterilizer, it can effectively ensure that the contaminated area is isolated from the sterile area. Standby state or the end of the process, when the front door (back door) is opened, the back door (front door) electromagnetic lock pops open and locks the door to achieve the effect of isolation.

Note: If it is a single-door sterilizer there is no back rear indication.

3) Generator control

The system is powered, after self-test, the main controller is in working condition. If the low water level is not reached for water injection, the water level is reached after heating and then automatically maintain the pressure of the generator in a certain range.

If there is a jacket, the equipment jacket and generator is connected, when the pressure reaches the upper limit of generator pressure, the main heating stops, wait for a period of time when the generator pressure drops to the lower limit of the setting of the main heating and start heating again, and so on for the cycle.

During the cycle operation (non-sterilization stage), if the water level is lower than the high water level for three minutes, the water injection pump (valve) will be turned on for water injection so as to keep the water level in the generator at the upper water level.

4) Chamber steam inlet control

After the key switch is energized, the signals are processed by PLC, and the

inlet valve is switched on and off for control in accordance with the process needs.

5) Chamber vacuum

“Fabric”, “Instruments” and “BD” and other programs, pulsation should be evacuated, so that the chamber close to a vacuum, in order to enhance the penetration of steam. After running the program, the first thing to enter after the preparation is complete is the pulse stage, where the air in the chamber is pumped out by the vacuum pump through the vacuum valve. When the pressure of the chamber reaches the lower limit of pulsation, the vacuum valve F3 closes and the pumping stops. When the pressure of the chamber reaches the upper pulse limit, the valve F0 opens, and when the pressure of the chamber drops to the pumping turning pressure (default 30kPa), the vacuum pumping starts again. This happens again and again until the set number of pulsations is reached. After the end of pulsation, the valve F3 closes and the vacuum pump stops.

6) Chamber steam outlet

- Non-liquid cycle

After the sterilization stage ends, the cycle turns to the steam outlet stage. First, open the chamber valve F0 to start steam exhaust. When the chamber pressure drops to the pumping turning pressure, the pump water valve F7 opens, the valve F3 opens, the vacuum pump starts to run, and the speed of steam exhaust accelerates.

- Liquid cycle

In the liquid cycle, after the sterilization process is over, the valve F5 is opened intermittently, and the chamber steam is discharged slowly through the trap valve, forcing the pressure in the chamber to drop slowly, thus preventing the liquid from over-boiling and overflowing.

7) Drying stage

Due to the different nature of the items, instruments, fabrics, BD, etc., when the drying stage is required in the vacuum cycle, the cycle is transferred to the drying stage when the chamber pressure drops to the zero steam exhaust level. The pump

water valve and vacuum valve are opened, and the vacuum pump runs for vacuum drying. When the drying time arrives, the vacuum valve, pump water valve, vacuum pump stops and the drying process ends.

8)Cycle end

In the fabrics, instruments, BD and other cycles, when the drying time arrives, the air valve F4 opens, the chamber air inlet pipeline is open, start to fill the air, restore the chamber pressure, when the chamber pressure reaches back to the air zero position, the cycle delay turns to the end.

4.6 Outer decorative plate

All external decorative panels of this equipment are routinely sprayed steel (stainless steel can be customized), which is beautiful in appearance and easy to disassemble. In the process of using the equipment, if necessary, you can lift the left and right sides of the outer decorative plate in the middle of the two grips, lift upward to remove the outer decorative side cover.

6 Use and Operation

Firstly, the sterilizer can run normally according to Chapter 3 “Installation and Commissioning”, turn on the power supply and water, turn the key switch of operating side to “ON” side, the system is powered to start the self-test, self-test process text display will appear on the initial screen.

*Special Note: When the control system is abnormal, you can **restart the system by power failure** to determine whether the control system is really abnormal or interference.

1) The device has a perfect user management system with the following features:

- 5-level operating privileges, in line with IEC61010 (safety requirements for electrical equipment for measurement, control and laboratory);
- 32 user accounts, which are automatically linked to the EM operator number of the traceability system;
- User name, password, and even permission levels can be changed, can add, modify and delete users;

2) The user management system is operated as follows:

First, log in according to the guidance in Chapter 5.3.

Log in

- **Lv.1**: Operator(sterilizing staff) ;
- **Lv.2**: Supervisor (QC or Nurse Manager)
- **Lv.3**: Technician (Hospital equipment department or manufacturer's after-sales service personnel);
- **Lv.4**: Engineer (User engineer);

- **Lv.5**: Manufacturer.

Users can change their user names and passwords, and users with higher privileges can edit the user names, passwords, and user privileges of users with lower privileges or delete users.

The user rights and passwords are as follows:

Table 4-1 User Management Screen

Level	Initial password	Primary authority	Remarks
1 Operator (sterilizing staff)	/	Open and close door Start and select cycles View and confirm alarm messages Auxiliary functions include: repeat printing, barcode information, countdown timer, input detection, machine information, door operation items, calculation tools, energy consumption information, user management (only able to modify own account information), language	Normal operation of the machine Account information includes permission level, user name, password, etc.
2 Supervisor (QC or Nurse Manager)	78	In addition to the Operator's authorities, add: Cycle settings (only lower-level cycle parameter settings can be modified) User management in auxiliary functions (in addition to modifying own account, can also modify the account information of all operator authorities, and can also set whether log out automatically during power failure).	Add simple cycle parameters that can be modified

3 Technician (Hospital equipment department or manufacturer's after-sales service personnel);	--	In addition to Supervisor's authorities, add: System settings include: date and time, print settings, alarm management (only lower-level settings can be modified). User management in auxiliary functions (in addition to modifying own accounts, can also modify the account information of all Supervisors and Operators)	Add system settings that can be modified and commonly used
4 Engineer (User engineer);	--	In addition to Engineers authorities, add: System settings include: alarm management (can modify all alarm management settings), network settings, manual operation, record settings, deviation calibration, traceability settings, system parameters. Program settings (can modify all settings of cycle parameters)	Add more complex and advanced system settings and cycle settings
5 Manufacturer	Dynamic Verification Code	In addition to the engineer authorities, add: 1. System settings include: machine configurations	Add the authorization that can affect the underlying configuration of the device security and the functions to be purchased, etc.



Level 1 Operator, Level 2 Supervisor, Level 3 Technician are user

rights. Level 4 Engineer and Level 5 Manufacturer are factory maintenance rights, which will not be disclosed to users.

User management principles:

- 1) All privileged users can modify their account's password and name, but not their account's privilege level;
- 2) Users with higher privileges can modify all passwords, names, privilege levels and other information of all users with lower privileges;
- 3) Only users with higher privileges than the operator can modify the password, name, privilege level and all other information of other people's accounts of the same level;
- 4) When modifying the privilege level of other accounts, the range of privilege level modification is not higher than the privilege level of the currently logged-in personnel.

Note: About the power failure user automatic logout. When the power failure logout mode is turned on, the machine will automatically logout the current user every time the power is turned off, and you need to log in again when the power is turned on again. When user power failure automatic logout is turned off, the machine will not log out the current logged-in user when power failure occurs.

6.1 Operation instructions

- Sterilization process key parameters description:

Sterilization temperature and time are the key parameters affecting the sterilization process. During the sterilization process, the control system controls the sterilization temperature range in the chamber with the lower limit being the set sterilization temperature and the upper limit being the set sterilization temperature +2°C. The default combination of sterilization temperature and time of this control system is shown in the table below. When selecting non-recommended loads, non-recommended packages, or other combinations of sterilization temperatures and

times, it is necessary to go through the relevant sterilization process verification before use.

NOTE: For the same load, package, and sterilization temperature, if a longer sterilization time is considered more effective than a shorter sterilization time, only the shortest sterilization time required may be validated.

Table 6-1 Sterilization process key parameters

SN	Cycle	132°C pulse vacuum cycle	121°C pulse vacuum cycle
1	Temperature	132°C	121°C
2	Time	10min	20min
3	Items applications	Items with high vacuum and high temperature resistance, such as instruments and dressings.	Items with high vacuum and low temperature resistance, such as rubber.

Note: the settings of the cycle parameters, should be amended during the operation process according to the specific circumstances or their own sterilization process, after the completion of the amendments need to be verified qualified, and final biological test should be all qualified before use.

System built-in 32 sets of preset cycles(some cycles need to be equipped with relevant hardware). Details of the equipment cycle configuration are shown in the following table:

Table 3-4 Equipment Cycle Configuration

Cycle Type	Cycle Name	Remarks
Sterilization Cycle	Fabric, instrument, heat-sensitive materials, flash cycle, orthopedics, prion, lumen, heavy loads, small loads, open liquids, gravity cycles, etc.	
Test Cycle	B&D test, leak test, PCD test, A/D test (optional hardware required)	
Auxiliary Cycle	Warm up, drying	

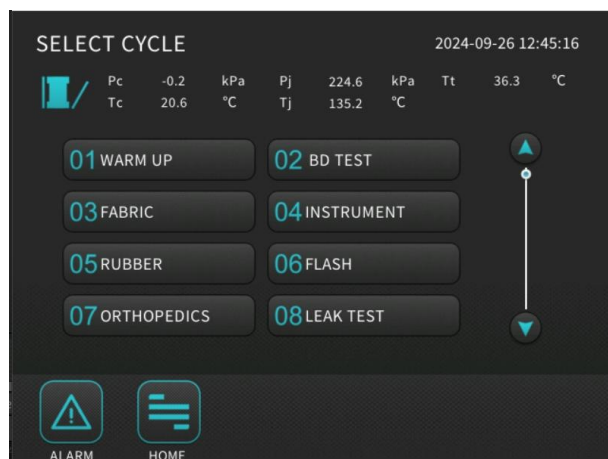

Figure 3-15 Select cycle

Note: In the case of the temperature can not heat up (within 2 °C lower than the sterilization temperature) when running the cycle (especially the flash cycle), you can modify the upper limit of the pressure in the chamber in Figure 8 to increase the pressure (generally increase 10KPa, about 1 °C increase in temperature)

(1) Screen operation:

If the equipment uses the jacket heat preservation mode, the temperature of the chamber wall will no longer be displayed in the operation screen.

After turning on the equipment, log in and then enter the main menu screen.

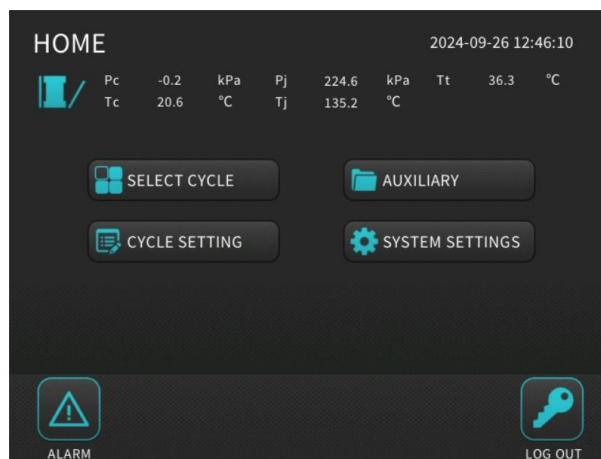

Figure 4-1 Main menu

Run cycle: Click the **Run Cycle** button to enter the **cycle selection** screen, users can select different sterilization cycles according to their needs;

Auxiliary: Click the **Auxiliary** button to enter the auxiliary function screen, where you can use the auxiliary functions such as **Language, User Management,**

Calculation Tools, Machine Information and so on;

Cycle Setting: click the **Cycle Setting** button to enter the **cycle setting** screen, select the corresponding cycle, and the user can edit the parameters;

System Setting: click **System Setting** button, where users can set the system parameters, date and time, network parameters, etc., and perform manual operation, etc.

(2) Select cycle and Start

After logging in, press the **Run Cycle** key in the **main menu** screen to enter the Select Cycle screen.

According to the type of items to be sterilized, select the corresponding sterilization cycle.

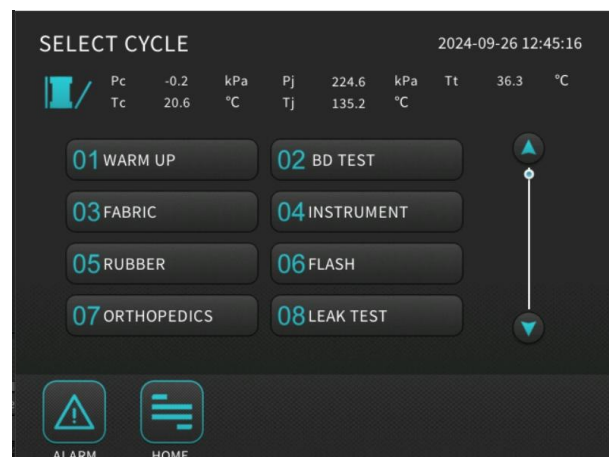

Figure 4-3 Select cycle

(3) If the atmospheric pressure in the user's area is not a standard atmospheric pressure, please contact the engineer to set the relevant parameters and adjust the zero position of exhaust and zero position of air break.

6.2 Parameter settings



Cycle parameter editing must be performed by a trained professional technician.

Sterilization process key parameters description:

Sterilization temperature and sterilization time are the key parameters affecting the sterilization process, sterilization process, the control system to control the sterilization temperature range in the sterilization chamber lower limit for the set sterilization temperature, upper limit for the set sterilization temperature +2 °C.

Note: the setting of the cycle parameters, should be used in accordance with the specific circumstances or their own sterilization process for correction, after the completion of the correction needs to be verified and qualified, and final biological testing should be all qualified before use.



Non-authorized cycles will not be available for use and editing.

Cycle parameter settings require level 2 supervisor or higher privilege users to edit.

After users with level 2 Supervisor or above authority logging in, will enter the following **Select Cycle** screen by pressing the **Cycle Setting** button on the **Main**

Menu screen, and click the  icon to view the contents of the next page.

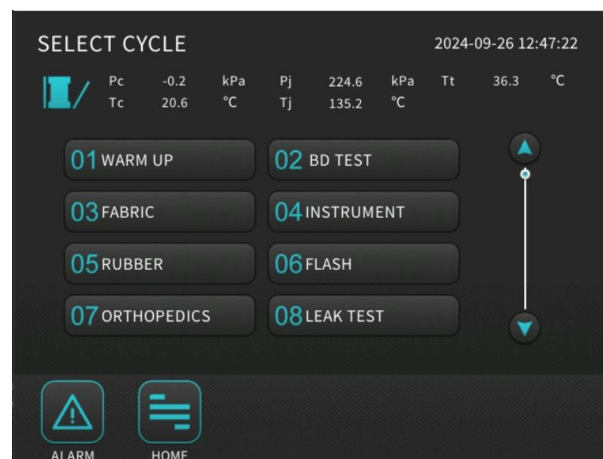

Figure 4-16 Select cycle editing screen

Program Parameter Settings

Select the authorized program on the **Select Cycle** screen to enter the first page of the **Cycle Setting** screen. Supervisor authority can set the primary parameters of the cycle on this screen.

Enter the following parameter setting screen:

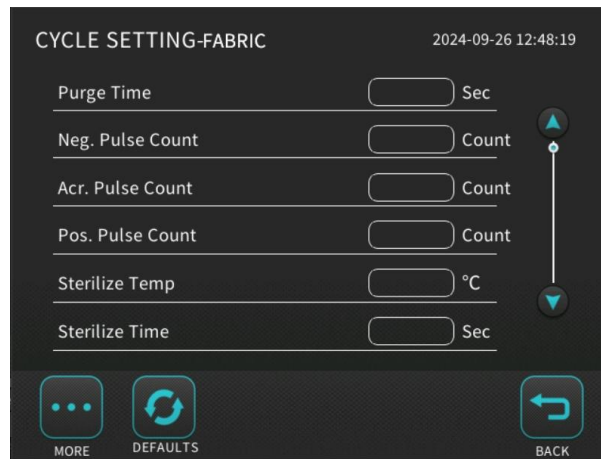

Figure 4-17 Cycle setting

The meanings of the parameters in the are described below:

Purge Time——The air in the sterilization chamber is “replaced” by filling the chamber with steam through circulation and then discharging the steam by its own pressure and gravity. The period at this stage is the purge time. Generally used in P13 open liquid, P14 gravity cycle.

Pulse Count—— the steam inlet system of vacuum system and the sterilization chamber alternating run, the sterilization chamber pressure pumping to the pulse lower limit, and then fill the steam to the pulse upper limit, so the number of times that is the pulse count, generally used for sterilization cycles and test cycles that require pulsation.

Acr. Pulse Count—— the steam inlet system of vacuum system and the sterilization chamber alternating run, the sterilization chamber pressure pumping to the cross-pressure pulse lower limit, and then fill the steam to the cross-pressure pulse upper limit, so that the number of times that is Acr. Pulse Count, generally used for sterilization cycles and test cycles that require cross-pressure pulsation.

Pos.Pulse Count——the steam inlet system of vacuum system and the sterilization chamber alternating run, the sterilization chamber pressure pumping to the positive pressure pulse lower limit, and then fill the steam to the positive pressure pulse upper limit, so that the number of times that is positive pulse count, generally

used for sterilization cycles and test cycles that require positive-pressure pulsation.

Sterilization temperature—— in the sterilization stage, the lowest temperature value of the control chamber temperature T_c is the sterilization temperature.

Sterilization time——in the sterilization stage, the time required to control the chamber temperature T_c to maintain at the sterilization temperature is the sterilization time.

Vacuum drying time——vacuum drying stage, by the vacuum system, the load in the sterilization chamber for continuous vacuum drying, the chamber reaches the vacuum drying pressure, and maintain this vacuum state, this period is the vacuum drying time.

Pulse air drying count——pulse air drying means through the vacuum system and the chamber air inlet system works alternately, the load in the sterilization chamber for drying, so the number of times repeatedly that is the pulse air drying count.

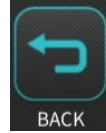

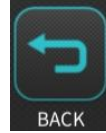
After the modification is completed, click the  button, the program will pop up the following prompt, asking whether to save the parameters:

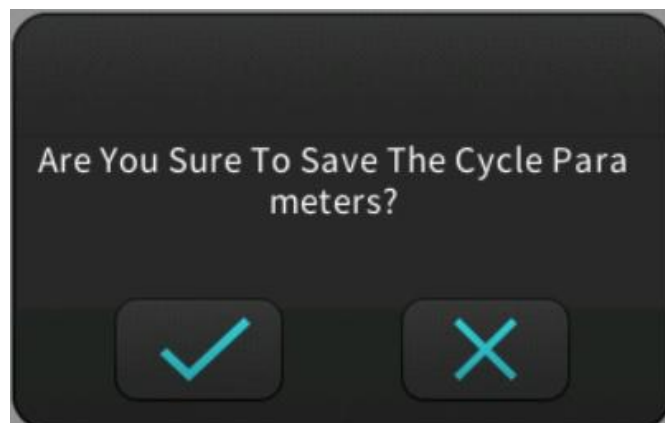



Figure 4-18 Cycle parameter saving prompt pop-up window

If you want to save the changed parameters you need to press the  button, if you don't need to save the parameter changes you need to press the



button.

If you need to restore the cycle parameters to the default parameters, you need

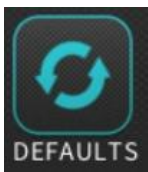

to press the button.



If you want to access the advanced cycle parameter settings, you need level LV4 Engineer or above permission to access them, which will not be described in this Manual due to the sterilization safety of the machine.

2) System parameter settings:

- Air break zero position and exhaust zero position: if the user's local atmospheric pressure is non-standard atmospheric pressure, users should set air break zero position and exhaust zero position, which need to do at the beginning of the commissioning by factory engineer.
- Pulse upper and lower limit: if users need to change it, please consult the after-sales service personnel.
- Time setting: change the time in the system maintenance option, click save to modify the current time of the equipment.

3) Special cycle description: Liquid Cycle

Liquid cycle sterilization load for non-closed liquid items, not be for closed liquids, the default sterilization time for 20 minutes.

Bottle volume (ml)	Sterilization time (minutes)
75	20
250	25
500	30
1000	35

1500	45
2000	45

Purge time——Before the liquid cycle warms up, the chamber enters the steam from the jacket and at the same time discharges the steam from the exhaust port, the purpose of which is to gradually replace the cold air in the chamber.

Sterilization time——for liquid items, should be set according to the amount of liquid contained in the table on the right for reference. The sterilization time listed in the table is the minimum time required at 121 °C disinfection temperature, the use of appropriate corrections should be made according to the specific circumstances, if you need to lower the disinfection temperature, should extend sterilization time accordingly.

Exhaust pressure difference—— the liquid cycle adopts slow exhaust valve in the process to prevent the pressure inside the sterilization chamber drops too quickly and cause excessive boiling of the liquid or placed in the liquid vessel explosion. In order to further rationalize the control of the speed of steam exhaust, the program introduces the parameter exhaust pressure difference, that is, the value of the slow exhaust valve every time you open to unload the pressure in the chamber. If the setting of the exhaust pressure difference of 10kPa, then the slow exhaust valve is opened to wait for the pressure in the chamber to drop 10kPa after closing, the next time to open determined by the parameter exhaust interval.

Exhaust interval——liquid exhaust process, each time the slow exhaust valve closed to the next slow exhaust valve open time interval. Setting this parameter can achieve the purpose of controlling the steam exhaust rate of the chamber by controlling the opening frequency of the slow exhaust valve.

6.3 Manual operation

Users can manually operate the equipment after logging in with processor and administrator privileges, as shown in Fig. 13. Clicking on the automatic button will

switch to the manual operation state, and clicking on each component can switch it on and off. Among them, F0 chamber exhaust valve, F2 chamber charge valve, F3 chamber vacuum valve, F4 vacuum air break valve, F5 internal discharge valve, F6 water injection valve (water injection pump), F7 vacuum pump water valve, F8 generator pressure relief valve (manual ball valve), evaporator heating tube, heating film (with jacket equipment without heating film). Then click the manual button to exit manual operation.

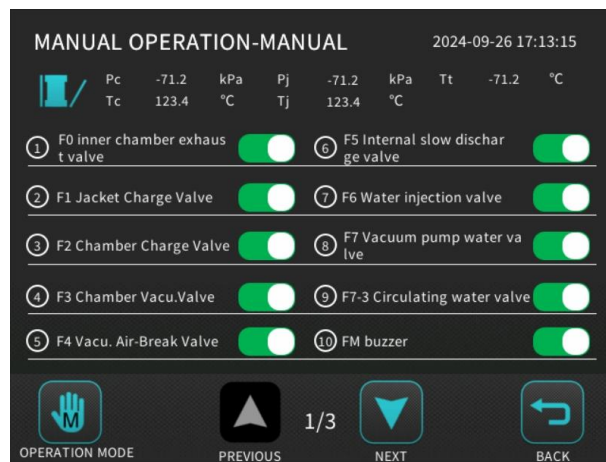

Figure 13

Note: The heating tube, heating membrane and vacuum pump can not be opened for a long time manually, and open the heating tube to ensure that the generator water level is higher than the low water level. The pump should not work too long without water.

6.4 Cycle running

After logging in with different rights to select the start cycle, enter the select cycle screen in Figure 10, select the appropriate cycle, if you need to modify the parameters, click edit to modify the parameters, if there is no need to modify, directly click start, enter the startup parameters screen in Figure 11, and then click on the startup cycle to enter the main process screen in Figure 15.



Figure 15

1) First of all, print the header, enter the preparation stage after header printing finished, non-liquid cycle includes the following stages, in order: “Preparation”, “Pulse”, “Heat up”, “Sterilization”, “Exhaust”, “Drying”, and “End” phases. Liquid cycles include: “Preparation”, “Purge”, “Heat up”, “Sterilization”, “Exhaust”, “End”. stages.

2) In cycle running process, click on the value display button can monitor running count, running time, etc. in real time, in the main process screen displays the pressure and temperature in the sterilization chamber and shows what stage the equipment is currently in Figure 15 (when the cycle is running or has been running through the stage, there are text prompts above the stage, such as preparation).

6.5 Precautions for sterilization operation

- During the cycle running process, the operator please do not move away from the equipment, pay attention to observe the operation of the equipment;
- Manual operation of the cycle process should only be done by operators who have received training on the sterilization equipment.
- If the display does not respond, you can choose to cut off power supply and restart to check the control system for any problems.

Precautions for liquid sterilization:

*** Be careful when sterilizing liquids to avoid accidents such as explosions and burns, and strictly observe the following operations;**

- Liquids can only be non-confined liquids
- Only liquid cycle can sterilize liquids, it is strictly prohibited to open the pump to vacuum after the end of the exhaust, otherwise the bottle will be burst and the liquid will boil.
- After the sterilization is completed, the chamber temperature to 80 °C (can be set) below, the cabinet door will be opened about 10mm gap waiting for about 10 minutes, and then open the cabinet door, take out the liquid bottle.
- When loading or taking out the liquid bottle, it should be held as gently as possible to avoid bumps, vibrations and collisions.

7 Troubleshooting



During operation, you should be alert to every abnormal thing that occurs, such as pipeline leakage of steam and water, compressed gas leakage, cycle is different from usual, etc!

7.1 Common failures and solutions:

1) Alarm List:

Table 7- 1 Alarm List

SN	Alarm	Analysis
Code 33	Chamber Temp. Tc Error;	Check wiring, PT100, etc.
Code 39	Record Temp. Tr Error;	Check wiring, PT100, etc.
Code 41	Chamber Pressure Pc Error;	Check wiring, pressure transmitter, etc.
Code 42	Jacket Pressure Pj Error;	Check wiring, pressure transmitter, etc.
Code 77	Low Water Level In Boiler;	Check water supply pressure to see if water inlet solenoid valve is damaged.
Code 78	Evaporator Water Level Detection Is Faulty;	Check wiring, water level relay, water level probe, etc.
Code 83	Vacuum Pump Overload;	Vacuum pump motor protector overload protection, please reset the motor protector, and check the motor protector protection current,

		water supply, 3-phase power supply, and whether there are foreign objects blocking the vacuum pump.
Code 88	Low Sterilization Temp. In Sterilization , Cycle Aborted;	Check whether the pipelines with water and the PT100 and pressure transmitter are normal.

2) Analysis and solutions of common failures:

Any parts, electrical components have its own inherent service life, failure is difficult to avoid. In order to help operators and maintenance personnel as soon as possible to identify the causes of failure, Table 7-2 Sterilizer Failure and Solutions lists some of the possible failures, possible causes of failure and solutions, solutions for reference.

Table 7-2 Sterilizer Failure and Solutions

Failures	Reasons	Solutions
Display does not light up when power is turned on	Display not powered on	Check text power supply
	Blown fuse	Replace Fuse
	No 24V power supply	Check 24V power supply
Cycle does not start	Cabinet door not closed	Please close the cabinet door
	Alarm not canceled	Check and eliminate the alarm
Display communication failure	Communication interface burned out due to unplugging with electricity	Replace the communication cable to check if the interface is burned out
	Poor contact	Shut down and reconnect
The display shows nothing	Poor contact on communication cable	Check communication and restart
	No 24v power supply	Check 24V power supply

Pump pumping too slow, negative pressure can not reach the standard	Leak in vacuum line	Check the pipeline connection parts, carry out the LeakTest
	Improperly adjusted flow ball valve	Adjust ball valve opening
	No water or low water pressure	Check for water supply
	Pressure transmitter failure	Check or replace pressure transmitter
	Chamber trap line check valve damaged	Repair or replace check valve
	Condensate in piping system	Check valves and piping and clean as necessary
	Evacuation valve or pump not turned on	Check solenoid valves or pumps
	Excessive scaling in lines	Chemically descale piping systems such as condensers and pumps
	Highlands Problems	Plateau for inconsistencies between absolute and relative pressures, see Table III: Pressure Calibration Chart
Vacuum pump noise	Water supply not connected;	Check the water supply;
	Pump inlet ball valve angled too far	Adjust the ball valve opening angle;
	Vacuum pump is heavily scaled	Descaling pumps and lines

	Circulating water pressure too high	Adjust ball valve angle
Vacuum pump does not start	No power supply	Checking the power supply to the vacuum pump
	Vacuum pump damaged	Replace the vacuum pump
Solenoid valve does not run	Coil faulty	Check solenoid valve coil
	Loose wiring	Check solenoid wiring
Jacket pressure is high, but the chamber pressure not go up or F2 can not be opened	Jacket trap opened too wide	Adjust trap
	There are leaks in the piping	Check steam leaks
	Chamber pressure limit set too low	Set chamber pressure limit
	Solenoid valve Damaged	Check solenoid valve
	Loose wiring	Check solenoid wiring
Heating up too slow	Slow main heating	Check main heating
	Low pulse count or short purge time	Increase pulse count or extend purge time
Pressure reached, but the temperature does not rise	Trap opening is too small, causing water to accumulate in the trap line;	Adjust trap opening frequency
	Too few pulse count	Increase the pulse count(default three)
	Slightly lower pressure in the chamber	Increase inner chamber pressure limit according to actual temperature

Temperature display is 0 or 200	Platinum RTD not properly connected.	Check platinum RTD and rewire
Pressure does not show -100	Pressure transmitter is not properly connected	Rewire
Temperature and pressure jump	The ground wire is not connected;	Ground wire re-grounded;
	There is a strong magnetic field around the device;	Check the source of the surrounding magnetic field;
Temperature and pressure do not match	Correction of the temperature	Calibration of inner chamber temperature
Generator water level detection error	Incorrect wiring of the water level float (probe).	Re-check wiring by electrician
	Water level float (probe) damaged	Checking and replacing floats (probes)
Low temperature alarm	Clogged inlet valve or leaking exhaust valve	Cleaning and checking solenoid valves
	Cold air is not being discharged cleanly	Turn up the upper pressure limit of the inner chamber
Generator water filling timeout	Insufficient water in tank	Fill water reservoir and retry
	Water inlet filter clogged	Check evaporator water inlet filter element
	Generator water level sensor failure	Replace the water level sensor
	Check water injection pump (if available)	Add pilot water or overhaul and replace the water injection pump

Chamber overpressure		Pressure sensor in chamber failure	Have an electrician check the circuit and replace the pressure sensor
		Low PT100 temperature collection in chamber	Contact the supplier to correct the deviation
		Solenoid valve won't seal	Clean filter and solenoid valve
Chamber sensor failure		Chamber PT100 sensor disconnected	Have an electrician check the circuit and re-crimp the sensor wires in the chamber.
		Chamber PT100 temperature failure	Check PT100 in chamber
Sterilizer chamber over temperature		Inlet solenoid valve not sealing	Clean solenoid valve
		PT100 temperature failure in chamber	Check the PT100 in the chamber
Indicator light on rear door panel does not light up		Loose wiring;	Loose wiring;
		Bulb burnt out or fuse broken;	Replace bulb or fuse;
Front and rear door display pressure does not match		Pressure gauge display inaccurate	Calibrate pressure gauge
		Pressure gauge is damaged	Replacing the pressure gauge
Possible malfunctions of the steam generator:	No power	Power cord not connected	Secure the power cord
		Control switch damaged	Replacing the control switch
	No Water	Water level electrode failure	Repairing

		Water inlet solenoid valve does not work	Repair
		Water pump damaged	Replace
		Water level relay damaged	Replacement
	Keep filling water	Water level detection failure	Repair
		Water inlet solenoid valve does not close tightly	Repair
		Water level relay failure	Replacement
		Generator water filling manual open position	Convert manual switch to automatic
	No heating	Water level electrode broken circuit	Repair
		Pressure transmitter contact damaged	Replacement
		Heater damaged	Replacement
		AC Contactor Coil no power	Check the control circuit
		Water level relay damaged	Replacement
	Pressure cannot be controlled, safety valve open	Safety valve not calibrated correctly	Recalibrate
		Pressure transmitter damaged	Replacement
		Pressure gauge failure	Replacement

In short, the failures are different, but no matter what failures occur, to analyze

the possible causes of the failure based on the failure phenomenon and the piping and circuitry involved, and then eliminated one by one, and finally find out the real point of failure to overhaul. Of course, if you do not know the working principle of the equipment as well as the use of the components and installation location will not be able to start, the maintenance should also understand the structural principle of the various components, electrical components.

7.2 Analysis and elimination of wet packages:



The weight of the dressing package after sterilization is 3% higher than before sterilization, this phenomenon is called the wet package phenomenon.

- Loading : whether the loading is too large so that some packages touch the wall inside the sterilization chamber, condensation seeps into the package. Check whether there is any water storage vessel in the package, so that the condensate can not be drained off during the sterilization process.
- Drainage pipe is not smooth: check whether the drainage pipe has too many corners, discharged from low to high, and whether there are impurities in the pipeline clogging.
- Chamber trap line check valve is damaged: this performance for the parcel outside the wet inside dry, is in the drying process of the drainage pipeline in the water back to the chamber.
- Drying time is too short: appropriate increase in drying time to observe the drying effect has not improved.
- Negative pressure does not reach the standard: refer to the “sterilizer failure and troubleshooting table” to check.
- Local wet pack should be analyzed according to the specific location of the wet pack to analyze the causes and comprehensive troubleshooting.

7.3 Analysis and troubleshooting on sterilization failure:



The three main elements of sterilization: saturated steam, sterilization temperature, time.

- Cleaning of items: check whether each cleaning process is operated in strict accordance with the workflow of the supply room to ensure the quality of cleaning.
- Packaging of items: whether the packaging is too large, too tight, whether the packaging material is breathable and other factors will affect the exclusion of cold air and steam penetration.
- Loading principles: whether the loading is placed according to the regulations, whether it is too tight, the amount is too large and affects the smooth flow of steam.
- Cold air residue: the amount of cold air exclusion determines the effect of sterilization, so the focus should be on checking the performance of sterilization equipment is normal. First test paper with B-D test, if there is a problem, then the pressure test or use manual operation of the inner chamber into the steam to check the piping and other places there is no leakage.
- Sterilization temperature: use the stay thermometer to check whether the actual temperature inside the bag reaches the sterilization temperature, whether it matches with the display temperature, check whether the pressure and temperature of the inner chamber correspond to each other, and increase the pressure of the inner chamber appropriately to observe the results of any improvement.
- Sterilization time: whether the sterilization time is set reasonably, whether the chamber steam inlet is too fast, whether the penetration time is not enough, appropriate extension of time to observe whether the results have

improved.

- Failure of sterilization equipment: refer to the “sterilizer failure and troubleshooting table” for systematic troubleshooting of the equipment.
- Improper testing methods, repeated testing or using other lot numbers of reagents.

7.4 Unsolvable problems:

After careful analysis and troubleshooting, you may still encounter some problems that cannot be solved by thorough analysis, at this time you need to make preparations in the following order:

- Record the model number of the problematic equipment and the cabinet number below the front of the chamber.
- e.g. XG1.UCD-135M 20106447
- Recall what was unusual about the operation of the equipment before the failure, what exactly happened after the failure, what checks and adjustments you have made, try to analyze the possible causes, the parts that may have been damaged, and record them.
- Contact the area office or the company's after-sales service department and tell us what you know. We will give you technical guidance or arrange personnel to go for maintenance according to the situation you reflect.

8 Maintenance

8.1 Safety precautions

The following safety precautions must be read carefully when operating and maintaining this equipment.



- Burn hazard: If the ambient temperature is above 30°C, the surface temperature of the sterilization chamber door may be very high (>70°C).
- Burn and electric shock hazard: Repairs or adjustments must be carried out by trained and specialized personnel. Use of this equipment by untrained or unauthorized personnel or installation of unauthorized parts will cause damage to personnel and equipment.
- When observing the label  (HIGH VOLTAGE), the main switch must be turned off before opening.
- Burn hazard: make the sterilizer, generator (if equipped) and other accessories to cool to room temperature before performing any cleaning or maintenance procedures.
- Do not use the sterilizer to dispose flammable liquids or to sterilize liquids enclosed in glass bottles or glassware.
- Burn hazard: The sterilizer and sterilizing carts/shelves will be hot after the cycle process. Wear protective gloves and coveralls when removing loaded items (wear mask when handling liquids).
- Drop hazard: In the unloading area of the sterilizer, items should be protected from dropping. Sterile packages dropped on the floor or misplaced in an unclean place should be considered contaminated.

- Explosion hazard: This sterilizer is not intended for use with any flammable liquids.
- Burn hazard: When sterilizing liquids, the following must be observed to avoid personal injury or property damage caused by bottle explosions and boiling hot liquids:
 - 1) Use only the Liquid Cycle for liquids; no other cycles are permitted for liquids;
 - 2) Use only vented covers, no airtight screw caps or rubber stoppers;
 - 3) Use only borosilicate glass bottles--do not use plain bottles or bottles that cannot be used for sterilization;
 - 4) Avoid opening the door immediately at the end of the procedure. Wait 10 minutes or more after the end of the liquid program before opening the door and unloading the sterilized items;
 - 5) Slowly take out the cart and do not bump the hot bottles as this may cause an explosion of the hot bottles! Do not move the bottles if they appear to be boiling or bubbling;
 - 6) Move bottles from the sterilizer rack to the storage area only after they have cooled to the point where they can be touched.
- Burn hazard: Failure of the steam supply can cause the sterilization chamber to fill with very hot water. If the auto-complete cycle fails, wait until the cycle has finished processing automatically before opening the door. Do not open the sterilization chamber door if water is leaking through the door gasket.
- Sterility assurance hazard: The sterility of the load will not be assured if there is a failure of chemical monitoring, biomonitors, B&D test, etc. If these problems occur, contact a service professional for repairs.
- Sterility assurance risks: Flash sterilization cycle should not be used as a routine sterilization cycle for items, used in emergencies, only for

sterilization of bare instruments, cycles may not include a drying phase, avoid contamination in transportation, used within 4h, not stored.



Operators or maintenance personnel should turn off the sterilizer switch before entering the sterilization room and retain the key to the sterilization room to prevent the cabinet door from being closed and endangering human life!

8.2 Maintenance Plan

Even if the equipment is operating normally and no malfunctions have occurred, it should be serviced when it has been in operation for a certain period of time. Failure is not only related to the service life and inherent quality of the parts, but also with the use of the correct method or not, as well as routine maintenance has a great relationship. Many failures are due to improper use, operation errors and do not pay attention to routine maintenance and regular maintenance and triggered.

The correct use of sterilization equipment and routine maintenance is to extend the service life of the equipment and reduce the failure of the necessary conditions. Incorrect maintenance will shorten the service life of the equipment.

The maintenance frequency in the following table is the minimum requirement, and should be increased according to the frequency of use and the use of the environment appropriate maintenance frequency.

Table 8-1 Common Maintenance Item List 1(in order of importance)

SN	Importance	Type	Item	Operator	Min. frequency
1	Very important	Safety	Check pressure vessels	Technician	Compliance with regulatory requirements
2	Very	Safety	Calibrate safety valves and pressure gauges	Technician	Compliance

	important				with regulatory requirements
3	Very important	Safety	Check whether the fire wire, ground wire and zero wire at the main power supply of the equipment are fastened	Technician	Each quarter
4	Very important	Safety	Check the heating tube, vacuum pump and other strong electrical parts of the wiring and terminal protection sleeve	Technician	Each quarter
5	Very important	Safety	Generator water level probe (or float) and liquid level meter cylinder cleaning and descaling (built-in generator equipment)	Technician	Each quarter
6	Very important	Safety	Check the dry burning protection device (built-in generator equipment, if available)	Technician	Each six months
7	Very important	Safety	Check safety valve for water or steam leaks	Technician	Each six months
8	Very important	Safety	Check for water leakage from heating tubes (built-in generator equipment)	Technician	Each six months
9	Very important	Safety	Check all electrical cords of the appliance	Technician	Each six months
10	Very important	Safety	Check door safety, including all door position switches, obstruction protection and hinge moving parts	Technician	Each six months
11	Very important	Safety	Check that upper and lower limits of generator pressure are within specified limits (built-in generator units)	Technician	Each six months
12	Very important	Safety	Check that the warning labels on the equipment are complete and that the diagrams are clear and easy to read	Technician	Each year
13	Very important	Safety	Check that the Operating Guide for the equipment are complete	Technician	Each year
14	Very important	Safety	Check pressure safety interlocks	Technician	Each year
15	Very important	Safety	Check front and rear door emergency stop switches (if available)	Technician	Each year
16	Very	Safety	Make sure that all signal wires are not pinched	Technician	Each year

	important		when opening and closing the door		
17	Very important	Safety	Confirm that all spare parts in the maintenance room are not affected by water steam.	Technician	Each year
18	Very important	Safety	Confirm that wireways and terminal guards are complete and no electrical shock hazards	Technician	Each year
19	Very important	Safety	Check grounding impedance	Technician	Each year
20	Very important	Safety	Check low level switch for effectiveness	Technician	Each year
21	Very important	Safety	Replace generator heater tube contactor (built-in generator units)	Technician	Each four years
22	Important	Performance	Check chamber temperature and chamber pressure correspondence	Technician	Each day
23	Important	Performance	Check all pipeline for leaks	Operator	Each day
24	Important	Performance	Leak test	Operator	Each week
25	Important	Performance	Check that the energy supply meets the requirements of the Manual	Technician	Each week
26	Important	Performance	Clean all filters on pipelines	Technician	Each month
27	Important	Performance	Generator boiler and heating tube cleaning (built-in generator equipment)	Technician	Each quarter
28	Important	Performance	Check whether the generator liquid level display glass tube shows correctly, and check whether the liquid level gauge gasket leaks (built-in generator equipment)	Technician	Each quarter
29	Important	Performance	Dusting of electrical components inside the electrical box and equipment valve sensors, etc.	Technician	Each quarter
30	Important	Performance	Clean all traps (if available) on equipment and steam pipelines.	Technician	Each six months
31	Important	Performance	Check and tighten check valves	Technician	Each six months
32	Important	Performance	Lubricate and inspect door moving parts	Technician	Each six months
33	Important	Performance	Check and descale pressure transmitter connections	Technician	Each six months
34	Important	Performance	Check and clean working fluid inlets and cavitation protection ports of vacuum pumps, check pump	Technician	Each six months

			suction and run without leaks		
35	Important	Performance	Check recent alarm logs for causes and assess whether they are due to component failure	Technician	Each six months
36	Important	Performance	Check PT100s for leaks, breaks, knocks and wiring problems	Technician	Each six months
37	Important	Performance	Check the pressure transmitter for leaks, breaks, knocks and wiring problems.	Technician	Each six months
38	Important	Performance	Check the temperature of the chamber and record the temperature difference	Technician	Each six months
39	Important	Performance	Periodically clean all water tanks (if available)	Technician	Each six months
40	Important	Performance	Check equipment drainage pipeline	Technician	Each six months
41	Important	Performance	Vacuum pump cleaning and descaling (if available)	Technician	Each six months
42	Important	Performance	Check the integrity of the insulation of the equipment and external pipeline	Technician	Each year
43	Important	Performance	Check front and rear door rails level and tighten, clean rails (if available)	Technician	Each year
44	Important	Performance	Check and clean steam barriers	Technician	Each year
45	Important	Performance	Check and clean all flow restriction joints (if available)	Technician	Each year
46	Important	Performance	Check vacuum pump shock pads are intact and stable	Technician	Each year
47	Important	Performance	Check all valves for leaks	Technician	Each year
48	Important	Performance	Check key switch for good contact	Technician	Each year
49	Important	Performance	Calibrate equipment date and time	Technician	Each year
50	Important	Performance	Replace door gasket	Technician	Each year
51	Important	Performance	Check temperature, pressure and time parameters with temperature and pressure tester	Technician	Each year
52	Important	Performance	Replace generator water level gauge gasket (built-in generator units)	Technician	Each year
53	Important	Performance	Replace all clamp gaskets on pipelines	Technician	Each year
54	Important	Performance	Replace air filter element	Technician	Each year
55	Important	Performance	Remove and clean bolts	Technician	Each year
56	Important	Performance	Replace PLC battery	Technician	Each two

					years
57	Important	Performance	Vacuum Pump maintenance	Technician	Each two years
58	General	Common	Clean sterilizer chambers, rails and filters	Operator	Each day
59	General	Common	Clean shelves	Operator	Each day
60	General	Common	Clean equipment surfaces	Operator	Each day
61	General	Common	Check equipment printout logs or monitoring data	Operator	Each day
62	General	Common	Drain generator (built-in generator units)	Operator	Each day
63	General	Common	Check and clean door gasket and door seal grooves	Operator	Each week
64	General	Common	Check shelves push-pull, smooth docking, loose bolts (if available)	Operator	Each month
65	General	Common	Check printers	Operator	Each month
66	General	Common	Check and clean equipment panels and maintenance space	Operator	Each month
67	General	Common	Clean printer thermal printer head	Operator	Each year
68	General	Common	Check the integrity of the equipment nameplate	Operator	Each year

Table 8-2 Common Maintenance Item List 2(in order of frequency,the same as 8-1)

SN	Importance	Type	Item	Operator	Min. frequency
1	Very important	Safety	Check pressure vessels	Technician	Compliance with regulatory requirements
2	Very important	Safety	Calibrate safety valves and pressure gauges	Technician	Compliance with regulatory requirements
3	Important	Performance	Check chamber temperature and chamber pressure correspondence	Technician	Each day
4	Important	Performance	Check all pipeline for leaks	Operator	Each day
5	General	Common	Clean sterilizer chambers, rails and filters	Operator	Each day
6	General	Common	Clean shelves	Operator	Each day
7	General	Common	Clean equipment surfaces	Operator	Each day
8	General	Common	Check equipment printout logs or monitoring data	Operator	Each day
9	General	Common	Drain generator (built-in generator units)	Operator	Each day

10	Important	Performance	Leak test	Operator	Each week
11	Important	Performance	Check that the energy supply meets the requirements of the Manual	Technician	Each week
12	General	Common	Check and clean door gasket and door seal grooves	Operator	Each week
13	Important	Performance	Clean all filters on pipelines	Technician	Each month
14	General	Common	Check shelves push-pull, smooth docking, loose bolts (if available)	Operator	Each month
15	General	Common	Check printers	Operator	Each month
16	General	Common	Check and clean equipment panels and maintenance space	Operator	Each month
17	Very important	Safety	Check the heating tube, vacuum pump and other strong electrical parts of the wiring and terminal protection sleeve	Technician	Each quarter
18	Very important	Safety	Generator water level probe (or float) and liquid level meter cylinder cleaning and descaling (built-in generator equipment)	Technician	Each quarter
19	Very important	Safety	Check the heating tube, vacuum pump and other strong electrical parts of the wiring and terminal protection sleeve	Technician	Each quarter
20	Important	Performance	Generator boiler and heating tube cleaning (built-in generator equipment)	Technician	Each quarter
21	Important	Performance	Check whether the generator liquid level display glass tube shows correctly, and check whether the liquid level gauge gasket leaks (built-in generator equipment)	Technician	Each quarter
22	Important	Performance	Dusting of electrical components inside the electrical box and equipment valve sensors, etc.	Technician	Each quarter
23	Very important	Safety	Check the dry burning protection device (built-in generator equipment, if available)	Technician	Each six months
24	Very important	Safety	Check safety valve for water or steam leaks	Technician	Each six months
25	Very important	Safety	Check for water leakage from heating tubes (built-in generator equipment)	Technician	Each six months
26	Very important	Safety	Check all electrical cords of the appliance	Technician	Each six months

27	Very important	Safety	Check door safety, including all door position switches, obstruction protection and hinge moving parts	Technician	Each six months
28	Very important	Safety	Check that upper and lower limits of generator pressure are within specified limits (built-in generator units)	Technician	Each six months
29	Important	Performance	Clean all traps (if available) on equipment and steam pipelines.	Technician	Each six months
30	Important	Performance	Check and tighten check valves	Technician	Each six months
31	Important	Performance	Lubricate and inspect door moving parts	Technician	Each six months
32	Important	Performance	Check and descale pressure transmitter connections	Technician	Each six months
33	Important	Performance	Check and clean working fluid inlets and cavitation protection ports of vacuum pumps, check pump suction and run without leaks	Technician	Each six months
34	Important	Performance	Check recent alarm logs for causes and assess whether they are due to component failure	Technician	Each six months
35	Important	Performance	Check PT100s for leaks, breaks, knocks and wiring problems	Technician	Each six months
36	Important	Performance	Check the pressure transmitter for leaks, breaks, knocks and wiring problems.	Technician	Each six months
37	Important	Performance	Check the temperature of the chamber and record the temperature difference	Technician	Each six months
38	Important	Performance	Periodically clean all water tanks (if available)	Technician	Each six months
39	Important	Performance	Check equipment drainage pipeline	Technician	Each six months
40	Important	Performance	Vacuum pump cleaning and descaling (if available)	Technician	Each six months
41	Very important	Safety	Check that the warning labels on the equipment are complete and that the diagrams are clear and easy to read	Technician	Each year
42	Very important	Safety	Check that the Operating Guide for the equipment are complete	Technician	Each year

43	Very important	Safety	Check pressure safety interlocks	Technician	Each year
44	Very important	Safety	Check front and rear door emergency stop switches (if available)	Technician	Each year
45	Very important	Safety	Make sure that all signal wires are not pinched when opening and closing the door	Technician	Each year
46	Very important	Safety	Confirm that all spare parts in the maintenance room are not affected by water steam.	Technician	Each year
47	Very important	Safety	Confirm that wireways and terminal guards are complete and no electrical shock hazards	Technician	Each year
48	Very important	Safety	Check grounding impedance	Technician	Each year
49	Very important	Safety	Check low level switch for effectiveness	Technician	Each year
50	Important	Performance	Check front and rear door rails level and tighten, clean rails (if available)	Technician	Each year
51	Important	Performance	Check and clean steam barriers	Technician	Each year
52	Important	Performance	Check and clean all flow restriction joints (if available)	Technician	Each year
53	Important	Performance	Check vacuum pump shock pads are intact and stable	Technician	Each year
54	Important	Performance	Check all valves for leaks	Technician	Each year
55	Important	Performance	Check key switch for good contact	Technician	Each year
56	Important	Performance	Calibrate equipment date and time	Technician	Each year
57	Important	Performance	Replace door gasket	Technician	Each year
58	Important	Performance	Check temperature, pressure and time parameters with temperature and pressure tester	Technician	Each year
59	Important	Performance	Replace generator water level gauge gasket (built-in generator units)	Technician	Each year
60	Important	Performance	Replace all clamp gaskets on pipelines	Technician	Each year
61	Important	Performance	Replace air filter element	Technician	Each year
62	Important	Performance	Remove and clean bolts	Technician	Each year
63	Important	Performance	Check front and rear door rails level and tighten, clean rails (if available)	Technician	Each year
64	General	Common	Clean printer thermal printer head	Operator	Each year

65	General	Common	Check the integrity of the equipment nameplate	Operator	Each year
66	Important	Performance	Replace PLC battery	Technician	Each two years
67	Important	Performance	Vacuum Pump maintenance	Technician	Each two years
68	Very important	Safety	Replace generator heater tube contactor (built-in generator units)	Technician	Each four years
<p>Note 1: Operators refer to hospital sterilizers, and technicians refer to maintenance personnel of the hospital equipment department or manufacturers' after-sales service personnel.</p> <p>Note 2: The corresponding operation methods of the above maintenance items are described in detail in chapters 7.3.1-7.3.69 of the manual.</p>					

8.3 Maintenance guidelines

8.3.1 Inspection on the pressure vessel

The product belongs to special equipment and should be registered for use, maintained and regularly inspected in accordance with the requirements of special equipment regulations.

8.3.2 Calibration on safety valves and pressure gauges

The product belongs to special equipment, should be in accordance with the requirements of special equipment regulations for regular calibration of safety valves and pressure gauges and other safety accessories.

8.3.3 Check the correspondence between chamber temperature and chamber pressure

Check the printout records (or monitoring data) of the sterilization process, and its physical parameters should meet the following requirements:

- 1) The lower limit of the sterilization temperature range is the sterilization temperature, and the upper limit should not exceed the sterilization temperature +3°C.

2) Pressure steam sterilizer sterilization physical parameters should meet the requirements of the following table:

Cycle type	Items type	Sterilization temperature setting	Min. sterilization time	Pressure reference range
Liquid	Open Liquid	121°C	30min	102.8-122.9kPa
Gravity	Dressings		30min	
	Instrument		20min	
Pre-vacuum	Instrument	121°C	20min	102.8-122.9kPa
	s, dressings	132°C	4min	184.4-210.7kPa
		134°C		201.7-229.3kPa

8.3.4 Check all pipes for leakage

Observe all pipeline connections with a flashlight, tighten all leaks, and replace gaskets if still leaking.

8.3.5 Clean the sterilizer chamber, rails and filters

- 1) Disconnect the sterilizer from the power supply before cleaning.
- 2) When the temperature of the chamber is reduced to room temperature, wet a clean cotton cloth with pure water and wipe the chamber and guide rail of the sterilizer, use copper water to enhance the effect of decontamination if necessary, and strictly prohibit the use of rust removers and other acidic detergents.
- 3) Clean the bottom filter.

8.3.6 Clean the shelves

Wet a clean cotton cloth with pure water and wipe the sterilizer cart, use copper

water to enhance the decontamination effect if necessary, and strictly prohibit the use of acidic cleaners such as rust remover.

8.3.7 Clean the equipment surface

Use a clean cotton cloth to wipe the surface of the equipment and the display, stainless steel decorative cover can be used stainless steel brightener to scrub, do not use rust remover and other acidic detergent.

8.3.8 Check the equipment print records or monitoring data

Check each cycle phase and data integrity. (Only for equipment with monitoring computer)

8.3.9 Generator drainage(built-in generator equipment)

- 1) Turn off the power;
- 2) Wait for the pressure gauge to drop to approx. 10 kPa ;
- 3) Slowly open the drain valve to drain the water from the steam generator;



Steam release is hazardous and can cause burns; and the noise generated can also cause hearing damage.

- 4) When emptying is complete, close the valve;
- 5) If necessary, perform a repeat draining operation to completely remove the dirt.

Note: The frequency of draining can be adjusted appropriately according to the water quality.

8.3.10 Leak test

Run the leak test cycle, the cycle ends successfully and the leakage rate is not greater than 0.13 KPa/min.

8.3.11 Check whether the energy supply meets the Manual requirements

1) Water supply requirements

- Pressure: 0.15~0.3MPa, up and down fluctuation not more than 10%.
- Temperature: 5 ~ 20°C, too high water temperature will affect the vacuum performance of the equipment.
- Water quality: cooling water: tap water or softened water, hardness less than 2mmol/L.
- Water for generator(for electric heating equipment): pure water, conductivity $\leq 5 \mu\text{S/cm}$.

2) Steam source requirement (applicable to external steam equipment only)

Pressure: 0.3 to 0.5 MPa, up and down fluctuations of no more than 10%.

3) Compressed air source requirement

Pressure: Compressed air source pressure 0.5~0.7MPa entering the equipment.

Cleanliness: the compressed air should be de-watered, de-oiled, colorless and odorless.

4) Power supply requirements

Power supply: AC 380V \pm 38V, 50Hz \pm 1Hz;

8.3.12 Check and clean the door gasket and door sealing groove

Remove the gasket and carefully clean the sealing groove with water, then dry it with a clean cotton cloth or gauze; gently scrub the gasket with water, dry it and put it back into the sealing groove.

8.3.13 Clean all filters on the pipeline

Equipment needs to consume a lot of water and steam in the process of long-time operation, and the pipeline, water and steam sources more or less always have impurities, the filter is to filter these impurities to ensure the normal use of the equipment, so the filter needs to be cleaned regularly to ensure the normal operation of the equipment, the cleaning method is as follows:

- 1) As shown in the figure below, disassemble the filter and take out the filter mesh.



- 2) As shown in the figure below, put the filter mesh in clean water for rinsing, visually inspect the surface of the filter mesh without the presence of particles of dirt, put the filter mesh into the filter after cleaning, reinstall it and check whether the filter is intact.





Filter disassembly and cleaning should be carried out when the equipment cycle stops running, waiting for the chamber and jacket steam to be completely discharged and cooled down to room temperature, otherwise it will cause burns to the operator!

8.3.14 Check the shelf push-pulling, whether the docking is smooth, whether the bolts are loose (if available)

Push and pull the shelf manually to check whether blocked, check whether the bolts loose, if necessary, to adjust and tighten.

8.3.15 Check and clean the maintenance space

Clean sewage and debris from the equipment maintenance space and keep it clean.

8.3.16 Check printer



Two fixing points for the paper slot, used to fix the paper slot.

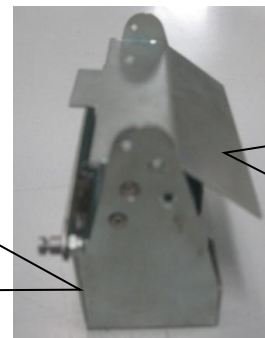

Paper folding stopper

Gently press the lower right corner of the window door, the window door pops open; if you want to take out the hanging paper slot, please press the folding paper stopper by hand firstly, and then lift the hanging paper slot upward and take it out.

The appearance of the printer to store the folded paper slot after printing press the stopper

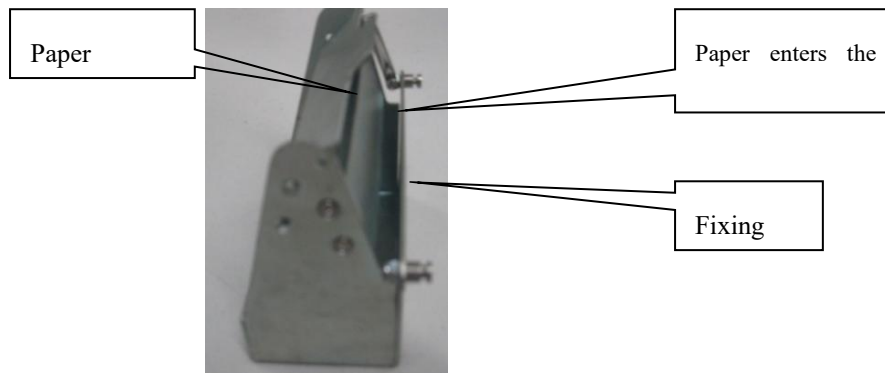

Note: Folded paper should enter the folding slot between the stopper and the fixed plate.

Press the lower right corner of the printer window door or the upper right corner, when you hear the faint sound of the switch closed to let go, the window door can be popped open, this printer uses a folded paper printing, after printing the paper is automatically folded and stored in the paper slot.

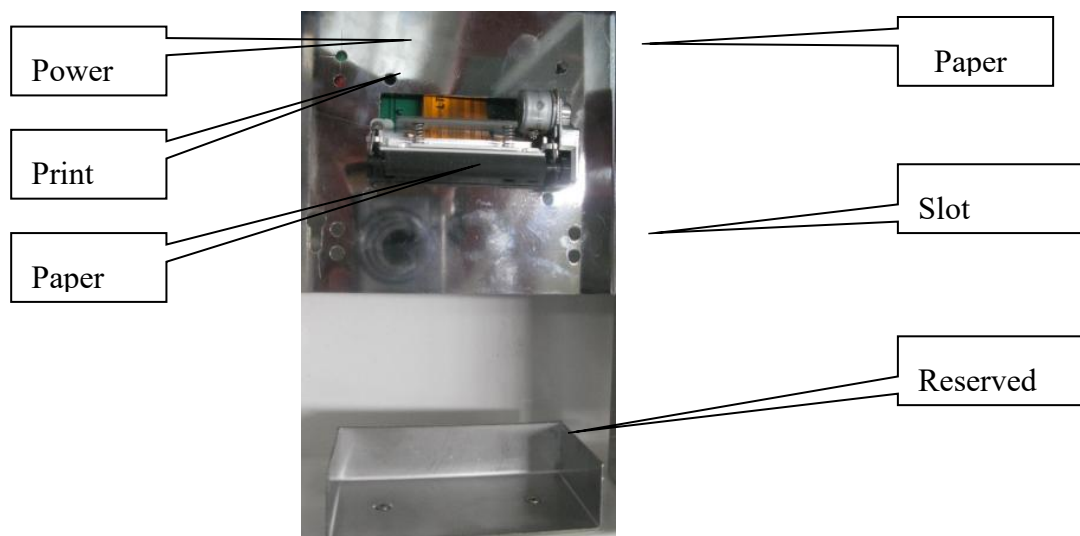

Open the printer window to take down the paper slot appearance

After opening the printer window door as shown in the figure shows that the upper left corner of the green light is the power indicator, the lower part of the red print indicator, the upper right corner of the paper button (press when the print paper will quickly go paper); when the printer is working the red indicator light, when replacing the print paper, first of all, the hanging paper slot removed, and then the print paper inserted horizontally into the paper slot, hold down the upper right corner of the paper button (power) turn on) the folded paper will automatically walk in and hang the paper slot where the recording paper is stored.

8.3.17 Check whether the fire wire, ground wire and zero wire are tight at the total power supply of the device

Check whether the wires are loose at the main power supply of the equipment after the equipment is powered off, and confirm whether they are tight.

8.3.18 Check the wiring and terminal protection sleeve of the heating tube, vacuum pump and other strong electric parts

Check whether the wiring is detached or in contact with the high temperature pipe, and check whether the terminal protection sleeve is softened, carbonized, charred and yellowed.

Tighten the wiring of heating tube, vacuum pumps and other strong electric parts. Motor protectors and contactors should be tightened with screwdrivers of model PZ2 and the tightening torque should be 1Nm; 5SY and 5SL series circuit breakers should be tightened with screwdrivers of model PZ2 and the tightening torque should be 2.5Nm; 3VT8 series circuit breakers should be tightened with suitable hexagonal wrenches and the tightening torque should be 10Nm.



The equipment must be tightened regularly on the wiring of the contactors and circuit breakers, if the wiring screws are loose it will cause the wires to burn at the joints and in severe cases it may cause a fire.

8.3.19 Generator water level probe (or float) and level gauge cleaning and descaling (built-in generator equipment)

After disassembling, scrub the probe and gauge with a rag to remove surface

scale, and test the correct water level after reinstallation.



The deposits or scale on the water level probe and float can cause water level monitoring failure, which may result in equipment alarms or dry burning of the heating tubes!

8.3.20 Clean the generator boiler and heating tube (built-in generator equipment)

Equipment with its own steam generator will produce scale during the heating process of the heating tube, and when used for a long time, too much scale accumulation will affect the overall performance of the equipment and the service life of the heating tube, so regularly descale the boiler and the heating tube to prolong the service life of the heating tube.

Power off the equipment, wait for the pressure in the chamber to drop to below 0.1MPa, open the drain valve, drain the water in the boiler, and wait for the body of the boiler to cool down to room temperature.

- 1) Remove the protective cover of the heating tube.
- 2) Remove the cable and take out the whole electric heater set.
- 3) Soak the heater set in oxalic acid solution, then rinse with water and wipe with a rag.
- 4) After cleaning and wiping, connect the cable, install the protective cover and resume normal use.



When disassembling the heating tube, please make sure to disconnect the equipment from power and drain the water inside the boiler, and wait until the body of the boiler cools down to room temperature before operating, otherwise it may cause serious personal and equipment damage.

8.3.21 Check whether the generator level display glass tube shows correctly, check whether the liquid level meter gasket leaks (built-in generator equipment)

Check whether the water level display is correct, whether there is any leakage, and tighten or replace the gasket in case of leakage.

8.3.22 Clean the internal electrical components of the electrical box and equipment valve sensors, etc.

Wipe the surface of the electrical components with a dry cloth to remove surface dust.

8.3.23 Check dry-burn protection (built-in generator units, if available)

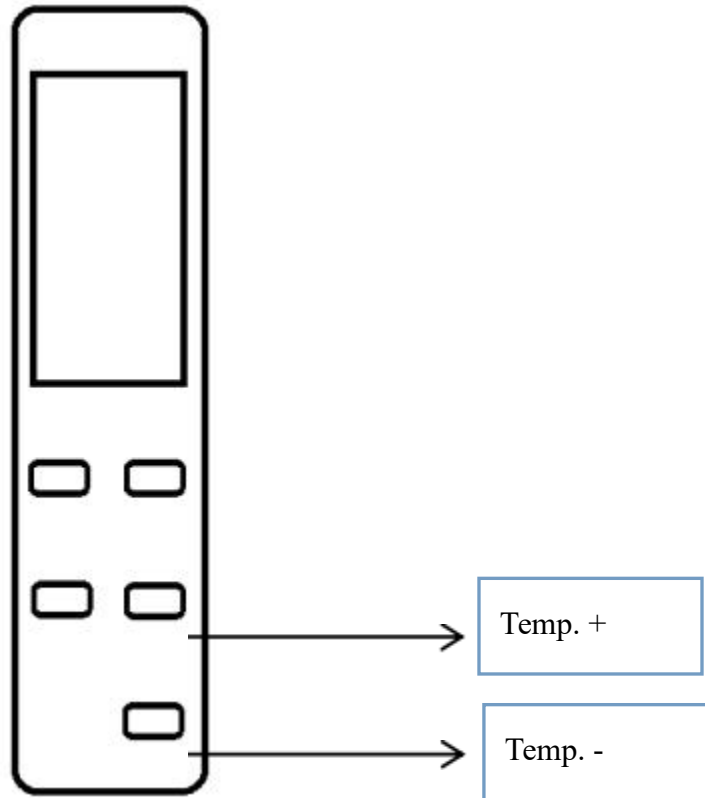

Figure 8-6 Dry-burn protection thermostat

To check the dry burn protection device as follows:

- 1) Rotate the key switch to OFF and click the temperature minus button to set the temperature controller alarm temperature to 130°C.
- 2) Rotate the key switch to ON, the device normal standby, wait for the heating tube temperature to rise.
- 3) Observe the device, whether the device alarm “[140] Generator temperature over-temperature” when the heating tube temperature exceeds 130 ° C. If alarms, the dry burning protection device is working properly; if not, the dry burning protection device failure.
- 4) Rotate the key switch to OFF, click the temperature plus button to set the

temperature controller alarm temperature to 150°C.



The equipment must be tested regularly for dry burning protection devices. Failure of dry burning protection devices may result in dry burning of the heating tube, which may cause a fire in severe cases.

8.3.24 Check the safety valve for water or steam leakage

Observe the safety valve installation port and discharge port for water and steam leakage.

If there is water or steam leakage that requires replacement, use a fork wrench or a live wrench to remove the safety valve and install a new one.

8.3.25 Check for water leakage from the heating tube (built-in generator equipment)

Check whether there is water droplet or rust near the terminals of the heating tube, if so, the heating tube needs to be replaced.

8.3.26 Check all wires of the equipment

Visually inspect and replace if frayed.

8.3.27 Check door safety, including all door position switches, barrier protection and hinge moving parts

Check door position switches and barrier switches for proper operation and proper switch position. Check hinge moving parts for proper action, no abnormal noise during action, and no loosening of fixing bolts.

8.3.28 Check that the upper limit of generator pressure is within the specified range (built-in generator unit)

When running the sterilization cycle, in the drying stage to observe and record the pressure when the heating tube stops heating, the pressure should not be greater than the safety valve opening pressure.

8.3.29 Clean all traps on equipment and steam pipelines(if available)

Remove the top fixing bolt of the trap, remove the temperature sensing element, remove the fixing nut on the strainer, and clean any impurities or foreign matter on top of the strainer.



Trap removal and cleaning should be carried out when the equipment cycle stops running, after waiting for the chamber and jacket steam to be completely drained and cooled down to room temperature, otherwise it will cause burns to the operator!

8.3.30 Check and tighten check valves

After disassembling the inlet end of the check valve, check for foreign objects or if the valve flap is working properly.

8.3.31 Door moving parts lubrication and inspection

Sterilizer transmission parts need to be lubricated regularly to ensure smooth and unobstructed door movement, add lubricant to the door transmission parts regularly.

8.3.32 Pressure transmitter connection inspection and descaling

After removing the pressure transmitter, inspect and clean the connections for dirt.

8.3.33 Check and clean the working fluid inlet and cavitation protection port of the vacuum pump, check the suction of the pump and run without leakage

After the equipment is powered off, disassemble the working liquid inlet and cavitation protection port of the vacuum pump, and check whether there is any foreign matter blocking.

When the equipment is running, check the vacuum pump for leakage.

8.3.34 Check the recent alarm records to find the cause and assess whether it is caused by component failure

Open the alarm record in the main menu interface to check and evaluate the

cause of the alarm and whether it is caused by component failure.

8.3.35 Check PT100 for leaks, breaks, knocks and wiring problems

Check PT100 connections for leaks, damage, knockouts and broken wiring during operation.

8.3.36 Check the pressure transmitter for water leakage, damage, bumping and wiring problems

Check the pressure transmitter connections for leaks, knocks and broken wires during operation.

8.3.37 Check the difference between the chamber temperature and the recorded temperature

Check the discrepancy between the chamber temperature and the recorded temperature during the sterilization phase, which should be no more than 1°C.

8.3.38 Periodically clean all water tanks of the equipment (if available)

Scrub all water tanks of the equipment with a clean rag to remove scale, rust and other dirt from the tanks.

8.3.39 Check whether the equipment drainage pipeline is smooth or not

Disassemble the equipment drain port and pour water into the drain pipe to check

whether the drainage is smooth and whether the drain port is overflowing.

8.3.40 Vacuum pump cleaning and descaling

- 1) Wear personal protective equipment (gloves and protective glasses).
- 2) Turn off the power.
- 3) Open the bottom of the pump cover to empty the plug, empty the equipment and then back to install the plug.
- 4) Remove the pipelines connected to the unit.
- 5) Fill the pump body with decalcifier through one of the connection openings. Use 10% acetic acid concentrate or other equivalent available decalcifying agent.
- 6) Leave the decalcification liquid in the unit for at least 30 minutes.
- 7) Remove motor fan cover and manually rotate motor fan to allow shaft to turn in normal operating direction.
- 8) Open the drain plug at the bottom of the pump cover and drain the decalcified liquid.
- 9) Flush the vacuum pump with clean water.
- 10) Manually start the sterilizer vacuum system, keep vacuum for 1min and keep flushing the vacuum pump.
- 11) Contaminants will be discharged from the pump with the flushing liquid.



During the descaling operation, be sure to prevent the decalcifier from coming into contact with the person's body to avoid burns to the skin!

8.3.41 Check that equipment warning labels are complete and diagrams are clear and easy to see

Check that the equipment warning labels for anti-scalding and other safety

warnings are not broken or missing, and that the illustrations are not contaminated and are clearly visible.

8.3.42 Check that the Operating Guide of the equipment are complete

Check that the Operating Guide for the equipment are complete and not defaced.

8.3.43 Check pressure safety interlock device

- 1) The door cannot be opened and alarmed when there is pressure in the chamber;

When the pressure in the chamber is less than -10KPa or more than 10KPa, the door cannot be opened and the alarms synchronized with the above actions.

- 2) Can not start cycle when the door not closed.

When the door is not locked, click to run the cycle, the cycle can not start, and the alarms synchronized with the above actions.

8.3.44 Check the front and rear door emergency stop switches (if available)

Run the cycle with no load, press the emergency stop button during the running process, all outputs of the device should stop until the emergency stop button is reset and the alarm is confirmed.

8.3.45 Confirm that all signal wires are not pinched when opening and closing doors

Operation confirms that all door opening and closing signal wires are not touched or pinched by door moving parts.

8.3.46 Confirm that all spare parts in the maintenance room are not affected by water vapor.

The inlet and exhaust air in the maintenance room is normal, there is no water or steam leakage from the equipment, and there is no water condensation on the ceiling and the surfaces of the components.

8.3.47 Confirm that the wire slot and terminal guard plate are complete and there is no potential danger of electric shock

Check that the wire slot and terminal protection boards are not missing and there is no danger of electric shock.

8.3.48 Check grounding impedance

Using a medical grounding impedance tester, measure the impedance between the protective grounding foot in the net power outlet and all accessible metal parts that have been protected from grounding, which shall not be greater than 0.1Ω .

8.3.49 Check whether the generator low liquid level switch is effective

Manually drain the water in the generator after the equipment is powered off, and there should be an generator water shortage alarm after the equipment is powered on again.

8.3.50 Check the integrity of the equipment and external pipeline insulation

Check whether the insulation of the equipment and external pipeline is complete and damaged or not.

8.3.51 Check the level of the front and rear door rails and fasten them

Check whether there is any skidding phenomenon, adjust the level of guide rail if necessary, and check whether there is any loosening of fixing bolts.

8.3.52 Check and clean the steam barrier

After the equipment is powered off, wait for the temperature of the chamber to drop to room temperature, remove the steam cooling system, wet a clean cotton cloth with water and wipe the inner and outer surfaces of the barrier and the surface of the chamber covered by the barrier.

8.3.53 Check and clean all flow restriction joints (if available)

Check all flow restriction joints in the pipelines for foreign matter or blockage after removal.

8.3.54 Check the vacuum pump shock pads are intact and stable

When running, check whether there is any obvious vibration or strange noise

when the vacuum pump is working, and whether the shock absorbing pad is broken.

8.3.55 Check all valves for leakage

Check all automatic and manual valves of the equipment for leakage when the equipment is running.

8.3.56 Check whether the key switch is in good contact or not

Check that key switch wiring is secure and not loose.

8.3.57 Calibrate the date and time of the equipment

Confirm the date and time, if there is any error, press the system setup button on the main menu screen to enter the auxiliary function screen, click the date and time button on the system setup screen to enter the date and time setup screen for time calibration.

8.3.58 Replace door gasket

During long time operation of the equipment, dust and other impurities in the environment will enter the sealing groove, resulting in contamination of the door gasket, which will affect the sealing performance and service life of the door gasket. Therefore, it is very important to clean the door gasket and sealing groove regularly. The following is the removal and installation of the door gasket.

When you need to take out the door gasket, open the door after stopping the operation of all cycles.

When installing the gasket into the sealing groove, place the shortest right-angled edge of the gasket at the outermost part of the inner diameter of the sealing groove,

mark it with a soft pen, and divide the whole gasket into two equal parts, and place both marks in the middle of the rounded part of the sealing groove. Then fix the corners, and then along the sealing groove of the flat part, divided into four equal parts, and make the excess part as far as possible evenly distributed, and then the door gasket carefully and evenly pressed into the sealing groove, the final check, the door gasket installation is finished.



In order to extend the service life of the door gasket and achieve the expected sealing effect, it is recommended that the door gasket should be cleaned once a week. The operation method is as follows: remove the gasket, wash the sealing groove carefully with soap solution, and then dry it with clean cotton cloth or gauze; gently scrub the gasket with alcohol, and then install it back into the sealing groove after drying.

8.3.59 Detect parameters such as temperature, pressure and time with a temperature and pressure tester

Entrust the manufacturer or a qualified third party to carry out temperature, pressure and time parameter testing, and conduct a comprehensive assessment of the equipment based on the test results.

8.3.60 Replace generator water level gauge pad(built-in generator equipment)

After the equipment is powered off, wait for the generator pressure to drop to 0.1Mpa, open the drain valve, drain the water, and then disassemble the water level gauge to replace the sealing pad.

8.3.61 Replace all clamp pads on the pipeline

After disassembling the clamps, remove the old clamp pads, clean the pipe opening and place the new clamp pads in the right place, then install and tighten the clamps.

8.3.62 Replace the air filter element

The efficiency of the air filter element decreases after a long time of use, which in turn affects the filter's ability to filter out bacteria and impurities in the air. The filter disassembly and replacement sequence is as follows:

- 1) Remove the fixing nuts at both ends of the filter first.
- 2) Rotate the filter, remove the filter shell, and take out the filter element and filter mesh.
- 3) After replacing the filter element, put it back as it was.

8.3.63 Remove and the clean bolts

Remove and clean bolts and replace them as required.

8.3.64 Clean the printer thermal printer head

- 1) Loosen the printer head snap;
- 2) Wipe the printer head with a cotton cloth and alcohol.

8.3.65 Check the integrity of the nameplate

Check the equipment nameplate for defacement and missing parts.

8.3.66 Replace PLC Battery

Remove the controller housing, locate the battery mounting plate, clean the battery mounting slot after removing the old battery and replace with a new battery, model CR2032.

8.3.67 Vacuum pump maintenance

- 1) Remove the motor fan cover, manually rotate the motor fan, check the bearings for jamming points, strange noise problems, replace the bearings and shaft seals if necessary.
- 2) Remove the bolts connecting the pump cover and the pump body, check whether there are wear and tear and cavitation problems on the impeller and disk, and check whether there are grooves formed by working fluid flushing in the inner cavity of the pump body, and replace them if necessary.
- 3) Place the pump cover disc assembly, on the rubber mat, with the disc facing down, and use the bolt to gently tap the working fluid drain at the bottom of the pump cover to separate the disc from the pump cover. Replace the disk pad, valve plate, and cavitation protection pad.

8.3.68 Replace generator heating tube contactor (built-in generator unit)

- 1) Disconnect the power switch in the user's wall power switch box;
- 2) Remove the old contactor and wiring, and take pictures of the wiring position and sequence before removal; replace the new contactor of the same type and specification (or a replaceable model approved by the sterilizer manufacturer), and recover the wiring of the contactor and check the wiring diagram according to the photographs, and the wiring fastening parameters follow the requirements

of the product specification.



The equipment must regularly replace the generator heating tube contactor, contactor overuse may lead to contactor sticking, and in serious cases, it may lead to heating tube burn out or cause fire.

8.4 Parts List

Order No.: XG1.UCD-100M

Table 8- 1 XG1.UCD-100M Parts List

SN	P&ID	Name	Place of Origin	Diameter/range	Quantity
1	F2	Solenoid Valve	Japan	Rc3/8	1
2	F4, F5, F6, F7	Solenoid Valve	Japan	Rc1/4	4
3	F0,F3	Solenoid Valve	Japan	Rc1/2	2
4	B	Vacuum pump	Germany	Rc1	1
5	GB	Water pump	Italy	Rc 1/4	1
6	T1	Temperature probe	Zibo	0~180°C	1
7	NA	Air filter	Lianyungang	R1/4	1
8	NA	Sealing strips	Shandong	NA	2
9	NA	Travel switches	Japan	NA	2
10	NA	Pressure transmitters	Germany	NA	2
11	NA	Control system	China	NA	1

Order No.:XG1.UCD-135M、 XG1.UCD-185L

Table 8- 2 XG1.UCD-135M、 XG1.UCD-185L Parts List

SN	P&ID	Name	Place of	Diameter/range	Quantity
----	------	------	----------	----------------	----------

			Origin		
1	F2	Solenoid Valve	Japan	Rc3/8	1
2	F4, F5, F6, F7	Solenoid Valve	Japan	Rc1/4	4
3	F0,F3	Solenoid Valve	Japan	Rc1/2	2
4	B	Vacuum pump	Germany	Rc1	1
5	GB	Water pump	Italy	Rc 1/4	1
6	T1	Temperature probe	Zibo	0~180°C	1
7	NA	Air filter	Lianyungang	R1/4	1
8	NA	Sealing strips	Shandong	NA	2
9	NA	Travel switches	Japan	NA	2
10	NA	Pressure transmitters	Germany	NA	2
11	NA	Control system	China	NA	1

Order No.:XG1.UCD-300M

Table 8- 3 XG1.UCD-300M Parts List

SN	P&ID	Name	Place of Origin	Diameter/range	Quantity
1	F2	Solenoid Valve	Japan	Rc3/8	1
2	F5, F6, F7	Solenoid Valve	Japan	Rc1/4	3
3	F0, F4, F3	Solenoid Valve	Japan	Rc1/2	3
4	B	Vacuum pump	Germany	Rc 1	1
5	GB	Water pump	Italy	Rc 1/4	1
6	T1	Temperature probe	Zibo	0~180°C	1
7	NA	Air filter	Lianyungang	R1/2	1
8	NA	Sealing strips	Shandong	NA	2
9	NA	Travel switches	Japan	NA	2
10	NA	Pressure transmitters	Germany	NA	2
11	NA	Control system	China	NA	1

8.5 Common problems

8.5.1 How to check and replace the safety valve

- 1) To prevent the safety valve from being in a blocked condition, allow steam pressure to be released through it once a month during normal use.
 - Do the sterilization operation according to the Manual.
 - Make a pressure of 0.21MPa in the sterilization vessel.
 - Push the safety valve pull ring with a screwdriver, making it to be in the open position for about 2 seconds.
 - Close the main switch to terminate the operation. At the same time, discharge the water steam in the sterilization vessel.
 - Wait until the pressure drops to 0MPa before opening the door.
- 2) Replace the safety valve: (This operation is only for professional personnel)
 - Remove the safety valve.
 - Replace it with a qualified safety valve. (Qualified standard: Ensure that the safety valve opens when the pressure is between 0.24MPa and 0.25MPa).
 - Test a sterilization process.
 - Once a year, test the safety valve opening pressure and closing pressure.

8.5.2 Procedure for replacing the electric heating tube

This operation is for professional personnel only.

- 1) Remove the rear cover of the sterilizer.
- 2) Remove wiring from steam generator heaters.
- 3) Remove the heaters.
- 4) Replace the damaged heater with a new one.
- 5) Re-wire the steam generator.
- 6) Install the rear cover of the sterilizer.

- 7) Test a sterilization process.

8.5.3 Cleaning of solenoid valve

- 1) Remove the outer cover of the sterilizer.
- 2) Use a screwdriver to remove the stainless steel pressure plate on top of the solenoid valve to be cleaned or use a wrench to remove the nut on the coil.
- 3) Lift up the solenoid valve coil.
- 4) Open the valve body with a wrench.
- 5) Rinse the solenoid valve debris with water.
- 6) Reinstall the solenoid valve.

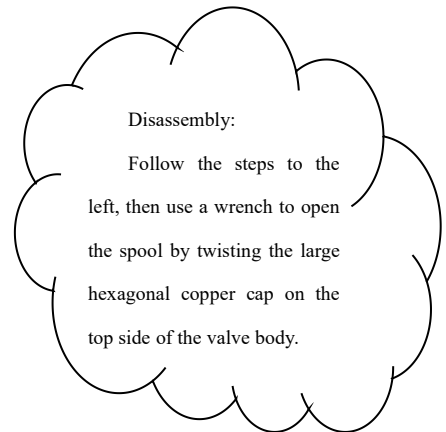
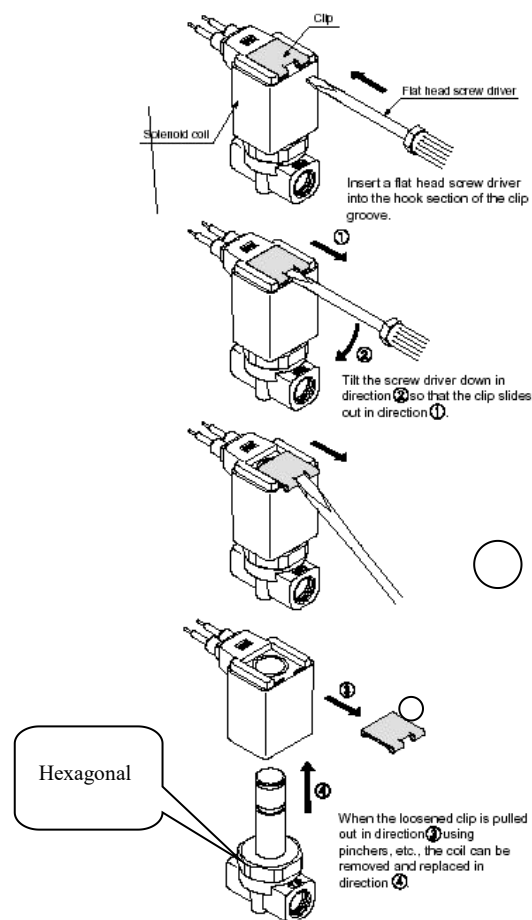

8.5.4 Cleaning of inlet and drain filters

- 1) The water inlet filter is used to prevent foreign matter from entering the generator.
- 2) The drain filter is used to prevent foreign matter from entering the internal piping and solenoid valve.
- 3) Remove the filter lid with a wrench and take out the mesh.
- 4) Clean the filter mesh debris with water.
- 5) Reinstall the filter.

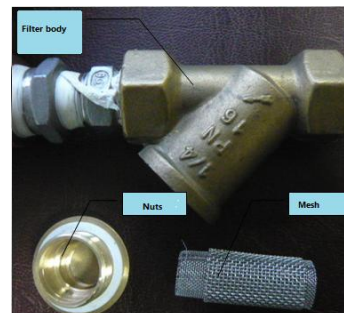
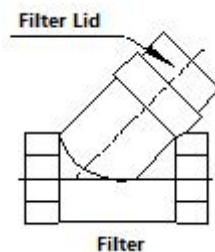

8.5.5 Replace the water level detection device



WARNING: Make sure the power is off and the unit is disconnected!

- 1) Remove the rear cover of the sterilizer.
- 2) Remove the wiring for the high and low water level probes.
- 3) Remove the high and low water level probes.
- 4) Replace the damaged water level probe with a new one.
- 5) Reinstall the water level detector and wire.
- 6) Install sterilizer rear cover.
- 7) Retest all working processes to prevent leakage, wiring errors, installation

jamming, etc.

8.5.6 Use and maintenance of the printer

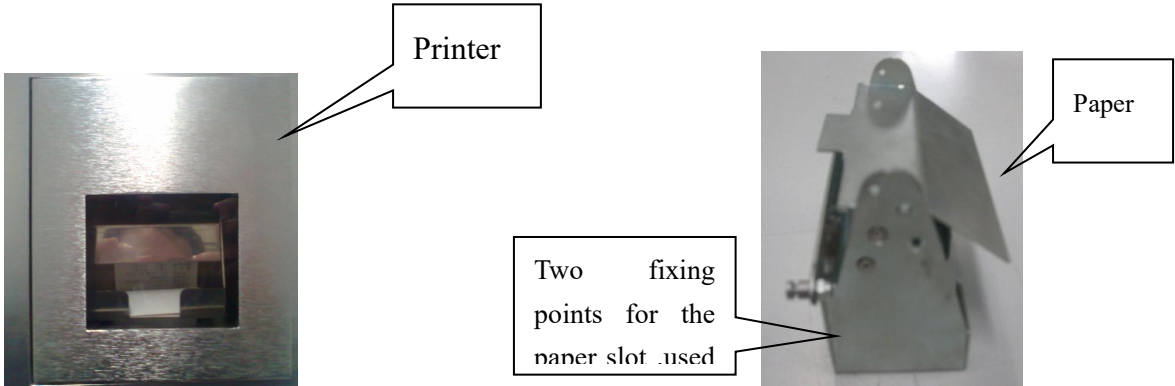

Gently press the lower right corner of the window door, the window door pops open; if you want to take out the hanging paper slot, please press the folding paper stopper by hand firstly, and then lift the hanging paper slot upward and take it out.

The appearance of the printer to store the folded paper slot after printing press the stopper

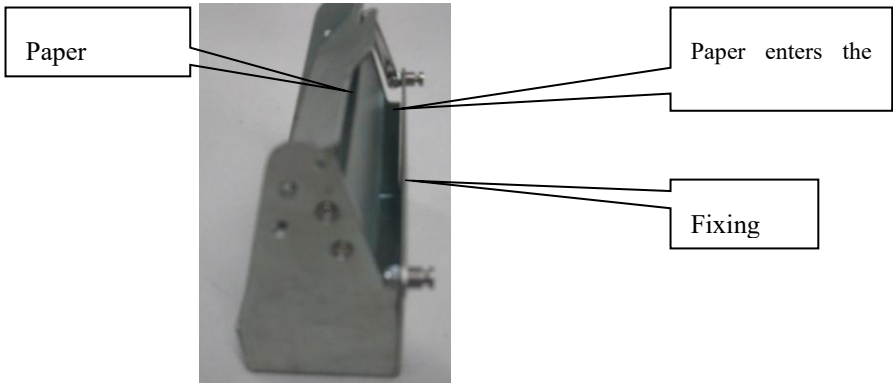

Note: Folded paper should enter the folding slot between the stopper and the fixed plate.

Press the lower right corner of the printer window door or the upper right corner, when you hear the faint sound of the switch closed to let go, the window door can be popped open, this printer uses a folded paper printing, after printing the paper is automatically folded and stored in the paper slot.

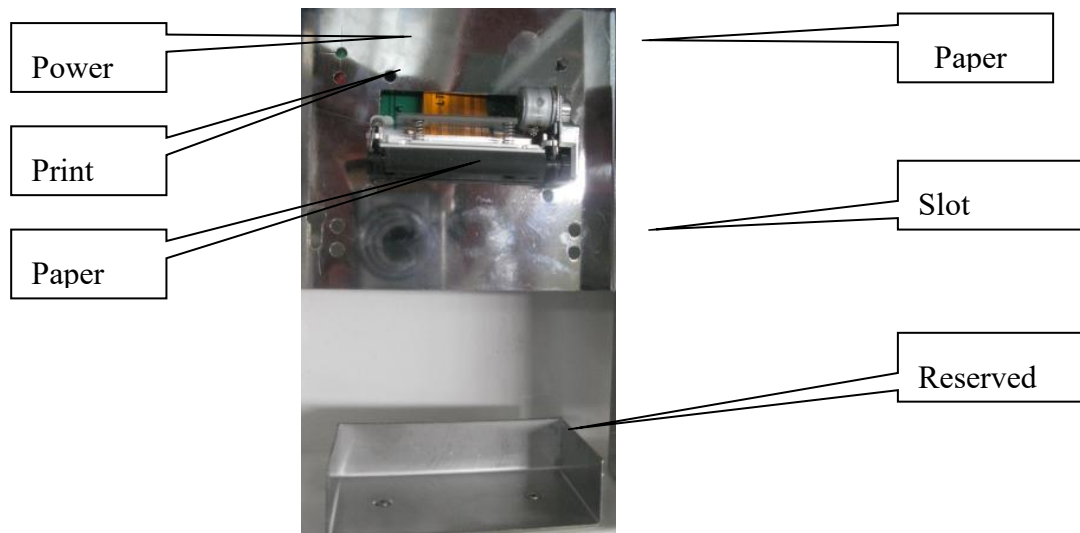

Open the printer window to take down the paper slot appearance

After opening the printer window door as shown in the figure shows that the upper left corner of the green light is the power indicator, the lower part of the red print indicator, the upper right corner of the paper button (press when the print paper will quickly go paper); when the printer is working the red indicator light, when replacing the print paper, first of all, the hanging paper slot removed, and then the print paper inserted horizontally into the paper slot, hold down the upper right corner of the paper button (power) turn on) the folded paper will automatically walk in and hang the paper slot where the recording paper is stored.

8.5.7 Components to be maintained and replaced by specialized personnel only



When replacing or servicing the following components, please contact a qualified person, and do not allow the user to replace or service them privately.

The following is a list of parts that should only be maintained and replaced by qualified personnel:

Order No.: XG1.UCD-100M

Table 8-4 XG1.UCD-100M Parts List

SN	P&ID	Name	Place of Origin	Diameter/range	Quantity
1	F2	Solenoid Valve	Japan	Rc3/8	1
2	F4, F5, F6, F7	Solenoid Valve	Japan	Rc1/4	4
3	F0,F3	Solenoid Valve	Japan	Rc1/2	2
4	B	Vacuum pump	Germany	Rc1	1
5	GB	Water pump	Italy	Rc 1/4	1
6	T1	Temperature probe	Zibo	0~180°C	1
7	NA	Air filter	Lianyungang	R1/4	1
8	NA	Sealing strips	Shandong	NA	2
9	NA	Travel switches	Japan	NA	2
10	NA	Pressure switches	Japan	NA	4
11	NA	Pressure transmitters	Switzerland	NA	2
12	NA	Control system	China	NA	1

Order No.: XG1.UCD-135M、XG1.UCD-185L

Table 8-5 XG1.UCD-135M、XG1.UCD-185L Parts List

SN	P&ID	Name	Place of Origin	Diameter/range	Quantity
1	F2	Solenoid Valve	Japan	Rc3/8	1
2	F4, F5, F6, F7	Solenoid Valve	Japan	Rc1/4	4
3	F0,F3	Solenoid Valve	Japan	Rc1/2	2
4	B	Vacuum pump	Germany	Rc1	1

5	GB	Water pump	Italy	Rc 1/4	1
6	T1	Temperature probe	Zibo	0~180°C	1
7	NA	Air filter	Lianyungang	R1/4	1
8	NA	Sealing strips	Shandong	NA	2
9	NA	Travel switches	Japan	NA	2
10	NA	Pressure switches	Japan	NA	4
11	NA	Pressure transmitters	Switzerland	NA	2
12	NA	Control system	China	NA	1

Order No.: XG1.UCD-300M

Table 8- 6 XG1.UCD-300M Parts List

SN	P&ID	Name	Place of Origin	Diameter/range	Quantity
1	F2	Solenoid Valve	Japan	Rc3/8	1
2	F5, F6, F7	Solenoid Valve	Japan	Rc1/4	3
3	F0, F4, F3	Solenoid Valve	Japan	Rc1/2	3
4	B	Vacuum pump	Germany	Rc 1	1
5	GB	Water pump	Italy	Rc 1/4	1
6	T1	Temperature probe	Zibo	0~180°C	1
7	NA	Air filter	Lianyungang	R1/2	1
8	NA	Sealing strips	Shandong	NA	2
9	NA	Travel switches	Japan	NA	2
10	NA	Pressure switches	Japan	NA	4
11	NA	Pressure transmitters	Switzerland	NA	2
12	NA	Control system	China	NA	1

9 Others

Any kind of disinfection and sterilization equipment, whether it is gravity or cycle automatic control form, if you want to achieve reliable sterilization effect, in addition to the design of the equipment itself, the quality of manufacturing and perfect maintenance, whether the personnel doing disinfection work correctly grasp the basics knowledge of disinfection and sterilization, familiar with the principle of the equipment, strict disinfection sterilization operation norms, and seriously treat each and every sterilization-related provisions is the human factor to obtain the success of the sterilization.

9.1 Self-protection

When disinfection, the staff must have a sense of self-protection and the ability to take self-protection, to prevent sterilization accidents and improper operation methods of personnel injury.



Sterilization equipment working at high temperature, should pay special attention to scalding.

9.2 Sterilization quality assurance

1) Ensure the cleanliness of the sterilized items

Cleanliness is the key to the success of sterilization. Especially some of the more difficult to clean medical supplies, foreign research has found that a thorough cleaning can reduce the amount of 3 to 4 log bacteria, can greatly reduce the content of organic matter, if you can not effectively remove the organic matter and other pollutants, it will greatly reduce the activity of the sterilizing agent, hidden in the organic matter

within the bacteria are not easy to be killed by the sterilization agent, so if the cleaning is not thorough, the entire sterilization process will fail. It must be noted that, not by extending the sterilization time and increase the temperature of the sterilization agent to reduce the cleaning requirements, in order to facilitate the effective removal of organic matter, it is best to use enzyme-containing cleaners to enhance the effect of cleaning. Cleaning has manual cleaning and machine cleaning. Manual cleaning is time-consuming and labor-intensive, and does not ensure consistency in each cleaning. In addition, manual cleaning medical personnel must wear waterproof masks, eye masks, gloves, cuffs, hats, waterproof shoes and aprons, etc.; machine cleaning investment, but can ensure the consistency of the cleaning; but it must be noted that: the machine cleaning can not be a total replacement for manual cleaning, for some pipelines, fine instruments and difficult to clean the parts of the cleaning must be manually cleaned; in addition to cleaning equipment must be cleaned often and maintenance to avoid Machine cleaning failure.



Without proper cleaning, can not guarantee a high level of disinfection or sterilization.

2) Control of water quality

Water hardness is divided into two categories: one is temporary hardness, mainly formed by calcium, magnesium bicarbonate, etc.; the other mainly formed by calcium and magnesium sulfate, nitrate and chloride hardness, it can not be removed by boiling, so it is also known as permanent hardness.

Because the sterilization equipment is in the hot and humid conditions for a long time, the impurities in the water, such as dissolved oxygen, carbon dioxide, hydrogen sulfide, chloride, etc., whether gaseous or particulate, are on the stainless steel and metal intergranular corrosion. Therefore, the PH value of the water supply and steam supply of sterilization equipment is required to be between 7 and 7.8, and the water used for boiler and sterilization equipment must be treated.

3) Sterilization room environment

- The floor of the disinfection and sterilization room must be flat and smooth, with a cement floor, slightly inclined to the wastewater discharge port, to keep the operation area neat and dry. The roof should be supplemented with a ceiling to prevent dust from gathering. The walls should be flat and clean and isolated from the rinsing, preparation and other studios.
- Exhaust vapor and wastewater vents must exit through the walls or be buried in a gutter or discharged to the atmosphere; do not allow residual water or vapor to return and intrude into the room.
- Ventilation devices are installed at appropriate locations on the top end of walls or ceilings

4) Preparation and placement of items

- Dressing fabrics should be folded and wrapped loosely to facilitate steam penetration.
- Packages placed on the shelf, each other should maintain a gap of 10mm, the loading should not exceed 90% of the volume of the chamber, in order to facilitate the smooth flow of steam.
- Commercially available aluminum lunch box and enamel box, shall not be used to load the items to be sterilized, should be loaded with ventilation holes in the apparatus.

5) Requirements of the sterilized items

- Try to sterilize a batch of similar items, and avoid direct contact of instrument packages with cotton fabric packages.
- The volume of the item package used for sterilization shall not exceed 30cm×30cm×50cm.
- Items package bundling should not be too tight, to ensure that each package is placed inside with the chemical indicator.

6) Clean the sterilization chamber(chamber)

- When the temperature of the sterilization chamber and shelves has dropped to near room temperature, scrub them with a neutral detergent, then rinse them well with tap water, and finally dry them with a lint-free cloth.
- Clean the fiber chips and deposits attached to the filter in the front of the chamber, to ensure that the vacuum rate and condensate flow smoothly as well as the indication of the temperature coincides with the pressure.

9.3 Detection of sterilization effect

Detection of sterilization effect is the necessary means to evaluate the sterilization method is reasonable, sterilization effect is a reliable or not.

Detection methods are divided into physical methods, chemical detection methods, biological detection methods:

1) Physical methods:

- Instrumentation detection: the device is equipped with a pressure gauge to display the pressure of the jacket (if available) and the chamber, and in the touch screen display has the chamber temperature and pressure values, the device also has a micro printer, the printer can be recorded out of the sterilization process of each state of the pressure, temperature and the corresponding time value, but also record the nature of the use of the program, the number of pulsations, the sterilizing time, the drying time, Sterilization temperature and other parameters, by observing the value of these parameters and whether the requirements are consistent with the initial judgment of the sterilization effect is good or bad.
- Stationary point thermometer detection: the structure of stationary point thermometer is the same as thermometer, but its maximum temperature up to 180 °C, need to be thrown to below 50 °C when used. When used in the center of the sterilization package will be placed in the center of the position, placing several stationary point thermometer to test the temperature of each

point, to observe whether the display temperature value to reach the required temperature after sterilization. The disadvantage of this method is that it can only display the temperature, and cannot indicate the duration of the point at that temperature.

- Thermocouple detection: the method is to put the electrode of the thermocouple into the part of the sterilizer to be tested, close the cabinet door and lead the wires out of the validator to analyze the data, the computer will be tested by the temperature value of each point of the temperature value of the timely display, the use of this method can be detected in the inner chamber of the sterilizer at each point of the uniformity of the temperature and the stability of the sterilization temperature.

2) Chemical detection method:

- Chemical indicator: this type of indication card can be divided into 115 °C, 121 °C and 132 °C pressure steam sterilization effect detection of chemical indicator. When using the chemical indicator that can indicate both the temperature and the duration of the temperature into the middle of the dressing package to be sterilized, after a sterilization cycle, take out the indicator, and with the standard color for comparison and judgment, if the indicator color is deeper than the standard color, the sterilization qualified, if not, it need to be re-sterilized.
- Chemical indicator tape: the tape is coated with adhesive on one side and chemical indicator on the other side. Can be used as a distinction between “sterilized” and “not sterilized” instructions, but also as a package seal pasted on the exterior of the dressing package. After sterilization, the uniform blackening of the color of the indicator can tell whether it has been sterilized or not, thus further proving whether it is successfully sterilized or not.



The chemical indicator used for detection must be approved by the health department and used within its validity period!

3) Biological detection methods:

Biological detection refers to the use of live microorganisms on the sterilized items for testing to identify whether all the microorganisms in the sterilized items are dead, to assess whether the sterilization equipment sterilization of the final means of testing.

- Calibration indicator bacteria: take the international most difficult to be killed, heat-resistant ability of the strongest “thermophilic fat bacillus” spores as a sterilizing indicator.
- Culture medium: the test medium is bromocresol purple peptone water medium.
- Detection method: put two slices of *Lipobacillus thermophilus* bacillus spores into a sterilized paper bag and placed in the middle of the standard test package (package size 25cm×30cm×30cm). Put the test package in the sterilization room above the exhaust port, at the end of sterilization, in sterile conditions, remove the standard test package, put into the bromocresol purple peptone water medium, incubated at a temperature of 56 °C for 7 days, to observe the change of the color of the medium. Negative control and positive control were set up for the test.
- Result: The color of all the culture media does not change and is judged to be sterilized. If the color changes from purple to yellow, it is considered as sterilization failure.
- Disposal: If the sterilization fails, the batch can be temporarily sealed first to find out the possible reasons for the sterilization failure, and then re-sterilize the process; the sterilization effect of the sterilizer can also be re-tested with multiple or more bio-indicators of the same type from the same manufacturer;

carefully check the date of production of the bio-indicator, the expiration date, whether there is any breakage and whether there is any contamination in the process of cultivation.

- It is permissible to use other test methods approved by the Ministry of Health, referring to their instructions for use, for biological testing of sterilization effectiveness.
- The equipment is commissioned before normal use or after the equipment has been overhauled, it should pass three consecutive biological tests before being put into use.

The equipment is commissioned before normal use or after the equipment has been overhauled, it should pass three consecutive biological tests before being put into use.

Physical detection, chemical detection, biological detection of these three methods have their own different purposes and significance, so they can not replace each other, should be used in conjunction with each other.

Physical detection - can explain the operation of the sterilization equipment itself, can visualize the work process time, temperature, pressure and other relevant parameters.

Chemical detection - can detect whether the sterilization process is completed, you can understand how the penetration of steam on the package, can provide the first visual inspection in the instant after the completion of sterilization, to assist in determining the effect of sterilization.

Biological detection - mainly used for the final judgment of the sterilization effect, but its high cost and long time, so it is not possible to use every package or every cycle.

4) B—D Test

B-D test is designed by two Scottish microbiologists Bowie (J.H. Bowie) and Dick (J. Dick) in 1963, dedicated to testing the effect of vacuum-type pressure steam

sterilizer air discharge test.

- Vacuum Test Chart: It is made of a mixture of many kinds of chemicals through a certain carrier to make indicator ink, and through a specific printing method to print the indicator ink on a special size of paper with a certain permeability to form a certain pattern, which will become a B-D Test Vacuum Test Chart. The chemical indicator on this test chart is sensitive to residual air and can detect the presence or absence of residual air in the test kit.
- B-D Test: This test should be performed before the first sterilization each day. The experiment is to place the vacuum test chart in the middle position of the test kit (disposable B-D test kit can also be used), and then place the test kit in the sterilization chamber at the exhaust port, close the cabinet door, and carry out the sterilization test according to the set parameters of sterilization (134 °C for 4min), the end of the sterilization, open the cabinet door, unlock the test kit, take out the test chart, and observe the test results.
- Preparation of the test kit: the test kit consists of cotton cloth towel of 46-50 cm×80-90 cm size, which is first folded horizontally into three layers, and then folded vertically into six layers. Folded cloth towel a stack of one to a height of 25cm. When stacking the layers of cloth towel according to the folding side of the left and right alternately, in order to make both sides of the thickness is equal. After the cloth towel is arranged, the vacuum test chart will be placed between the central layer of cloth towel, then wrapped with a cloth towel, the outside of the chemical indication adhesive tape to fix, become a test package. The size of the whole test package is about 27-30cm long, 23-25cm wide, 25-28cm high, and 4-5kg in weight.
- Results to determine: test chart blackened and uniform, that is, the central part and the edge of the part of the color is the same, that is, the air is discharged thoroughly, the sterilizer evacuation system is good, can be used. If the test chart changes color unevenly, usually the central part is lighter than the edge

part of the color, indicating that the air is not thoroughly discharged, the sterilizer is not good performance, repair before use.

- Precautions: the cloth towel has been washed at least once before use, but not hot ironing, because excessive drying will affect the test results; repeated use of the test package, the cloth towel must be washed, continuous testing, each time the package should be opened, the cloth towel will be dried for 1 hour, and then re-packed, the cloth towel is too wet will affect the test results, the package is suitable for loose, do not be too tight or too small.
- Necessary requirements: the name of the sterilized package; the date of sterilization or expiration date; the name or code name of the device checker and packer; and the sterilization mark on the seal.
- The results only indicate the vacuum status of the device and the amount of cold air residue, and do not express whether the sterilized item is sterilized or not.

9.4 Energy saving and environmental protection

Although the equipment in the design process has been fully considered in the protection of the environment and the operation of the process of energy saving, but you may use the equipment for special items of disinfection and sterilization, so you should get in touch with our company in time, so that we can make appropriate adjustments to your use of the program, so that it is more limited to reduce the consumption of energy saving.

Appendix

Appendix A Operation Guide

Appendix B Installation Drawings

Appendix C Electrical Drawings

Appendix A Operation Guide

Applicable to XG1.UCD

- ✓ Open the water source supply.
- ✓ Turn the power switch of sterilizer to “ON” side, make proper preparation for operation of the program.
- ✓ Open the door, loading the packages into the chamber, and make sure that there is clearance between every two packages and no packages contacts with inner wall or door plate.
- ✓ Log on and close the front door, select the appropriate sterilization program, start the program.
- ✓ In the course of sterilization, the operator may not get far away from this equipment, but shall closely observe the operation of equipment. If any abnormal situation is found, please handle it in time, so as to prevent the occurrence of any accident.
- ✓ Monitor the sterilization effect and properly make and retain the record, so as to ensure the traceability.
- ✓ After the sterilization is completed and the pressure in sterilizing chamber returns to zero, open the door and unloading the packages.
- ✓ After taking out the sterilized packages from the sterilizer, put it in an appropriate place, so as to prevent the secondary contamination.

Works after Operation:

- ✓ Open the door, turn the power switch to “OFF” side, and cut off the power supply.
- ✓ Discharge the residual water in boiler (or fully discharge the water accumulated in boiler in accordance with the required interval).
- ✓ After the works are completed every day, please keep the inside and outside of sterilizer clean, clear away all dirt from the chamber, carry out simply maintenance once a week, and carried out thorough maintenance once a month.

Notices:

- ✓ No packages which has been sterilized may be placed together with unsterilized packages.
- ✓ The packages which have been successfully sterilized shall be marked with sterilization date and qualified sign.

Appendix B Installation Drawings 1

XG1. UCD-100M

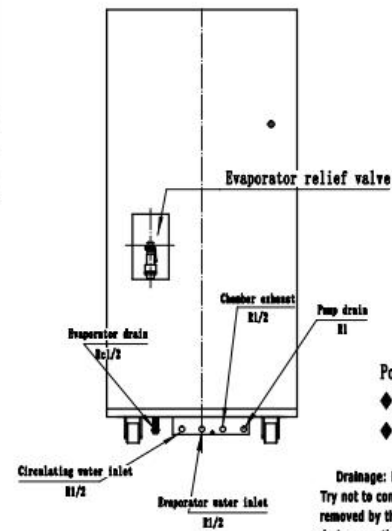
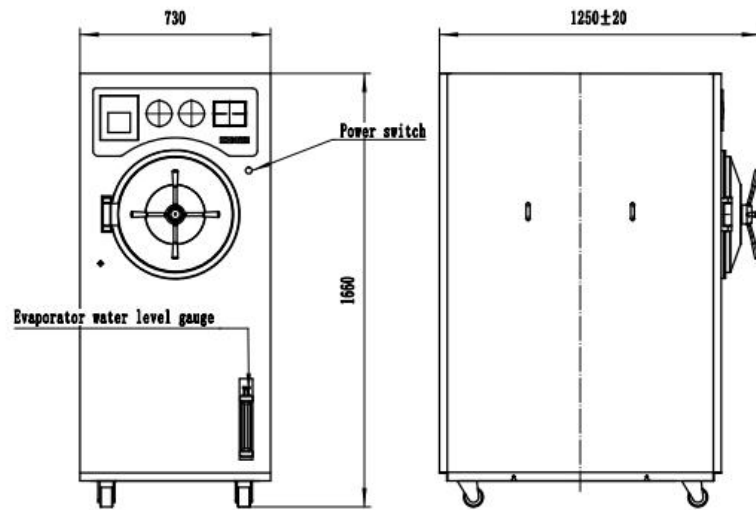

Power:

- ◆ Power not less than 11KW
- ◆ 380V/50Hz AC. Reliable grounding

Drainage: Lead the drainage pipe to the trench separately and drain it out of the room. Try not to communicate with other drainage pipes in the room, otherwise some vapor removed by the equipment during operation will affect other rooms. If there are multiple drainage outlets, they shall be led out separately.

Water source: reliable inflow ($\leq 25\text{ }^{\circ}\text{C}$, pressure 0.05-0.10 MPa). If the water source pressure is not within the required range, please adjust the pressure before starting the equipment. The water source should be soft water.

In order to observe the pressure of the water source in time and conveniently, a pressure gauge and valve with a measuring range of 0 ~ 0.4 MPa should be connected to the water pipeline entering the sterilizer so as to observe and control the water inflow.

Note: Do not use water with too high hardness, otherwise it will affect the working performance of the pump and condenser.

Power cord: The power supply of AC380V equipment shall be three-phase five-wire system, three-phase live wire, one zero wire and one ground wire. The zero line is light blue and the ground line is yellow-green. The load capacity of the user's power supply and power cord shall be greater than the load of the equipment. It is required to install a power switch box on the right or right rear wall of the sterilizer. A three-phase knife switch (or circuit breaker) and a single-phase knife switch (or circuit breaker) must be installed in the switch box.

Appendix B Installation Drawings 2

XG1. UCD-135M/185M

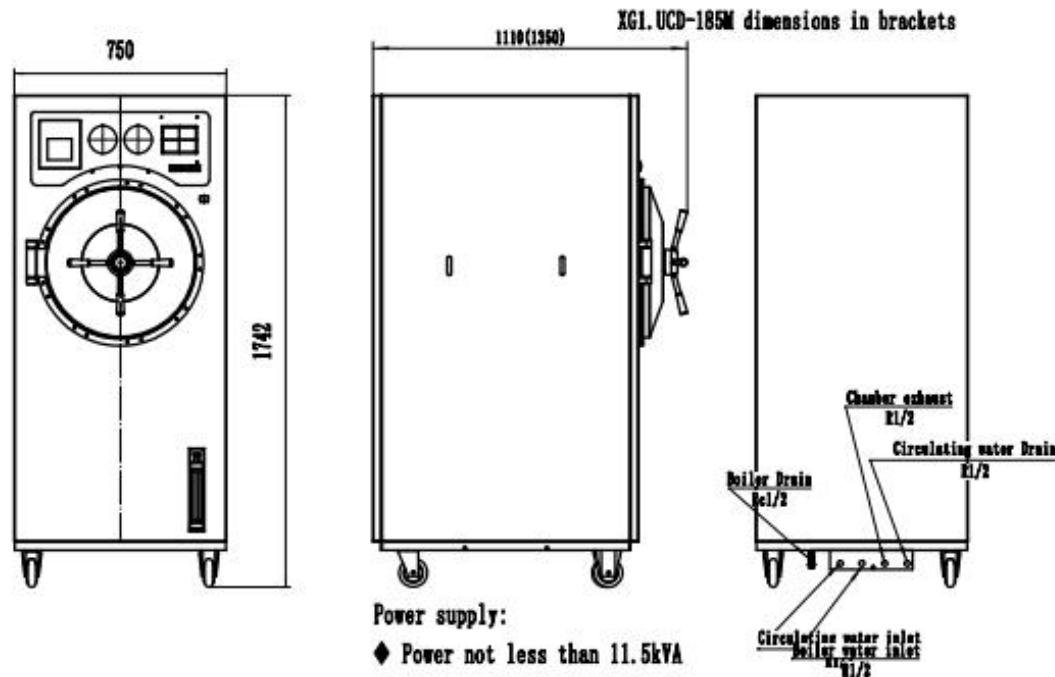

Power supply:

- ◆ Power not less than 11.5kVA
- ◆ 380V/50Hz AC, with reliable grounding.

Technical Requirements

Drainage: lead the drain pipe to the gutter separately to discharge outdoor, the drain pipe and the gutter is resistant to high temperature of 150 degrees Celsius, try not to be connected with other indoor drainage pipelines, otherwise some of the vapors excluded from the working process of the equipment will affect the other rooms. If there are more than one drainage port, it should be led out separately.

Water source: Reliably connect the circulating water inlet of the vacuum pump ($\leq 25^{\circ}\text{C}$, pressure 0.05-0.10MPa). If the pressure of the circulating water source is not within the required range, please adjust the pressure before starting the equipment.

In order to timely and conveniently observe the pressure of the water source, a pressure gauge and valve with a range of 0-0.4MPa should be connected to the water pipeline into the sterilizer, so that the water inlet can be observed and controlled.

Note: Do not use water that is too hard, or it will affect the working performance of the pump and condenser.

Power cord: conventional equipment power supply AC380V should be three-phase five-wire system, three-phase fire, a zero line, a ground line. Where the zero line is blue, the ground line is yellow-green, three fire wire is red, yellow and green, the user power supply and power line load capacity, should be greater than the load of the equipment. Requirements for the right side of the sterilizer or right behind the wall to install a power switch box, to ensure that the switch box is in close proximity to the equipment, and the operator is easy to reach the place, the switch box should be labeled as a special sterilizer. The switch box must be installed with a three-phase switch (or circuit breaker) and an overcurrent protection device to realize the function of power on/off and overcurrent protection of the equipment. Specialty equipment is wired in accordance with actual contract requirements for power supply. In order to ensure the safety of persons and equipment, a ground wire must be laid, and the ground wire in the equipment enclosure and control cable must be reliably connected to the external ground.

Appendix B Installation Drawings 3

XG1. UCD-300M

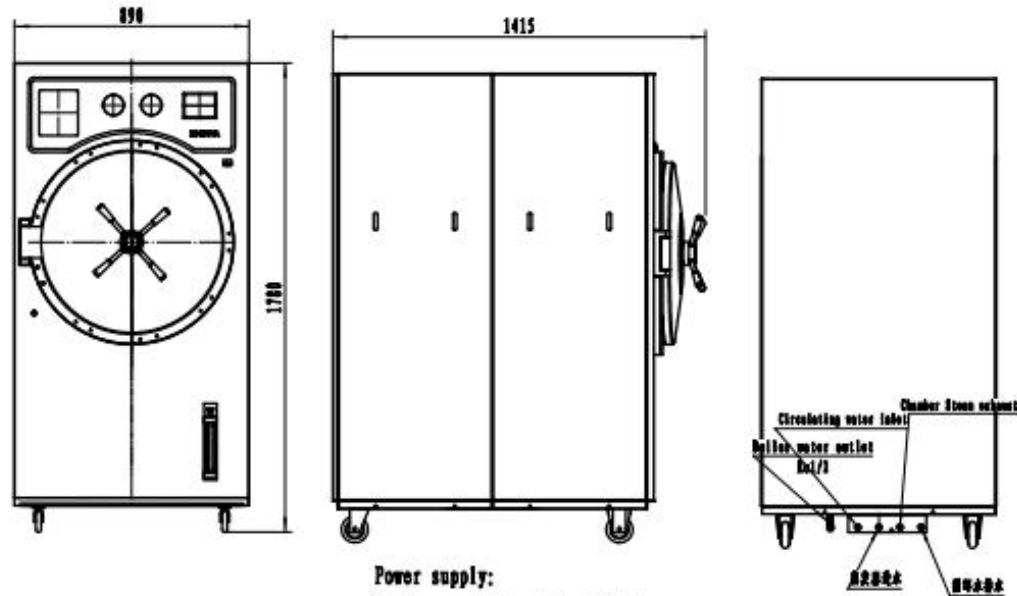

- Power supply:**
- ◆ Power not less than 18kVA
 - ◆ 380V/50Hz AC. With reliable grounding.

Technical Requirements

Drainage: lead the drain pipe to the gutter separately to discharge outdoor, the drain pipe and the gutter is resistant to high temperature of 150 °C, try not to be connected with other indoor drainage pipelines, otherwise some of the steam excluded from the working process of the equipment will affect the other rooms. If there are more than one drainage port, it should be led out separately.

Water source: Reliably connect the circulating water inlet of the vacuum pump (< 25°C, pressure 0.05-0.10MPa). If the pressure of the circulating water source is not within the required range, please adjust the pressure before starting the equipment.

In order to timely and conveniently observe the pressure of the water source, a pressure gauge and valve with a range of 0-0.4MPa should be connected to the water pipeline into the sterilizer, so that the water inlet can be observed and controlled.

Note: Do not use water that is too hard, or it will affect the working performance of the pump and condenser.

Power cord: conventional equipment power supply AC380V should be three-phase five-wire system, three-phase fire, a zero line, a ground line. Where the zero line is blue, the ground line is yellow-green, three fire wire is red, yellow and green, the user power supply and power line load capacity, should be greater than the load of the equipment. Requirements for the right side of the sterilizer or right behind the wall to install a power switch box, to ensure that the switch box is in close proximity to the equipment, and the operator is easy to reach the place, the switch box should be labeled as a special sterilizer. The switch box must be installed with a three-phase switch (or circuit breaker) and an overcurrent protection device to realize the function of power on/off and overcurrent protection of the equipment. Specialty equipment is wired in accordance with actual contract requirements for power supply. In order to ensure the safety of persons and equipment, a ground wire must be laid, and the ground wire in the equipment enclosure and control cable must be reliably connected to the external ground.

