



THERAPIC 9200-9400

Manuale d'uso | User's manual | Mode d'emploi
Gebrauchsanleitungen | Manual de instrucciones
Руководство по эксплуатации



INDEX	
INFORMATION ON THIS MANUAL	1
WRITING CONVENTIONS	1
WARRANTY	2
! WARNING !	4
INTRODUCTION OF THE TECNOLOGY	5
IONOPHORESIS	6
IN GENERAL	7
INTENDED USE	8
INDICATIONS	8
CONTRA-INDICATIONS.....	8
Relative contra-indications.....	9
PRELIMINARY NOTES	9
UNPACKING	9
SETTING UP.....	9
ACCESSORIES	10
CONNECTIONS.....	10
DESCRIPTION OF THE EQUIPMENT	11
ANTERIOR PANEL.....	12
REAR PANEL.....	12
HOW TO USE OF THE DEVICE	13
BEST USE.....	13
SETTINGS	14
VARIOUS	14
LANGUAGE.....	15
ELECTRODE TEST.....	15
LOADING PROGRAMS FROM MAIN MEMORY	16
HOW TO LOAD A PROGRAM FROM THE USER MEMORY.....	17
How to load a program.....	17
How to load a sequence	18
How to load and I/T curve	19
How to load values of rheobase and chronaxie of a selected program.....	19
HOW TO LOAD PROGRAMS FROM THE SMART CARD	20
CREATE PROGRAMS	20
How to create a program.....	20
How to create a sequence	22
How to create an I/t curve.....	23
How to extract rheobase and chronaxie values.....	24
COMBINED USE	25
ULTRASOUNDS.....	25
MAINTENANCE	26
TECHNICAL PROBLEMS	26
ELECTROMAGNETIC INTERFERENCES	26
TROUBLESHOOTING CHART	27
TECHNICAL FEATURES	28
APPENDICES	28
Appendix A - ENVIRONMENTAL CONSIDERATIONS	28
Appendix B – LABELS.....	29
Appendix C – LIST OF THERAPEUTIC SUGGESTIONS	30
Appendix D – WAVEFORMS	35
Appendix E – ELECTRO-MAGNETIC COMPATIBILITY TABLES	39

INFORMATION ON THIS MANUAL

This manual is addressed to:

- user of the machine;
- owner;
- responsible;
- people in charge of moving;
- installers;
- users;
- people in charge of maintenance.

This document provides valuable information regarding the installation, set up and use of THERAPIC-series equipment.

It is a useful and essential reference guide for the user: read the contents of the manual carefully before installing the equipment and keep it on hand at all times for future reference.

It is of vital importance that you strictly adhere to the recommendations contained within the manual in order to avoid malfunction, which may cause damage to the equipment and consequent annulment of the validity of the warranty.

Furthermore, in order to obtain the highly efficient technical service available from the manufacturer, it is essential that any handling of the equipment be in accordance with the instructions provided.

The limits of this manual are:

- the user manual cannot replace proper experience;
- the user manual, for particularly difficult operations, can only be a reminder of the main operations.

The manual is to be considered part of the equipment and must be preserved for future reference until the decommissioning of equipment. The operating instructions must be available for consultation in the vicinity of the machine and properly stored.

This manual reflects the state of the art at the time of sale and cannot be considered inadequate because later updated based on new information. The manufacturer has the right to update products and manuals without necessarily updating preceding

products or manuals, unless these have no implications for the safety of the device.

The company will not assume any responsibility for any major cases:

- improper use of the machine;
- use against to specific national regulations;
- incorrect installation;
- defects in power;
- serious shortcomings in maintenance;
- changes and unauthorized interventions;
- use of parts or materials not specific to the model;
- total or partial non-observance of the instructions;
- exceptional events.

If you would like any further information, please get directly in touch with the company EME srl, to stay up to date on the best ways to use these machines and to receive the necessary assistance.

WRITING CONVENTIONS

Certain sections of the manual have been underlined in order to highlight their importance.

NOTE

These contain important information and useful tips for operating the equipment

CAUTIONS

The CAUTION message appears before operations, which, if not correctly performed, may cause damage to the machine and/or its accessories.

! WARNING !

This signals operations or situations, which, if unknown to the operator, or incorrectly carried out, may harm the operator.

WARRANTY

EME srl guarantees the quality of its products for a period of 24 months from the date of purchase, when information contained in this manual regarding installation, use and maintenance is strictly adhered to and the warranty coupon is returned within 15 days of purchase.

The guarantee covers the replacement of faulty parts.

The warranty does not however, include the replacement of the equipment.

The warranty does not cover any malfunction or damage caused by:

- incorrect connection and installation;
- incorrect use due to non-compliance with instructions contained in this manual;
- use of the machine in environmental conditions which do not conform with those specified for the product;
- improper or inadequate maintenance;
- unauthorized opening of the outer casing;
- tampering or unauthorized modifications;
- use of non-original accessories.

EME srl registered offices provide the warranty.

Should you need to return the goods then please note the packing instructions as follows. Enclose a copy of the purchasing receipt.

You should insure the postal package.

Before sending the machine back for suspected malfunction, we recommend that first you carefully consult sections regarding MAINTENANCE and TROUBLESHOOTING of the manual, as a large part of the problems and faults are usually due to inadequate maintenance or small technical problems which can often be easily solved by the user himself.

A simple call to EME srl technical department may prove to be the solution to the problem .

When re-packing the equipment for return to the manufacturer, proceed as follows:

1. unplug the machine and any connections, devices, applicators etc;

2. carefully clean and disinfect all parts of the machine and accessories which have been in contact with patients.

Any equipment which the technical department does not consider hygienic (Italian law T.U.S. 81/2008 on safety in the workplace) will not be accepted;

3. disassemble accessories and any mechanical supports;
4. use original box and packing materials;
5. enclose detailed information regarding the nature of the problem in order to facilitate the technical department's intervention and save time on repair.

NOTES

PRELIMINARY NOTES

- The installation of the device does not require any special care, is therefore simple and immediate.

USE

- Each time you click the START button or the STOP button the machine will emit a long confirmation beep.
- Each time you select the SMART-CARD will take a few seconds to allow the machine to recognize and load the card: meanwhile it shows the message PLEASE WAIT.
- The selection of the SMART-CARD is possible only if previously inserted into the slot.
- To prevent erasure or formatting of SMART CARD, confirmation is required.
- To navigate the software it is necessary to use the encoder knob that can: rotate (both clockwise and anticlockwise) by moving the selection of an option, or confirm the selection by pressing the knob itself.
- The keys shown on the display are touch.

MAINTENANCE

- For an optimal use of the device and to guarantee its maximum performance, it is recommended to perform maintenance at the correct time and suggested ways.
- It's advisable to switch periodically the polarity according to the way it is connected to the applicator plates : the exchange will increase its durability.

CAUTIONS

PRELIMINARY NOTES

- The customer is liable for all damage caused by inadequate packaging of the material. Keep the original packaging of the unit: it will be needed if the unit is returned to the company.
- Do not use the equipment in places where it might get wet.
- Before operating the machine carefully check the correctness of the connections according to the instructions.

- To avoid the risk of electric shock, this device must only be connected to power supply networks with protective earth.
- Do not use accessories other than the ones provided: they might damage the unit, causing the warranty to become void. In case you have any problems or difficulties with installation, contact EME srl technical support.
- If using the same extension for the unit and other units, make sure that the total current being absorbed by the connected units, does not exceed the max current allowed for that type of cable and that, however, it does not exceed 15 A.
- The therapeutic suggestions are stored in the permanent memory of the machine. These protocols can be edited but not possible to save any changes.
- The protocols of therapeutic suggestion preloaded on the machine cannot be deleted.
- It is not possible to define a number of sessions suggested to evaluate the effectiveness of the treatment, since they are related to the power delivered to the patient undergoing treatment. E 'task of the physician to decide the number of therapy sessions which subject the patient according to the specific requirements of the case, in order to ensure to the patient himself the execution of an effective treatment in time and place in conditions of absolute safety.
- Always control sometimes the integrity of the cable and of the probe/applicator connector: they must not be damaged or worn.
- It's a class B machine in terms of emission. The EM device is suitable to be used in every environment, including domestic ones and those directly connected to a public network power of low voltage which supplies buildings used for domestic purposes.
- Do not use the machine near HF SURGERY DEVICES and rooms with an RF shield of an EM system for magnetic resonance, in which the intensity of the EM DISORDERS is high.
- No modification of this device is allowed.
- The use of accessories, transducers and cables, other than those specified or supplied by EME srl, could lead to higher electromagnetic emissions or a decrease in the level of electromagnetic immunity of the appliance, with consequent incorrect operation.

USE

- The Smart Card has to be introduced keeping the golden chip facing up
- A new **Smart- Card** has to be initialized using **FORMATTING** before being used.
- In case of selection of this type of memory if the card is introduced in wrong way or is not formatted or results not correct, a warning window will appear with the information about the error. Close the window clicking OK to continue.
- SMART-CARD option is visible (and therefore selectable) only if the smart-card is properly inserted in its slot. In case of lacked insertion of the Smart-card in its slot or Improper insertion, the option button SMART CARD is not visible, for which a possible selection does not involve any action.
- The selection of programs to be loaded takes place by default in the user memory, that in cases of non-presence of the Smart-card (due to its lack or to an improper insertion in its slot) is the only support of available memory to load customized programs.
- For the safety issue relating to the generation of the waveform will occur only if the self-test safety is positively exceeded
- In the "CURVE I / t" the electrodes must be placed in the same position in which they are applied for the normal delivery of electrotherapy

- Before proceeding with the curve I / t is necessary to format the secondary storage (Smart-card user memory) where you want to store
- For a successful login to the curve I / t is essential that all channels, including the channel No. 1, they are all free.
- Use only the power cord Link that is included with the machine for a combined use. It is strictly forbidden to connect to the ends of Link cable other machines than those specified. EME srl will not be responsible for any damage if used in a different manner from that stated.
- Avoid the application of stimulation on or through the head, directly on the eyes, including the mouth, on the front of the neck, (especially the carotid sinus), or electrodes placed on the chest and upper back or crossing the heart.
- On request we can provide the user manual in electronic form.
- Because of security reasons, the only specific software must be loaded into each machine. In case of exchange of software, the machine may immediately stop all its functions, requiring the intervention of EME srl technical assistance.
- The appliance or the system must not be used near other equipment and, if it is necessary to use it near other equipment, the medical electrical equipment must be observed to check normal operation in the configuration in which it is used.
- If the electro-medical device, interacting with another device, causes or receives detectable interferences, the user is invited to limit the interference by adopting one or more of the following measures:
 - o Reorient or reposition the receiving device;
 - o Increase the distance between the devices;
 - o Connect the equipment to a scale of a circuit different from or to devices that cause interference;
 - o Contact the manufacturer or local technician for assistance.
- Portable and mobile radiocommunication devices can affect the operation of the device.
- transportable RF communication equipment (including peripherals such as antenna cables and external antennas) should be used at a distance not less than 30 cm (12 inches) from any part of the device, including the specified cables. Otherwise, the performance of this device may be degraded.

MAINTENANCE

- Use the probes/applicators with care: any misuse may affect their performance and features.
- Under no circumstances technicians not authorized by EME srl are allowed to open and/or disassemble the probe/applicator: such tampering, besides damaging its characteristics, immediately invalidate the right to warranty.
- The equipment should never be disassembled for cleaning or inspection purposes: the units does not have to be cleaned internally, and if for some reason the unit must be opened, it should only be done by specialized technicians authorized by EME srl.
- Do not use thinners, detergents, acid solutions, aggressive solutions or flammable liquids to clean the external parts of the unit and accessories. Using these substances, or misusing the accessories, will cause the immediate voiding of all warranty rights, as well as irreparably damaging the unit and the accessories.

- For optimal use of the apparatus and to ensure its optimum performances it is recommended to perform properly within the time and in the manner recommended maintenance actions.
- For a correct replacement of the installed fuses, observe the following indications:
 1. disconnect the power supply and open the fuse box using a screwdriver, making sure you insert the screwdriver in the slot on the fuse box and levering up outwards;
 2. insert a screwdriver into the two side holes for fuse expulsion
 3. remove the old fuses
 4. insert a new fuse at a time by using a slight pressure to the left, with a finger
 5. push the box back to fit into the slot.
- It is recommended to perform periodic maintenance every two years, in order to check:
 - o the intensity of any leakage currents;
 - o the continuity and thus the integrity, of the ground conductor;
 - o the correctness of the value of insulation resistance;

in order to ensure the electrical safety of the device, ensure that it is operating in a safe guaranteed. For this kind of intervention you should contact a qualified service technician or alternatively EME srl or one of its authorized service centers.

WORKING PROBLEMS

- Only technicians authorized by the manufacturer may access the interior of the unit. You should contact EME srl or its authorized service centers for any repair work or further information.

! WARNING !

PRELIMINARY NOTES

- The correct position while moving the machine: the apparatus has to be moved exclusively by gripping it with both hands on the curved profiles of the lid.
- The perfect functionality of the device is guaranteed in accordance with the rules of installation and of use included, only with original accessories and spare parts.
- If there are problems or installation difficulties, please contact the EME srl technical assistance department.
- Before connecting the cable to the mains plug, check that the equipment wasn't damaged during transport. Ensure that the power supply specifications on the mains socket correspond with the information on the label attached to the back of the unit.
- The electric current that powers the unit is VERY DANGEROUS. Before connecting or disconnecting the power cable from the connector on the unit, make sure it is plugged out from the mains socket.
- The power cable has an earthed plug for safety reasons.
- Only use with a mains socket suitable for use with earthed systems
- **The equipment should only be connected to electrical systems that fully comply with regulations.**
- If using extension cords verify the presence and the integrity of the protective conductor to earth.

- Connect the equipment directly to the wall socket without using extensions. Failure to comply with these warnings may result in dangerous electrical discharges that could cause injury operators and compromise the functioning of the unit.
- Patients with implanted electronic devices (i.e. pacemakers should not be subjected to electrotherapy without the consent of the physician.
- The application of electrodes in the chest area may increase the risk of cardiac fibrillation.
- Avoid use in areas where there are ongoing inflammatory processes.
- Simultaneous connection of a patient to a unit of high frequency electro-surgery can lead to burns and damage the unit of electrotherapy.
- Working in the neighbourhood of a short-wave or a microwave equipment may produce instability in the output of electrotherapy.
- The manufacturer is held responsible for the fundamental safety, reliability and performance of the device only if:
 - o The electrical system of the premises complies with the appropriate regulations;
 - o The device is used in accordance with the instructions for use.

USE

- In order to avoid the contamination of the environment where the machines are working and/or the people involved in its use, do not apply to patients electrodes already used in other appliances.
- In order to avoid increases in the level of current delivered out of control, the software monitors the current circulation, the patient circuit is then monitored and in the event of removal from the electrodes' connection, the therapeutic treatment is interrupted.
- The electro-therapy treatments must be provided under the strict control of the operator to "conscious" patient who are able to interact with the operator concerning the electrical stress produced by the machine.
- Some electro-therapy treatments have a high average value current, which make the treatment inherently dangerous as it may occur temporary redness and muscle blocks.
- The advanced termination of a therapy session should be done only by the key Do not remove the plug from the wall outlet 230V, do not unplug the power cord or using the bipolar switch On/OFF.
- Moreover it is necessary to remove first the electrodes from the patient's body and then you can proceed with the turning off.
- Use special care in the arrangement of electrodes and in the delivered current when associated to a continuous component (Ionophoresis).
- Use particular attention in the arrangement of electrodes with a current density superior to 2mA/cm² (right value for efficacy. When using galvanic currents (Ionophoresis) do not exceeded for any electrode current density of 0,2mA/cm².
- Do not use electrodes in direct contact with the skin, use special moistened sponges.
- Communicate to the patient to alert the operator in case of the intensity of the supplied current causes discomfort.
- In order to ensure the functioning of the machine in conditions of absolute safety for the patient, the operator must pay attention to the necessity of a periodic maintenance (every 2 years) of the equipment. EME srl authorized personnel should carry out such operations.

- It is absolutely forbidden the use of the device in the presence of a flammable anesthetic mixture and oxygen-rich environments. In case of non-compliance with this indication, EME srl will not be responsible for any accidents.
- It is absolutely forbidden to cover the ventilation slots: such an action may not allow the machine to work in safe conditions. In case of non-compliance with this indication, EME srl will not be responsible for any accidents.
- It's important to pay the attention of the operator to the necessity to verify the correctness of the electric installation of device before activating the supply switch.
- It is advisable to suspend the therapeutic treatment if it were to appear some disturbances during its emission.
- It's strongly advised not to hold the device on in state of start without using the probe, it could overheat.
- If the button OK is pressed to confirm the software updating before having connected the USB-port to the source containing the software updating, the device goes out from the main program and enters in the updating routine waiting for the USB connection. A screen indicates the missed connection. If the support to connect to carry out the updating is not available, it is necessary to switch off the device and turn it on again through the general switch to restart the device with the available software.

MAINTENANCE

- The electrode is considered a commodity . It is necessary to replace electrodes periodically every 2-3 months in conditions of normal use : an electrode has a duration of hundreds of milliamperes/hour.
- The use of depleted electrodes reduces the performance of the machine and can cause burns.
- For safety reasons before carrying out any maintenance or cleaning the unit, YOU MUST turn off the equipment with the power switch at the back and unplug the socket connected to the mains.
- Before every treatment, it is recommended to clean with caution all of the accessories and the parts of the equipment that have been to contact with the patient.
- The operator must pay attention to the necessity of a periodic maintenance (every 2 years) of the probes/applicators. EME srl authorized personnel should carry out such operations.
- The cleaning and disinfection must be done systematically before the therapeutic treatment which subject the patient.
- Do not use thinners, detergents, acid solutions, harsh solutions or flammable liquids to clean the outside of the unit and its accessories. The use of these substances, with the improper use of accessories, irreparably damages the equipment and the warranty will lapse.
- Always control sometimes the integrity of the cable and of the probe/applicator connector: they must not be damaged or worn.
- It is advised that personnel with technical preparation substitute the fuses, to perform the operation in safety conditions.
- Do not open the device: inside there are high voltages that may be hazardous.
- Only personnel authorized by the manufacturer may access the internal components. For repairs and further information please contact EME srl or its authorized service centers.

WORKING PROBLEMS

- Do NOT OPEN the unity, as HIGH VOLTAGE ELECTRICITY is present and may prove VERY DANGEROUS.

INTRODUCTION OF THE TECNOLOGY

Electrotherapy is used in order to stimulate denervated muscle, to reduce the hypotrophy due to the non-use of the muscle normal-innervated, to maintain the muscular trophism of the denervated muscle or partially innervated, to strengthen the innervated muscle.

Electrotherapy uses the biological effects obtained by electrical Energy for therapeutic purposes and consists of electric currents which are passed through the part of the body concerned, taking care to choose them with certain characteristics suitable to the aims to be achieved. The electric currents can be continuous or variable.

The continuous current (or Galvanic current) is generated by the uniform movement of electric charges in the same direction. Therefore it has constant intensity over time.

Any action produced on an organism by this type of current is effectively linked to the electrochemical effect. If you immerse the electrodes of a galvanic current generator into an electrolyte solution, the ions will flow towards the poles of the opposite sign.

From the point of view of electricity, the human body behaves like an electrolyte solution: ions naturally present in the organism 'migrate' in the presence of an electric field.

Their distribution in cellular and extracellular spaces is variable, and so the potential and permeability of cell walls change.

These phenomenon give rise to a series of effects that can be summarised as follows :

- vasomotor: strong hyperthermia may be felt in the area where the current is applied, even after a brief treatment session;
- trophic: improvement in cellular 'breathing' due to greater blood flow that stimulates the metabolic processes;
- anti-oedematigenous and anti-inflammatory: linked to the reabsorption of exudatives and inflammatory substances;

- nervous: the excitability is increased near the negative pole, and lessened near the positive pole ('polar' effect of the current).

This phenomenon regards the resting electric potential of the membrane that surrounds the nervous fibre. The external surface of the membrane is positively charged with respect to the internal surface.

Contact with the negative pole leads to depolarisation of the membrane, while the positive pole is hyperpolarised.

Even the conductivity of the nerve is changed during passage of the direct current. Temporary neuropraxia may occur at the positive pole.

It is quite difficult to correctly interpret the effects caused by the direct current however since the mechanisms that determine them are not fully understood.

This kind of current serves best as a transcutaneous carrier of medicines or cosmetically active substances.

Variable currents are generally meant to denote all those currents where the intensity is not constant over time.

Alternating current belongs to this category: it varies in intensity, and also periodically alternates in direction: the classic sinusoidal current belongs to the category and the time that the current takes to make a complete sinusoid is called the period. The space covered during the period is the wavelength. The number of periods made by the current in a second defines the frequency and its unit of measurement is the Hertz [Hz]. We can distinguish between low (0 - 800Hz), medium (800 - 60.000Hz), and high frequency currents (above the 100.000Hz), and for physiotherapy purposes.

All these currents have some properties in common as regards their application effects: the most important biological effect is definitely the motor neuronal excitability effect.

In order to avoid the risk of possible muscular adjustment during contraction, some equipment can supply currents that automatically vary their frequency at regular intervals.

The rectangular currents that operate at 50 Hz frequency with 1msec pulse duration are of special importance as they produce analgesic effects.

The so called "ionic acceleration" is also beneficial as it involves an overlapping of galvanic current with a rectangular current. This device allows us to obtain parallel muscular stimulation during the iontophoretic delivery (normally done by applying

the current with constant intensity). Treatment time is markedly reduced when this method is used.

The different types of currents can be summarised according to their specific actions (or biological effects):

- Currents at IONTOPHORETIC action = continuous current (at constant intensity);

- Currents at EXCITO-MOTOR action = sinusoidal currents, rectangular exponential currents, pulse train, triangular

- Currents at ANTALGIC action = rectangular pulses of low frequency (50Hz) and pulse time 1msec.

- Currents at TROFIC and VASCULARISING = continuous currents; straightened currents.

IONOPHORESIS

Current thinking confirms that ionophoresis is an effective way of administering different substances when localised action is required.

Actually, the percutaneous application of medicinal substances is notably affected by the barrier function of the corneal stratum. Methods generally used to neutralise this effect are not always effective.

Overcoming the cutaneous "barrier" stratum is not easy even when direct current is used, since substances generally prefer to enter via the glandular ducts and hair channels.

In addition, the substances can only reach a few millimetres depth.

Excluding the cases where a localised surface effect only is required, the effectiveness and distinctiveness of ionophoresis lies in the fact that the substances introduced in this fashion seem to bind more stably with proteins that normally form part of surface tissue. The substance is therefore reabsorbed into the general cycle more slowly than it would have been if administered hypodermically.

The general effect is however linked with the type of substance used: direct current only functions as a medium.

Therefore medicinal ionophoresis refers to substances introduced that have pharmacological effects.

The substances that can be used are all those with the following properties: a constant percentage of ionic disassociation in water, stability in solution and in contact with electric currents .

However, certain basic rules must be remembered :

- any *water* used to put the substance into solution must be *distilled* to avoid preferential transport of parasite ions;
- *sponges and electrodes* must always be kept perfectly clean and they must be washed well in distilled water;
- if an active substance solution must be prepared on the spot, the concentration of solution must be correctly chosen and measured (remember that it is unnecessary to use high concentrations: generally 1% in weight is easily enough for most substances);
- if products contained in vials are used (for parenteral use) ensure that there are no products incompatible with the technique among the excipients. If it is a freeze-dried product, ensure that the solvent is not a physiological solution: in that case use distilled water if possible;
- avoid including other substances unless you are sure that they are perfectly compatible: if you consider the substance to be essential, ensure that it has the same polarity;
- the correct *electrode* arrangement is essential for diffusion of the substance, especially if the molecular weight is low;

If you have to introduce a positive ion, it must be put with a positive electrode and vice versa for negative ions (in the case of complex molecules on the other hand, it seems that electro-osmosis (and also electrophoresis) takes priority: therefore the concept of polarity loses meaning, and penetration is more effective if done at anode level; the polarities of the most commonly used medicinal substances are described in another section).

Even though the dosage of medicine to introduce is significant from a theoretical point of view, it is actually related to too many factors (skin resistance, ion size, electrode placement) to make even an approximate calculation.

The use of galvanic current to the introduction of substances, when the parameters of current intensity and duration of application are respected ,does not give rise to undesirable effects on the skin.

Localized redness may occur occasionally, and even burns, but only when these parameters are not met, or there is a lack of maintenance or improvement of electrodes. Chemical burns at the points of contact of the skin with the electrodes, due to concentrations of chlorine ions and/or sodium (for formation of caustics substances with water) may occur when using water source.

There is the possibility of local allergic reactions, although relatively uncommon : in any case, events are mild. Systemic allergic reactions must be excluded.

IN GENERAL

EME srl has recently developed a complete series of apparatus, accessories and equipment, designed and manufactured according to the highest standards of quality, making use of the latest technology and fully adhering to current directives and norms.

Particular attention has been paid to the design, easy operation, function and safety of the equipment and the final result is this modern, compact unit, which offers an extremely logical operative sequence supported by a clearly legible display .

A wide range of therapeutic applications, and guaranteed patient and therapist safety ensure that equipment is of the highest quality.

The equipment were planned and built in manner that their use, if it happens at the conditions indicated, doesn't compromise the health and safety of the patients, of the users and of third, taking into consideration the benefit to the patient.

Such equipment are not bound to diagnosis, prevention, monitoring, compensation of injury or handicap, substitution or modification of the anatomy, control of the conception, support/vital support of functions but allow to treat special pathologies and to reduce the illness.

A special intervention is not required in the event of failure of the medical device, but just a normal maintenance/repair.

INTENDED USE

THERAPIC-series is an electro-medical device that delivers electrotherapy treatments, with the application to the patients of conductive electrodes.

The use of these equipments is reserved for operators, such as physiatrists, physiotherapists and pain therapists, that, by their training, provide assurance of proper use and safe for the patient.

In fact, the operator must be appropriately qualified and he carefully studied the contents of the user manual in order to use the device; or, he must operate under the supervision of a health professional adequately qualified to use the machine, able to understand the benefits and the limits of therapy and to work in conditions of safety for the person undergoing treatment.

Such equipment can be used in hospital environment outpatient, nevertheless, it is important to know that the user follow the medical instructions to use the equipment or that he follow the indications present in the user's manual.

The U.S. Food and Drug Administration (FDA) has issued several guide documents for medical equipment and has provided the following guidelines for the use of equipment for muscle stimulation:

- relaxation of spastic muscles;
- prevention of disuse atrophy;
- increase local blood circulation;
- provide for muscle reeducation;
- provide immediate post-surgical stimulation of calf muscles to prevent venous thrombosis;
- maintain or increase range of motion.

INDICATIONS

Main effects of electrostimulation:

1. Training of the neuromuscular system to respond appropriately during the voluntary and involuntary effort providing an active contraction (isometric, concentric and eccentric) and the resulting joint movements allowing a proprioceptive feedback;
2. Modulation of pain by the gate control mechanism or mechanisms of descending inhibition;
3. Control or reduction of spasticity by agonist stimulation (contraction/relaxation), antagonists (reciprocal inhibition) or motor inhibition sense;
4. provide to the trans-dermal release of medicinal substances into the skin (ionophoresis);
5. Improve or maintain joint mobility through mechanical stretching of muscles or connective tissue or reduction of the impediment of movement caused by neuromuscular dysfunction, pain or swelling;
6. Promote wound healing by increasing local circulation, providing a bactericidal effect or alternating electric charges in the injured area.
7. Delay or resolving edema through muscle pump or the effect of electric charges on the interstitial proteins (phenomenon of magnetic fields).

CONTRA-INDICATIONS

1. Applications on thoracic region in patients with : arrhythmias, congestive heart failure, recent myocardial infarction or other cardiac abnormalities;
2. Application in any region of the body in people with active implantable devices;
3. Application on the area of carotid sinus (the bifurcation of the common carotid artery);, as it may interfere with the normal regulation of the pressure blood flow and cardiac contractily;
4. Trans brain applications, because it can affect neural function (however in some situations the micro-currents are today applied in the trans-brain way)
5. Application on pregnant uterus;
6. Application on cancer tissues (malignant);

7. High width application directly above areas where it is localized the bone tissue on surface , a sit can cause periosteal pain;
8. Application in damaged area or irritated skin because the current preferentially penetrates through the irritated area causing discomfort (however some types of E-stim are used to promote the healing of wounds);
9. Application with electrodes near or touching protruding metal, such as surgical staples or sutures;
10. Application on patient who reacts negatively to the procedure;
11. Application on patients who cannot provide with a suitable reaction on stimulation level (Children, children with mental disorders).

Relative contra-indications

12. On areas of excessive fatty tissue when the high level of stimulation, required to activate the deep structures can cause pain or independent reactions;
13. on the phrenic nerve region or on urinary bladder as the stimulus can interfere with the normal function of there structures;
14. on scars because the scar tissue has an increased electrical resistance ;
15. The current acts preferencely around the scar causing an increase of current density at the scars' edges with possible creation of burnings.

PRELIMINARY NOTES

UNPACKING

The equipment THERAPIC-series is specially packaged for transport in a single pack complete with filling which has been specifically studied for safe transportation and storage.

To remove the equipment from the pack, place the box on a smooth, flat surface. Open the top of the box and remove the polystyrene filling. Be very careful when removing the contents of the pack.

The unit and accessories are wrapped in transparent sheets of polyethylene protection and contains the following:

- the User Manual;
- n.1 mains power supply cable;

- n.2 spare fuses (see technical specifications);
- conductive rubber electrodes 6x8.5 cm;
- conductive rubber electrodes 5x5 cm;
- sponge for big electrodes;
- sponge for small electrodes;
- elastic bands length 100cm;
- elastic bands length 60cm;
- n.1 Output cables for electrotherapy;

Check the contents of the package and should any of the items be missing then contact your local authorized EME srl dealer.

SETTING UP

Installation of the electrotherapy equipment THERAPIC-series is fast and simple.

The following environmental conditions are ideal when installing the equipment:

- room temperature: from +10° to +40°C;
- humidity level: from 10% to 80% without condensation;
- avoid direct exposure to sunlight, chemical products and vibrations;
- avoid using RF wireless communication devices in proximity (<0.30m).

ACCESSORIES

The device can be used with the following accessories:

Number (for each output)	Description	Included	Optional
1	Power cable plug shuko	X	
1	Spare Fuses	X	
1	User manual	X	
4	Sponge for electrodes 5 x 5cm	X	
4	Sponge for electrodes 6 x 8.5cm	X	
2	Short elastic bands (60x5cm)	X	
2	Long elastic bands (100x5cm)	X	
4	Conductive rubber electrodes 5x5cm	X	
4	Conductive rubber electrodes 6x8.5cm	X	
1	Output cables for electrotherapy with banana cables of 2mm	X	
	Output cables for 2 channels (CH1-2)		X
	Output cables for 2 channels (CH3-4)		X
	Output cables for 2 channels (CH1-2 / CH3-4)		X
	Conductive rubber electrodes 5x5cm		X
	Conductive rubber electrodes 6x8.5cm		X
	Sponge for electrodes 5 x 5cm		X
	Sponge for electrodes 6 x 8.5cm		X
	Short elastic bands (60x5cm)		
	Long elastic bands (100x5cm)		
	LINK cable for combined use of electrotherapy/ultrasound devices		X
	Smart Card		X

The ACCESSORIES that can be replaced by the RESPONSIBLE ORGANIZATION and that can influence the conformity of the EM EQUIPMENT:

Two-pole cable for electrode connection. The cable length must be less than 3m.

The accessory assembling is simple and intuitive : each cable for the therapy, that allows the connection of the output channels, is equipped with a multi-polar connector to be inserted in the plug on the front panel of the device and with two pairs of pins (red for the positive electrode and black for the negative one) for connection to the plates of conductive rubber of each channel.

The plate holder sponge's pockets have different sizes, each suitable to accommodate the corresponding electrode of conductive rubber.

Be sure of the proper insertion of the electrode into the sponge's pocket.

Along the side of each electrode in conductive rubber, there is a coupling plug in which the banana cable for electrotherapy coming from the equipment must be connected.

Contact authorised dealers EME srl for problems or difficulty installation.

CONNECTIONS

The power entry module can be found on the back of the unit and consists of a three-pole socket for the cable set, an extractible fuse box with two fuses (see technical specifications) and the main switch.

Plug the power supply cable three-pin plug into the integrated board and ensure that it is correctly plugged into the connector.

When using an extension lead, make sure that it has been earthed.

Failure to comply with the above instructions may lead to dangerous electrical discharge causing machine damage and harm to persons.

Once you have checked that installation and assembly have been carried out according to instructions provided up to this point in the manual, switch on the machine making sure that the display screen is turned on correctly.

DESCRIPTION OF THE EQUIPMENT

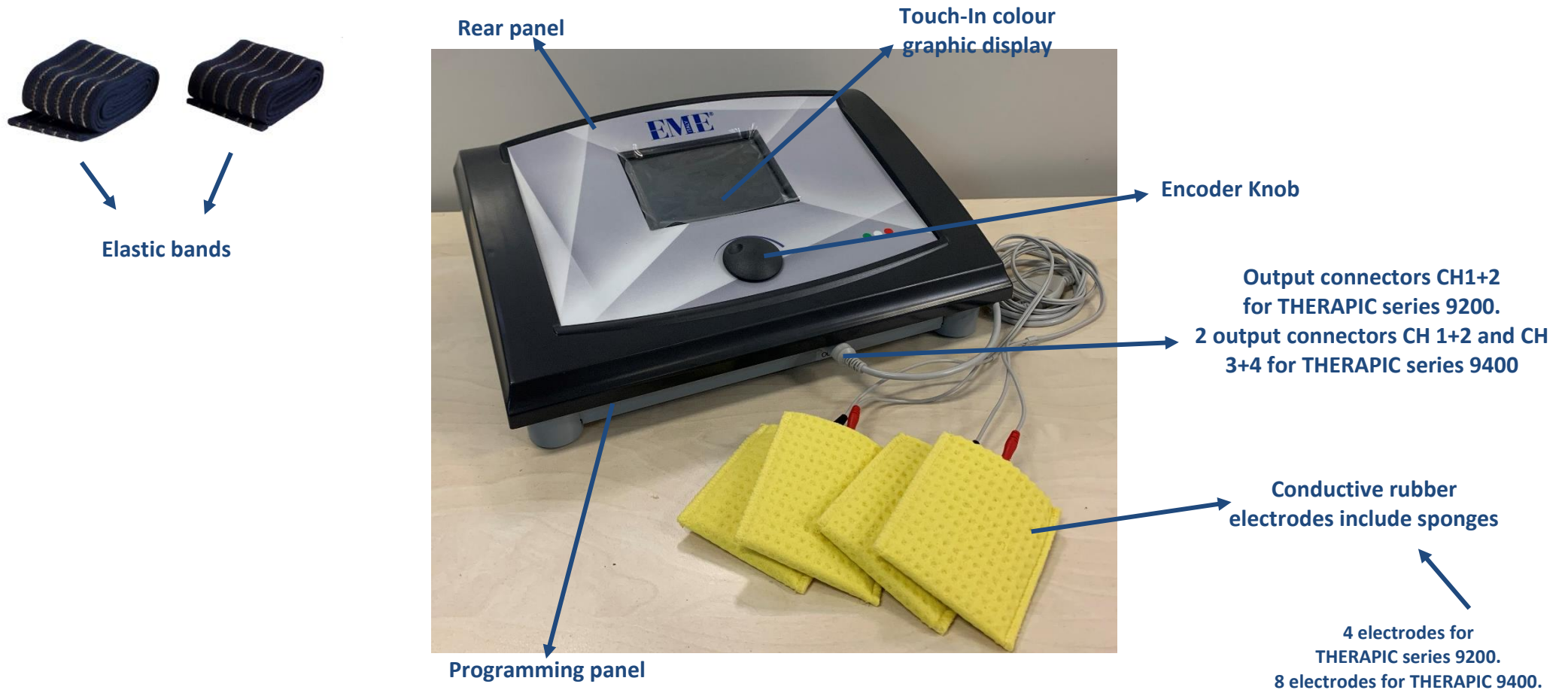

Models of THERAPIC	THERAPIC 9200	THERAPIC 9400
Hallmarks of unit		
Number of waveforms	25 waveforms (low and medium frequency)	25 waveforms (low and medium frequency)
Delivery channels	2 independent channels with banana plugs 2mm	4 independent channels with banana plugs 2mm
Output connectors for serial connection	1 connector CH 1+2	2 connector CH 1+2 and CH3+4
Possibility of combined use	ULTRASONIC	ULTRASONIC

ANTERIOR PANEL

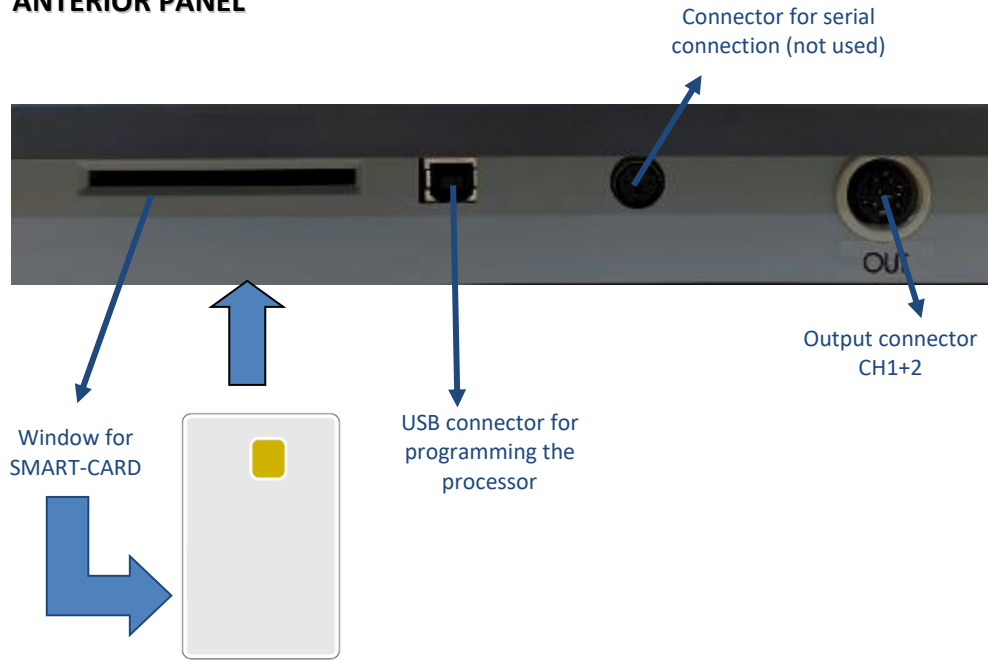

SMART-CARD

Note: in the model THERAPIC 9400 there are two output connectors (CH1+2 and CH3+4).

REAR PANEL

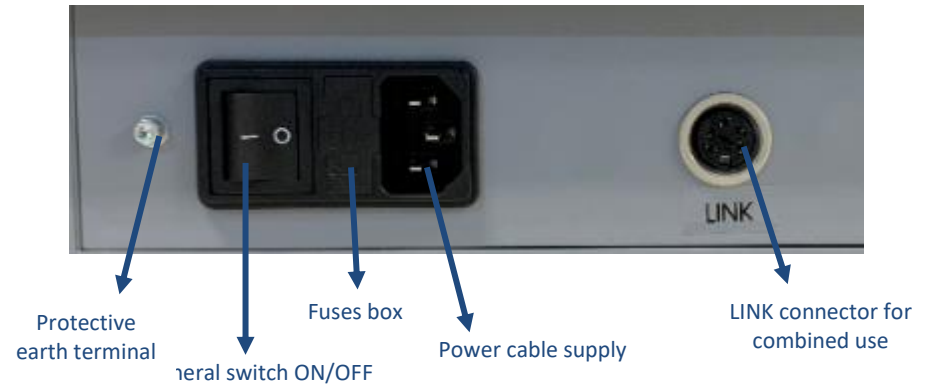

HOW TO USE OF THE DEVICE

This section provides important information and instructions on how to make the best use of the equipment for electrotherapy THERAPIC-series.

All the control functions and the machine itself are handled and co-ordinated by a microprocessor: apart from making pre-memorised programmes available for application, the microprocessor ensures that the machine can be personalised and operated in a highly safe and efficient manner.

Interfacing allows for the operator to communicate with the unit by means of a large, clear graphic backlit liquid crystal display screen (LCD) through which all operational messages required by the operator, work status during operation, and errors are visualised.

The following paragraphs illustrate the procedures to be carried out and the technical specifications of the unit.

They also deal with the different options available, from the selection of a pre-memorised programme for use in specific treatments as well as how to determine the correct working parameters for “personalised” applications.

BEST USE

After having installed and correctly positioned the machine as per the instructions described in the previous sections and the electrode applicator connection cable (or cables) has been connected with the right connectors, plug the machine into a 230Vac wall socket and switch on using the ON/OFF main switch on the back panel of the unit.

Once turned on, the LCD display lights up and the unit is ready for use.

With the first turn on the device, you can set the language between the six available. Then turn the encoder to select the desired language and press the knob to confirm the selection. Press the SAVE button to save the changes. A confirmation message will inform you of any such modification.

The LCD display will illuminate showing the logo (see Fig1). Appears the main screen that allows to select between four operating modes (Fig.2) by pressing the corresponding button.

If you want to use the Smart-Card to create new customised programmes or to run those already stored, insert it as shown in the Fig.3, with the chip facing upward.



Fig.1

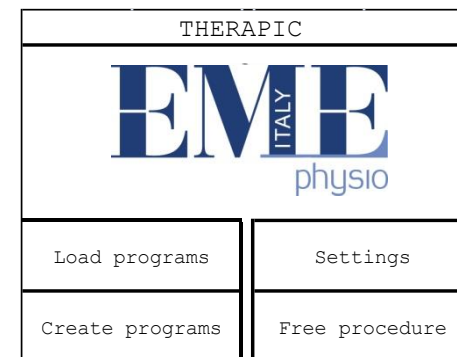

Fig.2

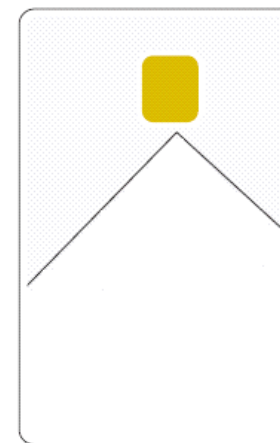

Fig.3 – SMART-CARD

SETTINGS

Allows you to edit and save to the internal memory the basic settings to be recalled automatically every time .

At the screen in fig.2 press SETTINGS: window appears fig.4

Turn the encoder knob (which by default is located on the OTHER menu) select the feature you want to change, and then press the knob to confirm the selection.

On the page also appear information about the version of software and firmware of each module of the power board installed on the machine, and COMPANY contacts

VARIOUS

By pressing the encoder knob at the menu VARIOUS: appear fig.5.

You can perform the following operations:

- turn on or turn off the horn,
- enable or disable the feature of electrodes,
- enable or disable the functionality of synchronization of the output channels, enabling the machine to provide the same therapeutic treatment on the output channels selected for synchronization (1+2, 3+4, 1+2+3+4).
- formatting the smart card or user memory of the machine which is equipped.

Formatting the smart-card is made when you insert a new card that has never been used. It can also can be used the function FORMAT SMART CARD to delete it completely, thus making it available, for example, for use on a different machine.

Selecting the option FORMAT SMART CARD through the rotation of the rotary encoder and the next press of the same once placed above this item, displays a screen where you are prompted for confirmation about what to do to avoid accidental formatting.

Pressing the function key on the EXIT button, the format operation is aborted and returns to the screen in fig.5.

To confirm the format operation, but press the function key for the button FORMAT.

If the smart card is not inserted correctly , it displays a message and the user is informed that the smart card is not inserted. The operation in not performed and returns to the screen in fig. 5.

Instead, in the case of correct insertion of the smart card in its slot, press the FORMAT button, the machine displays a message that informs the operator on the progression of the selected program, and when the operation is completed a message displayed and informs the user of the completion of the requested operation .

At the end of the formatting of the smart-card, you will return to the screen in fig.5.

The formatting of the user memory is performed in a similar manner to that of the smart-card, selecting the menu FORMAT MEM.UTENTE in place of the FORMAT menu SMART CARD.

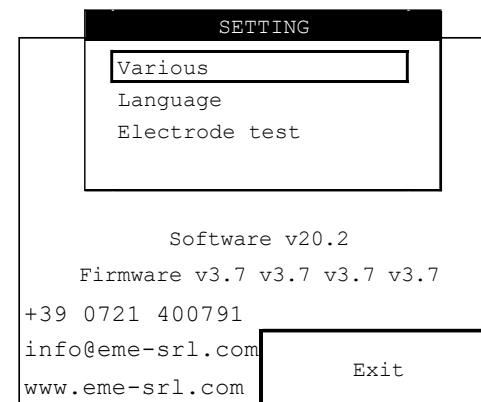

Fig.4

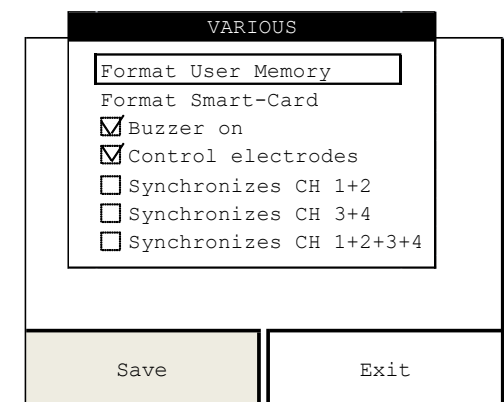

Fig.5

The control of the electrodes is enabled by checking the check box CONTROL ELECTRODE, this function allows you to check if the electrodes are properly connected to the machine.

This check is performed to therapy delivery in progress, and fails if one of the two conditions is not met. The operator is informed of the outcome of the inspection by the appearance of a message on the screen.

The control of the electrodes is not executable in the following conditions :

- for current intensity not exceeding to 10mA
- for too low pulse frequency
- for too short pulses duration
- in constant voltage modality

the configuration set can be saved by pressing the function key on the SAVE button (see Figure 5).

Pressing the EXIT function for the button (see Figure 5) to return to the main screen of the SETUP menu (Figure 4).

LANGUAGE

To choose the language in which you write all messages and commands of the machine, select the desired language by turning the encoder knob and press the knob to activate the new language choice.

The language can be selected from those available in Italian, English, French, German, Spanish, Russian and Romanian.

After a short pause for the loading of the new dictionary, the main screen of the SETUP menu with the new language.

To select the desired language, turn the encoder knob until you reach the appropriate line and press the encoder knob to confirm your selection, then press the SAVE button to enable the machine to work with the selected language.

Pressing the EXIT function for the button instead of the encoder knob to select the language, it goes back to the main screen of the SETTINGS menu (fig. 4)

To change the language back you can repeat the procedure at any time

ELECTRODE TEST

The electrodes' test is used to verify that the output boards are working properly.

Follow the instructions on the screen. After a short time in which the machine is performing, you will see a video message on the state of the electrodes:

- ELECTRODES OK
- ELECTRODES OUT

It is possible to change the display of the output channels, by pressing the button corresponding to the function CHANNEL 1.

The procedure is started by pressing the START button.

If you press the function key for the button EXIT, the screen returns to Fig. 4.

FREE PROCEDURE

In this section you can quickly change the parameters of treatment and arbitrary waveform so loaded and use them for your own program.

After pressing the key button PROCEDURE FREE a screen containing a waveform with the relevant technical data.

In this screen there are three buttons on the screen:

- button START to start loaded therapy
- CHANNEL 1 button, which allows you to select channels between the two treatment delivery available;
- the EXIT button, to return to the screen in fig.2

The cursor of the encoder knob is located on the default menu of the waveform. To change the type of waveform, press the encoder knob and turn until you find the desired shape, then press the encoder knob to confirm the selection.

Before starting treatment, you can customize the program by changing the time of duration of treatment and the values of its characteristic parameters: polarity reversal at mid-term and type of emission:

- the changes to the waveform are not storable
- changes to the treatment plan cannot be stored in main memory, but custom protocols can only be saved in the storage media secondary (user memory or smart cards)

Pressing the CHANNEL 1, you can select the channel at which to load the desired therapeutic treatment.

The button CHANNEL 1 indicates that the program has been uploaded refers precisely to channel 1 and then pressing the button toggles the selection of output channels available.

The channel in which the emission is already active is obviously not available for a new program until the previous one has not ended.

LOADING PROGRAMS

Pressing the LOAD PROGRAMS directly on the screen you can upload therapeutic programs contained in the machine or possibly those saved in the smart-card.

The main screen of the menu contains 4 buttons:

- button STANDARD PROGRAMS
- button USER PROGRAMS
- button SMART-CARD PROGRAMS
- button EXIT

and the list of protocols contained in the main memory of the machine, which is loaded by default when you select this menu.

The programs can be customized by the operator is stored on smart-card that the user memory, unlike what happens instead for the main memory.

Offered stored programs are the result of years of operational experience in user support professional experts. Appendix C contains a list of available programs.

The channel in which the emission is already active is obviously not available for a new program until it is finished. Press the EXIT button (directly on the screen), you return to the screen in fig. 2.

LOADING PROGRAMS FROM MAIN MEMORY

Pressing the STANDARD PROGRAMS, it can be load programs stored on the main memory of the machine (such programs are editable, and then customized by the operator, but cannot be stored on that media).

To select one of the treatments available, turn the key encoder to select the desired treatment, and then press the encoder knob to confirm the loading of the desired treatment

Once you choose the treatment that you want to deliver, a screen appears that contains the parameters that characterize the selected treatment

It could be changed:

- delivery time of treatment
- polarity
- mid-term inversion

- type of emission
- the pulse duration
- the type of pulse (variable between S, A and R, where S stands for Symmetric, A for Asymmetric and R for Rectangular
- The frequency
- the rise time
- The time of descent
- The time of permanence
- pause time

To change the value of one of the characterizing parameters among selected program follow the instructions below:

1. Turn the encoder knob into position of the cursor of parameter you want to change;
2. press the encoder knob ;
3. turn the encoder knob (clockwise for increasing values in an anti-clockwise to decreasing values) to select the desired value for the parameter that you want to customize;
4. press the encoder knob to confirm the assignment of the selected value to the custom parameter.

Repeat steps 1) to 4) for each of the parameters that you wish to modify.

Push the button START to start emission of the program.

Push the button EXIT to exit the menu: the software will get back to the main screen of the menu LOAD PROGRAMS.

If you push the button CHANNEL 1 you can select the channel where the treatment will be emitted to the patient. Repeatedly pressing this button, you can alternate the CHANNEL 1, 2 in the case of THERAPIC 9200 and CHANNEL 1, 2, 3,4 in the case of THERAPIC 9400.

HOW TO LOAD A PROGRAM FROM THE USER MEMORY

The user memory is one of the slave memory slots of the device. There you can store therapeutic programs, sequences of therapeutic programs, I/T curves and values of rheobase and chronaxie.

Before choosing one of the four options, you need to format the user memory, otherwise the device (when choosing an option) will show a message and emit an acoustic signal, requesting to format the memory slot.

Follow the instructions to load a menu:

1. Push the button that reads "USER PROGRAMS (pic.2);
2. Turn the encoder knob and choose the desired menu;
3. Push the encoder knob to confirm the choice.

How to load a program

Turn the encoder knob to select the menu PROGRAM, then push it to confirm the operation.

If the user memory does not contain programs, a message appears on the screen, with an acoustic signal, stating that there are no stored programs in the user memory. The system goes back to the screenshot in the main menu of the PROGRAM LOAD button.

If the user memory contains programs, the list of the stored programs appears on the screen. You will see a screen like in pic.7.

Push the button EXIT to cancel the loading procedure. The system will go back to in the main menu of the PROGRAM LOAD button. Otherwise push the encoder knob after highlighting the menu of the program you want to load; the screen as in pic.8 shall appear.

The stop loading push the button EXIT. The system will go back to the screen in pic.7.

To cancel the selected program push the button CANCEL. The list of the programs stored in the user memory will be updated. Instead, in order to load the selected program push the button LOAD.

After choosing the desired therapeutic treatment, the screen with all the parameters of the treatment chosen will appear (see pic.9). You can modify the treatment

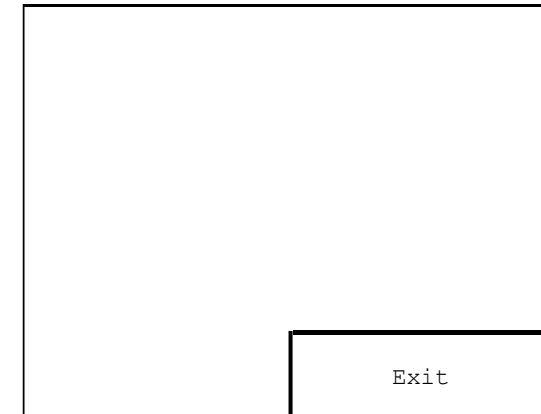

Fig.6

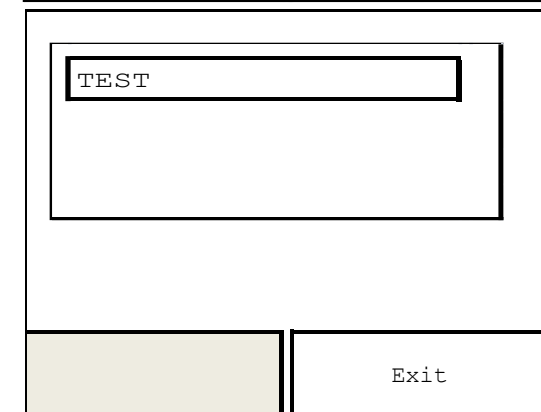

Fig.7

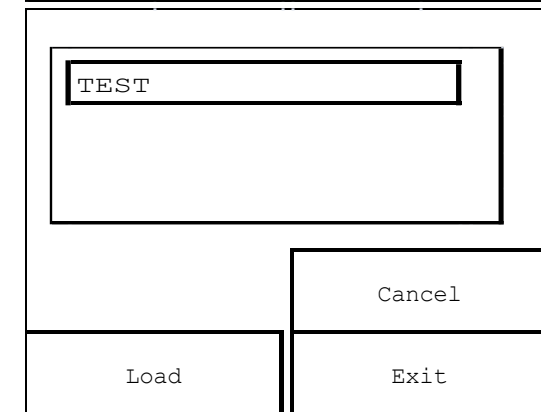

Fig.8

emission time, polarity, inversion halfway the period, type of emission, following the procedure described in HOW TO LOAD PROGRAMS FROM THE MAIN MEMORY.

You can choose the output channel, between the channels available (2 in the case of THERAPIC 9200 or 4 in the case of THERAPIC 9400), by pushing the button CHANNEL 1 in succession until the button reading the desired channel will show up.

To abort the execution of a program, push the button EXIT. The system will go back to the screen in pic.7.

To start a program push the button START: the screen in pic.10 shall appear.

The treatment emission is indicated by the counter that shows remaining time until the program comes to an end. The channel occupied by the emission is indicated by the number inside the button EXIT.

To pause the program push the button PAUSE (see pic.11): the counter stops and the screen will read PAUSE, the emission channel will be shown until you push again the button STOP in order to completely stop the emission of the desired program.

To resume emission, from the same channel, push the button START, while to terminate the emission push the button STOP.

You can also pause the treatment in one channel and start its emission in another available channel by pushing the button CHANNEL 1, that will be substituted by the button CHANNEL 2 (in the case of THERAPIC 9200) or by the button CHANNEL 3 and CHANNEL 4 (in the case of THERAPIC 9400): then push the button START. Inside the button EXIT another number indicating the channel occupied will appear.

How to load a sequence

Turn the encoder knob to select the menu SEQUENCE, then push it to confirm the operation.

If there are no sequences in the user memory, a message stating this will show up on the screen and an acoustic signal will sound. Otherwise the list of the stored sequences will be loaded onto the screen.

You can abort the loading operation by pushing the button EXIT and the screen of the main menu of the PROGRAM LOAD button will show up again. You can read the details of each sequence by pushing the button DETAILS.

To load a sequence, select it with the encoder knob and then push the knob.

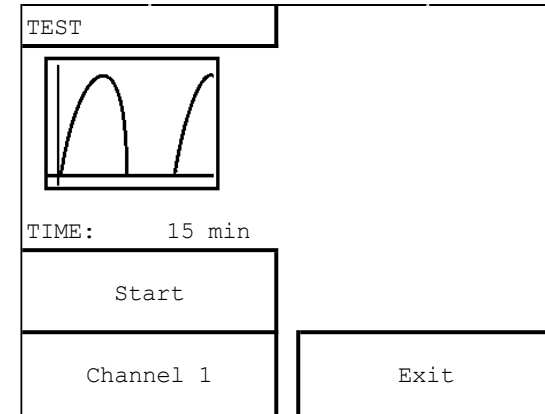

Fig.9

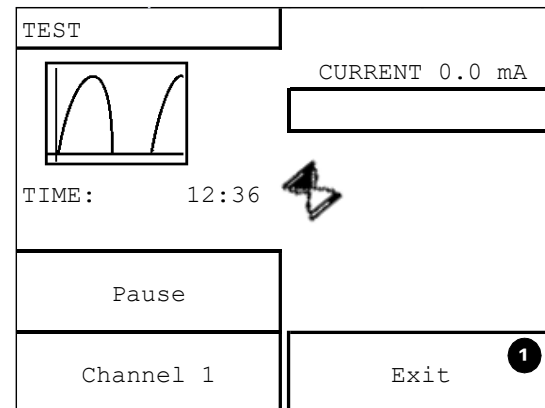

Fig.10

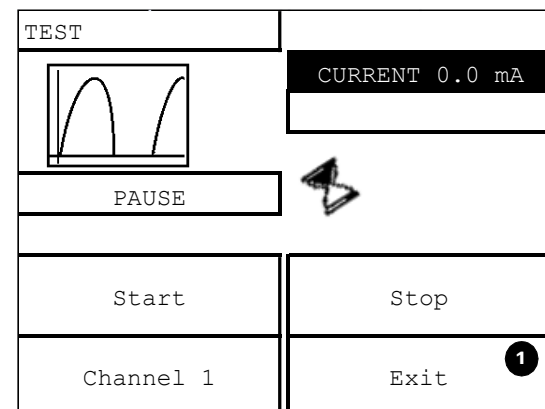

Fig.11

If you want to abort the loading of the sequence push the button EXIT.

To cancel the program sequence selected push the button CANCEL. The list of the sequences stored in the user memory will be updated. Whereas to load the selected sequence push the button LOAD.

After choosing the program sequence, the screen with all the parameters of the treatment chosen will appear. You can modify the treatment emission time, polarity, inversion halfway the period, type of emission, following the procedure described in HOW TO LOAD PROGRAMS FROM THE MAIN MEMORY.

You can choose the output channel, between the channels available (2 in the case of THERAPIC 9200 or 4 in the case of THERAPIC 9400), by pushing the button CHANNEL 1 in succession until the button reading the desired channel will show up.

To start a program push the button START, while to abort the execution of a program, push the button EXIT.

Push the button EXIT some times to go back to screen in pic.2

How to load and I/T curve

Turn the encoder knob to select the menu I/T CURVE, then push it to confirm the operation.

If there are no I/t curves in the user memory, a message stating this will show up on the screen and an acoustic signal will sound. Otherwise the list of the stored I/t curves will be loaded onto the screen.

You can abort the loading operation by pushing the button EXIT and the screen of the main menu of the PROGRAM LOAD button will show up again.

To load an I/t curve, select it with the encoder knob and then push the knob.

You can abort the loading operation by pushing the button EXIT

To cancel the I/t curve selected push the button CANCEL. The list of the I/t curves stored in the user memory will be updated. Whereas to load the selected I/t curve push the button LOAD.

To clean off the I/t curve chart on the screen push the button RESET. While to start to capture data of a new I/t curve and to alternate pulse type (rectangular and triangular) push the button FREE PROCEDURE. You can read further details in the paragraph related to the creation of an I/t curve.

Push the button SAVE to store the I/t curve you just created with the free procedure. While you can push the button RESET to clean off the I/t curve chart on the screen.

If you want to abort the storing of a new I/t curve push the button EXIT.

Push the button EXIT some times to go back to screen in pic.2.

How to load values of rheobase and chronaxie of a selected program

Turn the encoder knob to select the menu RHEOBASE/CHRONAX, then push it to confirm the operation.

If there are no programs in the user memory, a message stating this will show up on the screen and an acoustic signal will sound. Otherwise the list of the stored programs will be loaded onto the screen.

You can abort the loading operation by pushing the button EXIT and the main menu of the PROGRAM LOAD button will show up again. To load the program with the selected values of rheobase and chronaxie, select it and push the encoder knob.

If you want to abort the loading of the selected program push the button EXIT.

To cancel the selected program push the button CANCEL. The list of the programs with the values of rheobase and chronaxie stored in the user memory will be updated.

Instead, to load the selected program push the button LOAD.

By default the encoder point will be placed on the impulse type parameter; choose the pulse type between rectangular and triangular shapes (see pic.12).

Push the button EXIT to abort the loading operation and you will get back to pic.7. Instead, to start calculating the rheobase and chronaxie push the button START (see pic.13).

Push the encoder knob after selecting the menu INTENSITY to modify the current intensity.

Turn the encoder knob clockwise for increasing values and anticlockwise for decreasing values until you choose the desired intensity value.

Push the encoder knob to select the intensity value, then push the button CONFIRM and the rheobase value will be determined (see pic.14).

Then rotate the encoder knob until to position the cursor on the PULSE menu , then press the encoder knob for to enter in the routine of modification of the pulse duration.

Rotate the encoder knob (in clockwise way for increasing values , in counterclockwise way for decreasing values) until to select the desired value to assign at the pulse duration.

Press the encoder knob for to confirm the assignation of the selected value at the pulse duration , then press the CONFIRM button and the chronaxie value will be determined (see pic.15).

You can abort this operations of extraction of the reobase / chronaxie values by pushing the button STOP in the screen of pic.13 or pic.14, then you will go back to the screen in pic.12.

Push the button SAVE in the screen of pic.15 to continue saving the rheobase and chronaxie values of the selected program, then you will go back to pic.7. Otherwise push the button EXIT to abort the saving procedure and you will go back nevertheless to pic.7.

Push the button EXIT some times to go back to screen in pic.2

HOW TO LOAD PROGRAMS FROM THE SMART CARD

The smart card is one of the slave memories of the device.

You can store in it therapeutic programs, sequence of therapeutic programs, i/t curve, values of rheobase and chronaxie.

If the smart card is not inserted or inserted not correctly in the relative slot, a message on this will show up on the screen with an acoustic signal.

If the smart card is inserted correctly in the slot, follow the instructions on how to load programs, program sequences, i/t curve, rheobase and chronaxie values, described in the paragraph HOW TO LOAD PROGRAMS FROM THE USER MEMORY.

CREATE PROGRAMS

This feature allows you to save therapeutic custom programs, that can be stored on smart cards or on user memory, which are the two available memories to save the new programs.

To create a program, press the button CREATE PROGRAMS: a new screen will appear to create a program, create a sequence of programs (no more than 4), create an i/t curve and to calculate the values of rheobase and chronaxie from a new program.

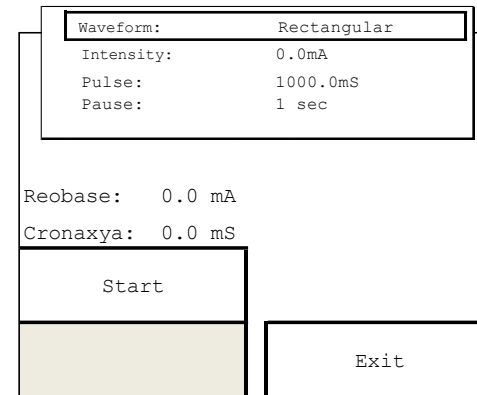

Fig.12

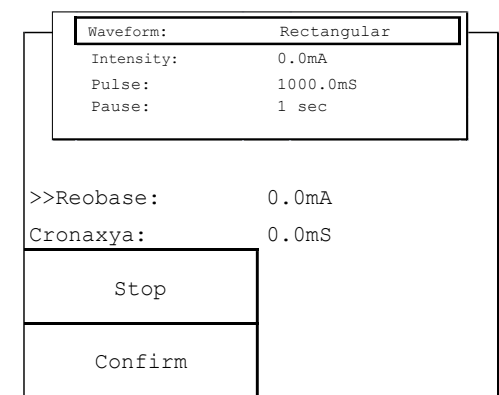

Fig.13

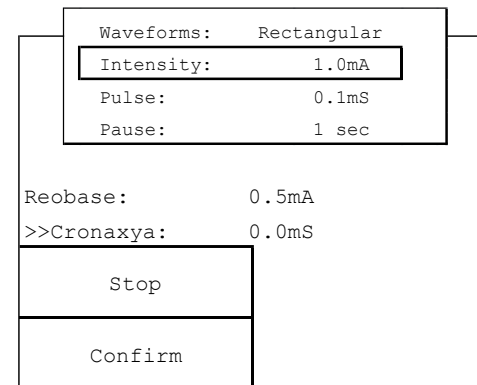

Fig.14

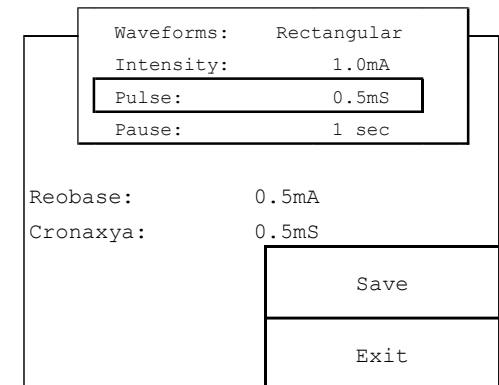

Fig.15

Turn the encoder knob to position the cursor on the desired function, then press the same knob to confirm the execution of the selected operation.

How to create a program

In order to create a new program follow these steps:

1. Press the CREATE PROGRAMS button (fig.2);
2. Turn the encoder knob till the cursor it's positioned on PROGRAM menu;

3. Press the encoder knob to confirm your choice: the screen on fig.16 will appear.

You can customize the program, by changing the selected waveform and / or the values of its characterizing parameters: duration of treatment, polarity, reversing half period and type of emission. To cancel the creation of the program, press the EXIT button: you'll return to the screen shown in Figure 6.

Otherwise, press the SAVE button to save the program on a storage media available (user memory or smart-card): screen appears in Figure 17.

To assign a name to your custom program use the following procedure:

1. press the encoder knob to enable the insertion of the name for the program (see fig.18);
2. Turn the encoder knob to select the desired alphanumeric character (turning the encoder knob, you can select the entire set of alphanumeric characters), see the screen in Figure 19;
3. press the encoder knob to confirm the entry of the alphanumeric character selected (see fig.20);
4. Turn the encoder knob to position the cursor on a new space in order to proceed with entering the next alphanumeric character;

Repeat steps 1) to 4) to fully enter the name you want to assign to the program (see fig.21).

Press the OK button to confirm the assignment of the name you typed in your program. Fig.22 screen appears where you can:

- press the USER PROGRAM button to save the program in the user memory;
- Press PROGRAMS SMART-CARD to save your program in the smart-card;
- press the EXIT button if you want to cancel the creation of the custom program, you return to the screen shown in Figure 6.

Once you select the storage medium, after a few seconds a screen will appear that informs you of the completion of the requested operation (fig. 23) then automatically returns to the screen fig.6.

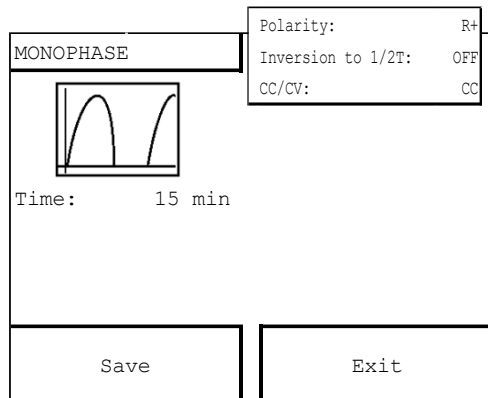

Fig.16

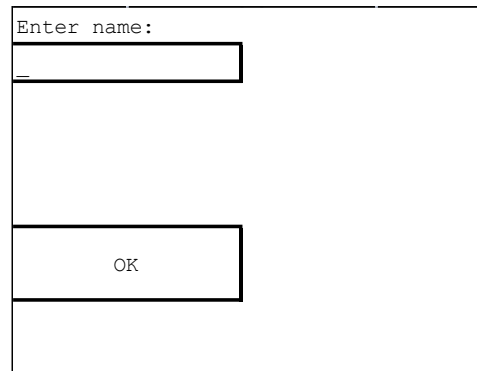

Fig.17

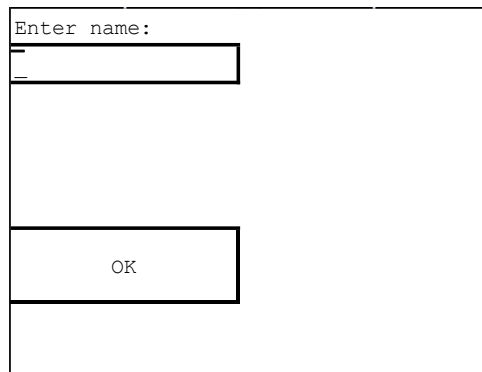

Fig.18

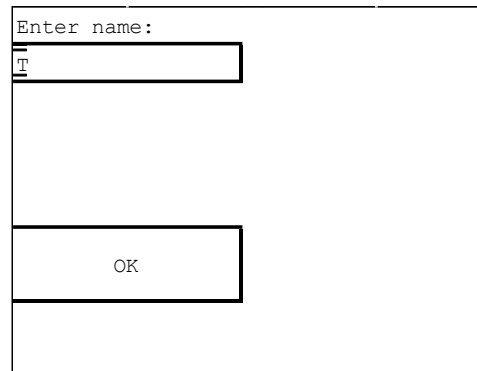

Fig.19

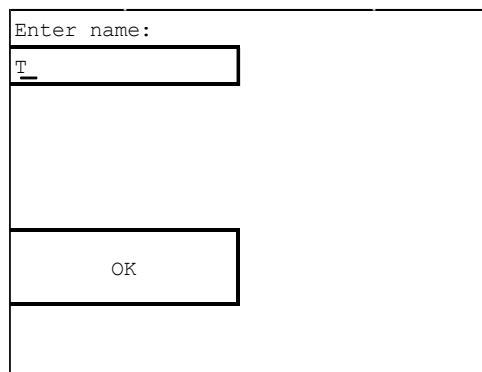

Fig.20

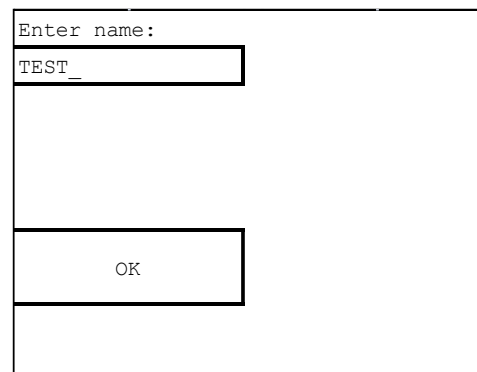

Fig.21

How to create a sequence

In order to create a new sequence follow these steps:

1. press the CREATE PROGRAMS button (fig.2);
2. turn the encoder knob till the cursor is positioned on SEQUENCE menu;
3. press the encoder knob to confirm your choice.

The screen of Figure 24 appears in which you can store a sequence of up to 4 programs.

The cursor is by default set to STEP 1, then press the encoder knob to enter the first program in the sequence.

The screen in Figure 16 appears in which you can customize the program by changing the selected waveform and / or the values of its characterizing parameters: treatment duration, polarity reversal at mid-term and type of emission.

To cancel the creation of the new program, press the EXIT button, it returns to the screen in Figure 24. Otherwise, press the SAVE button.

You will find the stored program in the sequence you are creating (see an example in fig.25).

Rotate again the encoder knob to position the cursor on the menu STEP 2, then press the encoder knob to confirm and follow the above steps to save a new program in the sequence.

You can follow the same procedure for the other two empty positions, for a maximum of 4 programs in a sequence (See an example in fig.26).

To cancel the creation of the sequence, press the EXIT button, it returns to the screen shown in Figure 6. Otherwise, press the SAVE button to save the newly created sequence.

The screen in Figure 17 appears, allowing you to assign a name to the custom sequence in the same way described in the previous paragraph.

Once you select the storage medium, after a few seconds a screen will appear that informs the operator of the completion of the operation (fig. 23) and automatically returns to the screen fig.6.

Enter name:
 TEST

User Program

Smart-Card Progr. Exit

Fig.22

Enter name:
 TEST

Saving completed!

User Program

Smart-Card Progr. Exit

Fig.23

SELECT

STEP 1	[EMPTY]
STEP 2	[EMPTY]
STEP 3	[EMPTY]
STEP 4	[EMPTY]

Save Exit

Fig.24

SELECT

STEP 1	[MONOPHASE]
STEP 2	[EMPTY]
STEP 3	[EMPTY]
STEP 4	[EMPTY]

Save Exit

Fig.25

SELECT

STEP 1	[MONOPHASE]
STEP 2	[DIPHASE]
STEP 3	[SINC,MONOPHASE]
STEP 4	[SINC,DIPHASE]

Save Exit

Fig.26

The idea that underlies the creation of a sequence that is at the end of a delivered program the machine steps to dispense the next program, depending on the channel on which it is loaded; this is repeated until the sequence has completed.

In the creation of a sequence is not possible to save programs in not consecutive positions.

How to create an I/t curve

The I/t CURVE is the graphical representation of the perceptible thresholds of muscle stimulation and is useful for controlling the improvement resulting from a therapy or a surgery.

Rectangular or triangular waveforms are used on the same application points where the electrodes are placed for regular electrotherapy.

The electrotherapy channel enabled for the creation of the curve I / t is always the CHANNEL 1.

Before proceeding with the curve I / t is necessary to format the secondary storage (smart card or user memory) where you want to store it.

To create a I/t curve follow the instructions below:

1. place the electrodes (positive and negative) of ELECTROTHERAPY CHANNEL 1 on the ends of the muscle of interest;
2. press the CREATE PROGRAMS button (see Figure 2);
3. Turn the encoder knob to position the cursor on the menu I/t CURVE;
4. then press the encoder knob to confirm the selection.

Figure 27 shows the screen where you can:

- Press the EXIT button to cancel the creation of the I/t curve and you will return to the screen of Figure 6;
- Press the RESET button to clear the screen from any loaded graphic waveform;
- Press EDIT to select the type of pulse you want to use (rectangular or triangular).

The only currently adjustable parameter is the duration of the pause time, which can be varied by means of a simple rotation of the encoder knob (clockwise for increasing values, counter-clockwise for decreasing values).

The acquisition of the curve requires you to press the START button to allow it to operate: fig.28 screen appears.

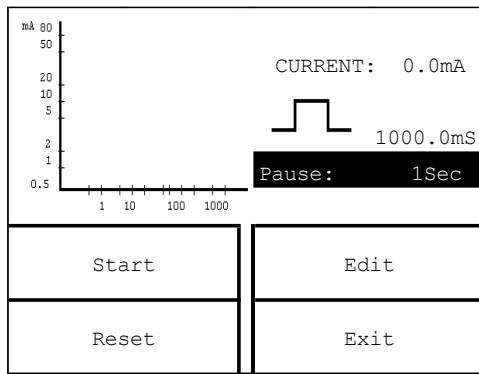

Fig.27

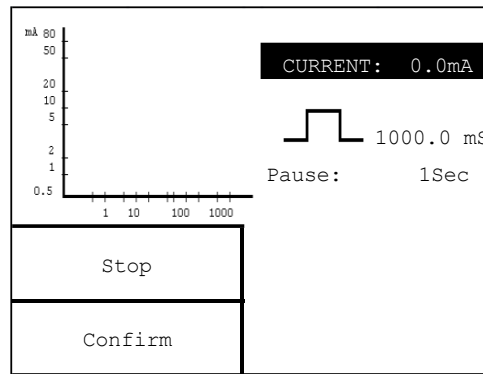

Fig.28

Rotate the encoder knob to define the value of the current intensity (clockwise for increasing values and counter-clockwise for decreasing values).

When the diagnostic operator note a reaction of muscle to the stimulus press the CONFIRM button to confirm the entry of the selected value and the acquisition of the same curve in the graph of I/t curve.

Automatically, with each storage, the intensity of the pulse is reset to zero and prepared the new pulse time; diagnostic operator has the task of detecting the intensity that causes a contraction perceptible.

Press the STOP button to stop the sequence at any time.

If the sequence is stopped with the STOP button, it can be restarted at the same point with the START button.

The curve I / t can be stored always but to have a significant curve I / t it is necessary to acquire all of the 11 steps, then repeat the above procedure for all steps that comprise the creation of the curve I / t.

At the end of the acquisition process, it displays a screen where you can:

- Press the EXIT button to cancel the acquisition of I/t curve; returns to the screen fig.6;
- Press the RESET button to clear the screen from any loaded graphic waveform;

- Press the SAVE button to save the I/t curve just got into one of the secondary storage media.

Pressing the SAVE button Figure 17 screen appears, which allows you to assign a name to the custom sequence, following the instructions in the previous paragraph.

Once you select the storage medium, after a few seconds a screen will appear that informs the operator of the completion of the requested operation (fig. 23) then automatically returns to the screen fig.6.

How to extract rheobase and chronaxie values

Once you have chosen the type of pulse (rectangular or triangular) and the pause time, it is possible to trace the values of rheobase and chronaxie.

The rheobase is the intensity of the stress felt by the patient after delivering a pulse 1 second long.

The chronaxie is the time taken to measure muscle contraction after giving a signal intensity of the double value set arbitrarily by the user.

While the first parameter is detected directly by the software, the second parameter is detected during the delivery of the therapeutic treatment: in fact it can be measured from the time that is allowed to vary the pulse width, capable of producing the muscle contraction.

The electrotherapy channel enabled for extract the of the values of rheobase and chronaxie is always the CHANNEL 1.

In order to extract the values of rheobase and chronaxie follow these instructions:

1. place the electrodes (positive and negative) of ELECTROTHERAPY CHANNEL 1 on the ends of the muscle of interest;
2. press the CREATE PROGRAMS button (see Figure 2);
3. turn the encoder knob to position the cursor on the menu RHEOBASE/CHRONAXIE;
4. press the encoder knob to confirm the selection: Figure 12 screen is displayed.

The cursor is positioned by default on the type of impulse; then choose the type of impulse between the rectangular and the triangular waveform.

Press the START button to begin the rheobase and chronaxie calculation routine (see fig.13).

Rotate and the press the encoder knob on the INTENSITY menu to enter the routine for changing the current value.

Rotate the encoder knob clockwise for increasing values or counter-clockwise for decreasing values, to select the desired current value.

Press the encoder knob to confirm the selected current value, then press the CONFIRM button to show the extracted rheobase value: appears the screen of pic.14.

Then rotate the encoder knob until to position the cursor on the PULSE menu , then press the encoder knob for to enter in the routine of modification of the pulse duration.

Rotate the encoder knob (in clockwise way for increasing values , in counterclockwise way for decreasing values) until to select the desired value to assign at the pulse duration.

Press the encoder knob for to confirm the assignation of the selected value at the pulse duration , then press the CONFIRM button and the chronaxie value will be determined: appears the screen of pic.15.

You can abort this operations of extraction of the reobase / chronaxie values by pushing the button STOP in the screen of pic.13 or pic.14, then you will go back to the screen in pic.12.

Press the SAVE button in the screen of pic.15 to continue and save rheobase and chronaxie values in one of the secondary storage media, following the instructions described in "CREATE PROGRAMS" at the "How to create a program" section.

COMBINED USE

ULTRASOUNDS

You can use the "LINK" cable (see ACCESSORIES section) to connect a THERAPIC unit to an ULTRASONIC unit; this union allows to realize an hardware connection between the devices, and it allows to emit combined treatments of electro-therapy and ultrasound-therapy .

It is possible to combine the two machines simply by connecting the LINK cable to the two "LINK" connectors on the electrotherapeutic device and on the ultrasound device respectively.

For this scope, you must to apply on the patient the positive electrode of the channel 1 of electrotherapy and the ultrasound probe, because the ultrasound probe due to

LINK cable represents the negative electrode of the channel 1 of the electrotherapy. This connection allows to substitute to an hardware level the negative electrode of the channel 1 of the electrotherapy with the ultrasound probe.

This means that :

- Pushing the START button on ULTRASONIC unit but not on THERAPIC unit , the ultrasound-therapy treatment will be emitted normally.
- Pushing the START button on THERAPIC unit and on ULTRASONIC unit too , the ultrasound probe becomes the emission terminal both for the ultrasound-therapy treatment or the electro-therapy treatment (acting as alias of the negative electrode of channel 1)

The remaining channels (CHANNEL 2 for THERAPIC 9200, and CHANNEL 3 and 4 for THERAPIC 9400) are still available for the treatment of electrotherapy.

MAINTENANCE

The THERAPIC-series device for the electrotherapy do not require any particular maintenance operations , but only a periodic maintenance and cleanliness of the probes, in order to ensure the better operating conditions, guarantee the effectiveness of the treatment and the safety of the patient. A special intervention is not required in the event of failure of the medical device, but just a normal maintenance/repair .

When cleaning the outer part of the equipment, make sure to use a soft, clean cloth dampened with luke-warm water or very mild non inflammable detergents. The front panel can be cleaned in the same way .

The electrodes in conductive rubber must be regularly cleaned with water and denatured alcohol.

Replace the cables and electrodes with care at the end of each treatment session. The electrodes in conductive rubber must be periodically replaced as they lose their conductivity with use

Contact authorised dealers of EME srl for information regarding original spare parts or components

Do not spray or pour liquid onto the external parts of the equipment and onto the probes. Do not immerse the unit in water. After cleaning the external part of the equipment, make sure to dry it perfectly before turning on the unit.

The unit must under no circumstances be opened or dismantled in order to clean or check inner parts of equipment does not require cleaning of inner parts and in all cases, only specialised technicians or EME srl authorised personnel should carry out such operations.

The expected work life of device is 10 years.

TECHNICAL PROBLEMS

The equipment for electrotherapy has been designed and manufactured using highly advanced technology and first class components for reliable and efficient performance.

However, should you meet with any operational problems, we recommended that you consult the following guide before contacting any of our authorised service centres.

If any of the following situations occur, disconnect the machine and contact EME srl authorised service centres:

- the cable set or rear supply panel show signs of wear and tear or are damaged;
- the liquid has entered the equipment
- the equipment has been exposed to rain.

ELECTROMAGNETIC INTERFERENCES

The equipment for electrotherapy, THERAPIC-series, has been designed and manufactured according to the ELECTROMAGNETIC COMPATIBILITY DIRECTIVE 2014/30/UE with the aim of providing adequate protection from harmful interference when installed in homes and health establishments.

All required measurements and tests have been carried out in EME's internal Testing, Measurement and Inspection laboratory (LPMC), in addition to other external specialised institutes. The customer, upon prior request, may view the reports relative to EMC measures within the company.

The equipment does not generate significant radio frequency energy and is adequately immune to radiated electromagnetic fields. Therefore it does not detrimentally interfere with radio-electric communications, electro-medical equipment for monitoring, diagnosis, therapy and surgery, office electronic devices such as computers, printers, photocopiers, fax machines, etc. or any electric or electronic equipment used in these environments, as long as said equipment complies with the ELECTROMAGNETIC COMPATIBILITY directive .

In any case, in order to avoid any interference problems, we recommend that you operate the therapy equipment far enough away from critical equipment for monitoring vital patient functions, and that you be careful when applying therapy to patients with pacemakers.

TROUBLESHOOTING CHART

PROBLEM	POSSIBLE CAUSE	SOLUTION
Front panel LCD display doesn't come on: the unit doesn't work.	Mains plug not plugged in properly	Check that the mains socket is working
	Mains cable not properly connected to the unit	Plug in properly and connect cable to the unit
	Mains cable worn or blocked.	Replace the mains cable.
	Switch off.	Switch on the mains switch.
	Fuse or fuses defective or blown.	Replace the missing, defective or blown fuses.
	Electronic control circuit malfunction.	Contact the EME srl assistance centre
Front panel LCD display doesn't come on	Defective components in the electronic control board.	Contact the EME srl assistance centre
Some commands on the front control panel are not working properly.	Defective keys or buttons.	Contact the EME srl assistance centre
	Electronic control system malfunction.	
The display signals that the unit is unable to supply the required output current .	Defective connections in the patient application output circuit.	Check that the output connection is made properly.
	Output cable blocked or not connected properly.	
	Output cable worn and/or bad connection.	
	Connectors badly inserted, defective or not connected to the equipment and/or the electrodes.	Connect the output cables correctly. Replace the cables and/or the defective connectors that show evident signs of wear.
	Electrodes in conductive rubber worn, need to be replaced	Ensure that the electrodes adhere properly to the patient, replace defective and/or worn electrodes.

PROBLEM	POSSIBLE CAUSE	SOLUTION
	Contact with the patient insufficient, faulty, and/or uncertain.	Contact the EME srl assistance centre
	Current generator electronic circuit fault	
The unit works properly but there is a notable reduction in the effectiveness of the treatment	The output circuit from the patient is not connected properly.	Carry out maintenance operations as described. Install and position the unit as described
	Uncertain or defective conductive rubber electrode contacts (including the electrode-holder sponge pockets) with the surface to be treated	Check the condition of the cables, the connectors and the output circuit electrodes Ensure the electrodes adhere perfectly to the treatment surface. Moisten the electrode-holder sponge pockets.
	Possible current generator circuit fault in the equipment.	Contact the EME srl assistance centre

TECHNICAL FEATURES

Main voltage:		230 Vac, 50-60Hz, ±10%
Max. Power absorption:	THERAPIC 9400	75 VA
	THERAPIC 9200	
Double delay type (T) mains fuse protection:	THERAPIC 9400	315 mA - T - 5 x 20 mm for alimentation 230Vac
	THERAPIC 9200	
Backlit LCD Display, to visualise and control operating parameters		Colour graphic 320 x 240 pixel touch screen +encoder
Programmable treatment time		up to 60 minutes
<u>Class of isolation/parts applied according to the rule EN 60601-1</u>		<u>I / BF</u>
<u>Classification in compliance with the directive 93/42/CEE</u>		<u>II B</u>
<u>Degree of protection against the input of liquids according to the UNI EN 60601-1 standard</u>		<u>IPX0</u>
Emission frequency	THERAPIC 9200	All low and medium frequency currents , 25 Waveforms total number
	THERAPIC 9400	
Functioning:	THERAPIC 9200	Voltage Costant Current Costant
	THERAPIC 9400	
Peak current (Load resistance 1KOhm)	Pulse current	100 mA
	Diadynamic current	70 mA
	Continuous current	50 mA
Peak voltage (Load resistance 1KOhm)	Pulse current	100 V
	Diadynamic current	70 V
	Continuos current	50V
Channel output:	THERAPIC 9400	4 independents
	THERAPIC 9200	2 independents
Number of protocols that can be saved in the user memory		200
Sequences that can be saved in the user memory		10
<u>Curve I/t that can be saved in the user memory</u>		100
<u>Value of reobase/cronaxya that can be saved in the user memory</u>		100
Number of protocols that can be saved in the smart-card		50

Sequences that can be saved in the smart-card		10
<u>Curve I/t that can be saved in the smart-card</u>		20
<u>Value of reobase/cronaxya that can be saved in the smart-card</u>		10
Table container in plastic, external size (width x height x depth)		39 x H14 x 30 cm
Unit body weight	THERAPIC 9400	6,2 Kg
	THERAPIC 9200	5,6 Kg
<u>Conditions for use</u>	<u>Room temperature</u>	<u>(+10 : +40) °C</u>
	<u>Relative humidity</u>	<u>(10 : 80) % without condensation</u>
<u>Conditions for stocking / transport</u>	<u>Room temperature</u>	<u>(-40 : +70) °C</u>
	<u>Relative humidity</u>	<u>(10 : 100) % without condensation</u>
	<u>Atmospheric pressure</u>	<u>(500 : 1060) hPa</u>

APPENDICES

Appendix A - ENVIRONMENTAL CONSIDERATIONS

THERAPIC-series equipment for electrotherapy has been designed and manufactured to have minimal negative environmental impact, in line with its operational and safety requirements.

Rigorous standards were followed in order to minimise the amount of waste, use of toxic materials, noise, non-required radiation and energy consumption.

In accordance with careful research, the unit has been designed to optimise power consumption in keeping with energy saving principles.



This symbol means that the product should not be disposed of as domestic waste.

The user must dispose of scrap equipment by taking it to a recognised electrical and electronic recycling centre.

Appendix B – LABELS













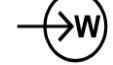

Simbol Signification	Simbol Signification
 This product complies with regulations issued under the certification from a Notified Body	 Applied part BF
 Attention	 The product must be dispose of as “electronic waste”, not as “domestic waste”
 input characteristics	 Input voltage to the device (mains)
 Fuses: 2xT315mAL250V DIM: 5x2mm	 Input power of the device (absorbed power)
 Input frequency of the device	 Device model
 Serial number	 Output characteristics of the device
 Output voltage of the device	 Output current of the device
 Output frequency of the device	 Consult the user manual
 Temperature range	 Atmospheric pressure range
 Humidity range	

Table 1







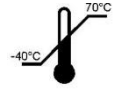
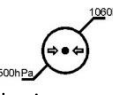
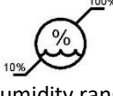





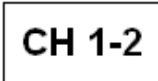
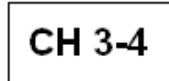





Label Signification	Label Signification
 Label indicating devices sensitive to electrostatic charges, placed near the connector for serial connection	 Label placed near the LINK connector , used for a connection towards an ULTRASONIC unit , situated on the rear panel of the device
 Label placed near the connector for output channel 1 and 2.	 Label placed near the connector for output channel 3 and 4 (only for THERAPIC 9400)
 Label indicating the mandatory reading of instructions, located on the front panel of the device or near the output connectors	









Table 2



Appendix C – LIST OF THERAPEUTIC SUGGESTIONS

Reference SW	Electrotherapy treatment	Waveform associated	Time length (min)	Pulse length	Action time (sec)	Pause time (sec)	Modulation (Hz)		Frequency (Hz)	Electrodes positioning	N° of sessions
							Minima	Maxma			
PATHOLOGY01	Local dermal anesthesia (Fentanyl)	Galvanic	10 min * the treatment time depends on the desired dose							Variable positioning of the electrodes cannot be defined a priori.	1
PATHOLOGY02	Local dermal anesthesia (Lydoc.)	Galvanic	10 min * the treatment time depends on the desired dose							Variable positioning of the electrodes cannot be defined a priori.	1
PATHOLOGY 03	Arthritis (wrists and hands)	Modulated Pharadic	15	1 ms	1 s	0 s			70		15
PATHOLOGY 04	Knee Rheumatoid Arthritis (Dexamethasone)	Galvanic	20 the treatment time depends on the desired dose								1
PATHOLOGY 05	Arthritis in the extremities	TENS Random S/A/R	30	50 µs	1	0			10	Variable positioning of the electrodes cannot be defined a priori.	3
PATHOLOGY 06	Cervical arthritis	TENS Random S/A/R	30	50 µs	1	0			10		3
PATHOLOGY 07	Arthrosis of the acromioclavicular joint	TENS Random S/A/R	20	150 µs	1	0			100		12
PATHOLOGY 08	Muscle atrophy (only on Paraplegics)	Modulated Pharadic	10	300 µs	5	5			40	Variable positioning of the electrodes cannot be defined a priori..	20
PATHOLOGY 09	Calcifications of the hand	Galvanic	20								12
PATHOLOGY 10	Pain in the hip	Tens Random S/A/R	30	200 µs	1	0			100		10

Reference SW	Electrotherapy treatment	Waveform associated	Time length (min)	Pulse length	Action time (sec)	Pause time (sec)	Modulation (Hz)		Frequency (Hz)	Electrodes positioning	N°of sessions
							Minima	Maxma			
PATHOLOGY 11	Myofascial cervical pain 1	Bifasica asimmetrica	20	250 μ s		0	100	100			20
PATHOLOGY 12	Myofascial cervical pain 2	Interpherenial	20			0	100	100	4000		20
PATHOLOGY 13	Neck pain	Tens S/A/R	30	150 μ s		0	80	80			15
PATHOLOGY 14	Chronic pain	Tens S/A/R	20	200 μ s		0	2	2		Variable positioning of the electrodes cannot be defined a priori.	15
PATHOLOGY 15	Pain Phantom limb	Tens Random	30	50 μ s	1	0			10	Variable positioning of the electrodes cannot be defined a priori.	3
PATHOLOGY 16	Causal Pain	Tens Random	30	50 μ s	1	0			10	Variable positioning of the electrodes cannot be defined a priori.	3
PATHOLOGY 17	Atypical facial pain	Tens Random	30	50 μ s					10	Variable positioning of the electrodes cannot be defined a priori.	3
PATHOLOGY 18	Knee pain	Kotz	20		1	10	5000	40			20
PATHOLOGY 19	Myofascial pain (jaw)	Tens S/A/R	15	0.5 ms		0	50	50			10
PATHOLOGY 20	Wrist and hand pain	Synchoped Diphase	30		1	0			100	Variable positioning of the electrodes cannot be defined a priori.	20
PATHOLOGY 21	Post-surgical pain 1	Tens Random	30	50 μ s	1	0			10	Variable positioning of the electrodes cannot be defined a priori.	3
PATHOLOGY 22	Post-surgical pain 2	Modulated Pharadic	30	300 μ s	1	0			100	Variable positioning of the electrodes cannot be defined a priori.	
PATHOLOGY 23	Postoperative pain (lower abdomen)	Modulated Pharadic	30	200 μ s	1	0			80	Variable positioning of the electrodes cannot be defined a priori.	20



Reference SW	Electrotherapy treatment	Waveform associated	Time length (min)	Pulse length	Action time (sec)	Pause time (sec)	Modulation (Hz)		Frequency (Hz)	Electrodes positioning	N°of sessions
							Minima	Maxma			
PATHOLOGY 24	Post-surgical pain (inguinal hernia)	Biphasic S/A	30	100 μ s		0	100	100		Variable positioning of the electrodes cannot be defined a priori.	5
PATHOLOGY 25	Post-traumatic pain in the legs	Tens Random	30	50 μ s	1	0			10	Variable positioning of the electrodes cannot be defined a priori.	3
PATHOLOGY 26	Shoulder pain	Triangular	15	700 μ s		0	150	150			3
PATHOLOGY 27	Hemiplegic shoulder pain	Tens S/A/R	60	100 μ s		0	100	100			20
PATHOLOGY 28	Stabilized hip fracture (post surgery pain)	Tens S/A/R	30	200 μ s		0	100	100		Variable positioning of the electrodes cannot be defined a priori..	5
PATHOLOGY 29	Epicondylitis	Interpherenial	20			0			8000		6
PATHOLOGY 30	Epicondylitis (naproxen)	Interrupt Galvanic									1
PATHOLOGY 31	Fracture secondary to osteoporosis	Tens Random	30	50 μ s	1	0			10	Variable positioning of the electrodes cannot be defined a priori.	3
PATHOLOGY 32	Peripheral nerve entrapment	Tens Random	30	50 μ s	1	0			10	Variable positioning of the electrodes cannot be defined a priori.	3
PATHOLOGY 33	Palm-plantar hyperhidrosis	Galvanic	20							Variable positioning of the electrodes cannot be defined a priori.	12
PATHOLOGY 34	Hypotrophy of the vastus medialis	Biphasic S/A	20	300 μ s		3	40	40		Variable positioning of the electrodes cannot be defined a priori.	6
PATHOLOGY 35	Lower limb muscle ischemia from PAD (Muscle tone)	Neodynamic	60			0	1	250		Variable positioning of the electrodes cannot be defined a priori.	6
PATHOLOGY 36	Lower limb muscle ischemia from PAD (Muscle perfusion)	TENS S	45	200 μ s		0	10	10		Variable positioning of the electrodes cannot be defined a priori.	15

Reference SW	Electrotherapy treatment	Waveform associated	Time length (min)	Pulse length	Action time (sec)	Pause time (sec)	Modulation (Hz)		Frequency (Hz)	Electrodes positioning	N°of sessions
							Minima	Maxma			
PATHOLOGY 37	Peripheral nerve injury (pain)	Modulated Pharadic	20	200 μ s	1	0			100	Variable positioning of the electrodes cannot be defined a priori..	10
PATHOLOGY 38	Acute low back pain	Interpherenial	30			0	140	140	4000		12
PATHOLOGY 39	Low back pain	Tens Random	30	50 μ s	1	0			10		15
PATHOLOGY 40	Post-surgical neuralgia	Tens Random	30	50 μ s	1	0			10	Variable positioning of the electrodes cannot be defined a priori.	3
PATHOLOGY 41	Post-herpetic neuralgia	Tens Random	30	50 μ s	1	0			10	Variable positioning of the electrodes cannot be defined a priori.	3
PATHOLOGY 42	Knee osteoarthritis 1-2	Interpherenial	15			0	100	100	4000		10
PATHOLOGY 43	Knee osteoarthritis 2-2	Interpherenial	5			0	80	80	4000		10
PATHOLOGY 44	Knee osteoarthritis 3	Modulated Pharadic	15	300 μ s	10	50			70		20
PATHOLOGY 45	Quadriceps strength recovery after ACL reconstruction (Anterior Cruciate Ligament)	Modulated Pharadic	20	300 μ s	6	10			30	Variable positioning of the electrodes cannot be defined a priori.	10
PATHOLOGY 46	Sciatalgia 1	Tens Random	30	0.1 s	1	0			4		9
PATHOLOGY 47	Sciatalgia 2	Tens S/A/R	20	250 μ s		0	4	4			3
PATHOLOGY 48	Shoulder impingement syndrome 1	Interpherenial	19			0	50	120	2500		12

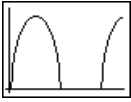
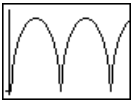
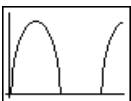
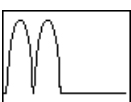
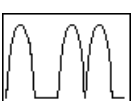

Reference SW	Electrotherapy treatment	Waveform associated	Time length (min)	Pulse length	Action time (sec)	Pause time (sec)	Modulation (Hz)		Frequency (Hz)	Electrodes positioning	N°of sessions
							Minima	Maxma			
PATHOLOGY 49	Shoulder impingement syndrome 2	Tens S/A/R	20	100 μ s		0	100	100			12
PATHOLOGY 50	Painful myofascial syndrome [1]	Tens Random	30	50 μ s	1	0			10	Variable positioning of the electrodes cannot be defined a priori.	3
PATHOLOGY 51	Painful myofascial syndrome [2]	Interrupt Galvanic	20		6	3			8000	Variable positioning of the electrodes cannot be defined a priori.	9
PATHOLOGY 52	Patello-femoral pain syndrome	Biphasic S/A	30	500 μ s		0	50	50		Variable positioning of the electrodes cannot be defined a priori.	12
PATHOLOGY 53	Ankylosing spondylitis	Tens S/A/R	20	50 μ s		0	50	50		Variable positioning of the electrodes cannot be defined a priori.	15
PATHOLOGY 54	Perial stretch of the supraspinatus tendon	TENS Random S/A/R	20	150 μ s	1	0			100	Variable positioning of the electrodes cannot be defined a priori.	20
PATHOLOGY 55	Tendinopathy of the supraspinatus	Tens S/A/R	20	150 μ s	1	0			100		20
PATHOLOGY 56	Insertional Achilles Tendonitis (Acetic Acid)	Galvanic	20							Variable positioning of the electrodes cannot be defined a priori.	1
PATHOLOGY 57	Painful tic	Tens S/A/R	30	50 μ s	1	0			10	Variable positioning of the electrodes cannot be defined a priori.	3
PATHOLOGY 58	Ulcers (non-diabetic)	Biphasic S/A	30	250 μ s		0	40	40		Variable positioning of the electrodes cannot be defined a priori.	20
PATHOLOGY 59	Vitiligo	Galvanic	10							Variable positioning of the electrodes cannot be defined a priori.	10 o più
TREATMENT 60	Passive muscle warming *	Kotz	12		1	0	100	100	2500	Variable positioning of the electrodes cannot be defined a priori.	12-15
TREATMENT 61	Passive muscle toning *	Kotz	20		1	0	50	50	2500	Variable positioning of the electrodes cannot be defined a priori.	15
TREATMENT 62	Muscle anti-fatigue treatment [1] *	Kotz	15		10	50	50	50	2500	Variable positioning of the electrodes cannot be defined a priori.	3-12
TREATMENT 63	Muscle anti-fatigue treatment [2]*	Monophase	15						50	Variable positioning of the electrodes cannot be defined a priori.	12

*Treatment not covered by medical CE

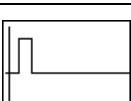
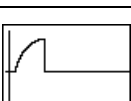
Appendix D – WAVEFORMS

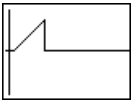
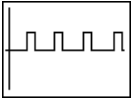
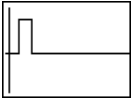
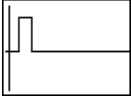
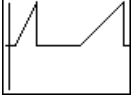
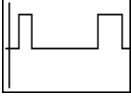
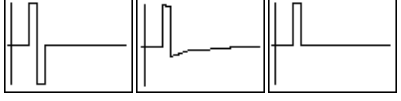
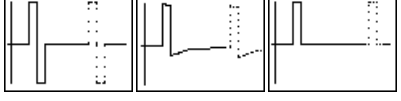
N°	Name of the current waveform		Rise time [sec]	Decay time [sec]	Action time [sec]	Pause time [sec]	Pulse duration	Frequency [Hz]
			Default (Range)	Default (Range)	Default (Range)	Default (Range)	Default (Range)	Default (Range)
			Min time [sec]	Max time [sec]	Monophase duration [sec]	Diphase duration [sec]	Frequency A [Hz]	Frequency B [Hz]
			Default (Range)	Default (Range)	Default (Range)	Default (Range)	Default (Range)	Default (Range)
1	MONOPHASE		/	/	/	/	20ms	50
			/	/	/	/	/	/
2	DIPHASE		/	/	/	/	10ms	100
			/	/	/	/	/	/
3	SYNCHOPED MONOPHASE		1 (0 ÷ 30)	1 (0 ÷ 30)	6 (1 ÷ 120)	5 (0 ÷ 120)	20ms	50
			/	/	/	/	/	/
4	SYNCHOPED DIPHASE		1 (0 ÷ 30)	1 (0 ÷ 30)	6 (1 ÷ 120)	5 (0 ÷ 120)	10ms	100
			/	/	/	/	/	/
5	SHORT PERIOD		/	/	/	2 (0 ÷ 120)	20ms MONOPHASE 10ms DIPHASE	50 MONOPHASE 100 DIPHASE
			/	/	1 (1 ÷ 60)	1 (1 ÷ 60)	/	/
6	LONG PERIOD		/	/	/	6 (0 ÷ 30)	20ms MONOPHASE 10ms DIPHASE	50 MONOPHASE 100 DIPHASE
			/	/	6 (1 ÷ 60)	6 (1 ÷ 60)	/	/
7	RECTANGULAR		1 (0 ÷ 30)	1 (0 ÷ 30)	/	5 (0 ÷ 120)	500 us (100us ÷ 9.0ms)	/
			1 (0 ÷ 120)	3 (1 ÷ 120)	/	/	50 (1 ÷ freq.B) *2	100 (freq.A ÷ 250) *2
8	ESPONENTIAL		1 (0 ÷ 30)	1 (0 ÷ 30)	/	5 (0 ÷ 120)	500 us (100us ÷ 9.0ms)	/
			1 (0 ÷ 120)	3 (1 ÷ 120)	/	/	50 (1 ÷ freq.B) *2	100 (freq.A ÷ 250) *2

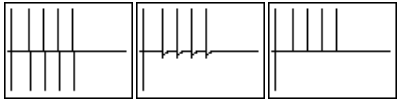
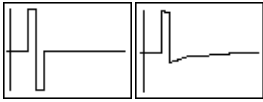
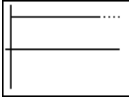
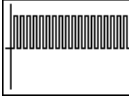
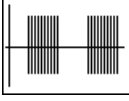
N°	Name of the current waveform		Rise time [sec]	Decay time [sec]	Action time [sec]	Pause time [sec]	Pulse duration	Frequency [Hz]
			Default (Range)	Default (Range)	Default (Range)	Default (Range)	Default (Range)	Default (Range)
			Min time [sec]	Max time [sec]	Monophase duration [sec]	Diphase duration [sec]	Frequency A [Hz]	Frequency B [Hz]
			Default (Range)	Default (Range)	Default (Range)	Default (Range)	Default (Range)	Default (Range)
9	TRIANGULAR		1 (0 ÷ 30)	1 (0 ÷ 30)	/	5 (0 ÷ 120)	500 us (100us ÷ 9.0ms)	/
			1 (0 ÷ 120)	3 (1 ÷ 120)	/	/	50 (1 ÷ freq.B) *2	100 (freq.A ÷ 250) *2
10	TRAEBERT		/	/	/	Pausa impulso:5.0 ms (100 us - 2 s)	2.0ms (100us ÷ 2s)	140
			/	/	/	/	/	/
11	RECTANGULAR PHARADIC		1 (0 ÷ 30)	1 (0 ÷ 30)	/	5 (0 ÷ 120)	500 us (100us ÷ 9.0ms)	/
			1 (0 ÷ 120)	3 (1 ÷ 120)	/	/	50 (1 ÷ freq.B) *2	100 (freq.A ÷ 250) *2
12	MODULATED PHARADIC		1 (0 ÷ 30)	1 (0 ÷ 30)	6 (1 ÷ 120)	5 (0 ÷ 120)	1.0ms (100us ÷ 9.0ms)	100 (1 ÷ 250)
			/	/	/	/	/	/
13	TRIANGULAR NEODYNAMIC		1 (0 ÷ 30)	1 (0 ÷ 30)	/	0 (0 ÷ 120)	/	/
			0 (0 ÷ 120)	1 (1 ÷ 120)	/	/	200 (1 ÷ freq.B) *2	200 (freq.A ÷ 250) *2
14	NEODYNAMIC		1 (0 ÷ 30)	1 (0 ÷ 30)	/	0 (0 ÷ 120)	/	/
			3 (0 ÷ 120)	3 (1 ÷ 120)	/	/	200 (1 ÷ freq.B) *2	200 (freq.A ÷ 250) *2
15	TENS S/A/R		1 (1 ÷ 30)	1 (1 ÷ 30)	/	3 (0 ÷ 120)	100us (50us ÷ 1ms)	/
			0 (0 ÷ 120)	1 (1 ÷ 120)	/	/	100 (1 ÷ freq.B) *2	100 (freq.A ÷ 250) *2
16	TENS RANDOM S/A/R		/	/	1 (1 ÷ 120)	1 (0 ÷ 120)	50us (50us ÷ 1s)	100 (1 ÷ 200)
			/	/	/	/	/	/

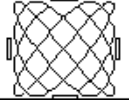
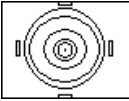
N°	Name of the current waveform		Rise time [sec]	Decay time [sec]	Action time [sec]	Pause time [sec]	Pulse duration	Frequency [Hz]
			Default (Range)	Default (Range)	Default (Range)	Default (Range)	Default (Range)	Default (Range)
			Min time [sec]	Max time [sec]	Monophase duration [sec]	Diphase duration [sec]	Frequency A [Hz]	Frequency B [Hz]
			Default (Range)	Default (Range)	Default (Range)	Default (Range)	Default (Range)	Default (Range)
17	TENS BURST S/A/R 		/	/	1 (1 ÷ 120)	1 (0 ÷ 120)	50us (50us ÷ 1s)	/
			/	/	/	/	100 (1 ÷ 200) *3	2 (1 ÷ 10) *3
18	BIPHASIC S/A 		1 (1 ÷ 30)	1 (1 ÷ 30)	/	3 (0 ÷ 120)	250us (50us ÷ 2ms)	/
			0 (0 ÷ 120)	1 (1 ÷ 120)	/	/	100 (1 ÷ freq.B) *2	100 (freq.A ÷ 250) *2
19	GALVANIC (IONOPHORESIS) 		/	/	1 (1 ÷ 120)	0 (0 ÷ 120)	/	/
			/	/	/	/	/	/
20	INTERRUPTED GALVANIC (IONTOPHORESIS) 		/	/	1 (1 ÷ 120)	0 (0 ÷ 120)	/	8000 (2000 ÷ 8000)
			/	/	/	/	/	/
21	KOTZ 		/	/	1 (1 ÷ 120)	0 (0 ÷ 120)	/	/
			/	/	/	/	2500 (1000 ÷ 5000) *4	50 (1 ÷ 250) *4
22	INTERPHERENTIAL 		1 (0 ÷ 30)	1 (0 ÷ 30)	/	2 (0 ÷ 30)	/	2500 (2500 o 4000) *5
			0 (0 ÷ 120)	1 (1 ÷ 120)	/	/	1 (0 ÷ freq.B) *2	2 (freq.A ÷ 250) *2
23	INTERPHERENTIAL CLASSIC * 		1 (0 ÷ 30)	1 (0 ÷ 30)	/	2 (0 ÷ 120)	/	2500 (2500 o 4000) *5
			0 (0 ÷ 120)	1 (1 ÷ 120)	/	/	50 (0 ÷ freq.B) *2	120 (freq.A ÷ 250) *2
24	INTERPHERENTIAL ISOPLANAR 		1 (0 ÷ 30)	1 (0 ÷ 30)	/	2 (0 ÷ 120)	/	2500 (2500 o 4000) *5
			0 (0 ÷ 120)	1 (1 ÷ 120)	/	/	50 (0 ÷ freq.B) *2	120 (freq.A ÷ 250) *2

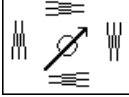
N°	Name of the current waveform		Rise time [sec]	Decay time [sec]	Action time [sec]	Pause time [sec]	Pulse duration	Frequency [Hz]
			Default (Range)	Default (Range)	Default (Range)	Default (Range)	Default (Range)	Default (Range)
			Min time [sec]	Max time [sec]	Monophase duration [sec]	Diphase duration [sec]	Frequency A [Hz]	Frequency B [Hz]
			Default (Range)	Default (Range)	Default (Range)	Default (Range)	Default (Range)	Default (Range)
25	INTERPHERENTIAL VECTORIAL		1 (0 ÷ 30)	1 (0 ÷ 30)	/	2 (0 ÷ 120)	/	2500 (2500 o 4000) *5
			0 (0 ÷ 120)	1 (1 ÷ 120)	/	/	50 (0 ÷ freq.B) *2	120 (freq.A ÷ 250) *2

Note: S -> simmetric, A -> asimmetric, R -> rectangular.

*2 the general range of variation of frequency is (0 Hz ÷ 250 Hz).

*3 in the waveform TENS BURST S/A/R the Frequency A and the Frequency B represent, respectively, the frequency TENS and the frequency BURST with their range of variation.

*4 in the waveform KOTZ the Frequency A and the Frequency B represent, respectively, the CARRIER frequency and the MODULATION frequency with their range of variation.

*5 in the waveforms INTERPHERENTIAL, INTERPHERENTIAL CLASSIC, INTERPHERENTIAL ISOPLANAR, INTERPHERENTIAL VECTORIAL the Frequency represents the CARRIER Frequency.

Appendix E – ELECTRO-MAGNETIC COMPATIBILITY TABLES

Guidance and manufacturer's declaration – electromagnetic emissions FOR ALL ME EQUIPMENT		
The ME EQUIPMENT is intended for use in the electromagnetic environment specified below. The customer or the user of the ME EQUIPMENT should assure that it is used in such an environment.		
Emissions test	Compliance	Electromagnetic environment – guidance
RF Emissions CISPR 11	Group 1	The ME EQUIPMENT uses RF energy only for its internal function. Therefore, its RF emissions are very low and are not likely to cause any interference in nearby electronic equipment.
RF Emissions CISPR 11	Class B	The ME EQUIPMENT is suitable for use in all establishments including domestic establishments and those directly connected to the public low voltage power supply network that supplies buildings used for domestic purposes.
Harmonic emissions IEC 61000-3-2	Class B	
Voltage fluctuations/ flicker emissions IEC 61000-3-3	Complies	

13.4.1 Guidance and manufacturer's declaration – electromagnetic immunity			
The ME EQUIPMENT is intended for use in the electromagnetic environment specified below. The customer or the user of the ME EQUIPMENT should assure that it is used in such an environment.			
Immunity test	IEC 60601 Test level	Compliance level	Electromagnetic environment – guidance
Electrostatic discharge (ESD) IEC 61000-4-2	± 8kV contact	± 8kV contact	Floors should be wood, concrete or ceramic tile. If floors are covered with synthetic material, the relative humidity should be at least 30 %.
	± 2; 4; 8; 15 kV air	± 2; 4; 8; 15 kV air	
Electrical fast transient/burst IEC 61000-4-4	± 2kV for power supply lines	± 2kV for power supply lines	Mains power quality should be that of a typical commercial or hospital environment.
	± 1 kV for the entry / exit lines	± 1 kV for the entry / exit lines	
Surge IEC 61000-4-5	± 1kV between the phases	± 1kV between the phases	Mains power quality should be that of a typical commercial or hospital environment.
	± 2kV between phase (s) and earth	± 2kV between phase (s) and earth	
Voltage dips, short interruptions and voltage variations on power supply input lines IEC 61000-4-11	0% U _T for 0,5 cycles	0% U _T for 0,5 cycles	Mains power quality should be that of a typical commercial or hospital environment. If the user of the ME EQUIPMENT requires continued operation during power mains interruptions, it is recommended that the ME EQUIPMENT be powered from an uninterruptible power supply or a battery.
	0% U _T for 1 cycles	0% U _T for 1 cycles	
	70% U _T for 25 cycles	70% U _T for 25 cycles	
	0% U _T for 250 cycles	0% U _T for 250 cycles	
Power frequency (50/60Hz) magnetic field IEC 61000-4-8	30 A / m	Not applicable, the device does not contain components susceptible to magnetic fields	Power frequency magnetic fields should be at levels characteristic of a typical location in a typical commercial or hospital environment
NOTE : UT is the a.c. mains voltage prior to application of the test level.			

Guide and declaration of the manufacturer - electromagnetic immunity

The ME EQUIPMENT is designed to work in the electromagnetic environment specified below. The client or user of the ME EQUIPMENT should ensure that it is used in this environment
 Portable and mobile RF communications equipment should not be used closer to any part of, including cables, than the recommended separation distance calculated with the equation applicable to the transmitter frequency.

Immunity test	Trial level of the IEC 60601	Level of compliance	Recommended separation distance d:
Conducted RF IEC 61000-4-6	3 V _{eff} from 150kHz to 80 MHz	3 V _{eff}	d= 30 cm
Radiated RF IEC 61000-4-3	3 V/m from 80 MHz to 2,7 GHz	3 V/m	d= 30 cm
Immunity to proximity fields from wireless RF communication devices IEC 61000-4-3	TETRA 400 380 – 390 MHz	27 V/m	27 V/m
	GMRS 460 FRS 460 430 – 170 MHz	28 V/m	28 V/m
	LTE Band 13, 17 704 – 787 MHz	9 V/m	9 V/m
	GSM 800/900, TETRA 800, iDEN 820, CDMA 850, LTE Band 5 800 960 MHz	28 V/m	28 V/m
	GSM 1800; CDMA 1900; GSM 1900; DECT; LTE Band 5 1700 – 1990 MHz	28 V/m	28 V/m
	Bluetooth, WLAN, 802.11 b/g/n, RIFD 2450, LTE Band 70 2400 – 2570 MHz	28 V/m	28 V/m
	WLAN 802.11 a/n 5100 – 5800 MHz	9 V/m	9 V/m

EME

ITALY

Italian manufacturer of physiotherapy equipment since 1983

EME Srl

Via degli Abeti 88/1, Pesaro (PU) 61122 ITALY

T +39 0721400791 - F +39 072126385 - info@eme-srl.com - www.eme-srl.com