



Miele Group
Member

User manual

ENDOSCOPES WASHER DISINFECTOR

EW 2/1

EW 2/2

Serial N°:

CE 0051



Miele Group
Member

Via Balegante, 27
31039 Riese Pio X (TV)
ITALY

Manufacturer: STEELCO S.p.A. Via Balegante, 27 - 31039 Riese Pio X (TV) - ITALY

CONTENTS

1. GENERAL RULES.....	7
1.1 LIMITS OF MANUFACTURER’S LIABILITY.....	7
1.2 MANUAL VALIDITY, CONTENTS AND CONSERVATION.....	8
1.3 REGULATIONS.....	9
1.4 ENDOSCOPE REQUIREMENTS.....	10
2. SAFETY INFORMATION	12
2.1 INTENDED USE, IMPROPER USE	12
2.1.1 APPLICATION FIELDS	12
2.1.2 VALIDATED CYCLES	13
2.2 IMPORTANT WARNINGS AND SUGGESTIONS	14
2.3 SAFETY RECOMMENDATIONS.....	15
2.4 ATTENTION	17
2.4.1 INLET WATER.....	19
2.4.2 RINSE WATER	20
2.5 RESIDUAL RISKS.....	22
2.6 SAFETY SIGNALS USED	24
2.7 TRAINING.....	24
2.7.1 STAFF QUALIFICATION	25
2.8 INDICATION OF SOUND LEVEL	26
2.9 TABLE OF SYMBOLS.....	27
3. UNIT CHARACTERISTICS	29
3.1 MACHINE COMPONENTS	29
3.2 CONSTRUCTION CHARACTERISTICS.....	30
3.3 ENVIRONMENTAL EMISSIONS	31
3.4 INSTALLATION.....	32
3.5 RE-INSTALLATION.....	32
4. INSTALLATION	33

4.1	REPLACEMENT OF CHEMICAL PRODUCT CONTAINER	34
4.2	WATER INTAKE FILTER INSTALLATION	36
4.3	CONNECTIVITY	38
5.	CHECKING THE PARAMETERS AND SCREEN PAGE FUNCTIONS ON THE MONITOR	38
5.1	MAIN MAINTENANCE AREA PARAMETERS	41
5.2	CLOCK AND DATE UPDATE	42
5.3	RESTORING THE PARAMETERS SAVED	44
5.4	MANUAL CONTROL OF THE MECHANICS	45
5.5	CYCLES HISTORICAL VISUALIZATION.....	56
5.6	PARAMETER CONFIGURATION.....	61
5.7	USER DATA CONFIGURATION	62
5.8	THERMALDISINFECTION CYCLE	72
5.9	SELF-DISINFECTION PROCEDURE WITH A 12% SODIUM HYPOCHLORITE SOLUTION	74
5.10	INSTRUCTIONS IN CASE OF EXTENDED MACHINE STOP	74
5.11	TABLE MANAGEMENT	75
5.11.1	ENDOSCOPE TYPE TABLE	77
5.11.2	MANUFACTURERS TABLE	79
5.12	OPERATOR SETUP.....	81
5.13	ENDOSCOPE SETUP	84
5.13.1	ENDOSCOPE CONFIGURATION PARAMETER SETTING	86
5.14	CREATING A BACKUP OF THE SETTINGS	94
5.15	UTILITY.....	95
6.	WASHING CYCLE.....	102
6.1	PREPARATION OF THE ENDOSCOPES.....	102
6.2	CHECK OF ENDOSCOPE INSTRUMENT CONNECTORS	103
6.3	START CYCLE.....	104
7.	PROGRAMMED MAINTENANCE	110
7.1	OPERATOR MAINTENANCE	110
8.	MACHINE ALARMS	113

8.1	TROUBLE SHOOTING	113
9.	DEMOLITION AND DISPOSAL	165
10.	QUALIFICATION	166
10.1	INSTALLATION QUALIFICATION (IQ)	166
10.2	OPERATIVE QUALIFICATION (OQ)	166
10.3	PERFORMANCE QUALIFICATION (PQ)	166
ANNEX A – TRAINING CERTIFICATE		169
ANNEX B – WATER SAMPLING DURING THE FINAL RINSING PHASE		170
ANNEX C – TEST PROCEDURE WHEN INSTALLING		180
ANNEX D – BARCODE READER SETTING		181
ANNEX E: SPECIFICATION OF ROUTER NAT PROGRAMMING		188

ATTENTION!!

THE PRESENT HANDBOOK HAS BEEN WRITTEN FOR TECHNICIANS AUTHORIZED

Thank you for purchasing this appliance.

The installation, maintenance and operating instructions given in the following pages have been prepared to ensure the long life and good performance of the appliance.

Following the instructions carefully.

The appliance was designed and constructed using the latest technological innovations available.
Please take good care of it.

Your satisfaction is our best reward.

WARNING:

NON OBSERVANCE, EVEN IN PART, OF THE RULES INDICATED IN THIS MANUAL WILL CAUSE THE PRODUCT GUARANTEE TO BECOME INVALID AND RELIEVES THE MANUFACTURER OF ANY RESPONSIBILITY.

1. GENERAL RULES

1.1 Limits of manufacturer's liability

The manufacturer shall not be held liable for failures or problems which arise due to tampering and/or incorrect applications and/or improper use of the machine.

The purchaser must comply with all instructions set forth in the user's manual, and he must in particular:

- Always work within the allowable limits for the use of the machine;
- Always carry out constant and diligent maintenance;
- Allow use of the machine by persons with proper skills and abilities for their role and purpose who have been properly trained and instructed;
- Use only manufacturer original spare parts.

Any modifications, adaptation or the like which may be made to machines which are subsequently placed on the market do not oblige the manufacturer to intervene on previously supplied machines, nor to consider the machine and the related user's manual lacking and inadequate.

The installation, maintenance and operating instructions given in the following pages have been prepared to ensure the long life and outstanding performance of the appliance.

For some especially demanding programming or maintenance operations, this manual serves as a memorandum of the main operations to be carried out.

Education on these topics can be obtained by attending training course held by the manufacturer.

The instructions in this manual do not replace but rather are in addition to employer requirements to adhere to current legislation on standards of prevention and safety.

1.2 Manual validity, contents and conservation

This manual reflects the state of the art at the moment of manufacture and delivery of the appliance and is valid for its entire life cycle.

The manufacturer is at clients' disposal for further information or to receive suggestions for making the manual more compliant with the needs for which it was prepared.

The translation of the contents into the client's language has been carefully prepared.

In order to prevent possible accidents to persons or property due to incorrect translation of the instructions, the client must:

- Not perform operations or manoeuvres with the machine if there are any doubts or uncertainties about the operation to be performed;
- Ask technical service for clarification of the instruction.
- If lost, ask for a new copy from the manufacturer.

It is important to keep this instruction manual with the machine for future reference.

If the machine is sold or transferred, the manual must be handed over to the new owners or user in order for them to become acquainted with its functioning and the relative warnings.

Read the warnings carefully before installing and using the machine.

This is a translation of the Italian text, which prevails in case of doubts.

1.3 Regulations

The purpose of the warnings is to safeguard the user in compliance with following Regulations and “Technical Product Standards”:

EUROPE:

- 93/42/EEC and s.m.i (Medical Devices Directive);
- 2014/35/UE (Low Voltage Directive);
- 2014/30/UE (Electromagnetic compatibility directive);
- 2014/68/UE (PED Directive);
- EN 61010-1 (Safety);
- EN 61010-2-040 (Safety);
- 2011/65/EC (RoHS II);
- 2012/19/EC (WEEE);

and recognized international standards:

- IEC 61000 (Electromagnetic compatibility);
- IEC 61326-1 (Electromagnetic compatibility);
- ISO 14971 (Medical devices risk analysis);
- ISO 15883-1 (General requirements, terms, definitions and tests);
- ISO 15883-4 (Requirements and tests for medical washer and disinfectors that carry out the chemical disinfection of flexible endoscopes);
- ISO/TS 15883-5 (Soil test – A soil test method to prove the effectiveness of cleaning activities);
- IEC 60529 (IP Grade);

Steelco declares that this product, when it is equipped with a water steam version, is in accordance with PED 2014/68/UE directive art. 4 par. 3 and it has been designed and built in accordance with the correct building procedure.

1.4 Endoscope requirements

*During PQ validation “Dummies” have to be considered as real endoscopes following the same criteria illustrated in point 1.4 Endoscope requirements.

The flexible endoscopes treated in the EW 2 system must fulfil the following requirements:

- Resistance to a temperature between +10°C and +60°C;
- Resistance of the endoscope channels to a maximum pressure of 1.5 bar;
- Resistance to a pressure of max. 0,3 bar during the leak test;
- Resistance to the detergents and disinfectants used;
- Presence of connections where to attach each of the endoscope channels;
- Waterproof with protection against the effects of immersion and, if applicable, equipped with parts that protect the endoscope from humidity.

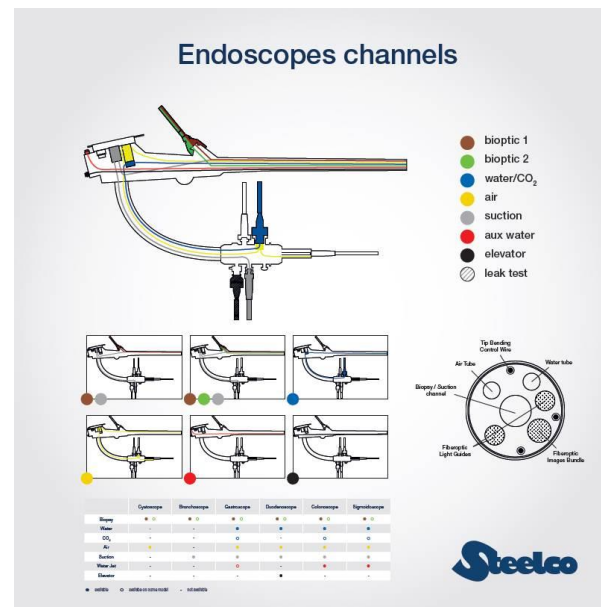

The colored code connection suggested in the figure above refers – but is not limited – to the majority of the endoscopes in the market.

During endoscopes calibration and setting, please check carefully each channel pressure and flow.

When the values detected do not allow the detection of obstructions or disconnections, a customized connection is needed.

When this happens, the color code identification (color – channel function) is not valid anymore, but the connection should be done based on the flowmeters' diameters and booster pumps. (See picture below).

Such a connection must be able to detect any obstruction or disconnection.

Moreover, every colored hose which is not needed, shall be connected to a flow reducer.

In case of need / doubts please contact the manufacturer.

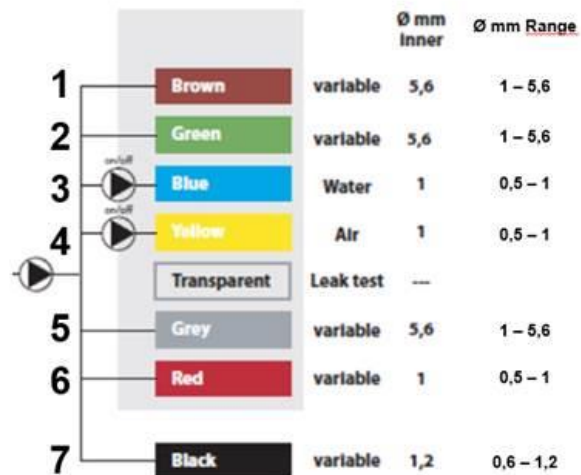

2. SAFETY INFORMATION

Compliance with safety standards allow the operator to work productively and calmly, without the danger of harming himself or others. Before starting work, the worker must be completely familiar with the functions and proper operation of the machine. He must know the precise function of all command and control devices of the machine.

2.1 Intended use, improper use

INTENDED USE:

The intended use of this device is washing and high level disinfection of thermolabile endoscopes by using only and exclusively the chemical agents approved and validated by the device manufacturer.

2.1.1 Application fields

The use of this device is intended for the treatment of the medical devices, such as:

- Flexible endoscopes
- Rigid endoscopes
- Transesophageal probes

2.1.2 Validated cycles

The high chemical disinfection cycles have been validated with the following chemical products:

HIGH DISINFECTION CYCLES	CHEMICALS
HYDROGEN PEROXIDE	SteelcoXide-DT (detergent)
	SteelcoXide-A (component A)
	SteelcoXide-B (component B)
PERACETIC ACID	Neodisher SC (detergent)
	Neodisher Septo PAC (peracetic acid)
GLUTARALDEHYDE	Neodisher SC
	Neodisher Septo GDA

Improper use of this unit may be hazardous to the operator and may seriously damage the machine itself.

WARNING: If the appliance is used in a manner not specified by the manufacturer, protection of the appliance may be compromised.

IMPROPER USE:

ANY USE OTHER THAN THAT FOR WHICH THE MACHINE WAS INTENDED IS FORBIDDEN.

2.2 Important warnings and suggestions

For proper use of the machine, and in order to safeguard employed staff, carefully comply with the following general and specific standards.

THE OPERATOR MUST:

- **Carefully adhere to the provisions and instructions** provided by the employer, managers and supervisors for individual and group safety.
- **Use safety devices appropriately and with care**, as well as group and individual safety gear provided by the employer.
- **Immediately inform the employer**, the manager and the supervisor of deficiencies in the aforementioned devices and means, as well as any hazardous conditions which he may become aware of, taking action directly in urgent cases within their scope of responsibilities and abilities to eliminate or reduce the deficiencies or hazards.

THE OPERATOR MUST NEVER:

- **Remove or modify, without authorization, the safety devices**, nor those for signalling and measuring, nor the individual and group safety gear.
- **Undertake on his own initiative operations or manoeuvres which are not his responsibility which** may compromise safety.
- **Insert foreign objects into the electrical parts.**
Do not insert foreign bodies into the covers of the electrical motors or into the moving parts of the machine.
- **Provide power to the machine by tampering with the main switch and the safety devices.**

2.3 Safety recommendations

- If the new machine seems damaged, contact the retailer before using it.
- Any modification of electrical and hydraulic systems necessary to install the machine must be carried out by qualified, authorised persons only.
- This machine must be operated by trained persons only;
- This machine has been designed for the reprocessing of flexible and rigid endoscopes, transesophageal probes and the thermal-disinfection of washing chambers;
- Any use other than that for which the machine was intended is forbidden.
- The user is forbidden to carry out any work or repairs on the machine.
- Technical Assistance for this machine should be carried out by qualified and authorised operators only.
- The equipment should be installed by authorised persons only.
- The electrical safety of machine is only guaranteed if it is connected to an efficient earth system.
- Take great care when handling detergents and additives: avoid contact, wear gloves, goggles and mask and act in compliance with the safety recommendations indicated by the manufacturer of the chemical products.
- Do not inhale the fumes produced by chemical products.

**WARNING: The chemical products are an irritant for the eyes, in case of contact rinse thoroughly with plenty of water and consult a doctor.
If these products come into contact to the skin, rinse with plenty of water.**

- The water in the tank is not drinking water.
- Do not lean on the door and do not use it as a step.
- Do not install the equipment in rooms where there is the risk of explosion (ATEX).
- Do not expose the equipment to intense cold.
- Do not wash the machine using high-pressure jets of water.
- The machine reaches a temperature of 80/90°C during the self-thermaldisinfection: take great care to avoid burns.
- Disconnect the machine from the electrical supply before carrying out maintenance work.
- The acoustic pressure of the machine is < 65 dB(A).

IMPORTANT WARNING FOR THE MAINTENANCE TECHNICIAN

LEAVE THE "Min.lim.water inconsistency" l.= 0.0 PARAMETER

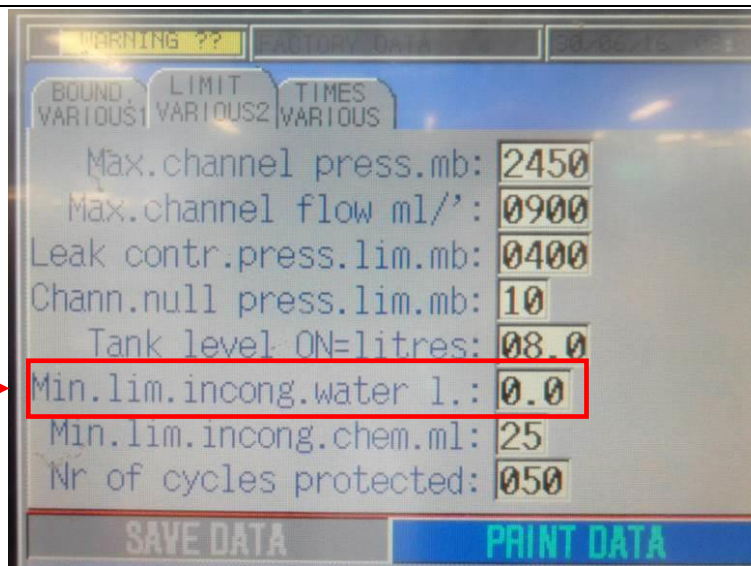



2.4 Attention

- The user must oversee the machine during the cycle.
- The injection tube for washing water must always be connected to the appropriated basket.
- When the machine is running do not interrupt the cycle since this jeopardises disinfection.
- Use only detergents and chemical additives that have been tested and approved by the equipment manufacturer; The use of other products may damage the machine and the correct reprocessing of the medical device and the cycle cannot be guaranteed or validated in accordance with standard ISO 15883.
- The use of opportune PPEs is compulsory in order to avoid contact with infected material and to prevent contamination during the handling procedures of medical devices to be reprocessed.
- The chemical products recommended by the manufacturer are those that have been certified and validated by ISO 15883:4 and 15883:5-TS standard.
- Check that type of chemical product is suitable for the specific washing program used.
- Comply with the instructions provided by the chemical product manufacturer.
- The machine was designed for use with water and chemical additives.
Do not use organic or other types of solvent as this may result in the risk of explosion or the rapid deterioration of certain machine parts.
- Residues of solvents or acids, particularly “hydrochloric acid”, can damage steel.
- Use original accessories only.
- Do never use soap powder.
- Do never use foaming detergent.
- The machine is to be used only with the accessories included by the manufacturer.
- Accessories which are not approved by the manufacturer may compromise the results achieved as well as user safety.
- Do never use chemical products based on chlorides (bleaches, sodium hypochlorite, hydrochloric acid and so on). These kinds of chemical detergents irreparably damage the machine and jeopardise the integrity of materials and objects treated.
- Check at every cycle the integrity of the connexions used to connect the endoscopes.
- The operator has always to verify before starting of the cycle the presence of the filters water in the sump and their correct positioning.
- Wet location.
- Mains supply voltage fluctuations: +/- 10%.
- Overvoltage category: II.
- Pollution degree: 2.
- IP: 00.

	ATTENTION
	IT IS NECESSARY TO START A THERMODISINFECTION CYCLE TO DECONTAMINATE THE MACHINE AT THE FIRST START OF MACHINE – SEE ANNEX C.

ATTENTION:

The taps of the water must be always turned off, as the safety and diagnosis system will be deactivated, in the following situations:

- If the machine is left unused;
- If the machine is disconnected from the electrical connection.

The Manufacturer cannot be held responsible for damage or injury caused by failure to observe the above rules.

The non-observance of these rules produces the total and prompt cancellation of the guarantee.

2.4.1 Inlet water

Physical Properties

Min. flow pressure	200 kPa (2,0 bar g)
Max. pressure	300 kPa (3,0 bar g)
Max. temperature	35° C
Max. hardness	7° f (70 ppm CaCO ₃)
Max. conductivity / Ph:	10 µS/cm

Chemical Properties

Heavy metal ions	Iron	min 0 mg/l (ppm)	max 2 mg/l (ppm)
	Manganese	min 0 mg/l (ppm)	max 2* mg/l (ppm)
	Copper	min 0 mg/l (ppm)	max 2* mg/l (ppm)
	Total heavy metal ions	min 0 mg/l (ppm)	max 10 mg/l (ppm)
Halides	Chloride	min 0 mg/l (ppm)	max 50 mg/l (ppm)
Others ionic contaminants	Phosphates (P ₂ O ₅)	min 0 mg/l (ppm)	max 0,2 mg/l (ppm)
	Nitrates (N _i)	min 0 mg/l (ppm)	max 20* mg/l (ppm)
	Silicates (SiO ₂)	min 0 mg/l (ppm)	max 2 mg/l (ppm)

Microbiological parameters

Parameter	Parametric Value
Escherichia coli	0/100 ml
Enterococci	0/100 ml
Pseudomonas aeruginosa	0/250 ml
Colony count 22 °C	100 CFU/ml
Colony count 37 °C	20 CFU/ml
Bacterial endotoxins	max 0,25 EU/ml

2.4.2 Rinse water

Physical Properties

Min. flow pressure	200 kPa (2,0 bar g)
Max. pressure	300 kPa (3,0 bar g)
Max. temperature	35° C max
Max. hardness	1,5° f (15 ppm CaCO3)
Max. conductivity / Ph:	10 µS/cm

Chemical Properties

Heavy metal ions	Iron	min 0 mg/l (ppm)	max 0,2 mg/l (ppm)
	Manganese	min 0 mg/l (ppm)	max 0,2* mg/l (ppm)
	Copper	min 0 mg/l (ppm)	max 0,2* mg/l (ppm)
	Total heavy metal ions	min 0 mg/l (ppm)	max 10 mg/l (ppm)
Halides	Chloride	min 0 mg/l (ppm)	max 10 mg/l (ppm)
Others ionic contaminants	Phosphates (P ₂ O ₅)	min 0 mg/l (ppm)	max 0,2 mg/l (ppm)
	Nitrates (N _i)	min 0 mg/l (ppm)	max 20* mg/l (ppm)
	Silicates (SiO ₂)	min 0 mg/l (ppm)	max 0,2 mg/l (ppm)

Microbiological parameters

Parameter	Parametric Value
Escherichia coli	0/100 ml
Enterococci	0/100 ml
Pseudomonas aeruginosa	0/100 ml
Mycobacterium Sp.	0/100 ml
Colony count	< 10 CFU/100 ml
Bacterial endotoxins	max 0,25 EU/ml

2.5 Residual risks

The appliance includes a series of fixed guards to prevent access to hazardous internal parts or zones.

It is however considered that the **EW 2** includes some residual risks.

Hereunder for each phase or significant work intervention are useful measures to be taken:

PHASE	BASKET LOADING
RISK	Contusions and cuts to the upper limbs , due to accidental contact with due to falling or striking against tools, objects and instruments, mainly while loading and handling the basket.
MEASURE	Assign staff that is instructed and equipped with work equipment (e.g. basket with protections, transport carts) and appropriate clothing and individual protection gear (e.g. shirts and protective gloves).

PHASE	MAINTENANCE OF INTERNAL EQUIPMENT
RISK	Burns of body parts by hot parts of the appliance.
MEASURE	Allow maintenance to be performed only by trained personnel, equipped with appropriate clothing and individual protection gear. Wear suitable clothing and protective gloves.

PHASE	EMISSION OF HAZARDOUS GAS
RISK	Inhalation of vapours of hazardous gas.
MEASURE	With a correct installation, concurring with the manufacturer prescription, using the authorized chemical product and concurring with the rules in force in your country, the machine doesn't generate hazardous gas. However, the machine is supplied with vapours discharge, that have to be connected concurring with the instruction on chapter 3.

PHASE	OBTAINING DETERGENTS/CHEMICAL ADDITIVES
RISK	Contact with body parts with chemical washing products.
MEASURE	Assign staff that is instructed and equipped with appropriate clothing and individual protection gear. Wear clothing, gloves, goggles and mask and act in compliance with the safety recommendations indicated by the manufacturer of the chemical products.
FIRST AID MEASURE	<ul style="list-style-type: none"> • Immediately take off/remove clothing which has been contaminated or soaked by the product. • If the substances come into contact with the skin, wash off affected skin areas immediately and rinse with water.
RISK	Inhalation of vapours of chemical wash products.
MEASURE	Assign staff that is instructed and equipped with appropriate clothing and individual protection gear. Comply with the safety instructions provided by the manufacturer of the chemical products and if there are none, wear a mask for the protection of the respiratory airways.
RISK	Accidental release of chemical wash product
MEASURE	Do not flush concentrate into drains, surface or ground waters. Collect spillage with adsorbent material (e.g. sand, earth, vermiculite, diatomaceous earth). Flush away minor amounts with plenty of water.
	IN CASE OF CONTACT WITH BODY OR RELEASE OF CHEMICAL PRODUCT LOOK ALWAYS AT THE SAFETY MEASURES INDICATED IN THE CHEMICAL TECHNICAL DATASHEET.

2.6 Safety signals used

To inform personnel operating on the machines of obligations of behaviour and residual risks, adequate safety signals (as set forth by 92/58 EEC) are applied to the machine and near the workplace.

GENERIC SAFETY SIGNALS:

In particular, labels with signals of obligation, prohibition and danger contained in this manual, and pertinent to this machine and most commonly used are:



Electrical risk



Warning!
See annex documentation



CAUTION
HOT SURFACE
Caution hot surface

INDIVIDUAL SAFETY WEAR:

The evaluation of risks for the health and safety of workers carried out in the workplace and on any equipment used, as well as the evaluation of residual risks as indicated, allow the employer to evaluate the need to adopt the individual protection gear which is most suitable and appropriate to be provided to workers.

Considering the type of machine, it is felt that the individual protection gear should be provided to staff.

2.7 Training

Instructions for use of the machine will be provided by the **STEELCO INSTALLATION TECHNICIAN** during the start-up phase to **MACHINE OPERATORS** and **MAINTENANCE TECHNICIANS** for their areas of responsibility, which will be thus instructed and trained. Moreover, an appropriate course certificate is issued (see Annex A).

It will be the duty of the **EMPLOYER** to check that the degree of staff training is suitable for assigned duties.

2.7.1 Staff qualification

Depending on the difficulty of certain installation operations, and of the operation and maintenance of the system, professional profiles are identified as follows:

Is INSTALLATION and REPAIR TECHNICIAN:

Specialized installation and maintenance staff capable of carrying out all machine positioning and installation operations, connection of various systems and machine start-up at the client's place of business, as well as all routine and special maintenance operations.

This operator is responsible for training staff for machine operation and for testing the machine.

As RESPONSIBLE AUTHORITY FOR THE MACHINE IN THE WORKPLACE:

Specialized staff assigned to the verification of safety devices and procedures for proper use of the machine in complete absence or hazards.

The responsible authority is personally responsible for training courses for staff assigned to machine operation and maintenance.

He must ensure that staff assigned to operation has acquired all information required for use and routine maintenance of the machine, registering attendance and documenting comprehension tests.

The responsible authority must have a perfect understanding of all command, control and safety devices of the machine.

He must inform all personnel assigned to machine operation and maintenance of the instructions concerning safety standards, the actions to be avoided and the first aid interventions connected with use of the machine and the chemical wash agents it contains.

The responsible authority must be aware of all correct procedures for carrying out in absolute absence of danger all operation and maintenance of the machine, as well as all procedures for disposal of any residual pollutants and manufacturing wastes.

He must always be present during extraordinary or routine maintenance and give his approval to proceed to staff assigned to operation or to personnel assigned to routine or special maintenance.

The responsible authority will be responsible for operation of all command, control and safety devices in the machines of the system.

He shall carry out scheduled verification of those devices in order to ensure their continued operation over time.

Ac MACHINE OPERATOR:

Skilled personnel assigned to machine operation.

The machine operator must be perfectly aware of all of the machine command and control devices.

Only after approval by the safety supervisor, the machine operator must be capable of using the assigned commands to do the following:

- Commissioning and start-up of the machine;
- Loading and unloading of material to be washed in the baskets;
- Operation of the machine in the various possible working modes, such as the start of various programmed wash cycles.
- Programming and setting data from the operator panel, adjustment of single control devices during working phases, starting or resetting of work functions.
- In addition, the machine operator must, by making use of all required individual protection gear and following adequate safety measures, be capable of performing some routine maintenance such as cleaning inside the machine, cleaning clogged filters, and disposing of pollutant waste materials produced during working.











2.8 Indication of sound level

The value shown refers to the measurement obtained on a machine of the same type as that covered herein and measured with an instrument at a height of 1,5 m at a distance of 1 m from the machine.

AVERAGE SOUND PRESSURE LEVEL: < 65 dB (A)

2.9 Table of symbols

Symbols installed on the machine:

	Electrical risk
	Warning - hot surface
	Manufacturer
	Manufacturing date
	Attention! See the enclosed documentation for important warnings, such as warnings and precautions.
	See instruction for use
	Protective conductor terminal
	CE mark issued by the notified body: 0051 identifies IMQ Indicated on the serial number label
	WEEE waste disposal
	Medical device indication
	It indicates the final product code of the medical device. It is reported in the serial number label. The "COD" corresponds to the article code in the system (AS 400) and in the sales invoice. This code can be variable depending on the model/specifications required by the customers. The machine model requested by the customer is in line with the model reported inside the technical

	documentation “DT-8051520DSXX2A” and in the DD-8051520DSXX2A medical device description document.
REP	Authorized Local Representative.
#	It indicates the model number of the product. It is reported on the serial number label.
UDI	It indicates the unique device identifier of the product. It is reported on the serial number label.

3. UNIT CHARACTERISTICS

3.1 Machine components

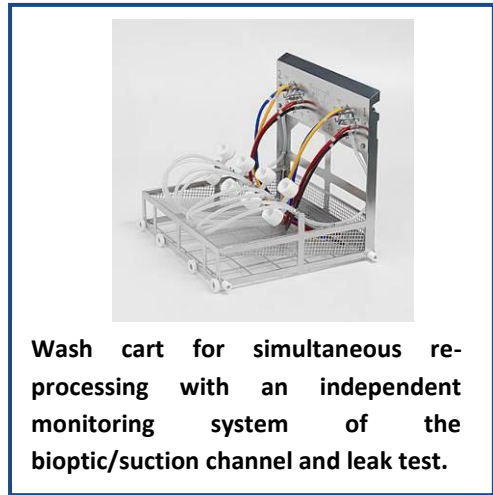
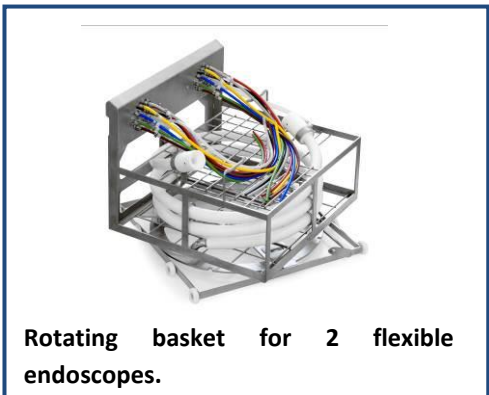
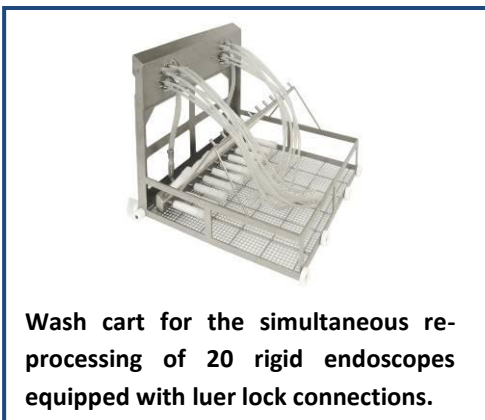

3.2 Construction characteristics

The typical construction characteristics of the unit are:

- pressed washing chamber with ample curves to facilitate the flow of chemicals;
- watertight washing chamber, thermally and acoustically insulated, with rounded edges, made of AISI 316L stainless steel. External body in AISI 304 stainless steel;
- hung access door in HTS glass, washing chamber, wash rotors, filters and internal circuits made of AISI 316L stainless steel;
- system to lock the door during the cycle and unlock it at the end of the cycle;
- water non-return system to prevent contamination of mains water (**UNI EN 1717**);
- 1 air pump (for testing endoscopes for leaks);
- possibility of treating endoscopes with 8 channels each (one channel for the leak test and 7 functional channels);
- possibility of treating indifferently 7 channels with a diameter greater or smaller than 1 mm for each endoscope;
- two stainless steel wash rotors in the chamber (plus a third in the middle of the basket);
- chemical disinfection (using peracetic acid diluted to 0.15%) at a temperature of 35°C for rigid and flexible endoscopes;
- chemical disinfection carried out at 55°C with peracetic acid diluted by 0.20%;
- **thermal self-disinfection (according to the EN ISO 15883-4 standard) at 80°C for 10 minutes or at 90°C for 3 minutes;**
- temperature control with 3 PT 1000 probes (plus one for drying version);
- control of pressure and flow for each channel of each endoscope;
- equipped with 3 adjustable Teflon dosing pumps for chemicals;
- checking for the presence of chemicals with RFID;
- double check of the quantity of chemical/disinfectant introduced;
- double check of the quantity of water introduced;
- control of the sealing phase before starting and during the entire treatment cycle;
- touch-screen control system with display of the single phases of the wash cycle, showing the time left;
- complete self-diagnosis system to facilitate technical service;
- 200 programs can be stored;
- 500 endoscopes can be stored;
- 20 different endoscopes manufacturer;
- 40 different endoscopes type;
- stores the last 800 cycles completely (all data of all the machine sensors are collected);
- total control of the cycle phases, time, temperature, chemical dosing, pressure range on the channels, quantity of water, drying;
- acoustic alarms for malfunctions and end of cycle;
- cycles stored with the events recorded (made available via an RS 232 connection, network port or USB port);

- set up for connection to the local Ethernet;
- 3 Password levels to access programming;
- touch-screen display with complete info on machine functions;
- dual filter system for inlet water (the first is 0.45 micron and the second 0.1 micron, absolute filter, medical device, 0.1 micron, the filter stops bacteria entering up to 10^{12} . The filter is positively charged for removing the endotoxins);
- compressed air filtering system at 0.2 micron, able to guarantee absolute sterility of the process (optional – connection to medical air required);
- 0.2 micron filter leak test;
- possibility of setting a time for the self-disinfection cycle to be done automatically;
- automatic traceability system (optional software – Steelco Data or ARES);
- Independent Double control PLC;
- possibility of computerising the treatment process by means of operator and/or endoscope identification using barcode scanners and/or transponder scanners.

3.3 Environmental emissions

The closed-circuit System has no significant environmental emissions and any emissions there may be when changing the tanks are not toxic or harmful to man. However, the System has a fitting for the forced evacuation of the fumes from the chemical tanks and from the high disinfection process. This fitting is at the back in the case of a single-door unit and on top in the case of the through model and is supplied with a hose about 30 cm long (on request) for connecting to the extraction hood (if applicable).

3.4 Installation

- The endoscope washer is delivered after several tests that guarantee the correct functioning of the machine. However, before using it, it is necessary to record the various flexible endoscopes type used and their features.
- Each endoscope will be codified (manufacturer, identification number, number and type of the channels, type of associated cycle, etc.) and the appropriate pressure and flow rate values will be associated to each one.
- These values can be insert manually or using a self-learning function; another way is to use the standard parameters of an instrument, copying from one of the instruments on the list, copying it in a new position and deselecting the channels don't used.
- During the next treatment cycles execution, if any set value is different from the real value the machine shows an anomaly (leak form the channels, disconnection from the endoscope circuit, etc).
- The external panels have always to remain closed.
- The data of the pressure and flow rate values of the different channels have to be inserted before the first use of the endoscope and have to be checked with a test cycle after the endoscope standard/special maintenance.
- The installation qualification, the operative qualification, the performance qualification and the periodical following qualification are assigned to the user. **An annual Performance Qualification (PQ) is recommended.**
- All the qualification test has to be documented, approved and preserved from an appointed person before the endoscope washer use.
- All the procedures for the routine test execution, included the verifications, check and the materials to be used, have to be documented.
- All the procedures for the standard maintenance of the endoscope washer and for the check operations of the validated cycles performance reproducibility, have to be documented.
- PQ and OQ protocols are available only upon request.

3.5 Re-installation

The machine can be moved from the installation site and be installed again in a new one only if this operation will be done following the same method and watchfulness of the first installation and from qualified personnel, including the documentation as on the first installation (installation test).

The new installation site has to be communicated to the Manufacturer/Distributor or other in accord to the prescription of the Directive 93/42 CEE.

ATTENTION: PLEASE CONSULT ANNEX C IN THIS MANUAL.

4. INSTALLATION

The system uses specific chemical compounds designed to obtain properly reprocessed devices, therefore any other type of chemical compound will not guarantee these results or its compatibility with the machine.

Standard machine accessories are 3 pumps for dosing the chemicals and 6 flowmeters (two for each chemical in order to have better control of the process). A dosing unit is dedicated to the detergent, another to the chemical disinfectant and a third one to a different type of chemical, for example using a bicomponent disinfectant or rinse aid. The fourth chemical is available as an optional. The chemicals dispensing system consists of tanks of product (those supplied by the Manufacturer), suction devices, pumps and flow meters.

- Check the technical data sheets of the chemicals used and do not exceed the recommended concentrations.
- Comply with the instructions given on the technical data and safety sheets for the environment and on storage methods.
- The unit checks that there are chemicals at each cycle (the presence of detergent is checked by a level sensor and RFID control while the peracetic acid is checked by a scale and RFID control). A warning is given if no chemicals are found.
- Access to the chemicals is only allowed when they need replacing and is to be done when the unit is in the no-cycle condition and by using PPE devices.
- The topping up or pouring of chemical from one tank to another is not allowed; by means of RFID technology, the system checks the batch, the expiry date and the original quantity of such chemical, therefore blocking any attempt to use combinations of different or expired batches and /or to carry out any top-ups.
- Before ever replacing chemicals, wear suitable personal protective gear; use extreme caution and carefully read the technical data and safety information sheets of the chemical in question.
- Chemicals must only be replaced by personnel who have been instructed about their inherent risks.
- Chemicals can be flammable. Refer to the instructions in the technical data and safety information sheets of each product.
- The unit's performance is subject to the use of chemicals supplied by the Manufacturer of the unit. The Manufacturer cannot guarantee that the unit will provide the same performance with different products.

4.1 Replacement of chemical product container

To replace the chemical product container perform the following procedure:

For the chemical product replacement, it is better to move the product container out of the machine.

- Take the new product container and open the chemical compartment.
- Replace the chemical product container removing the level sensor from the empty tank and put into the new one.
- Close the topper of the chemical product container and place it in the area for the storage of chemical substances.
- Close the chemical compartment.



	ATTENTION
	<p>The chemical product that is used is dangerous if touched or inhaled. Before the use, read carefully the safety information supplied by the manufacturer of the chemical product and the label on the package.</p> <p>During the operations of replacement of chemical product container, use the appropriate tools for individual protection (chemical protective gloves, face masks for breathing, etc.).</p> <p>The access to the technical compartment, where are located the chemical product containers, is permitted only with keys and to the authorized personal.</p>

4.2 Water intake filter installation

1. Assemble and fasten the 0.45 μm filter onto the right coupling, making sure that the arrows on the filter are facing upwards;

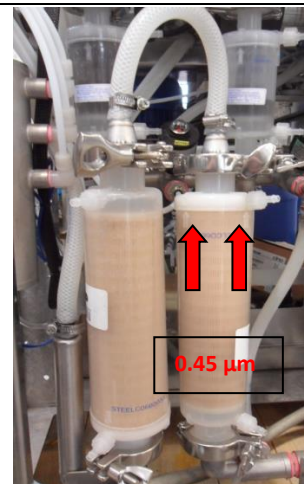

2. Assemble and fasten the 0.1 μm filter onto the left coupling, making sure that the arrows on the filter are facing downwards;

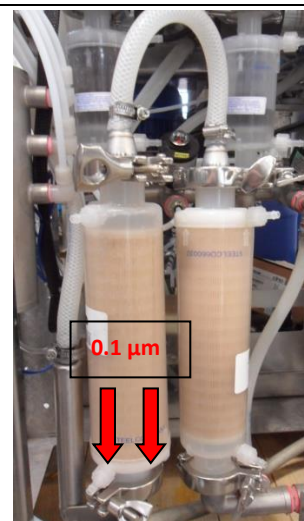

3. Connect the 2 filters by using the pipe supplied;

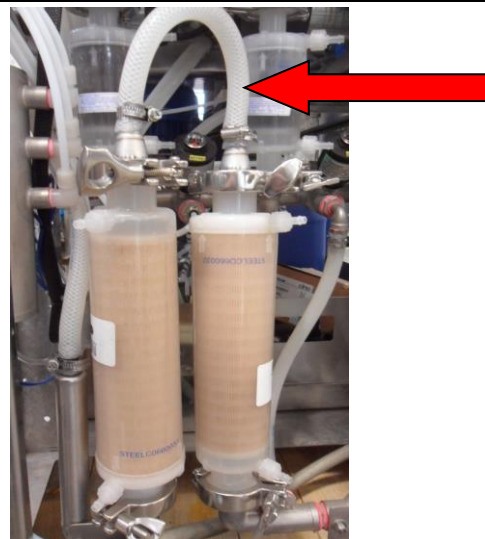

4. Assemble and fasten the 3 x 45 µm filters, making sure that the arrows are facing upwards;

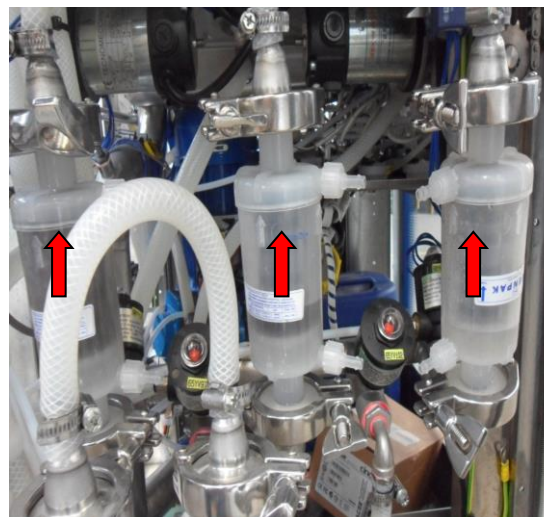

4.3 Connectivity

This device is equipped with a router NAT, which allows the connection to an external network. This device allows to provide just an IP address to the device, on which you must forward all the requests addressed to itself. That IP address is associated to the door marked by the *internet* sign. The door 1 (*internet*) must be connected to the customer network, mentre while the doors from 2 to 5 are reserved for the internal network to the device. The network data configuration inside the router is performed just with the software provided by Steelco. (Please see the Specification of Router NAT programming inside annex E).

5. CHECKING THE PARAMETERS AND SCREEN PAGE FUNCTIONS ON THE MONITOR

Control panel (Loading side)

The control panel is composed of a “Touch-screen” monitor and a membrane keypad with six setting keys. The monitor, depending on the programme/management status position, displays keys that can be selected by pressing the display area and which control specific control functions.





For the 6-key keypad, the functions are the following:

REFERENCE	DESCRIPTION
1	Selection for the access to functions for the adjustment of monitor display parameters: <ul style="list-style-type: none"> • Contrast • Brightness • Etc.
2	Always goes back to the previous page.
3	Always goes back to the main menu.
4	Reset the acoustic alarm signal.
5	Door closing.
6	Door opening .

Control panel (Unloading side - if present)

The control panel is composed of a “Touch-screen” monitor with the setting keys that allow to open/close the unloading door and reset the alarms.

Emergencies and checks

	<p>MAIN POWER SUPPLY SWITCH (optional)</p> <p>The machine is equipped with a main ON-OFF switch (optional), located on the dirty side, which disconnects the electrical power supply from all the auxiliary controls.</p>
	<p>EMERGENCY PUSH BUTTONS (optional)</p> <p>The machine is equipped with two emergency buttons, not automatically reset kind:</p> <ul style="list-style-type: none"> • Nr. 1 emergency button located on loading side; • Nr. 1 emergency button located on unloading side (in case of machine with pass-through door). <p>The red coloured emergency push-button, is marked with the word “EMERGENCY”. It is located in an easily accessible area but sufficiently protected against accidental activation.</p>

The EW 2 system already has the basic parameters stored, entered during the final inspection and test in the factory; they are usually valid for the majority of installations and, therefore, do not need to be changed. If they do need changing, follow the instructions below:

PARAMETERS DISPLAYABLE WITH THE USER PASSWORD (GREEN)

Password: call Steelco for technical assistance

5.1 Main maintenance area parameters

Press the “**MAINTENANCE**” key on the main screen page to gain access to the menu

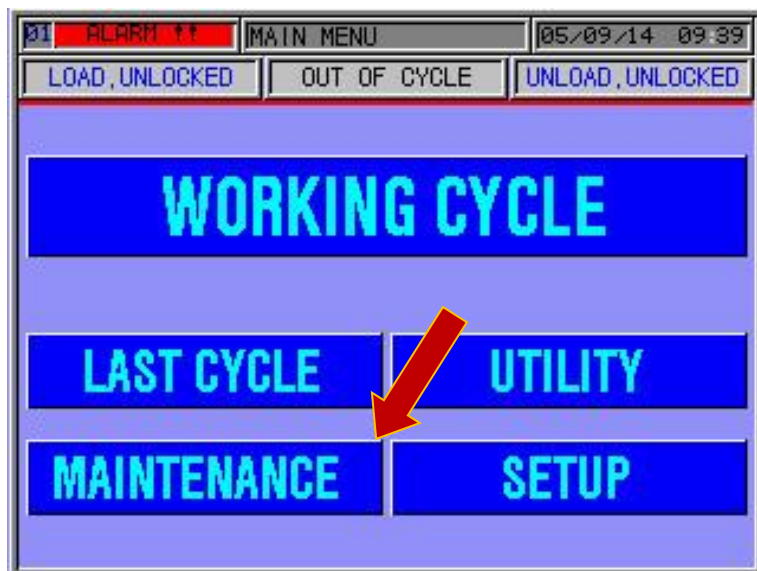

Pic. 5.3

Enter the user code.

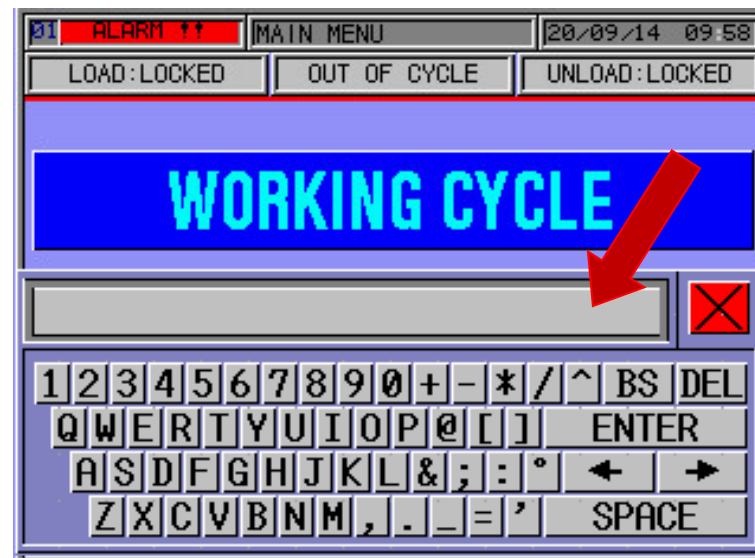

Pic.5.4

5.2 Clock and date update

To change the time and date press the “**CLOCK UPDATE**” key.



Pic. 5.5

Now press on the values to change and change them on the keypad that appears (sequence from Pic.5.6 – 5.7 – 5.8.).

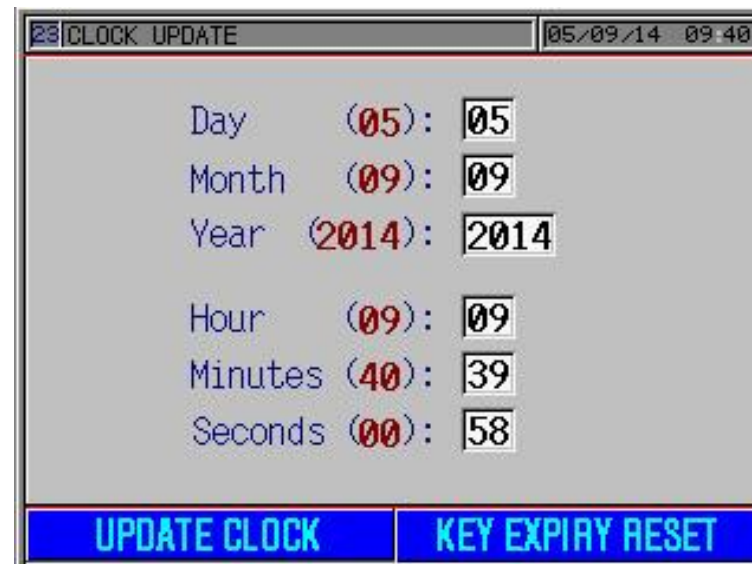

Pic. 5.6

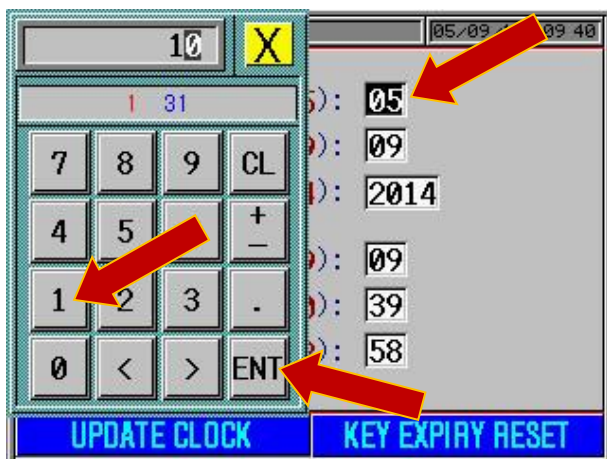

Pic. 5.7

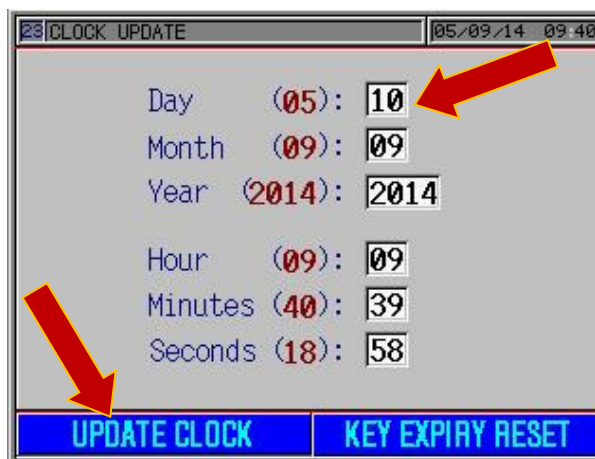

Pic. 5.8



5.3 Restoring the parameters saved

To restore the backup parameters, press the “**RESTORE**” key on the menu.

Press “**RESTORE**” to restore the data saved or “**MANUFACT. RESTORE**” to restore the factory default parameters; confirm and wait. If ok press

 to go to the previous page. Repeat if not ok.



Pic. 5.9

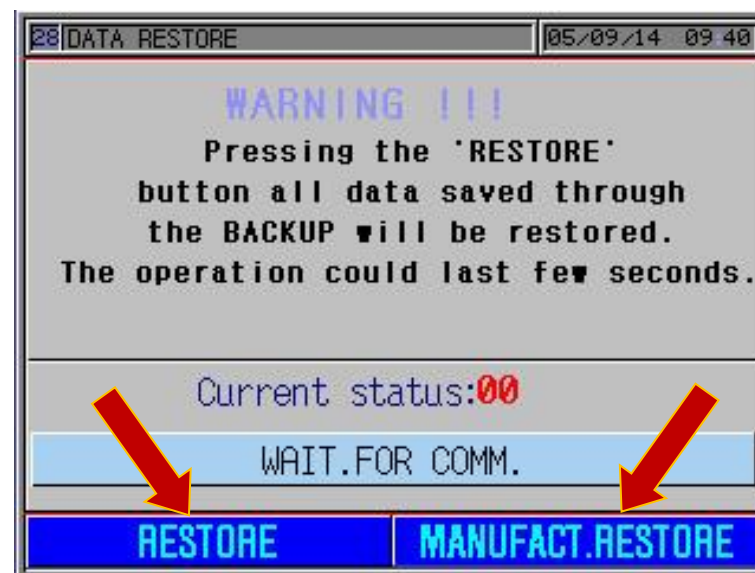

Pic. 5.9

5.4 Manual control of the mechanics

To operate the EW2 system manually press “**MAN.CONTROL**” on the menu.



Pic. 5.11

System status can be seen in the first screen page that appears (Pic.5.12 system working properly) and it is possible to go from the automatic to the manual phase by pressing on the word “**AUTOMATIC**”.

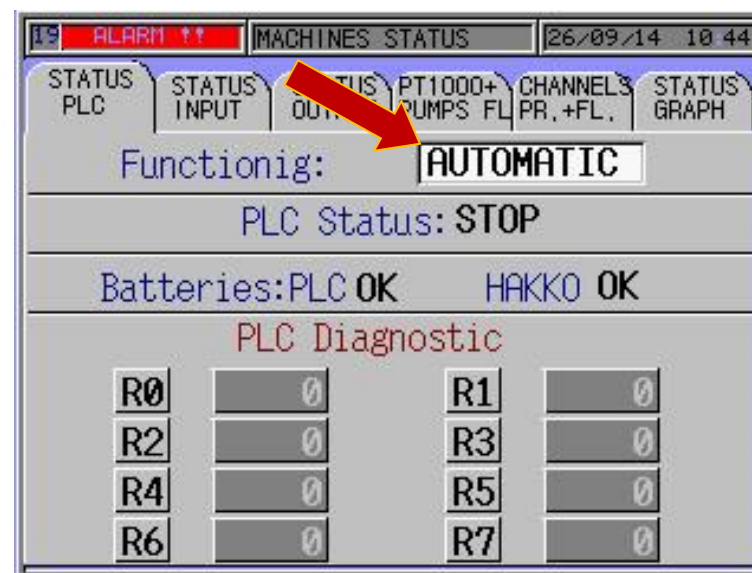

Pic. 5.12

The various “FUNCTION” screen pages can be scrolled by selecting the indexes at the top of the page.

Whether working in the manual or automatic mode, this screen page lets you see the status of the system’s inputs; a green led on corresponds to an active input to the PLC.

Whether working in the manual or automatic mode, this screen page lets you see the status of the outputs; a red led on corresponds to an active output from the plc while in the manual mode it is possible to activate or deactivate the corresponding function and test it (e.g. no. 177, the pump starts by pressing on “DRAIN PUMP”).

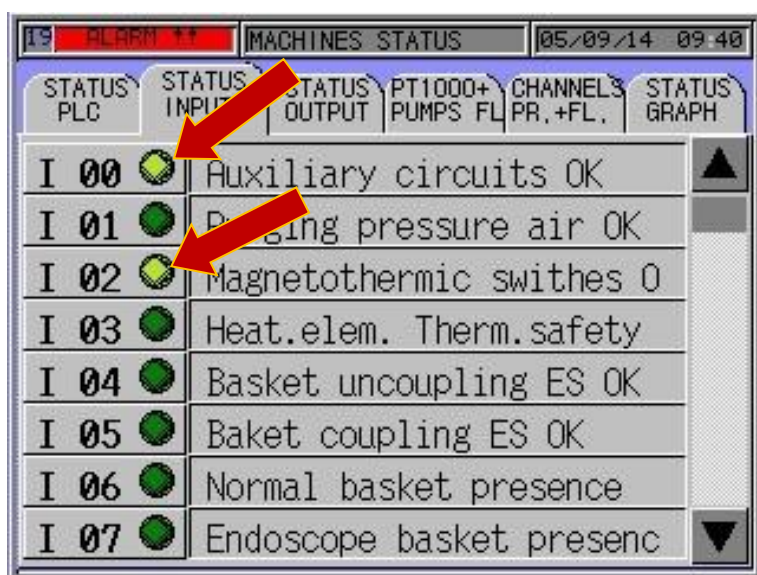

Pic. 5.13

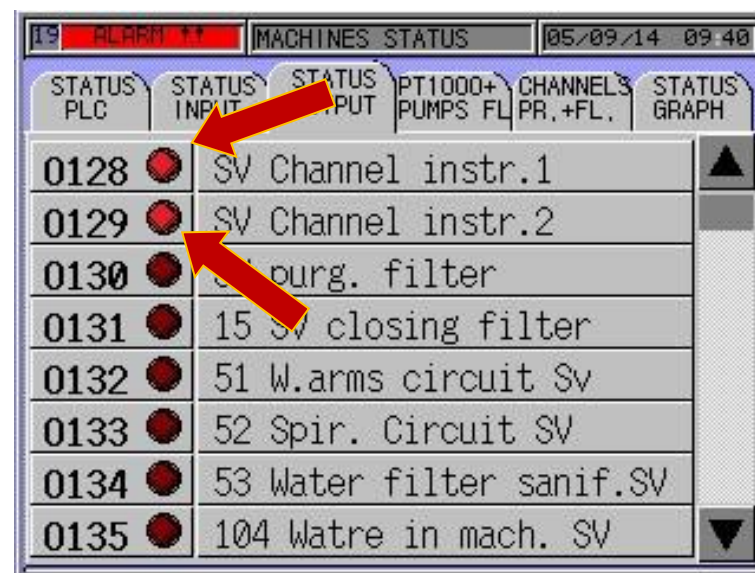

Pic.5.14

Whether working in the manual or automatic mode, this screen page lets you see the temperature of the system’s probes, the water conductivity and quantity in litres/min on the rotors. The purpose of the value by the side of the chamber temperatures, manually variable, is for setting the temperature of the chamber’s heating elements to be activated on the “**STATUS GRAPH.**” screen page by pressing on the drawing of the heating elements. this of course after having put at least 12 litres of water in the chamber. This function is normally used only to bring the chemicals up to the right temperature for manually washing the chamber (anti-limescale).

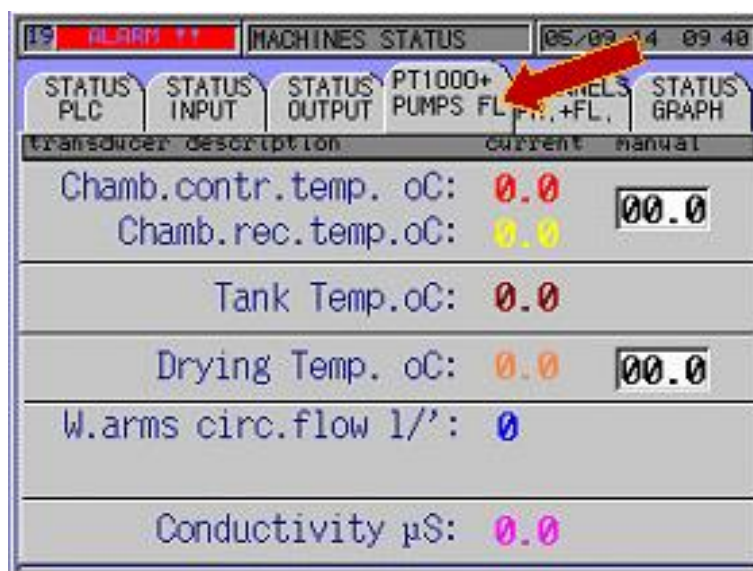

Pic. 5.15 - “PT1000+PUMPS FL”

Whether working in the manual or automatic mode, this screen page only lets you see the status of the pressures and flows in real time inside the channels connected and the leak test.

By pressing on the arrow at the bottom right you go from the pressure to the flow screen page.

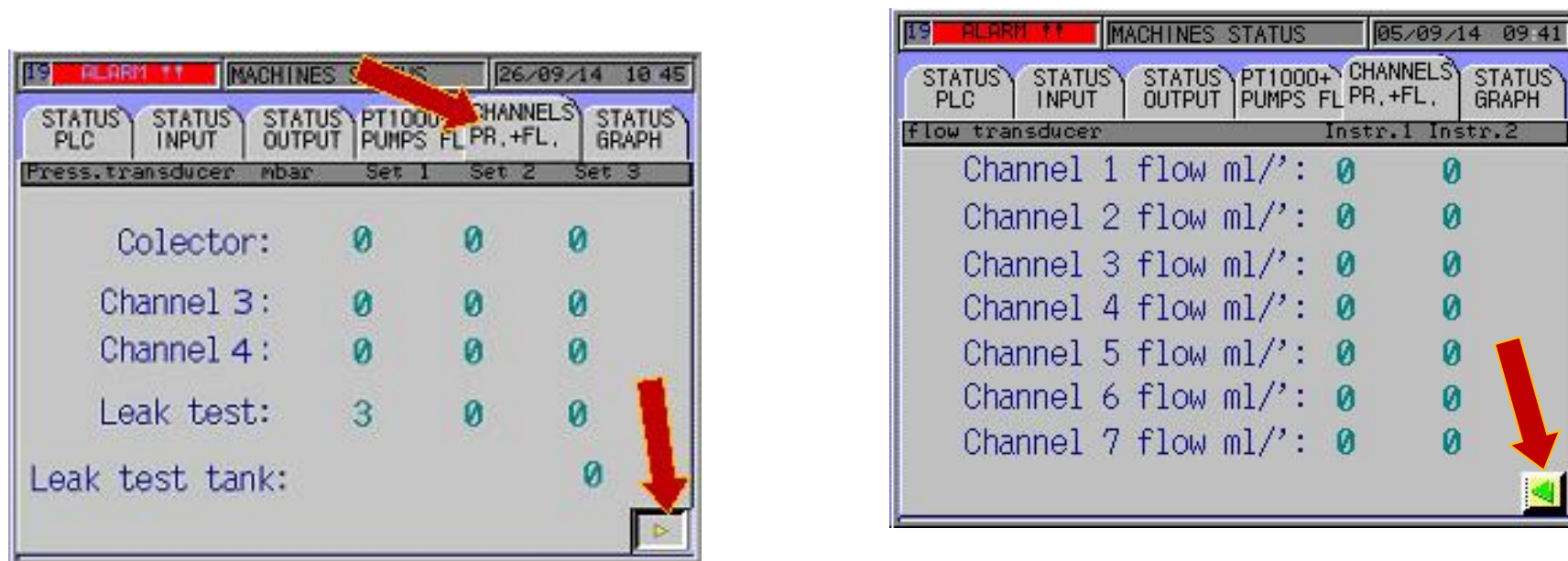

Pic.5.16 – Pic.5.17 “CHANNELS PR.+FL.”

With this screen page you can interact with the system manually. Here it is possible to manually activate or deactivate a series of pumps, valves and heating elements, displaying their values. Another 4 control screen pages can be accessed from this one: on the left “LEAK/ PURG.” PIC. 5.19, on the right “WATER/CHEM.” PIC. 5.20, below “DRAINS PUMP”/COMPRESSED, AIR” PIC.5.21, above “CHANNELS” PIC. 5.22 – (see table).

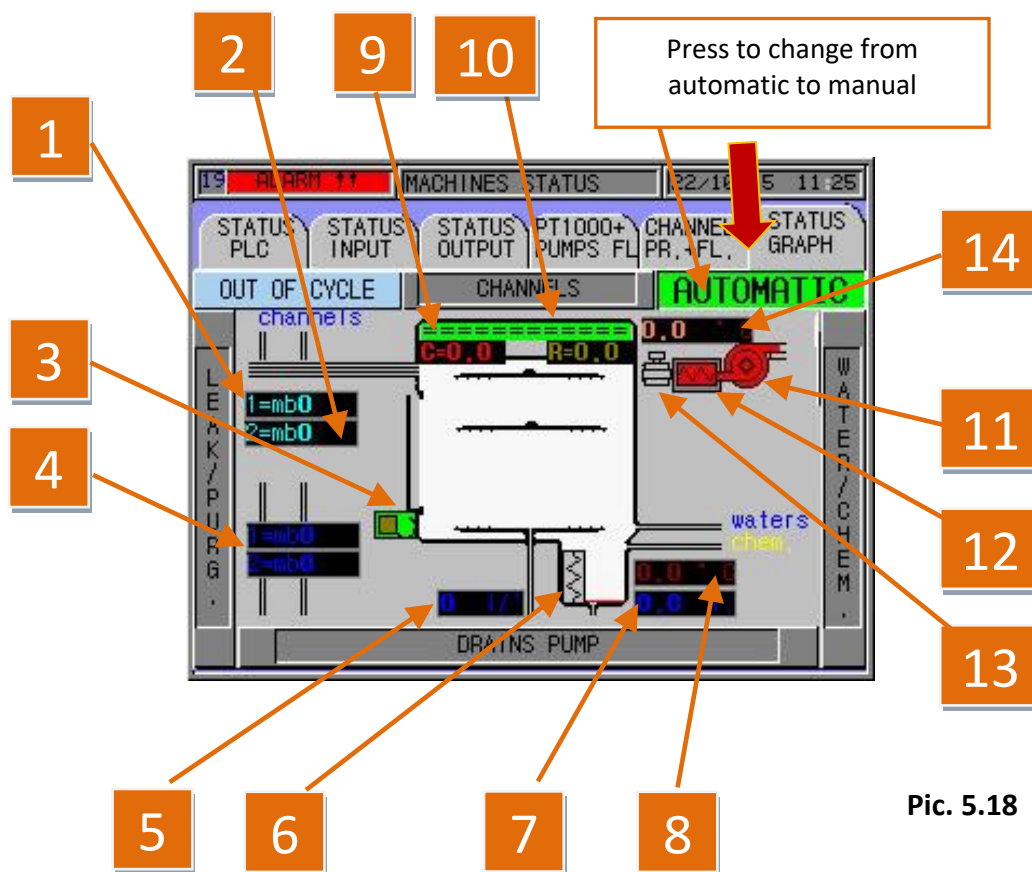

REFERENCE	DEVICE
1	Leak test pressure instr.1
2	Leak test pressure instr.2
3	Basket lock
4	L/Min. spiral/w.arm water
5	L/Min. w.arm water
6	Chamber heating elements
7	Quantity of water in the washing chamber
8	Machine cold point temperature
9	Chamber temperature control sensor
10	Chamber temperature adjustment sensor
11	Drying blower
12	Drying heating elements
13	Chamber opening valve for drying
14	Blower temperature

Pic. 5.18

With this screen page you can interact with the system manually. Here it is possible to manually activate or deactivate the valves and pump for the leak test and for flushing to conduct the tests, displaying the values. Another 3 control screen pages can be accessed from this one: on the right **“MACHINE.”** – PIC. 5.18, below **“DRAINS PUMP”/“COMPRESSED AIR”** PIC.5.21, above **“CHANNELS”** PIC. 5.22 – (see table).

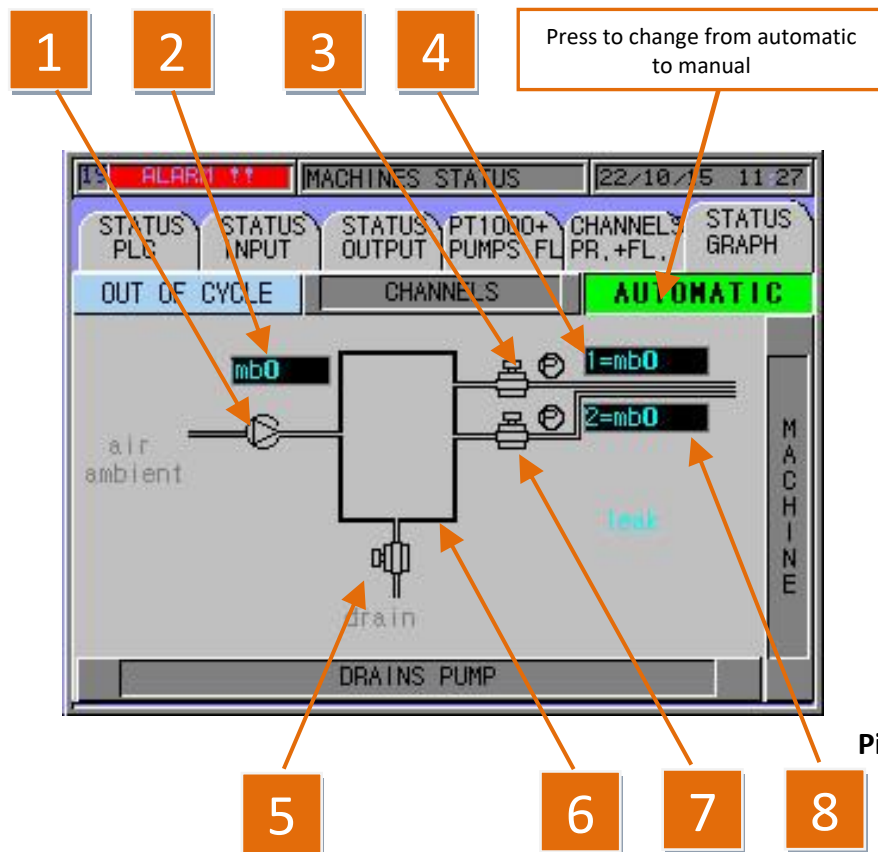

REFERENCE	DEVICE
1	Leak test pump
2	Pressure value of leak test pump
3	Air loading valve of instrument 1
4	Instrument 1 pressure value
5	Air draining valve of leak test cylinder
6	Leak test cycl.expansion
7	Air loading valve of instrument 2
8	Instrument 2 pressure value

Pic. 5.19

With this screen page you can interact with the system manually. Here it is possible to manually activate or deactivate the valves and chemical pumps for conducting tests, displaying the values. Another 3 control screen pages can be accessed from this one: on the left **“MACHINE”** – PIC. 5.18, below **“PUMPS/DRAIN”** – PIC.5.21, above **“CHANNELS”** – PIC. 5.22 – (see table)

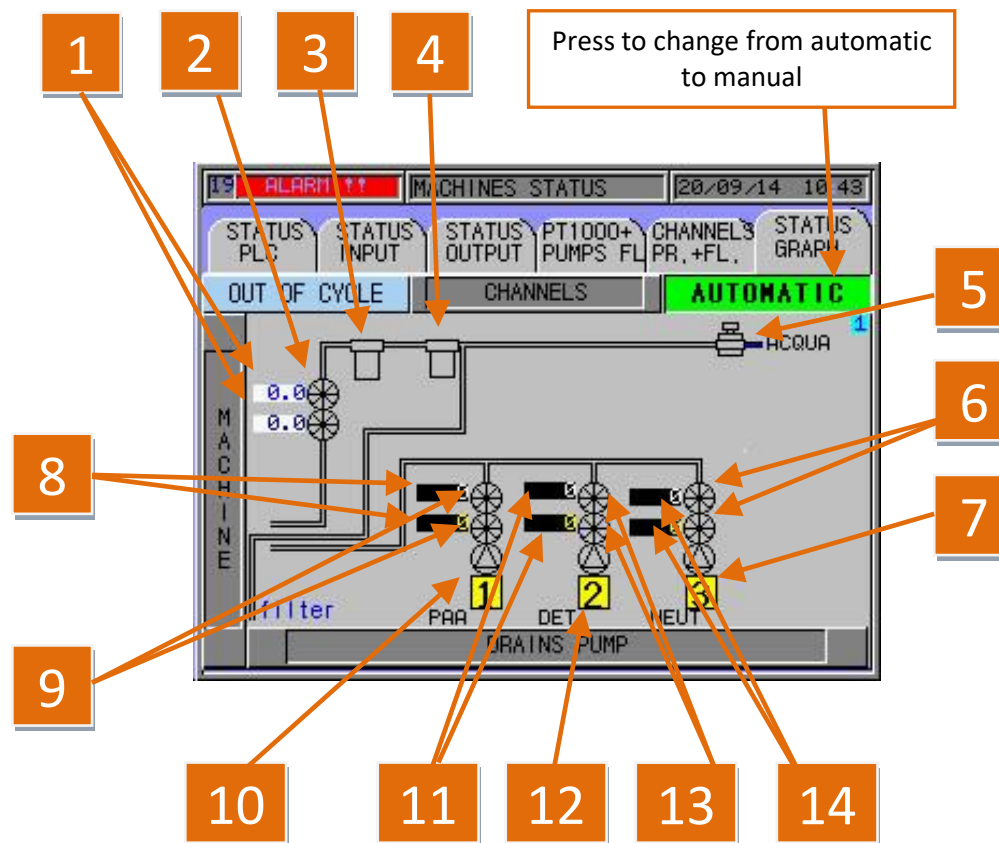

Pic. 5.20

REFERENCE	DEVICE
1	Displays of the quantity of water at inlet to the chamber (dual control system)
2	Flowmeters to control water loading in the chamber (dual control system)
3	0.1 micron water filter
4	0.45 micron water filter
5	Mains water filling valve
6	Chemical 3 loading control flowmeters (optional – dual control system)
7	Chemical 3 load pump (optional)
8	Displays of the quantity of chemical 1 (disinfectant) at inlet to the chamber (dual control system)
9	Flowmeters to control chemical 1 loading (disinfectant) in the chamber (dual control system)
10	Chemical 1 loading pump (disinfectant)
11	Displays of the quantity of chemical 2 (detergent) at inlet to the chamber (dual control system)
12	Chemical 2 loading pump (detergent)
13	Flowmeters to control chemical 2 loading (detergent) in the chamber (dual control system)
14	Displays of the quantity of chemical 3 (NEUTRALISER/ACTUATOR) at inlet to the chamber (dual control system)

With this screen page you can interact with the system manually. Here it is possible to manually activate or deactivate the valves and pumps that interact with chamber draining, spirals and w.arms, and the spurg with compressed air and channels, for conducting tests, displaying the values. Another 3 control screen pages can be accessed from this one: above **“MACHINE.”** – PIC. 5.18, left **“LEAK/PURG.”** – PIC.5.19, right **“WATER/CHEM.”** – PIC. 5.20 – (see table).

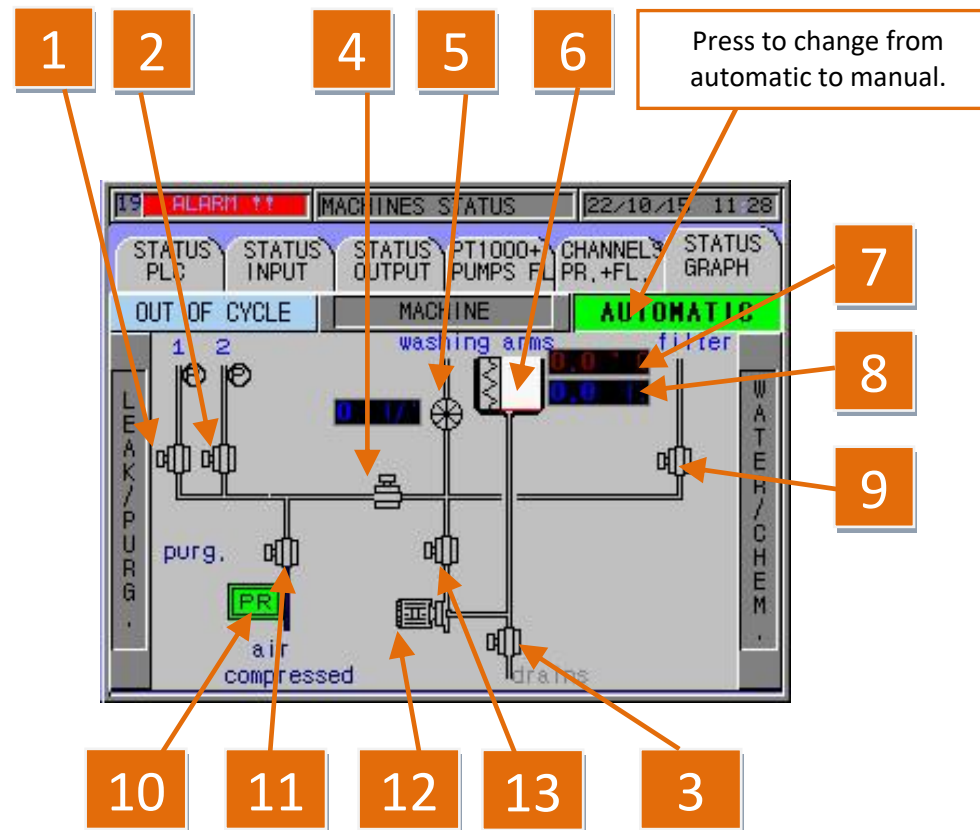

Pic. 5.21

REFERENCE	DEVICE
1	Channels valve purging of instrument 1
2	Channels valve purging of instrument 2
3	Pneumatic draining valve
4	Channel separation valve
5	Flowmeter to control washing arms water
6	Tank heating element
7	Displays of water temperature of tank
8	Displays of water quantity of tank
9	Pneumatic valve, sterilisation filter/supply water circuit
10	Pressure sensor of medical air
11	Purging valve
12	Recirculation pump
13	Pneumatic valve of recircular pump

With this screen page you can interact with the system manually. Here it is possible to manually activate or deactivate the endoscopic channel pumps for conducting tests, displaying the values. To activate them the spiral and rotor water valves must be active, the door(s) must be closed and the basket locking pistons active besides having the 12 litres of water in the washing chamber (if required for the tests). Another 3 control screen pages can be accessed from this one: under “**MACHINE**” – PIC. 5.18, left “**LEAK/PURG.**” – PIC.5.19, right “**WATER/CHEM.**” – PIC. 5.20 – (see table).

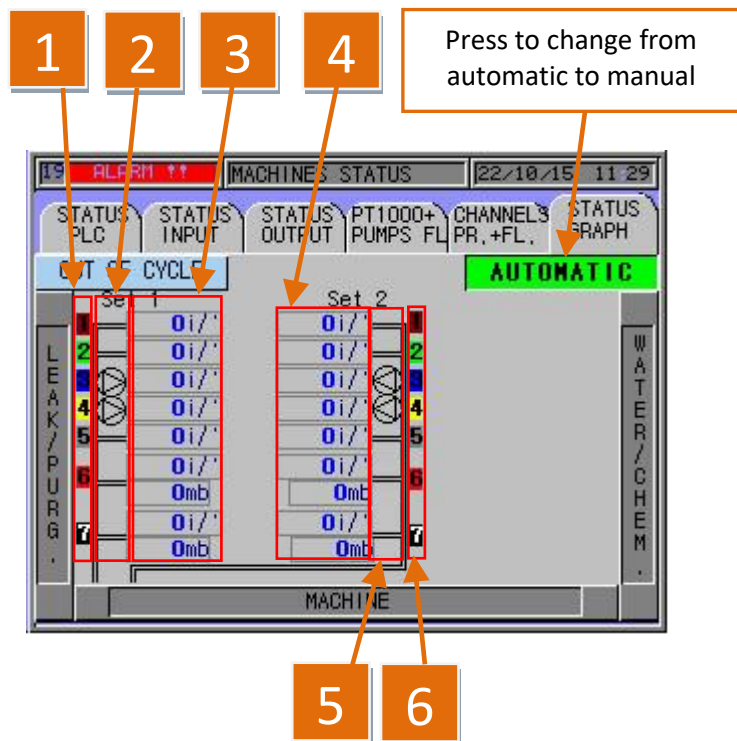

REFERENCE	DEVICE
1	Display of channels by colour, instrument position 1
2	Pumps channels 3 to 4 instrument 1
3	Display in real time of the channels flow of instrument position 1
4	Display in real time of the channels flow of instrument position 2
5	Pumps channels 3 to 4 instrument 2
6	Display of channels by colour, instrument position 2

Pic. 5.22

5.5 Cycles historical visualization

To display the “CYCLES HISTOR.” press the button with the same name on the “MANUAL CONTROL MENU”.

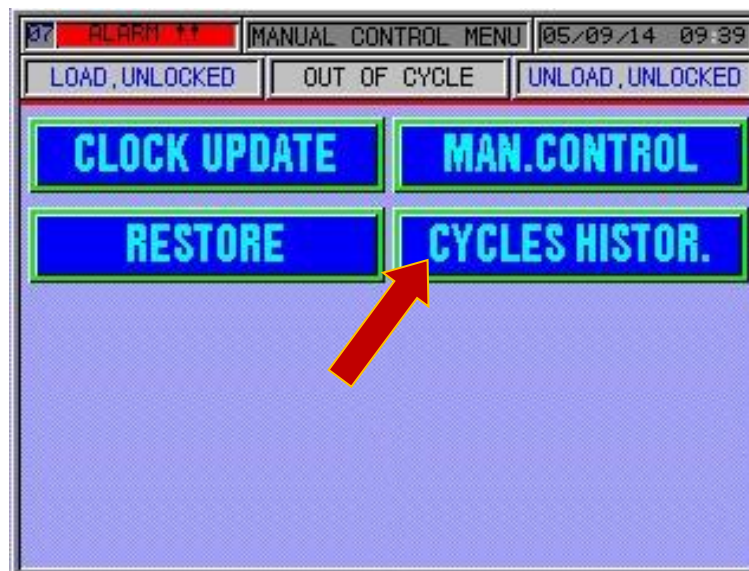

Pic. 5.23

There are two possible ways to search for cycles:

- Enter the data of the cycle(s) you want to display (point 1)
- OR**
- Enter the cycle number, if known, to display (e.g. if you want to display cycle 90 enter number 90 at points 2 and 3).

THEN PRESS THE “READ” KEY

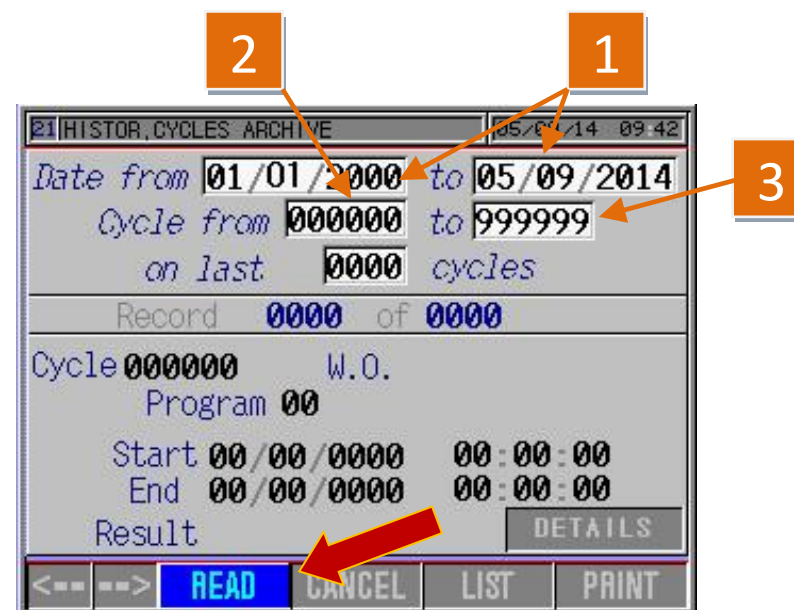

Pic. 5.24

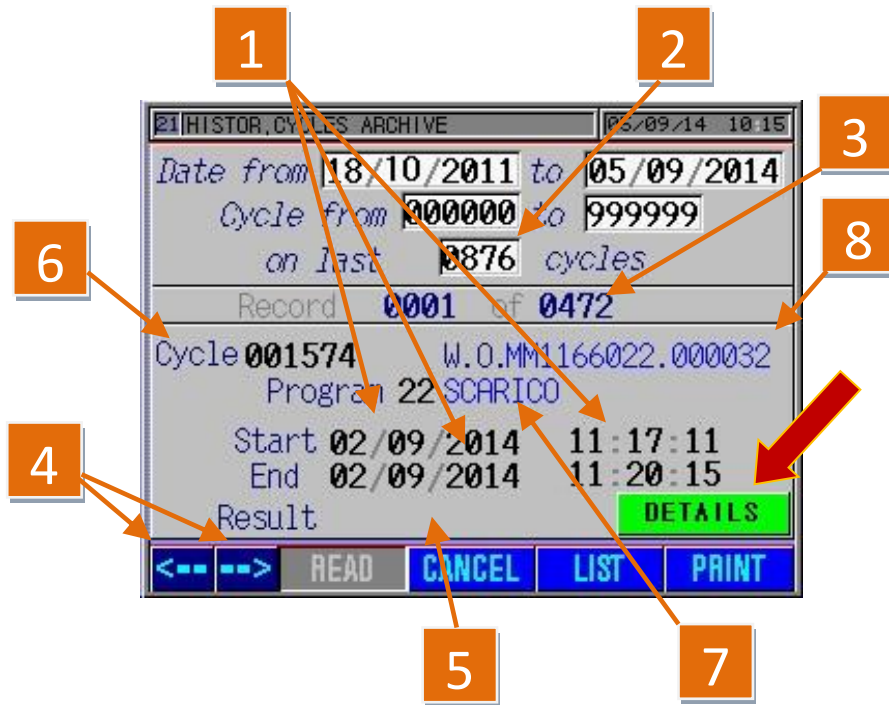

The screen page that appears will be like the one shown in figure 5.25. by selecting the cycle wanted, scrolling with the arrows (point 4) and pressing the “DETAILS” key, you will be able to see and print all the parameters of the cycle selected (see sequence in figures 5.26 and 5.27) in figure 5.25.

“CANCEL” key: press it to return to the screen page of figure 5.23.

“LIST” key shows a list of all the cycles found in the time period requested

“PRINT” key prints a list of the cycles found in the time period requested.

By pressing “DETAILS” button it is displayed the picture 5.26.

REFERENCE	DESCRIPTION
1	It displays the date and time of the start and finish of the cycle selected
2	It displays how many cycles have been carried out on the dates entered for the search
3	It displays the number in sequence of the cycle carried out on the dates entered for the search
4	Arrows to select the cycle
5	Result of the cycle selected
6	Number of the cycle selected (not the progressive number of the cycle)
7	Type of programme executed for the cycle selected

Pic. 5.25

All the parameters stored by the machine can be seen on this screen page (one set every 4 seconds – standard setting):

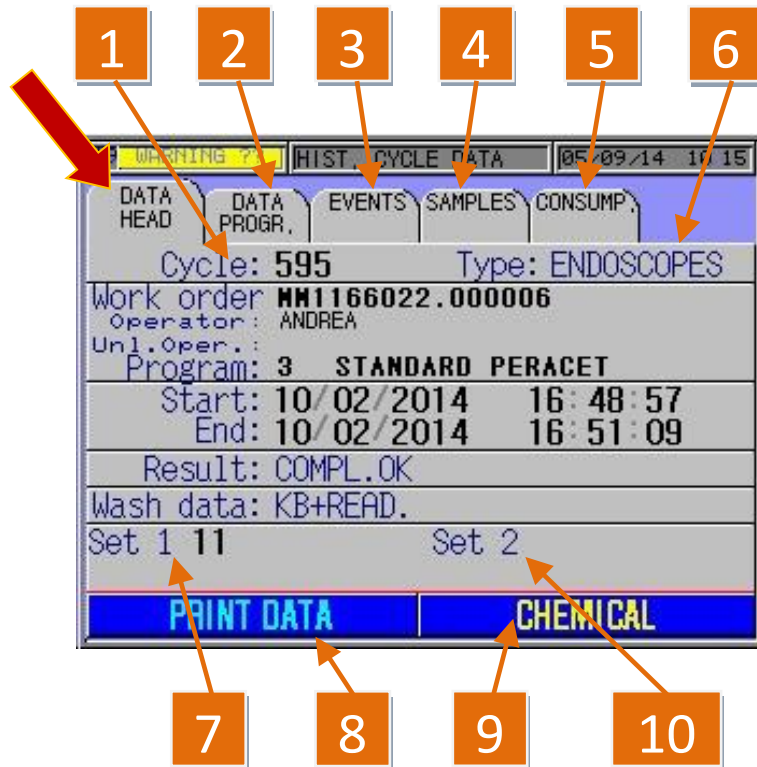

REFERENCE	DESCRIPTION
1	Cycle number (progressive).
2	“DATA PROGR.” it shows the sequence of the cycle phases.
3	“EVENTS” It shows all the events that occur in the cycle performed.
4	“SAMPLES” it shows sampling time and the two chamber temperatures.
5	“CONSUMPT.” it shows the consumption of water and chemicals during the cycle.
6	Type of material used for the cycle.
7	Serial number and model of the reprocessed instrument.

TO CREATE A PRINTOUT OF THE CYCLE PRESS THE “STAMPA DATI” BUTTON (POINT 8) AND PROCEED AS IN FIGURE 5.27.

By pressing the “CHEMICAL” button (point 9) you can see the activation status of the control rfid for the chemicals during the cycle, (point 10) data position second instrument (in the example given the cycle did not have the second instrument in the chamber).

Pic. 5.26

You can select what you want to print on this screen page; by touching the corresponding white boxes you can print the following information:

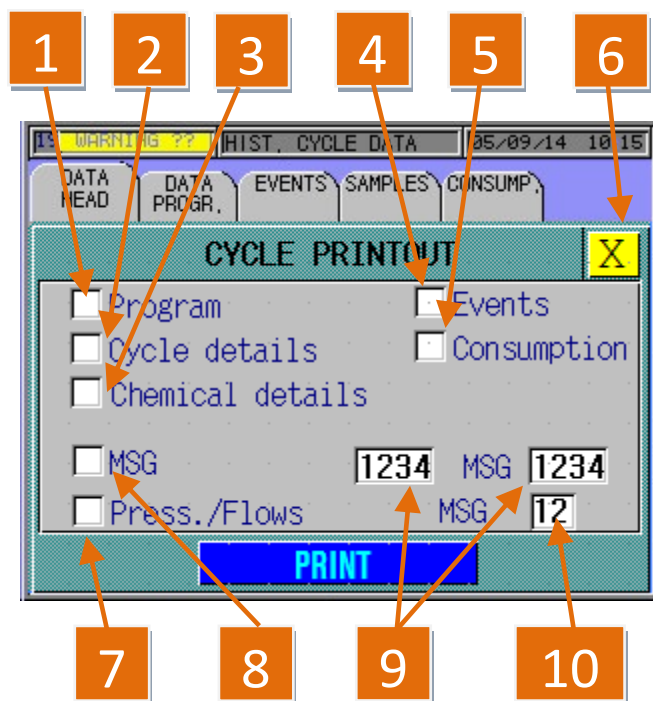

REFERENCE	DESCRIPTION
1	It prints a summary of the cycle phases and information about the instruments reprocessed, date, cycle type, etc.
2	It prints cycle detail plus consumption and times.
3	It prints the consumption of chemicals in detail.
4	It prints any alarms that may have occurred in the cycle and the reference phases.
5	It prints the consumption of water in the various phases of the
6	It resets printing and goes back to the screen page in figure 6.26.
7	It prints two lines for each point set on point 10, resuming pressure and flow of each channel (a reading every 4 seconds).
8	it lets you choose from which point stored to print the data gathered in the cycle (one every 4 seconds).
9	It displays the number of points stored in the cycle (one every 4 seconds); keeping within these values you can change them in order to select where you want printing to start. For instance, if you want to print just the central phases of the cycle, simply change number 1 with number 300 and number 834 with number 600 (when you touch the number a keypad appears on which you enter the value wanted).
10	See point 7.

Pic. 5.26

5.6 Parameter configuration

As far as concerns parameter configuration, proceed as explained below: press the “**SETUP**” key on the main screen page to gain access to the menu.

Enter the user code (Green password).

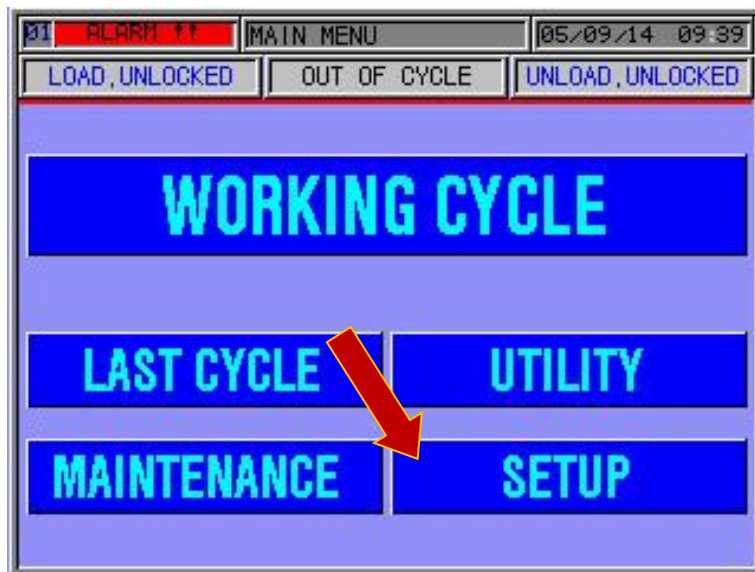

Pic. 5.28

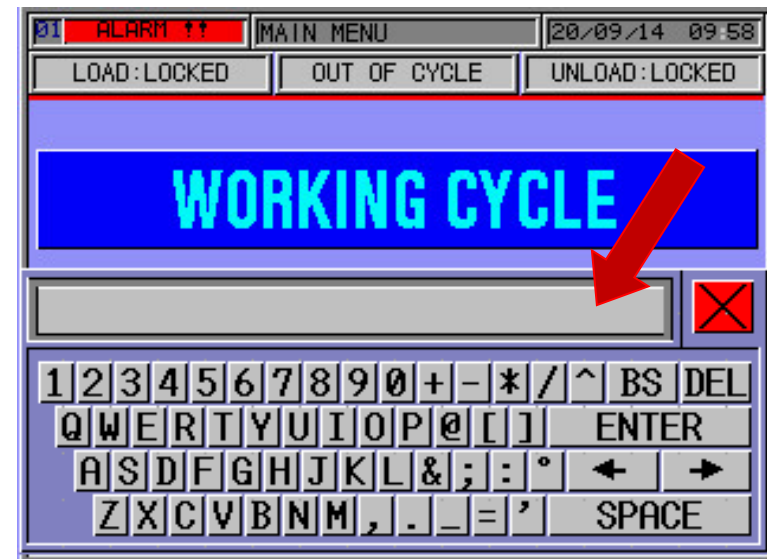

Pic. 5.29

5.7 User data configuration

You gain access to the user data from the configuration menu; to see them press the “USER DATA” key (pic. 5.30) you gain access to the screen page of figure 5.31.

NB. THE PARAMETERS DISPLAYED ON THE MACHINE ARE THE MANUFACTURER DEFAULT SETTINGS

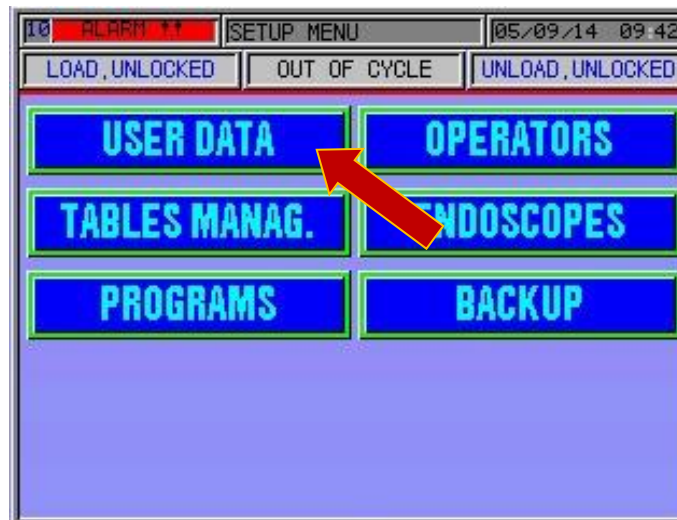

Pic. 5.30

As already mentioned, the EW2 system is programmed in the factory and some functions might not be active depending on the model. the following settings can be made on this screen page: **TO CHANGE THE PARAMETER, PRESS ON THE WORDING INSIDE THE WHITE WINDOW CORRESPONDING TO THE PARAMETER TO CHANGE.**

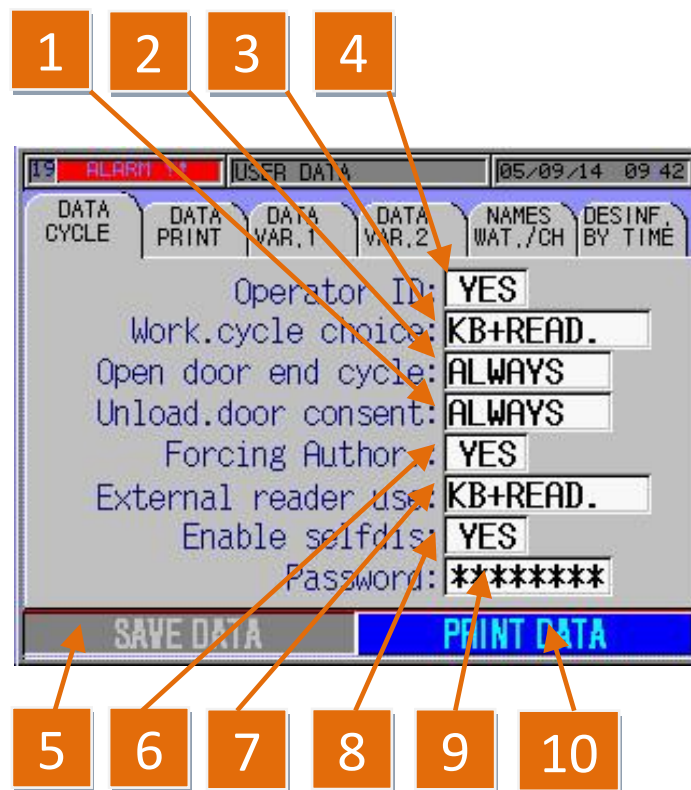

Pic. 5.31

REFERENCE	DESCRIPTION	
1	THIS PARAMETER MAKES IT POSSIBLE TO SET THE UNLOADING DOOR. THE POSSIBLE OPTIONS INCLUDE:	
	CYCLE OK	IT IS POSSIBLE TO OPEN THE DOOR ONLY WHEN THE CYCLE HAS BEEN CARRIED OUT CORRECTLY
	ALWAYS	IT IS POSSIBLE TO ALWAYS OPEN THE DOOR AT THE END OF THE CYCLE (IT IS NOT ADVISABLE TO CHOOSE THIS PARAMETER)
2	THIS PARAMETER MAKES IT POSSIBLE TO SET THE AUTOMATIC OPENING OF THE DOOR AT THE END OF THE CYCLE. THE POSSIBLE OPTIONS INCLUDE:	
	CYCLE OK	THE AUTOMATIC OPENING TAKES PLACE ONLY IF THE CYCLE HAS BEEN CARRIED OUT CORRECTLY
	ALWAYS	THE AUTOMATIC OPENING ALWAYS TAKES PLACE (IT IS NOT ADVISABLE TO CHOOSE THIS PARAMETER)
	NO	THE AUTOMATIC OPENING HAS NOT BEEN ACTIVATED
3	THIS OPTION MAKES IT POSSIBLE TO SET THE DATA ENTRY MODE (WE RECOMMEND KEEPING THE FACTORY DEFAULT SETTING). POSSIBLE OPTIONS INCLUDE:	
	INST.ID	THE DATA CAN ONLY BE ENTERED WITH THE BARCODE READER (WITH THE BARCODE READER INSTALLED)
	KEYBOARD	DATA CAN ONLY BE ENTERED MANUALLY VIA THE KEYBOARD
	MIXED	IT IS POSSIBLE TO ENTER DATA WITH BOTH THE KEYBOARD AND THE BARCODE READER
4	SET LIKE THIS THE SYSTEM PROMPTS THE OPERATOR ID BEFORE STARTING THE CYCLE; POSITIONING IT ON NO (SIMPLY TOUCH THE WORD YES TO CHANGE TO NO), THE CYCLE STARTS EVEN WITHOUT THE OPERATOR ID.	
5	IF PRESSED AFTER HAVING CHANGED A PARAMETER IT WILL SAVE THE NEW CONFIGURATION OTHERWISE THE PARAMETER WILL NOT BE CHANGED.	
6	SET LIKE THIS THE OPERATOR CAN SKIP THE CYCLE PHASES AND GO TO THE END OF THE CYCLE AFTER START-UP.	
7	THIS PARAMETER MAKES IT POSSIBLE TO ENABLE THE RFID OR THE BARCODE READER (WE RECOMMEND KEEPING THE FACTORY DEFAULT SETTING). POSSIBLE OPTIONS INCLUDE:	
	TASTE	THIS PARAMETER ENABLES DATA TO BE ENTERED ONLY BY USING THE KEYBOARD
	MIXED	THIS PARAMETER ENABLES DATA TO BE ENTERED BY USING BOTH THE KEYBOARD AND THE BARCODE/RFID READER
8	IN THIS WAY THE SELF-SANITISATION CYCLE CAN BE STARTED MANUALLY. IT WILL BE NECESSARY TO CHANGE “NO” TO “YES” EVERY TIME THAT YOU WANT TO START THE AUTOMATIC SELF-DISINFECTION OR PROGRAMMED DURING THE WEEK “DISINF. BY TIME” (POINT 11); TO ACTIVATE THE FUNCTION AT AN HOUR OR DAY DESIRED, ENTER THE “GREEN” OR “YELLOW” OPERATOR OR TECHNICIAN ID CODE ON THE “UTILITY” MASK ON THE MAIN MENU.	

9	POINT FOR CHANGING THE “ GREEN ” OPERATOR PASSWORD, KEYING THE NEW PASSWORD IN TWICE ON THE ALPHANUMERICAL KEYPAD THAT APPEARS. AFTER PRESSING ON THE ASTERISKS AND SAVING THE DATA (POINT 5) THE PASSWORD IS CHANGED.
10	BY PRESSING THIS KEY, YOU PRINT ALL THE USER DATA SET.

The following settings are possible from this screen page: to change a parameter press on the wording inside the white box that corresponds to the parameter to change and then press “save data” to store the changes made.
THE INFORMATION TO PRINT IS DEFINED ON THIS SCREEN PAGE.

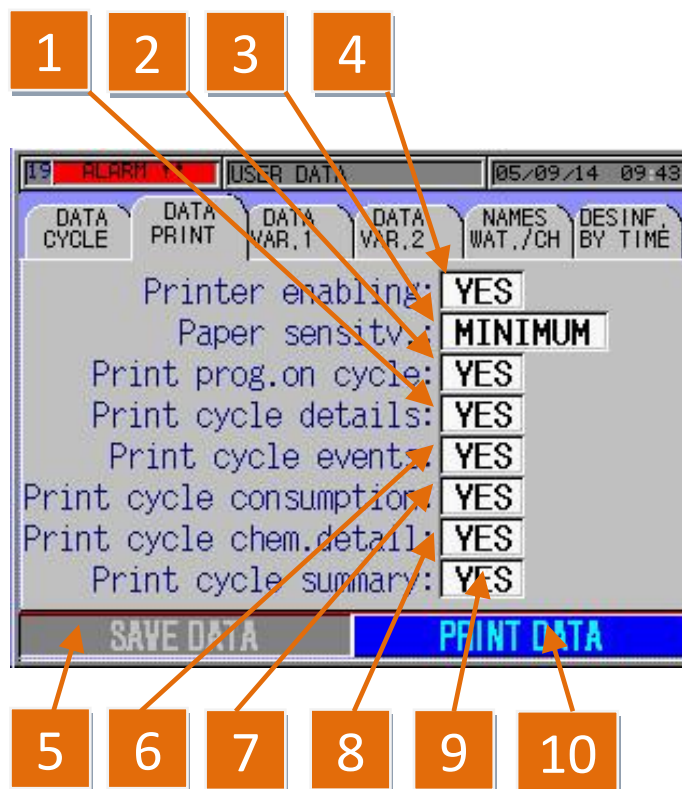

Pic. 5.32

REFERENCE	DESCRIPTION
1	IT PRINTS THE EVENTS OF THE CYCLE, THE ALARMS, WATER FILLING, LEAK TEST RESETTING, ETC.
2	IT ENABLES PROGRESSIVE PRINTING DURING THE CYCLE.
3	SPEED OF THE PAPER WHEN PRINTING; AS IT IS THERMAL PAPER, THE QUICKER THE PRINTING THE WORSE THE QUALITY.
4	IT ENABLES THE PRINTER INTEGRATED IN THE MACHINE.
5	IF PRESSED AFTER HAVING CHANGED A PARAMETER IT WILL SAVE THE NEW CONFIGURATION OTHERWISE THE PARAMETER WILL NOT BE CHANGED.
6	IT PRINTS THE EVENTS OF THE CYCLE.
7	IT PRINTS THE QUANTITY OF WATER AND CHEMICALS DIVIDED BY CYCLE PHASES.
8	IT PRINTS IN DETAIL THE VALUES OF THE CHEMICAL USED PER CYCLE DIVIDED BY SENSOR.
9	IT CREATES A SUMMARISED COPY OF THE CYCLE WHICH IS NORMALLY ATTACHED TO THE PATIENT'S MEDICAL RECORDS.
10	BY PRESSING THIS KEY, YOU PRINT ALL THE USER DATA SET.

The following settings are possible on this screen page: **to change a parameter press on the wording inside the white box that corresponds to the parameter to change and then press save data to store the changes made.**



Pic. 5.33

REFERENCE	DESCRIPTION	
1	THIS PARAMETER MAKES IT POSSIBLE TO SET THE MACHINE BEHAVIOUR IN CASE IT IS NECESSARY TO MANUALLY FORCE A STAGE OF THE PROCESS OR WHEN AN ALARM HAS BEEN TRIGGERED DURING THE CYCLE. POSSIBLE OPTIONS INCLUDE:	
	END CYCLE	THE MACHINE SKIPS A STAGE AT THE END OF THE CYCLE BY CARRYING OUT A RINSING STAGE WITH ONLY WATER IN ORDER TO REMOVE THE CHEMICAL SUBSTANCES FROM BOTH THE CHAMBER AND THE INSTRUMENT
	CONTINUE	THE MACHINE WILL SKIP THE STAGE IN PROGRESS IN ORDER TO PASS ONTO THE FOLLOWING ONE, OR IN THE EVENT OF AN ALARM RESET, IT WILL CONTINUE THIS STAGE (IT IS NOT ADVISABLE TO CHOOSE THIS PARAMETER)
2	THIS PARAMETER MAKES IT POSSIBLE TO SET THE MACHINE BEHAVIOUR IN CASE A POWER FAILURE OCCURS DURING THE CYCLE. POSSIBLE OPTIONS INCLUDE:	
	END CYCLE	THE MACHINE SKIPS A STAGE AT THE END OF THE CYCLE BY CARRYING OUT A RINSING STAGE WITH ONLY WATER IN ORDER TO REMOVE THE CHEMICAL SUBSTANCES FROM BOTH THE CHAMBER AND THE INSTRUMENT
	CONTINUE	THE MACHINE WILL CONTINUE TO CARRY OUT THE CYCLE FROM WHERE IT WAS INTERRUPTED (IT IS NOT ADVISABLE TO CHOOSE THIS PARAMETER)
3	IF POSITIONED ON “ YES ” THE SYSTEM PROMPTS THE OPERATOR CODE TO RESET THE ALARM, OPEN THE DOOR OR ABORT THE CYCLE.	
4	IF POSITIONED ON “ YES ” IT IS POSSIBLE TO ENABLE THE ACOUSTIC SIGNAL DURING THE MACHINE FUNCTIONING (ALARM).	
5	THIS OPTION APPEARS ONLY IF THE BARCODE READER OR RFID ARE ACTIVATED; IT IS THE OPERATOR’S ID PREFIX TO BE PUT EITHER ON THE BARCODE OR TAG.	
6	THIS OPTION APPEARS ONLY IF THE BARCODE READER OR RFID ARE ACTIVATED; IT IS THE INSTRUMENTS’ ID PREFIX TO BE PUT EITHER ON THE BARCODE OR TAG.	
7	NOT ACTIVATED	
8	ALL DATA ARE PRINTED BY PRESSING THIS KEY.	
9	IF PRESSED AFTER HAVING CHANGED A PARAMETER IT WILL SAVE THE NEW CONFIGURATION OTHERWISE THE PARAMETER WILL NOT BE CHANGED.	

The following settings are possible on this screen page: **to change a parameter press on the wording inside the white box that corresponds to the parameter to change and then press save data to store the changes made.**

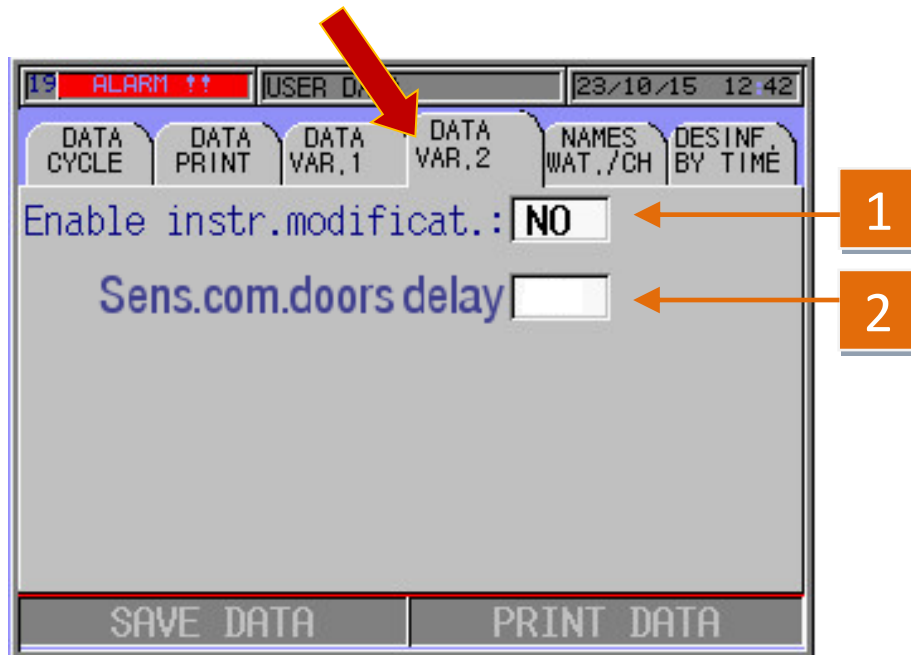

REFERENCE	DESCRIPTION
1	With the parameter setting on “NO” it is not possible to modify the parameters of saved endoscopes and memorize the datas present on machine memory.
2	Door opening sensor.

Pic. 5.34

The following settings are possible on this screen page: **to change a parameter press on the wording inside the white box that corresponds to the parameter to change and then press save data to store the changes made.**

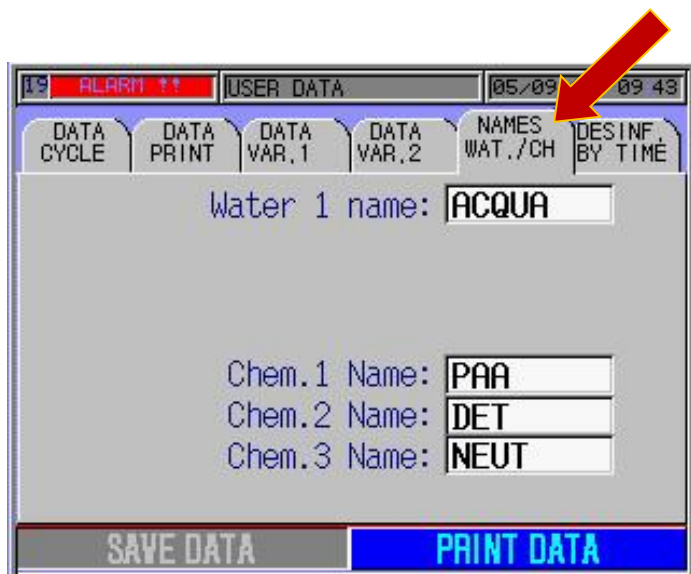

The names of the chemicals and waters used in the machine can be changed on this screen page:

	CHEMICAL 1	CAP	CHEMICAL 2	CAP	CHEMICAL 3	CAP
PERACETIC ACID	Neodisher Septo PAC	yellow	Neodisher SC	blue	Neodisher MEDIKLAR (opt.)	black
GLUTARALDEHYDE	Neodisher Septo GDA	yellow	Neodisher SC	blue	Neodisher MEDIKLAR (opt.)	black
HYDROGEN PEROXIDE	SteelcoXide-B	yellow	SteelcoXide-DT	blue	SteelcoXide-A	red

Pic. 5.35

5.8 Thermaldisinfection cycle

The following settings are possible on this screen page: **to change a parameter press on the wording inside the white box that corresponds to the parameter to change and then press save data to store the changes made.**

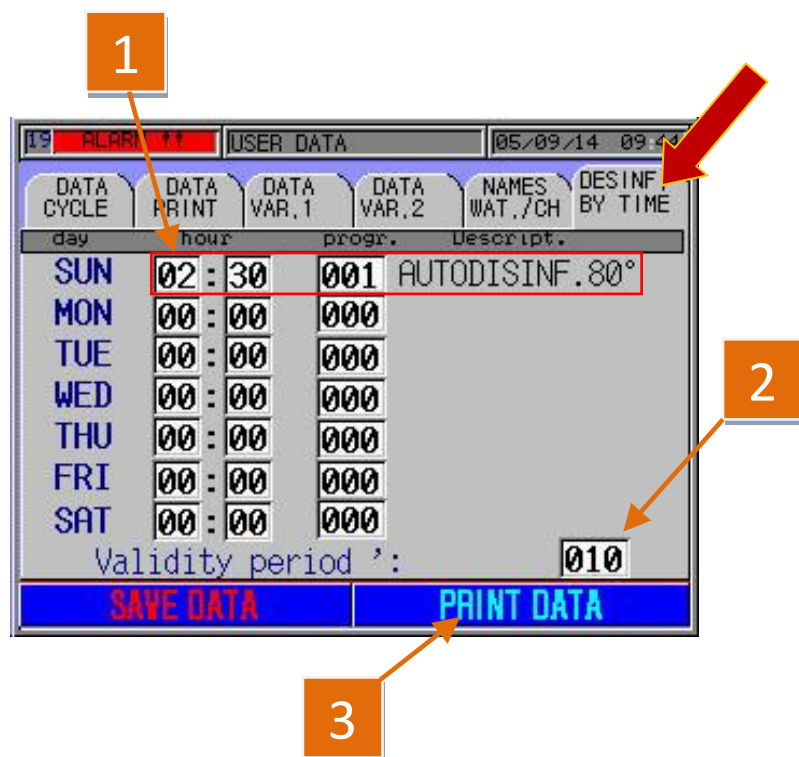

Granted that it is possible to carry out a self-disinfection cycle also manually, the parameters for automatic cycles can be set on this screen page.

REFERENCE	DESCRIPTION
1	Example of setting the time and day of the week to automatically start the self-disinfection cycle. in this example, if the start-up conditions have been met (doors closed, leak test closed and basket introduced). the automatic disinfection cycle will start at 2.30 in the morning.
2	Number 10 given in the example indicates the minutes the machine waits after the time set. in effect if, by chance, there is a blackout or an interruption in the water supply, etc.. The machine will wait, besides the time set, the minutes given in the box in point 3.
3	All data are printed by pressing this key.

Pic. 5.36

CAUTION!

BEFORE CARRYING OUT THE SELF-DISINFECTION CYCLE, EITHER MANUALLY OR SET TO START AUTOMATICALLY, CLOSE THE LEAK TESTS WITH THE CAPS SUPPLIED AND REMOVE ALL THE INSTRUMENTS AND ACCESSORIES FROM THE CHAMBER.

5.9 Self-disinfection procedure with a 12% sodium hypochlorite solution

According to ISO 15883-4, a self-disinfection cycle shall be provided to ensure that the endoscope washer does not become a focus for contamination of the load, and also to provide a means for disinfecting it after interventions for maintenance, repair or testing. Thermal disinfection using moist heat is the preferred method.

The Endoscope washer-disinfector must perform a daily thermal self-disinfection (regardless the chemical products used).

It is recommended to run the thermal self-disinfection program daily, to minimize contamination risk. This cycle can be performed automatically at a defined time: in case the endoscope washer-disinfector is not used during the weekend, make sure that the automatic self-disinfection is conducted.

- In case of machine stop between 24 and 72 hours it is necessary to carry out a device self-disinfection before its use;
 - In case of machine stop between 72 and 120 hours it is necessary to follow the dedicated procedure indicated here below:
 - Carry out 3 thermal self-disinfections
 - Verify the chemicals shelf life and replace them in case they are expired
 - In case the machine stop continues over 120 hours, please contact Steelco technical assistance for further details.
-

5.10 Instructions in case of extended machine stop

It is recommended to perform a self-disinfection cycle every day.

If the machine does not run for more than 24 hours, it is suggested to perform a self-disinfection cycle before using the machine.

5.11 Table management

Access is gained to table management from the setup menu. to see them press the “**TABLES MANAG.**” key (pic.5.37); you will access the screen page of picture 5.38.



Pic. 5.37

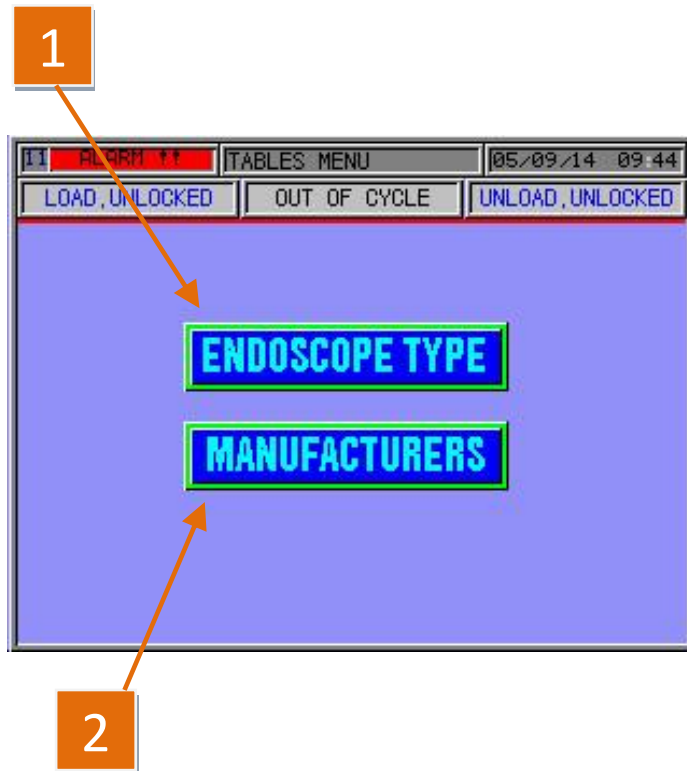

REFERENCE	DESCRIPTION
1	By pressing the “ ENDOSCOPE TYPE ” key you gain access to the screen page for entering the models of the various endoscopic instruments (e.g. gastroscopes, bronchoscopes, etc.), pic. 5.39.
2	By pressing the “ MANUFACTURERS ” key you gain access to the screen page for entering the manufacturers’ names (Storz, Olympus, etc.), pic. 5.41.

Pic. 5.38

5.11.1 Endoscopy type table

The following settings are possible on this screen page: to change a parameter press on the wording inside the white box that corresponds to the parameter to change and then press save data to store the changes made.

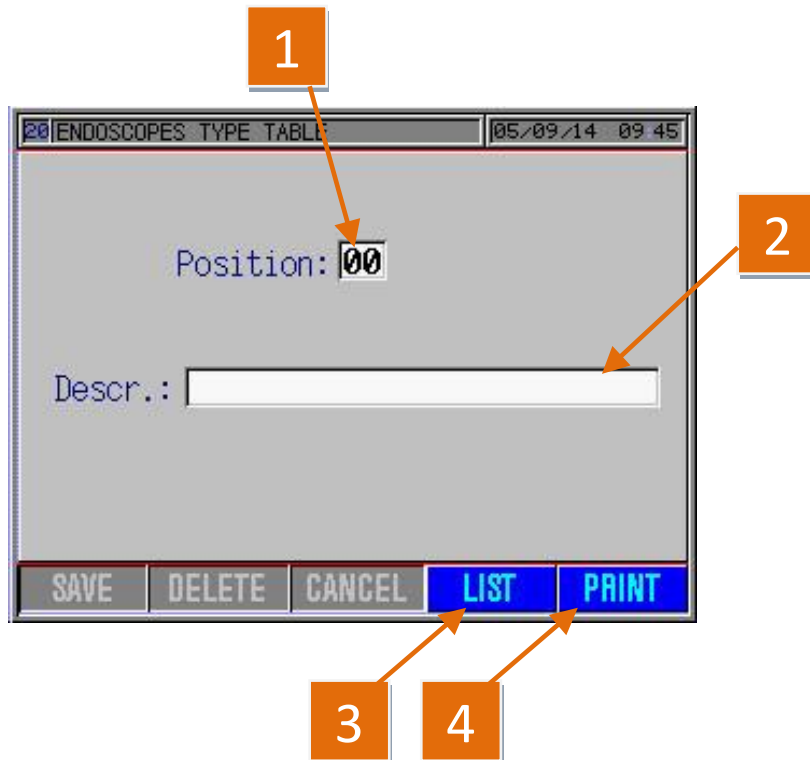

REFERENCE	DESCRIPTION
1	It gives the position (on the progressive list – see pic. 5.40) where the text added in point 2 will be stored.
2	Space reserved for entering the type of endoscope you wish to store (colonoscopy, bronchoscopy, etc.).
3	If pressed it displays the list of endoscope types entered (see pic.5.40).
4	If pressed it prints all the data of the endoscope table.

ALL WHAT IS STORED IN THIS TABLE WILL THEN BE USED AS ONE OF THE DETAILS FOR CREATING NEW ENDOSCOPIC INSTRUMENTS.

Pic. 5.39

All the types of endoscope entered and their positions can be seen on this screen page.

ENDOSCOPES TYPE TABLE		20/09/14 09:22
ENDOSCOPE TYPES LIST		✖
nr.	description	
0001	GASTROSCOPE	▲
0002	COLONSCOPE	
0003	DUODENOSCOPE	
0004	ECOENDOSCOPE	
0005	BRONCSCOPE	
0006		
0007		
0008		▼

To change the parameter, press twice on the writing inside the “**DESCRIPTION**” window corresponding to the parameter to change. you return automatically to pic. 5.39.

Pic. 5.40

5.11.2 Manufacturers table

The following settings are possible on this screen page: **to change a parameter press on the wording inside the white box that corresponds to the parameter to change and then press save data to store the changes made.**

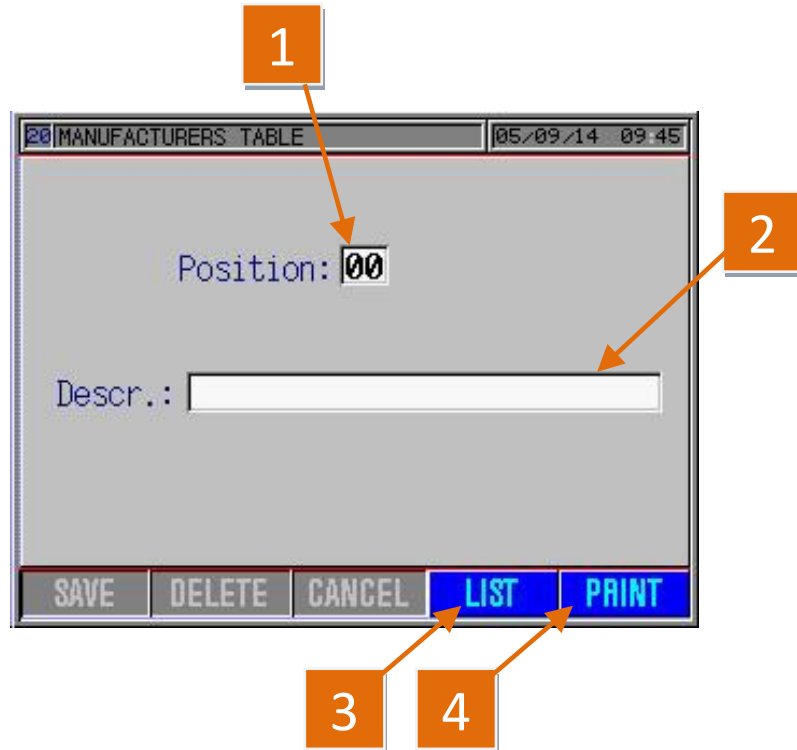

REFERENCE	DESCRIPTION
1	It gives the position (on the progressive list – see pic.5.42) where the text added in point 2 will be stored.
2	Space reserved for entering the name of the manufacturer you wish to store (olympus, pentax etc.).
3	If pressed it displays the list of manufacturers entered.
4	If pressed it prints all the data of the manufacturers table.

ALL WHAT IS STORED IN THIS TABLE WILL THEN BE USED AS ONE OF THE DETAILS FOR CREATING NEW ENDOSCOPIC INSTRUMENTS.

Pic. 5.41

The names of the endoscope manufacturers entered, and their positions can be seen on this screen page.

MANUFACTURERS TABLE		20/09/14 09:22
MANUFACTURERS LIST		✖
nr.	description	
0001	FUJINON	▲
0002	OLYMPUS	
0003	STORZ	
0004	PENTAX	
0005	HACHITA	
0006		
0007		
0008		▼

To change the parameter, press twice on the writing inside the “DESCRIPTION” window corresponding to the parameter to change. you return automatically to pic. 5.41.

Pic. 5.42

5.12 Operator setup

To enter the names of the operators who will be interacting with the unit, press the “**OPERATORS**” key of pic. 5.43 still on the “**SETUP**” menu and a screen page like the one in pic. 5.44 will appear.



Pic. 5.43

The following settings are possible on this screen page: **to change a parameter press on the wording inside the white box that corresponds to the parameter to change and then press save data to store the changes made.**

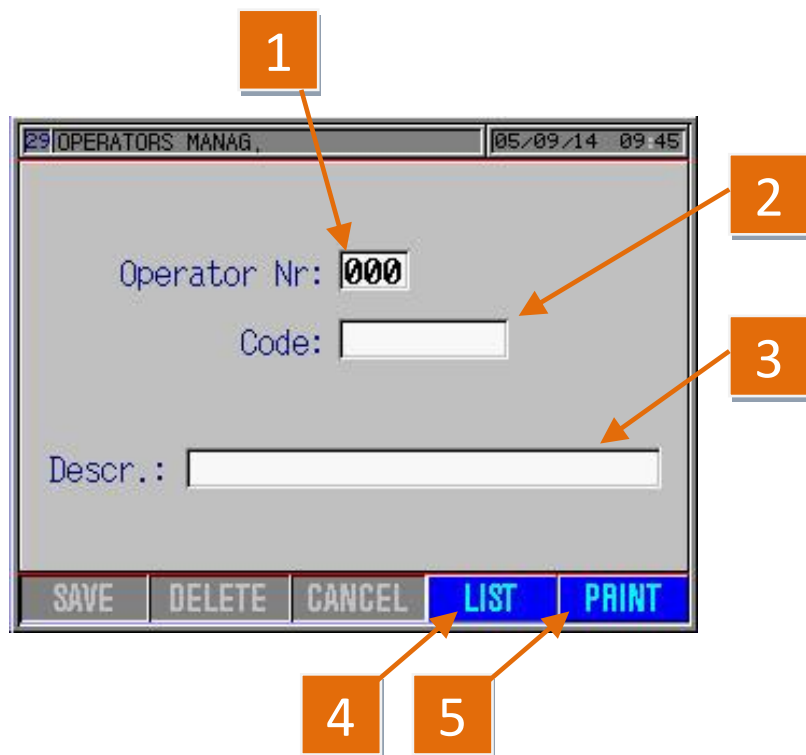

REFERENCE	DESCRIPTION
1	It gives the position (on the progressive list – see pic.5.45) where the text added in point 3 will be stored. Max 300.
2	It indicates where the operator access code has to be entered.
3	Space reserved for entering the name and last name of the operator you wish to store.
4	If pressed it displays the list of operators entered.
5	If pressed it prints all the names of the operators.

ALL WHAT HAS BEEN STORED IN THIS TABLE WILL THEN BE USED FOR RECOGNITION WHEN THE CYCLE IS STARTED.

Pic. 5.44

The list of operators with their access codes and positions can be displayed on this screen page.

pos. code		description
001	01	NAME OPERATOR 1
002		
003		
004		
005		
006		
007		
008		

To change the parameter, press twice on the writing inside the “DESCRIPTION” window corresponding to the parameter to change. you return automatically to pic. 5.44.

Pic. 5.45

5.13 Endoscope setup

To enter the new endoscopes with their pressure and flow parameters which will interact with the unit, proceed as follows: press the “ENDOSCOPES” key on the “SETUP” menu of pic. 5.46 and a screen page like the one in pic. 5.47 will appear.



NB. THE PARAMETERS DISPLAYED ON THE MACHINE ARE THE MANUFACTURER DEFAULT SETTINGS.

Pic. 5.46

To insert a new endoscope, push the button “LIST” in pic. 5.47 and double click on an empty line (pic.5.48). the picture pic. 5.49 is displayed.

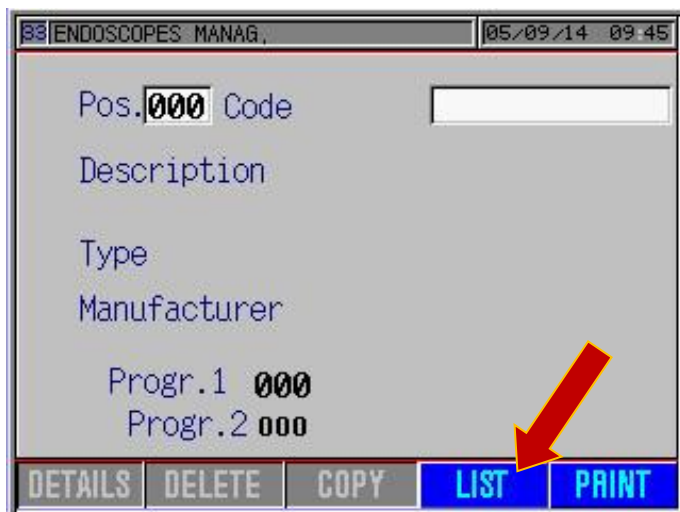

Pic. 5.47

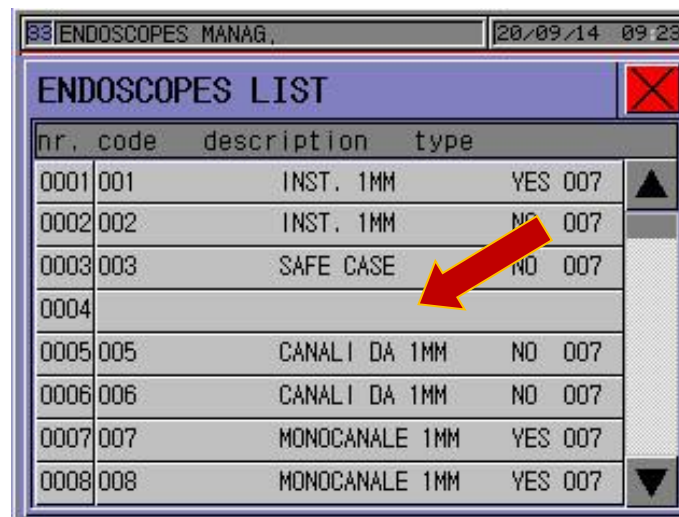

Pic. 5.48

5.13.1 Endoscope configuration parameter setting



Press “**DETAILS**” to start entering the information and parameters of the endoscope to add; an image like the one in pic. 5.49.1 will appear.

Pic. 5.49

From this screen page it is possible to set the working cycles of the instrument (point 1) and the type of instrument: single or multichannel, bronchoscope or similar, (point 2) or transesophageal probes (point 3). NB. It is necessary the special connector. The instruments can be maximum 500.

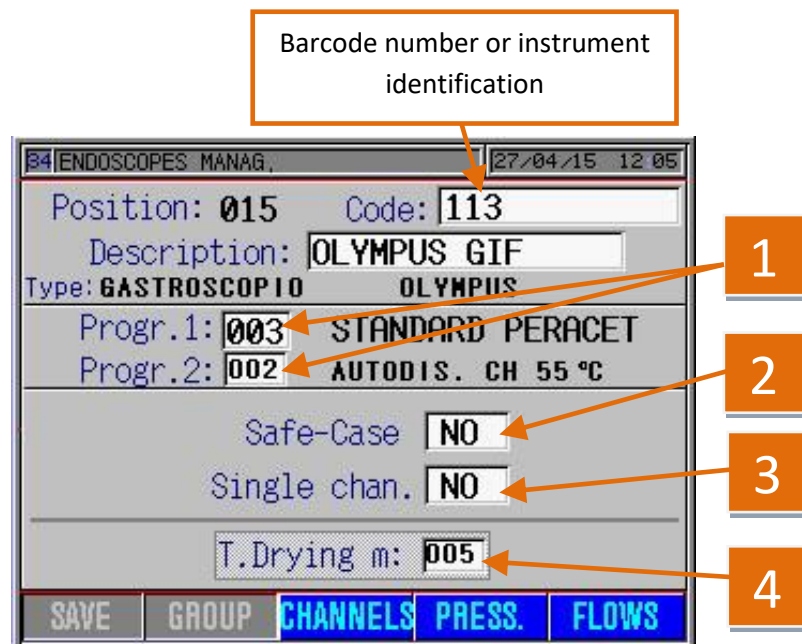

REFERENCE	DESCRIPTION
1	IN THE RED FIELD IT IS POSSIBLE TO SET THE MAIN PROGRAM (EX. COMPLETE CYCLE), WHEREAS IN THE BLACK FIELD FOR PROGRAM 2 YOU CAN SET THE SECONDARY CYCLE (EX. HIGH LEVEL DISINFECTION WITHOUT WASHING) OR NO CYCLE IS SET.
2	SET TO YES TO ACTIVATE TOE BOX.
3	ENDOSCOPE TYPE SETTING: IF THE ENDOSCOPE IS A SINGLE-CHANNEL INSTRUMENT, THE PARAMETER IS SET TO YES; IF THE ENDOSCOPE IS A MULTI-CHANNEL INSTRUMENT THEN THE PARAMETER IS SET TO NO.
4	SET THE DRYING TIME OF INSTRUMENT FOR DRYER CABINET IN CASE THE ARES SOFTWARE IS ACTIVATED (IN MINUTES).

Pic. 5.49.1

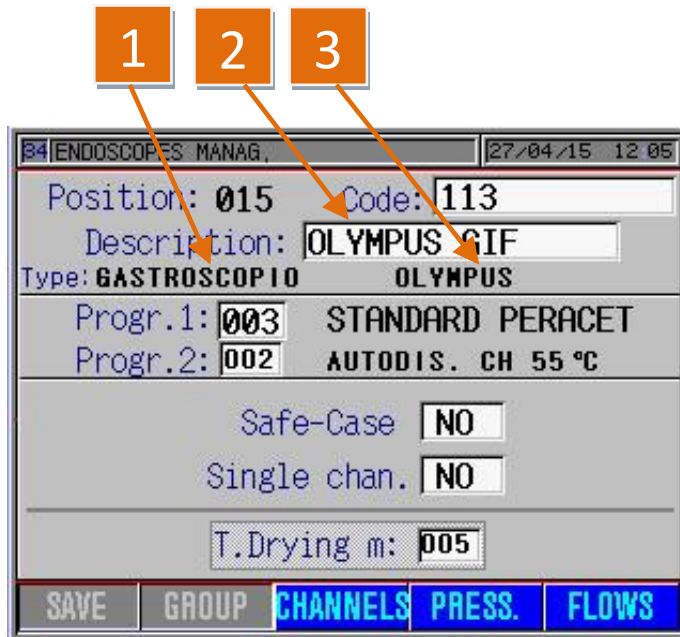

REFERENCE	DESCRIPTION
1	PRESS ON THE QUESTION MARKS AND A SCREEN PAGE APPEARS WHERE YOU CAN SELECT THE TYPE OF ENDOSCOPE TO ENTER (SEE PIC. 5.40). BY PRESSING TWICE ON THE TYPE OF ENDOSCOPE TO ENTER: THE NAME REPLACES THE QUESTION MARKS.
2	INSERT THE SERIAL NUMBER AND MODEL OF THE ENDOSCOPE ARE USUALLY ENTERED TO ENSURE CORRECT TRACEABILITY.
3	BY PRESSING ON THE QUESTION MARKS A SCREEN PAGE APPEARS WHERE YOU CAN SELECT THE NAME OF THE ENDOSCOPE MANUFACTURER (SEE PIC. 5.42). PRESS TWICE ON THE NAME OF THE MANUFACTURER: THE NAME REPLACES THE QUESTION MARKS.

Pic. 5.49.2

INSERTING MULTICHANNEL ENDOSCOPES

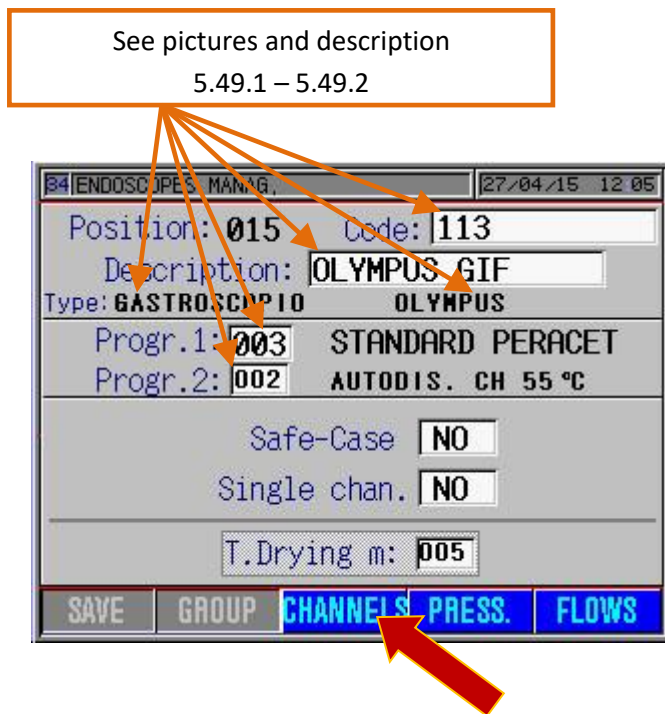

On this screen it is possible to set the multichannels instruments as gastroscopie, colonoscopia, ect., fibro and video.

Insert the request data.



Press **“SAVE”** button to save and press **“CHANNELS”** button to continue the programming. the system displays the screen as shown on pic. 5.50.

Pic. 5.49.3

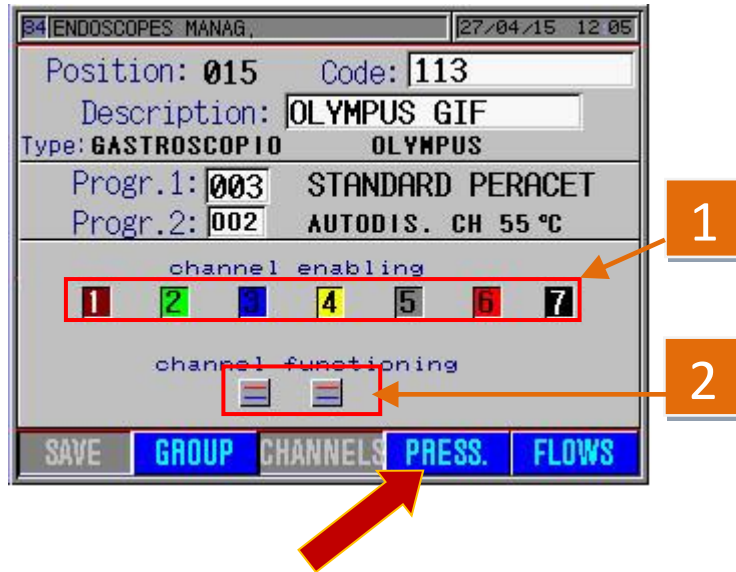
To change the parameter, press on the writing corresponding to the parameter to change.



Pic. 5.50

REFERENCE	DESCRIPTION
1	PRESSING ON THE NUMBER WILL EITHER ACTIVATE OR DEACTIVATE THE CHANNELS TO CONNECT TO THE ENDOSCOPE WITH THE FOLLOWING CHOICE CRITERIA: CHANNEL 1 - COLOUR BROWN – BIOPSY 1 CHANNEL 2 - COLOUR GREEN – BIOPSY 2 CHANNEL 3 - COLOUR BLUE - WATER CHANNEL 4 - COLOUR YELLOW - AIR CHANNEL 5 - COLOUR GREY - SUCTION CHANNEL 6 - COLOUR RED – AUXILIARY WATER CHANNEL 7 - COLOUR BLACK – CHANNELS < A 1MM (OPTIONAL)
2	BY PRESSING THE SYMBOL IT IS POSSIBLE TO SELECT THE TYPE OF PUMP FUNCTIONING. IN PARTICULAR, THE  SYMBOL REPRESENTS THE NON-STOP PUMP FUNCTIONING WHILE THE  SYMBOL REPRESENTS THE “ON-OFF” PUMP FUNCTIONING.

By pressing “PRESS.”button, the system displays the screen of pic.5.51 to insert the pressures parameters.

NB: The leak test is not displayed because it is automatic and always active.

STANDARD CHANNEL FLOW AND PRESSURE SETUP PARAMETERS:

THE STANDARD PARAMETERS ARE DISPLAYED BELOW WHICH ARE ABLE TO MEET THE SETUP REQUIREMENTS OF THE MAJORITY OF INSTRUMENTS CURRENTLY ON THE MARKET. THE INSTRUMENTS SUCH AS ENTEROSCOPES, PEDIATRIC GASTOSCOPES, PEDIATRIC COLONSCOPES OR ECOENDOSCOPES MUST BE ASSESSED INDIVIDUALLY.

	Min. Press.	Max. Press.	Min.F.	Max.F.
Channel 1	---	---	200 i/''	1200 i/''
Channel 2	---	---	200 i/''	1200 i/''
Channel 3	1,49 bar	1,5 bar	100 i/''	1000 i/''
Channel 4	1,49 bar	1,5 bar	100 i/''	1000 i/''
Channel 5	---	---	200 i/''	1200 i/''
Channel 6	---	---	50 i/''	1000 i/''
Channel 7	---	---	50 i/''	1000 i/''

Tab.5.10

PRESS "SAVE" TO CONFIRM WHAT HAS BEEN ENTERED.

STANDARD SETTING EXAMPLE FOR PRESSURES (SIMULATION OF A COLONSCOPE VIDEO) ACCORDING TO WHAT IS EXPRESSED IN TABLE.5.10.
 BY PRESSING “**FLAWS**” BUTTON, THE SYSTEM DISPLAYS THE SCREEN OF PIC.5.51 TO INSERT THE FLOWS PARAMETERS.



Pic. 5.51

STANDARD SETTING EXAMPLE FOR FLOWS (SIMULATION OF A COLONOSCOPE VIDEO) ACCORDING TO WHAT IS EXPRESSED IN TABLE.5.10.
 PRESS “**SAVE**” TO CONFIRM WHAT HAS BEEN ENTERED.
 TO INSERT A NEW INSTRUMENT, REPEAT THE PROCEDURE FROM PIC.5.47 TO PIC.5.52.

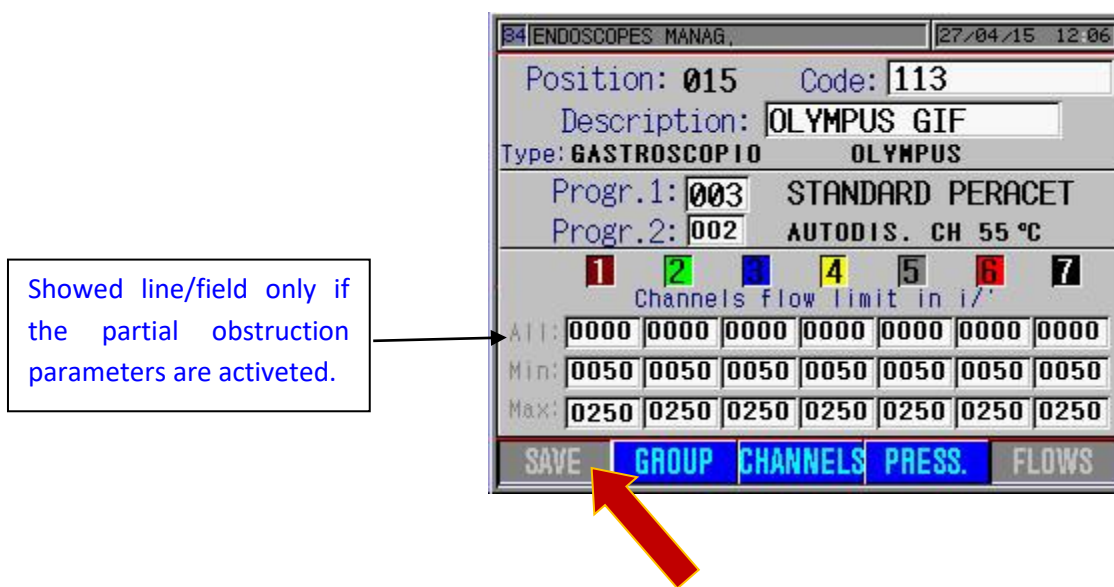

Pic. 5.52

5.14 Creating a backup of the settings

To create a Backup of the machine settings, to be recalled in the case of need, proceed as described below:
 press the “**BACKUP**” key of Pic. 5.54 on the “**SETUP**” menu, a screen page like the one in Pic. 5.55 will appear.

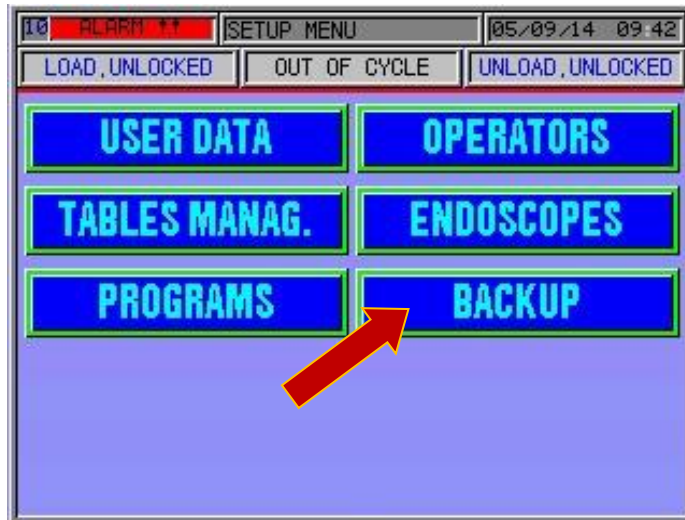

Pic. 5.54

Press the highlighted “**BACKUP**” key, confirm your choice and wait a few seconds. all the data stored will be filed automatically and available for recalling.

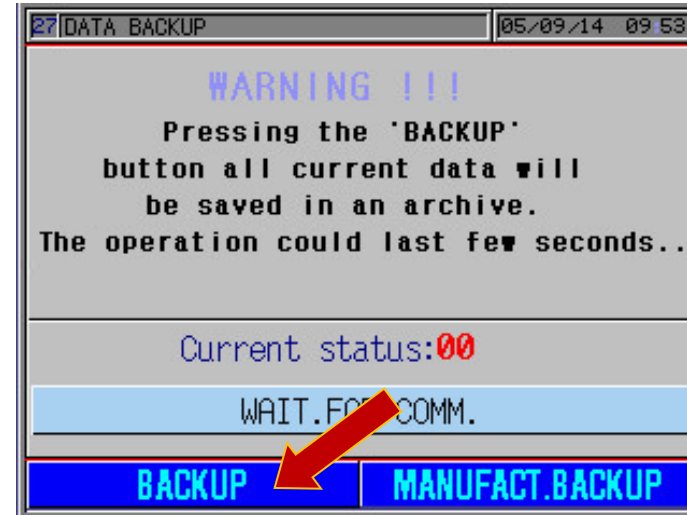

Pic. 5.55

DO NOT USE THE “MANUFACT.BACKUP” KEY BECAUSE ALL THE “STANDARD” FACTORY DATA WILL BE OVERWRITTEN BY THE NEW ONES AND LOST AS A RESULT.

5.15 Utility

The system is provided with a Utility Menu where it is possible to visualize the machine status, to enable manually the self-disinfection and, eventually, change the language. To access to the menu, proceed as follows:

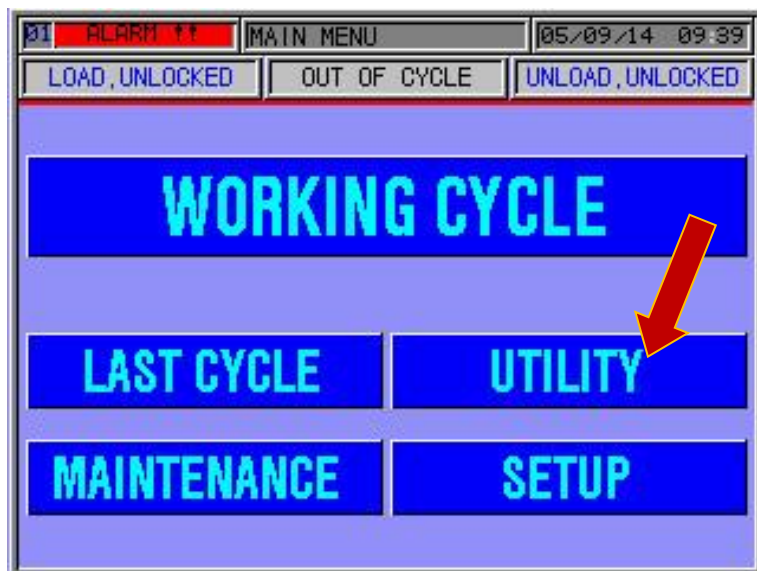

Press the “UTILITY” button will appear the screen as on pic. 5.57.

Pic. 5.56

From this screen page it is possible to change the following parameters:

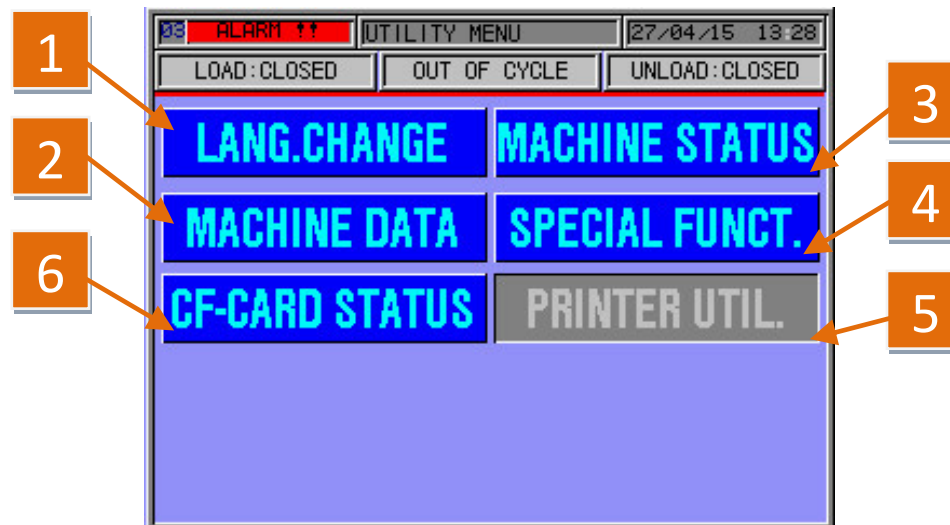

Pic. 5.57

REFERENCE	DESCRIPTION
1	BY PRESSING ON “ SELECT LANGUAGE ” YOU HAVE ACCESS TO A SUB MENU (PIC.5.58) WHERE IT IS POSSIBLE TO CHANGE THE MACHINE LANGUAGE WITH THE RELEVANT KEY.
2	BY PRESSING ON “ MACHINE DATA ” YOU HAVE ACCESS TO THE MAIN INFORMATION OF THE SYSTEM, SEE PIC. 5.59 – 5.60 – 5.61.
3	BY PRESSING ON “ MACHINE STATUS ” THE “FUNCTIONAL” SCREEN PAGES ARE DISPLAYED (ONLY VISUALIZATION) AS INDICATED IN THE PICTURES FROM PIC. 5.11 TO PIC.5.22.
4	DISABLED
5	DISABLED
6	BY PRESSING THE KEY “ CF-CARD STATUS ” THE AMOUNT OF MEMORY AVAILABLE ON THE REPLACEABLE CF-CARD IS DISPLAYED TOGETHER WITH INFORMATION ON THE CORRECT FUNCTIONING OF THE CARD.

From this screen it is possible to modify the language, pressing on the flag corresponding to the wanted one. pressing the “confirm” button, the modification will be saved, and on each screen all the phrases will be automatically changed on the selected language.



Pic. 5.58

Point 2 pic. 5.57



Pic. 5.59

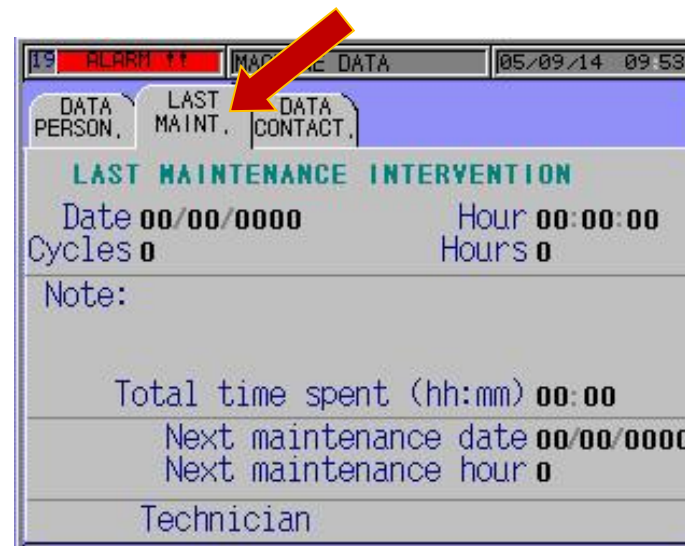

Pic. 5.60

Point 2 pic. 5.57

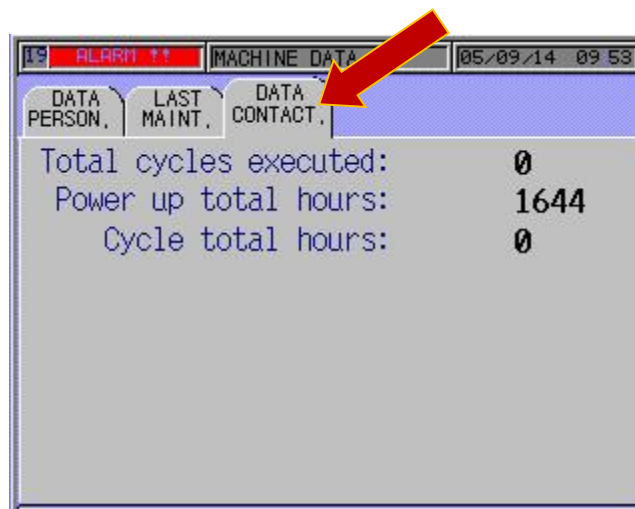

Pic. 5.61

Point 6 pic.5.57



DO NOT INSERT OPERATOR CODE, the system has already memorized the operator that have manually activated the self-disinfection funtion from the “UTILITY” menu.

ATTENTION: AS INDICATED, PAY ATTENTION THAT NO ONE INSTRUMENT HAVE TO BE INSIDE THE CHAMBER. IF THE CYCLE WILL START WITH ANY ENDOSCOPE INSTRUMENT OR THEIR ACCESSORIZE INSIDE, THESE ONES WILL BE FATALLY DAMAGED.

THE SYSTEM STARTS THE AUTOMATICALLY CYCLE AT DATE AND TIME SET.





Pic. 5.62



6. WASHING CYCLE

6.1 Preparation of the endoscopes

In order to be correctly reprocessed inside the EW 2 system, the endoscopes must undergo pre-cleaning and manual washing procedures. Follow the current applicable National Guideline instructions as well as any internal protocols in force.

Some of the main currently available Guidelines are specified below:

COUNTRY		GUIDELINES
	EUROPE	<i>ESGE±ESGENA guideline: Cleaning and disinfection in gastrointestinal endoscopy Update 2008.</i>
	ITALY	<i>ANOTE-ANIGEA - Linee guida Pulizia e disinfezione in endoscopia - Update 2011</i>
	FRANCE	<i>Guide de Bonne Pratique de désinfection des dispositifs médicaux - obligatoire depuis le 14 juin 1998. Conseil Supérieur d'Hygiène Publique de France, section prophylaxie des maladies transmissibles. Comité Technique Nationale des Infections Nosocomiales.</i>
	IRELAND	<i>PART 4: RECOMMENDED PRACTICES FOR ENDOSCOPY UNITS Health Service Executive Code of Practice for Decontamination of Reusable Invasive Medical Devices - Review date August 2008.</i>
	GERMANY	<i>Recommendation of the Commission for Hospital Hygiene and Infection Prevention at the Robert Koch Institute (RKI). Hygiene Requirements for Reprocessing Flexible Endoscopes and Additional Endoscopic Instrumentation - Published in the Federal Health Gazette in April 2002.</i>

	GREAT BRITAIN	<i>National Endoscopy Programme - Decontamination Standards for Flexible Endoscopes - Updated March 2009.</i>
	UNITED STATES	<i>SGNA Society of Gastroenterology Nurses and Associates, Inc. Standards of Infection Control in Reprocessing of Flexible Gastrointestinal Endoscopes - Revised in 2012.</i>

6.2 Check of endoscope instrument connectors

Connectors for the endoscope instruments supplied with the EW 2 machine must be checked daily by machine users and periodically by technicians in charge of maintenance.

The use of not original Steelco connectors or worn connectors can damage the endoscope instruments, activate machine alarms (ex. “channels disconnected”, “channel partially clogged” etc.) and most of all does not guarantee a correct disinfection process, endangering both patients’ and sanitary personnel’s wealth.

6.3 Start cycle

Once all the instruments settings have been carried out and all the machine operating parameters have been checked, by pressing the key “**WORKING CYCLE**” on the main screen page (Pic.5.91) it is possible to start a cycle. The screen page shown in Pic. 5.92 is displayed, where the parameter needed must be introduced.

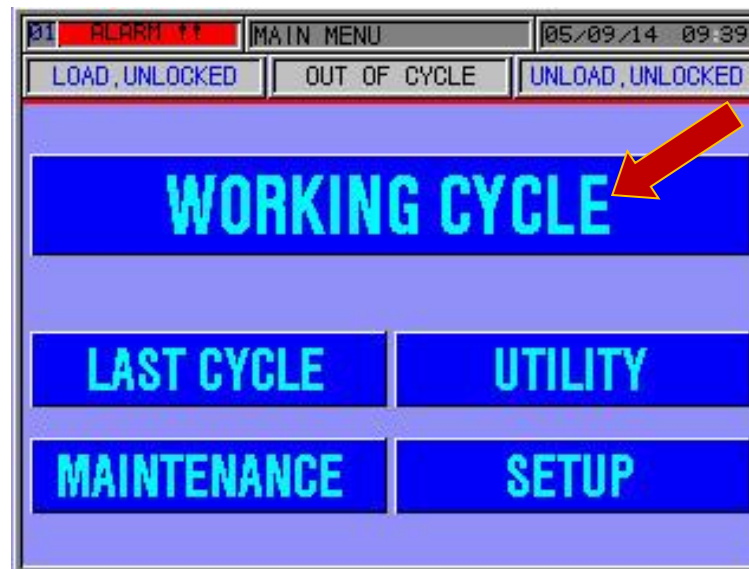

Pic. 5.91

START CYCLE FOR GASTROSCOPES, COLONSCOPES OR OTHERS
 From this screen page it is possible to change the following parameters:

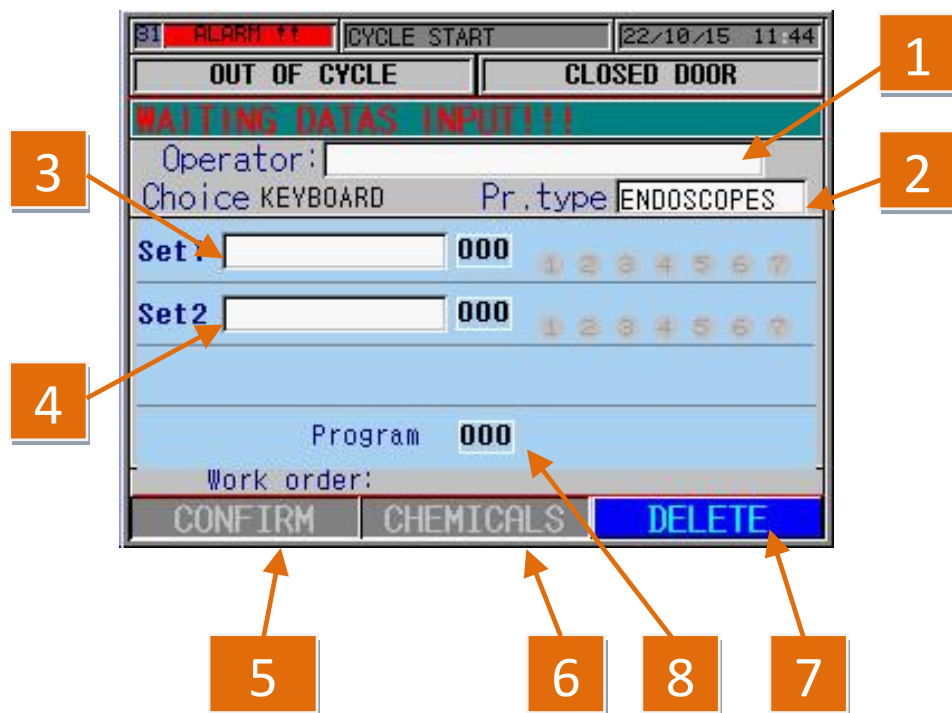

REFERENCE	DESCRIPTION
1	PRESS INSIDE THE FIELD AND INSERT THE ID-CODE. THE OPERATOR NAME WILL APPEAR.
2	BY PRESSING THIS FIELD, IT IS POSSIBLE TO SELECT THE TYPE OF PROGRAMME TO BE CARRIED OUT: MULTI-CHANNEL ENDOSCOPES (FIG. 5.92), SINGLE-CHANNEL ENDOSCOPES (FIG.5.93) OR THERMAL SELF-DISINFECTION (FIG. 5.94).
3	SELECTION OF ENDOSCOPE 3 TO BE REPROCESSED.
4	SELECTION OF ENDOSCOPE 2 TO BE REPROCESSED.
5	CONFIRM THE PARAMETER AND START THE WASHING
6	DISPLAY THE CHEMICAL STATUS.
7	CANCEL AND RESET THE PAREMETER.
8	THIS PARAMETER MAKES IT POSSIBLE TO SELECT THE SECOND PROGRAMME SET BY THE ENDOSCOPE PARAMETERS.

Pic 5.92

START CYCLE FOR BRONCHOSCOPES, CYSTOSCOPES OR OTHERS
 From this screen page it is possible to change the following parameters:

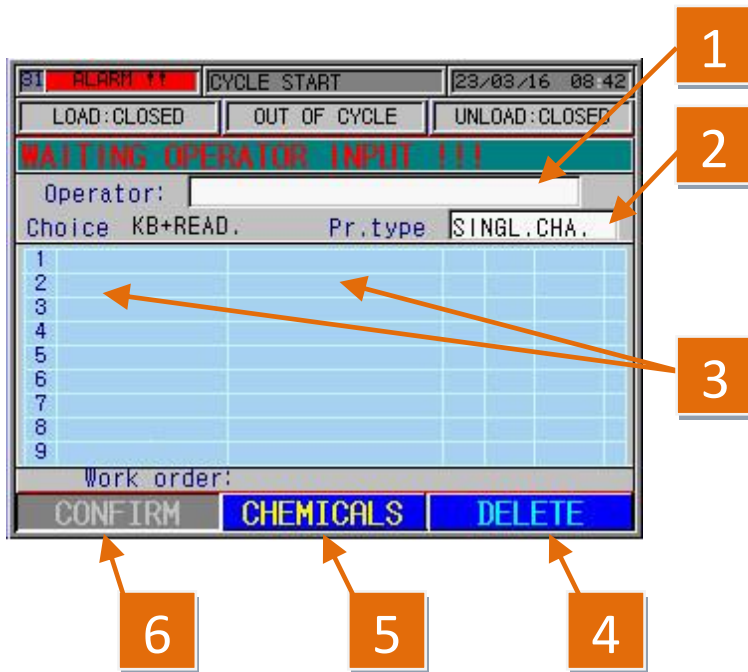

REFERENCE	DESCRIPTION
1	THIS PARAMETER CARRIES OUT THE SAME FUNCTION EXPLAINED PREVIOUSLY.
2	
3	BY PRESSING THIS FIELD, IT IS POSSIBLE TO INSERT THE SINGLE-CHANNEL ENDOSCOPE: THE FOLLOWING WINDOW WILL APPEAR (FIG. 5.94). ONCE THE ENDOSCOPE IN THIS FIELD HAS BEEN SELECTED, THE CODE AND NAME OF THE INSTRUMENT IS STATED.
4	THIS PARAMETER CARRIES OUT THE SAME FUNCTION EXPLAINED PREVIOUSLY.
5	
6	

FOLLOW THE SAME METHOD TO INSERT THE OTHER INSTRUMENTS IN THE TABLE TO COMPLETE THE POSITIONS AVAILABLE. THE MACHINE CAN ALSO BE LOADED WITH MIXED BATCHES "VIDEO" AND FIBROENDOSCOPES.

Pic. 5.93

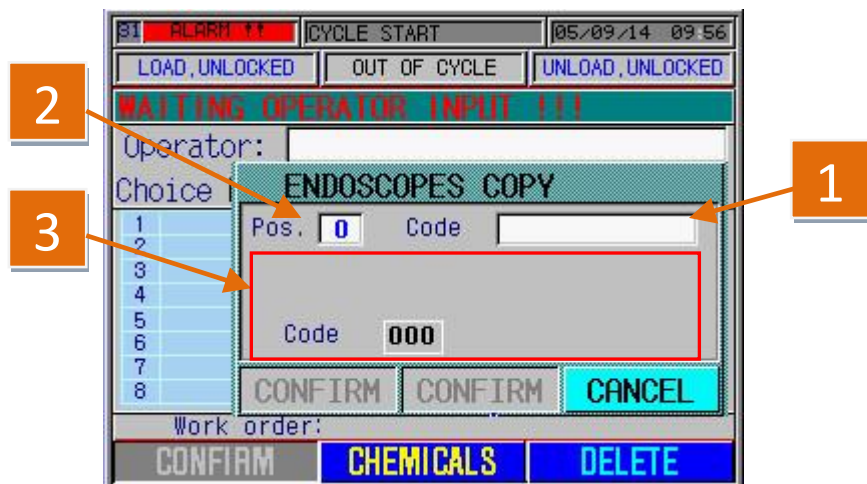

REFERENCE	DESCRIPTION
1	IN THIS FIELD, IT IS POSSIBLE TO ENTER THE ENDOSCOPE CODE.
2	IN THIS FIELD, IT IS POSSIBLE TO ENTER THE POSITION WHERE THE ENDOSCOPE IS TO BE INSERTED.
3	IN THIS SECTION, SOME DATA RELATING TO THE ENDOSCOPE THAT HAS JUST BEEN INSERTED IS STATED, SUCH AS: NAME, MANUFACTURER, TYPE OF PUMP OPERATION AND ASSOCIATED CYCLE.

Pic. 5.94

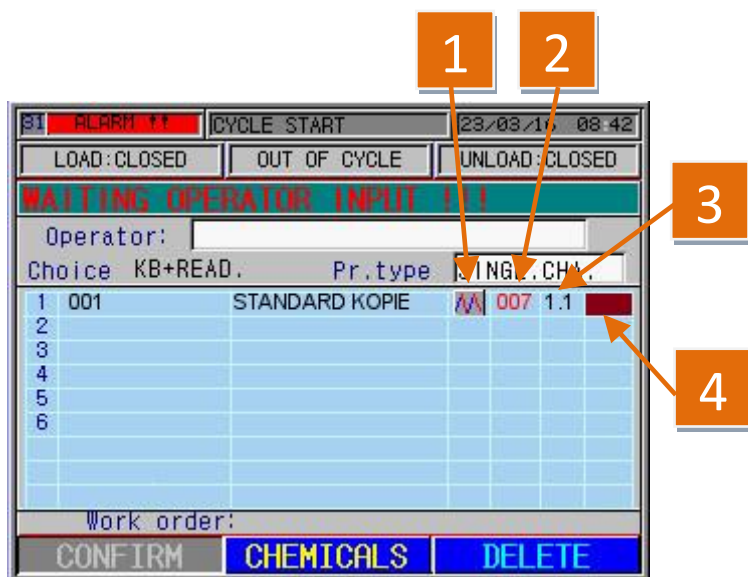

REFERENCE	DESCRIPTION
1	IN THIS FIELD, THE TYPE OF PUMP OPERATION IS DISPLAYED.
2	IN THIS FIELD, THE CODE OF THE PROGRAM ASSOCIATED WITH THE ENDSCOPE IS STATED.
3	THE FIRST NUMBER IS THE SET AND THE SECOND NUMER THE CHANNEL
4	THE COLOR OF THE CHANNEL

Pic. 5.95

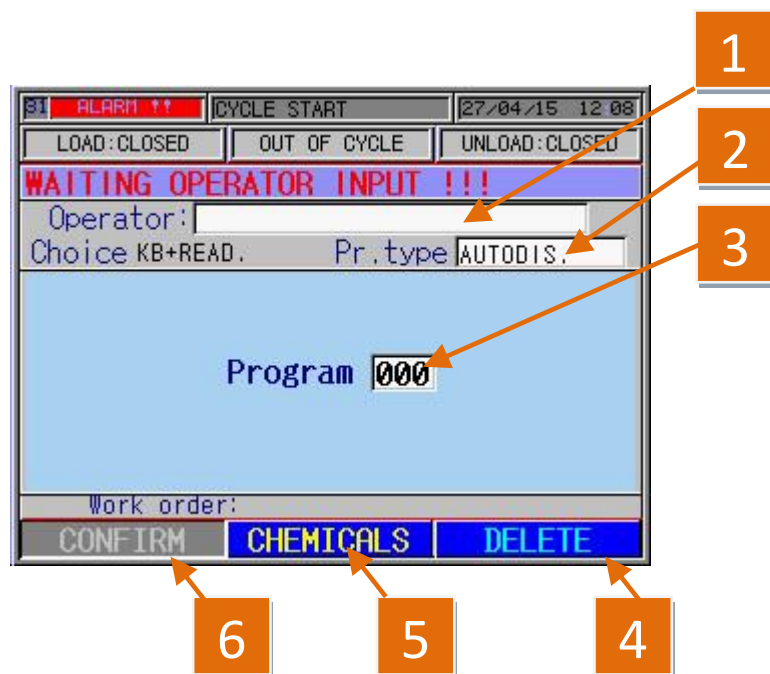

REFERENCE	DESCRIPTION
1	THIS PARAMETER CARRIES OUT THE SAME FUNCTION EXPLAINED PREVIOUSLY.
2	
3	IN THIS FIELD, IT IS POSSIBLE TO SELECT THE SELF-DISINFECTION CYCLE TO BE CARRIED OUT.
4	THIS PARAMETER CARRIES OUT THE SAME FUNCTION EXPLAINED PREVIOUSLY.
5	
6	

Pic. 5.96

7. PROGRAMMED MAINTENANCE

7.1 Operator maintenance

Components	ENDOSCOPES WASHER EW2							TIME	
	Programmed maintenance scheme								
	Step	months							Activity
make every.....	3	6	9	12	15	18	24		
Chamber filters	make every day							Take filters and clean.	10'
Leak test filter	make every.....		x					Replace.	1'
Chemical compartment	make every day							Check every day the cleaning of chemical compartment. In case of leakage call the service.	5'
Pre filter dryer F5 (optional)	make every 100 hours							Replace.	2'
Dryer HEPA filter (optional)	make every 300 hours							Replace.	1'
Water filters 0,45 micron	make every.....		x					Replace.	10'
Water filters 0,1 micron	make every.....		x					Replace.	10'
Channel filters 40 micron	make every.....		x					Replace.	10'
Temperature probes	make every.....				x			During periodic validation, check the sensor status.	5'
Safety thermostat	make every.....				x			Verify the sensor.	1'
Chemical/water flowmeter	make every.....		x					Check the impeller, the calibration and the presence of leakages.	30'

Chemical tank level sensor	make every.....		x						Check the functioning and visual control (calcium problems)	5'
Dosing pump connection pipe	make every.....		x						Check of any crashing, leakages or hardening.	2'
Washing arms or nozzles	every week								Check for free rotation. Open the cleaning caps and wash inside; check and in case clean the nozzles.	2'
Door gasket	make every...		x						Verify the gasket and replace after one year.	20'
Washing pumps	make every...				x				Check for water leakage from the arm seal and correct flow (50 to 60 impuls)	5'
Water heating element	make every...				x				Check for water leakage from the gasket and check ampere consumption (10 A per unit)	1'
Dryer heating elements (optional)	none								Operation is checked by the control system and check ampere consumption	5'
Macchine nozzles of basket connection	make every...		x						Check the status and replace the oring.	2'
Drain pump	make every...				x				Check for any leakage, if necessary, remove and clean the membrane seat.	1'
General test	make every...								Operation is checked by the control system. Check for any leakage and the electrical connections.	15'
Unloading water pipe	make every...				x				Check the situation of the pipe and the seal.	5'
Loading water pipes	make every...				x				Check the situation of the pipe and the seal.	5'
Teflon shim inside the chamber	every month								Check the correct position. Fix the screws.	10'

Compressed air	make every...		x						Check the calibration of compressed air for channels purging and pneumatic valves.	2'
Basket/instrument connection pipes	make every day								Check the status of the silicon pipe for the connection of basket/instrument. If necessary replace them.	1'
Machine leakage	make every...		x						Check the leakage during functioning.	5'
Check the security on the doors	make every		x						Control the correct work of the motors and switch	5'
Silicon pipe basket/instrument	make every...				x				Replace.	20'
Luer connectors male/female basket	make every...							x	Replace.	30'
Endoscope oring connectors	make every day								Check the status of the oring. If necessary replace them.	1'
Basket	make every		X						Check the status of screws and if necessary, fix it.	5'

8. MACHINE ALARMS

IN CASE OF ALARM, AFTER IT HAS BEEN CLEARED, THE MACHINE WILL CARRY OUT 2 FINAL RINSES AND DEPENDING ON THE RELATED PARAMETER IT CONTINUES THE CYCLE, RESTART IT OR ABORT IT.

8.1 Trouble shooting

In the following table are listed the alarms for the machine EW2, together with relevant possible causes and solutions. The explanations given below must not be considered exhaustive. Only the more frequent causes have been considered.

HAKKO ALARM MESSAGE	ALARM DESCRIPTION	POSSIBLE CAUSES	SOLUTION	OPER.	SUPERV.	MANUF.
00 MOTHERBOARD PROBLEMS			- seek technical assistance.			X
01 PLC FAILURES (XOB 10-12 VTEST)			- seek technical assistance.			X
02 FAILUER ON TRANSD. OF LT TANK	During the leak test the pressure sensor, which control the air expansion cylinder, doesn't read correctly the pressure value.	- pressure sensor failure. - PLC board failure (see electrical scheme).	- seek technical assistance.			X
03 WATER LEAK	The system detects the water leak under the machine during the functioning normally.	- sensor failure. - leak on hydraulic circuit.	- sensor replacement. - check hydraulic circuit.	X in part	X in part	X
04 FAILURE ON DRYING PROBE	During the external drying phase or during the normally functioning, the temperature sensor doesn't read correctly.	- sensor failure.	- replace the sensor. - seek technical assistance.		X	X

HAKKO ALARM MESSAGE	ALARM DESCRIPTION	POSSIBLE CAUSES	SOLUTION	OPER.	SUPERV.	MANUF.
05 PLC BLOCKED			- seek technical assistance			X
06 ENERGY LACK ON CYCLE	During the cycle the power supply has failed.	- machine circuit breaker intervention. - no power supply.	- open the machine electrical panel, reset the circuit breaker and the running cycle. - restore the power supply and reset the running cycle.			X
07 EMERGENCY STOP	During the cycle a failure on the auxiliary has occurred.	- machine auxiliary circuit breaker intervention, auxiliary on failure.	- open the machine electrical panel, reset the circuit breaker and the running cycle. Check that the auxiliary is working.			X
08 MAGNETOTHER M. INTERV.	During the cycle a failure on one of the electrical components has occurred.	- fault in one of the pumps or in a solenoid valve (earth leakage).	- check the pumps windings and possible earth leakages of the machine solenoid valves.			X
09 HEAT.EL. THERM.SAFETY	During heating, protection against the heating elements overheating has occurred.	- sensor failure. - lack of water in the chamber. - temperature probes failure. - heating elements relay failure.	- check and/or replace the heating elements protection sensor. - check and/or replace the chamber temperature probes. - check and/or replace the heating elements. - check for possible water leakages from the washing chamber.			X
10 CONNECTION LACK: AIR/WATER	The pressure of the incoming compressed air is below the expected 6 bar or the water pressure is below the expected 2 bar.	- failure of the pressure switch that controls the minimum compressed air pressure. - compressed air not available. - failure of the pressure switch that controls the minimum water pressure. - water not available.	- check and/or replace the control pressure switch. - check and restore the inlet compressed air. - check and/or replace the control pressure switch. - check and/or replace the control pressure switch.			X
11 TANK TOO FULL	The washing chamber has been filled with more than 16 liters of water	- water flow meter failures. - PLC failure.	- check the calibration and the functioning of the two water flow meters. - PLC check.			X

HAKKO ALARM MESSAGE	ALARM DESCRIPTION	POSSIBLE CAUSES	SOLUTION	OPER.	SUPERV.	MANUF.
12 LOADING DOORS FAILURE TIME	The loading door doesn't close.	<ul style="list-style-type: none"> - door motor failure. - door microswitch failure. - door chain 	<ul style="list-style-type: none"> - check and/or replace the door motor. - check and/or replace the door microswitch. - check and/or replace the door chain. 			X
13 UNLOADING TIME FAILURE	The unloading door doesn't close.	<ul style="list-style-type: none"> - door motor failure. - door microswitch failure. - door chain 	<ul style="list-style-type: none"> - check and/or replace the door motor. - check and/or replace the door microswitch. - check and/or replace the door chain. 			X
14 L. DOOR NOT CLOSED ON CYCLE	The loading door has opened during the cycle.	<ul style="list-style-type: none"> - door position microswitch failure. - door chain 	<ul style="list-style-type: none"> - check and/or replace the door microswitch. - check and/or replace the door chain. 			X
15 UNL. DOOR NOT CLOSED ON CYCLE	The unloading door has opened during the cycle.	<ul style="list-style-type: none"> - door position microswitch failure. - door chain 	<ul style="list-style-type: none"> - check and/or replace the door microswitch. - check and/or replace the door chain. 			X
16 NORMAL DRAIN FAILURES	There is still water in the washing chamber or a fault in the minimum level sensor during the draining phase.	<ul style="list-style-type: none"> - drain pump failure (if drain pump is fitted). - chamber minimum level sensor failure. - failure on the drain valve pilot valve. - pneumatic drain valve failure. 	<ul style="list-style-type: none"> - check the drain pump. - check for water in the washing chamber and eventually check the correct functioning of the drain valve and its pilot valve. 			X
17 SPECIAL DRAIN FAILURES	N.C.					
18 BLOWER FAILURES (PR. SWITCH)	During the external drying phase of instrument, the pressure switch (control) has indicated pressure lack on outside of blower.	<ul style="list-style-type: none"> - pressure switch failure. - blower failure. - blower filter obstructed. - problem on air circuit 	<ul style="list-style-type: none"> - check that the aspiration filters of blower are clean. - check blower motor. - check blower pressure switch. - check air circuit 		X	X

HAKKO ALARM MESSAGE	ALARM DESCRIPTION	POSSIBLE CAUSES	SOLUTION	OPER.	SUPERV.	MANUF.
19 TANK HEAT. FAILURES (TIME)	The set temperature has not been reached during the heating phase	<ul style="list-style-type: none"> - washing chamber heating elements faulty. - heating element remote control switch faulty. - PLC command fault (relay board). 	<ul style="list-style-type: none"> - check the washing chamber heating elements. - check the operation of the heating element remote control switch. - check the command board controlling the heating element remote control switch. 			X
20 DRYER HEAT. FAILURES (TIME)	The temperature did not increase 1°C in the set time during the external drying phase of instrument.	<ul style="list-style-type: none"> - dryer heating elements faulty. - missing permission to activate dryer heating element. - heating element remote control switch/relay faulty. 	<ul style="list-style-type: none"> - check the dryer heating elements. - check that the permissions to activate the dryer heating elements are OK. - check the command board controlling the heating element remote control switch. 		X	X
21 TANK HEAT. EMERGENCY	The water temperature has exceeded 60°C during the heating phase.	<ul style="list-style-type: none"> - PLC failure - heating element remote control switch/relay faulty. 	<ul style="list-style-type: none"> - check the command board controlling the heating element remote control switch. - check the command board controlling the heating element remote control switch. 			X
22 DRYER HEAT. EMERGENCY	The mechanic sensor has tripped to protect the maximum temperature of heating element during the external drying phase of instrument in the chamber.	<ul style="list-style-type: none"> - blower failure/not working. - mechanical sensor failure. - heating element remote control switch/relay faulty. 	<ul style="list-style-type: none"> - check the correct functioning of blower. - check the correct functioning of mechanical sensor placed on heating element. - check the command board controlling the heating element remote control switch. 		X	X
23 EXTREME WATER TEMP	The water temperature has exceeded the set temperature by 5°C during the heating phase.	<ul style="list-style-type: none"> - heating element remote control switch faulty. - PLC command fault (relay board) 	<ul style="list-style-type: none"> - check the command board controlling the heating element remote control switch. - check and/or replace the heating elements remote control switch. 			X

HAKKO ALARM MESSAGE	ALARM DESCRIPTION	POSSIBLE CAUSES	SOLUTION	OPER.	SUPERV.	MANUF.
24 WATER FILL. 1 CHAMBER (TIME)	The washing chamber has not been filled with the set quantity of water for the running phase.	<ul style="list-style-type: none"> - water inlet pneumatic valve fault. - water inlet valve pilot valve fault. - PLC command fault (relay board). - failure in flowmeters controlling the water when filling the washing chamber. - water filters clogged 	<ul style="list-style-type: none"> - check and/or replace the machine water input pneumatic valve. - check and/or replace the water input command valve pilot valve. - check and/or replace the water load command valve relay board or water load pump command. - check and/or replace the water load pump. - check and/or replace the water chamber quantity flow meters. - check and/or replace the machine water filters. 			X
25 WATER FILL. 2 CHAMBER (TIME)	The washing chamber has not been filled with the set quantity of water for the running phase.	<ul style="list-style-type: none"> - water inlet pneumatic valve fault. - water inlet valve pilot valve fault. - PLC command fault (relay board). - failure in flowmeters controlling the water when filling the washing chamber. - water filters clogged 	<ul style="list-style-type: none"> - check and/or replace the machine water input pneumatic valve. - check and/or replace the water input command valve pilot valve. - check and/or replace the water load command valve relay board or water load pump command. - check and/or replace the water load pump. - check and/or replace the water chamber quantity flow meters. - check and/or replace the machine water filters. 			X
26 TEMP.SENS. FAILURE (CONTROL)	Incorrect temperature reading in the washing chamber (control).	<ul style="list-style-type: none"> - PT1000 washing chamber faulty. - PLC reader card faulty. 	<ul style="list-style-type: none"> - check and/or replace the chamber temperature probe (control). - check and/or replace the temperature probe reader card. 			X
27 TEMP.SENS. FAILURE (RECORD)	Incorrect temperature reading in the washing chamber (recording).	<ul style="list-style-type: none"> - PT1000 washing chamber faulty. - PLC reader card faulty. 	<ul style="list-style-type: none"> - check and/or replace the chamber temperature probe (recording). - check and/or replace the temperature probe reader card. 			X

HAKKO ALARM MESSAGE	ALARM DESCRIPTION	POSSIBLE CAUSES	SOLUTION	OPER.	SUPERV.	MANUF.
28 LOADING TIME CHEM.1 EXCESSIVE	During the chemical loading phase, the time limit for reaching the set quantity parameter has been exceeded.	- fault or malfunction in chemical 1 load pump. - fault or malfunction in chemical 1 load control flow meters.	- clean and/or replace chemical 1 load pump. - clean and/or replace chemical 1 load control flow meters, then carry out the chemical calibration procedure.			X
29 LOADING TIME CHEM.2 EXCESSIVE	During the chemical loading phase, the time limit for reaching the set quantity parameter has been exceeded.	- fault or malfunction in chemical 2 load pump. - fault or malfunction in chemical 2 load control flow meters.	- clean and/or replace chemical 2 load pump. - clean and/or replace chemical 2 load control flow meters, then carry out the chemical calibration procedure.			X
30 LOADING TIME CHEM.3 EXCESSIVE	During the chemical loading phase, the time limit for reaching the set quantity parameter has been exceeded.	- fault or malfunction in chemical 3 load pump. - fault or malfunction in chemical 3 load control flow meters.	- clean and/or replace chemical 3 load pump. - clean and/or replace chemical 3 load control flow meters, then carry out the chemical calibration procedure.			X
31 LOADING TIME CHEM.4 EXCESSIVE	During the chemical loading phase, the time limit for reaching the set quantity parameter has been exceeded.	- fault or malfunction in chemical 4 load pump. - fault or malfunction in chemical 4 load control flow meters.	- clean and/or replace chemical 4 load pump. - clean and/or replace chemical 4 load control flow meters, then carry out the chemical calibration procedure.			X

HAKKO ALARM MESSAGE	ALARM DESCRIPTION	POSSIBLE CAUSES	SOLUTION	OPER.	SUPERV.	MANUF.
32 WASH.ARMS FLOW SENSOR BREACKDOWN	There is no flow in the washing chamber wash.arm circuit for more than 5 seconds.	<ul style="list-style-type: none"> - fault or malfunction in washing chamber impeller control flow meters. - recirculation pump faulty. - breakage in recirculation pump electric power supply remote control switch. - PLC control card faulty. 	<ul style="list-style-type: none"> - check and/or replace the washing chamber impeller control flow meters. - check recirculation pump operation or replace it in the event of faulty. - check and/or replace the recirculation pump electric power supply remote control switch command board. - check and/or replace the recirculation pump electric power supply remote control switch. 			X
33 CONTROL TANK CONNECTION LEAK TEST	During the first phase of cycle, the leak test pressure was below the set value.	<ul style="list-style-type: none"> - leak test pump broken. - set 1 disconnected. - set 2 disconnected. - set 3 disconnected. 	<ul style="list-style-type: none"> - check and/or replace the leak test pump. - check the set 1 connection. - check the set 2 connection. - check the set 3 connection. 			X
34 CONTROL CONNECTION SET 1	During the cycle the pressure on the collector was below the set value.	<ul style="list-style-type: none"> - failure of electronic sensor for pressure collector 1. - failure of mechanical sensor for pressure collector 1. - PLC card faulty. 	<ul style="list-style-type: none"> - check and/or replace the electronic sensor. - check and/or replace the mechanical sensor. - check and/or replace sensor control card/s and channel pump command. 		X	X

HAKKO ALARM MESSAGE	ALARM DESCRIPTION	POSSIBLE CAUSES	SOLUTION	OPER.	SUPERV.	MANUF.
35 CONTROL CONNECTION CHA.3 SET 1	During the cycle there was no minimum working pressure for channel 3 instrument 1.	<ul style="list-style-type: none"> - breakage in drum connection pipe (red). - disconnection in relative connector. - channel 3 instrument 1 pump faulty. - channel 3 instrument 1 pressure sensor faulty. - PLC card faulty. - pump broken 	<ul style="list-style-type: none"> - check pipe integrity and eventually replace it. - check if the connector is properly fastened to the instrument. - check and/or replace channel 3 instrument 1 pump. - check and/or replace channel 3 instrument 1 pressure sensor. - check and/or replace sensor control card/s and channel pump command. - check and/or replace the pump 	X in part	X in part	X
36 CONTROL CONNECTION CHA.4 SET 1	During the cycle there was no minimum working pressure for channel 4 instrument 1.	<ul style="list-style-type: none"> - breakage in drum connection pipe (black). - disconnection in relative connector. - channel 4 instrument 1 pump faulty. - channel 4 instrument 1 pressure sensor faulty. - PLC card faulty. - pump broken 	<ul style="list-style-type: none"> - check pipe integrity and eventually replace it. - check if the connector is properly fastened to the instrument. - check and/or replace channel 4 instrument 1 pump. - check and/or replace channel 4 instrument 1 pressure sensor. - check and/or replace sensor control card/s and channel pump command. - check and/or replace the pump 	X in part	X in part	X
37 CONTROL CONNECTION SET 2	During the cycle the pressure on the collector was below the set value.	<ul style="list-style-type: none"> - failure of electronic sensor for pressure collector 2. - failure of mechanical sensor for pressure collector 2. - PLC card faulty. 	<ul style="list-style-type: none"> - check and/or replace the electronic sensor. - check and/or replace the mechanical sensor. - check and/or replace sensor control card/s and channel pump command. 		X	X

HAKKO ALARM MESSAGE	ALARM DESCRIPTION	POSSIBLE CAUSES	SOLUTION	OPER.	SUPERV.	MANUF.
38 CONTROL CONNECTION CHA.3 SET 2	During the cycle there was no minimum working pressure for channel 3 instrument 2.	<ul style="list-style-type: none"> - breakage in drum connection pipe (red). - disconnection in relative connector. - channel 3 instrument 2 pump faulty. - channel 3 instrument 2 pressure sensor faulty. - PLC card faulty. - pump broken 	<ul style="list-style-type: none"> - check pipe integrity and eventually replace it. - check if the connector is properly fastened to the instrument. - check and/or replace channel 3 instrument 2 pump. - check and/or replace channel 3 instrument 2 pressure sensor. - check and/or replace sensor control card/s and channel pump command. - check and/or replace the pump 	X in part	X in part	X
39 CONTROL CONNECTION CHA.4 SET 2	During the cycle there was no minimum working pressure for channel 4 instrument 2.	<ul style="list-style-type: none"> - breakage in drum connection pipe (black). - disconnection in relative connector. - channel 4 instrument 2 pump faulty. - channel 4 instrument 2 pressure sensor faulty. - PLC card faulty. - pump broken 	<ul style="list-style-type: none"> - check pipe integrity and eventually replace it. - check if the connector is properly fastened to the instrument. - check and/or replace channel 4 instrument 2 pump. - check and/or replace channel 4 instrument 2 pressure sensor. - check and/or replace sensor control card/s and channel pump command. - check and/or replace the pump 	X in part	X in part	X
40 CONTROL CONNECTION SET 3	During the cycle the pressure on the collector was below the set value.	<ul style="list-style-type: none"> - failure of electronic sensor for pressure collector 3. - failure of mechanical sensor for pressure collector 3. - PLC card faulty. 	<ul style="list-style-type: none"> - check and/or replace the electronic sensor. - check and/or replace the mechanical sensor. - check and/or replace sensor control card/s and channel pump command. 		X	X

HAKKO ALARM MESSAGE	ALARM DESCRIPTION	POSSIBLE CAUSES	SOLUTION	OPER.	SUPERV.	MANUF.
41 CONTROL CONNECTION CHA.3 SET 3	During the cycle there was no minimum working pressure for channel 3 instrument 3.	<ul style="list-style-type: none"> - breakage in drum connection pipe (red). - disconnection in relative connector. - channel 3 instrument 3 pump faulty. - channel 3 instrument 3 pressure sensor faulty. - PLC card faulty. - pump broken 	<ul style="list-style-type: none"> - check pipe integrity and eventually replace it. - check if the connector is properly fastened to the instrument. - check and/or replace channel 3 instrument 3 pump. - check and/or replace channel 3 instrument 3 pressure sensor. - check and/or replace sensor control card/s and channel pump command. - check and/or replace the pump 	X in part	X in part	X
42 CONTROL CONNECTION CHA.4 SET 3	During the cycle there was no minimum working pressure for channel 4 instrument 3.	<ul style="list-style-type: none"> - breakage in drum connection pipe (black). - disconnection in relative connector. - channel 4 instrument 3 pump faulty. - channel 4 instrument 3 pressure sensor faulty. - PLC card faulty. - pump broken 	<ul style="list-style-type: none"> - check pipe integrity and eventually replace it. - check if the connector is properly fastened to the instrument. - check and/or replace channel 4 instrument 3 pump. - check and/or replace channel 4 instrument 3 pressure sensor. - check and/or replace sensor control card/s and channel pump command. - check and/or replace the pump 	X in part	X in part	X

HAKKO ALARM MESSAGE	ALARM DESCRIPTION	POSSIBLE CAUSES	SOLUTION	OPER.	SUPERV.	MANUF.
43 CONTROL CONNECTION SET 1 LEAK TEST	At the beginning of cycle, the leak test has not reached the minimum set pressure.	<ul style="list-style-type: none"> - pump broken. - electronic sensor for pressure broken. - PLC card faulty. 	<ul style="list-style-type: none"> - check and/or replace the pump. - check and/or replace the electronic sensor. - check pipe integrity and eventually replace it. - check connections and eventually replace it. - check oring integrity and eventually replace it. - check and/or replace sensor control card/s and channel pump command. 	X in part	X in part	X
44 CONTROL CONNECTION SET 2 LEAK TEST	At the beginning of cycle, the leak test has not reached the minimum set pressure.	<ul style="list-style-type: none"> - pump broken. - electronic sensor for pressure broken. - PLC card faulty. 	<ul style="list-style-type: none"> - check and/or replace the pump. - check and/or replace the electronic sensor. - check pipe integrity and eventually replace it. - check connections and eventually replace it. - check oring integrity and eventually replace it. - check and/or replace sensor control card/s and channel pump command. 	X in part	X in part	X

HAKKO ALARM MESSAGE	ALARM DESCRIPTION	POSSIBLE CAUSES	SOLUTION	OPER.	SUPERV.	MANUF.
45 CONTROL CONNECTION SET 3 LEAK TEST	At the beginning of cycle, the leak test has not reached the minimum set pressure.	<ul style="list-style-type: none"> - pump broken. - electronic sensor for pressure broken. - PLC card faulty. 	<ul style="list-style-type: none"> - check and/or replace the pump. - check and/or replace the electronic sensor. - check pipe integrity and eventually replace it. - check connections and eventually replace it. - check oring integrity and eventually replace it. - check and/or replace sensor control card/s and channel pump command. 	X in part	X in part	X
46 EVENT REGISTR. FAILUERS (TIME)	It is not possible to record cycle events.	<ul style="list-style-type: none"> - PLC fault/malfunction. 	<ul style="list-style-type: none"> - check and eventually reset set the system. 			X
47 CHA.3 SET 3 OBSTRUCTED	During the cycle an obstruction was found in the endoscopic channel connected to channel 3 instrument 3 with ON-OFF function	<ul style="list-style-type: none"> - organic material or of a different nature obstructing the endoscopic channel of the instrument or the connection pipe to the instrument. - channel 3 instrument 3 pressure sensor faulty. - incorrect connector connection or bent connector pipe. - endoscopic instrument maintenance carried out badly (reduction in channel diameter different from the original). - set parameters incorrect. - endoscope code insertion different from that attributed. 	<ul style="list-style-type: none"> - verify openness of the channel and the connection pipe. - check and/or replace the pressure sensor. - check that the pipe is correctly positioned inside the drum and the connector. - check that the set maximum pressure parameters are correct. - check that the code recalled for the instruments matches the inserted instrument. - as a final analysis have the instrument checked by an authorised technical assistance. 	X in part	X in part	X

HAKKO ALARM MESSAGE	ALARM DESCRIPTION	POSSIBLE CAUSES	SOLUTION	OPER.	SUPERV.	MANUF.
48 CHA.4 SET 3 OBSTRUCTED	During the cycle an obstruction was found in the endoscopic channel connected to channel 4 instrument 3 with ON-OFF function	<ul style="list-style-type: none"> - organic material or of a different nature obstructing the endoscopic channel of the instrument or the connection pipe to the instrument. - channel 4 instrument 3 pressure sensor faulty. - incorrect connector connection or bent connector pipe. - endoscopic instrument maintenance carried out badly (reduction in channel diameter different from the original). - set parameters incorrect. - endoscope code insertion different from that attributed. 	<ul style="list-style-type: none"> - verify openness of the channel and the connection pipe. - check and/or replace the pressure sensor. - check that the pipe is correctly positioned inside the drum and the connector. - check that the set maximum pressure parameters are correct. - check that the code recalled for the instruments matches the inserted instrument. - as a final analysis have the instrument checked by an authorised technical assistance. 	X in part	X in part	X
49 INCONGRUITY LEAK TEST CAP 3	When the control is activated, the instrument presence sensor is active with the endoscope in the position 3.	<ul style="list-style-type: none"> - sensor failure - wrong connection of operator - wrong insertion of operator on touch-screen 	<ul style="list-style-type: none"> - replace or calibrate the sensor - check the correct connection of endoscope 	X in part	X	X
50 W.ARMS FLOW TR. OUT OF LIM.-	During the cycle the flow sensor for controlling the passage of liquid to the washing impellers has read a value lower than the set minimum.	<ul style="list-style-type: none"> - recirculation pump malfunction. - no filter in chamber (recirculation pump cavitation - sucks air). - flow sensor broken. - control board electric contact or flow sensor disconnected. 	<ul style="list-style-type: none"> - check the operational state of the wash pump and/or replace it. - check that the filter is in the tank and is properly clean. - check and/or replace the flow sensor. - check and/or replace the flow sensor electric connections 	X in part	X in part	X

HAKKO ALARM MESSAGE	ALARM DESCRIPTION	POSSIBLE CAUSES	SOLUTION	OPER.	SUPERV.	MANUF.
51 FLOWM.WATER 1	The <u>control (J1)</u> flowmeter for water 1 detects an exceed of pulses over the threshold of P7.20 with controlled water solenoid valve closed, excluding the pulses counted when the sanification solenoid valve is open with washing pump active (sanification washing water flow to flowmeter water 1).	<ul style="list-style-type: none"> - flow sensor broken. - set parameter less than 90 impulses. - spiral water pneumatic valve deactivated/faulty. 	<ul style="list-style-type: none"> - check and/or replace the flow sensor. - check the set parameters (default 140). - check that the spiral water pneumatic valve is open during washing. 	X in part	X in part	X
52 FLOWM.WATER 1	<p>(Diagnostics activated if P8.26=0)</p> <p>The <u>redundancy flowmeter (J4 on slave2)</u> for water 1 detects an excess of pulses over the threshold of P7.20 with controlled water solenoid valve closed, excluding the pulses counted when the sanification solenoid valve is open with washing pump active (sanification washing water flow to flowmeter water 1).</p>	<ul style="list-style-type: none"> - flow sensor malfunction. - the channel obstruction (organic material or of another nature). - channel pipe 1 bent/badly positioned. - error in the instrument connector connection. - selected endoscope different from that connected. 	<ul style="list-style-type: none"> - check and/or replace the flow sensor. - check both the endoscopic channel (with pipe-cleaner) and channel 1 connection pipe (brown). - check that the pipe is correctly positioned in the drum (avoid necking or 90° bends). - check that the connector is connected to the correct endoscopic channel. - check that the correct endoscope has been selected on the cycle start monitor. 	X in part	X in part	X

HAKKO ALARM MESSAGE	ALARM DESCRIPTION	POSSIBLE CAUSES	SOLUTION	OPER.	SUPERV.	MANUF.
53 CHA.2 SET 3 OBSTRUCTED	During the cycle in the flow control stage, the system has detected an obstruction in channel 2 instrument 3.	<ul style="list-style-type: none"> - flow sensor malfunction. - the channel obstruction (organic material or of another nature). - channel pipe 2 bent/badly positioned. - error in the instrument connector connection. - selected endoscope different from that connected. 	<ul style="list-style-type: none"> - check and/or replace the flow sensor. - check both the endoscopic channel (with pipe-cleaner) and channel 2 connection pipe (green). - check that the pipe is correctly positioned in the drum (avoid necking or 90° bends). - check that the connector is connected to the correct endoscopic channel. - check that the correct endoscope has been selected on the cycle start monitor. 	X in part	X in part	X
54 CHA.3 SET 3 OBSTRUCTED	During the cycle in the flow control stage, the system has detected an obstruction in channel 3 instrument 3.	<ul style="list-style-type: none"> - flow sensor malfunction. - the channel obstruction (organic material or of another nature). - channel pipe 3 bent/badly positioned. - error in the instrument connector connection. - selected endoscope different from that connected. 	<ul style="list-style-type: none"> - check and/or replace the flow sensor. - check both the endoscopic channel (with pipe-cleaner) and channel 3 connection pipe (blue). - check that the pipe is correctly positioned in the drum (avoid necking or 90° bends). - check that the connector is connected to the correct endoscopic channel. - check that the correct endoscope has been selected on the cycle start monitor. 	X in part	X in part	X

HAKKO ALARM MESSAGE	ALARM DESCRIPTION	POSSIBLE CAUSES	SOLUTION	OPER.	SUPERV.	MANUF.
55 CHA.4 SET 3 OBSTRUCTED	During the cycle in the flow control stage, the system has detected an obstruction in channel 4 instrument 3.	<ul style="list-style-type: none"> - flow sensor malfunction. - the channel obstruction (organic material or of another nature). - channel pipe 4 bent/badly positioned. - error in the instrument connector connection. - selected endoscope different from that connected. 	<ul style="list-style-type: none"> - check and/or replace the flow sensor. - check both the endoscopic channel (with pipe-cleaner) and channel 4 connection pipe (yellow). - check that the pipe is correctly positioned in the drum (avoid necking or 90° bends). - check that the connector is connected to the correct endoscopic channel. - check that the correct endoscope has been selected on the cycle start monitor. 	X in part	X in part	X
56 CHA.5 SET 3 OBSTRUCTED	During the cycle in the flow control stage, the system has detected an obstruction in channel 5 instrument 3.	<ul style="list-style-type: none"> - flow sensor malfunction. - the channel obstruction (organic material or of another nature). - channel pipe 5 bent/badly positioned. - error in the instrument connector connection. - selected endoscope different from that connected. 	<ul style="list-style-type: none"> - check and/or replace the flow sensor. - check both the endoscopic channel (with pipe-cleaner) and channel 5 connection pipe (grey). - check that the pipe is correctly positioned in the drum (avoid necking or 90° bends). - check that the connector is connected to the correct endoscopic channel. - check that the correct endoscope has been selected on the cycle start monitor. 	X in part	X in part	X

HAKKO ALARM MESSAGE	ALARM DESCRIPTION	POSSIBLE CAUSES	SOLUTION	OPER.	SUPERV.	MANUF.
57 CHA.6 SET 3 OBSTRUCTED	During the cycle in the flow control stage, the system has detected an obstruction in channel 6 instrument 3 when pump is continuous working.	<ul style="list-style-type: none"> - flow sensor malfunction. - the channel obstruction (organic material or of another nature). - channel pipe 6 bent/badly positioned. - error in the instrument connector connection. - selected endoscope different from that connected. 	<ul style="list-style-type: none"> - check and/or replace the flow sensor. - check both the endoscopic channel (with pipe-cleaner) and channel 6 connection pipe (red). - check that the pipe is correctly positioned in the drum (avoid necking or 90° bends). - check that the connector is connected to the correct endoscopic channel. - check that the correct endoscope has been selected on the cycle start monitor. 	X in part	X in part	X
58 CHA.7 SET 3 OBSTRUCTED	During the cycle in the flow control stage, the system has detected an obstruction in channel 7 instrument 3 when pump is continuous working.	<ul style="list-style-type: none"> - flow sensor malfunction. - the channel obstruction (organic material or of another nature). - channel pipe 7 bent/badly positioned. - error in the instrument connector connection. - selected endoscope different from that connected. 	<ul style="list-style-type: none"> - check and/or replace the flow sensor. - check both the endoscopic channel (with pipe-cleaner) and channel 7 connection pipe (black). - check that the pipe is correctly positioned in the drum (avoid necking or 90° bends). - check that the connector is connected to the correct endoscopic channel. - check that the correct endoscope has been selected on the cycle start monitor. 	X in part	X in part	X

HAKKO ALARM MESSAGE	ALARM DESCRIPTION	POSSIBLE CAUSES	SOLUTION	OPER.	SUPERV.	MANUF.
59 CHA.3 SET 1 DISCONNECTED	During the cycle the connector in channel 3 instrument 1 has detached from the instrument	<ul style="list-style-type: none"> - connector not connected to the instrument perfectly. - connector worn. - channel 3 instrument 1 pressure sensor faulty. - channel 3 instrument 1 pipe broken (red). 	<ul style="list-style-type: none"> - wear personal protective equipment and check that the joint is connected correctly, in case reconnect and restart the cycle. - replace the connector if worn or has a broken o ring seal. - check and/or replace the pressure sensor. - check and/or replace the channel pipe. 	X in part	X in part	X
60 CHA.4 SET 1 DISCONNECTED	During the cycle the connector in channel 4 instrument 1 has detached from the instrument.	<ul style="list-style-type: none"> - connector not connected to the instrument perfectly. - connector worn. - channel 4 instrument 1 pressure sensor faulty. - channel 4 instrument 1 pipe broken (black). 	<ul style="list-style-type: none"> - wear personal protective equipment and check that the joint is connected correctly, in case reconnect and restart the cycle. - replace the connector if worn or has a broken o ring seal. - check and/or replace the pressure sensor. - check and/or replace the channel pipe. 	X in part	X in part	X
61 DRYING HEATING EMERGENCY	The air temperature has exceeded 110°C during the drying phase into the heating elements.	<ul style="list-style-type: none"> - PLC failure - heating element remote control switch/relay faulty. 	<ul style="list-style-type: none"> - check the command board controlling the heating element remote control switch. - check the command board controlling the heating element remote control switch. 			X
62 SECUR. INTERVENTION LOADING DOOR						
63 SECUR. INTERVENTION DRAIN DOOR						

HAKKO ALARM MESSAGE	ALARM DESCRIPTION	POSSIBLE CAUSES	SOLUTION	OPER.	SUPERV.	MANUF.
66 CHA.3 SET 2 DISCONNECTED	During the cycle the connector in channel 3 instrument 2 has detached from the instrument	<ul style="list-style-type: none"> - connector not connected to the instrument perfectly. - connector worn. - channel 3 instrument 2 pressure sensor faulty. - channel 3 instrument 2 pipe broken (red). 	<ul style="list-style-type: none"> - wear personal protective equipment and check that the joint is connected correctly, in case reconnect and restart the cycle. - replace the connector if worn or has a broken o ring seal. - check and/or replace the pressure sensor. - check and/or replace the channel pipe. 	X in part	X in part	X
67 CHA.4 SET 2 DISCONNECTED	During the cycle the connector in channel 4 instrument 2 has detached from the instrument.	<ul style="list-style-type: none"> - connector not connected to the instrument perfectly. - connector worn. - channel 4 instrument 2 pressure sensor faulty. - channel 4 instrument 2 pipe broken (black). 	<ul style="list-style-type: none"> - wear personal protective equipment and check that the joint is connected correctly, in case reconnect and restart the cycle. - replace the connector if worn or has a broken o ring seal. - check and/or replace the pressure sensor. - check and/or replace the channel pipe. 	X in part	X in part	X
68 CHA.3 SET 3 DISCONNECTED	During the cycle the connector in channel 3 instrument 3 has detached from the instrument	<ul style="list-style-type: none"> - connector not connected to the instrument perfectly. - connector worn. - channel 3 instrument 3 pressure sensor faulty. - channel 3 instrument 3 pipe broken (red). 	<ul style="list-style-type: none"> - wear personal protective equipment and check that the joint is connected correctly, in case reconnect and restart the cycle. - replace the connector if worn or has a broken o ring seal. - check and/or replace the pressure sensor. - check and/or replace the channel pipe. 	X in part	X in part	X

HAKKO ALARM MESSAGE	ALARM DESCRIPTION	POSSIBLE CAUSES	SOLUTION	OPER.	SUPERV.	MANUF.
69 CHA.4 SET 3 DISCONNECTED	During the cycle the connector in channel 4 instrument 3 has detached from the instrument.	<ul style="list-style-type: none"> - connector not connected to the instrument perfectly. - connector worn. - channel 4 instrument 3 pressure sensor faulty. - channel 4 instrument 3 pipe broken (black). 	<ul style="list-style-type: none"> - wear personal protective equipment and check that the joint is connected correctly, in case reconnect and restart the cycle. - replace the connector if worn or has a broken o ring seal. - check and/or replace the pressure sensor. - check and/or replace the channel pipe. 	X in part	X in part	X
70 CHA.1 SET 3 DISCONNECTED	During the cycle the connector of channel 1 instrument 3 has detached.	<ul style="list-style-type: none"> - disconnected channel connector. - breakage in connector pipe. - error in the connection of the connector to the instrument. - selected endoscope different from that connected. 	<ul style="list-style-type: none"> - check and/or replace the connector. - check and/or replace the connector pipe. - check that the connector is connected to the correct endoscopic channel. - check that the correct endoscope has been selected on the cycle start monitor. 	X in part	X in part	X
71 CHA.2 SET 3 DISCONNECTED	During the cycle the connector of channel 2 instrument 3 has detached.	<ul style="list-style-type: none"> - disconnected channel connector. - breakage in connector pipe. - error in the connection of the connector to the instrument. - selected endoscope different from that connected. 	<ul style="list-style-type: none"> - check and/or replace the connector. - check and/or replace the connector pipe. - check that the connector is connected to the correct endoscopic channel. - check that the correct endoscope has been selected on the cycle start monitor. 	X in part	X in part	X

HAKKO ALARM MESSAGE	ALARM DESCRIPTION	POSSIBLE CAUSES	SOLUTION	OPER.	SUPERV.	MANUF.
72 CHA.3 SET 3 DISCONNECTED	During the cycle the connector of channel 3 instrument 3 has detached.	<ul style="list-style-type: none"> - disconnected channel connector. - breakage in connector pipe. - error in the connection of the connector to the instrument. - selected endoscope different from that connected. 	<ul style="list-style-type: none"> - check and/or replace the connector. - check and/or replace the connector pipe. - check that the connector is connected to the correct endoscopic channel. - check that the correct endoscope has been selected on the cycle start monitor. 	X in part	X in part	X
73 CHA.4 SET 3 DISCONNECTED	During the cycle the connector of channel 4 instrument 3 has detached.	<ul style="list-style-type: none"> - disconnected channel connector. - breakage in connector pipe. - error in the connection of the connector to the instrument. - selected endoscope different from that connected. 	<ul style="list-style-type: none"> - check and/or replace the connector. - check and/or replace the connector pipe. - check that the connector is connected to the correct endoscopic channel. - check that the correct endoscope has been selected on the cycle start monitor. 	X in part	X in part	X
74 CHA.5 SET 3 DISCONNECTED	During the cycle the connector of channel 5 instrument 3 has detached.	<ul style="list-style-type: none"> - disconnected channel connector. - breakage in connector pipe. - error in the connection of the connector to the instrument. - selected endoscope different from that connected. 	<ul style="list-style-type: none"> - check and/or replace the connector. - check and/or replace the connector pipe. - check that the connector is connected to the correct endoscopic channel. - check that the correct endoscope has been selected on the cycle start monitor. 	X in part	X in part	X

HAKKO ALARM MESSAGE	ALARM DESCRIPTION	POSSIBLE CAUSES	SOLUTION	OPER.	SUPERV.	MANUF.
75 CHA.6 SET 3 DISCONNECTED	During the cycle the connector of channel 6 instrument 3 has detached.	<ul style="list-style-type: none"> - disconnected channel connector. - breakage in connector pipe. - error in the connection of the connector to the instrument. - selected endoscope different from that connected. 	<ul style="list-style-type: none"> - check and/or replace the connector. - check and/or replace the connector pipe. - check that the connector is connected to the correct endoscopic channel. - check that the correct endoscope has been selected on the cycle start monitor. 	X in part	X in part	X
76 CHA.7 SET 3 DISCONNECTED	During the cycle the connector of channel 7 instrument 3 has detached.	<ul style="list-style-type: none"> - disconnected channel connector. - breakage in connector pipe. - error in the connection of the connector to the instrument. - selected endoscope different from that connected. 	<ul style="list-style-type: none"> - check and/or replace the connector. - check and/or replace the connector pipe. - check that the connector is connected to the correct endoscopic channel. - check that the correct endoscope has been selected on the cycle start monitor. 	X in part	X in part	X
77 EXCESSIVE PRESSURE LT SET 3	During the cycle the seal test has exceeded the maximum pressure parameter admitted within the endoscope on instrument 3.	<ul style="list-style-type: none"> - seal test air opener electrovalve seeping (dirty/worn) with contemporary fault in pressure sensor or seal test air pump command relay faulty. - maximum inserted parameter less than 0,4 bar. - seal test in alarm during 90°C thermal disinfection. 	<ul style="list-style-type: none"> - check and/or replace the seal test air opener electrovalve shutter. - check and/or replace the seal test pump command board. - change the seal test maximum pressure parameter. 			X

HAKKO ALARM MESSAGE	ALARM DESCRIPTION	POSSIBLE CAUSES	SOLUTION	OPER.	SUPERV.	MANUF.
78 EXCESSIVE PRESSURE LT SET 1	During the cycle the seal test has exceeded the maximum pressure parameter admitted within the endoscope on instrument 1.	<ul style="list-style-type: none"> - seal test air opener electrovalve seeping (dirty/worn) with contemporary fault in pressure sensor or seal test air pump command relay faulty. - maximum inserted parameter less than 0,4 bar. - seal test in alarm during 90°C thermal disinfection. 	<ul style="list-style-type: none"> - check and/or replace the seal test air opener electrovalve shutter. - check and/or replace the seal test pump command board. - change the seal test maximum pressure parameter. 			X
79 EXCESSIVE PRESSURE LT SET 2	During the cycle the seal test has exceeded the maximum pressure parameter admitted within the endoscope on instrument 2.	<ul style="list-style-type: none"> - seal test air opener electrovalve seeping (dirty/worn) with contemporary fault in pressure sensor or seal test air pump command relay faulty. - maximum inserted parameter less than 0,4 bar. - seal test in alarm during 90°C thermal disinfection. 	<ul style="list-style-type: none"> - check and/or replace the seal test air opener electrovalve shutter. - check and/or replace the seal test pump command board. - change the seal test maximum pressure parameter. 			X
80 CHA.3 SET 1 OBSTRUCTED PR+	During the cycle in the pressure control stage, the system has detected an obstruction in channel 3 instrument 1 when pump is continuous working.	<ul style="list-style-type: none"> - pressure sensor malfunction. - the channel obstruction (organic material or of another nature). - channel pipe 3 bent/badly positioned. - error in the instrument connector connection. - selected endoscope different from that connected. 	<ul style="list-style-type: none"> - check and/or replace the pressure sensor. - check both the endoscopic channel (with pipe-cleaner) and channel 3 connection pipe (red). - check that the pipe is correctly positioned in the drum (avoid necking or 90° bends). - check that the connector is connected to the correct endoscopic channel. - check that the correct endoscope has been selected on the cycle start monitor. 	X in part	X in part	X

HAKKO ALARM MESSAGE	ALARM DESCRIPTION	POSSIBLE CAUSES	SOLUTION	OPER.	SUPERV.	MANUF.
81 CHA.4 SET 1 OBSTRUCTED PR+	During the cycle in the pressure control stage, the system has detected an obstruction in channel 4 instrument 1 when pump is continuous working.	<ul style="list-style-type: none"> - pressure sensor malfunction. - the channel obstruction (organic material or of another nature). - channel pipe 4 bent/badly positioned. - error in the instrument connector connection. - selected endoscope different from that connected. 	<ul style="list-style-type: none"> - check and/or replace the pressure sensor. - check both the endoscopic channel (with pipe-cleaner) and channel 4 connection pipe (black). - check that the pipe is correctly positioned in the drum (avoid necking or 90° bends). - check that the connector is connected to the correct endoscopic channel. - check that the correct endoscope has been selected on the cycle start monitor. 	X in part	X in part	X
82 CHA.3 SET 2 OBSTRUCTED PR+	During the cycle in the pressure control stage, the system has detected an obstruction in channel 3 instrument 2 when pump is continuous working.	<ul style="list-style-type: none"> - pressure sensor malfunction. - the channel obstruction (organic material or of another nature). - channel pipe 3 bent/badly positioned. - error in the instrument connector connection. - selected endoscope different from that connected. 	<ul style="list-style-type: none"> - check and/or replace the pressure sensor. - check both the endoscopic channel (with pipe-cleaner) and channel 3 connection pipe (red). - check that the pipe is correctly positioned in the drum (avoid necking or 90° bends). - check that the connector is connected to the correct endoscopic channel. - check that the correct endoscope has been selected on the cycle start monitor. 	X in part	X in part	X

HAKKO ALARM MESSAGE	ALARM DESCRIPTION	POSSIBLE CAUSES	SOLUTION	OPER.	SUPERV.	MANUF.
83 CHA.4 SET 2 OBSTRUCTED PR+	During the cycle in the pressure control stage, the system has detected an obstruction in channel 4 instrument 2 when pump is continuous working.	<ul style="list-style-type: none"> - pressure sensor malfunction. - the channel obstruction (organic material or of another nature). - channel pipe 4 bent/badly positioned. - error in the instrument connector connection. - selected endoscope different from that connected. 	<ul style="list-style-type: none"> - check and/or replace the pressure sensor. - check both the endoscopic channel (with pipe-cleaner) and channel 4 connection pipe (black). - check that the pipe is correctly positioned in the drum (avoid necking or 90° bends). - check that the connector is connected to the correct endoscopic channel. - check that the correct endoscope has been selected on the cycle start monitor. 	X in part	X in part	X
84 SET 1 LEAK FAILURES	During the cycle the endoscopic instrument in position 1 has lost more than the value set in bars in the control time set in seconds.	<ul style="list-style-type: none"> - leaking endoscope. - leak test connector worn. - leak test oring worn or broken. - connection pipe (neutral colour) damaged/torn. - oring (pair - position 8) for connection to endoscope drum worn or broken. - machine-drum connection joint not leaking. - charge or discharge electrovalve seeping. - pressure sensor malfunction. 	<ul style="list-style-type: none"> - manually test the endoscope according to the procedures indicated by the manufacturer. - check if the leak test connector is worn or has a worn/broken leaking oring. - check and/or replace the leak test connection pipe. - check and/or replace the o rings on the machine-drum connection connector. - check the shutters of the two leak test 1 unit electrovalves. - check and/or replace the leak test 1 pressure sensor 			X

HAKKO ALARM MESSAGE	ALARM DESCRIPTION	POSSIBLE CAUSES	SOLUTION	OPER.	SUPERV.	MANUF.
85 SET 2 LEAK FAILURES	During the cycle the endoscopic instrument in position 2 has lost more than the value set in bars in the control time set in seconds.	<ul style="list-style-type: none"> - leaking endoscope. - leak test connector worn. - leak test oring worn or broken. - connection pipe (neutral colour) damaged/torn. - oring (pair - position 8) for connection to endoscope drum worn or broken. - machine-drum connection joint not leaking. - charge or discharge electrovalve seeping. - pressure sensor malfunction. 	<ul style="list-style-type: none"> - manually test the endoscope according to the procedures indicated by the manufacturer. - check if the leak test connector is worn or has a worn/broken leaking oring. - check and/or replace the leak test connection pipe. - check and/or replace the o rings on the machine-drum connection connector. - check the shutters of the two leak testS 2 unit electrovalves. - check and/or replace the leak test 2 pressure sensor 			X
86 FAILURE DRAINING LEAK TEST	At the end of the cycle the pressure remaining inside the endoscope is higher than that set (0,01 bar)	<ul style="list-style-type: none"> - leak test 1 pressure sensor (expansion cylinder) faulty. - leak test 1 electrovalve discharge fault. - leak test 1 electrovalve discharge command card faulty. 	<ul style="list-style-type: none"> - check and/or replace the pressure sensor. - check and/or replace the leak test air discharge shutter coil. - check that during the air discharge phase the card feeds the electrovalve, replace it in the case of malfunction. 			X
87 REFILL ALARM LT SET 1	The system has exceeded the number of refill leak test set by parameter in set 1.	<ul style="list-style-type: none"> - problem on leak test instrument. - leak from idraulic circuit of leak test. - wrong value of parameter. 	<ul style="list-style-type: none"> - check the instrument leak test. - check the o-ring and connection of leak test. - check the pipe connection. - check the value parameter. 		X	X

HAKKO ALARM MESSAGE	ALARM DESCRIPTION	POSSIBLE CAUSES	SOLUTION	OPER.	SUPERV.	MANUF.
88 CHA.3 SET 3 OBSTRUCTED	During the cycle in the pressure control stage, the system has detected an obstruction in channel 3 instrument 3 when pump is continuous working.	<ul style="list-style-type: none"> - pressure sensor malfunction. - the channel obstruction (organic material or of another nature). - channel pipe 3 bent/badly positioned. - error in the instrument connector connection. - selected endoscope different from that connected. 	<ul style="list-style-type: none"> - check and/or replace the pressure sensor. - check both the endoscopic channel (with pipe-cleaner) and channel 3 connection pipe (red). - check that the pipe is correctly positioned in the drum (avoid necking or 90° bends). - check that the connector is connected to the correct endoscopic channel. - check that the correct endoscope has been selected on the cycle start monitor. 	X in part	X in part	X
89 CHA.4 SET 3 OBSTRUCTED	During the cycle in the pressure control stage, the system has detected an obstruction in channel 4 instrument 3 when pump is continuous working.	<ul style="list-style-type: none"> - pressure sensor malfunction. - the channel obstruction (organic material or of another nature). - channel pipe 4 bent/badly positioned. - error in the instrument connector connection. - selected endoscope different from that connected. 	<ul style="list-style-type: none"> - check and/or replace the pressure sensor. - check both the endoscopic channel (with pipe-cleaner) and channel 4 connection pipe (black). - check that the pipe is correctly positioned in the drum (avoid necking or 90° bends). - check that the connector is connected to the correct endoscopic channel. - check that the correct endoscope has been selected on the cycle start monitor. 	X in part	X in part	X

HAKKO ALARM MESSAGE	ALARM DESCRIPTION	POSSIBLE CAUSES	SOLUTION	OPER.	SUPERV.	MANUF.
90 SET 3 LEAK FAILURES	During the cycle the endoscopic instrument in position 3 has lost more than the value set in bars in the control time set in seconds.	<ul style="list-style-type: none"> - leaking endoscope. - leak test connector worn. - leak test oring worn or broken. - connection pipe (neutral colour) damaged/torn. - oring (pair - position 8) for connection to endoscope drum worn or broken. - machine-drum connection joint not leaking. - charge or discharge electrovalve seeping. - pressure sensor malfunction. 	<ul style="list-style-type: none"> - manually test the endoscope according to the procedures indicated by the manufacturer. - check if the leak test connector is worn or has a worn/broken leaking oring. - check and/or replace the leak test connection pipe. - check and/or replace the o rings on the machine-drum connection connector. - check the shutters of the two leak tests 1 unit electrovalves. - check and/or replace the leak test 3 pressure sensor 			X
91 BOTH DOORS OPEN	During the cycle one or both the machine doors have opened	<ul style="list-style-type: none"> - breakage or fault in the door lock 	<ul style="list-style-type: none"> - check that the door lock is working properly. - check that the chamber filter is working properly. 			X
92 CHEM. DOS. TEMP TOO HIGH	During the chemical loading phase, the detected temperature is higher than that set by 5°C	<ul style="list-style-type: none"> - temperature of water entering the machine is too high. - resistance power supply control switch faulty (connect relay broken or faulty). - incorrect setting of the cycle parameters. 	<ul style="list-style-type: none"> - check the machine water feed mixer. - check and/or replace the resistance control switch and the command relay board. - check cycle settings in the chemical extraction phases, these should not be lower than the temperature of the water entering the machine 			X
93 NO HEAT. FOR LOW LEVEL	During the heating phase the water level has dropped below that set.	<ul style="list-style-type: none"> - tank level sensor faulty. - loss of water from hydraulic circuit 	<ul style="list-style-type: none"> - check/clean and/or replace the wash tank minimum water level. - check and/or replace the wash tank water discharge valve. - check and remedy any leaks in the hydraulic circuit. 			X

HAKKO ALARM MESSAGE	ALARM DESCRIPTION	POSSIBLE CAUSES	SOLUTION	OPER.	SUPERV.	MANUF.
94 WATER LEAKS 1	The system detects a water flow during a phase of not water filling.	- filling water valve and filling water pump faulty. - filter sanification valve faulty.	- check/clean and/or replace the filling water valve. - check/clean and/or replace the filling water pump. - check/clean and/or replace the filter sanification valve.			X
95 WATER LEAKS 2	The system detects a water flow during a phase of not water filling.	- filling water valve and filling water pump faulty. - filter sanification valve faulty.	- check/clean and/or replace the filling water valve. - check/clean and/or replace the filling water pump. - check/clean and/or replace the filter sanification valve.			X
96 CHEMICAL LEAKS 1	The system detects a chemical flow during a phase of not chemical 1 loading.	- dosing pump in function - flowmeter failure	- check chemical pump command - check and replace the flowmeter		X	X
97 CHEMICAL LEAKS 2	The system detects a chemical flow during a phase of not chemical 2 loading.	- dosing pump in function - flowmeter failure	- check chemical pump command - check and replace the flowmeter		X	X
98 CHEMICAL LEAKS 3	The system detects a chemical flow during a phase of not chemical 3 loading.	- dosing pump in function - flowmeter failure	- check chemical pump command - check and replace the flowmeter		X	X
99 CHEMICAL LEAKS 4	The system detects a chemical flow during a phase of not chemical 4 loading.	- dosing pump in function - flowmeter failure	- check chemical pump command - check and replace the flowmeter		X	X

HAKKO ALARM MESSAGE	ALARM DESCRIPTION	POSSIBLE CAUSES	SOLUTION	OPER.	SUPERV.	MANUF.
100 CHA.1 SET 1 OBSTRUCTED FL-	During the cycle in the flow control stage, the system has detected an obstruction in channel 1 instrument 1.	<ul style="list-style-type: none"> - flow sensor malfunction. - the channel obstruction (organic material or of another nature). - channel pipe 1 bent/badly positioned. - error in the instrument connector connection. - selected endoscope different from that connected. 	<ul style="list-style-type: none"> - check and/or replace the flow sensor. - check both the endoscopic channel (with pipe-cleaner) and channel 1 connection pipe (brown). - check that the pipe is correctly positioned in the drum (avoid necking or 90° bends). - check that the connector is connected to the correct endoscopic channel. - check that the correct endoscope has been selected on the cycle start monitor. 	X in part	X in part	X
101 CHA.2 SET 1 OBSTRUCTED FL-	During the cycle in the flow control stage, the system has detected an obstruction in channel 2 instrument 1.	<ul style="list-style-type: none"> - flow sensor malfunction. - the channel obstruction (organic material or of another nature). - channel pipe 2 bent/badly positioned. - error in the instrument connector connection. - selected endoscope different from that connected. 	<ul style="list-style-type: none"> - check and/or replace the flow sensor. - check both the endoscopic channel (with pipe-cleaner) and channel 2 connection pipe (green). - check that the pipe is correctly positioned in the drum (avoid necking or 90° bends). - check that the connector is connected to the correct endoscopic channel. - check that the correct endoscope has been selected on the cycle start monitor. 	X in part	X in part	X

HAKKO ALARM MESSAGE	ALARM DESCRIPTION	POSSIBLE CAUSES	SOLUTION	OPER.	SUPERV.	MANUF.
102 CHA.3 SET 1 OBSTRUCTED FL-	During the cycle in the flow control stage, the system has detected an obstruction in channel 3 instrument 1.	<ul style="list-style-type: none"> - flow sensor malfunction. - the channel obstruction (organic material or of another nature). - channel pipe 3 bent/badly positioned. - error in the instrument connector connection. - selected endoscope different from that connected. 	<ul style="list-style-type: none"> - check and/or replace the flow sensor. - check both the endoscopic channel (with pipe-cleaner) and channel 3 connection pipe (blue). - check that the pipe is correctly positioned in the drum (avoid necking or 90° bends). - check that the connector is connected to the correct endoscopic channel. - check that the correct endoscope has been selected on the cycle start monitor. 	X in part	X in part	X
103 CHA.4 SET 1 OBSTRUCTED FL-	During the cycle in the flow control stage, the system has detected an obstruction in channel 4 instrument 1.	<ul style="list-style-type: none"> - flow sensor malfunction. - the channel obstruction (organic material or of another nature). - channel pipe 4 bent/badly positioned. - error in the instrument connector connection. - selected endoscope different from that connected. 	<ul style="list-style-type: none"> - check and/or replace the flow sensor. - check both the endoscopic channel (with pipe-cleaner) and channel 4 connection pipe (yellow). - check that the pipe is correctly positioned in the drum (avoid necking or 90° bends). - check that the connector is connected to the correct endoscopic channel. - check that the correct endoscope has been selected on the cycle start monitor. 	X in part	X in part	X

HAKKO ALARM MESSAGE	ALARM DESCRIPTION	POSSIBLE CAUSES	SOLUTION	OPER.	SUPERV.	MANUF.
104 CHA.5 SET 1 OBSTRUCTED FL-	During the cycle in the flow control stage, the system has detected an obstruction in channel 5 instrument 1.	<ul style="list-style-type: none"> - flow sensor malfunction. - the channel obstruction (organic material or of another nature). - channel pipe 5 bent/badly positioned. - error in the instrument connector connection. - selected endoscope different from that connected. 	<ul style="list-style-type: none"> - check and/or replace the flow sensor. - check both the endoscopic channel (with pipe-cleaner) and channel 5 connection pipe (grey). - check that the pipe is correctly positioned in the drum (avoid necking or 90° bends). - check that the connector is connected to the correct endoscopic channel. - check that the correct endoscope has been selected on the cycle start monitor. 	X in part	X in part	X
105 CHA.6 SET 1 OBSTRUCTED FL-	During the cycle in the flow control stage, the system has detected an obstruction in channel 6 instrument 1 when pump is continuous working.	<ul style="list-style-type: none"> - flow sensor malfunction. - the channel obstruction (organic material or of another nature). - channel pipe 6 bent/badly positioned. - error in the instrument connector connection. - selected endoscope different from that connected. 	<ul style="list-style-type: none"> - check and/or replace the flow sensor. - check both the endoscopic channel (with pipe-cleaner) and channel 6 connection pipe (red). - check that the pipe is correctly positioned in the drum (avoid necking or 90° bends). - check that the connector is connected to the correct endoscopic channel. - check that the correct endoscope has been selected on the cycle start monitor. 	X in part	X in part	X

HAKKO ALARM MESSAGE	ALARM DESCRIPTION	POSSIBLE CAUSES	SOLUTION	OPER.	SUPERV.	MANUF.
106 CHA.7 SET 1 OBSTRUCTED FL-	During the cycle in the flow control stage, the system has detected an obstruction in channel 7 instrument 1 when pump is continuous working.	<ul style="list-style-type: none"> - flow sensor malfunction. - the channel obstruction (organic material or of another nature). - channel pipe 7 bent/badly positioned. - error in the instrument connector connection. - selected endoscope different from that connected. 	<ul style="list-style-type: none"> - check and/or replace the flow sensor. - check both the endoscopic channel (with pipe-cleaner) and channel 7 connection pipe (black). - check that the pipe is correctly positioned in the drum (avoid necking or 90° bends). - check that the connector is connected to the correct endoscopic channel. - check that the correct endoscope has been selected on the cycle start monitor. 	X in part	X in part	X
107 CHA.1 SET 1 DISCONNECTED FL+	During the cycle the connector of channel 1 instrument 1 has detached.	<ul style="list-style-type: none"> - disconnected channel connector. - breakage in connector pipe. - error in the connection of the connector to the instrument. - selected endoscope different from that connected. 	<ul style="list-style-type: none"> - check and/or replace the connector. - check and/or replace the connector pipe. - check that the connector is connected to the correct endoscopic channel. - check that the correct endoscope has been selected on the cycle start monitor. 	X in part	X in part	X

HAKKO ALARM MESSAGE	ALARM DESCRIPTION	POSSIBLE CAUSES	SOLUTION	OPER.	SUPERV.	MANUF.
108 SANIFIC.FLOW	<p>With sanification valve open and washing pump active no water flow is detected in the hydraulic field of flowmeters water 1 (lack of new pulse from over P6.11).</p> <p>Alarm active when at least one of the two flowmeters of water dosing the condition above is verified (if P8.26=0).</p>	<ul style="list-style-type: none"> - disconnected channel connector. - breakage in connector pipe. - error in the connection of the connector to the instrument. - selected endoscope different from that connected. 	<ul style="list-style-type: none"> - check and/or replace the connector. - check and/or replace the connector pipe. - check that the connector is connected to the correct endoscopic channel. - check that the correct endoscope has been selected on the cycle start monitor. 	X in part	X in part	X
109 CHA.3 SET 1 DISCONNECTED FL+	<p>During the cycle the connector of channel 3 instrument 1 has detached.</p>	<ul style="list-style-type: none"> - disconnected channel connector. - breakage in connector pipe. - error in the connection of the connector to the instrument. - selected endoscope different from that connected. 	<ul style="list-style-type: none"> - check and/or replace the connector. - check and/or replace the connector pipe. - check that the connector is connected to the correct endoscopic channel. - check that the correct endoscope has been selected on the cycle start monitor. 	X in part	X in part	X
110 CHA.4 SET 1 DISCONNECTED FL+	<p>During the cycle the connector of channel 4 instrument 1 has detached.</p>	<ul style="list-style-type: none"> - disconnected channel connector. - breakage in connector pipe. - error in the connection of the connector to the instrument. - selected endoscope different from that connected. 	<ul style="list-style-type: none"> - check and/or replace the connector. - check and/or replace the connector pipe. - check that the connector is connected to the correct endoscopic channel. - check that the correct endoscope has been selected on the cycle start monitor. 	X in part	X in part	X

HAKKO ALARM MESSAGE	ALARM DESCRIPTION	POSSIBLE CAUSES	SOLUTION	OPER.	SUPERV.	MANUF.
111 CHA.5 SET 1 DISCONNECTED FL+	During the cycle the connector of channel 5 instrument 1 has detached.	<ul style="list-style-type: none"> - disconnected channel connector. - breakage in connector pipe. - error in the connection of the connector to the instrument. - selected endoscope different from that connected. 	<ul style="list-style-type: none"> - check and/or replace the connector. - check and/or replace the connector pipe. - check that the connector is connected to the correct endoscopic channel. - check that the correct endoscope has been selected on the cycle start monitor. 	X in part	X in part	X
112 CHA.6 SET 1 DISCONNECTED FL+	During the cycle the connector of channel 6 instrument 1 has detached.	<ul style="list-style-type: none"> - disconnected channel connector. - breakage in connector pipe. - error in the connection of the connector to the instrument. - selected endoscope different from that connected. 	<ul style="list-style-type: none"> - check and/or replace the connector. - check and/or replace the connector pipe. - check that the connector is connected to the correct endoscopic channel. - check that the correct endoscope has been selected on the cycle start monitor. 	X in part	X in part	X
113 CHA.7 SET 1 DISCONNECTED FL+	During the cycle the connector of channel 7 instrument 1 has detached.	<ul style="list-style-type: none"> - disconnected channel connector. - breakage in connector pipe. - error in the connection of the connector to the instrument. - selected endoscope different from that connected. 	<ul style="list-style-type: none"> - check and/or replace the connector. - check and/or replace the connector pipe. - check that the connector is connected to the correct endoscopic channel. - check that the correct endoscope has been selected on the cycle start monitor. 	X in part	X in part	X

HAKKO ALARM MESSAGE	ALARM DESCRIPTION	POSSIBLE CAUSES	SOLUTION	OPER.	SUPERV.	MANUF.
114 CHA.1 SET 2 OBSTRUCTED FL-	During the cycle in the flow control stage, the system has detected an obstruction in channel 1 instrument 2.	<ul style="list-style-type: none"> - flow sensor malfunction. - the channel obstruction (organic material or of another nature). - channel pipe 1 bent/badly positioned. - error in the instrument connector connection. - selected endoscope different from that connected. 	<ul style="list-style-type: none"> - check and/or replace the flow sensor. - check both the endoscopic channel (with pipe-cleaner) and channel 1 connection pipe (brown). - check that the pipe is correctly positioned in the drum (avoid necking or 90° bends). - check that the connector is connected to the correct endoscopic channel. - check that the correct endoscope has been selected on the cycle start monitor. 	X in part	X in part	X
115 CHA.2 SET 2 OBSTRUCTED FL-	During the cycle in the flow control stage, the system has detected an obstruction in channel 2 instrument 2.	<ul style="list-style-type: none"> - flow sensor malfunction. - the channel obstruction (organic material or of another nature). - channel pipe 2 bent/badly positioned. - error in the instrument connector connection. - selected endoscope different from that connected. 	<ul style="list-style-type: none"> - check and/or replace the flow sensor. - check both the endoscopic channel (with pipe-cleaner) and channel 2 connection pipe (green). - check that the pipe is correctly positioned in the drum (avoid necking or 90° bends). - check that the connector is connected to the correct endoscopic channel. - check that the correct endoscope has been selected on the cycle start monitor. 	X in part	X in part	X

HAKKO ALARM MESSAGE	ALARM DESCRIPTION	POSSIBLE CAUSES	SOLUTION	OPER.	SUPERV.	MANUF.
116 CHA.3 SET 2 OBSTRUCTED FL-	During the cycle in the flow control stage, the system has detected an obstruction in channel 3 instrument 2.	<ul style="list-style-type: none"> - flow sensor malfunction. - the channel obstruction (organic material or of another nature). - channel pipe 3 bent/badly positioned. - error in the instrument connector connection. - selected endoscope different from that connected. 	<ul style="list-style-type: none"> - check and/or replace the flow sensor. - check both the endoscopic channel (with pipe-cleaner) and channel 3 connection pipe (blue). - check that the pipe is correctly positioned in the drum (avoid necking or 90° bends). - check that the connector is connected to the correct endoscopic channel. - check that the correct endoscope has been selected on the cycle start monitor. 	X in part	X in part	X
117 CHA.4 SET 2 OBSTRUCTED FL-	During the cycle in the flow control stage, the system has detected an obstruction in channel 4 instrument 2.	<ul style="list-style-type: none"> - flow sensor malfunction. - the channel obstruction (organic material or of another nature). - channel pipe 4 bent/badly positioned. - error in the instrument connector connection. - selected endoscope different from that connected. 	<ul style="list-style-type: none"> - check and/or replace the flow sensor. - check both the endoscopic channel (with pipe-cleaner) and channel 4 connection pipe (yellow). - check that the pipe is correctly positioned in the drum (avoid necking or 90° bends). - check that the connector is connected to the correct endoscopic channel. - check that the correct endoscope has been selected on the cycle start monitor. 	X in part	X in part	X

HAKKO ALARM MESSAGE	ALARM DESCRIPTION	POSSIBLE CAUSES	SOLUTION	OPER.	SUPERV.	MANUF.
118 CHA.5 SET 2 OBSTRUCTED FL-	During the cycle in the flow control stage, the system has detected an obstruction in channel 5 instrument 2.	<ul style="list-style-type: none"> - flow sensor malfunction. - the channel obstruction (organic material or of another nature). - channel pipe 5 bent/badly positioned. - error in the instrument connector connection. - selected endoscope different from that connected. 	<ul style="list-style-type: none"> - check and/or replace the flow sensor. - check both the endoscopic channel (with pipe-cleaner) and channel 5 connection pipe (grey). - check that the pipe is correctly positioned in the drum (avoid necking or 90° bends). - check that the connector is connected to the correct endoscopic channel. - check that the correct endoscope has been selected on the cycle start monitor. 	X in part	X in part	X
119 CHA.6 SET 2 OBSTRUCTED FL-	During the cycle in the flow control stage, the system has detected an obstruction in channel 6 instrument 2 when pump is continuous working.	<ul style="list-style-type: none"> - flow sensor malfunction. - the channel obstruction (organic material or of another nature). - channel pipe 6 bent/badly positioned. - error in the instrument connector connection. - selected endoscope different from that connected. 	<ul style="list-style-type: none"> - check and/or replace the flow sensor. - check both the endoscopic channel (with pipe-cleaner) and channel 6 connection pipe (red). - check that the pipe is correctly positioned in the drum (avoid necking or 90° bends). - check that the connector is connected to the correct endoscopic channel. - check that the correct endoscope has been selected on the cycle start monitor. 	X in part	X in part	X

HAKKO ALARM MESSAGE	ALARM DESCRIPTION	POSSIBLE CAUSES	SOLUTION	OPER.	SUPERV.	MANUF.
120 CHA.7 SET 2 OBSTRUCTED FL-	During the cycle in the flow control stage, the system has detected an obstruction in channel 7 instrument 2 when pump is continuous working.	<ul style="list-style-type: none"> - flow sensor malfunction. - the channel obstruction (organic material or of another nature). - channel pipe 7 bent/badly positioned. - error in the instrument connector connection. - selected endoscope different from that connected. 	<ul style="list-style-type: none"> - check and/or replace the flow sensor. - check both the endoscopic channel (with pipe-cleaner) and channel 7 connection pipe (black). - check that the pipe is correctly positioned in the drum (avoid necking or 90° bends). - check that the connector is connected to the correct endoscopic channel. - check that the correct endoscope has been selected on the cycle start monitor. 	X in part	X in part	X
121 CHA.1 SET 2 DISCONNECTED FL+	During the cycle the connector of channel 1 instrument 2 has detached.	<ul style="list-style-type: none"> - disconnected channel connector. - breakage in connector pipe. - error in the connection of the connector to the instrument. - selected endoscope different from that connected. 	<ul style="list-style-type: none"> - check and/or replace the connector. - check and/or replace the connector pipe. - check that the connector is connected to the correct endoscopic channel. - check that the correct endoscope has been selected on the cycle start monitor. 	X in part	X in part	X
122 CHA.2 SET 2 DISCONNECTED FL+	During the cycle the connector of channel 2 instrument 2 has detached.	<ul style="list-style-type: none"> - disconnected channel connector. - breakage in connector pipe. - error in the connection of the connector to the instrument. - selected endoscope different from that connected. 	<ul style="list-style-type: none"> - check and/or replace the connector. - check and/or replace the connector pipe. - check that the connector is connected to the correct endoscopic channel. - check that the correct endoscope has been selected on the cycle start monitor. 	X in part	X in part	X

HAKKO ALARM MESSAGE	ALARM DESCRIPTION	POSSIBLE CAUSES	SOLUTION	OPER.	SUPERV.	MANUF.
123 CHA.3 SET 2 DISCONNECTED FL+	During the cycle the connector of channel 3 instrument 2 has detached.	<ul style="list-style-type: none"> - disconnected channel connector. - breakage in connector pipe. - error in the connection of the connector to the instrument. - selected endoscope different from that connected. 	<ul style="list-style-type: none"> - check and/or replace the connector. - check and/or replace the connector pipe. - check that the connector is connected to the correct endoscopic channel. - check that the correct endoscope has been selected on the cycle start monitor. 	X in part	X in part	X
124 CHA.4 SET 2 DISCONNECTED FL+	During the cycle the connector of channel 4 instrument 2 has detached.	<ul style="list-style-type: none"> - disconnected channel connector. - breakage in connector pipe. - error in the connection of the connector to the instrument. - selected endoscope different from that connected. 	<ul style="list-style-type: none"> - check and/or replace the connector. - check and/or replace the connector pipe. - check that the connector is connected to the correct endoscopic channel. - check that the correct endoscope has been selected on the cycle start monitor. 	X in part	X in part	X
125 CHA.5 SET 2 DISCONNECTED FL+	During the cycle the connector of channel 5 instrument 2 has detached.	<ul style="list-style-type: none"> - disconnected channel connector. - breakage in connector pipe. - error in the connection of the connector to the instrument. - selected endoscope different from that connected. 	<ul style="list-style-type: none"> - check and/or replace the connector. - check and/or replace the connector pipe. - check that the connector is connected to the correct endoscopic channel. - check that the correct endoscope has been selected on the cycle start monitor. 	X in part	X in part	X

HAKKO ALARM MESSAGE	ALARM DESCRIPTION	POSSIBLE CAUSES	SOLUTION	OPER.	SUPERV.	MANUF.
126 CHA.6 SET 2 DISCONNECTED FL+	During the cycle the connector of channel 6 instrument 2 has detached.	<ul style="list-style-type: none"> - disconnected channel connector. - breakage in connector pipe. - error in the connection of the connector to the instrument. - selected endoscope different from that connected. 	<ul style="list-style-type: none"> - check and/or replace the connector. - check and/or replace the connector pipe. - check that the connector is connected to the correct endoscopic channel. - check that the correct endoscope has been selected on the cycle start monitor. 	X in part	X in part	X
127 CHA.7 SET 2 DISCONNECTED FL+	During the cycle the connector of channel 7 instrument 2 has detached.	<ul style="list-style-type: none"> - disconnected channel connector. - breakage in connector pipe. - error in the connection of the connector to the instrument. - selected endoscope different from that connected. 	<ul style="list-style-type: none"> - check and/or replace the connector. - check and/or replace the connector pipe. - check that the connector is connected to the correct endoscopic channel. - check that the correct endoscope has been selected on the cycle start monitor. 	X in part	X in part	X

HAKKO ALARM MESSAGE	ALARM DESCRIPTION	POSSIBLE CAUSES	SOLUTION	OPER.	SUPERV.	MANUF.
128 CHA.3 SET 1 OBSTRUCTED PR.OFF	During the cycle an obstruction was found in the endoscopic channel connected to channel 3 instrument 1 with ON-OFF function	<ul style="list-style-type: none"> - organic material or of a different nature obstructing the endoscopic channel of the instrument or the connection pipe to the instrument. - channel 3 instrument 1 pressure sensor faulty. - incorrect connector connection or bent connector pipe. - endoscopic instrument maintenance carried out badly (reduction in channel diameter different from the original). - set parameters incorrect. - endoscope code insertion different from that attributed. 	<ul style="list-style-type: none"> - verify openness of the channel and the connection pipe. - check and/or replace the pressure sensor. - check that the pipe is correctly positioned inside the drum and the connector. - check that the set maximum pressure parameters are correct. - check that the code recalled for the instruments matches the inserted instrument. - as a final analysis have the instrument checked by an authorised technical assistance. 	X in part	X in part	X
129 CHA.4 SET 1 OBSTRUCTED PR.OFF	During the cycle an obstruction was found in the endoscopic channel connected to channel 4 instrument 1 with ON-OFF function	<ul style="list-style-type: none"> - organic material or of a different nature obstructing the endoscopic channel of the instrument or the connection pipe to the instrument. - channel 4 instrument 1 pressure sensor faulty. - incorrect connector connection or bent connector pipe. - endoscopic instrument maintenance carried out badly (reduction in channel diameter different from the original). - set parameters incorrect. - endoscope code insertion different from that attributed. 	<ul style="list-style-type: none"> - verify openness of the channel and the connection pipe. - check and/or replace the pressure sensor. - check that the pipe is correctly positioned inside the drum and the connector. - check that the set maximum pressure parameters are correct. - check that the code recalled for the instruments matches the inserted instrument. - as a final analysis have the instrument checked by an authorised technical assistance. 	X in part	X in part	X

HAKKO ALARM MESSAGE	ALARM DESCRIPTION	POSSIBLE CAUSES	SOLUTION	OPER.	SUPERV.	MANUF.
130 CHA.3 SET 2 OBSTRUCTED PR.OFF	During the cycle an obstruction was found in the endoscopic channel connected to channel 3 instrument 2 with ON-OFF function	<ul style="list-style-type: none"> - organic material or of a different nature obstructing the endoscopic channel of the instrument or the connection pipe to the instrument. - channel 3 instrument 2 pressure sensor faulty. - incorrect connector connection or bent connector pipe. - endoscopic instrument maintenance carried out badly (reduction in channel diameter different from the original). - set parameters incorrect. - endoscope code insertion different from that attributed. 	<ul style="list-style-type: none"> - verify openness of the channel and the connection pipe. - check and/or replace the pressure sensor. - check that the pipe is correctly positioned inside the drum and the connector. - check that the set maximum pressure parameters are correct. - check that the code recalled for the instruments matches the inserted instrument. - as a final analysis have the instrument checked by an authorised technical assistance. 	X in part	X in part	X
131 CHA.4 SET 2 OBSTRUCTED PR.OFF	During the cycle an obstruction was found in the endoscopic channel connected to channel 4 instrument 2 with ON-OFF function	<ul style="list-style-type: none"> - organic material or of a different nature obstructing the endoscopic channel of the instrument or the connection pipe to the instrument. - channel 4 instrument 2 pressure sensor faulty. - incorrect connector connection or bent connector pipe. - endoscopic instrument maintenance carried out badly (reduction in channel diameter different from the original). - set parameters incorrect. - endoscope code insertion different from that attributed. 	<ul style="list-style-type: none"> - verify openness of the channel and the connection pipe. - check and/or replace the pressure sensor. - check that the pipe is correctly positioned inside the drum and the connector. - check that the set maximum pressure parameters are correct. - check that the code recalled for the instruments matches the inserted instrument. - as a final analysis have the instrument checked by an authorised technical assistance. 	X in part	X in part	X

HAKKO ALARM MESSAGE	ALARM DESCRIPTION	POSSIBLE CAUSES	SOLUTION	OPER.	SUPERV.	MANUF.
132 CHEM.1 DISPARITY	During chemical 1 extraction phase the difference between the two control and recording flow meters has exceeded the maximum set value.	- flow meters faulty. - no chemical in canister.	- clean and/or replace both flow meters then repeat the calibration procedure. - check that the quantity of chemical in the canister is sufficient (min 150 ml).			X
133 CHEM.2 DISPARITY	During chemical 2 extraction phase the difference between the two control and recording flow meters has exceeded the maximum set value.	- flow meters faulty. - no chemical in canister.	- clean and/or replace both flow meters then repeat the calibration procedure. - check that the quantity of chemical in the canister is sufficient (min 150 ml).			X
134 CHEM.3 DISPARITY	During chemical 3 extraction phase the difference between the two control and recording flow meters has exceeded the maximum set value.	- flow meters faulty. - no chemical in canister.	- clean and/or replace both flow meters then repeat the calibration procedure. - check that the quantity of chemical in the canister is sufficient (min 150 ml).			X
135 CHEM.4 DISPARITY	During chemical 4 extraction phase the difference between the two control and recording flow meters has exceeded the maximum set value.	- flow meters faulty. - no chemical in canister.	- clean and/or replace both flow meters then repeat the calibration procedure. - check that the quantity of chemical in the canister is sufficient (min 150 ml).			X
136 WATER 1 DISPARITY	During water loading phase the difference between the two control and recording flow meters has exceeded the maximum set value.	- flow meters faulty. - high flow meter temperature	- clean and/or replace both flow meters then repeat the calibration procedure. - wait for the flow meters to cool - in the case of cycle after thermo disinfection at 90°C.			X

HAKKO ALARM MESSAGE	ALARM DESCRIPTION	POSSIBLE CAUSES	SOLUTION	OPER.	SUPERV.	MANUF.
137 CONDUCTIVITY CHECK FAILED	During the last rinse phase, in machines with water quality control, the maximum number of automatic rinses has been exceeded.	- water quality lower than that set for the final rinse. - water quality control conduct meter faulty.	- check that the water entering the machine is of the quality desired. - check the settings of the parameters linked to machine quality. - check and/or replace the conduct meter.			X
138 WATER 2 DISPARITY	During water loading phase the difference between the two control and recording flow meters has exceeded the maximum set value.	- flow meters faulty. - high flow meter temperature	- clean and/or replace both flow meters then repeat the calibration procedure. - wait for the flow meters to cool - in the case of cycle after thermo disinfection at 90°C.			X
139 TANK LEVEL FAILURES	The capacitive sensor doesn't read the water level during the water loading phase when it is reached the first 8 liters (heating element protection).	- capacitive sensor of water level failure.	- calibrate the capacitive sensor of washing chamber level. - check and/or replace the capacitive sensor of washing chamber level.		X	X
140 TEMP.CHECK SENS.CHAMBER FAILURE	Incorrect temperature reading in the washing chamber	- washing chamber PT1000 faulty. - PLC reader card faulty.	- check and/or replace the tank temperature probe. - check and/or replace the temperature probe reader card.			X
141 CHAMBER TEMP. INCONGRUITY	Failure on the PT1000 probe reading - the difference between the two PT1000 probe is upper than 2°C	- PT1000 chamber probe failure. - PLC reading board failure.	- check and/or replace the tank temperature probe. - check and/or replace the temperature probe reader card.			X
142 HEATING WITH PUMP OFF ?	Error on the phase programming.		- check the phases programming and correct the washing pump parameter (set ON).			X
144 PLC REC. FAILURES	It is impossible to record the parameters of the cycle	- Recording PLC failure.	- replace the recording PLC.			X

HAKKO ALARM MESSAGE	ALARM DESCRIPTION	POSSIBLE CAUSES	SOLUTION	OPER.	SUPERV.	MANUF.
145 CHANGE TANK CHEMICAL 1	Only with RFID active - disinfectant tank empty		- replace the disinfectant tank	X	X	X
146 CHANGE TANK CHEMICAL 2	Only with RFID active - detergent tank empty		- replace the detergent tank	X	X	X
147 CHANGE TANK CHEMICAL 3	Only with RFID active - chemical 3 tank empty.		- replace the chemical 3 tank	X	X	X
148 CHANGE TANK CHEMICAL 4	Only with RFID active - chemical 4 tank empty.		- replace the chemical 4 tank	X	X	X
149 HAKKO TERMINAL NOT ACTIVE	It is visualized during the PLC programming or with the HAKKO terminal failure	- PLC programming failure. - Terminal failure. - Entry in visualization mode after insertion new HAKKO parameters.	- switch on and switch off the machine. - program again the terminal. - replace the terminal - reset the alarm	X	X	X
150 LOW PRESS. COLLECTOR SET 1	During the cycle the pressure of collector set 1 is below the set value.	- electronic pressure sensor failure. - mechanical pressure sensor failure. - washing pump failure - PLC card faulty.	- check and/or replace the pressure sensor. - check and/or replace the pressure sensor. - check and/or replace the washing pump. - check and/or replace sensor control card/s.	X in part	X in part	X
151 LOW PRESS. COLLECTOR SET 2	During the cycle the pressure of collector set 2 is below the set value.	- electronic pressure sensor failure. - mechanical pressure sensor failure. - washing pump failure - PLC card faulty.	- check and/or replace the pressure sensor. - check and/or replace the pressure sensor. - check and/or replace the washing pump. - check and/or replace sensor control card/s.	X in part	X in part	X

HAKKO ALARM MESSAGE	ALARM DESCRIPTION	POSSIBLE CAUSES	SOLUTION	OPER.	SUPERV.	MANUF.
152 LOW PRESS. COLLECTOR SET 3	During the cycle the pressure of collector set 3 is below the set value.	<ul style="list-style-type: none"> - electronic pressure sensor failure. - mechanical pressure sensor failure. - washing pump failure - PLC card faulty. 	<ul style="list-style-type: none"> - check and/or replace the pressure sensor. - check and/or replace the pressure sensor. - check and/or replace the washing pump. - check and/or replace sensor control card/s. 	X in part	X in part	X
153 HIGH PRESS. COLLECTOR SET 1	During the cycle the pressure of collector set 1 is over the set value.	<ul style="list-style-type: none"> - electronic pressure sensor failure. - PLC card faulty. 	<ul style="list-style-type: none"> - check and/or replace the pressure sensor. - check and/or replace sensor control card/s. 	X in part	X in part	X
154 HIGH PRESS. COLLECTOR SET 2	During the cycle the pressure of collector set 1 is below the set value.	<ul style="list-style-type: none"> - electronic pressure sensor failure. - PLC card faulty. 	<ul style="list-style-type: none"> - check and/or replace the pressure sensor. - check and/or replace sensor control card/s. 	X in part	X in part	X
155 HIGH PRESS. COLLECTOR SET 3	During the cycle the pressure of collector set 1 is below the set value.	<ul style="list-style-type: none"> - electronic pressure sensor failure. - PLC card faulty. 	<ul style="list-style-type: none"> - check and/or replace the pressure sensor. - check and/or replace sensor control card/s. 	X in part	X in part	X
156 FAILURE COLLECTOR PRESS.SWITCH SET 1	During the startup machine, the system has detected a failure on the reading of electronic pressure switch.	<ul style="list-style-type: none"> - electronic pressure sensor failure. - PLC card faulty. 	<ul style="list-style-type: none"> - check and/or replace the pressure sensor. - check and/or replace sensor control card/s. 	X in part	X in part	X
157 FAILURE COLLECTOR PRESS.SWITCH SET 2	During the startup machine, the system has detected a failure on the reading of electronic pressure switch.	<ul style="list-style-type: none"> - electronic pressure sensor failure. - PLC card faulty. 	<ul style="list-style-type: none"> - check and/or replace the pressure sensor. - check and/or replace sensor control card/s. 	X in part	X in part	X

HAKKO ALARM MESSAGE	ALARM DESCRIPTION	POSSIBLE CAUSES	SOLUTION	OPER.	SUPERV.	MANUF.
158 FAILURE COLLECTOR PRESS.SWITCH SET 3	During the startup machine, the system has detected a failure on the reading of electronic pressure switch.	<ul style="list-style-type: none"> - electronic pressure sensor failure. - PLC card faulty. 	<ul style="list-style-type: none"> - check and/or replace the pressure sensor. - check and/or replace sensor control card/s. 	X in part	X in part	X
160 INCONGRUITY LEAK TEST CAP 1	When the control is active, the instrument presence sensor is active with the endoscope in the position 1 or is not active without instrument on position 1.	<ul style="list-style-type: none"> - sensor failure - wrong connection of operator - wrong insertion of operator on touch-screen. 	<ul style="list-style-type: none"> - replace or calibrate the sensor - check the correct connection of endoscope 	X in part	X	X
161 INCONGRUITY LEAK TEST CAP 2	When the control is activated, the instrument presence sensor is active with the endoscope in the position 2.	<ul style="list-style-type: none"> - sensor failure - wrong connection of operator - wrong insertion of operator on touch-screen. 	<ul style="list-style-type: none"> - replace or calibrate the sensor - check the correct connection of endoscope 	X in part	X	X
162 FAILURE ON LT PUMP	During the leak test the pressure set hasn't been reached.	<ul style="list-style-type: none"> - air pump for the leak test failure. - leak on the leak test circuit. - endoscope basket reversed. - endoscope connection lack. - oring of the basket locking system broken (on the chamber). - leak test pipe broken. 	<ul style="list-style-type: none"> - leak test pump replacement. - check and restore the leak test circuit. - check the endoscope basket position (connection blocks on the left side of the loading side). - check the oring integrity on the basket connection block inside the chamber. - check the instrument connection pipe integrity (near the metallic clamp). 	X in part	X in part	X
163 REFILL ALARM LT SET 2	The system has exceeded the number of refill leak test set by parameter.	<ul style="list-style-type: none"> - problem on leak test instrument. - leak from idraulic circuit of leak test. - wrong value of parameter. 	<ul style="list-style-type: none"> - check the instrument leak test. - check the o-ring and connection of leak test. - check the pipe connection. - check the value parameter. 		X	X

HAKKO ALARM MESSAGE	ALARM DESCRIPTION	POSSIBLE CAUSES	SOLUTION	OPER.	SUPERV.	MANUF.
164 REFILL ALARM LT SET 3	The system has exceeded the number of refill leak test set by parameter.	- problem on leak test instrument. - leak from idraulic circuit of leak test. - wrong value of parameter.	- check the instrument leak test. - check the o-ring and connection of leak test. - check the pipe connection. - check the value parameter.		X	X
165 FAILURE LS LOCKING/ UNLOCKING	Failure limitswitch locking/unlocking 53SQ25/53SQ25A/53SQ26/ 53SQ26A	-Limitswitch not fed or damaged	- Replace the limitswitch - Check the electrical circuit		X	X
166 FAILURE LOCKING/ UNLOCKING	Failure locking/unlocking;	Pressure regulator on pilot valves group is not calibrated.	-Check the pressure regulator of piston - Adjust pressure to 4 bar.		X	X
167 LOADING DOOR LS DISAPRITY	Loading door limitswitch disparity;	- Electrical contact; - Both limitswitches are intercept.	- Check the micro;		X	X
168 UNLOADING DOOR LS DISPARITY	Unloading door limitswitch disparity;	- Electrical contact; - Both limitswitches are intercept.	- Check the micro;		X	X
WARNINGS						
176 PLC LOW BATTERY			- replace buffer battery.			X
177 DISPLAY LOW BATTERY			- replace buffer battery.			X
178 ASKING MAINTENANCE			- call technical assistance for ordinary maintenance.	X	X	X

HAKKO ALARM MESSAGE	ALARM DESCRIPTION	POSSIBLE CAUSES	SOLUTION	OPER.	SUPERV.	MANUF.
179 'HEPA' FILTER OBSTRUCTED			- replace the chamber filter.			X
180 UNLOD. SIDE TERMINAL FAIL.			- check and/or replace the unload.side terminal in the case of passing machine.			X
181 PROBLEM COMMUNICATION WITH RFID	During the cycle start or during the washing cycle the RFID control system has stopped to communicate with the PLC.	- RFID control unit failure. - PLC connection failure. - RFID antenna failure.	- check and/or replace the reading RFID antenna. - check and/or replace the RFID antenna. - check the connection between the RFID control unit and the PLC.			X
182 PROBLEM READ RFID CH.1	During the cycle start the disinfectant RFID antenna has stopped to communicate with the PLC.	- RFID control unit failure. - PLC connection failure. - RFID antenna failure.	- check and/or replace the reading RFID antenna of the disinfectant or try to replace the chemical tank (with the Steelco original RFID). - check and/or replace the RFID antenna. - check the connection between the RFID control unit and the PLC.			X
183 PROBLEM READ RFID CH. 2	During the cycle start the detergent RFID antenna has stopped to communicate with the PLC.	- RFID control unit failure. - PLC connection failure. - RFID antenna failure.	- check and/or replace the reading RFID antenna of the detergent or try to replace the chemical tank (with the Steelco original RFID). - check and/or replace the RFID antenna. - check the connection between the RFID control unit and the PLC.			X

HAKKO ALARM MESSAGE	ALARM DESCRIPTION	POSSIBLE CAUSES	SOLUTION	OPER.	SUPERV.	MANUF.
184 PROBLEM READ RFID CH. 3 N.C.	During the cycle start the chemical 3 RFID antenna has stopped to communicate with the PLC.	<ul style="list-style-type: none"> - RFID control unit failure. - PLC connection failure. - RFID antenna failure. 	<ul style="list-style-type: none"> - check and/or replace the reading RFID antenna of the chemical 3 or try to replace the chemical tank (with the Steelco original RFID). - check and/or replace the RFID antenna. - check the connection between the RFID control unit and the PLC. 			X
185 PROBLEM READ RFID CH. 4 N.C.	During the cycle start the chemical 4 RFID antenna has stopped to communicate with the PLC.	<ul style="list-style-type: none"> - RFID control unit failure. - PLC connection failure. - RFID antenna failure. 	<ul style="list-style-type: none"> - check and/or replace the reading RFID antenna of the chemical 4 or try to replace the chemical tank (with the Steelco original RFID). - check and/or replace the RFID antenna. - check the connection between the RFID control unit and the PLC. 			X
187 FAILURE ON WATER FILLING (TIME)	During one of the water loading phases the time limit to reach the water quantity (12 lt) has been exceeded	<ul style="list-style-type: none"> - water inlet tap closed. - water filter obstructed. - no pressure on the hydraulic circuit (1 bar minimum). - pneumatic valve or pilot valve failure. - PLC command board failure (see electrical scheme). 	<ul style="list-style-type: none"> - check if the water inlet tap is open. - check if there is pressure on the external hydraulic circuit. - check the functioning of the water loading pump inside the machine under the break tank. - check the water loading pneumatic valve and the pilot valve. - check the water filter. - check the PLC control board. 			X
188 LOW LEVEL/ NOT OK CHEM. 1	Indicates that 3 cycles remain to the end of the disinfectant chemical		- replace the disinfectant chemical tank (chemical 1)	X		
189 LOW LEVEL/ NOT OK CHEM. 2	Indicates that 3 cycles remain to the end of the detergent chemical		- replace the detergent chemical tank (chemical 2)	X		

HAKKO ALARM MESSAGE	ALARM DESCRIPTION	POSSIBLE CAUSES	SOLUTION	OPER.	SUPERV.	MANUF.
190 LOW LEVEL/ NOT OK CHEM. 3	Indicates that 3 cycles remain to the end of the chemical 3		- replace the chemical tank (chemical 3)	X		
191 LOW LEVEL/ NOT OK CHEM. 4	Indicates that 3 cycles remain to the end of the chemical 4		- replace the chemical tank (chemical 4)	X		

9. DEMOLITION AND DISPOSAL

For a correct disposal of the machine follow the next indications:

- Do not dispose these machines as solid waste but make a separated collection.
- The reuse or the correct recycling of the Electrical and Electro-mechanics equipment (AEE) is useful for the environment preservation and the human health.
- According to the European Directive WEEE 2012/19/EC specific collection centre are available; it is possible to deliver this electrical equipment to this centre, and it is possible to return the equipment to the Distributor when a new one machine is bought.
- The public administration and the AEE manufacturer are committed to favour the reuse and the reclamation process of the RAEE (Electrical and electro-mechanics equipment waste) through the organization of the refuse collection activity and through the use of opportune planning solution.
- **The law penalizes with opportune sanctions who illegally dispose the RAEE.**

ATTENTION: PLEASE CONSULT ANNEX C IN THIS MANUAL.

10. QUALIFICATION

10.1 Installation qualification (IQ)

Provided on request

10.2 Operative qualification (OQ)

Provided on request

10.3 Performance qualification (PQ)

As specified in Attachment A.3 of Standard ISO 15883:4 2009, from the moment in which the EW2 is installed upon the final site of use, the responsibility for guaranteeing that the equipment has been correctly installed and is fully operational falls on the purchaser/user.

This includes:

- Installation check and tests;
- Operational tests;
- Operational tests;
- Periodic tests;
- The use of process chemicals recommended by the manufacturer;
- The use of the EW2 in accordance with the manufacturer's instructions (limiting the re-conditionable devices in the EW2 to those specified by the manufacturer).

NOTE:



Certificate N° 632

Certificate of Participation

We certify that Mr XXXXXXXX of the company YYYYYYYY has attended the training course for

EW2

Riese Pio X, 03/09/2014

Person in charge for training



Steelco S.p.A.

Via Balegante, 27 - 31039 - Riese Pio X (TV) - Italy
Tel. +39 0423.7561 Fax +39 0423.755528
Website: www.steelcospa.com



"For the Environmentally conscious"

M/D 15410 Rev/00

ANNEX A – TRAINING CERTIFICATE

ANNEX B – WATER SAMPLING DURING THE FINAL RINSING PHASE

Annex B provides both the instructions and the methods to take the microbiological sample by using the Steelco - Q water BSK (Professional Sampling Kit for Bacterial Check) as well as the relative key for the decoding and the reading of the results obtained.

In any case, please refer to current Legislation, National Guidelines and/or internal protocols.



Q water BSK
Professional Sampling Kit for Bacterial Check
(code 99911268)

Endoscopes can be re-processed in the cycle dedicated to biological sampling. The only difference compared to a normal disinfection cycle refers to the interruptions during the final rinsing phase.

Water samples are taken during the final rinsing stage following the disinfection stage. The final rinsing cycle consists of two stages. The sample must be taken during the final rinsing stage.

It is possible to take a water sample from the washing chamber by carrying out the following procedure:

- Set the parameter **CYCLE STOP ENABL.** to **YES**.
- Note: at the end of the water sample-taking cycle, restore the value to **NO**.

ALARM	CONFIG, MANUT, DATA	05/09/14 09:59
DATA CONFIG.	TIMES CONFIG. 1	TIMES CONFIG. 2
DATA VARIOUS1	DATA VARIOUS2	DATA CYCLE
User:		
Drain v. out of cycle:	CLOSED	
Contem. door open.:	NO	
Cycle stop enabl.:	YES	
Autom. doors lock.:	NO	
Automatic start cycle:	NO	
Must unload basket:	NO	
Password:	*****	
SAVE DATA	PRINT DATA	

- Check if it is activate the **STOP END = YES** on the selected program for the water sampling and start the program.

PROGRAMS MANAG.	023	05/09/14 14:36
Description:	CAMPIONATURA	
Door: OK	UNLOAD.	NOT OK LOAD.
Program type:	ENDOSCOPES	
RISCIACQUO	STOP END=YES	
Water	WATER	I 12.0 Pumps YES
Chem.		% 00.00
Chem.		% 00.00
Temp. oC	00.0	Maint. oC NO
Mix. T. s	000	T. Phase s 0060
CONFIRM	CHANGE PHASE	CANCEL

- When the machine displays the message shown on the following picture, open the door of the washing chamber and pick up the water sampling from the sump by using the Steelco - Q water BSK (Professional Sampling Kit for Bacterial Check). Be sure to perform the sampling in an aseptic way.



- Close the door and press **CONFIRM** button to continue the washing program.



	<h2 style="text-align: left; margin: 0;">ATTENTION</h2>
	<ul style="list-style-type: none"> • Adequate measures must be implemented to avoid contamination of the sample during the water sample-taking stage. It is recommended to use the Steelco - Q water BSK (Professional Sampling Kit for Bacterial Check). • The water samples for the microbiological test must be taken only during the final rinsing stage. Samples must not be taken during other stages of the process. • Correct, periodic maintenance of the equipment prevents the risk of contamination. Follow the manufacturer's instructions as regards the replacement of bacteriological filters as well as any pre-filters. • It is important to schedule appropriate thermal disinfection and chemical self-disinfection cycles in accordance with the manufacturer's instructions and internal protocols.

SAMPLE TAKING

In order to take water samples during the final rinsing stage use the Steelco - Q water BSK (Professional Sampling Kit for Bacterial Check - code 99911268) and follow the instructions below:

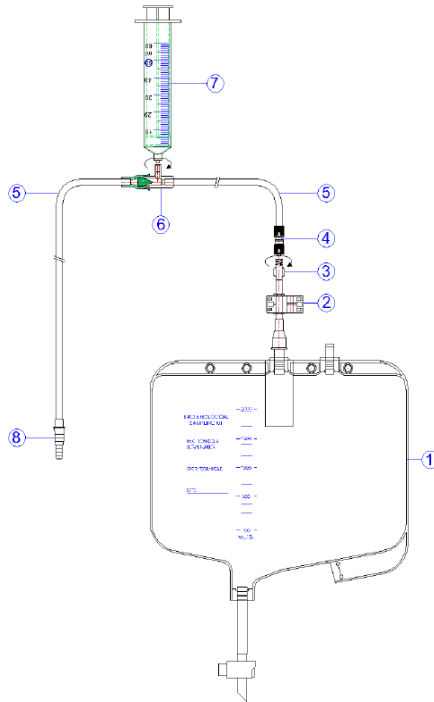

1. Insert the 80 cm PVC pipe **(5)** into the sump of the washing chamber;
2. Suck the water from the washing chamber using the 60 ml syringe **(7)**;
3. Push the plunger of the syringe **(7)** to drain the water into the collection bag for biological fluids **(1)**;
4. Disconnect the collection bag for biological fluids **(3)** from the Kit and hand it to the microbiology laboratory quickly.
5. Compile the fields on the bag with the appropriate information:
 - Model and serial number of the machine;
 - Name and ID of the operator (that takes the water sampling);
 - Date.

REPROCESSING CYCLE EFFECTIVENESS TEST CARRIED OUT IN THE SUCTION CHANNEL

It is also possible to test the effectiveness of the entire re-conditioning cycle of the endoscope suction channel in the following way:

- Put 20 ml of sterile water in the suction channel (by using a sterile syringe) collecting it from a sterile container situated at the distal part of the tool;
- Clean the same channel using a special cleaning brush by cutting it directly inside the sterile water container.
WARNING: the cleaning brush **MUST** be sterile.
- Remember to close all air and water channel valves before carrying out this procedure.
- Every single container must be accompanied not only by the request form but also by the endoscope type and serial number, the type of channel on which the brushing has been carried out, the name of the operator performing the sampling procedure as well as the report relating to the re-conditioning cycle carried out.

INTERPRETATION OF THE RESULTS

As for the interpretation of the results, please refer to the following table and criteria.

NUMBER OF COLONIES/100 ml	INTERPRETATION	ACTION
0	SATISFACTORY	-----
1-9 (carried out on a regular basis)	ACCEPTABLE	Count under reasonable control
10-100	UNSATISFACTORY	Investigate by implementing opportune thermal disinfection and chemical self-disinfection cycles.
>100	UNACCEPTABLE	Stop the endoscope washer. Start two thermal disinfection and two chemical self-disinfection cycles. Repeat the test of control and take necessary actions as regards decontamination.

After interpreting the results, take opportune measures in accordance with the 2 attached tables.

NUMBER OF COLONIES (NOT PSEUDOMONAS)		
TVC LEVEL	ACTION	
SATISFACTORY	< 1cfu/100 ml	<ul style="list-style-type: none"> No action required.
ACCEPTABLE	1 – 9 cfu/100 ml	<ul style="list-style-type: none"> The personnel must have carried out a self-disinfection cycle in the morning in accordance with the instructions provided by the endoscope washer manufacturer as well as internal protocols. The carrying out of a daily self-disinfection cycle.
UNSATISFACTORY	10 – 50 cfu/ ml	<ul style="list-style-type: none"> The personnel must carry out two thermal disinfection cycles (one after another - 80°C for 10 min) and a special chemical disinfection cycles (35°C for 10 min double chemical)
	51 – 100 cfu/ ml	<ul style="list-style-type: none"> The personnel must carry out a special chemical disinfection cycle as well as a thermal disinfection cycle (one after another 80°C for 10 min one after another 55°C for 10 min double chemical). Take another water sample.
UNACCEPTABLE	> 100 cfu/100 ml	<p>STOP USING THE ENDOSCOPE WASHER.</p> <p>The person in charge of the endoscope washer must:</p> <ul style="list-style-type: none"> Carry out a special chemical disinfection cycle (55° double chemical for 10 min). Carry out 2 thermal disinfections cycles (one after another to 90°C for 10 min). Take another water sample. <p>The personnel must:</p> <ul style="list-style-type: none"> Do not use the endoscope washer until it has been confirmed that the water sample has a contamination value of < 100 cfu/100 ml. Continue to carry out a self-disinfection cycle on a daily basis. Carry out a special thermal disinfection cycle on a daily basis. <p>Note: Advice will be obtained from the Lead Doctor for Infection Prevention and Control if there are recurring unacceptable TVC levels.</p>

NUMBER OF COLONIES (PSEUDOMONAS)		
TVC LEVEL	ACTION	
SATISFACTORY	< 1cfu/100 ml	<ul style="list-style-type: none"> No action required.
ACCEPTABLE	1 – 9 cfu/100 ml	<ul style="list-style-type: none"> The personnel must have carried out a self-disinfection cycle in the morning in accordance with the instructions provided by the endoscope washer manufacturer as well as internal protocols. The carrying out of a daily self-disinfection cycle. Do not re-process endoscopes until it has been confirmed that the water sample has a contamination value of < 6 cfu/100 ml.
UNSATISFACTORY	10 – 50 cfu/ ml	<ul style="list-style-type: none"> The personnel must carry out two thermal disinfection cycles (one after another - 80°C for 10 min) and a special chemical disinfection cycles (35°C for 10 min double chemical) Do not re-process endoscopes until it has been confirmed that the water sample has a contamination value of < 6 cfu/100 ml. Do not re-process cystoscopes or bronchoscopes until it has been confirmed that water sample has a contamination value of < 10 cfu/100 ml.
	51 – 100 cfu/ ml	<ul style="list-style-type: none"> The personnel must carry out two special chemical disinfection cycles (55°C for 10 min double chemical) and two thermal disinfection cycle (one after another 80°C for 10 min). Take another water sample. Do not re-process endoscopes until it has been confirmed that the water sample has a contamination value of < 6 cfu/100 ml. Do not re-process cystoscopes or bronchoscopes until it has been confirmed that water sample has a contamination value of < 10 cfu/100 ml. <p>Note: Advice will be obtained from the Lead Doctor for Infection Prevention and Control if there are recurring unacceptable TVC levels.</p>

UNACCEPTABLE	> 100 cfu/100 ml	<p>STOP USING THE ENDOSCOPE WASHER.</p> <p>The person in charge of the endoscope washer must:</p> <ul style="list-style-type: none"> • Change all internal water filters. Carry out 2 special chemical disinfection cycles (55° double chemical for 10 min). • Carry out 2 thermal disinfection cycles (one after another to 90°C for 10 min). • Take another water sample. <p>The personnel must:</p> <ul style="list-style-type: none"> • Do not use the endoscope washer until it has been confirmed that the water sample has a contamination value of < 100 cfu/100 ml. • Continue to carry out the thermal disinfection cycle on a daily basis. • Carry out a chemical self-disinfection cycle on a daily basis. • Do not re-process endoscopes until it has been confirmed that the water sample has a contamination value of < 6 cfu/100 ml. Do not re-process cystoscopes or bronchoscopes until it has been confirmed that water sample has a contamination value of < 10 cfu/100 ml. <p>Note: Advice will be obtained from the Lead Doctor for Infection Prevention and Control if there are recurring unacceptable TVC levels.</p>
---------------------	----------------------------	--

	ATTENTION
	THE PREVIOUSLY DESCRIBED CYCLES ARE STORED INTO THE MEMORY OF THE MACHINE.

ANNEX C – TEST PROCEDURE WHEN INSTALLING

	ATTENTION
	<p>During the first installation of the equipment upon the site of use, with the aim of eliminating the risk of contamination of the endoscope washer, following maintenance operations that influence critical parts of the endoscope washer (wash pumps, etc.) or after transferring the endoscope washer to another operational centre, the following procedure MUST be carried out:</p> <ul style="list-style-type: none"> • 3 empty cycles carried out using only detergent; • 2 complete cycles with detergent + disinfectant; • 1 thermal disinfection cycle carried out at 80°C.

	ATTENTION
	<p>USE ONLY CHEMICAL PRODUCTS THAT HAVE BEEN TESTED AND APPROVED BY THE MANUFACTURER AND IN USE WITH THIS SYSTEM.</p>

ANNEX D – BARCODE READER SETTING

In case of barcode replacement or memory loss, set the barcode reader by reading the following codes.



**RS-232 Serial Interface
Quick Set Command**

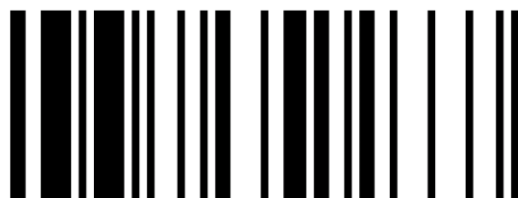

PROGRAM

Host Interface Selection



for **Gold/Jade/Diamond** series



1

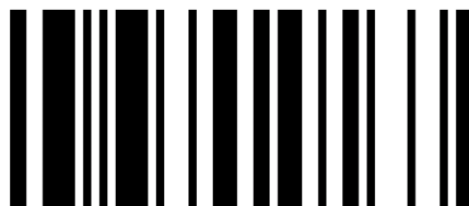

END (Exit)

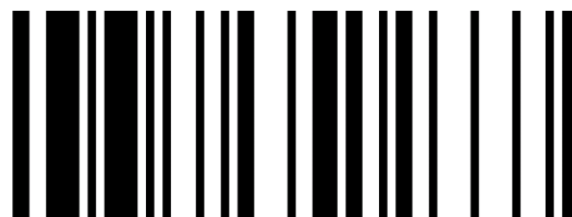

PROGRAM

Record Suffix

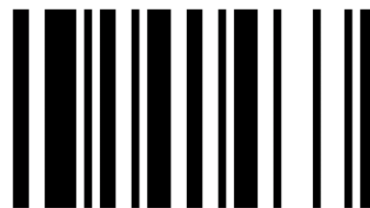
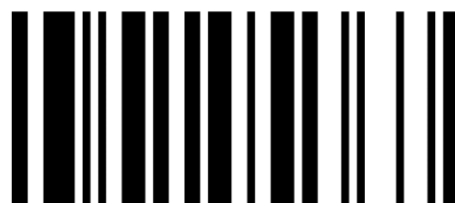

3



END (Exit)

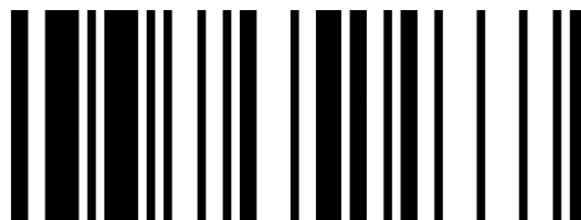

PROGRAM

Baud Rate (BPS)



1

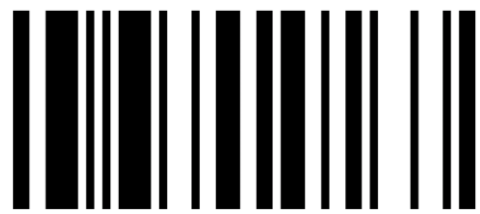

END (Exit)

ANNEX E: SPECIFICATION OF ROUTER NAT PROGRAMMING

1. SOFTWARE GUIDE USE

1.1 New manufacturing router configuration

To set the router, it is necessary to connect it by using an Ethernet cable with one numbered door of the router (please do not connect it to the door signed by Internet).

When the led, which is situated on the upper side of the router corresponding to the door to which the Ethernet cable has been connected, is on, it is possible to start up the software for the configuration.

Set the IP address of your PC to **192.168.88.222** (network mask 255.255.255.0).

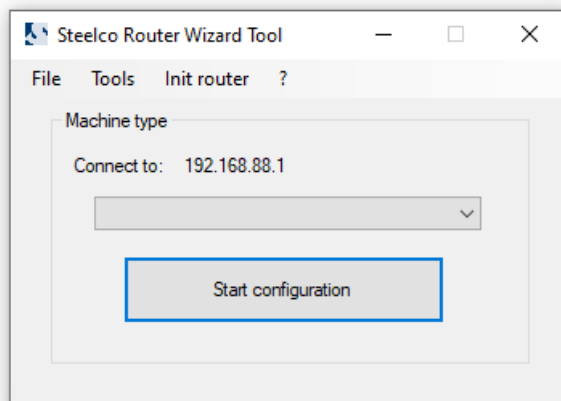

From the dropdown menu, which is situated in the middle, it is possible to select the machine type for which you should set the router. From the file → settings submenu, set the IP address and the access credentials as indicated in the picture below on the right and here below:

IP: **192.168.88.1**
 Default username: **admin**
 Default password: **(empty)**

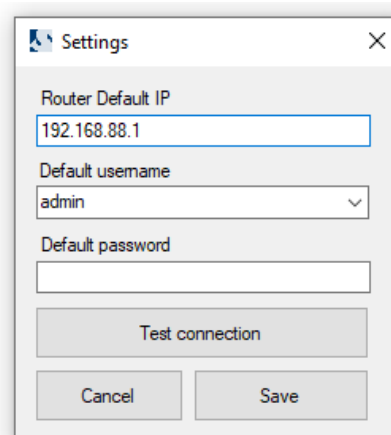
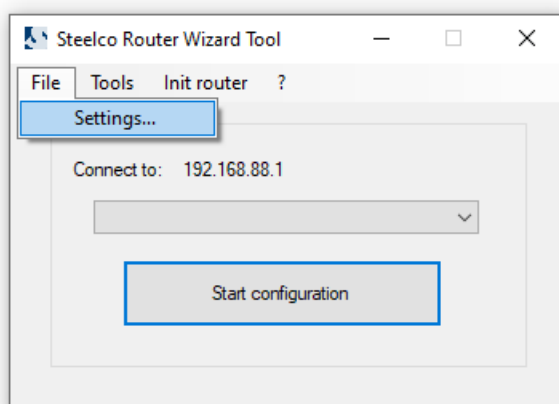

Once the fields have been set, press *Test connection* key, in order to verify the connection of the router. If the connection is correctly set, a message will appear with the following text: *Test successfull*.

When the configurations have been correctly set, press the *Start configuration* key, in order to start the router programming. The PC will try to connect to the router in this way and a similar window will appear until the connection has not been established yet.

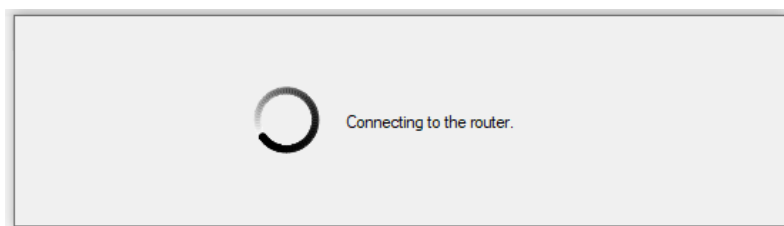

When the connection has been established, in the following window it is possible to set all data related to the machine configuration.

In case a single type machine is selected (ED200, EW2, EW1 S) a window will appear, which will allow to add all the data related to the network connection of a single machine.

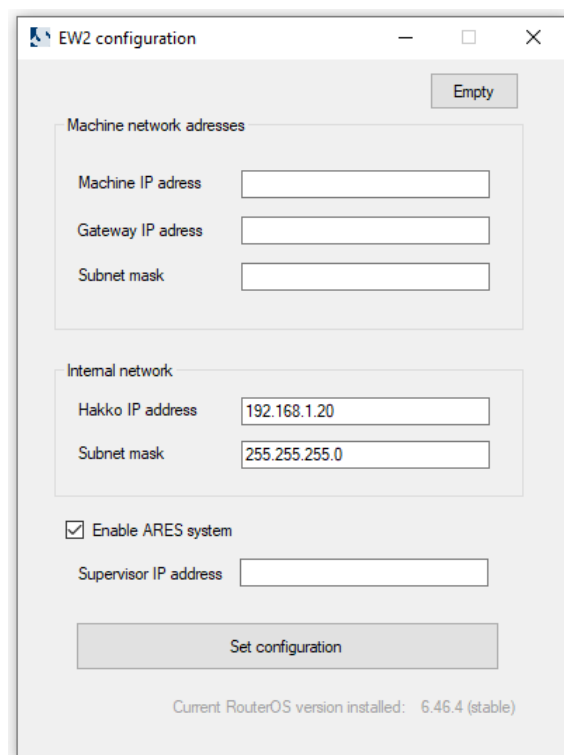

In this window it is necessary to insert all the data to be associated to the machine: *Machine IP address*, *Gateway IP address* e *Subnet mask*. Just in case the machine must be connected to the ARES traceability system, the relative field must be enabled and the IP address field of the PC, in which the traceability system is installed, must be filled.

The previous data should be provided by IT responsible of the installation, where the machines must be installed.

Hakko IP address and *Subnet mask* fields must not be modified if it is not required. The default values are always filled and they have to be the ones indicated here below:

Hakko IP address: **192.168.1.20**
 Subnet mask: **255.255.255.0**

In case a double type machine is selected (EW1 S in rack version) a window will appear, in which it will be possible to insert the data related to the network connection of two machines.

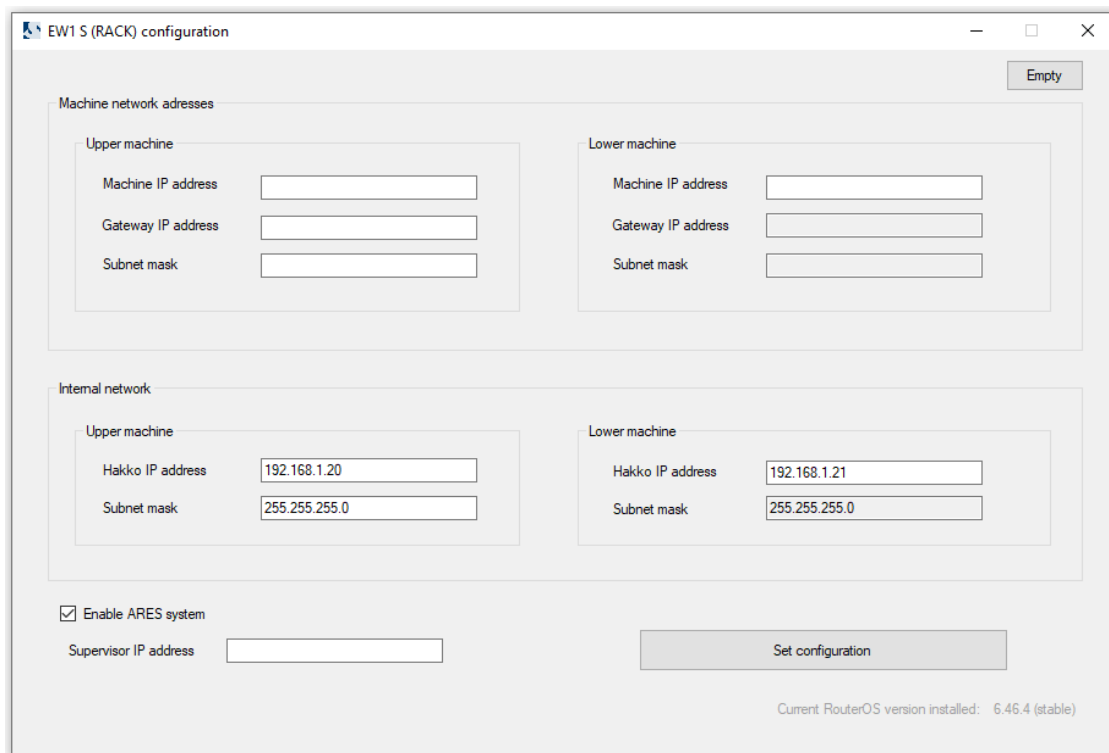

On the left side it is necessary to insert the data related to the machine on the upper side of the rack (IP address, gateway address and network mask). On the right side, similar data are requested for the machine on the lower side of the rack.

In case the machine must be connected to ARES system, and only in this case, it is necessary to flag the field on the left lower side. In this case it is necessary to add the IP address corresponding to the PC on which the traceability system will be installed.

The previous data must be provided by the IT installation responsible, in which the machines are installed.

Hakko IP address and *Subnet mask* fields are still filled and they must not be modified if not in case on a specific request. The default values are indicated here below:

Upper machine:

Hakko IP address: **192.168.1.20**
 Subnet mask: **255.255.255.0**

Lower machine:

Hakko IP address: **192.168.1.21**
 Subnet mask: **255.255.255.0**

When all the fields are correctly filled, press the *Set configuration* key. In this way the information will be saved on the router. It will start after this operation and it is necessary to wait for about 60 seconds, until the process ends. During this operation, the waiting window will appear.

Do not switch off or disconnect the router during this operation.

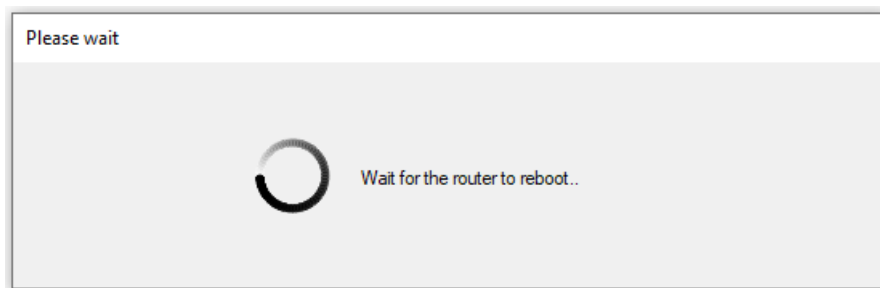

If the operation ends with a positive result, on the display the screen shown below appears with the positive result of the configuration.

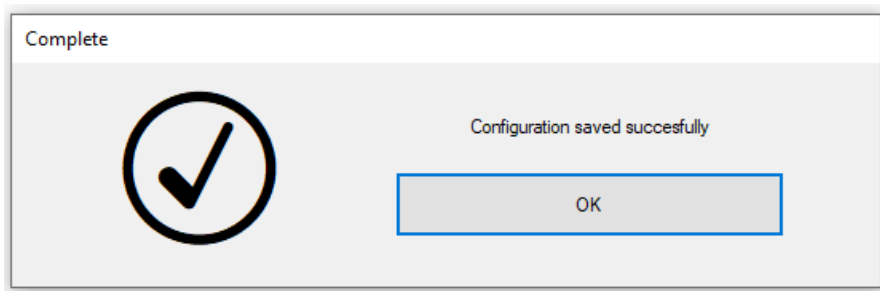

Press ok and close the program.

In this way the configuration will be completed, and it is possible to disconnect the router from the pc and connect it to the machine with the usual conventions:

- **The “blue” door marked by the Internet sign should be connected to the wall plug external from the machine and therefore to the customer network;**
- **The “white” doors numerated from 2 to 5 are used to connect the router to the internal network of the machine.**

1.2 Router reconfiguration still programmed

In case you must reset a router, which has been programmed, the procedure to be followed is the one indicated below. First of all, set the IP address of the pc to **192.168.1.222** (network mask 255.255.255.0). therefore, open the *File* → *settings* menu and set the parameters as follows:

IP: **192.168.1.1**
Default username: **steelco or admin**
Default password: **(to be not modified) the password field is automatically filled**

Once these fields are filled in, press the *Test connection* key to verify if the connection to the router is possible. In positive case, press the *Save* key and go on with the following step. In case the test result is not positive, please have a look at the following chapter, where is indicated how to perform a hard router reset.

If the connection test has been positively performed, go on with the restore of the fabrication router settings. In order to do that, select the *Tools* → *Factory reset* menu, as it is shown in the following picture.

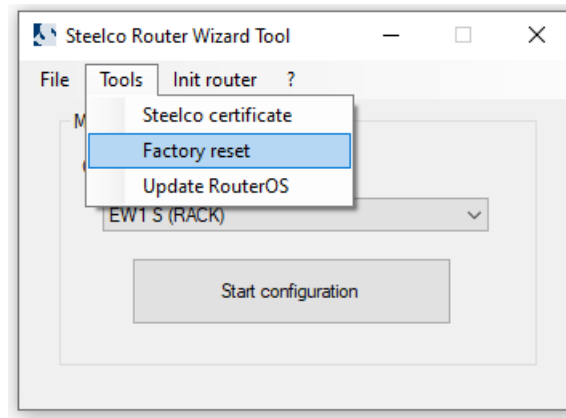

Once this procedure has been completed, change the settings into the *File* → *settings* menu with the

following parameters: IP:**192.168.88.1**

Default username: **admin**

Default password: **(empty)**

Select the machine model and complete the setting as illustrated in the previous paragraph.

1.3 Hard router reset procedure

In case the connection to the router is not possible or for some reasons the setting procedure has not a positive result, it is possible to perform a router hardware reset to restore it to the manufacturing settings.

In order to do that, follow the points indicated below:

- When the router is switched off, press the RES key and keep it pressed on the frontal part of the router (1);
- Supply the router (2) and keep the RES key pressed until the USR led (3) starts to blink and not over (it is important not to keep the key pressed beyond this point for more than 5 seconds).
- Leave the router in standby for 60 seconds.
- At this point the router has come back to its fabrication origins and it is possible to program it by following the procedure indicated on paragraph 2.1.

