

CUSTOMER:	DESCRIPTION:
CIP CHISINAU	PAEDIATRIC PACK FOR USE WITH FX15RW40
MOLDOVA	

PRODUCT CODE:	DRAWING TYPE:	Total Priming Volume:
CX-ML025	PRODUCTION	XXX

DRAWN BY:	ISSUED:	ISSUE No:
SHIRLEY COURTNEY	26/02/2016	6
INT. AMEND:	AMENDED:	SHEET No:
28/03/2019-SF	16/04/2019-SF	1/5

THIS DOCUMENT IS THE PROPERTY OF TERUMO EUROPE AND MAY NOT BE COPIED BY ANY THIRD PARTY.





7.

080249
1/2 x 3/8
080520 PEEL POUCH 100 X 150 MM



8.

080251
3/8 X 3/8
080520 PEEL POUCH 100 X 150 MM

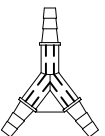

9.

080257
1/4x1/4x1/4
080523 PEEL POUCH 100 X 200 MM

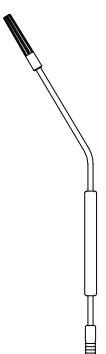

10.

080825
PAEDIATRIC SUCKER
080509 VIEW/REEL 100 mm LENGTH CUT TO - 50cm

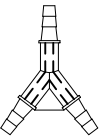

11.

080250
3/8x3/8x3/8
080523 PEEL POUCH 100 X 200 MM

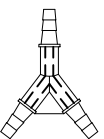

12.

080262
3/8x1/4x3/8
080523 PEEL POUCH 100 X 200 MM

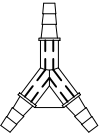

13.

080258
3/8x1/4x1/4
080523 PEEL POUCH 100 X 200 MM



14.

080255
1/4 x 1/4
080520 PEEL POUCH 100 X 150 MM

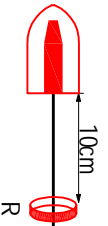

080397
VENTED 9/16
RED CAP

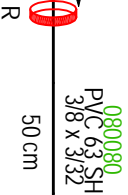

080080
PVC 63 SH
3/8 x 3/32

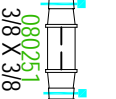

080024
SILICONE
3/8 x 3/32

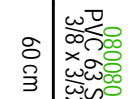

080080
PVC 63 SH
3/8 x 3/32

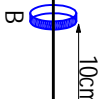

080398
VENTED 9/16
BLUE CAP

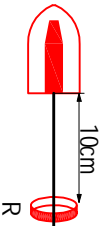

080397
VENTED 9/16
RED CAP

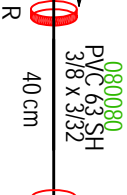

080080
PVC 63 SH
3/8 x 3/32

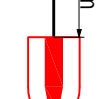

080397
VENTED 9/16
RED CAP

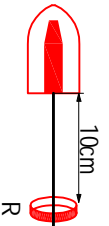

080389
VENTED 3/8
RED CAP

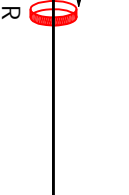

080079
PVC 63 - 65 SH
1/4 x 1/16

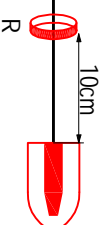

080389
VENTED 3/8
RED CAP

CUSTOMER:

CIP CHISIMAU
MOLDOVA

DESCRIPTION:

PAEDIATRIC PACK FOR USE WITH FX15RW40

PRODUCT CODE:

CK-ML025

DRAWING TYPE:

PRODUCTION

Total Priming Volume:

XXX

DRAWN BY: SHIRLEY COURTNEY

INT. AMEND: 28/03/2019-SF

ISSUED: 26/02/2016

AMENDED: 16/04/2019-SF

ISSUE No: 6

SHEET No: 2/5

THIS DOCUMENT IS THE PROPERTY OF TERUMO EUROPE AND MAY NOT BE COPIED BY ANY THIRD PARTY.



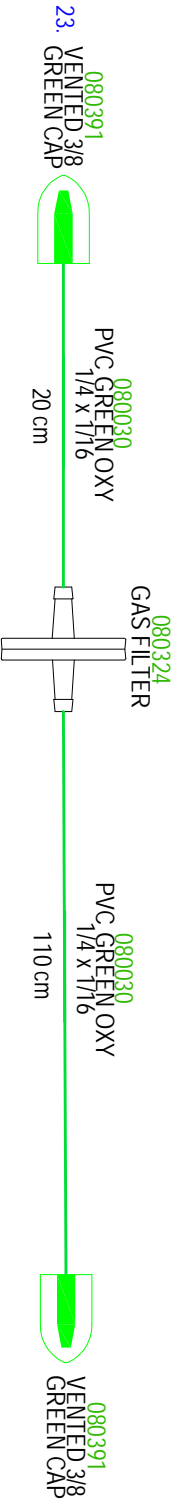
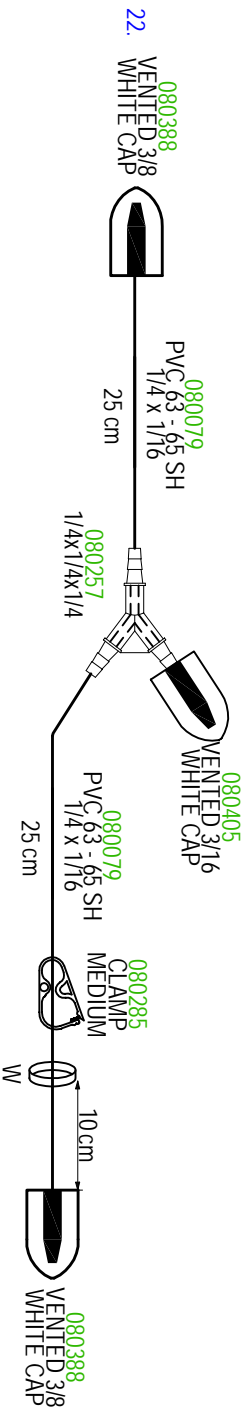
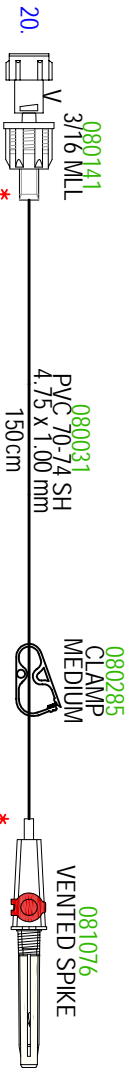
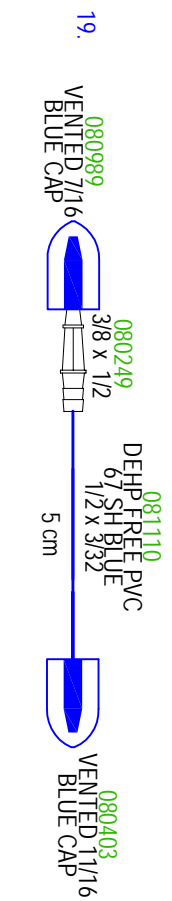
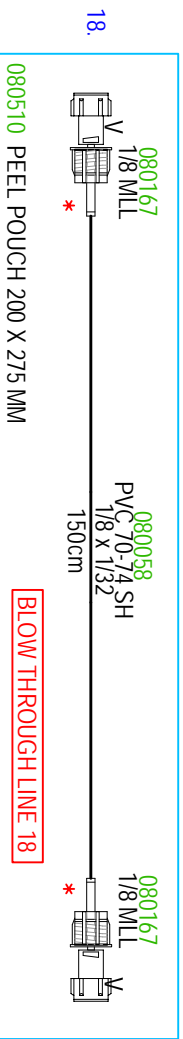

080443 PEEL POUCH 250 X 500 MM

CUSTOMER:	DESCRIPTION:
CIP CHISINAU	PAEDIATRIC PACK FOR USE WITH FX15RW40
MOLDOVA	
PRODUCT CODE:	DRAWING TYPE:
CX-ML025	PRODUCTION
	Total Priming Volume:
	XXX

DRAWN BY:	ISSUED:
SHIRLEY COURTNEY	26/02/2016
INT. AMEND:	AMENDED:
28/03/2019-SF	16/04/2019-SF
THIS DOCUMENT IS THE PROPERTY OF TERUMO EUROPE AND MAY NOT BE COPIED BY ANY THIRD PARTY.	
TERUMO	SHEET No: 3/5
	ISSUE No: 6

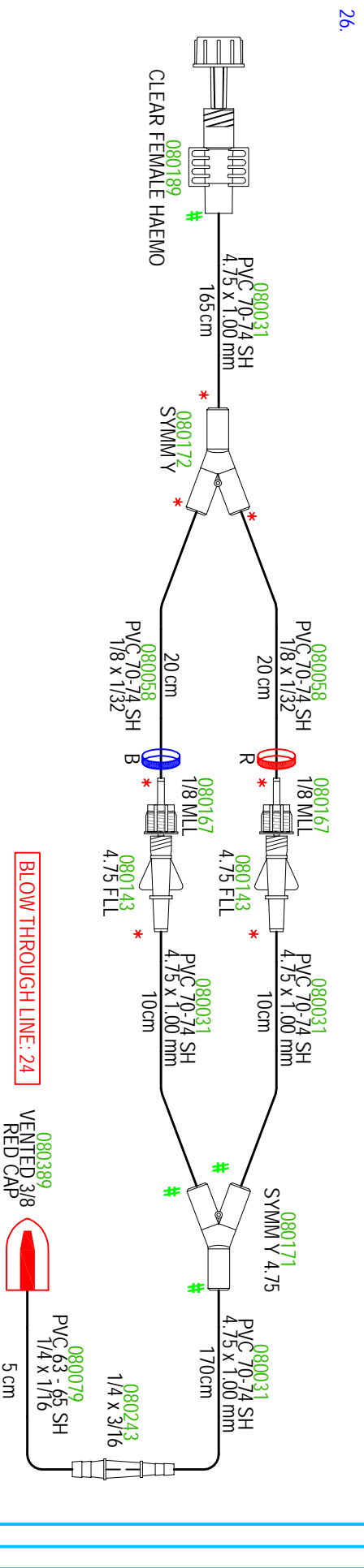
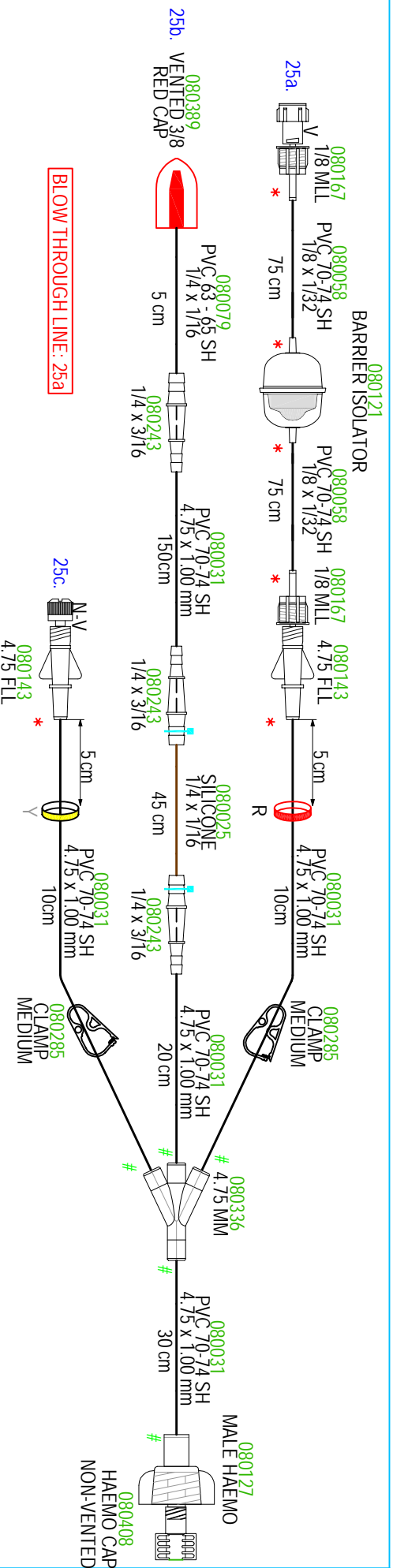

- 080511 PEEL POUCH 250 X 485MM
- 080512 PEEL POUCH 300 X 510MM
- 080483 GAS POUCH 508 X 648 X 165 MM

CUSTOMER:	DESCRIPTION:
CIP CHISINAU	PAEDIATRIC PACK FOR USE WITH FX15RW40
MOLDOVA	
PRODUCT CODE:	DRAWING TYPE:
CX-ML025	PRODUCTION
	Total Priming Volume:
	XXX

DRAWN BY:	ISSUED:
SHIRLEY COURTNEY	26/02/2016
INT. AMEND:	AMENDED:
28/03/2019-SF	16/04/2019-SF
THIS DOCUMENT IS THE PROPERTY OF TERUMO EUROPE AND MAY NOT BE COPIED BY ANY THIRD PARTY.	
SHEET No:	ISSUE No:
4/5	6



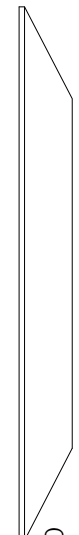

CP LAYER PAD
080856
0,25

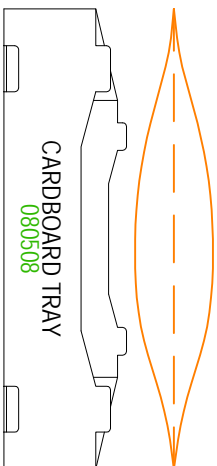
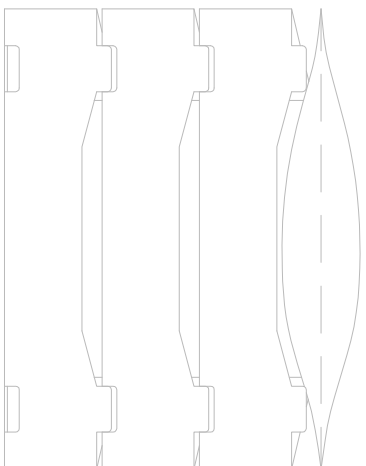

CARDBOARD TRAY
080508

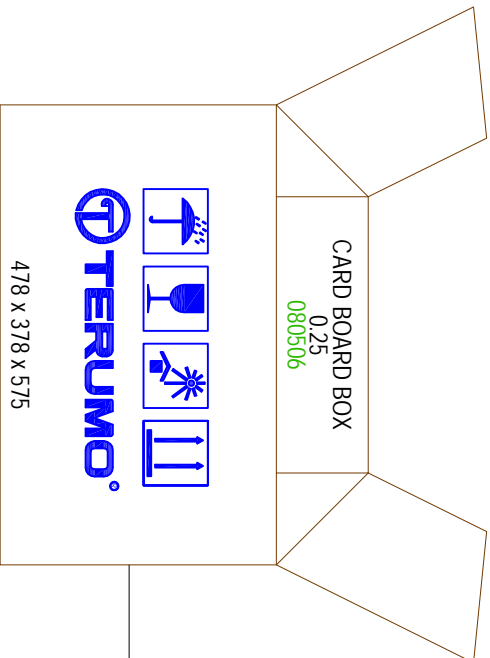

CARDBOARD BOX
0,25
080506

478 x 378 x 575



PACKING INFORMATION

EACH GAS POUCH IS TO BE PACKED IN A CARDBOARD TRAY, ONE ON TOP OF ANOTHER. 4 PACKS PER BOX

TOP:
24-25-26
7-8-9-11-12-13-14-18
19-21-5-6-23
15-17-16-20-22
1-2-3-4

PACK LABEL EXAMPLE

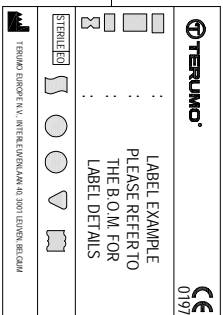

BOX LABEL EXAMPLE

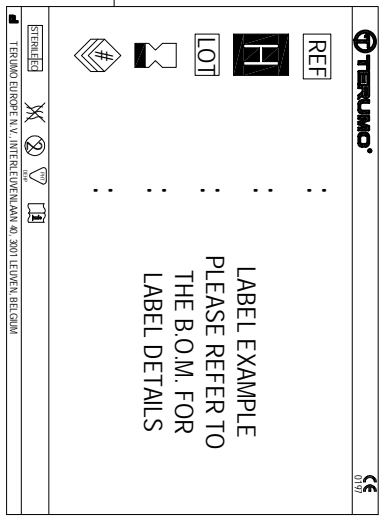

CUSTOMER:

CIP CHISINAU
MOLDOVA

DESCRIPTION:

PAEDIATRIC PACK FOR USE WITH FX15RW40

PRODUCT CODE:

CX-ML025

DRAWING TYPE:

PRODUCTION

Total Priming Volume:

XXX

DRAWN BY:

SHIRLEY COURTNEY
INT. AMEND: 28/03/2019-SF

ISSUED:

26/02/2016
AMENDED: 16/04/2019-SF

ISSUE No:

6
SHEET No: 5/5

THIS DOCUMENT IS THE PROPERTY OF TERUMO EUROPE AND MAY NOT BE COPIED BY ANY THIRD PARTY.

