

Item	Typ. Power	Pin Code
LP405-SF10	10mW	B
LP488-SF20	20mW	B
LP515-SF3	3mW	A
LP633-SF50	50mW	G
LP635-SF8	8mW	A
LP637-SF50	50mW	A
LP637-SF70	70mW	G
LP642-PF20	20mW	A
LP642-SF20	20mW	A
LPS-660-FC	7.5mW	C
LPM-660-SMA	7.5mW	C
LP660-SF20	20mW	A
LP660-SF40	40mW	H
LP660-SF50	50mW	C
LP660-SF60	60mW	H
LP685-SF15	15mW	C

Item	Typ. Power	Pin Code
LP705-SF15	15mW	C
LP730-SF15	15mW	A
LPS-785-FC	10mW	A
LPS-PM785-FC	6.25mW	A
LP785-SF20	20mW	A
LP820-SF80	80mW	C
LPS-PM830-FC	10mW	C
LPS-830-FC	10mW	C
LP850-SF80	80mW	C
LP880-SF3	3mW	A
LP904-SF3	3mW	A
LP980-SF15	15mW	E
LPSC-1310-FC	50mW	E
LPSC-1550-FC	50mW	E
LPSC-1625-FC	50mW	E

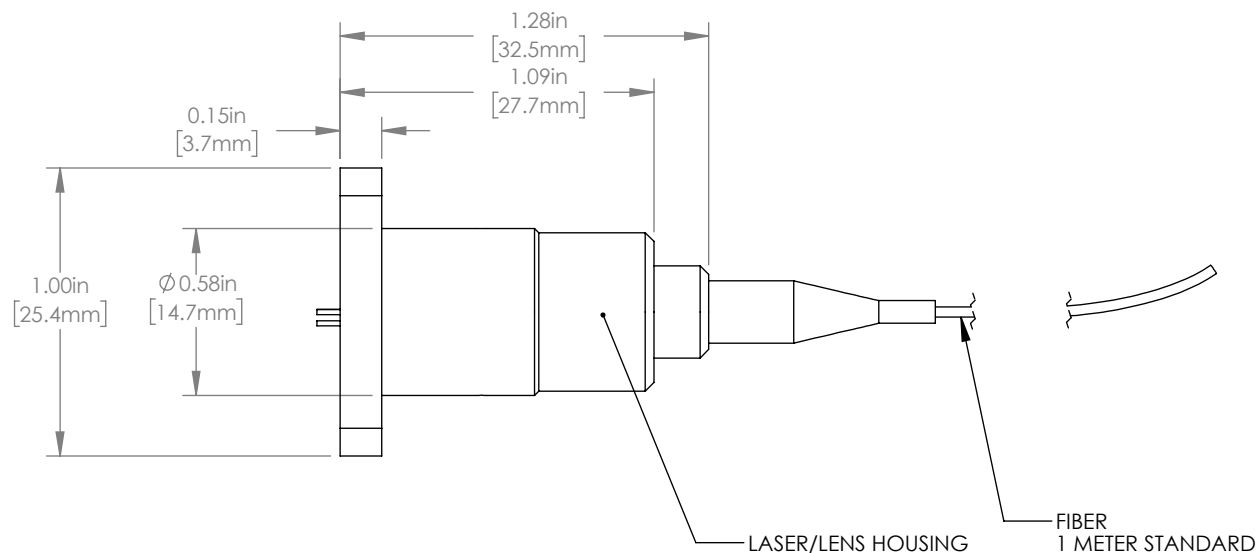
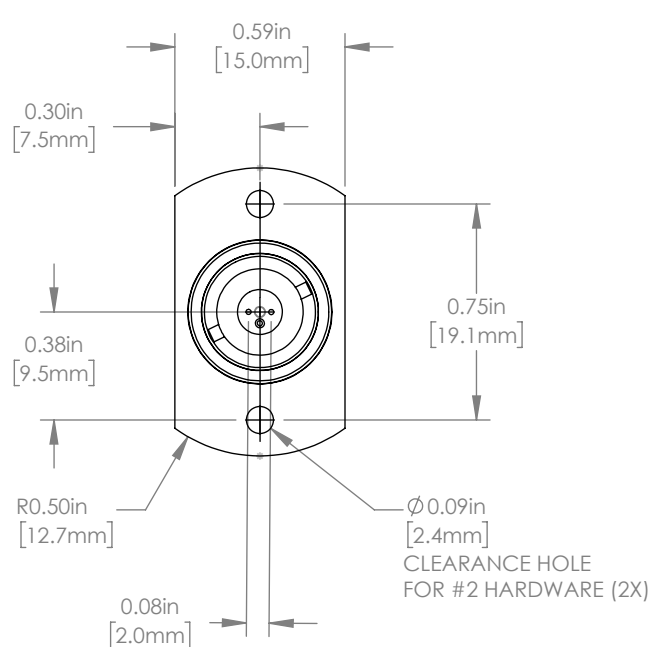
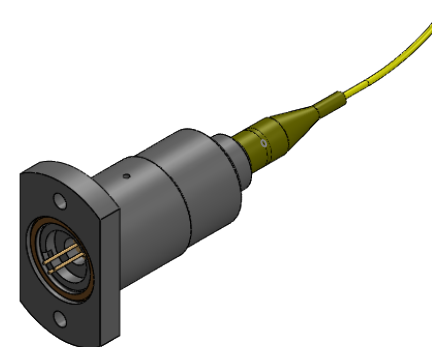

FOR INFORMATION ONLY
NOT FOR MANUFACTURING PURPOSES

DRAWING PROJECTION			THORLABS www.thorlabs.com	
NAME	DATE	PIGTAILED LASER WITH 3-PIN 5.6MM DIODE		
DRAWN JS	07/02/19	MATERIAL	N/A	REV G
APPROVAL YH	07/02/19	ITEM #	SEE TABLE	APPROX WEIGHT 0.13 kg
<small>COPYRIGHT © 2019 BY THORLABS VALUES IN PARENTHESIS ARE CALCULATED AND MAY CONTAIN ROUND OFF ERRORS</small>				