



TECHNICAL DESCRIPTION MANUAL PROMED P300

Technical data	
Data of PROMED P300	
Name of machine	PROMED P300
Measurements(LxWxH)	2250x2500x4200 (Aprox. with platform and upper lid open status)
Volume of upper chamber	450 liter (minimum)
Volume of lower chamber	250 liter (minimum)
Machine weight when empty	2500 kg (Sterilizer only)
At testing	
Total weight	5700 kg
Steam	7 bar
Pressurized water	10 bar (If water cooling applied)
Operating characteristics	
Cycle time	35 - 45 minutes
Volume of treated waste	450 liters
FO sterilization value	8 Log 10 (minimum)
Consumption per cycle	
Steam consumption	15 kg
Electric consumption	5 kWh
Water consumption	0 liters (Air cooling will be applied)
Connections requested	
Steam	1.1/5" / 6 - 8 bar
Air pressure	1/2" / 8 bar (Supplied by Vertisa)
Water	NA (Air cooling to be applied)
Decreasing of pressure	1"
Electric	(3 phase + null)
Capacity	380 V - 410 V/ 50 Hz, 21 kW
Ceiling height	Minimum 5 Meters
Floor support	Able to support 6.000 KG / 4 m2 (1500 Kg/m2)

Materials

The materials used for the tank and lids are all stainless steel type 321 quality (Asth USA Standard). The shredder is made of high strength heat treated quality steel, which has a high resistance to fatigue and attrition.

The non stainless steel components are treated with anti-corrosion materials.

Quality control

The quality control is done according to the manufacturer's standard quality control.

General description

Nomination

PROMED P300 is a sterilizing equipment for infected dangerous waste originating from public health activity

Field of utilization

PROMED P300 equipment is used for the sterilization and decreasing of volume of waste originating from public health.

After shredding the hospital waste to an acceptable size, the sterilization is done by treating the waste and all inner components of the system with 134 °C steam for 10 Minutes. After the sterilization process, the waste is cooled down to for safe handling. (Sterilisation heat programable up to 145°C, also sterilisation time and cooling temperature can be programmed upon request).

The discarded waste can be accepted as steril communal waste. (Minimum Sterilisation efficiency: 6 Log 10)

After sterilizing the waste with heat treatment, PROMED P300 system decreases the volume significantly (up to 1/2 size),which compared to the traditional processes, not only decreases the cost of dumping, but also the cost of transportation.

The process destroys the following micro-organisms:

- bacteria flores, microbacterias, fungus spores
- neutralization of viruses

The equipment is suitable for treatment of general medical waste .

Description of units of equipment

The units of the equipment are illustrated with the help of the following diagrams:

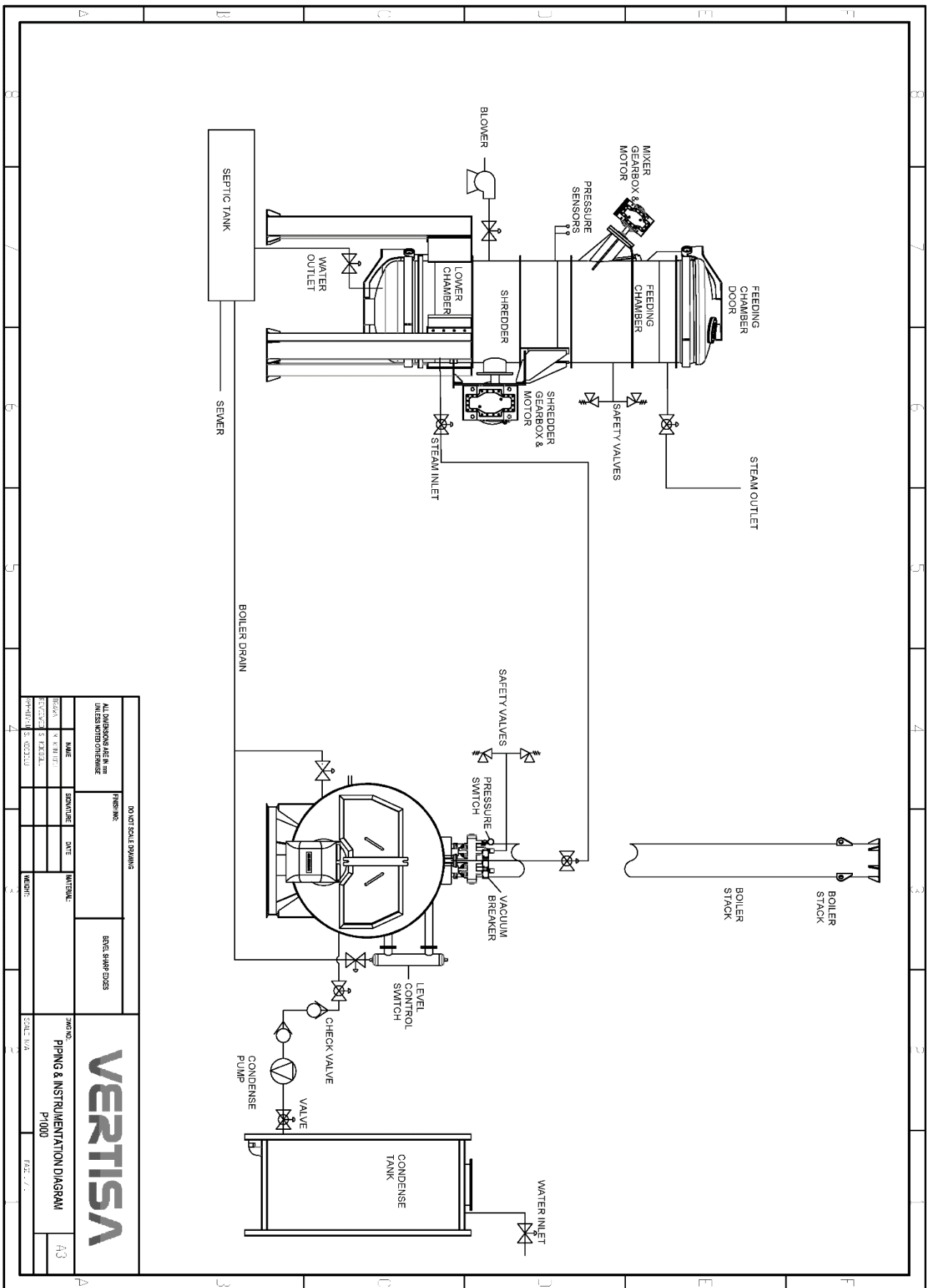

1. Diagram: sketch of machine with main nominations

*Air cooling system to be applied. Water cooling components will be supplied if water cooling system is requested buy customer.

MAIN COMPONENTS OF THE SYSTEM
Openable lid of feeding chamber
Insulation layer on feeding lid
Openable lid of feeding chamber
Opening /closing device of feeding lid (pneumatic cylinder)
Security ring mechanism for feeding lid
Opening /closing device of security ring (pneumatic cylinder)
Security lock mechanism for security lock
Opening /closing device of security lock (pneumatic cylinder)
Position sensor on pneumatic cylinder
Window for checking shredding
Sealing for feeding lid
Mizer arm
Mizer arm motor
Mixer arm pressure sealing components
Funnel over shredder
Shredder unit
Shredder shaft (x1)
Shredder reduction gerabox (x1)
Shredder reduction gerabox motor (x1)
Shredder shaft pressure sealing components
Waste trap door
Waste trap door closing device (pneumatic cylinder)
Water level sensor
Openable lid of discharging chamber
Insulation layer on discharging lid
Openable lid of discharging chamber
Opening /closing device of discharging lid (pneumatic cylinder)
Security ring mechanism for discharging lid
Opening /closing device of security ring (pneumatic cylinder)
Security lock mechanism for security lock
Opening /closing device of security lock (pneumatic cylinder)
Position sensor on pneumatic cylinder
Sealing for discharging lid
Pressor sensor of chamber wall
Pressure sensor
Pressor sensor of treated waste
Mechanical safety pressure valves (2x)
Steam inlet valve

Steam outlet valve
Cooling water/air inlet valve
Draining valve
Pneumatic cylinder actuator valves
Plc control panel
User control panel
Air compressor
Walking platform
Elevator
Elevator control set

OPERATING DESCRIPTION

The operating cycle of PROMED P300 equipment

After the execution of previous cycle the machine is in a sterilized and closed position.

With the pushing of the control button, the Control device permits the feeding. The machine eliminates the pressure of the sealing of the feeding lid, opens the safety ring and lock of the feeding lid and the Operator with the pressing of the permission button opens the feeding lid and stays steady for feeding.

Feeding is done by with the help of the container elevator. The waste must be placed in the upper chamber.

While feeding, the shredder is switched-off through-out the feeding process , for safety precautions.

After closeing the upper chamber air-tight, the PLC unit starts the sterilizing program, which automatically operates till discharging (Except shredding start activation by button).

First the feeding lid ring and bolt closes and the seal is put under pressure.

The machine checks the air-tight closing.

The first phase of the sterilizing program is the shredding, the shredder starts automaically, and with an optimum program cuts the waste into the required size. In the mean time the waste arranging machine (mixer) moves the cartons and waste bags so that they continously enter into the shredder.

The average shredding time depends on the composition of the waste. The end of the shredding is observed by pushing a control button by the operator.

If shredding is observed automatically for safety reasons the shredding continues for a couple of minutes, so that the waste may completely empty the knives and grate. But as this waste has been sterilized with the rest of the waste also, it does not matter if some waste remains in the shredder as this will be discharged with the next feeding.

After this stage the temperature rises until the temperature in the center of the waste reaches 134 °C.

The temperature of the waste should at least remain at not lower then 134 C. degree for 10 minutes.

The 134 C degree and the time limit of 10 minutes provides the guarantee of the sterilizing of waste.

Please note, that with the temperature the pressure also increases to proportional to temperature. The optimum sterlization and steam consumption is controlled by taking into consideration the quantity of steam, temperature and pressure data.

After the sterlizing has been completed, begins the cooling process of the chamber by blowing pressurized air in the pressure vessel.

After reaching the cooling time , the following steps are made automatically:

- pressure equallizing
- draining of condense water into sewage
- pressure equallizing
- opening of safety ring and lock of discharging lid
- blinking of green lamp to allow Operator to open discharging lid

The opening of discharge lid is done by the Operator by pushing the operating permission button.

When releasing the button the opening process while be interrupted for safety reasons, therefore the Operator must constantly push the button till the opening process is finished.

After this stage the waste collecting container must be positioned below the swing lid. The swing lid opens by constantly pushing the operating permission button.

After the opening of swing lid, pushing the button again will start the shredder, so that the remaining sterilized and shredded waste should fall out – as much as possible. The shredder will stop by pushing the button again, and the closing process of the swing lid will begin by constantly pushing the button.

The Operator pulls out the container and by constantly pushing the operating button, closes the discharging lid. When the lid is closed, the control device automatically closes the lid's safety ring and lock and the sealing is put under pressure

With the completion of this process the sterilizing cycle ends.

The whole cycle is controlled by the Control PLC, which not only controls the system, but by the end of the program records, temperature, pressure, time, the sterilization value etc.. of each phase.

Through the monitor of the PLC the condition of the equipment can always be followed by the operator.

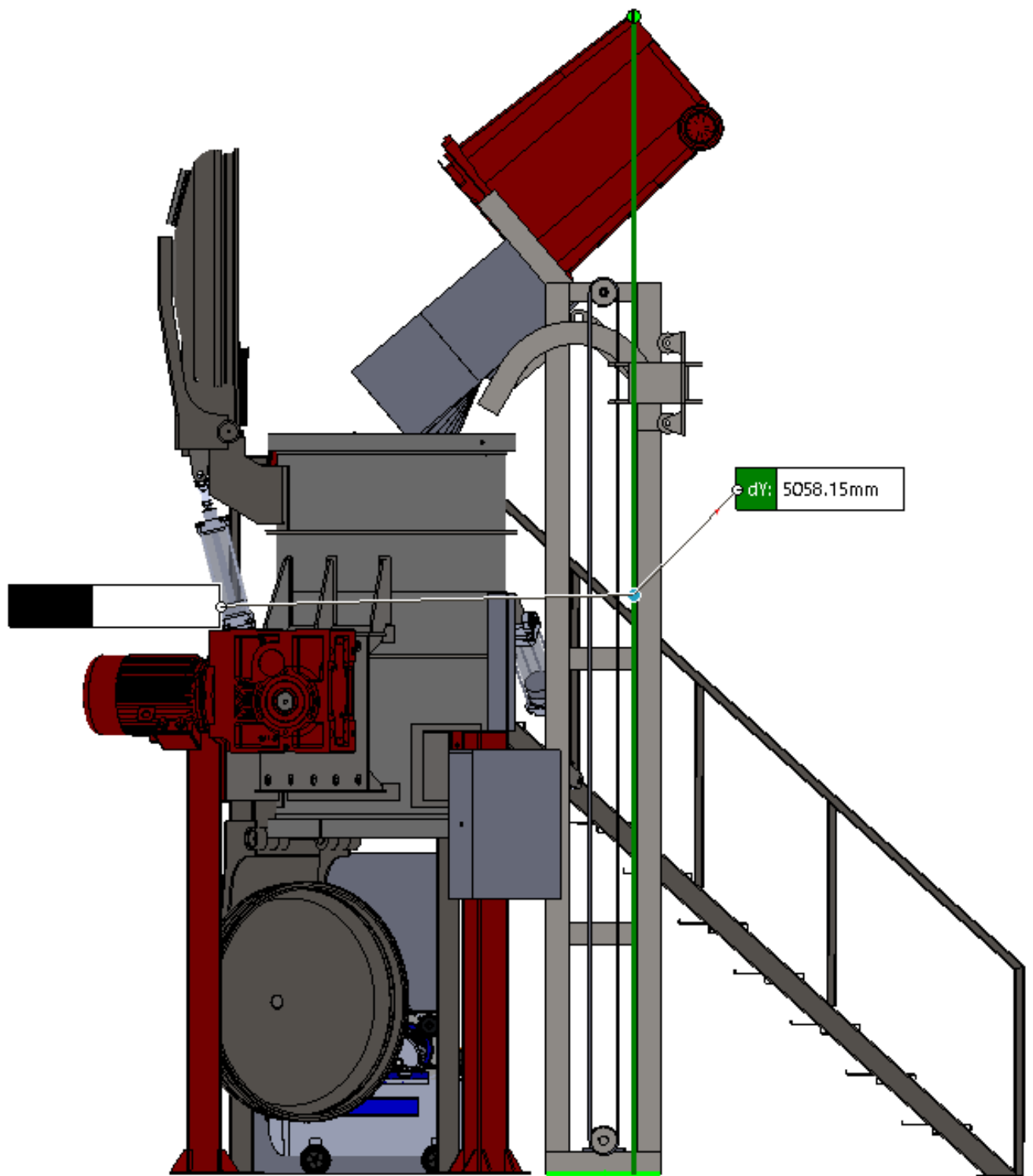

DIAGRAM 1. : HEIGHT OF THE STERILIZER

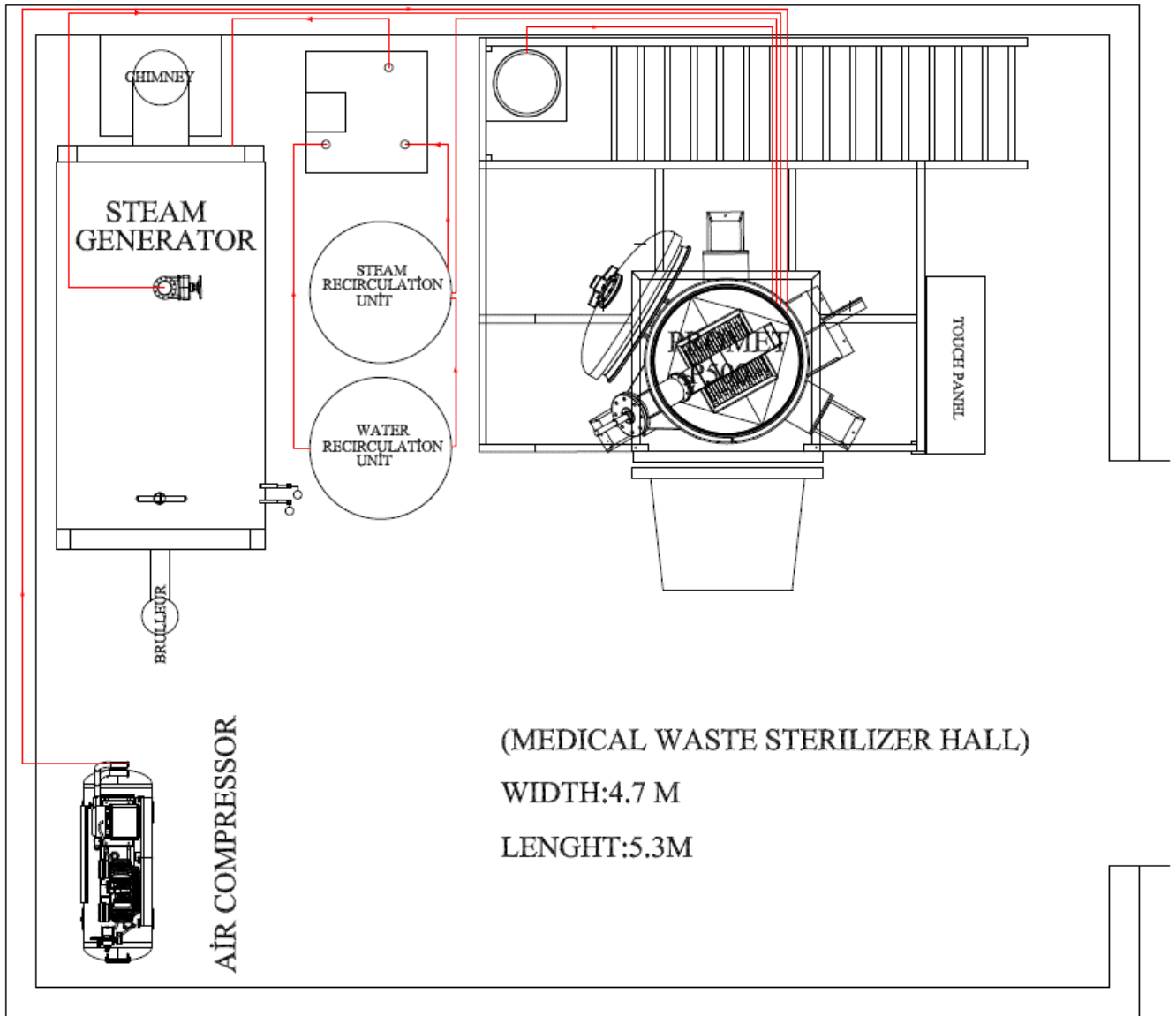

DIAGRAM 2. : SAMPLE LAYOUT THE STERILIZER
(OPTIONAL STEAM BOILER
INCLUDED)

