



OMNI[®] CRRT Set-Up Guide

We
PROTECT
and
IMPROVE
the
HEALTH
of people
around the world

CONTENT

Please note: The numbers shown after the titles and subtitles in this booklet refer directly to the relevant chapters in the IFU for OMNI® SW 1.77.

1. Parameters in CRRT
 2. Seven step process to set-up OMNI® in CRRT
 - 2.1 Scan kit
 - 2.2 Select therapy
 - 2.3 Installation of kit
 - 2.4 Installation of bags
 - 2.5 Automatic priming
 - 2.6 Ready for therapy
 - 2.7 Confirming therapy parameters
 3. Rinsing and recirculation in CRRT
 4. Cancelling preparation
 5. Patient connection
 6. During therapy
 - Starting blood side and fluid side pumps 6.1.5
 - Temporarily disconnecting patient 6.2.3
 - Changing flow rates and parameters 6.2.8
 - Heparin syringe changes 6.2.11
 - Calcium syringe changes 6.2.12
 - Changing bags in CRRT therapies 6.2.13
 - Changing disposable kit 6.2.15
 - Changing therapy type 6.2.16
 - Changing anticoagulation type 6.2.18
 - Adding anticoagulation to the therapy 6.2.19
 - Blood return/end of therapy 6.3
 7. Unloading disposables
 8. Post treatment
-

1. Parameters in CRRT 3.5.15.1

- 1 Input field for net fluid removal flow rate
- 2 Calculated predicted daily removal
- 3 Input field for substitution fluid flow rate
- 4 Input field for dialysate flow rate
- 5 Calculated filtration ratio
- 6 Calculated real renal dose
- 7 Calculated target renal dose
- 8 Calculated set renal dose



Regional Citrate Anticoagulation

- 1 Input field for citrate dose
- 2 Calculated citrate flow rate
- 3 Calculated remaining volume in citrate bag and remaining time until bag change
- 4 Input field for calcium dose
- 5 Calculated calcium flow rate
- 6 Selected syringe type
- 7 Input field for remaining volume in syringe and remaining time until syringe change
- 8 Change syringe icon



The following parameters can be adjusted in the Anticoagulation screen in RCA:

- Citrate dose
- Remaining volume in syringe

- Calcium dose

The following parameters can be adjusted in the Anticoagulation screen in Heparin:

- Heparin flow rate
- Remaining volume in syringe

2. Seven step process to set-up OMNI[®] in CRRT

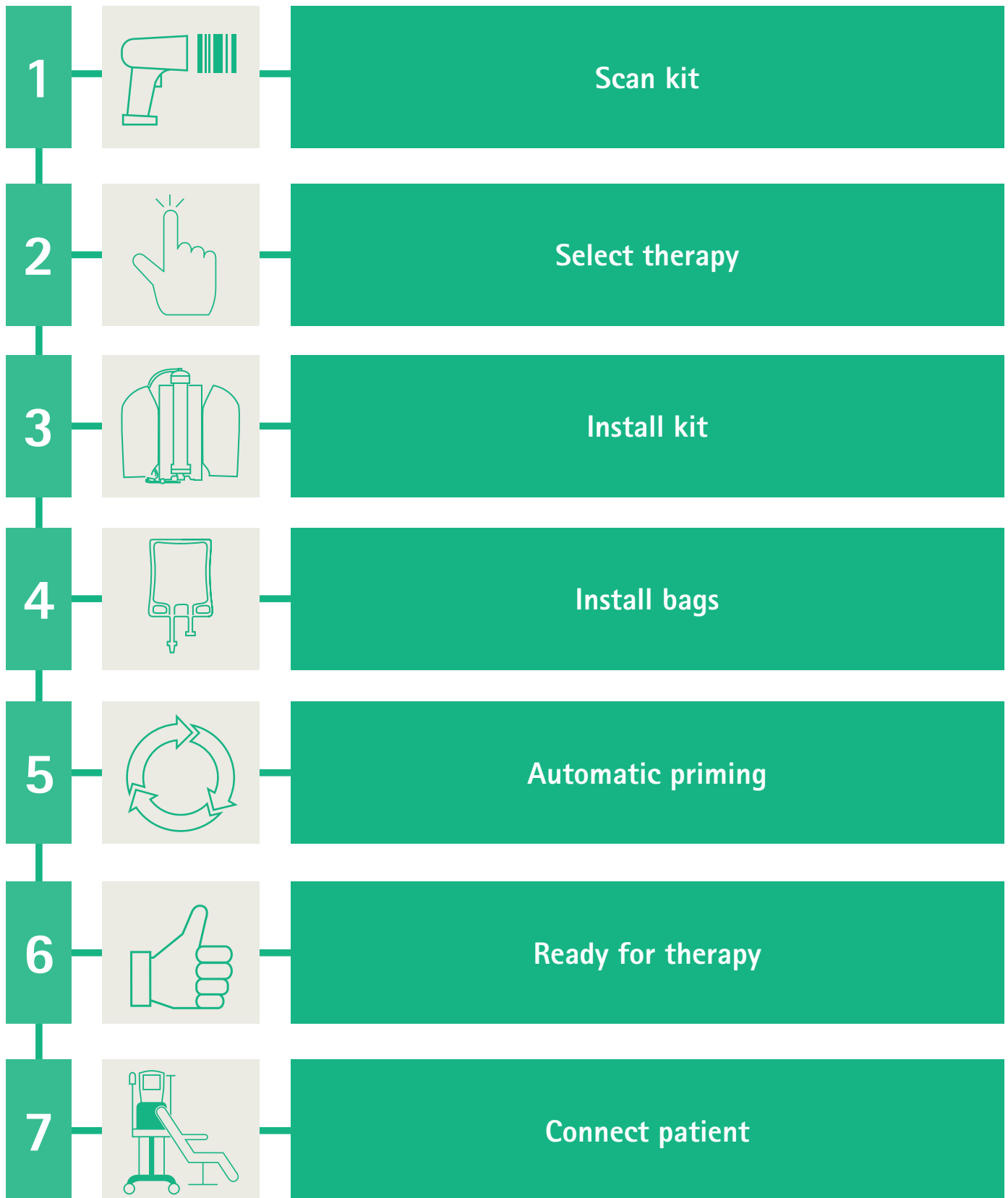

2. Seven step process to set-up OMNI[®] in CRRT

2.1 Scan kit 5.3

Scanning the disposable kit

Scanning the kit is the first of seven steps that constitute the guided preparation procedure.

Make sure that the disposable kit packaging is intact, and the kit is appropriate for the prescribed therapy.

Hold the disposable kit pouch with the barcode close to the barcode scanner.

Align cross point of scanner laser over the centre of the barcode on the disposable kit packaging.

When the barcode scanner has read the barcode, the OMNI will emit an audible sound and the below will be displayed on the touch screen:

Kit type

Article number

Expiration date

LOT number of the disposable kit

Please note that the barcode scanner is deactivated after loading the disposable kit. No further components can be scanned while the disposable kit is loaded.

To proceed to the select therapy step, press next



2.2 Selecting the therapy 5.4

Select the therapy type

The possible therapy settings displayed in this screen depend on the type of disposable kit scanned in the previous step.

The machine starts performing self-tests. Do not install the disposable kit, connect pressure lines, or touch load cells until the self-tests are successfully completed.

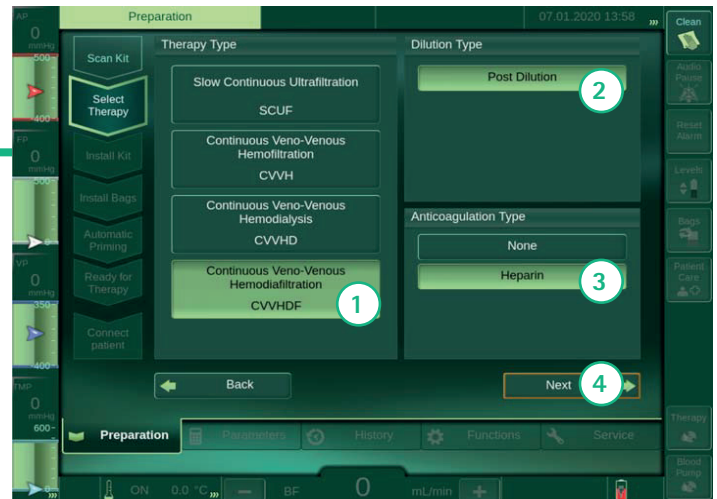

Key 1 Therapy types 2 Dilution types 3 Anticoagulation types 4 Next button

2.3 Installing the disposable kit 5.5

The following tasks must be completed in this step:

Installing the disposable kit

Unpacking the disposable kit and attaching the protective cover

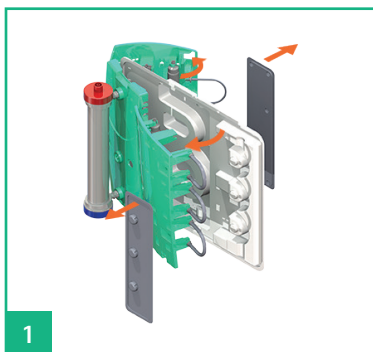

1 Unpack the disposable kit and attach the protective cover.

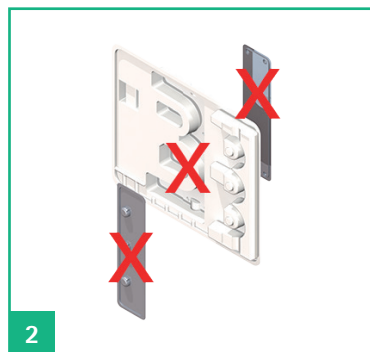

2 Carefully remove, then dispose of kit packaging.

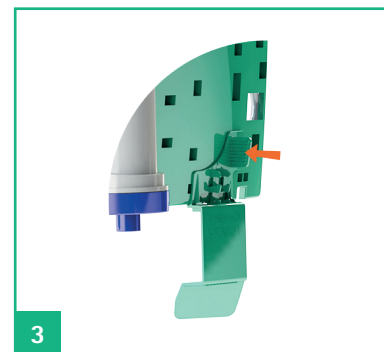

3 Attach the protective cover* on the disposable kit.

*the protective cover is not essential to the performance of the machine. If it is not available, move on to the next step.

2. Seven step process to set-up OMNI[®] in CRRT

2.3 Installing the disposable kit

Loading the disposable kit

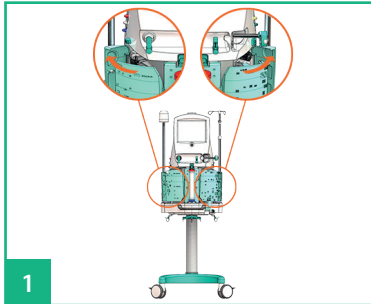

Open the blood and fluid side doors.

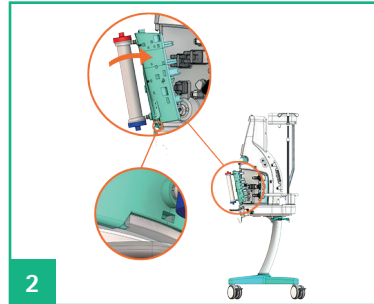

Hold the kit with the red filter cap on the top. Insert the lower part of the kit into the slot above the front handle.

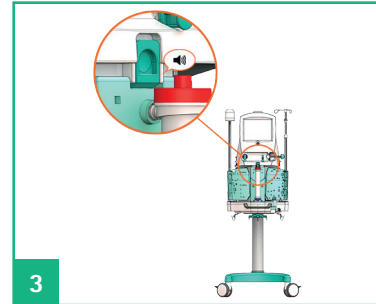

Fix the kit onto the front of the machine using the latch at the top.

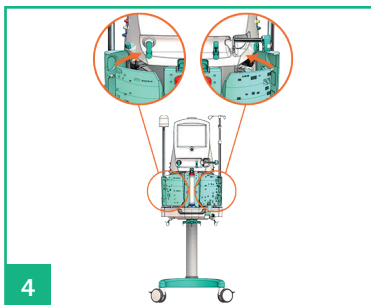

Make sure that no lines are stuck between the kit and the machine. Press disposable kit sides firmly into the locks until you hear the locking mechanism click.

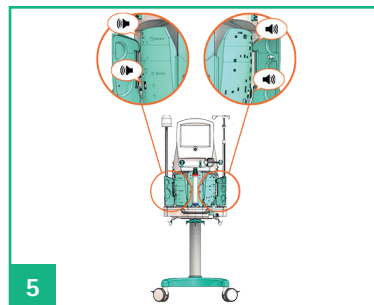

Make sure that both upper and lower locks are engaged.

Closing blood and fluid side doors

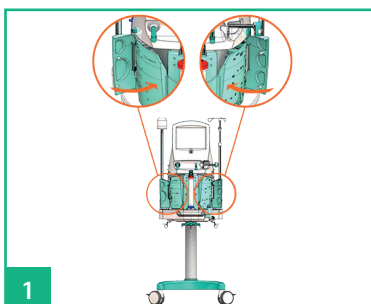

Close the blood and fluid side doors.

Loading the warmer bag

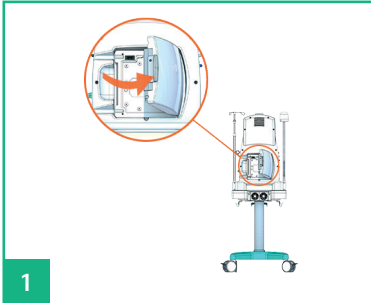

1

Open the warmer door at the back of the machine.

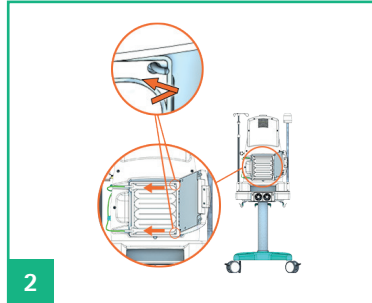

2

Put the warmer bag on the two hooks at the door hinge and the shorter line to the top position.

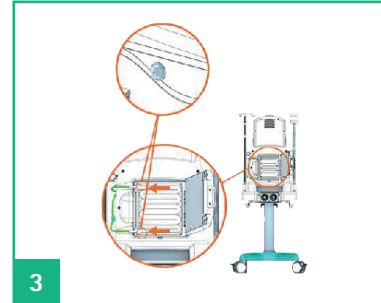

3

Stretch the warmer bag and fix it on the two positioning pins close to the outlets. Make sure that the warmer bag is not kinked or folded.

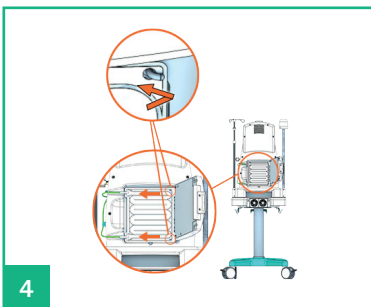

4

Insert the line into the tube holders.

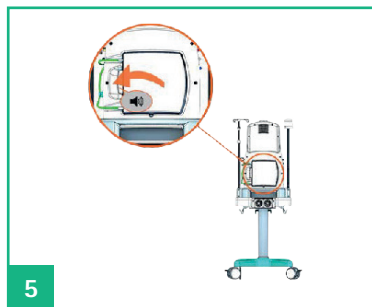

5

Lock the warmer door.

Tip: once the warmer door is closed, **do not reopen** it as it will be very difficult to close again after priming has begun.

Connecting pressure lines

Remove caps from the pressure lines.

Connect them to the following pressure sensor connectors.

Make sure all lines are firmly connected.

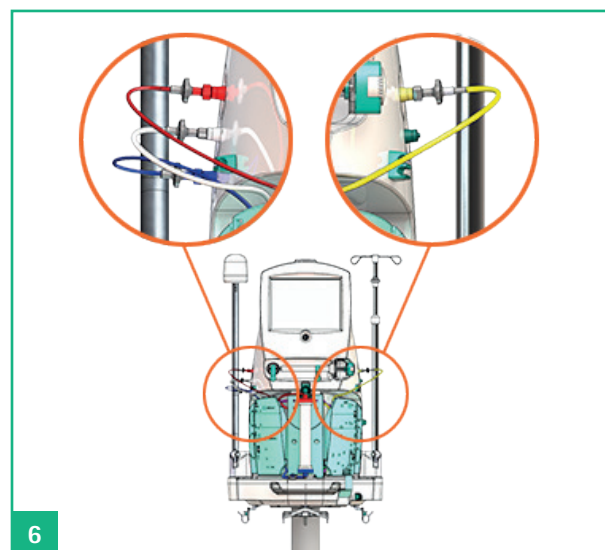

6

Make sure all lines are firmly connected.

2. Seven step process to set-up OMNI[®] in CRRT

2.3 Installing the disposable kit

Setting heparin syringe parameters 5.5.7

Select the appropriate syringe type and size:

- 1 Press the Syringe Type drop-down field ① and the list of supported syringe types opens.
- 2 Select the syringe type with the correct size that you want to use.
- 3 Press the Filled Volume field and the numeric keypad opens.
- 4 Enter the volume of the solution in the syringe in mL and confirm the input with Done.



Loading the anticoagulation syringe 5.5.8

Syringe pump:

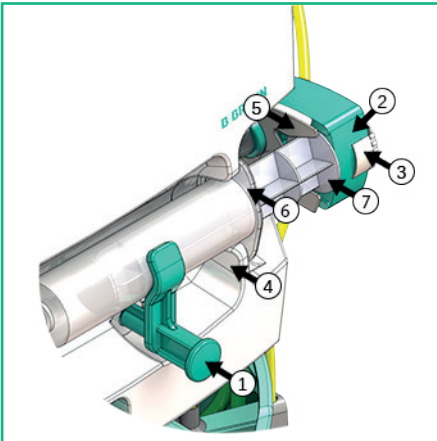

Key

- 1 Unlocking lever
- 2 Syringe holder
- 3 Clasp nut
- 4 Slot - for gripping plate
- 5 Clip - for piston plate
- 6 Gripping plate
- 7 Piston plate

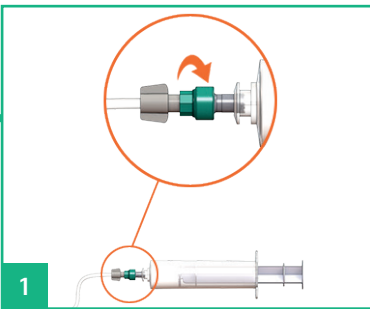

1

Remove cap from the heparin line and connect it to the heparin syringe.

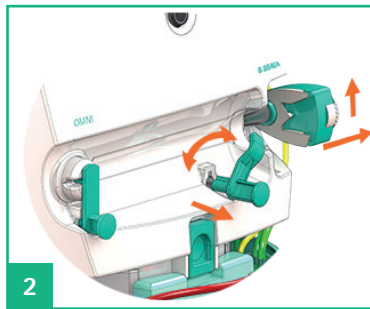

2

Open the unlocking lever and the syringe holder by flipping the clasp nut. Keep the clasp nut open while adjusting the rod to the desired position.

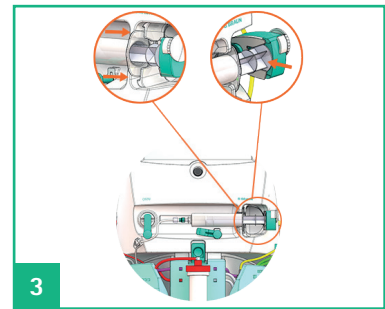

3

Insert the syringe piston plate into the clip and the gripping plate into the slot - the clasp nut should close automatically.

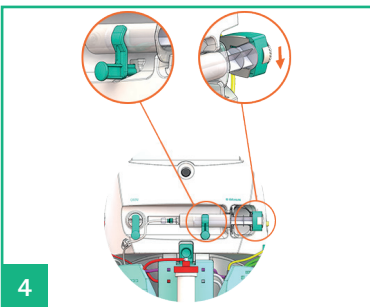

4

Close the syringe holder and make sure that the clasp nut has been closed.

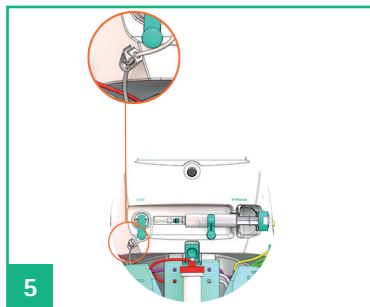

5

Make sure the clamp on the heparin line is open.

When using calcium:

Open the tube holder and insert the calcium line in the calcium safety air detector.

6

Make sure the clamp on the air removal line is closed.

7

Completing kit installation

Press the Load button and wait until the machine confirms that all tasks have been successfully completed.

Proceed to the Install Bags step, press Next

2. Seven step process to set-up OMNI[®] in CRRT

2.4 Installing the bags in CRRT therapies

Installing the bags in CRRT therapies 5.6

Installing bags is the fourth of seven steps that constitute the guided preparation procedure. The bags with the required fluids have to be provided in this step.

Depending on the disposable kit type and selected therapy type, different bags are required on the load cells and IV pole:



Key 1 Selection field for number of effluent bags

Therapy	Bags	Load cell	Therapy	Bags	Load cell
SCUF	Effluent bag and saline bag	Centre	CVHD with heparin	Effluent bag and saline bag	Centre
	-	Left		Saline bag	Left
	-	Right		Dialysate bag (calcium-free)	Right
	Waste bag	IV pole		Waste bag	IV pole
CVH pre-dilution	Effluent bag and saline bag	Centre	CVHD with RCA	Citrate bag	Citrate
CVH post-dilution	Saline bag	Left		Effluent bag and saline bag	Centre
	Substitution bag	Right		Saline bag	Left
	Waste bag	IV pole	Dialysate bag (calcium-free)	Right	
CVH pre-post-dilution	Effluent bag and saline bag	Centre	CVHDF with heparin	Waste bag	IV pole
CVH post-post-dilution	Substitution bag	Left		Effluent bag and saline bag	Centre
	Substitution bag	Right		Substitution bag	Left
	Waste bag	IV pole	Dialysate bag	Right	
			CVHDF with RCA	Waste bag	IV pole
				Citrate bag	Citrate
				Effluent bag and saline bag	Centre
				Substitution bag	Left
				Dialysate bag (calcium-free)	Right
				Waste bag	IV pole

Installing the effluent bag (centre load cell)

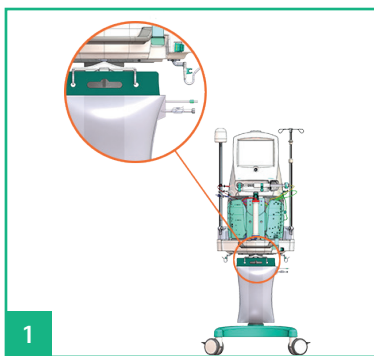

1
Hang an effluent bag on the centre load cell. Make sure that the inlet is on the right side of the bag.

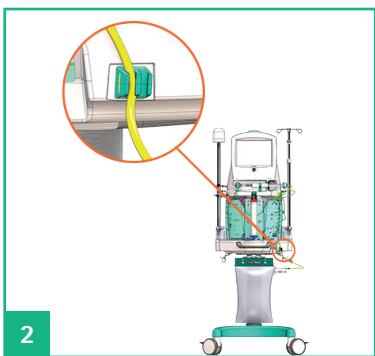

2
Insert the effluent line (yellow) into the tube holder.

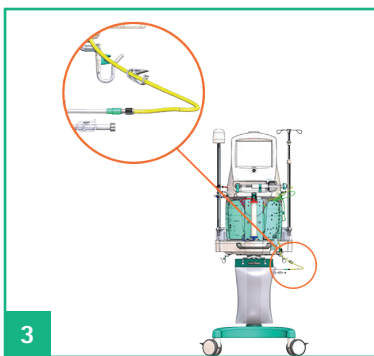

3
Remove cap and connect the effluent line (yellow) to the effluent bag.

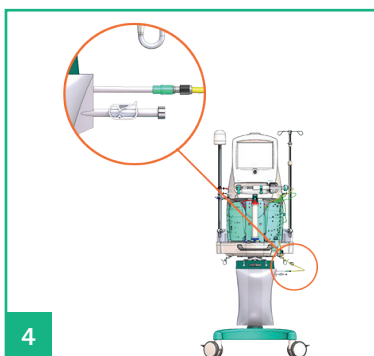

4
Close drain outlet.

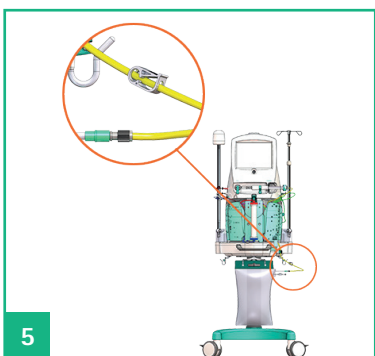

5
Make sure that clamp is open on the effluent line.

Installing a saline bag for priming

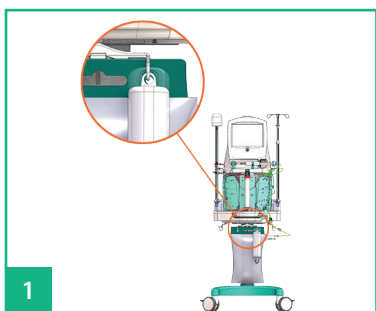

1
Hang a saline bag (minimum 1000 mL but not more than 2000 mL) on the centre load cell next to the effluent bag.

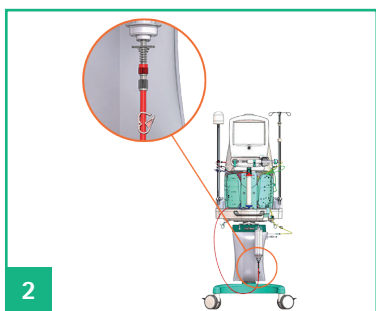

2
Remove cap and connect the arterial line (red) to the saline bag. If necessary, break the frangible pin in the bag outlet.

Make sure that the bags and lines hang freely and do not rest on the base or hooks. Make sure that the line clamps are closed on all lines not being utilised.

2. Seven step process to set-up OMNI[®] in CRRT

2.4 Installing a saline bag for priming (left load cell)

Installing the substitution bag (left load cell)



1

Hang a saline bag (minimum 500 mL) on the left load cell.

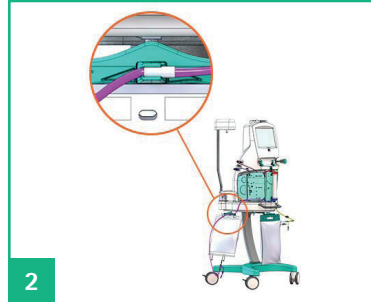

2

Insert the substitution line (purple) into the tube holder.



3

Remove cap and connect the substitution line (purple) to the saline bag.

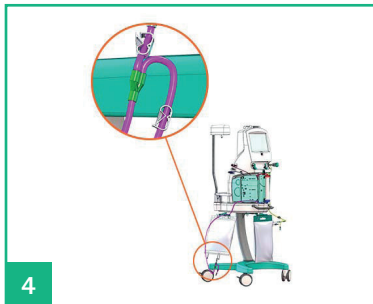

4

Clamp the unused substitution line and open clamp on the used line, if needed.



5

Break the frangible pin in the bag outlet.

Make sure that the bags and lines hang freely and do not rest on the base or hooks.

Make sure that the line clamps are closed on all lines not being utilised.

2. Seven step process to set-up OMNI[®] in CRRT

Installing the substitution/dialysate bag (right load cell)

Consult the instructions for use of the substitution bag. Mix the content of the compartments, if applicable.



1

Hang one or two substitution/dialysate bags on the right load cell.

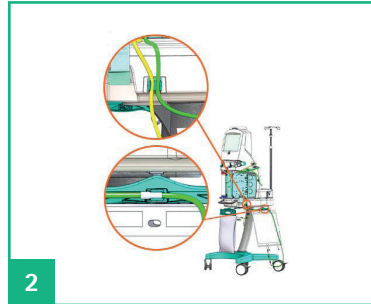

2

Slide the substitution/dialysate line (green) into the tube holder.

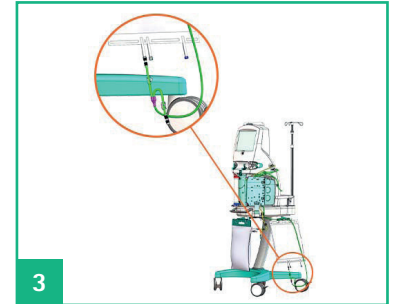

3

Remove cap(s) and connect the substitution/dialysate line (green) to the substitution/dialysate bag or bags.

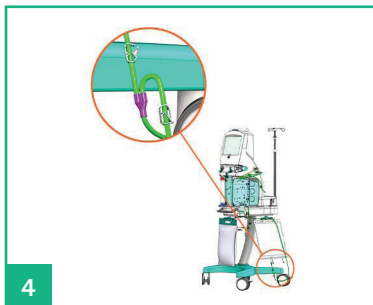

4

Clamp the unused substitution/dialysate line and open clamp(s) on the used line(s), if needed.

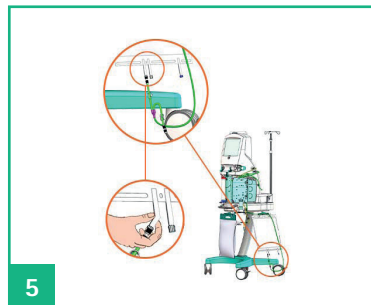

5

Break the frangible pin in the bag outlet.

Make sure that the bags and lines hang freely and do not rest on the base or hooks.

Make sure that the line clamps are closed on all lines not being utilised.

Installing a waste bag for priming (IV pole)

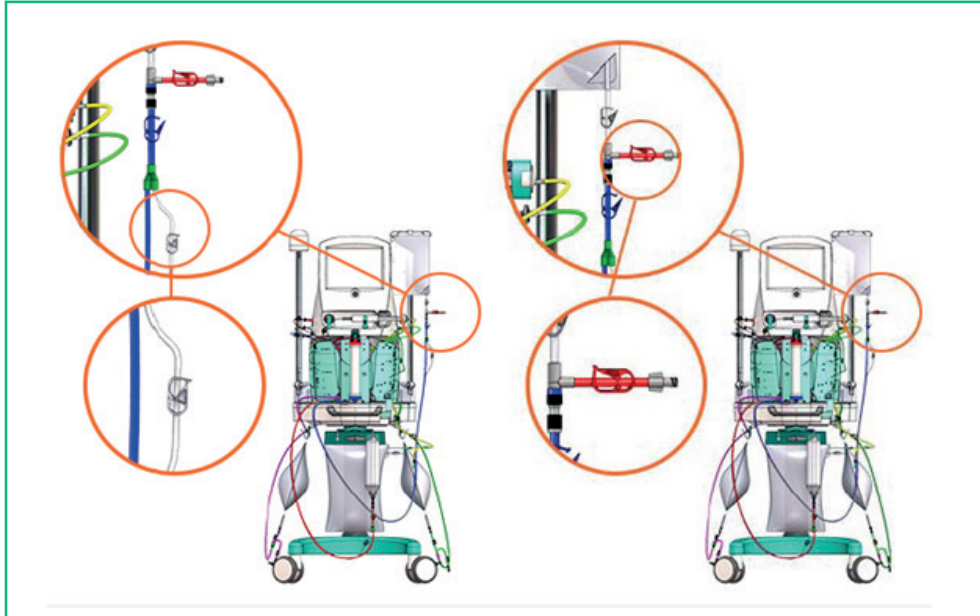

Hang the priming waste bag attached to the venous line (blue) on the IV pole.

Close clamp on calcium line connected to venous line (blue).

Close clamp (red) on priming waste bag T-piece.

2.4 Installing the citrate bag (citrate load cell)

Installing the citrate bag (citrate load cell)

Consult the instructions for use of the citrate bag. Make sure that the citrate concentration matches the displayed value.



1

Hang the citrate bag on the citrate load cell.

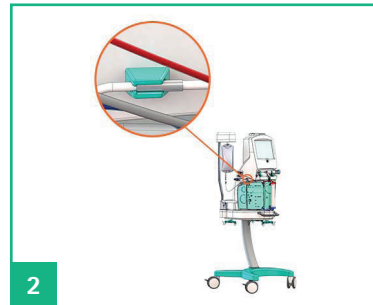

2

Insert the citrate line into the tube holders.

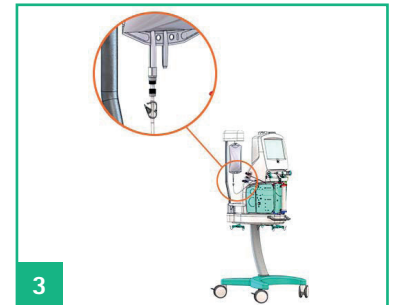

3

Connect the citrate bag to the citrate line.



4

Open clamp on the citrate line if needed.

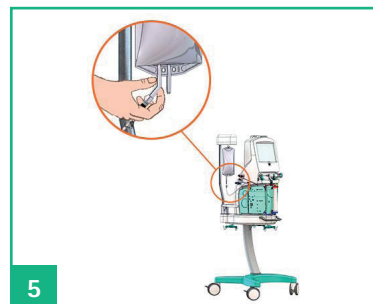

5

Break the frangible pin in the bag outlet.

Press the  symbol to view the step-by-step instructions of the user guide.

2. Seven step process to set-up OMNI[®] in CRRT

2.5 Automatic priming 5.8

Automatic priming

During priming all lines are filled with fluid in order to remove air and any remaining particles.

Press the **(i)** symbol to view the step-by-step instructions of the user guidance. **Make sure that all used clamps are open and all unused ones are closed.**

Press automatic priming **(2)**.

- The machine primes and rinses the disposable kit.
- The progress of priming is indicated on the screen as well as how much time remains until it is finished.

Do not touch the bags and the disposable set on the machine and wait until automatic priming is finished

To interrupt priming, press the automatic priming button **(2)**. To resume priming, press automatic priming again **(2)**.

To proceed to the ready for therapy step, press next **(3)**

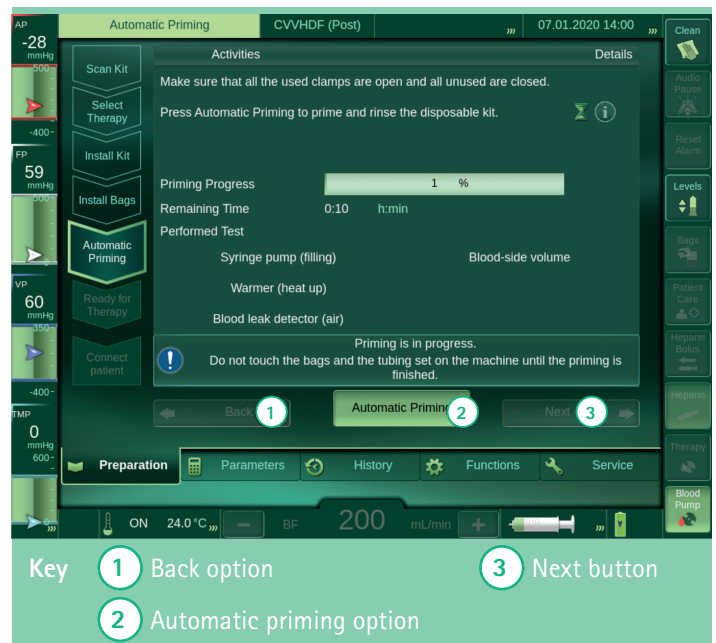

2.6 Ready for therapy 5.9

Ready for therapy is the sixth of seven steps that constitute the guided preparation procedure.

You may either directly proceed to the next step and complete preparation or choose one of the following two options:

Optional rinsing

The machine rinses the disposable kit with a specified amount of additional fluid. This function can be used e.g. to compensate for intolerances of the patient in terms of residual substances in the system.

Optional recirculation

Venous and arterial line are connected to a saline bag. Saline solution is circulated through the blood lines. This function can be used in order to keep the system on standby until the patient can be connected.

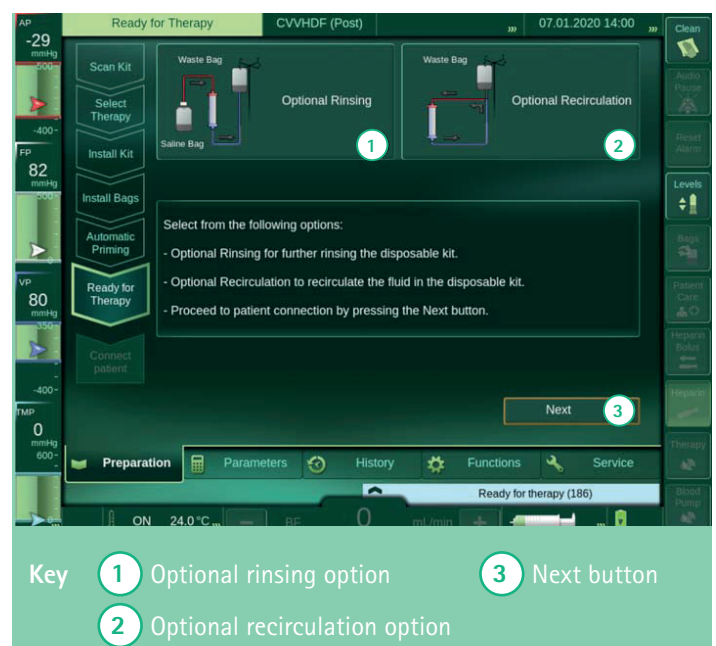

2.7 Confirming therapy parameters

Confirming therapy parameters

- 1 To return to the previous step, press the green arrow ①.
- 2 To proceed to the next step and connect the patient, press confirm ②.

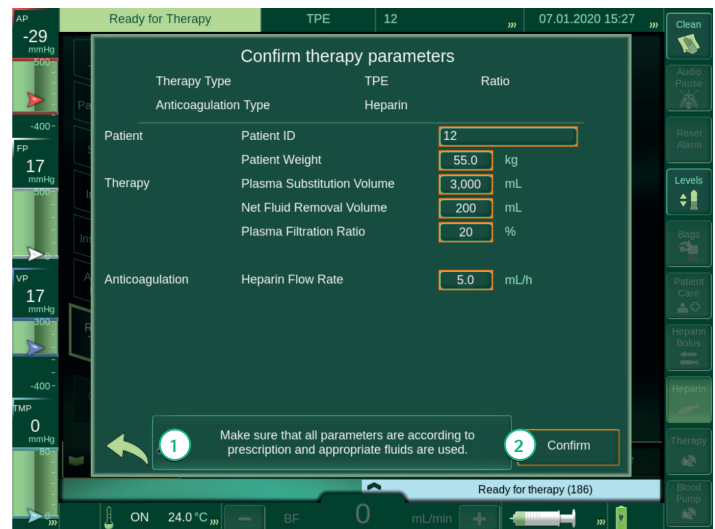

Parameters to be set in CRRT:

- Press the net fluid removal field and enter the fluid volume to be hourly removed from the patient's blood but not replaced by substitution fluid.
- Press the substitution (pre) field and enter the substitution fluid volume to be hourly infused into the extracorporeal circuit (before the haemofilter).
- Press the substitution (post) field and enter the substitution fluid volume to be hourly infused into the extracorporeal circuit (behind the haemofilter).
- Press the dialysate field and enter the dialysate volume to be hourly infused into the haemofilter.

Parameter to be set in CRRT with heparin anticoagulation:

- Press the heparin flow rate field and enter the volume of anticoagulant to be hourly infused into the arterial line.

Parameters to be set in CRRT with RCA:

- Press the citrate dose field and enter the volume of citrate to be infused into the arterial line for each litre of blood.
- Press the calcium dose field and enter the volume of calcium to be infused into the venous line for each litre of effluent.

Parameters additionally displayed in CRRT with RCA:

- Concentration of citrate solution.
- Concentration of calcium in syringe.
- Concentration of calcium in substitution fluid (**CVHDF only**).

The concentration values can only be set by the service technician.

Before confirming therapy parameters, make sure all parameters are according to prescription and appropriate fluids are used. It is only possible to complete preparation and continue to the next step, when all mandatory fields are filled in:

1

To return to the previous step, press the green arrow ①

2

To proceed to the next step and connect the patient, press confirm ②

3. Rinsing in CRRT therapies

Rinsing in CRRT therapies 5.9.1

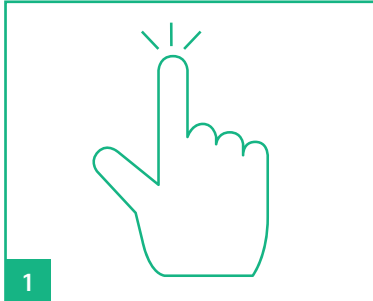

Select the Optional Rinsing option ① on the touch screen. Press the ⓘ symbol to view the step by step instructions of the user guidance.

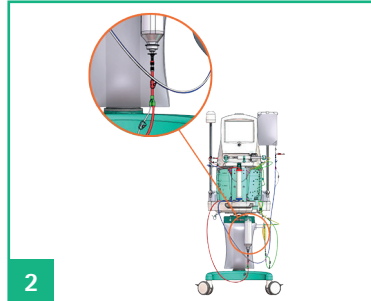

Connect the arterial line (red) to the saline bag on the centre load cell.

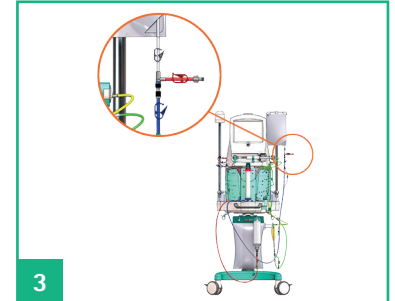

Connect the venous line (blue) to the priming waste bag on the IV pole.

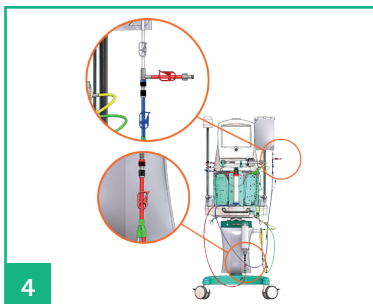

Open the clamps on the arterial line (red) and the venous line (blue).

Setting the rinsing parameters

1 To change the pre-set blood side rinsing volume, press the number in the volume (blood side) field.

The numeric keypad opens.

Type in a new value and confirm with done.

2 If necessary, switch on fluid side rinsing by pressing the ON button.

3 To start rinsing, press the rinsing button.

4 To interrupt rinsing, press the rinsing button. To resume rinsing, press rinsing again.

5 To continue rinsing after the set rinsing volume has been reached, set a new blood side rinsing volume.

6 To proceed to the confirm therapy parameters step, press next ③.

Recirculation in CRRT 5.9.3

1 Select the optional recirculation option ③ on the touch screen.

2 Connect the arterial line (red) to the waste bag:

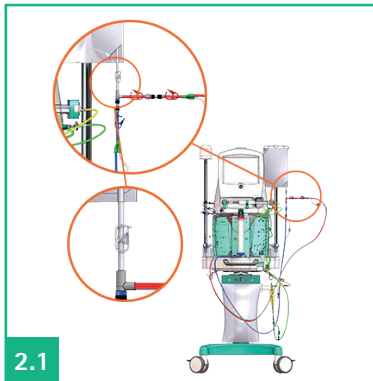

2.1

Close the clamp (white) on the waste bag.

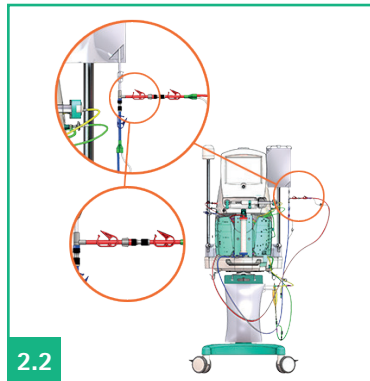

2.2

Connect the arterial line (red) to the venous line using the T-connector at the waste bag. Make sure that the priming waste bag is placed on the IV pole. Make sure that the venous line (blue) is also connected to the priming waste bag.

3 Make sure that the white clamp on the waste bag is closed.

4 Open the clamps on the arterial line (red) and the venous line (blue).

5 To start recirculation, press recirculation.

The blood pump starts recirculating the fluid through the lines of the disposable kit.

The period of time the machine is in recirculation is timed and displayed in the elapsed time field.

6 To interrupt recirculation, press the recirculation button. To resume recirculation, press recirculation again.

7 To proceed to the confirm therapy parameters step, press next.

4. Cancelling preparation 5.11

The preparation of a therapy can be terminated any time with the cancel preparation procedure which is designed to guide you step-by-step through all activities needed to cancel preparation, i.e. disconnecting the lines and bags and removing the disposable kit.

How to start the cancel preparation procedure:

- 1 Press functions ① on the menu bar.
- 2 Press the cancel preparation icon ② on the functions screen.
A confirmation prompt pops up: *Are you sure you want to cancel the preparation process?*
- 3 Press yes to confirm your selection. The unload disposables screen will then appear.



5. Connecting the patient 6.1

Connect patient is used to fill the blood lines and subsequently start the therapy.

White connection

The patient is connected to the arterial line and venous line. The blood lines and the haemofilter are filled with blood from the arterial line. The fluid in the disposable kit is infused into the venous access of the patient.

Red connection

The patient is connected to the arterial line. The blood lines and the haemofilter are filled with blood from the arterial access. The fluid in the disposable kit is collected in the priming waste bag on the IV pole. The venous line is connected to the patient only after the blood lines are filled. The blood lines are filled at a default volume.

5. Connecting the patient

White connection in CRRT therapies 6.1.1

Select the white connection option on the touch screen.

1. Connect the **arterial (red)** and **venous (blue)** lines to the patient:

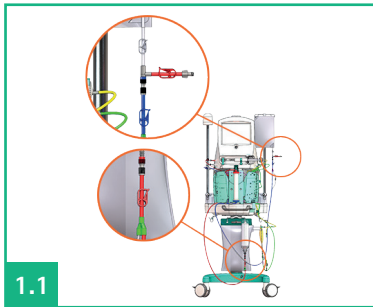

1.1

Clamp the arterial (red) and venous (blue) lines and the corresponding bags.

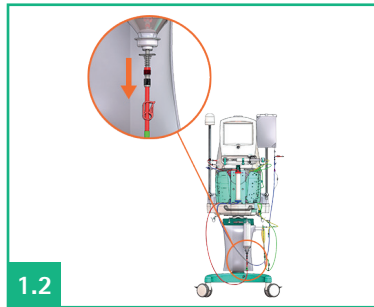

1.2

Disconnect the arterial line (red) from the saline bag.

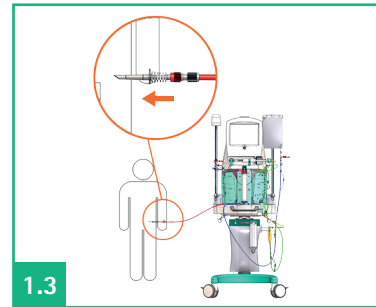

1.3

Connect the arterial line (red) to the arterial access of the patient.

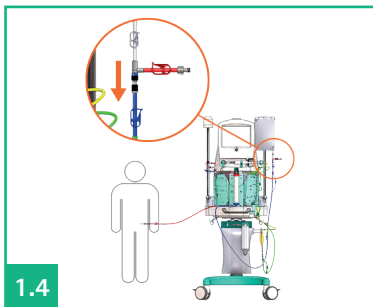

1.4

Disconnect the venous line (blue) from the saline or priming waste bag.

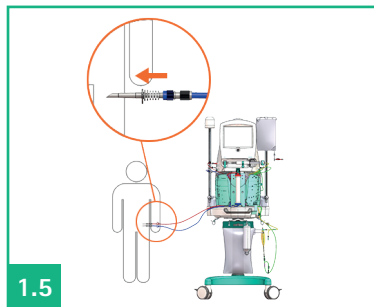

1.5

Connect the venous line (blue) to the venous access of the patient.

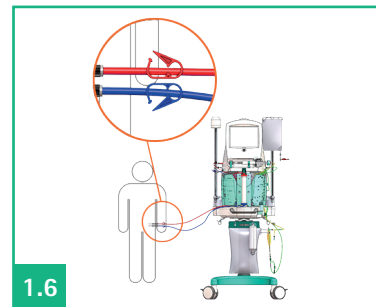

1.6

Open clamps on the arterial (red) and venous (blue) lines and on the patient access.

1.7 Remove waste bag from IV pole and discard it.

2

Remove all non-used bags. Make sure that the saline bag is removed from the center load cell.

3

To start filling the blood lines, press the fill blood lines button. The volume of blood being delivered is indicated on the screen. Closely monitor patient connections during blood line filling. The machine may not detect separation of the venous line.

4

When the blood lines are filled, press the enter therapy button.

The machine enters therapy with a running blood pump.

The machine does not automatically stop the blood pump in white connection.

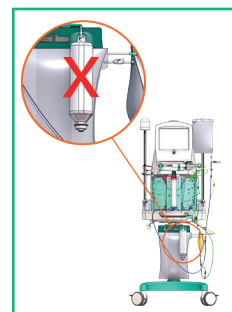

6. During therapy

Starting Blood Side and Fluid Side Pumps 6.1.5

Starting blood side and fluid side pumps

Pressing the blood pump icon during therapy interrupts the operation of all pumps. Pressing the blood pump icon again resumes the operation of all interrupted pumps.

Pressing the therapy icon during therapy interrupts the operation of the fluid side pumps. The blood pump and the heparin syringe continue running. Pressing the therapy icon again resumes operation of the fluid side pumps.

Pressing the heparin icon during therapy interrupts operation of the syringe pump. Pressing the heparin icon again resumes operation of the syringe pump.

Please be careful to not stop the blood pump, therapy or anticoagulation without cause, to avoid interruptions in treatment and possible clotting of blood. The OMNI® stops and starts these functions as required, for example during a bag change, the therapy will stop and start automatically.

When all pumps are running and the therapy has started, the machine indicates this as shown in the following illustration:



Temporarily disconnecting patient 6.2.3

There are two different methods to end the therapy. Use temporarily disconnect patient, the procedure described here, when the therapy is not over, and the patient is supposed to be reconnected to the machine after a short period of time.

1 Press ① functions on the menu bar.

2 Press the temporarily disconnect patient icon on the functions screen. ②

A confirmation prompt pops up: **Are you sure you want to temporarily disconnect the patient?**

3 Press yes to confirm your selection.

The return blood screen appears.



Blood return 6.2.3.1

1 Select the return blood option.

2 Hang a saline bag on the IV pole.

3 Connect arterial line (red) to saline bag and open clamps.

4 To start blood return, press the return blood button and monitor the blood lines.

The blood pump starts feeding back the blood volume set in the return volume field. A progress bar indicates the amount of blood being returned.

The blood return will automatically stop once the return volume has been reached. Alternatively, it can be manually stopped at any time by releasing the return blood button.

5 Release the return blood button when the blood is returned or increase the volume, if necessary.

6 Return additional volume either by pressing the Return +50 mL button or by adjusting the return volume parameter and pressing return blood.

7 Disconnect venous line (blue) from patient.

After blood return, press next to proceed to the recirculation step.

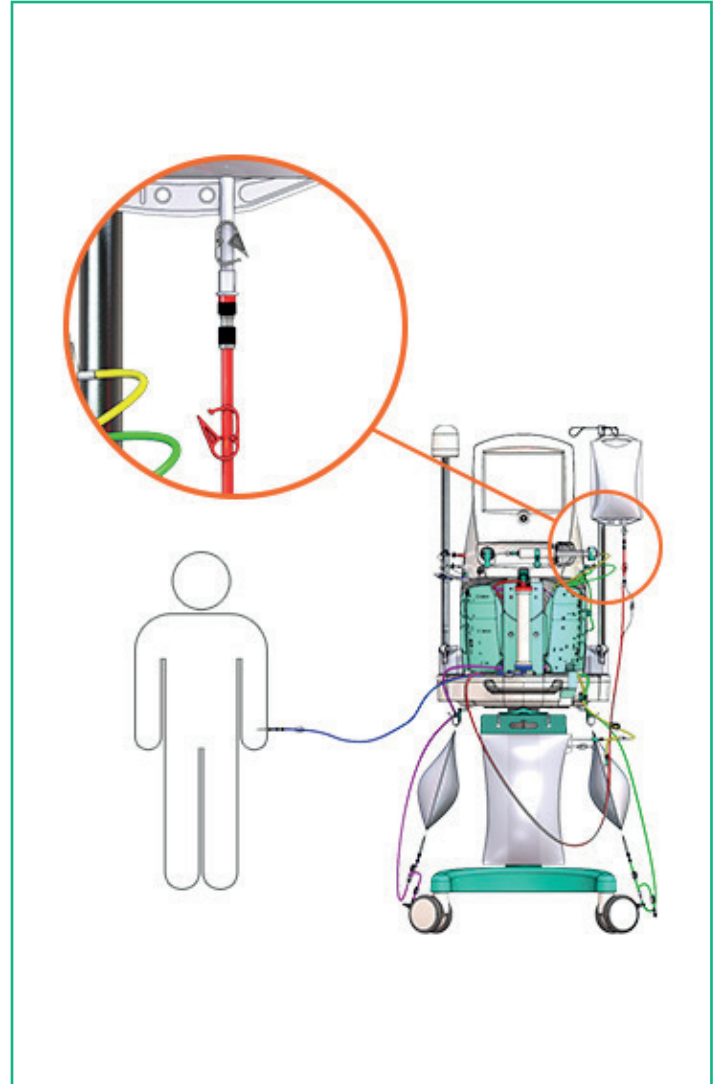

8

Connect the arterial line (red) to the venous line (blue) using a Y-connector or a 3-way tap.

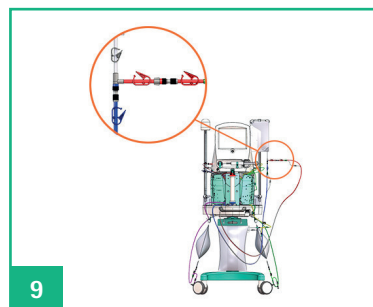

9

Open the clamps on the arterial line (red) and the venous line (blue).

Blood return

- 10 To start recirculation, press recirculation.
 - The blood pump starts recirculating the fluid through the lines of the disposable kit.
 - The time period the machine is in recirculation, is timed and displayed in the elapsed time since patient disconnection field.
- 11 To stop recirculation, press the recirculation button. To resume recirculation, press recirculation again.
- 12 Press reconnect to proceed to the reconnection step
 - The confirm reconnection parameters dialog appears. The parameter settings entered during preparation of the interrupted therapy are displayed for verification.
- 13 Keep or if needed, change the parameter settings.
- 14 To proceed to the next step and connect the patient, press confirm.

Changing flow rates and parameters 6.2.8

Changing flow rates and parameters

Net fluid removal, dialysate flow, substitution flow, and anticoagulation dose and flow rates can be changed during therapy if required.

To open the flow rates screen, select parameters > flow rates on the menu bar.

Heparin syringe changes 6.2.11

Heparin syringe changes

- 1 Press functions or parameters > anticoagulation on the menu bar.
- 2 Press the change syringe icon on the functions or anticoagulation screen.
 - The syringe change screen pops up.
 - Simultaneously, the syringe pump is stopped while the blood pump and fluid side pumps continue running.
- 3 Disconnect and dispose of the syringe and install a new syringe (as per prescription).
- 4 Enter the syringe type and correct filled volume on screen. Press confirm, the heparin syringe will commence once again.

6. During therapy

Calcium syringe changes 6.2.12

When the calcium syringe becomes empty during therapy, it can be replaced with a full one.

Calcium syringe changes

- 1 Press functions or parameters > anticoagulation on the menu bar.
- 2 Press the change syringe icon on the functions or anticoagulation screen.
 - The syringe change screen pops up.
 - Simultaneously, the citrate and syringe pumps are stopped while the blood pump and fluid side pumps continue running.
- 3 Disconnect and dispose of syringe.
- 4 On the syringe change screen, press the syringe type drop-down field.
 - The list of supported syringe types opens.
- 5 Select the syringe type with the correct size that you want to use.
- 6 Press the filled volume field.
 - The numeric keypad opens.
- 7 Enter the volume of the solution in the syringe in mL and confirm the input with done.
- 8 Load new calcium syringe: Make sure that the calcium concentration matches the displayed value.
- 9 Close the unlocking lever properly.
- 10 Make sure that the clamp on the calcium line is open and there is no air in the line.
- 11 Press confirm to return to the therapy.

6. During therapy

Changing bags in CRRT therapies 6.2.13

Changing bags in CRRT therapies

The bags can be changed during therapy.

Depending on the disposable kit type and selected therapy type, the following bags can be changed in CRRT therapies:

Effluent bag on the centre load cell (when full)

Dialysate bag on the right load cell (when empty)

Substitution fluid bag on the left load cell (when empty)

Substitution fluid bag on the right load cell (when empty)

Citrate bag on the citrate load cell (when empty)

To start the bag change procedure, either press the bags icon ①, or select functions > change bag on the menu bar.

The machine automatically determines the number of installed bags and the remaining volume of the bags using the weight of the bag when it is installed. The user has to select the correct number of effluent bags and confirm it by pressing the bag change/weight reset button.

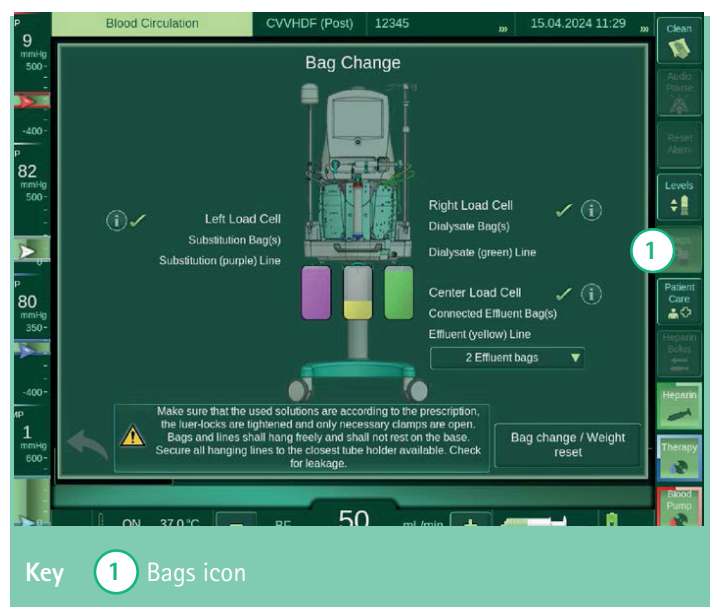

Changing disposable kit 6.2.15

Changing the disposable kit during therapy can be necessary, e.g. when the haemofilter is clogged or defective or when the maximum use time of the disposable kit has been reached. The system supports you in replacing the disposable kit with the change kit procedure.

Changing kit procedure:

- 1 Press functions ① on the menu bar.
- 2 Press the change kit icon ② on the functions screen.
 - A confirmation prompt pops up: **Are you sure you want to change the kit?**
- 3 Press yes to confirm your selection. The return blood screen appears.
 - Simultaneously, the fluid side pumps are stopped.**

When the change kit icon is pressed, the system checks if the remaining therapy time is less than the maximum kit use time of a new disposable kit. As in this case, the new disposable kit cannot be used for the full use time, the system prompts the user to choose one of three options:

- 1 Select back to continue treatment with the same disposable kit if the condition of the disposable kit allows it.
- 2 Select change kit to continue treatment with a new disposable kit for the remaining therapy time. The change kit procedure is started.
- 3 Select end therapy to start a new therapy with a new disposable kit for the full kit use time. The end therapy procedure is started.

The change kit procedure is designed to guide you step-by-step through all activities needed to replace a disposable kit. It is divided into three main steps: return blood, unload disposables and preparation. The purpose of the return blood step is to return the blood remaining in the lines of the disposable kit to the patient. The return blood step is optional, you may skip this step. During unload disposables all lines and bags are disconnected, and the disposable kit is removed. **Finally, you are redirected to the preparation procedure in order to install the new disposable kit and reconnect the patient**

6. During therapy

Changing therapy type 6.2.16

The therapy type may be modified during treatment. If the machine is conducting a CVWH, CVHD or CVHDF therapy, it is possible to switch between these therapy types, provided that the disposable kit supports both therapy types. The software supports you in changing the therapy and dilution type with the change therapy procedure. This function is not available if the therapy type is SCUF nor in TPE therapies.

- 1 Press functions on the menu bar.
- 2 Press the change therapy button on the functions screen.
 - A confirmation prompt pops up: **Are you sure you want to change therapy modality?**
- 3 Press yes to confirm your selection.
 - The select therapy screen appears.
 - Simultaneously, the fluid side pumps are stopped.

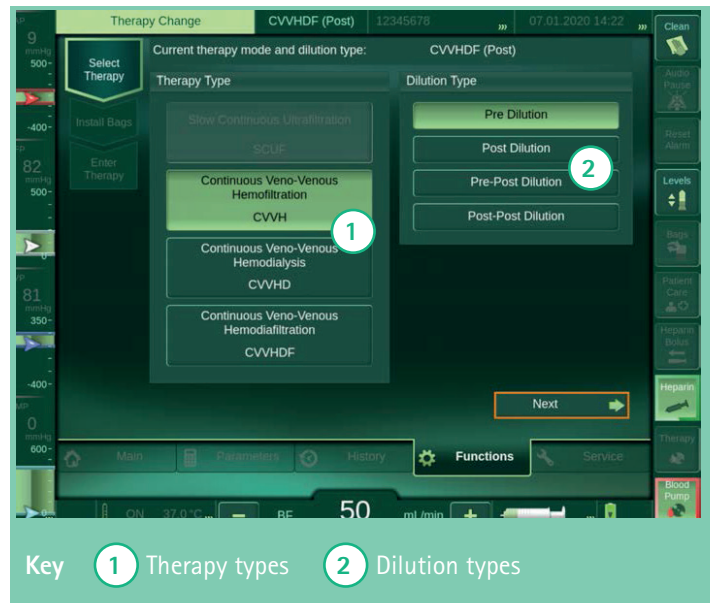

Key 1 Therapy types 2 Dilution types

- 4 After selection of the new therapy and dilution types, the software indicates whether additional fluid bags are required.
- 5 Press the next button to proceed to the next step.
 - The install bags screen appears.
- 6 If the new therapy type requires additional dialysate or substitution fluid bags, follow the instructions of the software where and how to install the bags.
- 7 Press next to proceed to the next step
 - The confirm new therapy parameters screen is displayed.
- 8 If needed, change the values of the therapy parameters or keep them and press the confirm button to complete the procedure.
- 9 To start the therapy with the new therapy type, press the blinking therapy icon.
 - The machine starts running applying the new therapy and dilution type and therapy parameters.

Changing anticoagulation type 6.2.18

In CVVHD and CVVHDF with Regional Citrate Anticoagulation (RCA) it is possible to terminate RCA and continue therapy without anticoagulation. Subsequently, heparin anticoagulation can be started. The software supports terminating RCA with the change anticoagulation procedure.

Changing anticoagulation is not supported when using the disposable kit beyond the recommended kit use time

Changing anticoagulation type:

- 1 Press functions on the menu bar.
- 2 Press the change anticoagulation icon on the functions screen.
 - A confirmation prompt pops up: **Are you sure you want to change anticoagulation type?**
- 3 Press yes to confirm your selection.
 - The select anticoagulation screen appears indicating the selected therapy type and anticoagulation type.
 - Simultaneously, the fluid side pumps, citrate pump and syringe pump are stopped.

How to end RCA and continue therapy without anticoagulation:

- 1 Press the option none ② in the select anticoagulation screen and press next.
 - The unload syringe step is displayed.
- 2 Clamp the calcium line.
- 3 Disconnect and dispose of syringe.
- 4 Change dialysate solution to calcium containing solution.
- 5 Remove citrate bag.

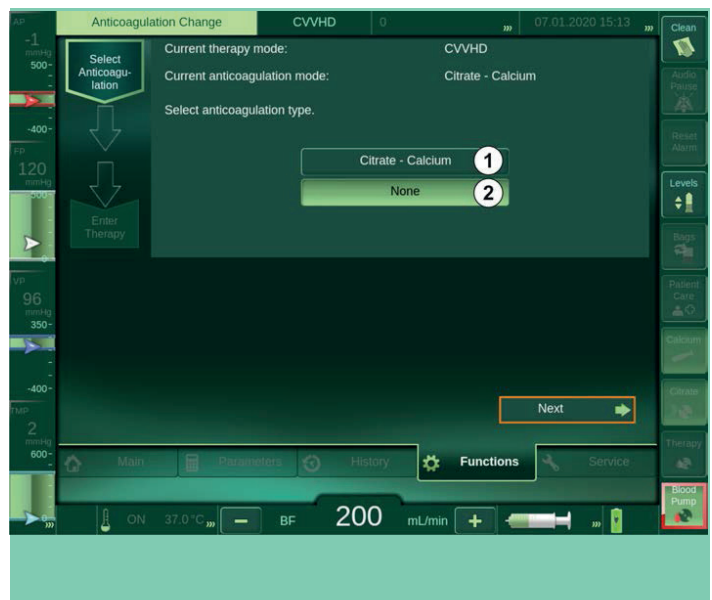

Make sure that the citrate and calcium lines are clamped, and the citrate bag and calcium syringe are removed.

- 6 Press next. The confirm new therapy parameters dialog is displayed. The parameters outlined in orange can be changed. Press confirm to continue therapy without anticoagulation.

Heparin anticoagulation can be started now. To set up this anticoagulation type, select functions and apply heparin anticoagulation on the menu bar and follow the instructions of the procedure.

6. During therapy

Adding anticoagulation to the therapy 6.2.19

When a therapy was started without anticoagulation, it is possible to subsequently add heparin anticoagulation to the therapy.

Adding anticoagulation to the therapy:

1 Select parameters > anticoagulation on the menu bar.

2 Press the apply heparin anticoagulation button ① on the anticoagulation screen.

The apply heparin anticoagulation screen appears.

3 Press the syringe type drop-down.

The list of supported syringe types opens.

4 Select the syringe type with the correct size that you want to use.

The filled volume field indicates the volume of the solution in the syringe.

5 Press the flow rate field.

The numeric keypad opens.

6 Enter the flow rate in mL/h and confirm the input with done.

7 Load heparin syringe.

8 Press confirm to return to the therapy.

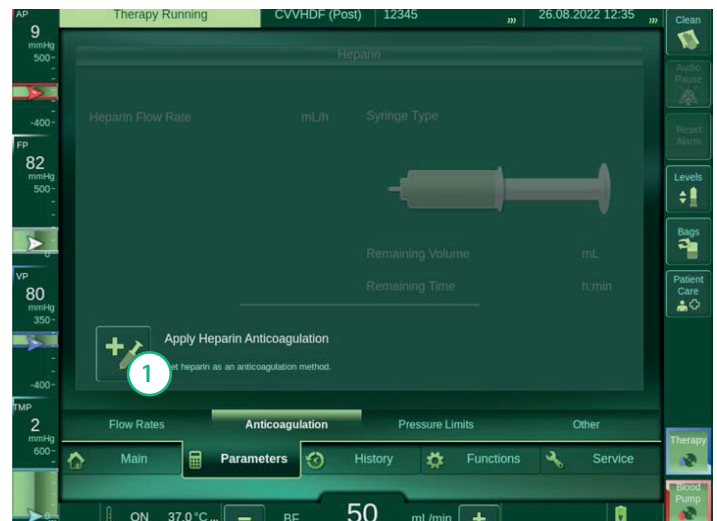

Key ① Apply Heparin Anticoagulation button

6.3 Blood return/end of therapy

A running therapy can be terminated any time. There are two different methods to end or interrupt the therapy. Use end therapy, the procedure described here, when the therapy is over, and the patient shall not be connected to the machine again. Use temporarily disconnect patient when the therapy is not over, and the patient is supposed to be reconnected to the machine after a short period of time.

Adding anticoagulation to the therapy:

- 1 Select functions ① on the menu bar.
- 2 Press the end therapy icon ② on the functions screen.
A confirmation prompt pops up: **Are you sure you want to end the therapy?**
- 3 Press yes to confirm your selection.
The return blood screen appears.



6.3 Blood return/end of therapy

How to return blood to the patient:

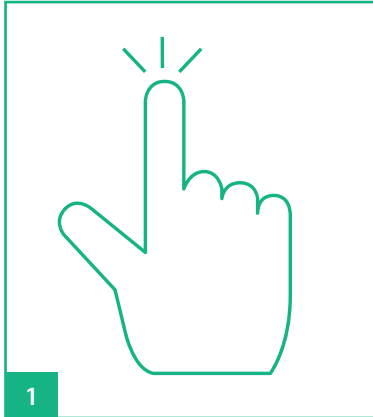

1

Select the return blood option.

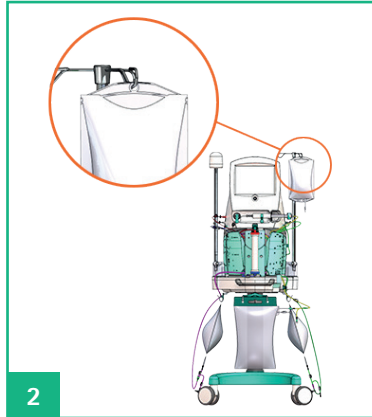

2

Hang a saline bag on the IV pole.

3 Connect arterial line (red) to saline bag and open clamps:

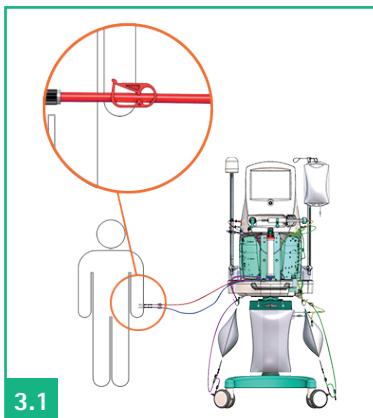

3.1

Close clamp on arterial line (red).

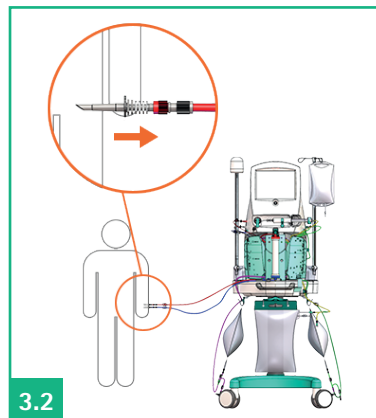

3.2

Safely remove the arterial line (red) from the patient access.

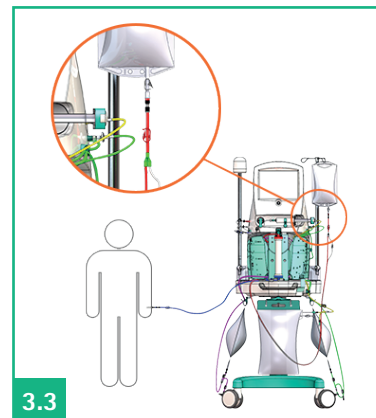

3.3

Connect arterial line (red) to saline bag.

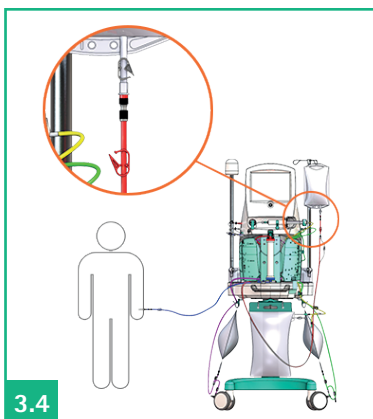

3.4

Open clamp on arterial line (red). If necessary, break the frangible pin in the bag outlet. Check bag connection, clamps and all lines for kinks.

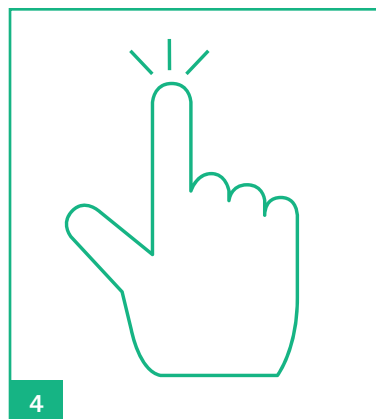

4

To start blood return, press the return blood button and monitor the blood lines.

4. The blood pump starts feeding back the blood volume set in the Return volume field. A progress bar indicates the amount of blood being returned.

The return volume can be set up to 500 mL when the blood pump is stopped. By default, the return volume is the nominal volume of the disposable kit.

The blood return will automatically stop once the return volume has been reached. Alternatively, it can be manually stopped at any time by releasing the return blood button.

5. Release the return blood button when the blood is returned or increase the volume, if necessary.

6. Return additional volume either by pressing the return +50 mL button or by adjusting the return volume parameter and pressing return blood. Blood return can be manually stopped at any time by releasing the return +50 mL button or the return blood button.

7. Disconnect venous line (blue) from patient:

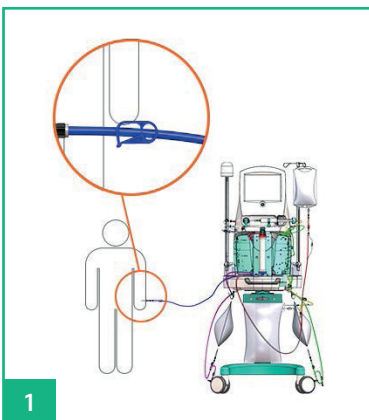

Close clamp on venous line (blue).

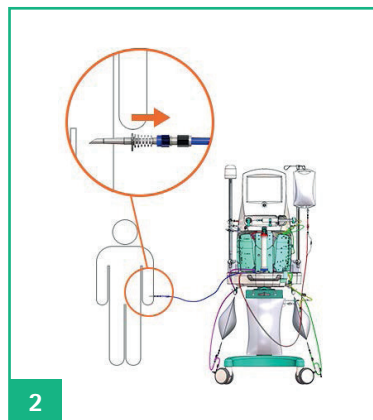

Safely remove the venous line (blue) from the patient access when the blood return is done.

7. Unloading disposables 6.3.4

Make sure that the patient has been disconnected from the machine.

Disconnect all bags:

- Clamp all lines and bags.
- Disconnect all lines from bags.

Remove the warmer bag:

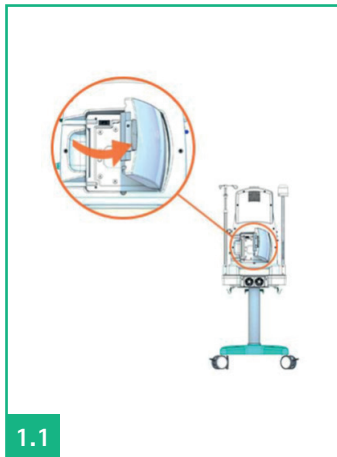

1.1

Open the warmer door. Release the locks on the fluid and blood side kit plates



1.2

Remove the line from the tube holders. Then press unload.

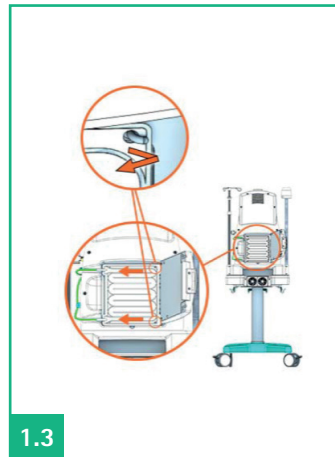

1.3

Remove the warmer bag from the two hooks at the door hinge.

Disconnecting the pressure lines

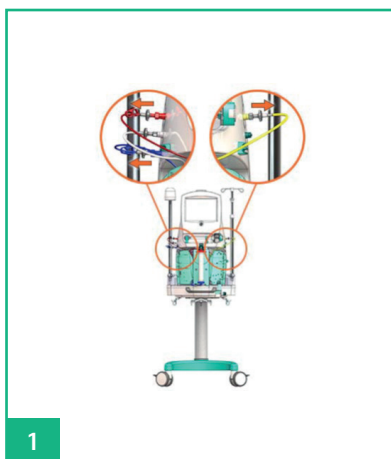

1

Disconnect the pressure lines from all pressure sensor connectors.

Automatic inloading of tube segments

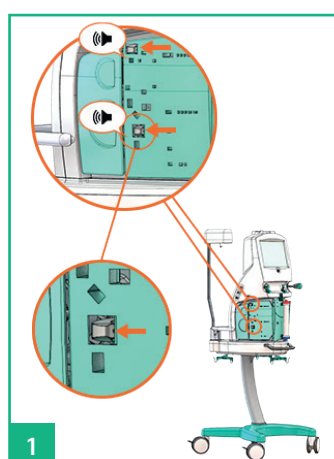

1

Press levers on both kit locks on the fluid and blood sides to release the kit.

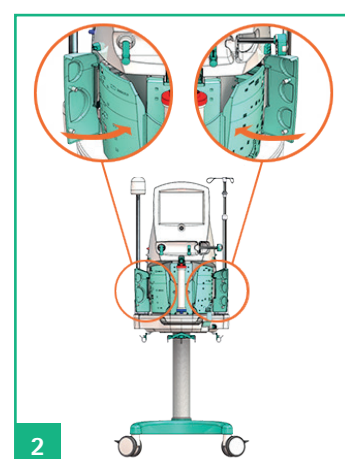

2

Start automatic unloading of the tube segments by pressing the unload button.

In case of unsuccessful unloading, make sure the blood and fluid side doors are closed then press unload again.

Detaching the disposable kit

Unload the kit from the machine. Detach the protective cover and save it for later use:

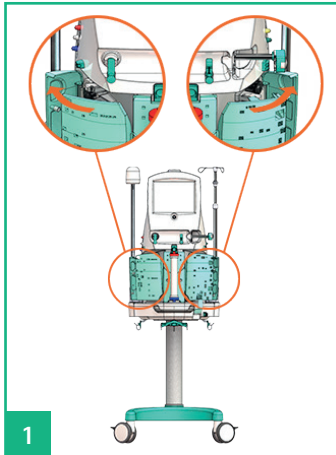

Open fluid and blood side doors.

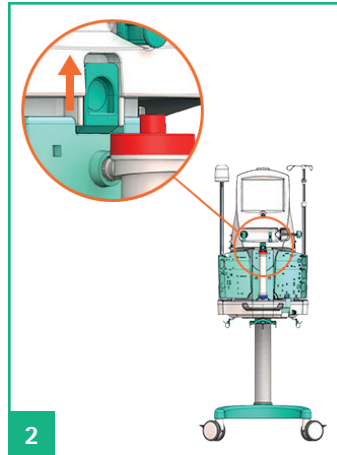

Release the kit by opening the latch at the top.

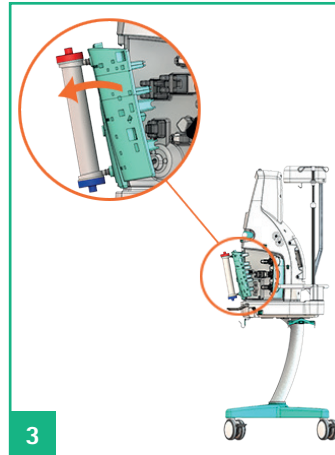

Remove the kit from the front of the machine.

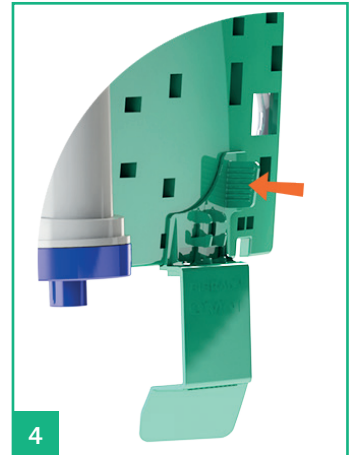

Detach the protective cover from the disposable kit, clean it and save it for later use.

8. Post treatment

Dispose of all used bags, syringes, and disposable kits as per facility protocol.

- The machine must be cleaned regularly.
- Refer to trust protocol for cleaning medical equipment after patient care.
- Ensure that no fluid enters the machine.
- Clean the machine and all non-single-use accessories.

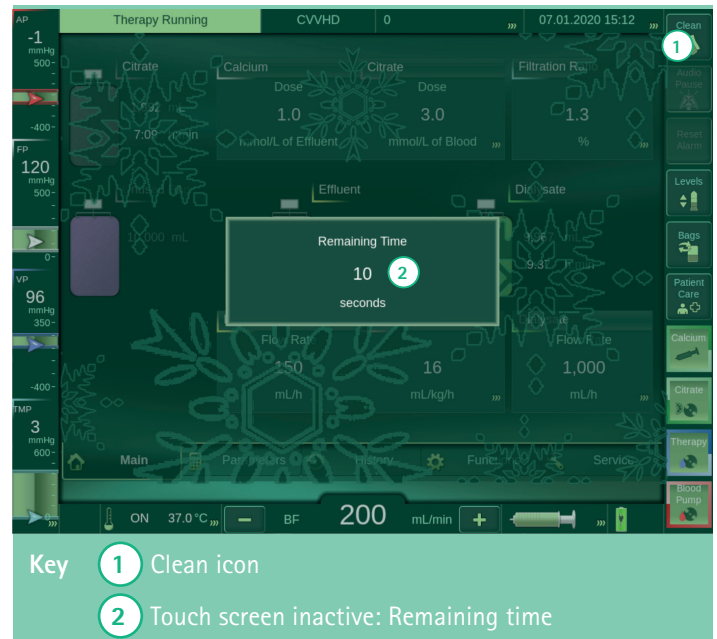

Note damage to the machine due to improper cleaning!

- Do not use abrasive substances or abrasive fibres for cleaning.
- Do not apply any disinfection spray inside the fan openings or any connectors on the rear side.
- Do not clean or disinfect the machine with anything exceeding a temperature of 50°C.
- The chemical compounds suitable for cleaning the machine are specified in cleaning agents for surface and screen disinfection and cleaning (IFU pg. 369).

