

Pumps: RCM 65-20B 2C15 U181 1

Item:

LIQUIDO

Liquid	WASTEWATER		Liquid Temperature	20	
Liquid			Density	1,00	kg/dm
Liquid	-		Kinematic Viscosity	1,0	mm2/

DESIGN PARAMETER

Working Capacity	50,0	m3/h	Working Absorbed Power	14,33	kW
Working Head	50,8	m	Nominal Working Speed	2.950	1/min
Required Capacity	50,0	m3/h	Service	-	
Required Head	50,8	m	Suction Conditions	-	
Min. Capacity	10,8	m3/h	Geodetic Suction Head	-	
Max. Capacity	98,0	m3/h	Gauge Suction Pressure	0,00	bar
Max. Head	55,0	m	Minimum ambient temperature	-20	°C
NPSH available	0,00	m	Altitude of Installation	<1000 m ASL	
NPSHr (Required from the pump)	3,22	m			
Efficiency at Working Point	48,3				

PUMP DETAILS

Pump Standard	ISO 5199		Pump Flanges Norm	EN 1092 PN10	
Pump Designation	RC		Rated Impeller Trim	B	
Pump Size	65-20		Impeller Type	Vortex	
Pump Group	2		Rated Impeller Diameter	195	mm
Installation area	Safe Area		Maximum Impeller Diameter	205	mm
GAS Atex Marking	-		Minimum Impeller Diameter	155	mm
DUST Atex Marking	-		Solids Free Passage [mm]	55	
Design Pressure	10	bar	Casing Drain Hole	Not Present	
Hydrostatic Test Pressure	15	bar	Casing Venting Hole	Not Present	
Suction Port Diameter [DN]	80		Painting Cycle	STD-RAL5010-Poliacr.cat.	
Discharge Port Diameter [DN]	65		Pump RAL	5010	

PUMPS EXECUTION

Pump Configuration	Horizontal		Pump Execution	Close Coupled	
--------------------	------------	--	----------------	---------------	--

PUMPS MATERIALS

Pump Casing Material	GJL 250 EN 1561		Wear Ring Material	Not Present	
Impeller Material	GJS 400 EN 1563		Lantern Bracket Material	EN1561 - GJL200	
Close Coupled Shaft Material	316L		Gasket Main Material	Guarnital	
Wear Plate Material	Not Present				

MECHANICAL SEALS

Seal Execution	U (Standard) (Single Seal)		API PLAN	Not Present	
Mechanical Seal Nominal Diamet	43	mm	Plan Pipes material	N.A.	
Seals Supply	Included		Flushing Pressure	Ext. Flushing not required	
Mech. Seal Type (Pump Side)	UN L4K		Flushing Tank Supply	Tank Not Included	
Mech. Seal Pump Side Brand	Uniten		Flushing Tank	Not Present	
MFR Internal Mech. Seals Code	181				
Mechanical Seal Pump Side	SIC/SIC/VITON				
Mech. Seal Pump Side Pin	Not Present				
Mech. Seal Type (Flush. Side)	-				
Mech. Seal Motor Side Brand	-				
Mechanical Seal Motor side	-				
Mech. Seal Motor Side Pin	Not Available				

EXTRA

Heating/Cooling Casing Chamber	Not Present		Pump Impeller Treatments	Not Present	
Seal Heating Jacket	Not Present		Special Pump Treatments	Not Present	
Heat Exchanger	Not Present		Special Casing Execution	Not Present	
Pump Casing Treatments	Not Present		AISI 304 Motor Shroud	Not Available	

MOTOR

Electric Motor Brand	WEG		Motor Class Tolerances	YES - Precision Class	
El. Motor Serie	W22		Additional Fan Cooling	-	
Electric Motor Poles	2		Motor Roof	-	
Motor Power	15,00	kW	PT100 Probes	-	
Motor Size	160M		Auxiliary Electric Box	-	
El. Motor Flange Diameter	350		Working Temp. < -20°C	-	
Electric Motor Supply	Included		Working Temp. >40°C	-	
El Motor Standard/Customized	Standard		Motor Casing Material	Cast Iron	
Motor Category	IEC (not Atex)		Downsized Motor	-	
Std. Electric Motor Brand	WEG		Derated Engine Power	-	kW
Nominal Motor Frequency	50	HZ	Additional Label	-	
Operating motor voltage	400/690		Insulated Ball Bearing for VFD	-	
Motor Efficiency Class	IE3		Motor Extras	-	
Motor Shape	B5		Extras	-	
Motor Protection	IP55		Extras	-	
Insulation Class	F		Extras	-	
PTC	Included		Extras	-	
Number of PTC Required	-				
Max Frequency (Inverter Use)	60				
Min. Frequency (Inverter Use)	30				

TEST AND CERTIFICATES

Food Certificate	No Certification Issue		NPSH Test	No Certification Issue	
ATEX Declaration of Conformity	No		Noise Test	No Certificate Issue	
Impeller Balancing Certificate	No Certificate Issue (P-1006)		Painting Check	No Certificate Issue	
CE Declaration of Conformity	Yes		Certificate of Quality	No	
Drawing Acc.To Customer Spec.	No		End Supply Certification Book	No	
Certificate of Warranty	No		Performance Test (Q-H-P)	No Certificate Issue	
Hydrostatic Test	No Certificate Issue (P-1005)		Visual a Dimensional Check	No Certificate Issue (P-1012)	
Inspection and Test Plan	No		Vibration Test	No Certificate Issue	
Material Certificate	-		Working Conformity Certificate	No Certification Issue	
Mechanical Running Test	No Certification Issue		Preferential Origin	Not Included	

CONFIDENTIAL AGREEMENT

NO PART OF THIS REPORT MAY BE REPRODUCED AND TRANSMITTED IN ANY FORM OR ANY MEANS WITHOUT PRIOR WRITTEN PERMISSION OF SR pumps.
THIS DOCUMENT MAY BE USED ONLY AS A PIECE OF CONFIDENTIAL TECHNICAL REFERENCE AND NEVER AS AN OFFICIAL DOCUMENT AGAINST SR pumps INTEREST.

NOTE:

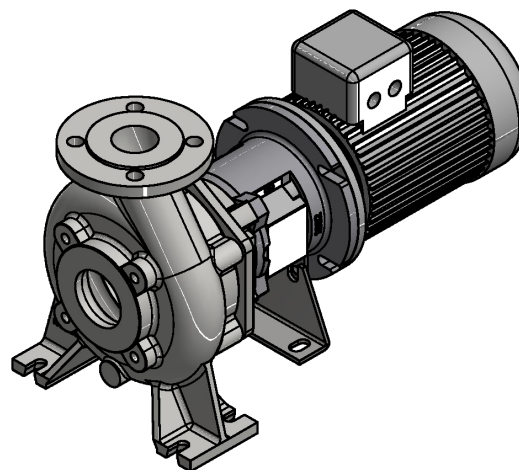
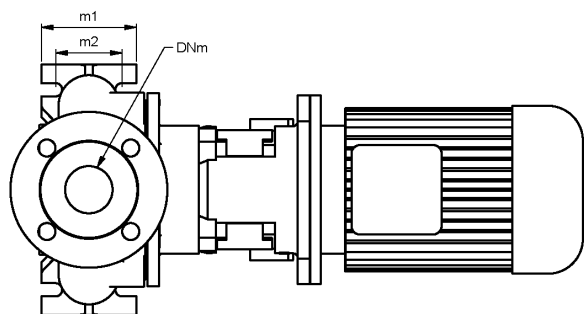
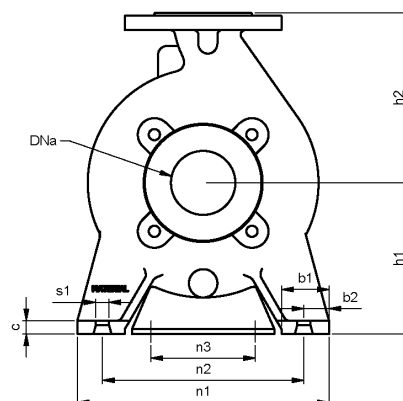
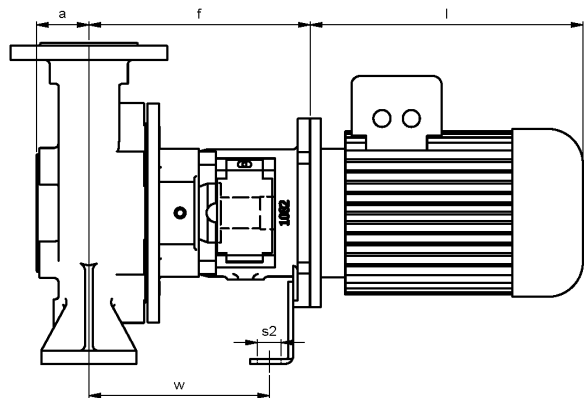

Serie	Taglia	Mot. Size	a	f	h1	h2	b	m1	m2	n1	n2	n3	w	s1	s2	c	c1	l1	l2	T(a)	Weight
RC	65-20	160M	66,00	339,00	180,00	225,00	65,00	125,00	95,00	320,00	250,00	212,00	287,00	14,00	19,00	16,00	0,00	150,50	150,50	1.060,0	216,00

(*) Lunghezza e peso possono variare in funzione della marca del motore
 (*) Length and weight may vary, it depends by the motor brand

Ref.Speed (rpm) 2.950

ITEM: R

Curve n.: T-1070	Max Diameter (mm): 205	Min Diameter (mm): 155	Sel. Diameter (mm): 195	Material: CAST IRON			
Flow (m3/h): 50,00000	Head (m): 50,780000	Power (kW): 14,330000	Efficiency (%): 48,2800	NPSH (m) 3,220000	NS: 22	SSS: 147	GD2: 0
Density (kg/dm3): 1,00000	Viscosity (cSt): 1,0000000	Fluid: Non Specificato	Impeller Type: VORTEX				

