

PART OF THE
TECHNICAL DOCUMENTATION

PRODUCT DESCRIPTION
**ACS[®] UNI / PB UNI KNEE
SYSTEM**

PRODUCT-GROUP: UNICONDYLAR KNEE
ARTHROPLASTY

RISK-CLASS: III

LOCATION: KNEE

DATE: 05.11.2020, REV. 1

TABLE OF CONTENTS

1. ACS® Uni / PB Uni Knee System	4
2. Intended Use	5
3. Qualification of the Product as a Medical Device	5
4. Risk-class: III	6
5. Intended User	6
6. Target Group	6
7. Indications	6
8. Contraindications	6
9. Risk Factors	6
10. Design Description	7
10.1. Femoral Components	7
10.1.1. ACS® Uni Femoral Component	7
10.1.2. PB Uni Femoral Component	7
10.2. Tibial Components	8
10.2.1. ACS® Uni Tibial Component	8
10.2.2. Uni FB Tibial Component	8
10.2.3. PB Uni PE Tibial Component	9
10.3. PE-Inserts	10
10.3.1. ACS® Uni PE-Insert	10
10.3.2. Uni FB PE-Insert	10
11. Materials	10
12. Coatings / Surfaces	11
13. Sizes and Dimensions	12
13.1. Femoral Components	12
13.2. Tibial Component	13
13.3. PE-Inserts	14
14. Compatibility	15
14.1. Femoral Component – PE-Insert	16
14.2. Tibial Component – PE-Insert	16
14.3. Femoral Component – PE Tibial Component	16
15. Warnings	16
16. Product List (Identification of the products)	16



17. Reference to Previous Generations and Similar Devices	16
LIST OF FIGURES.....	17
LIST OF TABLES	17
LIST OF ABBREVIATIONS	18
DOCUMENT REVISION HISTORY.....	19



1. ACS® Uni / PB Uni Knee System

The ACS® Uni / PB Uni System is a unicondylar knee system which enables the minimally-invasive replacement of the articulating surface of one condyle.

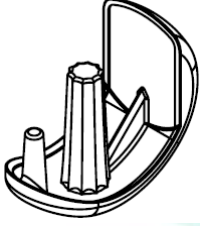
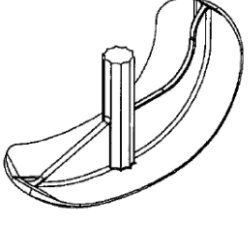
The system is available in FB (fixed bearing) and MB (mobile bearing) versions.

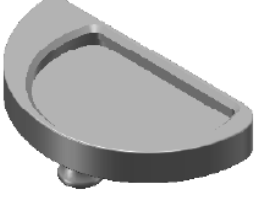
ACS® Uni / PB Uni Knee System					
FEMORAL COMPONENT					
ACS® Uni femoral component		 <p>FIG. 1: ACS® Uni Femoral Component</p>			
cemented or cementless					
coated (TiN)	uncoated (LD ¹)				
sizes 1 - 4					
PB Uni femoral component		 <p>FIG. 2: PB Uni Femoral Component</p>			
cemented					
coated (TiN)	uncoated (LD)				
LL/RM ²	LM/RL ³			LL/RM	LM/RL
sizes 1 - 4					
TIBIAL COMPONENT					
ACS® Uni tibial component		 <p>FIG. 3: ACS® Uni Tibial Component</p>			
cemented or cementless					
coated (TiN)	uncoated (LD)				
sizes 1 - 8					
Uni FB tibial component		 <p>FIG. 4: Uni FB Tibial Component</p>			
cemented					
LM/RL	LM/RL				
sizes 0 – 4, 2S, 3S					

¹ LD: low demand

² left lateral / right medial

³ left medial / right lateral

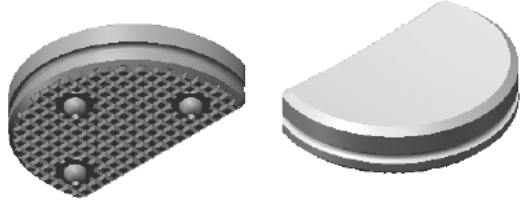
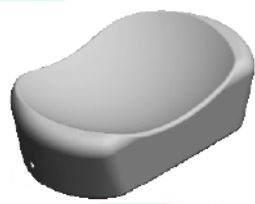
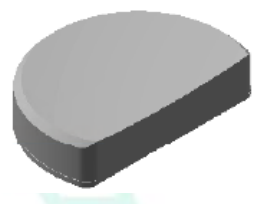
PB Uni PE tibial component		 <p>FIG. 5: PB Uni PE Tibial Component</p>
cemented		
sizes 1 – 4, 1,5, 2,5 / 6,5mm, 7,5mm, 8,5mm, 9,5mm		
PE-INSERT		
ACS® Uni PE-insert		 <p>FIG. 6: ACS® Uni PE-Insert</p>
UHMWPE		
sizes 1 - 4 / 4mm, 5mm, 6mm, 7mm, 8mm, 9mm, 10mm, 11mm, 12mm		
Uni FB PE-insert		 <p>FIG. 7: Uni FB PE-Insert</p>
UHMWPE	implacross® E	
sizes 0 - 4 / 8mm, 9mm, 10mm, 11mm, 12mm, 14mm		

2. Intended Use

⇒ See Doc. „Fbl_423-1-2-4_Zweckbestimmung_ACS® Uni - PB Uni” in the folder “03 Produktbeschreibung”

3. Qualification of the Product as a Medical Device

The products of the ACS® Uni / PB Uni Knee System are medical devices in accordance with the Council Directive 93/42/EEC and the Definitions in Article 2 of the Medical Device Regulations MDR (EU) 2017/745 of 05. April 2017. The products of the ACS® Uni / PB Uni Knee System are “medical devices” “for human beings for the specific medical purposes” as described in the Article 2 under (1) of the of the Medical Device Regulations MDR (EU) 2017/745 of 05. April 2017.

4. Risk-class: III

The products of the ACS® Uni / PB Uni Knee System are classified in risk class III in accordance with the classification rules in Annex VIII of the Medical Device Regulations MDR (EU) 2017/745 of 05. April 2017. The risk class is justified as the products of the ACS® Uni / PB Uni Knee System meet the Rule 8 in 5.4 of the Medical Device Regulations MDR (EU) 2017/745 that they are partial joint replacement.

5. Intended User

The use of this implant is restricted to persons who, based on their education, knowledge and practical experience, are capable of proper handling and use of the device. Familiarity with the recommended surgical technique and its careful application as well as a pre-operative planning are essential to achieve the best possible outcome. The implantcast GmbH offers special user trainings to ensure an optimal preparation.

6. Target Group

The target population corresponds to the population likely to benefit from the product in indication for joint replacement. Finally, the surgeon decides whether and which version of prosthesis for the individual patient is suitable. This decision depends on several factors, such as the age and the patient's weight, bone quality, shape of the bone, patient's physical activity levels and deformation of the joint. The provision of prostheses is generally indicated only in patients whose skeleton is fully grown.

7. Indications

⇒ See Doc. "09300026 ACS Uni - PB Uni" in the folder "04 Gebrauchsinformation"

8. Contraindications

⇒ See Doc. "09300026 ACS Uni - PB Uni" in the folder "04 Gebrauchsinformation"

9. Risk Factors

⇒ See Doc. "09300026 ACS Uni - PB Uni" in the folder "04 Gebrauchsinformation"

10. Design Description

10.1. Femoral Components

10.1.1. ACS® Uni Femoral Component

The femoral component features a symmetric design, so that a both sided use is possible. Two femoral pegs ensure high rotational stability. The dorsal fin behind the second peg stabilizes the implant against rotational torque. The contour of the femoral component contributes to a maximum preservation of bone stock.



FIG. 8: ACS® Uni Femoral Component Cemented (TiN coated) FIG. 9: ACS® Uni Femoral Component Cementless (TiN Coated)

The articulating surfaces of the ACS® Uni femoral components feature a multi-radius design (J-curve profile). This design gives the femoral component an anatomical fit and allows a kinematic function of the knee joint, which is related to the physiological knee motion.



FIG. 10: ACS® Uni Femoral Component in Combination With ACS® Uni Tibial Component (Both TiN Coated) and ACS® PE-Insert (Left: Rear View; Right: Side View)

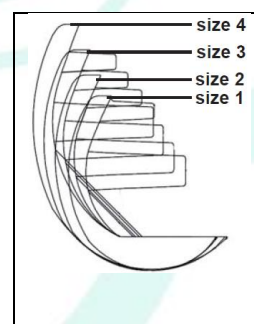

FIG. 11: ACS® Uni Femoral Component - Sizes

10.1.2. PB Uni Femoral Component

The PB Uni femoral component is intended for cemented anchoring and features an asymmetric shape for an optimal anatomical fit on either the right medial / left lateral (RM/LL) or the left medial / right lateral (LM/RL) side. The femoral peg and the dorsal fin ensure rotational stability.



FIG. 12: PB Uni Femoral Component (Left: Uncoated; Right: TiN Coated)

10.2. Tibial Components

10.2.1. ACS® Uni Tibial Component

The ACS® Uni tibial component features a mobile bearing symmetric design, so that a both sided use is possible. The tibial fin ensures high rotational stability. The contour allows a good bone coverage. The ACS® Uni tibial component is available in cemented and cementless versions.



FIG. 13: ACS® Uni Tibial Component Cemented (TiN Coated)



FIG. 14: ACS® Uni Tibial Component Cementless (TiN Coated)

10.2.2. Uni FB Tibial Component

The Uni FB tibial components are metal backed fixed bearing tibial implants in an asymmetrical shape for an optimal anatomical fit on either the right medial / left lateral (RM/LL) or the left medial / right lateral (LM/RL) side.

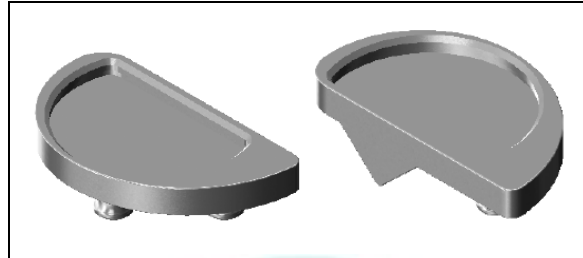

FIG. 15: Uni FB Tibial Component (Left: LM/RL; Right: LL/RM)

Due to the contour of the tibial component an optimal bone coverage is achieved with a minimal amount of bone resection. The component is designed for cementation, one fin and two pegs ensure optimal rotation stability (FIG. 16).



FIG. 16: Uni FB Tibial Component - Fin and Pegs

10.2.3. PB Uni PE Tibial Component

The fixed bearing all-poly PB Uni PE tibial component features a nearly flat design (single radius) and has a symmetrical shape for use on both sides. The component is intended for cemented implantation. To optimize fixation in bone cement the underside is textured with vertical and horizontal ribs. Additionally, it features three anchoring feet. The components provide a x-ray marker wire made of TiAl₆V₄ acc. to ISO 5832-3.

During implantation of the PB Uni PE tibial component, the tibial bone is reamed out, thereby preserving the cortical of the affected tibial condyle. Thus, the tibial component is embedded in the bone.

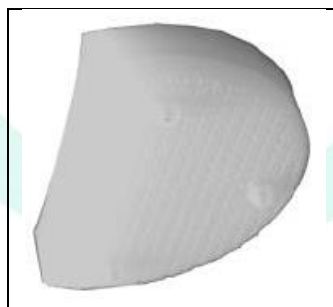

FIG. 17: PB Uni PE Tibial Component

10.3. PE-Inserts

10.3.1. ACS[®] Uni PE-Insert

The mobile bearing ACS[®] Uni PE-inserts are symmetric and freely moveable on the tibial component. The concave formed bearing surface ensures a high congruency to the tread of the femoral component. The ACS[®] Uni PE-inserts contain contrast wire for x-ray visibility.



FIG. 18: ACS[®] Uni PE-Insert

10.3.2. Uni FB PE-Insert

The fixed bearing Uni FB PE-inserts have a symmetrical shape for use on both sides. The bearing surface provides a low congruency to the tread of the femoral component.

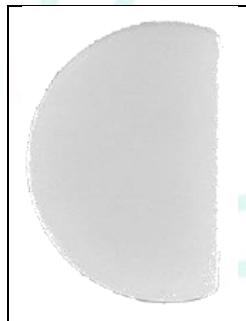

FIG. 19: Uni FB PE-Insert

11. Materials

The ACS[®] Uni and PB Uni femoral components are manufactured from CoCrMo acc. to ISO 5832-4.

The ACS[®] Uni tibial component is manufactured from CoCrMo acc. to ISO 5832-4. The Uni FB tibial component is manufactured from TiAl₆V₄ acc. to ISO 5832-3. The PB Uni PE tibial component is manufactured from UHMWPE acc. to ISO 5834-2. The contrast pins for x-ray visibility are made of TiAl₆V₄ acc. to ISO 5832-3.

Uni FB PE-inserts are manufactured from UHMWPE acc. to ISO 5834-2 and are also available in crosslinked UHMWPE doped with 1000ppm vitamin E. The ACS[®] Uni PE-inserts are manufactured

from UHMWPE acc. to ISO 5834-2. The contrast wire for x-ray visibility is made of TiAl₆V₄ acc. to ISO 5832-3.

12. Coatings / Surfaces

All ACS® Uni and PB Uni femoral components are available with and without TiN coating. The articulating surface is highly polished.

The ACS® Uni femoral components cemented have a 0.3 mm deep cement pocket and a sandblasted inner contour. The inner contour of the PB Uni femoral component is sandblasted, too. The ACS® Uni femoral components cementless provide a plasma sprayed coating of commercially pure titanium (cpTi) acc. to ISO 5832-2 on the inner part to attain a rough and porous surface for mechanical anchorage.

All ACS® Uni tibial components have a highly polished articulating surface and provide a TiN coating as standard version. Non coated components (LD) are also available. The cemented versions have a 0.3 mm deep cement pocket and a sandblasted inner contour. The cementless version provides a plasma sprayed coating of commercially pure titanium (cpTi) acc. to ISO 5832-2 on the inner part to attain a rough and porous surface for mechanical anchorage.

The upper side of the Uni FB tibial component is highly polished. To optimize fixation in bone cement the underside is roughened by corundum blasting.

CHARACTERISTICS	VALUE	
	TiN	cpTi
COATING THICKNESS	5.5 ± 1.5 µm	300 ± 50 µm
POROSITY	/	30 ± 10 %
AVERAGE ROUGHNESS Ra	< 0.05 µm	50 ± 15 µm
AVERAGE ROUGHNESS Rt	/	/
TENSILE STRENGTH	≥ 22 MPa	> 22 MPa
SHEAR STRENGTH	/	> 20 MPa
CaP – RATIO	/	/

TAB. 1: Coating Specifications for TiN and cpTi

The upper side and outer contour of the PB Uni PE tibial component have a roughness Ra of 1.6 µm. The underside is textured with vertical and horizontal ribs.

The ACS® Uni PE-inserts have a roughness Ra of 2 µm. The articulating surface of the Uni FB PE-inserts have a roughness Ra of 1.6 µm.

13. Sizes and Dimensions

13.1. Femoral Components

The ACS® Uni femoral component is available in four sizes.

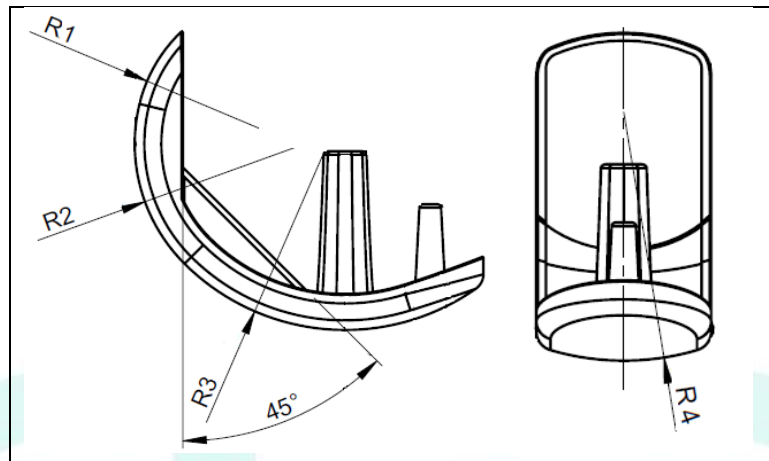

FIG. 20: ACS® Uni Femoral Component - Dimensions

	SIZE			
	1	2	3	4
R1 [mm]	14	16	18	21
R2 [mm]	17	19	21	24
R3 [mm]	21	24	28	32
R4 [mm]	21	24	28	32
Width [mm]	18	20	21	22

TAB. 2: ACS® Uni Femoral Component - Dimensions

The PB Uni femoral component is available in two configurations: right medial / left lateral (RM/LL) and left medial / right lateral (LM/RL). Each configuration comes in four sizes.

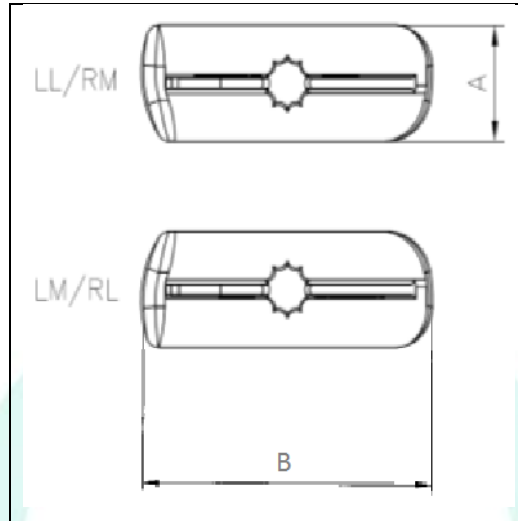

FIG. 21: PB Uni Femoral Component - Dimensions

	Size (RM/LL and LM/RL)			
	1	2	3	4
A (Width) [mm]	15	17	19	21
B (Length) [mm]	46	49	55	60

TAB. 3: PB Uni Femoral Component - Dimensions

13.2. Tibial Component

The ACS® Uni tibial component is available in 8 sizes with a thickness of 2.7 mm for all sizes.

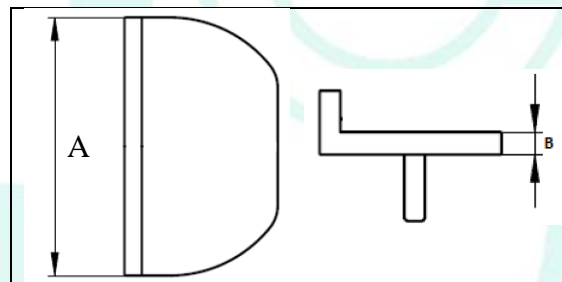

FIG. 22: ACS® Uni Tibial Component - Dimensions

	Size							
	1	2	3	4	5	6	7	8
Length (A) [mm]	37	40	43	46	49	52	55	58
Thickness (B) [mm]	2.7	2.7	2.7	2.7	2.7	2.7	2.7	2.7

TAB. 4: ACS® Uni Tibial Component - Dimensions

The Uni FB tibial component is available in two configurations: right medial / left lateral (RM/LL) and left medial / right lateral (LM/RL). Each configuration comes in seven sizes from 0 to 4 with intermediate sizes 2S and 3S.

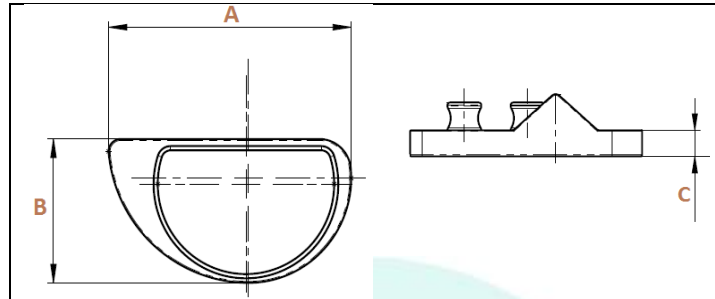

FIG. 23: Uni FB Tibial Component - Dimensions

	Size (RM/LL and LM/RL)						
	0	1	2	2S	3	3S	4
A (Length) [mm]	41	44	50	47	55	54	59
B (Width) [mm]	23	26	29	28	32	31	34
C (Thickness) [mm]	5.2	5.2	5.2	5.2	5.2	5.2	5.2

TAB. 5: Uni FB Tibial Component - Dimensions

The PB Uni PE tibial component is available in six sizes with four different thicknesses.

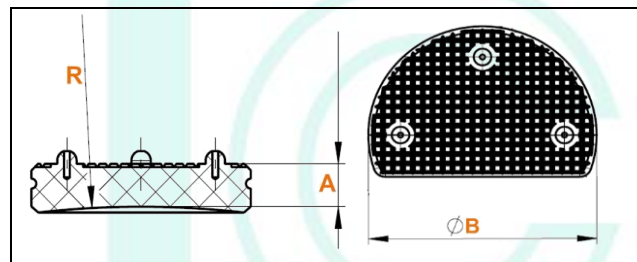

FIG. 24: PB Uni PE Tibial Component - Dimensions

	Size					
	1	1,5	2	2,5	3	4
A (Thickness) [mm]	6.5					
	7.5					
	8.5					
	9.5					
B (Diameter) [mm]	32	34	37	39	41	44
R (Radius) [mm]	128.5	145.0	171.6	190.6	210.6	242.5

TAB. 6: PB Uni PE Tibial Component - Dimensions

13.3. PE-Inserts

The ACS® Uni PE-inserts are available in four sizes and 9 heights from 4mm to 12mm (in 1 mm steps).

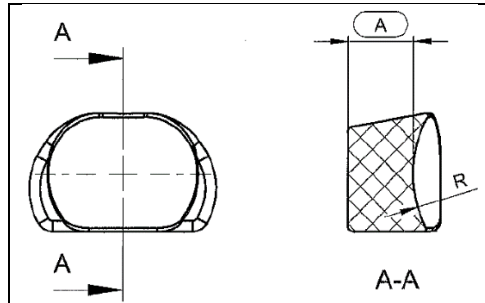

FIG. 25: ACS® Uni PE-Insert - Dimensions

	Size			
	1	2	3	4
R [mm]	21	24	28	32

TAB. 7: ACS® Uni PE-Insert - Dimensions

The Uni FB PE-inserts are available in five sizes and six heights from 8 mm to 14 mm (in 1 mm steps, except 13 mm).

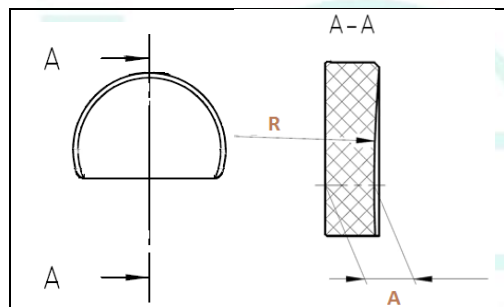

FIG. 26: Uni FB PE-Insert - Dimensions

	Size				
	0	1	2	3	4
R [mm]	128.5	128.5	171.6	210.6	242.5

	Size					
	8mm	9mm	10mm	11mm	12mm	14mm
A (Thickness) [mm]	5.8	6.8	7.8	8.8	9.8	11.8

TAB. 8: Uni FB PE-Insert - Dimensions

14. Compatibility

The detailed component compatibility is given in the tables of combination.

- ⇒ See Doc. „Kombitabelle_ACS Uni - PB Uni_Femur - PE-Einsatz“, „Kombitabelle_ACS Uni - PB Uni_Femur - PE-Tibia“ and „Kombitabelle_ACS Uni - PB Uni_Tibia - PE-Einsatz“ in folder “12 Kombinationstabellen”

The components of the ACS® Uni / PB Uni Knee System are fully compatible and may only be used or combined with each other. Combinations with components from other manufacturers is not permitted.

14.1. Femoral Component – PE-Insert

The ACS® Uni PE-inserts are compatible with the ACS® Uni femoral components of the identical size. The Uni FB PE-inserts are compatible with ACS® Uni and PB Uni femoral components regardless of size.

14.2. Tibial Component – PE-Insert

The ACS® Uni PE-inserts are compatible with the ACS® Uni tibial components of the identical size and all bigger sizes.

The Uni FB PE-inserts are compatible with the Uni FB tibial components of the identical size (tibial component size 2S ↔ PE-insert size 2, 3S ↔ 3).

14.3. Femoral Component – PE Tibial Component

The PB Uni PE tibial components are compatible with all sizes of the PB Uni femoral components.

15. Warnings

⇒ See Doc. “09300026 ACS Uni - PB Uni” in the folder “04 Gebrauchsinformation”

16. Product List (Identification of the products)

For identification of the products by their respective number, please refer to the product list.

⇒ See Doc. “Fbl_732-1-0-14_Produktliste_ACS Uni - PB Uni” in the folder “01 Produktliste”

17. Reference to Previous Generations and Similar Devices

The ACS® Uni / PB Uni Knee System is a fusion of the ACS® Uni and PB Uni Knee Systems.

Similar devices available on the market are the Repicci II® from the company Biomet Inc. and Uniglide™ from the company Corin Inc..

LISTS

LIST OF FIGURES

FIG. 1: ACS® Uni Femoral Component	4
FIG. 2: PB Uni Femoral Component	4
FIG. 3: ACS® Uni Tibial Component.....	4
FIG. 4: Uni FB Tibial Component	4
FIG. 5: PB Uni PE Tibial Component	5
FIG. 6: ACS® Uni PE-Insert	5
FIG. 7: Uni FB PE-Insert.....	5
FIG. 8: ACS® Uni Femoral Component Cemented (TiN coated)	7
FIG. 9: ACS® Uni Femoral Component Cementless (TiN Coated)	7
FIG. 10: ACS® Uni Femoral Component in Combination With ACS® Uni Tibial Component (Both TiN Coated) and ACS® PE-Insert (Left: Rear View; Right: Side View)	7
FIG. 11: ACS® Uni Femoral Component - Sizes	7
FIG. 12: PB Uni Femoral Component (Left: Uncoated; Right: TiN Coated).....	8
FIG. 13: ACS® Uni Tibial Component Cemented (TiN Coated)	8
FIG. 14: ACS® Uni Tibial Component Cementless (TiN Coated)	8
FIG. 15: Uni FB Tibial Component (Left: LM/RL; Right: LL/RM)	9
FIG. 16: Uni FB Tibial Component - Fin and Pegs.....	9
FIG. 17: PB Uni PE Tibial Component	9
FIG. 18: ACS® Uni PE-Insert	10
FIG. 19: Uni FB PE-Insert.....	10
FIG. 20: ACS® Uni Femoral Component - Dimensions	12
FIG. 21: PB Uni Femoral Component - Dimensions	13
FIG. 22: ACS® Uni Tibial Component - Dimensions.....	13
FIG. 23: Uni FB Tibial Component - Dimensions	14
FIG. 24: PB Uni PE Tibial Component - Dimensions	14
FIG. 25: ACS® Uni PE-Insert - Dimensions.....	15
FIG. 26: Uni FB PE-Insert - Dimensions	15

LIST OF TABLES

TAB. 1: Coating Specifications for TiN and cpTi	11
TAB. 2: ACS® Uni Femoral Component - Dimensions	12
TAB. 3: PB Uni Femoral Component - Dimensions	13
TAB. 4: ACS® Uni Tibial Component - Dimensions.....	13
TAB. 5: Uni FB Tibial Component - Dimensions	14
TAB. 6: PB Uni PE Tibial Component - Dimensions	14
TAB. 7: ACS® Uni PE-Insert - Dimensions.....	15
TAB. 8: Uni FB PE-Insert - Dimensions	15
TAB. 9: List of Abbreviations	18

LIST OF ABBREVIATIONS

ABBREVIATION	ABBREVIATED TERM
FB	fixed bearing
LD	low demand
LL/RM	left lateral / right medial
LM/RL	left medial / right lateral
MB	mobile bearing

TAB. 9: List of Abbreviations

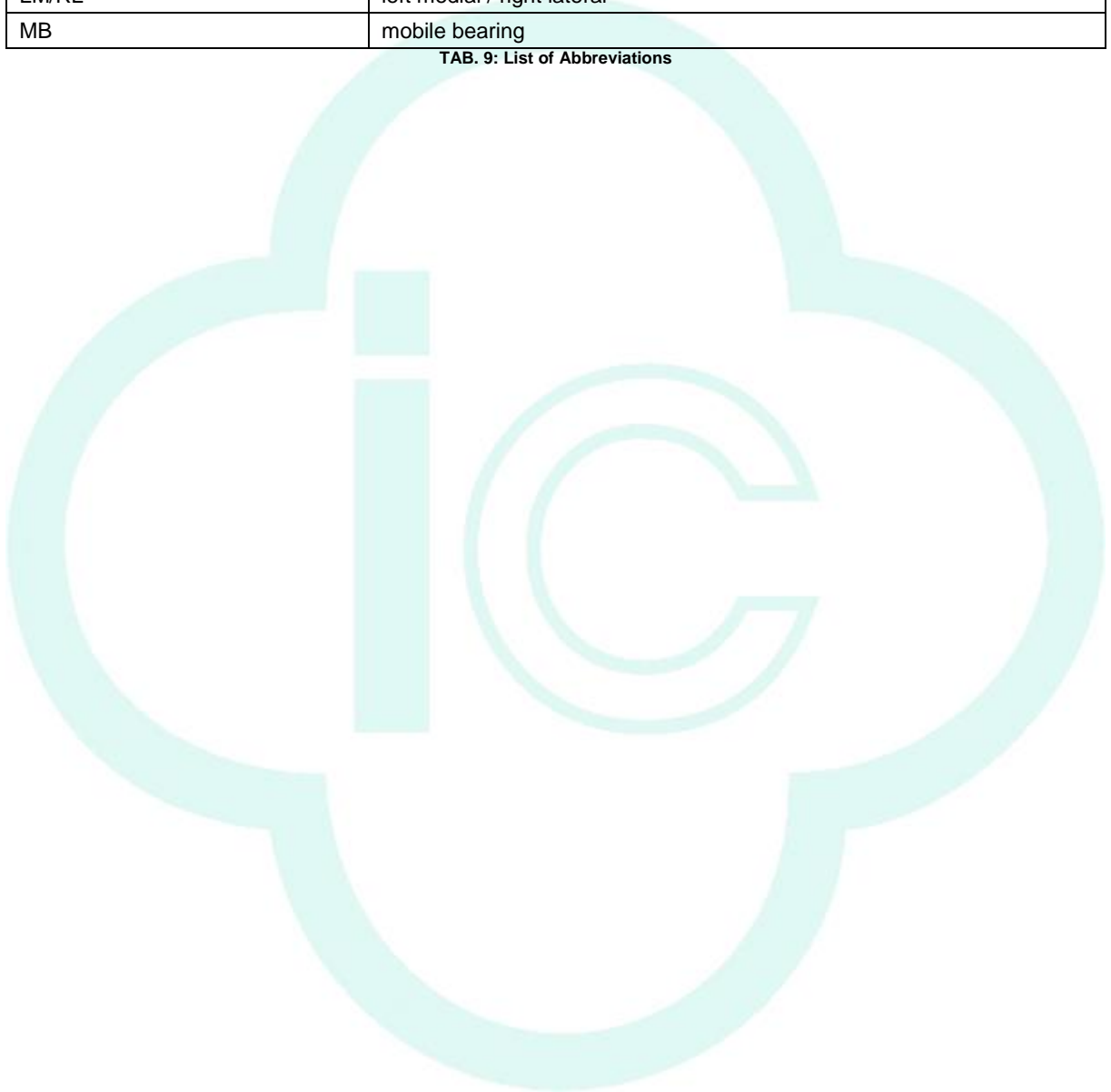

DOCUMENT REVISION HISTORY

DATE	REVISION	CHANGES	AUTHOR	COMMENTS
28.08.2020	0	Creation	N. Kapitonov	Merging of systems ACS® Uni and PB Uni
05.11.2020	1	Change of the chapters <i>03. Qualification of the Product as a Medical Device, 04. Risk Class III and 14. Compatibility</i>	N. Kapitonov	chapters 03 und 04 → conversion to MDR; chapter 14 → correction of the item descriptions ÄA 20-856

