

Lot 109, Hotă cu flux laminar**Model propus: MN 120, Nuve, Turcia**

Parametri solicitati	Parametri oferiti
<p>Hotă cu flux laminar Cod 250100 Descriere Dulapuri biologice de siguranță care cuprind clasa II, folosite pentru ventilare în laboratorul clinic. Excluce clasa I, clasa a III, și hote cu flux orizontal, precum și hote chimice și debitul de aer laminar banci curate. Parametru Specificație Descriere Hotă microbiologică cu flux laminar vertical, clasa II tip A2 Control controlat de microprocesor sensor volumetric pentru monitorizarea fluxului de aer epuizat control automat al volumului de flux prezentat Interior suprafața internă din oțel inoxidabil antistatic Filtre HEPA sau ULPA Prefiltru Eficiența de minim 85 %, pentru particule de minim 0.5 microni, clasa G4 Lumina interioară lumină rece, integrată, cu intensitatea de minim 800 lux lampa UV pentru sterilizare, fixată în vitrina frontală Nivelul de zgomot 60dB ≤ Flux aer > 0.4 m/s Factorul de protecție (Apf) 1.5 10⁵ Afijaj digital Alimentarea 220V, 50 Hz Alarmer Acustică Vizuală Capac de închidere a exhaustării obligatoriu Set de livrare Hota cu filtre Lampă de iluminare lampă UV suport pentru amplasarea hotei robinet pentru vacuum robinet pentru gaze</p>	<p>Hotă cu flux laminar Cod 250100 Descriere Dulapuri biologice de siguranță care cuprind clasa II, folosite pentru ventilare în laboratorul clinic. Excluce clasa I, clasa a III, și hote cu flux orizontal, precum și hote chimice și debitul de aer laminar banci curate. Parametru Specificație Descriere Hotă microbiologică cu flux laminar vertical, clasa II tip A2 Control controlat de microprocesor sensor volumetric pentru monitorizarea fluxului de aer epuizat control automat al volumului de flux prezentat Interior suprafața internă din oțel inoxidabil antistatic Filtre HEPA Prefiltru Eficiența de minim 85 %, pentru particule de minim 0.5 microni, clasa G4 Lumina interioară lumină rece, integrată, cu intensitatea de minim 800 lux lampa UV pentru sterilizare, fixată în vitrina frontală Nivelul de zgomot 60dB ≤ Flux aer > 0.4 m/s Factorul de protecție (Apf) 1.5 10⁵ Afijaj digital Alimentarea 220V, 50 Hz Alarmer Acustică Vizuală Capac de închidere a exhaustării obligatoriu Set de livrare Hota cu filtre Lampă de iluminare lampă UV suport pentru amplasarea hotei robinet pentru vacuum robinet pentru gaze</p>



MN SERIES

Microbiological Safety Cabinets





Ensuring first class protection for operator, environment and product, MN Series Class II Microbiological Safety Cabinets are the instrument of choice when handling microorganism which are potentially hazardous, hazardous or whose hazard level is unknown.

CAREFULLY DESIGNED BODY

- Outer body made of epoxy-polyester powder coated steel
- Stainless steel working table as three pieces for easy cleaning and decontamination
- Laminated glass window resisting UV lights
- Partially recirculated HEPA filtered air to prolong the lifetime of HEPA filters

SAFETY OVER STANDARDS

- Reliable microprocessor control system for safe operations
- Continuously controlled airflow speed which is always kept at $0,40 \pm 20\%$ m/sec
- Automatic speed compensation system against clogged HEPA filters
- Large LED display to follow airflow speed easily
- Advanced audible and visible alarm system for :
 - Low or high airflow speed
 - Power failure
 - Open window
 - Fan motor failure
 - Main PCB failure
 - Speed sensor failure
 - Low air intake airflow
- Fixed height of front opening to prevent contamination by excessive opening of the window
- Gas spring assisted window compressing to the seal for perfect air tightness
- No risk of wearing out of the window seal because of a sliding window
- Front enclosure with UV light for perfect decontamination of working table without disturbing laminar airflow during operation
- Separate hour counters for the UV light operation and filter life
- Key operated power switch to prevent against unauthorized use





SIMPLICITY OF USAGE

- No need for any adjustment due to the advanced microprocessor control system
- Easy to use control panel including keys and alarm LEDs for the functions of the cabinet
- Control of UV light automatically for a duration of 15 minutes

COMFORT FOR THE OPERATIONS

- Low noise level by means of very silent blower and plenum design
- The lamp placed outside the cabinet not to disturb laminar airflow
- Powerful glare-free lighting
- No harsh reflection due to white interior surface
- The limited depth allowing the cabinets pass easily from the entrance of the laboratories for easy installation



EASE OF MAINTENANCE

- Smooth chamber walls and rounded corners for easy decontamination and cleaning
- White epoxy-polyester powder coated walls resisting decontamination reagents and UV light
- Fully opened window for easy decontamination and cleaning of the interior of window without spending time and effort
- Easy access to main and exhaust filter for replacement
- Electronic control system placed outside of the contaminated zone for easy servicing

TECHNICAL SPECIFICATIONS

	MN 090	MN 120*
HEPA Filters	99,999% Efficiency for Particles $\geq 0,3\mu\text{m}$ (H14 class according to EN 1822)	
Cabinet	Epoxy Polyester Painted Cold Rolled Steel Sheet (2 mm.)	
Working Table	304 Stainless Steel	
Airflow Speed Control	Microprocessor Control System with LED Display and Automatic Speed Compensation for increasing Filter Resistance	
Blower	High Efficiency Centrifugal Type with Lifetime Lubricated Bearings	
Light	High Efficiency, Low Voltage ≥ 1.000 lux	
Noise Level	< 60 dBA	
Standard Accessories	Hour Counter, 2 pcs. Main Power Socket (2,5 A)	
Power Supply	230 V, 50 Hz.	
Power Consumption	1860 W	
Internal Dimensions (WxDxH) mm.	885x600x650	1190x600x650
External Dimensions (WxDxH) mm.	1060x795x1400	1360x795x1400
Packing Dimensions (WxDxH) mm.	1150x850x1540	1450x850x1540
Net / Packed Weight, kg.	190 / 218	220 / 257

*MN 120 is certified by TUV Nord according to EN 12469: 2008 Standart

ACCESSORIES

S 17 004	Support stand for MN 090
S 17 003	Support stand for MN 120
M 08 024	Gas valve with solenoid valve
M 08 020	Vacuum valve
K 04 361	Front enclosure with U.V. Light for MN 090
K 04 362	Front enclosure with U.V. Light for MN 120

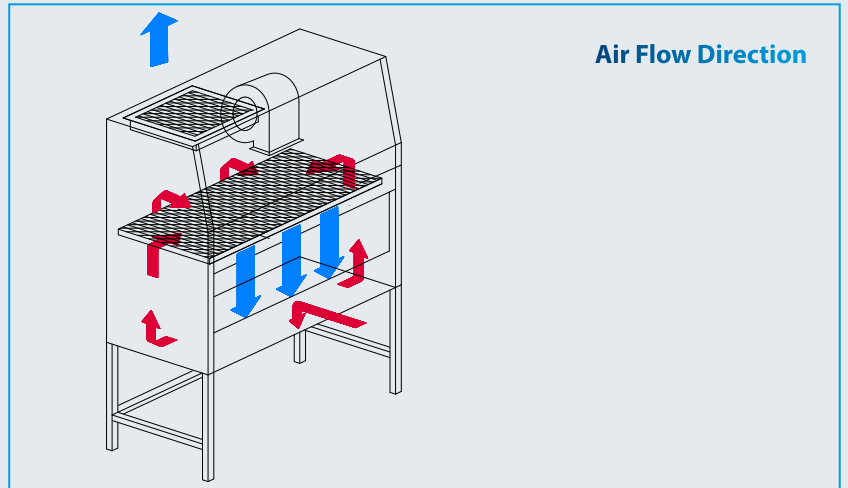

NUVE SANAYİ MALZEMELERİ İMALAT VE TİCARET A.Ş.

Saracalar Mah. Saracalar Kümeevleri No: 4/2 Akyurt 06750 ANKARA / TURKEY t. +90 312 399 28 30 f. +90 312 399 21 97
nuve.com.tr sales@nuve.com.tr

ISO 9001: 2015
ISO 13485: 2016

