

# GATE VALVE PN16 (F4) series 115



VALVES



## APPLICATION

Flanged gate valve for drinking water and neutral liquids up to 80°C

## DESIGN FEATURES

Non rising stainless steel stem	100% watertight
Full bore	No zones of retention
Low closing torque	Replaceable wedge nut
Clockwise closing	Dust protection flanges for sizes DN40-DN250
Maintenance free	Edge protection gasket to avoid damages during transport, storage and assembly for sizes DN40-DN300
Guided wedge to ensure correct sealing	

## TECHNICAL CHARACTERISTICS

Design in accordance to EN1074 and EN1171  
 Face to face dimensions according to EN 558-1 series 14 and DIN3202 (F4)  
 Flange end connections according to EN1092-2: PN10&PN16  
 Maximum working pressure: PN16 / 16 bar  
 Working temperature: 0°C - +80°C  
 Fully vulcanized wedge in EPDM according to EN681  
 Stainless steel bolts  
 Color RAL5015  
 Powder epoxy coating at least 250 µm thickness

## OPERATING



DN	Flange drilling	L	H	H1	D	D1	D2	b	n-Ød	SQ	KG	BLUCAST ref. no.
40	PN10/16	140	220	295	150	110	84	16	4-Ø19	14	8.9	115040
50	PN10/16	150	230	312,5	165	125	99	16	4-Ø19	14	10	115050
60/65	PN10/16	170	265	357,5	185	145	118	16	4-Ø19	17	12	115065
80	PN10/16	180	290	390	200	160	132	16	8-Ø19	17	12.6	115080
80	PN10/16	180	290	390	200	160	132	16	4-Ø19	17	12.6	115H080
100	PN10/16	190	335	445	220	180	156	16	8-Ø19	19	19.5	115100
125	PN10/16	200	380	505	250	210	184	16	8-Ø19	19	26.5	115125
150	PN10/16	210	415	557,5	285	240	211	16	8-Ø23	19	29.9	115150
200	PN10	230	510	680	340	295	266	17	8-Ø23	24	55	115200
200	PN16	230	510	680	340	295	266	17	12-Ø23	24	55	115P200
250	PN10	250	600	800	400	350	319	19	12-Ø23	27	81.5	115250
250	PN16	250	600	800	400	355	319	19	12-Ø28	27	81.5	115P250
300	PN10	270	690	917,5	455	400	370	20,5	12-Ø23	27	111	115300
300	PN16	270	690	917,5	455	410	370	20,5	12-Ø28	27	111	115P300
350	PN10	290	790	1042,5	505	460	429	22,5	16-Ø23	27	171.5	115350
350	PN10/16	290	790	1050	520	470	429	22,5	16-Ø28	27	171.5	115U350
400	PN10	310	855	1137,5	565	515	480	24	16-Ø28	27	211	115400
400	PN10/16	310	855	1145	580	525	480	24	16-Ø31	27	211	115U400
450	PN10/16	330	1006	1326	640	585	548	30	20-Ø31	32	302	115U450
500	PN10	350	1072	1407	670	620	582	31,5	20-Ø28	32	327	115500
500	PN10/16	350	1072	1429,5	715	650	609	31,5	20-Ø34	32	327	115U500
600	PN10	390	1228	1618	780	725	682	36	20-Ø31	32	503	115600
600	PN10/16	390	1228	1648	840	770	720	36	20-Ø37	32	503	115U600

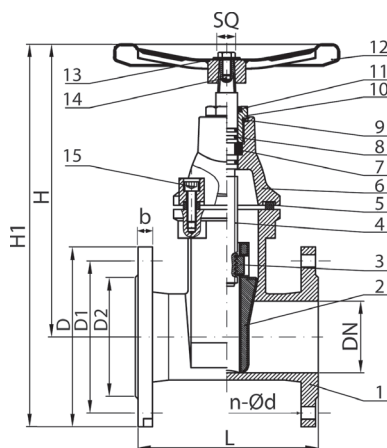

No.	Item	Material
1	Body	EN-GJS-500-7
2	Wedge	EN-GJS-500-7, EPDM
3	Stem nut	Brass
4	Stem	AISI420
5	Sealing gasket	EPDM
6	Bonnet	EN-GJS-500-7
7	Locating ring	Brass
8	Sealing ring	EPDM
9	Sealing ring	EPDM
10	Sealing nut	Brass
11	Sealing ring	EPDM
12	Handwheel	EN-GJS-500-7
13	Washer	AISI304
14	Bolt	AISI304
15	Bolt	AISI304

All illustrations, technical data, dimensions (in mm) and weights (all weights specified in kg) are non-binding and are subject to change

