

SPECIFICATIONS
for
Diagnostic Ultrasound System

ARIETTA 65

MODEL: ARIETTA 65

Scanning Method

- Electronic Convex
- Electronic Linear
- Electronic Phased Array Sector
- Electronic Radial

Operating Modes

- **B-mode**
- BiPlane-mode
- **M-mode**
- D: Spectral Doppler mode (**PW**, **CW***¹, **HPRF-PW**)
- Dual Gate Doppler mode
- **Color Flow mode**
- **Power Doppler mode (Directional Power Doppler)**
- eFLOW mode (Directional eFLOW)
- Detective Flow Imaging(DFI) mode*² (Directional DFI)
- Real-time **3D(4D)** mode*³

*¹ Option: EU-9198

*² Option: SOP-ARIETTA65-105

*³ Option: EU-9198 and SOP-ARIETTA65-4

Image Display Modes

- B: gray-scale imaging
- Dual B
- **Quad B**
- M
- **B and M**
- D: Spectral Doppler (PW, HPRF PW, and CW)
- **B and D**
- B(Color Flow)
- B(Power Doppler)
- B(eFLOW)
- B(DFI)*¹
- **Dual B**(Color Flow)
- **Quad B**(Color Flow)
- Dual B(Power Doppler)
- Quad B(Power Doppler)
- Dual B(eFLOW)
- Quad B(eFLOW)
- Dual B(DFI)*¹
- Quad B(DFI)*¹
- M(Color Flow)
- M(Power Doppler)
- M(eFLOW)
- **M(DFI)*¹**
- B(Color Flow) and M(Color Flow)
- B(Power Doppler) and M(Power Doppler)
- B(eFLOW) and M(eFLOW)
- B(DFI)*¹ and M(DFI)*¹

- B(Color Flow) and D
- B(Color Flow) and Dual Gate Doppler
- B(Power Doppler) and D
- B(Power Doppler) and Dual Gate Doppler
- B(eFLOW) and D
- B(eFLOW) and Dual Gate Doppler
- **B(DFI)*¹ and PW**
- B(Color Flow) and D simultaneous real-time display (**Triplex mode**)
- B(Power Doppler) and D simultaneous real-time display (**Triplex mode**)
- B(eFLOW) and D simultaneous real-time display (**Triplex mode**)
- B(DFI)*¹ and D simultaneous real-time display (**Triplex mode**)
- B and B(Color Flow) simultaneous real-time display (Dual CF)
- B and B(Power Doppler) simultaneous real-time display (Dual CF)
- B and B(eFLOW) simultaneous real-time display (Dual CF)
- B and B(DFI)*¹ simultaneous real-time display (Dual CF)
- Dynamic Slow-motion Display*²
(Real-time image/Slow-motion image, side by side display)
- **Panoramic display***³
- **TDI (Tissue Doppler Imaging)**
- Intermittent trigger mode*⁴
- Monitor Mode*⁴(Fundamental/CHI)
- **Real-time Tissue Elastography** *⁵
- Real-time Biplane(Using Biplane probe, display a real time 2 section image. Probe dependent.)
- Request function: In multi-mode display, it is possible to select one mode for full screen display.
- Real-time 3D(4D) mode*⁶

*¹ Option: SOP-ARIETTA65-105

*² Option: SOP-ARIETTA65-57

*³ Option: SOP-ARIETTA65-1

*⁴ Option: SOP-ARIETTA65-44

*⁵ Option: SOP-ARIETTA65-43

*⁶ Option: EU-9198 and SOP-ARIETTA65-4

Beam former

Transmission

- CPWG (Compound Pulse Wave Generator)
- Programmable waveform transmission

Reception

- Multi-processing high-speed **digital beam former**

12-bit A/D converter (4096 gray levels)

A/D Sampling Frequency: 40[MHz]

Parallel processing: Multiple directions

Transmission/Reception method of Harmonics

Reception frequency: 3.2-18.0* MHz

* Maximum reception frequency can be achieved under below conditions.

•Probe: L64, Freq:High, Freq. Info. :Receive

Tissue Adaptive Technology

Sound speed adjustment: 26 steps

Focusing

Transmission: **Multi-stage transmission focus** of up to 4 stages out of **16 stages** (probe dependent)

Reception: **PixelFocus**

System Dynamic Range

272dB

System Processing Channels

574,976 Channels

Frame rate

Max. 661 frames/sec*

* It is a measured value with the setting assuming the maximum value. This value may be exceeded depending on the conditions

B-mode

- Display Gray Scale: **256 levels**
- Scanning area: 1 degree step
- Line Density: 8 steps
- HI Frame Rate (Multi Parallel Processing)
- **Zoom**
 - **HI zoom** (real-time image):
Max. Up to 0.5 cm display image (probe dependent)
 - **PAN zoom** (real time and frozen image):
Max. Up to 0.5 cm display image (probe dependent)
- Frequency selection:
Fundamental: Max. 4 frequencies (probe dependent)
Tissue harmonic: Max. 4 frequencies (probe dependent)
- Depth range selections:
0.75/1.0/1.5/2.0/2.5/3.0/3.5/4.0/4.5/5.0, 1 cm intervals from 5.0 to 24 cm, and 2cm intervals from 24cm to **40cm** (probe dependent)
- Longitudinal and lateral inversion *
- Rotation by 90 degrees * (probe dependent)
- **Gain** *: 80 dB range

- Echo enhancement: 8steps
 - Smooth/Enhance: 8 steps for each other
 - Persistence: 8steps, including Off (Available to change type for adaptive frame rate)
 - TGC (time gain compensation):
Gain versus depth curve control: 8 slide controls TGC curve memory function
 - LGC (lateral gain control):
Gain versus angle curve control: 8 sectors (Sector probes only)
 - Dynamic range *: 40-90 dB
 - Gray map *: 10 types
 - AGC: 8 steps
 - View gamma *: 4types
 - **Spatial Compound Imaging**
(by selected linear and convex sector probes)
 - **Trapezoidal scan** (possible by selected linear probes)
Available to combine with compound scan
 - **B steer function: This function enables you to use oblique function not only Color Flow/ Power Doppler mode but B mode.**
 - Adaptive Imaging: HI REZ function 8 steps, 2 types
Adaptive imaging is the technique to generate optimum image with changing filter characteristic depending on input signal.
This technique which installed this ultrasound diagnostic scanner reduces speckle noise on B-mode images and provides uniformly and high contrast images.
 - Acoustic Noise Reduction: 8 steps
This technique is reduced acoustic noise (Based on signal level)
 - **Near-field Noise Reduction**
reduces artifacts and noises in the heart chamber or blood vessel
 - Low Echo Reduction *
This technique is compressed low gradient echo level.
 - Grayscale Enhancement *
This technique is enhanced image which is displayed as grayscale.
 - **Auto-optimizer** (Optimization of gain)
 - Needle Emphasis (probe dependent)
 - Wide Scanning (probe dependent)
- * Available after freezing

M-mode:

- Sweep method: Moving bar
- Sweep speed *:
300.0, 200.0, 133.3, 100.0, 66.7, 50.0, 40.0 mm/sec
- Gain *: B-gain ±30 dB

- Dynamic Range *: 40 dB-90 dB
- AGC: 8 steps
- Acoustic Noise Reduction
- Low Echo Reduction *
- Grayscale Enhancement *
- FAM (Free Angular M-mode) *¹

* Available after freezing

*¹ Option: SOP-ARIETTA65-5

Spectral Doppler:

- Display: Power spectrum
- Real-time Doppler Auto Trace
- Doppler methods:
 - PW (Pulsed Wave) Doppler
 - HPRF(High Pulse Repetition Frequency) PW Doppler
 - Dual Gate Doppler
 - CW (Continuous Wave) Doppler *¹
 - **TD (Tissue Doppler) PW**
- Reference frequencies (probe dependent):
 - Maximum 3 frequencies
 - PW: 1.9, 2.0, 2.1, 2.5, 3.0, 3.2, 3.3, 3.5, 3.8, 4.0, 4.3, 5.0, 6.0, 7.5, 8.6 MHz
 - CW: 1.8, 2.0, 2.1, 3.0, 3.3, 3.8, 5.0 MHz
- Pulse Repetition Frequency
 - PW: 0.05 to 40 kHz
- Analysis rate:
 - CW: 1.1 to 40 kHz
- Max. velocity range:
 - PW/HPRF: -8.02 to 0 or 0 to +8.02 m/s
 - CW: -16.0 to 0 or 0 to +16.0 m/s
- Base line shift *
- Steerable CW Doppler: probe dependent
- Steered linear scanning: Max. ± 30 degrees changeable at 5 degrees interval
- Spectrum inversion *
- **Angle correction** *: Available up to 80 degrees (Pre-settable, changeable after freezing) Auto angle correction, Warning function available
- Sample volume size for PW Doppler:
 - 0.5 – 20 mm, changeable in 0.5mm, 1.0 mm step
- Wall motion filter: 12steps, 1/16 of PRF is Max.
- Doppler **gain** *: 60dB **variable** *
- Echo Enhancement(CW): 3 steps
- Low Echo Reduction(PW) *
- Grayscale Enhancement *
- Auto-Optimizer (Optimization of gain, velocity range, baseline shift, sample gate position and angle Correction)

- Audio output: 2 channels

* Available after freezing

*¹ Option:EU-9198

Color Doppler Mode

- Color area size: Continuously variable
- Steered linear scanning:
 - Max. ± 30 degrees *, changeable at 5 degrees interval
 - * Probe dependent
- Line density: Up to 8 steps (Changeable setting independently with B mode)
- Auto-Optimizer (Optimization of gain)

Color Flow Mode

- Display patterns:
 - Velocity (derived from mean Doppler frequency shift), Velocity + variance, Variance, Velocity + intensity, Velocity + variance + intensity
- Max. velocity range: ± 0.63 cm/sec to ± 458.33 cm/sec
- Reference frequency: (Probe dependent)
 - 1.9, 2.0, 2.1, 2.5, 3.0, 3.2, 3.3, 3.5, 3.8, 4.0, 4.3, 5.0, 6.0, 7.5, 8.6 MHz
- Pulse repetition frequency:
 - 0.03 to 19.8 kHz
- Gradation:
 - ± 127 levels for velocity (red and blue)
 - 64 levels for variance (green)
- Color Inversion *: Normal, Invert
- Smoothing: 5 steps
- Wall filter: 6 steps
- Persistence (Color): 8 steps
- Wall Motion Reduction: Off + 3 steps, 2 types
- Packet Size: 3 levels
- Base line shift(Color) *:
 - Up to double velocity (± 127 steps)
- Color coding *: 15 kinds
- TGC Enhancement: 2 kinds
- Power Doppler Mode
 - Display patterns:
 - Power Doppler, Directional Power Doppler
 - Gradation: 256 levels
 - Color coding *: 15 kinds
 - Non-display of B/W image: Possible in ROI
 - Smoothing: 5 levels
- High Resolution Power Doppler(eFLOW) Mode
 - One of the Color Flow imaging functions that can display blood flow information in a high spatial and

temporal resolution.

- Display patterns: eFLOW, Directional eFLOW
- Pulse repetition frequency: 0.03 to 19.8 kHz
- Gradation: 256 levels (± 127 levels for directional)
- Color coding *: 15 kinds
- Non-display of B/W image: Possible in ROI
- Smoothing: 5 levels
- Detective Flow Imaging(DFI) Mode *¹
 - Display patterns: DFI, Directional DFI
 - Gradation: 256 levels
 - Color coding *: 15 kinds
 - Non-display of B/W image: Possible in ROI
 - Smoothing: 5 levels

* Available after freezing

*¹ Option:SOP-ARIETTA65-105 (Probe dependent)

TDI(Tissue Doppler Imaging)

- Function Available

Manual

It is applicable to browse instruction manual on this system.

- On-board operation manual

Cine Memory

- Cine search and loop display (in B mode):
ECG time phase display is possible
- Capacity

B mode: Max. 63,500 frames.

M and D modes: Max. Approx. 900 seconds.

Data Management

1. Image data

1-1. Format

Multiple-frame (moving) image

DICOM (Raw, MJPEG)

PC Format (AVI, WMV, MP4)

Single-frame (still) image

DICOM (Non-compressed, RLE, RGB (Plane/Pixel), JPEG)

PC Format (TIFF, BMP, JPEG)

1-2. Image acquisition mode

- Real-time multi-frame image acquisition (Raw, Image)
 - Acquiring both RAW and Image at the same time
 - Post ECG: Max. 10 cardiac cycles (R-R)
 - Pre ECG: Max. 10 cardiac cycles (R-R)
 - Post Time: Max. 90 seconds
 - Pre Time: Max. 16 seconds

Manual:

Raw data: Max. 150 seconds

Image data: Max. 180 seconds

- Cine loop high-speed data transfer (Raw, Image)
 - It is possible to selectively store data of arbitrary section in the Cine Memory.
- Simultaneous output to multiple media
 - It is possible to output still image data to multiple of storage media include network and printers at the touch of a button.

1-3 Image data management tool

Image viewer

- Thumbnail display of stored images (1-36 images)
- Check mark is put on a transferred image
- Image zoom, rotation, inversion
- 1:1 replay (main unit HDD or DICOM storage data)
 - DVD-RAM
 - DVD-R
 - CD-R
 - USB memory
 - USB HDD
 - Re-storing to media, transfer
 - Adjustment is possible on the reconstructed Raw-data image (gain, dynamic range, gamma curve type, and color coding in Color flow mapping mode)

2. Measurement data

It is possible to store measurement data in the main unit hard disk

3. Patient data

Patient information

ID (up to 64 characters), Name (up to 64 characters, including middle name), Birthday, Sex, Age, Height, Weight, Occupation

Study information

Procedure ID, Accession, Study ID, Study Description
Referring physician, Reporting Phys, Sonographer

Conforms to DICOM 3.0 standard

4. Data storage

- Main unit hard disk
 - Capacity: Approx. 500GB
 - (It is available to change to 1TB HDD)
- USB memory*
- USB HDD*
- CD-R*
- DVD-RAM*
- DVD-R*
- Network interface(DICOM format): 1000baseT, 100baseTX or 10baseT (automatically switched)

- Network folder(BMP, JPEG, TIFF, AVI, MWV, MP4)

* Media is not included in the standard components of this system

5. DICOM network communication*¹

- Conformity to DICOM service class:
 - Ultrasound image storage SCU
 - Ultrasound multi-image storage SCU
 - Comprehensive SR SCU
 - Storage media FSC/FSU/FSR
 - Print management SCU
 - Modality worklist management SCU
 - Modality performed procedure step (MPPS) SCU
 - Storage Commitment Push Model SCU
 - Query/Retrieve SCU
 (For details, please refer to the DICOM Conformance Statement issued by FUJIFILM Healthcare Corporation)

- Storage: Possible to store patient information directly to DICOM file server

- Print: Possible to printout images with DICOM compatible printer directly

- Work list management: Retrieval of patient and reservation information from hospital information system (HIS)

NOTE: The HIS needs to be compatible with DICOM standard supplement 10. The HIS network and the DICOM network need to be linked.

- Router setting: possible

- Compatible with SR (Structured Report) for OB-GYN, cardiology, vascular and abdominal measurements*²

- Query/Retrieve*³

- Profile

- IHE (Integrated Healthcare Enterprise)

- SWF (Scheduled Workflow)

- PDI (Portable Data for Imaging)

- ED (Evidence Documents in Radiology/Cardiology domain)

- Echocardiography Workflow

- CT (Consistent Time)

*¹ Option: SOP-ARIETTA65-10

*² Option: SOP-ARIETTA65-21

*³ Option: SOP-ARIETTA65-59

6. Security measures

User authentication function is available.

3 Types of user authority can be set.

It is possible to set whether password is required or not at the start of operation.

Audit logs

Accesses related to user management and patient

data are recorded as audit log data.

Handling of these logs is limited to users with Level 1 access.

7. Teaching file can be made.

Measurements and Analysis:

Basic measurements

B mode

Distance, Dist-trace, Area/Circum, Volume, Hip J Angle, Histogram, Angle, B.Index

M mode

M.Length, Time, Heart Rate, M.VEL, M.Index

D mode

D.VEL, ACCEL, RI, Time, P1/2T, Heart Rate, D.Caliper, D.Index (Caliper), D.Index (Trace), Mean.VEL., PI, D.Trace, Steno Flow, Regurg Flow, Real-time Doppler auto trace

B/D mode

Blood Flow

B(Flow) mode

Flow Profile*

* Option: SOP-ARIETTA65-7

Application measurements

Obstetrical measurements

- Supports multiple gestations
- Growth analysis function (display of past measurement data)

B mode

Gestational age, Fetal weight

Auto GA*¹ is possible.

Ratio

Amniotic Fluid Index(AFI), AF Pocket/AFV, MVP

CTAR/CTR

Cervical length

Auto NT*²

M mode

Fetal Heart Rate

LV Function

D mode

Blood flow

*¹ Option: SOP-ARIETTA65-76

*² Option: SOP-ARIETTA65-42

Gynecological measurements

B mode

Uterus measurements

Endometrial thickness measurements

Cervical measurements

Ovary measurements

Follicular measurements (Volume measurements by 3-axis measurements are possible.)

Urinary bladder measurements

D mode

Uterine artery

Ovarian artery

Urological measurements

B mode

PSA Volume

PRS slice volume

Bladder

D mode

Renal artery

Cardiology measurement

B mode

LV Volume measurements

M.Simpson*, Area-length*, Pombo**, Teichholz**, Gibson**· Bullet, BP-ellipse, Simpson

*Automatic heart cavity trace is possible. (3-point or full automated method*¹)

** Auto measurement method*¹ is possible.

Valve area measurements (AVA, MVA)

LA/AO

Ratio

Right ventricle measurements

LV myocardial mass

LA/RA Volume measurements

Automatic heart cavity trace*¹ is possible. (3-point or full automated method)

FAC measurements

Automatic heart cavity trace*¹ is possible. (3-point)

IVC (inferior vena cava) measurements

M mode

Pombo (wall), Teichholz (wall), Gibson (wall)

Caliper Mark Auto Shift is possible.

Mitral valve measurements

LA/AO measurements

Auto measurement method*¹ is possible.

Tricuspid valve measurements

Pulmonary valve measurements

IVC (inferior vena cava) measurements

TAPSE measurements

D mode

LVOT (left ventricle outflow tract) flow

RVOT (right ventricle outflow tract) flow

Trans-mitral flow

(Full Automated or Automated setting period method)

Regurgitant flow (AR, PR, MR, TR)

Volumetric flow(MR)

Stenotic flow (AS, PS, MS, TS)

PISA

Pulmonary vein flow
TDI PW
(Full Automated or Automated setting period method)

Coronary flow

Asynchrony

TDI-CF/M mode

Shortening

Percent Systolic Wall Thickening

*1 Option: SOP-ARIETTA65-74 and PEU-ARIETTA65

Vascular measurement

Carotid artery

Blood flow measurement :

CCA (common carotid artery)

ICA (internal carotid artery)

ECA (external carotid artery)

BIFUR (Bifurcation of carotid artery)

VERT (Vertebral artery)

Stenotic rate:

% Stenosis area

% Stenosis diameter

IMT (Intima-media thickness) Measurements:

Automated IMT measurements*¹

IMT-C10 measurements*¹

Measurements of arteries in extremities

Lower extremity artery flow

Upper extremity artery flow

Transit time of Vessel Flow(TVF)*²

Stenotic rate:

% Stenosis area

% Stenosis diameter

Measurements of veins in extremities

Lower extremity venous flow

Upper extremity venous flow

Trans-cranial Doppler

Trans-cranial blood flow measurements

*¹ Option: SOP-ARIETTA 65-38

*² Option: SOP-ARIETTA 65-47 and PEU-ARIETTA65

Abdominal measurement

B mode

Gallbladder measurements

Common bile duct measurements

Liver measurements

Pancreas measurements

Pancreatic duct measurements

Renal measurement

Spleen measurements

Space-occupying lesion measurements

Blood vessel diameter measurements

Stenosis percentage measurements

D mode

Artery measurements

Renal artery measurements

Portal vein measurements

Shunt blood vessel measurement

B/D mode

Flow quantity(Artery)

Flow quantity(Vein)

Small parts measurement

B mode

Lesion measurement

Aspect ratio measurements

Nipple-tumor distance measurement

Thyroid gland volume measurement

Thyroid isthmus thickness measurement

D mode

Artery measurements

Report Functions

Measurement reports

Obstetrical report

Gynecological report

Cardiac function report

Vascular report

IMT (Intima-Media Thickness) report

Urological report

Abdominal measurement report

Small parts report

It is possible to recall past measurement reports.

Examination data history can be plotted on the report.

Direct printout of each report is possible with an optional PC printer.

Output of measurement values in CSV file is possible.

Others

Hot Key function:

It is possible to assign measuring functions to the alphabet keys on the keyboard. (It is needed keyboard)

Measurements on VCR playback image:

Possible (manual calibration)

User's calculation:

30 equations can be set for each application

User-assignable terms: 60 words possible

Font size of measurement result:

Possible to change in 3 kinds

Physiological Signal Display

- Displayed information: ECG, PCG*¹, Pulse wave*², breathing waveform
- ECG synchronized display: Available for one phase
- Detect regular pulse from arrhythmia(RRp/RRpp)
- Display position: Continuously variable (both in B and M modes)
- Bar graph display for breathing waveform
- 3 type electrocardiograms (I, II, III)
- Automated detection end diastole and end systole phase.
- Automated split as end diastole(left) and end systole(right)

*¹ Option: MA-300 (Not available in EU)

*² Option: TY-307A (Not available in EU)

Dual Gate Doppler (Probe dependent)

This is a function which displays Doppler Spectrums of two different sample points simultaneously.

Supported combinations are PW/PW, TDI/TDI, and PW/TDI.

This function is beneficial for functional evaluations of heart failures and phase analysis. For example, E/e' measurements can be performed in a single scan.

Automated sample gate setting for each gate is possible.

Optional Functions

PC printer

It is possible to printout OB/GYN, cardiology, PV, small parts and urology report screens including ultrasound images directly with an external PC printer.

Real-time Tissue Elastography*¹

This function is used to visualize the stiffness of a tissue in real-time. The strain generated in a tissue on applying pressure is represented by colors

(it is available to change Elastography Color Map)

- Elasto mode: Overlapping display of Elastography on B-mode image
- Dual Elasto mode: Dual image display of Elasto mode, possible to select different color map on each side.
- Real-time Biplane: Elasto mode Overlapping display of Elastography on B-mode image of either cross-section, in the function to display B-mode image with the one of different cross-section simultaneously.
- Strain Ratio measurement:
Calculation of ratio of strain between arbitrary 2 regions
- Assist Strain Ratio: Clicking center of the tumor automatically sets the measurement ROI to the tumor and the fatty layer (the mammary gland region and lesion are targeted).
- Strain Graph:
The time variation of distorted average value is displayed on a graph in real time.
- Auto Select Frame:
The frame under stable pressure is chosen automatically.
- Strain Histogram Measurement*²:
Displays a histogram which shows the values of relative strain within an ROI, and calculates the quantitative characteristics of the elasticity image and LF index(Liver Fibrosis Index).
- HI Strain:
Performs the strain calculations based on multiple frames, and displays the most stable elasticity image.
- Compatible to RAW data

*¹ Option: SOP-ARIETTA65-43 (Probe dependent)

*² Option: SOP-ARIETTA65-60

Detective Flow Imaging(DFI)*

Removes motion artifacts from the feature amount of movement obtained by analyzing the received signals in the ROI, and displays images in colors that vary according to the signal intensity. Blood flow is displayed at a high frame rate and is little affected by body movement.

* Option: SOP-ARIETTA65-105 (Probe dependent)

Shear Wave Measurement*¹

hear Wave Measurement is a function for measuring shear wave propagation velocity(Vs), interquartile range of the Vs group(IQR), Vs effective rate(VsN) and the stiffness(E). The propagation velocity of shear waves varies with tissue hardness.

- Shear Wave Measurement mode:
Measures the propagation velocity of shear waves in the target region.
- ROI setting function:
A trackball can be used to change the position of the ROI you select to measure.
- Automatic recording of still images:
The instrument can be set up to automatically send results after measurements.
- Integration with measurement functions:
Measurement data is saved for each selected measurement. You can modify a measurement during an examination.
- Data saved to CSV files:
Measurement data is saved in a CSV file.
- Attenuation measurement(iATT):
Simultaneously with the measurement of Vs, the ultrasound attenuation (ATT) is measured near the center of the ROI.

*¹ Option: SOP-ARIETTA65-73 (Probe dependent)

Automated NT Measurement*

It is possible to automatically extract the nuchal translucency(NT) thickness by simply setting ROI(region of interest). In addition, thicknesses at max NT, Mean NT can be automatically calculated.

* Option: [SOP-ARIETTA65-42](#)

Auto GA*

Automatic fetus measurement function that measurement caliper are appeared automatically after selecting measurement items

Measurement items compatible with Auto GA

- Head: BPD, BPD_o, OFD, OFD_o, HC, HC2, HC3
- Abdomen: APTD, APD, TTD, TAD, AC, AC2, FTA
- Femur: FL

* Option: SOP-ARIETTA65-76

2D Tissue Tracking (2DTT) *

2DTT enables the evaluations of regional wall motion abnormalities within your region of interest, such as the

myocardium and valves automatically by speckle tracking method on a B-mode image. With only minimal angle dependency, analysis from various cross sections have become possible. Multiple analyses, including wall thickness, various strains and rotation angle can be performed.

Analysis

- Free use
 - Distance and angular change between 2 points of your choice can be analyzed.
- SAX: Parasternal short-axis view
 - Circumferential Strain and Strain Rate
 - Radial Strain and Strain Rate Global Circumferential Strain, Strain Rate
 - Angle and Angle Rate
 - Twist (With Overlay function)
- APEX: Apical long-axis view
 - Apex-S (Strain)
 - Longitudinal Strain and Strain Rate
 - Transverse Strain and Strain Rate
 - Global Longitudinal Strain and Strain Rate
 - Volume
 - Apex-V (Volume)
 - Volume for cavity
 - Single and Biplane EF(With Overlay Function)
 - dv/dt(volume variation velocity)
 - Center of gravity coordinate, display tracking

View

- SAX
 - Basal SAX
 - Mid SAX
 - Apical SAX
- APEX-S, -V
 - 2ch, 3ch, 4ch (Inversion view included)

Graph Type

- Line Graph
- Color Graph
- Line & Color Graph
- Bull's eye (with Overlay function)

Measurements

- Point to Point
- Time to Peak
- 3 point: One-third point of diastole duration
- Distance

*Option :SOP-ARIETTA65-49 and PEU-ARIETTA65

Stress echo analysis*

Image display modes in which image acquisition is possible: B, Each Flow modes

- Image acquisition methods:
 - ECG synchronized acquisition
- Compatible frame rate: Up to 75 Hz
- Recalled screen
 - Playback speed: Selectable
 - Image allocation: Possible
 - Scoring: Possible
 - Automatic registration: On/Off
- Protocol: Skip view function is available.
 - Exercise stress protocols:
 - Exercise Stress Echo
 - Treadmill Exercise
 - Bicycle Exercise
 - Pharmacological stress protocols:
 - DSE
 - High-Dose DSE
 - Low-Dose DSE
 - Arbutamine
 - Dipyridamole
 - User's protocol:
 - The user can make a protocol within **8 views X 12 stages in 1 exam.**
 - Full disclosure (Multi acquisition): 270 seconds
- Scoring screen
 - Playback speed: Selectable
 - Comparison between different stages in the same view is possible
 - Image playback range is selectable
 - Systolic image acquisition
 - Bull's eye display (16 or 17 segmentation selectable)
- Report screen
 - Display format
 - Chart/Stage overview/View overview

*Option: SOP-ARIETTA65-15 and PEU-ARIETTA65

TDI analysis*

Tissue Doppler Imaging (TDI) analysis is an echocardiographic technique employing the Doppler principle to measure the velocity of myocardial segments and other cardiac structures.

Strain information analysis is also available.

B-mode

- Temporal Velocity Profile
 - Velocity, time, acceleration, ratio
- Regional Velocity Profile
 - Velocity, distance
- TDI-Myocardial Thickness (Wall thickness)
 - Distance, time, velocity

Strain rate

Time, strain rate

Strain

Time, strain

M-mode

Velocity trace

Velocity, time, acceleration, ratio, velocity difference

TDI-Myocardial Thickness (wall thickness)

Distance, time, velocity

Velocity Profile

Velocity, distance

CSV output of analyzed data is possible. CSV is a file format that can be converted into Excel file directly.

*Option: SOP-ARIETTA65-13 and PEU-ARIETTA65

CHI (Contrast Harmonic Imaging)*

Contrast agent generates abundant second harmonics when disrupted, which eases detection by Harmonic Echo. Setting for low-pressure type contrast agent is also incorporated.

- Wide-band Contrast Harmonic Imaging (WbC)
The wideband pulse inversion method enables retrieval of echoes from the ultrasound contrast agent across a broad spectrum and display them in CHI mode at a high level of sensitivity.
 - Tissue Reduction Contrast Harmonic Imaging (TrC)
The Amplitude Modulation method makes it possible to reduce signals from tissue to get clearer CHI mode images.
 - Monitor mode
In the Monitor mode, images are available with a low sound pressure during the intermission of high sound pressure transmission.
 - Motion-compensated Accumulation Imaging
It is possible to display running of fine blood vessels by accumulating contrast echo information.
 - Flash
This mode sends high acoustic pressure transmissions at set intervals to destroy the ultrasound contrast agent.
 - Frame Rate Limit
Function of limiting Frame Rate not to break bubbles.
- * Option: SOP-ARIETTA65-44 (Probe dependent)

Automated IMT Measurement*

It is possible to automatically extract max IMT, min IMT, mean IMT and SD by simply setting ROI (region of interest) on a long-axis view of the vessel. In addition, the

thicknesses at 3 points, i.e., the point at max IMT, and the points at 1cm on the right and left of the max IMT, can be automatically detected and averaged.

* Option: SOP-ARIETTA65-38

Panoramic display*

It is possible to display an image of an extensive range of the body by moving the probe. An area wider than the scanning width of the probe can be displayed.

* Option: SOP-ARIETTA65-1

Protocol Assistant*

This function provides the capability to guide study by displaying protocol list (view name, mode, measure).

It is useful to improve everyday study.

- Available to registered protocol: 128 kinds
- Suspend protocol function
- Available to edit protocol on the system
- Available to register and edit reference image
- Available to import or export like preset

* Option: SOP-ARIETTA65-79

Real-time 3D (4D)*

- It is possible to display 3 arbitrary sections simultaneously
- **MPR (Multi-planar Reconstruction)**
- 360 degrees omni-directional rotation
- 4 kinds of rendering selectable
- Combination of 2 kinds of rendering type (Rendering Mode Mix)
- Detail scan of the ROI (Region of interest) is possible
- Inversion Mode (black-and-white)
- B-mode measurements on an arbitrary plane possible
- Auto Clipper : Automated placenta rejection function
- Multi Slice Imaging (MSI)
- HI REZ
- Lower Threshold
- 4Dshading
- Snapshot : 3D image (1 View) is magnified and printed in color

* Option: EU-9198 and SOP-ARIETTA65-4 (Probe dependent)

BiopSee Connection software*

This function links with the MedCom software, BiopSee software, to perform prostate biopsy.

Use an external PC connected to the system to start the BiopSee software, and then link the software with the system via a LAN connection and a DVI connection.

- Available to display the BiopSee software started on the

external PC

•Available to display an ultrasonic image on the BiopSee software in real time

* Option: MP-FX-ALB-38, MP-FX-ALB-6B, EU-6060B and SOP-ARIETTA65-159 (Probe dependent)

In addition, preparation of BiopSee software, an external PC, mouse, keyboard, stepper, foot switch, etc. is required for BiopSee.

Supported only in countries with the regulatory approval for MedCom's BiopSee software.

General Specifications

Acoustic Power

- 0 to 100%, 5% step

Preset Function

- 100 kinds (Max. 25 kinds per each probe)
- Preset contents storable in USB memory
- Q.S.S.(Quick Scanning Selector):
Image modifying parameters (e.g. Gain, frequency, depth) of your choice can be registered. (Up to 4 sets per preset)
These parameters can immediately be registered and selected by touch panel during examinations.
- Preset is booted up in conjunction with ID information(BodyParts or etc,)

Characters and graphic displays

Character input area:

- ID*, name, age, sex, retained text
* Can be corrected after exam
- **Input is possible with virtual keyboard on LCD panel**
- Automatic Annotation Labeling:
800 words (User registration is possible. 10 Class)
- Body mark:
38 kinds are available per each region.
6 regions+1 user are able to register.
Probe mark: 4 kinds
Display position: changeable
Fetal body mark: rotatable
- Assist line display (Probe dependent)

Menu control

- **10.1-inch color TFT LCD touch panel**

Active Probe Ports

- **For electronic scanning probes: 4**
- For independent probes*: 1

*Option: EU-9187B, EU-9198

Input/Output Signals

- Data Input/Output
USB2.0 : 5 channel(Main unit 3+ Operation Panel 2)
- Digital Video Input/Output
Output
DVI-D digital
Resolution: WXGA++(1600x900)
Digital video with **HDMI** connector*
Resolution: Full HD(1920x1080), XGA(1024x768),
VGA(640x480)
*Option: EU-9210
Input

DVI-D digital

Resolution: WXGA++(1600x900)

- Analog Video Input/Output
Output
Y/C: 1 channels
Input
Y/C: 1 channel
- Network
LAN (Wired, Wireless)
- Others
Audio (L/R): 2 channel (Output 1, Input 1)

Storage

- **SSD**
- **HDD**

Viewing Monitor

- **21.5 inch LCD display**
Resolution: **Full HD (1920 x 1080)**
- Tilt and swivel are possible.
- **Height adjustment and swivel together with operation panel**

Safety Regulation

- IEC 60601-1: 2012
Class I, Type BF

Environmental Requirements

In Operation

- Temperature: +10 to +40 degrees C
- Relative Humidity: 30 to 75%
(non condensing)
- Atmospheric pressure: 700 to 1060 hPa
- Altitude: Up to 3000m

In Storage/transportation

- Temperature: -10 to +50 degrees C
- Relative Humidity: 10 to 90%
(non condensing)
- Atmospheric pressure: 700 to 1060 hPa

Power Requirement

- 100 to 120/ 200 to 240V ±10%, 50 or 60 Hz,
Max. 750 VA (with options connected)
- Battery drive time *
70 minutes (first time use, 25 degrees C environment,
B mode scanning)
Battery driving time (battery capacity) may reduce
depending on the charge-discharge repetition and
environment.
*Option:EU-9199

Dimensions

- 53.3 cm (W) × 74.2 cm (D) ×126.5 – 163.5 cm (H)

Weight

- 85 kg (main unit only)

System Configuration

Unite			Remarks
Category	Name	Model name	
System	Diagnostic ultrasound system	ARIETTA 65	includes a viewing monitor
Peripheral Interface / Connection Kit / Mounting Rack	Digital color printer (SONY)	UP-D25MD	EU-6060B, PM-AR65-H002, MP-FX-ALB-30 and MP-FX-ALB-31 are necessary. MP-FX-ALB-34 is necessary when mounting HD video recorder together.
	Digital color printer (MITSUBISHI)	CP30DW	EU-6060B, PM-AR65-H002, MP-FX-ALB-30 and MP-FX-ALB-32 are necessary. MP-FX-ALB-35 is necessary when mounting HD video recorder together.
	Hybrid graphic printer (SONY)	UP-X898MD	PM-AR65-H001 is necessary
	Digital BW printer (MITSUBISHI)	P95DW	PM-AR65-H001 is necessary
	Digital BW printer (MITSUBISHI)	P95DE	PM-AR65-H001 is necessary
	HD video recorder	HVO-500MD/FHD	EU-6060B, PM-AR65-H003, MP-FX-ALB-30 and MP-FX-ALB-33 are necessary. MP-FX-ALB-34 is necessary when mounting UP-D25MD together. MP-FX-ALB-35 is necessary when mounting CP30DW together. PM-AR65-H003 is available for the model with SN:114857~.
	HD video recorder	HVO-550MD/FHD	EU-6060B, PM-AR65-H003, MP-FX-ALB-30 and MP-FX-ALB-33 are necessary. MP-FX-ALB-34 is necessary when mounting UP-D25MD together. MP-FX-ALB-35 is necessary when mounting CP30DW together. PM-AR65-H003 is available for the model with SN:11071~.
	CD-R/DVD Disk Drive unit		
	Outlet expansion unit	EU-6060B	Unavailable during the operation on battery power.
	connection kit	PM-AR65-H001	
	connection kit	PM-AR65-H002	
	connection kit	PM-AR65-H003	
Hardware Option	Physiological signal display unit	PEU-ARIETTA65	
	Independent probe connection unit	EU-9187B	EU-9198 is necessary.
	CW & 3D unit	EU-9198	
	Battery unit	EU-9199	
	Shear Wave Measurement unit	EU-9206	
	Jelly warmer	JW-3000U	EU-6063 and MP-FX-AVA-2B-R or MP-FX-AVA-2B-L are necessary. Unavailable during the operation on battery power.
	AC adopter for Jelly warmer	EU-6063	JW-3000U and MP-FX-AVA-2B-R or MP-FX-AVA-2B-L are necessary.
	3-point foot switch	MP-2819	
	1-point foot switch	MP-2345B	
	Small tray	MP-FX-ALB-21	
	Side tray	MP-FX-ALB-22	
	Peripheral mounting bracket	MP-FX-ALB-30	This is required when mounting color printer, medical video recorder, and when mounting monochrome printer in combination with aforementioned devices.
	Mounting rack of Color printer(SONY)	MP-FX-ALB-31	
	Mounting rack of Color printer(MITSUBISHI)	MP-FX-ALB-32	
	Mounting rack of Digital video	MP-FX-ALB-33	
	Peripheral expansion rack	MP-FX-ALB-34	This is required when mounting UP-D25MD and HD video recorder together on the system.
Peripheral expansion rack	MP-FX-ALB-35	This is required when mounting CP30DW and HD video recorder together on the system.	
BiopSee Mounting kit *	MP-FX-ALB-38	It is impossible to simultaneously mount this and Digital color printer or HD video recorder.	

			SOP-ARIETTA65-159, MP-FX-ALB-6B, and EU-6060B are necessary.
	Flexible hook	MP-HA-ALB-2	It is impossible to simultaneously mount this and MP-HA-ALB-3.
	Flexible hanger	MP-HA-ALB-3	It is impossible to simultaneously mount this and MP-HA-ALB-2.
	Keyboard tray	MP-FX-ALB-6B	Optional keyboard is necessary.
	Jelly warmer right side mounting kit	MP-FX-AVA-2B-R	JW-3000U and EU-6063 are necessary.
	Jelly warmer left side mounting kit	MP-FX-AVA-2B-L	JW-3000U and EU-6063 are necessary.
	Small probe holder (RS)	MP-PH-AR70-2U	
	Small probe holder (LS)	MP-PH-AR70-4U	
	Large probe holder (LS)	MP-PH-AR70-5U	It is possible to attach at the back left if MP-FX-AVA-2B-L is not installed.
	Large probe holder (RS)	MP-PH-AR70-6U	It is possible to attach at the back right if MP-FX-AVA-2B-R is not installed.
	Adapter for large probe holder (for thin and long probes)	MP-PHAD-AR70-1U	
	Adapter for large probe holder	MP-PH-ADAPTER-5BU	
	Endo-cavity probe holder kit	MP-PH-AVA-11B	
	HDD expansion unit	AR65 Built-in 1T HDD	Factory built-in option
	HDMI-monitor connection unit	EU-9210	
Software Option	Panoramic View software	SOP-ARIETTA65-1	
	Real-time 3D software	SOP-ARIETTA65-4	EU-9198 is necessary.
	FAM software	SOP-ARIETTA65-5	
	Flow Profile Measurement software	SOP-ARIETTA65-7	
	DICOM network communication software	SOP-ARIETTA65-10	
	TDI Analysis software	SOP-ARIETTA65-13	
	Stress Echo software	SOP-ARIETTA65-15	PEU-ARIETTA65 is necessary.
	DICOM Structured Report software	SOP-ARIETTA65-21	SOP-ARIETTA65-10 is necessary.
	Automated IMT Measurement software	SOP-ARIETTA65-38	
	Automated NT Measurement software	SOP-ARIETTA65-42	
	Real-time Tissue Elastography software	SOP-ARIETTA65-43	Most of attachment / adapter is optional. See "Optional Probes" description.
	Contrast Harmonic Imaging software	SOP-ARIETTA65-44	
	Transit Time of Vessel Flow measurement software	SOP-ARIETTA65-47	PEU-ARIETTA65 is necessary.
	2D Tissue Tracking Analysis software	SOP-ARIETTA65-49	
	Dynamic Slow-motion Display software	SOP-ARIETTA65-57	PEU-ARIETTA65 is necessary for DSD(ECG)
	DICOM Query/Retrieve software	SOP-ARIETTA65-59	SOP-ARIETTA65-10 is necessary.
	Real-time Tissue Elastography Strain Histogram software	SOP-ARIETTA65-60	SOP-ARIETTA65-43 is necessary.
	Shear Wave Measurement Software	SOP-ARIETTA65-73	EU-9206 is necessary
	Automated Cardiac Measurement software	SOP-ARIETTA65-74	PEU-ARIETTA65 is necessary for auto measurement in M mode..
	Automated OB Measurement software	SOP-ARIETTA65-76	
Protocol Assistant software	SOP-ARIETTA65-79		
Detective Flow Imaging software	SOP-ARIETTA65-105		
McAfee Embedded control 3 software	SOP-ARIETTA65-128		
BiopSee Connection software *	SOP-ARIETTA65-159	MP-FX-ALB-38, MP-FX-ALB-6B, and EU-6060B are necessary.	

* Supported only in countries with the regulatory approval for MedCom's BiopSee software.

Optional Probes

Electronic convex sector probes

Application (description)	Model	Frequency range (MHz)	Scanning angle (degrees)	Optional accessories
Abdominal	C251	5.0~1.0	70	CIVCO Bracket(for puncture) 644-082*1, *5/644-083*1, *5
Abdominal	C253	5.0~1.0	70	CIVCO Bracket(for puncture) 644-082*1, *5/644-083*1, *5
Abdominal	C253A	5.0~1.0	70	CIVCO Bracket(for puncture) 644-082*1, *5/644-083*1, *5
Abdominal	C35	8.0~2.0	70	CIVCO Bracket(for puncture) 644-082*1, *5/644-083*1, *5
Abdominal	C41	13.0~4.0	100	-
Abdominal	C42	8.0~4.0	80	Needle Guide Bracket EZU-PA532*1 CIVCO Bracket(for puncture) 644-077*1, *5/644-078*1, *5
Abdominal	C421	12.0~3.0	100*	CIVCO Bracket(for puncture) 644-098*1, *5/644-099*1, *5 Waterproof case WP-001*6
Intraoperative	C22K	6.0~1.0	82	Puncture Adapter MP-2781 MP-2781-5 MP-2781-25 CIVCO Bracket(for puncture) 614-108*1, *5/614-109*1, *5
Abdominal	C22P	6.0~1.0	74	Needle Guide Bracket EZU-PA7C2*1 Puncture Adapter MP-2824
Abdominal	C23	6.0~1.0	110*	CIVCO Bracket(for puncture) 644-096*1, *5/644-095*1, *5 644-094*1 Waterproof case WP-001*6
Abdominal	C23RV	6.0~1.0	110*	CIVCO Bracket(for puncture) 644-096*1, *5/644-095*1, *5 644-094*1 Waterproof case WP-001*6
Abdominal	C25P*2	5.0~1.0	70	Biopsy Attachment EZU-PA7B1-1 EZU-PA7B1-2 EZU-PA7B1-3 EZU-PA7B1-4 EZU-PA7B1-C
Intraoperative	C42K	10.0~4.0	65	Puncture Adapter MP-2783 MP-2458 CIVCO Bracket(for puncture) 614-068*1, *5/614-100*1, *5
Intraoperative	C42T	10.0~3.0	65	Waterproof case WP-001*6
Transvaginal Transrectal	C41B	10.0~2.0	200	Puncture Guide Tube MP-2445 Rubber Boot RB-945BP-NS Waterproof case WP-001*6
Transvaginal Transrectal	C41V	8.0~4.0	200	Sterile Puncture Adapter EZU-PA5V
Transvaginal Transrectal	C41V1	10.0~2.0	200	Sterile Puncture Adapter EZU-PA7V

Transrectal	C41RP	9.0~2.0	180	Puncture Guide Tube MP-2452 Rubber Boot RB-665P-NS Waterproof case WP-001* ⁶
-------------	-------	---------	-----	--

* When Wide Scanning is On.

Electronic linear probes

Application (description)	Model	Frequency range (MHz)	Scanning width (mm)	Optional accessories
Peripheral Vessel	L441	12.0~2.0	38	CIVCO Bracket(for puncture) 644-075* ^{1, *5} /644-076* ^{1, *5}
Peripheral Vessel	L442	12.0~2.0	38	Coupler Attachment(for puncture) EZU-PA7L1
Small Organ	L34	7.0~3.0	38	Coupler Attachment(for puncture) EZU-PA3C1H CIVCO Bracket(for puncture) 644-079* ^{1, *5} /644-080* ^{1, *5}
Small Organ	L55	13.0~5.0	50	Needle Guide Bracket EZU-PA7L2* ¹
Small Organ	L64	18.0~5.0	38	Needle Guide Bracket EZU-PA7L3* ¹ Acoustic Coupler SF-001 EZU-TECPL1 Acoustic Coupler Attachment EZU-TEATC2
Intraoperative	L43K	12.0~2.0	26	Waterproof case WP-001* ⁶
Intraoperative	L44K	14.0~2.0	42	Waterproof case WP-001* ⁶
Intraoperative	L44LA	13.0~2.0	36	-
Intraoperative	L46K1	14.0~2.0	63	Waterproof case WP-001* ⁶
Intraoperative	L51K	15.0~3.0	13	Waterproof case WP-001* ⁶
Intraoperative	L53K	15.0~3.0	25	Waterproof case WP-001* ⁶
Intraoperative	L31KP	9.0~2.0	6	Puncture Adapter MP-2450 (standard) Waterproof case WP-001* ⁶

Electronic phased array sector probes

Application (description)	Model	Frequency range (MHz)	Scanning angle (degrees)	Optional accessories
Cardiac Adult	S11	5.0~1.0	90	-
Cardiac Adult	S211	5.0~1.0	90	-
Cardiac Pediatric	S31	9.0~2.0	90	-
Cardiac Pediatric	S42	14.0~3.0	90	
Cardiac, TEE	S3ESEL* ³	8.0~2.0	90	-
Cardiac, TEE	S3ESL1	9.0~2.0	90	
Intraoperative	S31KP* ⁴	8.0~3.0	90	Puncture Adapter MP-2450 (standard) Waterproof case WP-001* ⁶

Real-time 3D(4D) probes*

* **EU-9198** and **SOP-ARIETTA65-4** are necessary

Application (description)	Model	Frequency range (MHz)	Scanning angle (degrees)	Optional accessories
Fetal	VC35	8.0~2.0	72	-
Transvaginal	VC41V	8.0~2.0	145	-

Electronic radial probes

Application (description)	Model	Frequency range (MHz)	Scanning angle (degrees)	Optional accessories
Transrectal	R41R	10.0~5.0	360	Waterproof case WP-001* ⁶

Biplane probe

Application (description)	Model	Frequency range (MHz)	Scanning angle(degrees) / width(mm)	Optional accessories
Transrectal	CC41R	8.0~4.0	100/120	Sterile Puncture Adapter EZU-PA5V Puncture Guide Fixture EZU-PA3U Waterproof case WP-001* ⁶
Transrectal	CC41R1	10.0~2.0	180/180	Sterile Puncture Adapter EZU-PA5V Rubber Boot RB-945BP-NS Waterproof case WP-001* ⁶
Transrectal	CC41R2	10.0~2.0	200*/200*	Gap adapter OP-001 (Standard) CIVCO Needle Guides 644-101* ⁵ /644-102* ⁵ Rubber Boot RB-945BP-NS CIV-Flex Endocavity Probe Covers 610-006* ⁵ PROcovers 610-075* ⁵ /610-076* ⁵ Waterproof case WP-001* ⁶
Transrectal	CL4416R Convex	10.0~2.0	180	Puncture Guide Fixture

	Linear	14.0~2.0	63	BA-001 Rubber Boot RB-945BP-NS Waterproof case WP-001* ⁶
Transrectal	CL4416R1 Convex Linear	10.0~2.0	200*	Puncture Guide Fixture BA-001 Rubber Boot RB-945BP-NS Waterproof case WP-001* ⁶
		14.0~2.0	63	
Transrectal	C41L47RP Convex Linear	8.0~4.0	200	Puncture Guide Fixture EZU-PA3U
		10.0~5.0	64	

* When Wide Scanning is On.

Independent CW Doppler probes*

* Independent probe connection unit **EU-9198** and **EU-9187B** are necessary

Application (description)	Model	Frequency range (MHz)	Optional accessories
Cardiac Adult	UST-2265-2	2.0	-

*¹ Needle Guide Kit is necessary.

*² One of puncture adapter is necessary.

*³ Probe cover (CIVCO transducer cover 610-933*⁵) is necessary to use S3ESEL

*⁴ One piece of MP-2450 is attached.

*⁵ CIVCO products are manufactured and sold by CIVCO Medical. It does not suggest that CIVCO products describe in this specification are commercially available in all countries and regions.

*⁶ Not available in USA

Probes and available functions

Basic functions

	Compound	Trapezoid	B steer	Wide Scanning	Acoustic Noise Reduction	Near-field Noise Reduction	Real-time Biplane	Dual Display Format	OMNI Mode	TDI mode	Puncture Guide Line	Needle Emphasis	Brachy Grid Display	Assist Line	Tissue Harmonic Imaging			Dual Gate Doppler
															FmT	WbT	HdT	
C251	✓				✓	✓				✓	✓				✓	✓	✓	✓
C253	✓				✓	✓				✓	✓				✓	✓	✓	✓
C243A	✓				✓	✓				✓	✓				✓	✓	✓	✓
C35	✓				✓	✓				✓	✓				✓	✓	✓	✓
C41	✓				✓	✓											✓	✓
C42	✓				✓	✓					✓						✓	✓
C421	✓			✓	✓	✓					✓						✓	✓
C22P	✓				✓	✓					✓						✓	✓
C23	✓			✓	✓	✓					✓						✓	✓
C23RV	✓			✓	✓	✓					✓						✓	✓
C25P	✓				✓	✓					✓				✓	✓	✓	✓
C41V	✓				✓	✓					✓						✓	✓
C41V1	✓				✓	✓					✓						✓	✓
C41RP	✓				✓	✓					✓						✓	✓
C41B	✓				✓	✓					✓						✓	✓
CC41R	✓					✓	✓	✓			✓							✓
CC41R1	✓					✓	✓	✓			✓							✓
CC41R2	✓			✓		✓	✓	✓			✓							✓
C22K	✓				✓	✓					✓						✓	✓
C42K	✓				✓	✓					✓						✓	✓
C42T	✓				✓	✓											✓	✓
R41R						✓												✓
L34	✓	✓	✓		✓	✓					✓	✓					✓	✓
L441	✓	✓	✓		✓	✓					✓	✓					✓	✓
L442	✓	✓	✓		✓	✓					✓	✓		✓			✓	✓
L55	✓	✓	✓		✓	✓			✓		✓	✓					✓	✓
L64	✓	✓	✓		✓	✓					✓	✓		✓			✓	✓
L43K	✓	✓	✓		✓	✓											✓	✓
L44K	✓	✓	✓		✓	✓											✓	✓
L46K1	✓	✓	✓		✓	✓											✓	✓
L51K	✓	✓	✓		✓	✓											✓	✓
L53K	✓	✓	✓		✓	✓											✓	✓
L31KP	✓	✓			✓	✓					✓							✓
L44LA	✓	✓	✓		✓	✓											✓	✓
S11					✓	✓				✓							✓	✓
S211					✓	✓				✓							✓	✓
S31					✓	✓				✓							✓	✓
S42					✓	✓				✓							✓	✓
S3ESEL					✓	✓				✓								✓
S3ESL1					✓	✓				✓								✓
S31KP					✓	✓					✓							✓
VC35	✓				✓	✓				✓							✓	✓
VC41V	✓				✓	✓		✓									✓	✓
C41L47RP(CV)	✓				✓	✓		✓					✓					✓
C41L47RP(LN)	✓	✓	✓		✓	✓		✓			✓							✓
CL4416R(CV)	✓				✓	✓	✓	✓					✓					✓
CL4416R(LN)	✓	✓	✓		✓	✓	✓	✓			✓							✓
CL4416R1(CV)	✓			✓	✓	✓	✓	✓					✓					✓
CL4416R1(LN)	✓	✓	✓		✓	✓	✓	✓			✓							✓
UST-2265-2																		

Optional functions

	CW mode	DFI mode	FAM	Contrast Harmonic Imaging			Panoramic display	Real-time Tissue Elastography	Real-time 3D	Stress echo	Shear Wave Measurement	BiopSee mode*
				Low	Mid	High						
C251	✓	✓	✓				✓	✓			✓	
C253	✓	✓	✓	✓	✓		✓	✓			✓	
C253A	✓	✓	✓	✓	✓		✓	✓			✓	
C35	✓		✓				✓	✓				
C41			✓									
C42	✓		✓				✓	✓				
C421	✓		✓	✓	✓		✓	✓				
C22P			✓									
C23			✓	✓	✓							
C23RV			✓	✓	✓							
C25P			✓									
C41V			✓					✓				
C41V1			✓					✓				
C41RP			✓									
C41B			✓					✓				
CC41R			✓					✓				
CC41R1			✓					✓				
CC41R2			✓	✓	✓			✓				
C22K			✓									
C42K			✓					✓				
C42T			✓	✓	✓			✓				
R41R								✓				
L34	✓		✓				✓	✓				
L441	✓		✓				✓	✓				
L442	✓	✓	✓				✓	✓				
L55			✓				✓	✓				
L64	✓	✓	✓				✓	✓				
L43K			✓	✓	✓			✓				
L44K			✓	✓	✓			✓				
L46K1			✓					✓				
L51K			✓					✓				
L53K			✓					✓				
L31KP			✓									
L44LA			✓	✓	✓			✓				
S11	✓		✓							✓		
S211	✓		✓							✓		
S31	✓		✓							✓		
S42	✓		✓							✓		
S3ESEL	✓		✓									
S3ESL1	✓		✓									
S31KP			✓									
VC35			✓						✓			
VC41V			✓					✓	✓			
C41L47RP(CV)			✓					✓				✓
C41L47RP(LN)			✓				✓	✓				✓
CL4416R(CV)			✓					✓				
CL4416R(LN)			✓				✓	✓				
CL4416R1(CV)			✓					✓				✓
CL4416R1(LN)			✓				✓	✓				✓
UST-2265-2	✓											

* Supported only in countries with the regulatory approval for MedCom's BiopSee software.

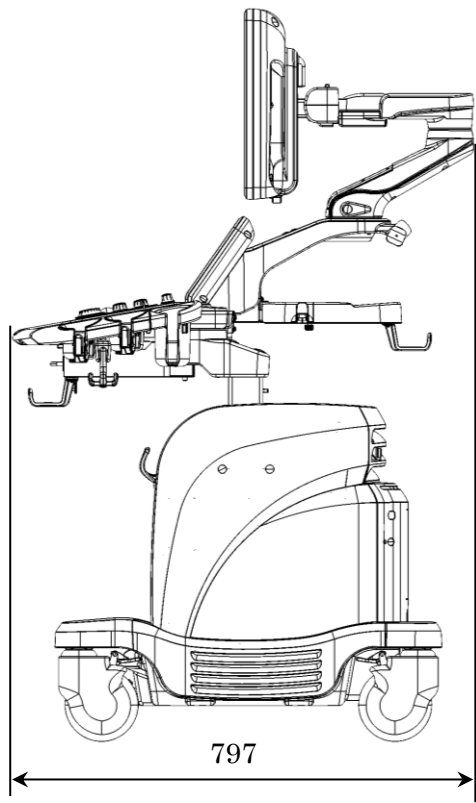
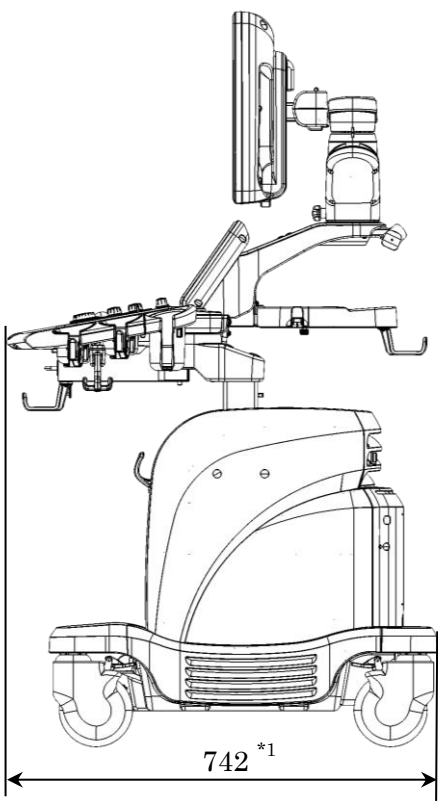
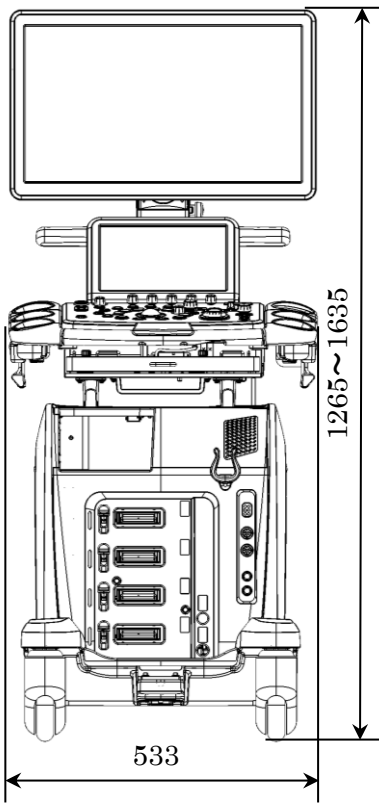
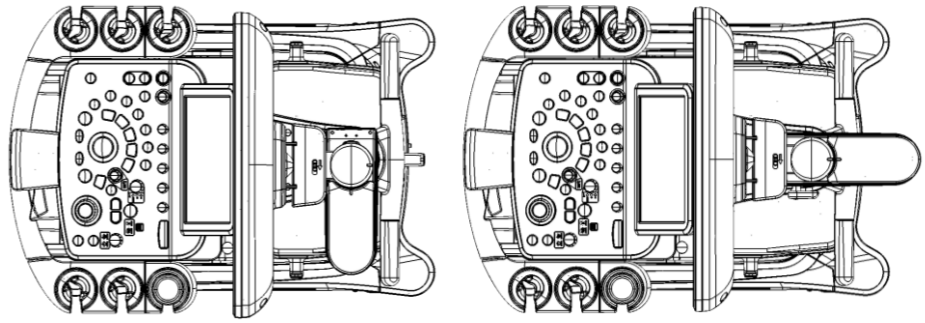

Unit: mm

*1 when the monitor arm is folded

-
- The specifications are subject to change without notice.
 - The standard components and optional items differ depending on the country.
Not all products are marketed in all countries.
Please contact your local FUJIFILM Healthcare Corporation distributors for details.
 - ARIETTA, HI REZ, Real-time Tissue Elastography and 4Dshading are registered trademarks or trademarks of FUJIFILM Healthcare Corporation in Japan and other countries.
 - McAfee is a registered trademark or trademark of McAfee LCC in the United States and other countries.
 - DICOM is a registered trademark of the National Electrical Manufacturers Association in the United States for its standards publications relating to digital communications of medical information.
 - Excel is a registered trademark or trademark of Microsoft Corporation in the United States and other countries.
 - CIVCO is a registered trademark or trademark of CIVCO Medical Instruments Co., Inc. in the United States and other countries.
 - HDMI is a registered trademark or trademark of HDMI Licensing LLC in the United States and other countries.
 - BiopSee is a registered trademark or trademark of MedCom GmbH in the EU and other countries.
 - FUJIFILM and FUJIFILM logo are registered trademarks or trademarks of FUJIFILM Corporation.

FUJIFILM Healthcare Corporation

9-7-3, Akasaka, Minato-ku, Tokyo 107-0052, Japan