

BIOBASE

**Vertical Autoclave
BKQ-Z30/50/75/100I
User Manual**

BIOBASE GROUP

Version 2020.08

Preface

Welcome to choose Flip-open Door Type Vertical Autoclave Sterilizer from Biobase, we hereby express our sincere thanks.

We sincerely hope that our product can bring you great help.

In order to let you know more about Flip-open door type vertical autoclave sterilizer, please read this manual carefully before using. This Manual is very helpful for you to operate safely and correctly.

After reading the manual, please put it in an appropriate position for easy access.

Content

Preface.....	1
Equipment identification	4
1. Unpacking, installation, debugging.....	7
1.1 Unpacking	7
1.2 Checking the accessories.....	7
1.3 Required operations environment	8
1.4 Installation.....	8
1.5 Debugging.....	9
2. User Instructions.....	10
2.1 Product structure	10
2.2 Introduction of safety device.....	12
2.3 Specifications	12
3. Operating procedures of Autoclave Sterilizer	14
3.1 Preparation before Sterilization.....	14
3.1.1 Preparation of instruments and containers	14
3.1.2 Preparation of rubber tube.....	14
3.1.3 Preparation of dressing bag	14
3.1.4 Preparation of Medium	14
3.2 Operation of Device	14
3.2.1 Introduction of user interface	14
3.2.2 Operating procedures	15
3.2.3 Fault indication.....	20
4. Corrective Maintenance	22
4.1 Maintenance	22
4.2 Failure analysis.....	22
4.3 Changing the sterilizer water	22
4.4 Checking the safety valve	23
4.5 How to replace the safety valve	23

BIOBASE

4.6 Thermostat.....	23
4.7 How to improve the operating temperature of the thermostat.....	23
5. Service.....	24
Appendix I: Electrical wiring diagram.....	25
Appendix II: PID piping schematics	26

Equipment identification



Paid great attention

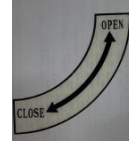

Open door

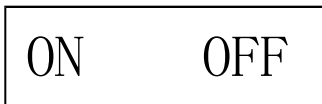

Power



Grounding sign

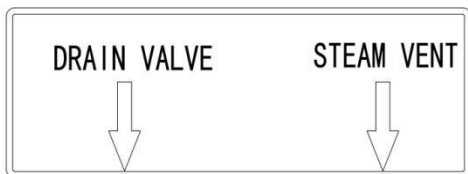

Water draining



High temperature

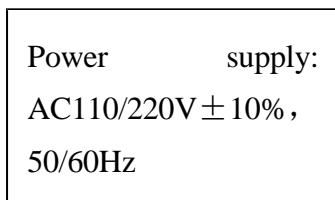

Power ground



Safety valve

BIOBASE

1. Please using the machine according to the manual operation method and notes, if not, may damage the equipment protection system, and cause human unsafe factors and hazard.
2. The user manual should be preserved completely during usage period, and it should be transferred or handed over along with the device when the place changing.
3. Make ensure there is a gap of 25cm to the stuffs around the device for heat dissipation.
4. If equipment was stored under wet conditions, probably did not meet all requirements of this user manual, therefore, it need aeration-drying for a period of time, and then keep it under normal conditions for storages.
5. This equipment is only suitable for the sterilization of high temperature and humidity-resistance medical instruments and stuffs, cannot be used for petroleum jelly, oil, powder, and high-volatility materials such as alcohol, gasoline and stuffs that corrode copper and aluminum.
6. If there is peculiar smell, abnormal noise during use, please cut off the power supply immediately, and contact with local distributor and our after-sales department.
7. The device is not suitable for sealed liquid material sterilization.
8. Unpackaged sterilization should be immediately reserved, transported and applicated under the clean condition, to avoid infection or cross infection again.
9. Only production enterprises, after-sales service department and authorized agent can check and provide the components. In addition, except the provided spare parts, the end-user and individual shall not replace any parts.
10. When the equipment failure, seriously damaged beyond repair, or exceed the lifetime, please deal with the equipment according to the local relevant laws and regulations.
11. Technical parameters:

Model	BKQ-Z30I	BKQ-Z50I	BKQ-Z75I	BKQ-Z100I
Designed pressure	0.28Mpa			
Designed temp.	150°C			
Working pressure	0.23Mpa			
Working Temp. range	105~136°C			
Temp. accuracy	0.1°C			
Pressure range	0~0.4Mpa			
Dynamic pulse exhaust times	0~9times			
Power supply	AC110/220V ± 10%,50/60Hz			
chamber material	S30408			
Required water	distilled/ demineralized water			
Capacity	30L	50L	75L	100L

BIOBASE

Power Consumption (KW)	4	4	4	4
Gross weight (Kg)	100	103	114	122
Chamber size (Φ*L mm)	385*412	385*515	385*715	385*915
External size (W*D*H) mm	610*645*710	610*645*850	610*645*1000	610*645*1200

1. Unpacking, installation, debugging

Please firstly check if packing box is in good condition. If the packing box is damaged, please take photos.

1.1 Unpacking

Using the scissor to cut off the packing belts, take down the carton cover and move off the carton body, refer to picture 1.

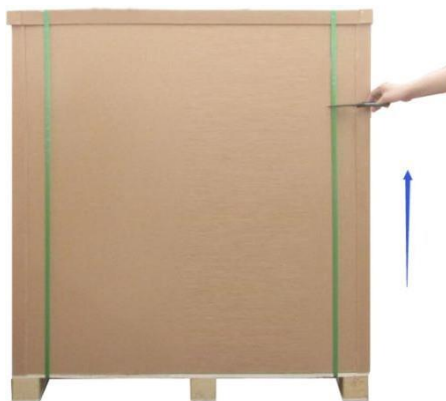

Picture 1 Autoclave package

1.2 Checking the accessories.

Checking whether the accessories is complete according to the packing list.

Packing list

Name	quantity	Position
Autoclave	1pc	Carton
Drain pipe	1 pc	Packing bag (above the cabinet)
Basket	1pc	Inside the machine
User manual	1pc	envelope (above the cabinet)
Test report	1pc	envelope (above the cabinet)
Qualification	1pc	envelope (above the cabinet)

1.3 Required operations environment

The autoclave should be placed in a clean, dry, avoid light, ventilation, lower temperature difference indoor environment.

1. Indoor temp.: 5°C-40°C。
2. Max. relative humidity: 85%。
3. Allowed voltage fluctuating range: ±10%
4. No dust and pollution in the room.

1.4 Installation

1) Remove all packaging components; Place BKQ-Z50I vertical type autoclave sterilizer on the smooth, clean and spacious ground, adjust feet of the machine to be parallel with the ground, to ensure it is stable and reliable. The distance between the back and sides of the machine with other objects must be at least 250 mm (as shown in picture 2, to ensure good ventilation.



Attention: the autoclave will be error due to the accumulation of heat if it is close with the wall.

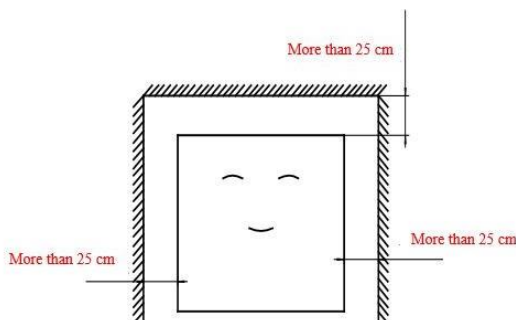

Picture 2

- 2) Checking the surface of the body whether there is a scratch, deformation or foreign matters.
- 3) Checking the accessories and information according to the packing list, take out the spare parts from the packages, and check whether they are complete. Check whether the power supply shown in the nameplate is same as the actual power supply, power on the equipment to test below items;

Test items	Normal condition
Open and close the door	The door is opened and closed smoothly
Display buttons	All the buttons is available

4) water preparation.

Water quality:

Electrical conductivity <15μA/cm

The content of bleach <2mg/L, hardness < 0.02mm/l

PH: 5-7

Water volume: Adding water until the indicator light off.

1.5 Debugging

- 1) Open the door, put in the sterilizer indicator card and biological indicator card, reset and close the door tightly
- 2) Power on, the display will enter into program selection interface after 2 seconds.

2. User Instructions

2.1 Product structure

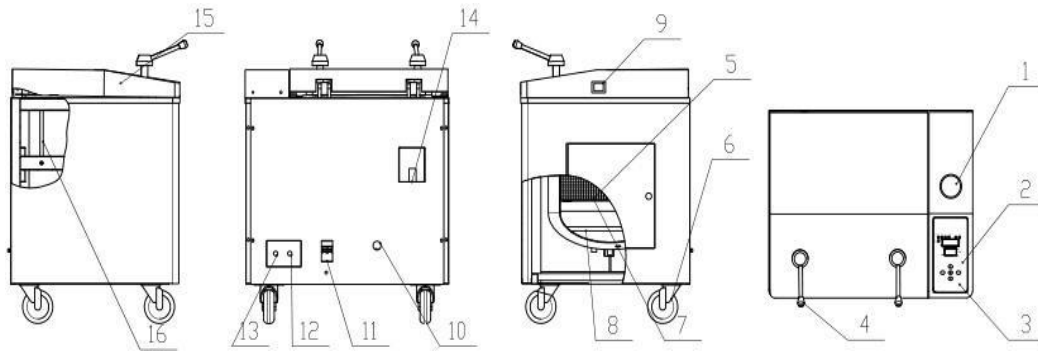

Picture 3

- | | |
|-------------------------|-------------------|
| 1. Pressure gauge | 2. Display screen |
| 3. Control panel | 4. Handle |
| 5. Sterilization basket | 6. Castor |
| 7. Clapboard | 8. Heating pipe |
| 9. Power switch | 10. Power line |
| 11. Air switch | 12. Exhaust port |
| 13. Drain ball valve | 14. Safety valve |
| 15. Door cover | 16. Gas spring |

Main function of spare parts:

NO.	Description	Function
1	pressure gauge	when the device is working, display the pressure within the main body
2	display screen	the entire sterilization process under real-time macro monitoring
3	control panel	mounting the display panel
4	handle	rotating to open the door
5	sterilization basket	loading sterilization items
6	universal castor	support equipment and the equipment can be moved on a smooth surface
7	clapboard	prevent sterilization items from splashed water below
8	heating pipe	heating water for sterilization
9	Power switch	control the equipment power
10	power line	connect device with power supply (yellow is ground wire)
11	air switch	main power switch and leakage protection
12	exhaust outlet	cold air and steam release outlet
13	drain ball valve	drain the waste water from the chamber after sterilization
14	safety valve	relief valve by a predetermined operating pressure to ensure safety
15	door cover	cover of the door, acts as insulation to protect the operator
16	gas spring	for easy opening

2.2 Introduction of safety device

BKQ-Z50I Vertical Sterilizer safety device is provided as follows:

- 1) Automatic over-temperature protection: Over the programmed temperature, the system will automatically cut off the heating power, and display alarm information.
- 2) Alarm: When the temperature of the sterilization chamber is higher than the thermostat set temperature, the thermostat operate, the system will cut off the heating power (and show alarm information).
- 3) Automatic pressure relief safety valve: Over setting pressure, the safety valve opens to release the pressure.
- 4) Circuit safety devices: AC short circuit protection.

2.3 Specifications

Suitable for sterilization of temperature-proof, pressure-proof, humidity-proof medical equipment, medical dressing kits, glassware, rubber, liquid and other items, it can also be used to sterilize laboratory medium.

Seven of the sterilizer sterilization procedures are as follows:

Procedure type	Pulse exhaust times	Pulse start temperature °C	Pulse end temperature °C	Sterilization temp °C	Sterilization time set (min)	Soaking time
1#bare equipment	1	sterilization temperature -2.5	Pulse start temperature -5	134	4	0
2#instrument set	2	sterilization temperature -2.5	Pulse start temperature -5	134	8	0
3#rubber	2	sterilization temperature -2.5	Pulse start temperature -5	121	25	0
4#dressing	3	sterilization temperature -2.5	Pulse start temperature -5	134	12	0
5#liquid type	0	—	—	121	20	0

BIOBASE

6# solid kind of custom	0-9	sterilization temperature -2.5	Pulse start temperature -5	105~136 (134)	(0-999)	0
7# liquid type of custom	0	—		105~136 (134)	(0-999)	0
Blow off valve close set	the local atmospheric pressure -2°C (default 98°C); set range (80-110°C)				Description: a. fixed procedure can be set except for fixed parameters; drainage process during limited time 4 minutes and 100 °C were first starting time for the drying. b. liquid procedure to drain when cool to 105-110 ° C, when cooled to 80 ° C, suggesting sterilization is complete, open the door	
Drainage selection set	After the completion of sterilization, drainage (Off / On) can be set; drain temperature (default is cooled to 105 °C when drainage), setting range: solid of custom (105 ~ 134 °C); liquid of custom (105-110 °C)					
Note:	Steam exhaust and drainage limit temperature not higher than the upper sterilization temperature.					

The service life of the equipment design for five years



Notes

Sterilizer should strictly follow the steps described in the instruction manual operations. If sterilization is not functioning properly, you may want to consult this manual fault analysis table to see whether you can do the self-exclusion, if not you should immediately provide feedback to our service department. If you can provide a detailed description of sterilization failure and the potential required replacement model and the number of replaced parts, the company would be deeply grateful for your support.

3. Operating procedures of Autoclave Sterilizer

3.1 Preparation before Sterilization

3.1.1 Preparation of instruments and containers.

Please clean the instruments or containers first, in case the residuals on the instruments would harm the Autoclave Sterilize. For example blood and other impurities. We have developed specific cleaning solution for your reference:

- 1) We recommend that you use washing machines, cleaning agents and distilled water to clean instruments before sterilization.
- 2) Then wash it again to make sure it is clean.
- 3) When you put the instruments into basket, please put different type instruments into different baskets. E.g. Stainless steel, carbon steel. And please leave adequate space between instruments. If put carbon steel equipment into basket, please put several layers of paper or paper kapok inside basket to avoid direct contact between carbon steel and stainless steel.
- 4) Test tubes and bottles should be placed with opening vertically downward to facilitate the replacement of cold air and the entrance of saturated steam.
- 5) Place a sterilization indicator card in each basket
- 6) Once a month, put spore creatures detection indicator in the load to detect the sterilization effect
- 7) The basket is not allowed to be overload (max. is 12kg), otherwise sterilization will be inadequate.
- 8) The instruments need to be sterilized should be wrapped with packaging material of good permeability. E.g. Sterilization bags, sterilization paper, muslin etc.

3.1.2 Preparation of rubber tube

Please wash the rubber tube with warm water, and then place it on a clean sterile tray while ensuring that the tube is a hollow pipe with two openings, no sharp turn, twist, kink etc.

3.1.3 Preparation of dressing bag

Put the dressing bags on the tray vertically to avoid connection with the inner wall of autoclave sterilizer.

3.1.4 Preparation of Medium

Only medium basket is allowed to use, the load cannot exceed 2/3 of the volume to avoid the overflow of medium.

3.2 Operation of Device

3.2.1 Introduction of user interface

Five keys include "Temperature", "Time", "▲", "▼", "On/off". Six status indicator lamps: "water", "warm", "sterilization", "exhaust", "complete", "alarm" and the "temperature display window", "time display window"

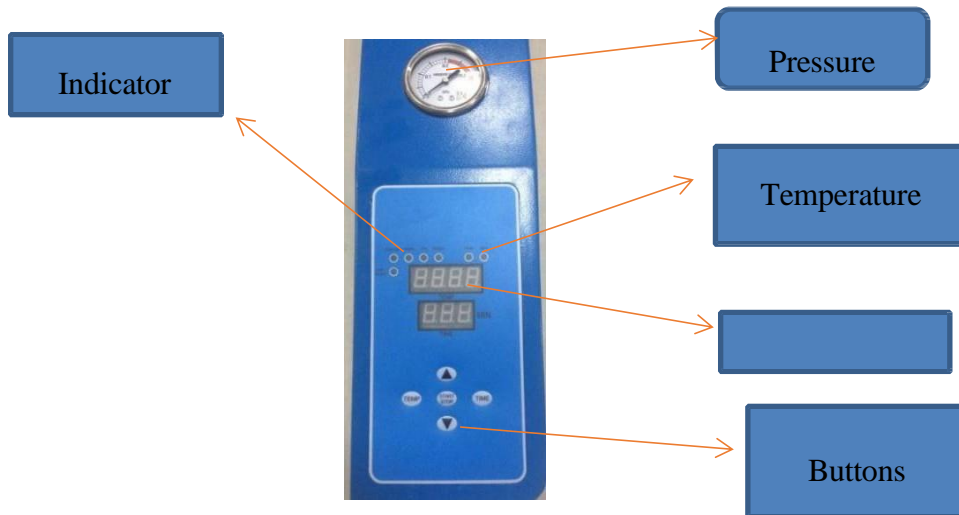

Picture 4

3.2.2 Operating procedures

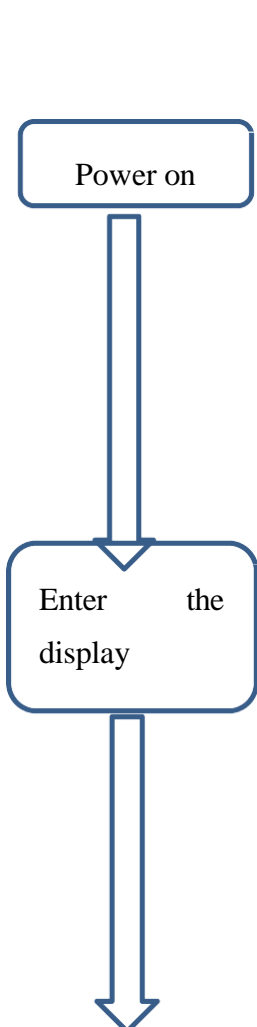

Power on, turned on the air switch behind and then turn on ship type switch on the control panel to enter the display panel.



The temperature display window display Prog, the time window display X(1-7) , indicating you have chosen X# sterilization program. Then the temperature and sterilization time set are displayed. This 2 images display

alternately.

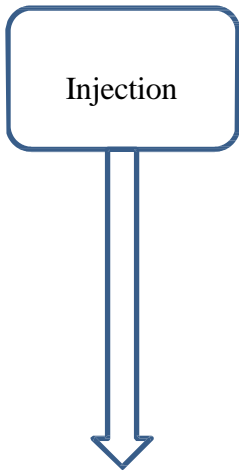

Open the lid to inject water to the pot until the water level Light is off. Then put the item to be sterilized into basket and put basket into autoclave sterilizer. Closed door and choose sterilization procedure.

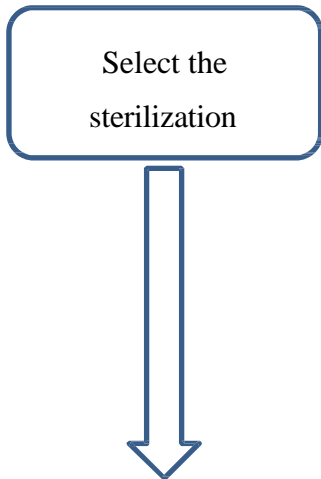

You can select different sterilization procedures with “▲”,“▼”.When you choose 5# liquid program,” Liquid” indicator Light is on. When you choose 7#liquid customized program, the indicator light flashes, indicating the program is for liquid.

Press the ‘Start/Stop’, the according sterilization program start.

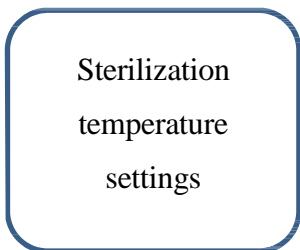



Press the "temperature" button, temperature display window displays temperature values and flashes. Adjust temperature value by “▲”“▼”.
Repress "Temperature" button, the temperature set is stored.

Sterilization
temperature
settings



Press“Time”button, the time display window displays time value and Flash.
Adjust temperature value by “▲”、“▼”.Repress "Temperature" button, the temperature set is stored.

Sterilization



After warming up, sterilization begins. Then exhaust begins.



When the equipment exhaust, put exhaust pipe outside of drains. Don't touch the exhaust pipe in case be burned.

End of sterilization



When sterilization is completed, the "Finish" light buzzer beep every 10 seconds. "Finish" lights on, this sterilization ended.



Be sure that pressure gauge pointer back to 0. Then you can open the lid and get out items.

Preferences:

Press the "Start / Stop" and "temperature" button at the same time for 5 seconds to enter the menu

1) Showing "0480" is water time in minutes, press the "Start / Stop" displayed value and flashes, press "▲"、"▼" turn up or turn down, press "Start / Stop" to confirm. It must be 10 while showing "0480", press "▼" showing "EATE", press "▲" showing "E E F",

2) Showing "EATE" Indicates the end of the cool air discharge temperature, press the "Start / Stop" displayed value and flashes, press "▲"、"▼" to turn up or turn down, press "Start / Stop" to confirm. The default setting is 100.0 °C

Showing "EATE", press "▼" showing "EAE0", press "▲" showing "0480"

3) Showing "EAE0" is exhaust cool air time in minutes, press the "Start / Stop" displayed value and flashes, press "▲"、"▼" to turn up or turn down, press "Start / Stop" to confirm. The default setting is 30 minutes. (After the end of the exhaust cool air, temperature cannot be lower than the set temperature end value, otherwise it will alarm if the pot temperature exceeds 105 degrees will go to the next step directly)

BIOBASE

while showing "E A E E" , press "▼" showing "E Y E E", press "▲" showing "E A E E"

4) Showing "E Y E E" is the time of drainage in seconds, press the "Start / Stop" and the value display flashes, press "▲", "▼" to turn up or turn down, press "Start / Stop" to confirm. Only solid program, the default is 240 seconds.

While showing "E Y E E" , press "▼" showing "P U L S", press "▲" showing "E A E E"

5) Showing "P U L S" is sterilization pulsation frequency in seconds, press the "Start / Stop" displayed value and flashes, press "▲", "▼" to turn up or turn down, press "Start / Stop" to confirm. Only custom procedures for effective solid class, default 0.

While showing "P U L S" , press "▼" showing "d r e e", press "▲" showing "E Y E E"

6) Showing "d r e e" is drying time, in minutes, press the "Start / Stop" displayed value and flashes, press "▲", "▼" to turn up or turn down, press "Start / Stop" to confirm. Only solid custom program, default 10.

While showing "d r e e" , pressing "▼" showing "H o e e", press "▲" showing "P U L S"

7) Showing "H o e e" is incubation temperature in degrees Celsius, press the "Start / Stop" displayed value and flashes, press "▲", "▼" to turn up or turn down, press "Start / End" to confirm.

While showing "H o e e" , pressing "▼" showing "H o e e", press "▲" showing "d r e e"

8) Showing "H o e e" is soaking time in minutes, press the "Start / Stop" displayed value and flashes, press "▲", "▼" to turn up or turn down, press "Start / Stop" to confirm.

While showing "H o e e" , press "▼" showing "E E F A", press "▲" showing "H o e e"

9) Showing "E E F A" is the temperature correction factor, press the "Start / Stop" displayed

BIOBASE

value and flashes, press “▲”、“▼”to turn up or turn down, press "start / stop" to confirm, modify user is strictly prohibited.

While showing“**E E F A**” , press“▼”showing“**E E r F**”, press“▲”showing“**H o E**
E”

10) Showing“**E E r F**”is the temperature deviation, press the "Start / Stop" and the value display flashes, pressing “▲”、“▼”to turn up or turn down, press "start / stop" to confirm, modify user is strictly prohibited.

While showing“**E E r F**” , press“▼”showing“**E E E E**”, press“▲”showing“**E E**”, **F**
ASo the cycle.

After the modification is complete, press the "Start / Stop" and "temperature" button for 5 seconds to save the parameters and exit the menu.



Note:

If you want to terminate the process of sterilization , you can press "Start / Stop" button to end the sterilization process.

3.2.3 Fault indication

error code	cause of issue	Problems	solution
Err 001	After 30 minutes, the pulsating exhaust air conditioner does not reach the set temperature	Heating broken, there are air leaks	Check or replace the heating pipe line leaks
Err 002	Not reached within the time set by the cool air discharge temperature or pulsating exhaust failure	Heating bad parameter setting unreasonable	Replace the heating pipe or check whether the set parameters are correct
Err 004	When the set temperature, the temperature is not stabilized within 10 minutes during the sterilization or excessive temperature fluctuations	There leak	Check the pot connector or line leaks phenomenon.

BIOBASE

Err 008	Sensor is not connected or damaged, the pot temperature below 10 °C	Sensor failure	Replace the sensor
Err 016	PCB temperature component failure	Circuit board burned	Replace the circuit board
Err 032	Within the set time no water add enough water	Bad water level float	Replace the water level float switch
Err 064	Heating pot of water lead to dry	Missing or internal cavity temperature protection failure	Add enough water cooled enough, or replace the temperature protection

4. Corrective Maintenance

4.1 Maintenance

To ensure that the sterilizer in good working condition and minimize the number of failures, therefore, the operation described in this chapter must be followed.

- 1) Before starting maintenance, make sure the device is powered down. At the same time, no pressure in sterilization container.
- 2) After the end of the working with a soft cloth or a piece of gauze to wipe the door gasket.
- 3) Remove the basket. With gauze with a detergent and water, wipe the inner wall of the sterilization container. Do not use steel slag wool or steel brush to avoid damaging the sterilization chamber wall.
- 4) Cleaning and sterilizing the container chamber to remove scale. The water in the tank let go.
- 5) Periodic inspection

Once a year, tightening fittings and detection-off state, should be completed by a professional electrician. Once, due to extreme wear and tear, lock device must be checked every five years.

Instructions: This repair manual is to provide professionals. Unless you are a professional, otherwise when the equipment fails, be sure to consult the instructions and press the manual for repair. Instructions have been possible to provide professional maintenance methods.



Before starting maintenance, make sure the device is powered down. At the same time, no pressure in sterilization container.

4.2 Failure analysis

Phenomena	Possible reasons	Correct Operation
Power switch is on, power light is not bright.	1.The circuit breaker is unclosed 2.The main power switch is damaged	1.Close the circuit breaker 2.Change power switch in accordance of specific conditions
Under the condition of warming, Pressure and temperature do not rise, or rise slowly	1.Control circuit of the heater shorts out or burns down 2.pipe joint or safety valve leaks seriously	1.Check and change the damaged elements 2.check, tighten the pipe joint, safety valve, etc

4.3 Changing the sterilizer water

- 1) Remove the transparent silicone tube can drain until the water drain out.
- 2) Distilled water was injected into the sterilization chamber, the water level should reach the warning indicator light no longer show.

4.4 Checking the safety valve

It is located above the front left side of the device. In order to prevent the safety valve is in the blocked state, under normal use, , Allow the steam pressure release every two months.

- 1) According to the manual, operating sterilizer.
- 2) The pressure generated inside the sterilization container: 0.165MPa.
- 3) Use a screwdriver to push the safety valve handle, opening it about 2 seconds
- 4) Turn off the main switch, the operation is terminated. Meanwhile, exhausting the steam in sterilizer container.
- 5) Turn down the pressure is 0MPa before opening the door.

4.5 How to replace the safety valve

Instructions: The only professional repair methods can be used. Unless you are a professional talent, otherwise avoid electric shock, equipment malfunction, be sure to consult the instructions and press the manual for repair, while the specification has been possible to provide professional maintenance methods.

- 1) It is located above the front left side of the device.
- 2) Remove the valve mounting screws, remove the valve from the valve base.
- 3) With a qualified safety valve to replace it. Test the sterilization process.

4.6 Thermostat

Located inside the device. Sterilizer is equipped with a thermostat. In the heating and sterilization phases, it can be turned with the cut off the power supply to maintain a constant temperature. Typically used as a temperature alarm device. If the pot temperature exceeds the allowable value, the thermostat automatically disconnect the heater power. When the pot temperature dropped below the allowable value, the thermostat automatically turns on.

4.7 How to improve the operating temperature of the thermostat

Thermostat is a liquid expansion thermostat, clockwise to increase the temperature range.
(Note: The device is already regulate before delivered, customers do not need to adjust)

5. Service

Any product has the possibility of failure, please monitor the work of the equipment in real time during use, If any abnormal, please first refer to the manual for processing, If the problem still cannot be solved, you shall inform our Customer Service Center, to protect against loss.

After-sales service

1. From the day when the equipment is sold (subject to the invoice), one-year free maintenance and all-life services.
2. The warranty card: When you need to normal consultation or maintenance, please contact to our after-sales service centers with the warranty card and the invoice, the warranty card must be well kept.

Appendix I: Electrical wiring diagram

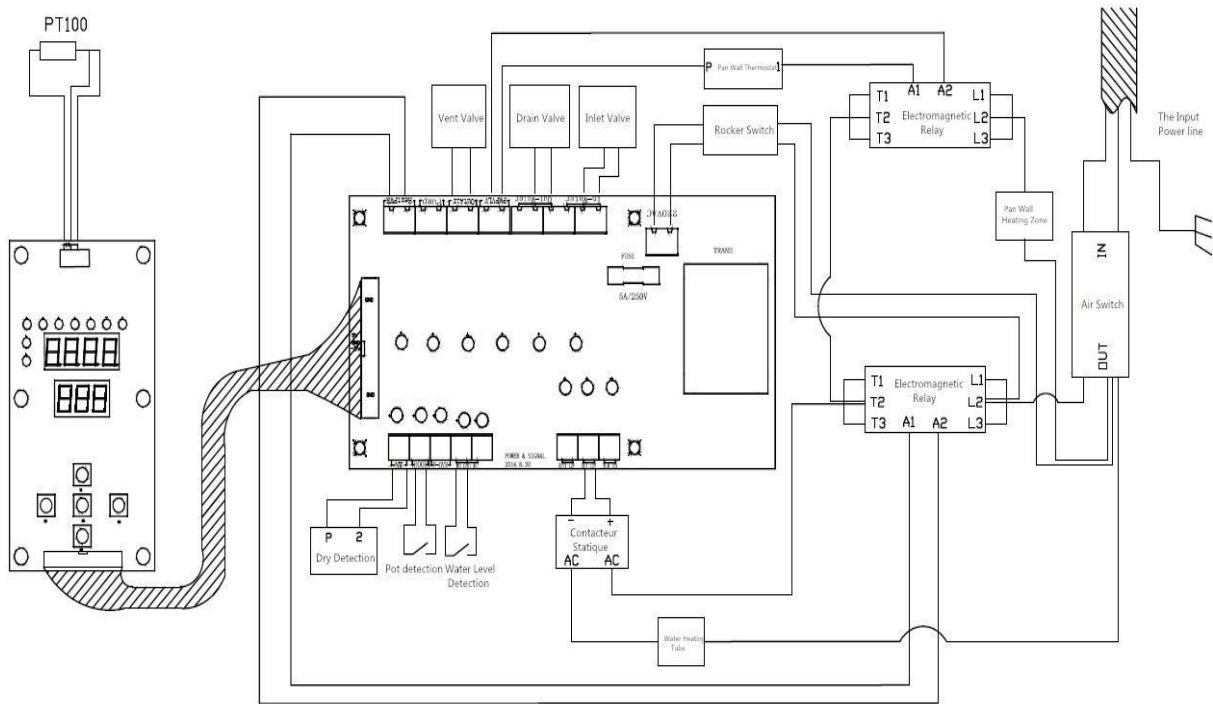

Appendix II: PID piping schematics

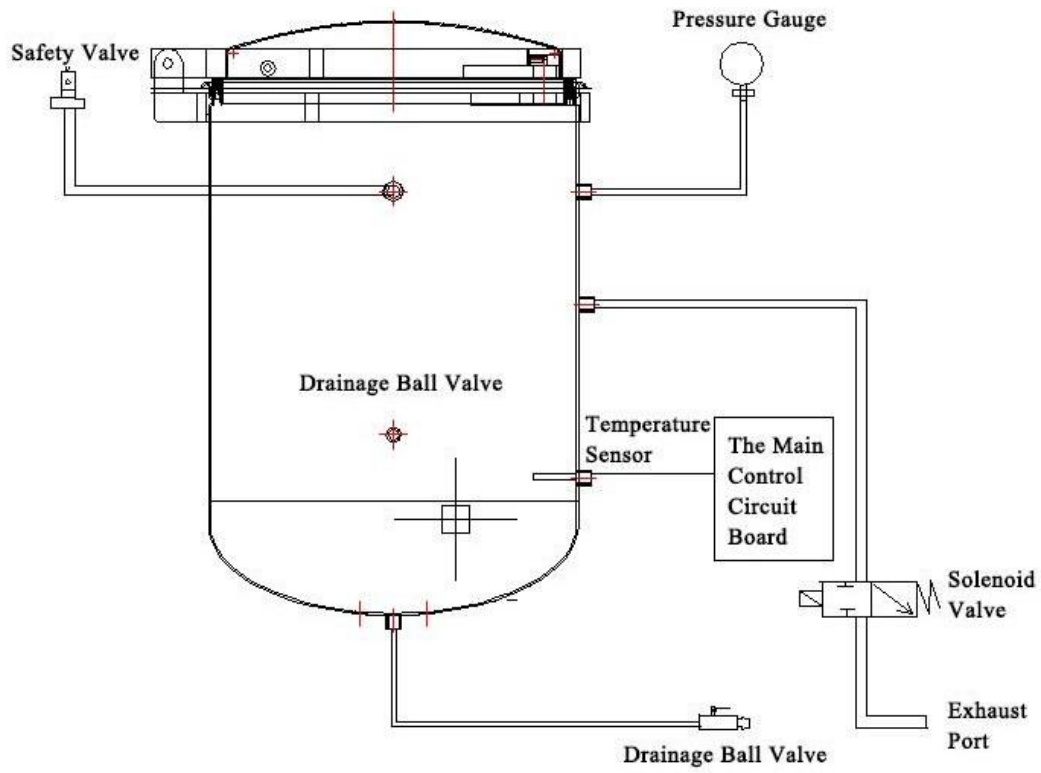

BIOBASE GROUP

2# building, No.9 Gangxing Road, High-tech Zone, Jinan City, Shandong Province,
China

Tel: +86-531-81219803/01

Fax: +86-531-81219804

Inquiry: export@biobase.com

Complaints: customer_support@biobase.cc

After-sales service: service_sd@biobase.cc; service_ivd@biobase.cc

Web: www.biobase.cc/www.meihuatrade.com / www.biobase.com