

**TECHNICAL AND MOTION DOCUMENTATION  
INSTRUCTIONS FOR USE  
WARRANTY CARD  
EXCHANGE PARTS CATALOG  
For wood chippers for PTO drive  
RED DRAGON STANDARD  
R60, R80, R100, R120, R150**



**Read all instructions carefully before using the device and familiarize yourself with all the controls. In case of doubt, please contact the manufacturer.**

**Keep the instructions in a safe place that allows you to obtain the necessary information at any time.**

**REMET CNC TECHNOLOGY  
limited liability company  
36-053 Kamień, Łowisko 320A  
NIP 5170374653  
Original instructions**



## Table of Contents

1.	GENERAL SCHEME .....	3
2.	PURPOSE AND GENERAL DESCRIPTION OF THE APPLIANCE .....	5
3.	SPECIFICATION OF THE DEVICE .....	6
4.	SAFETY GUIDELINES AND INFORMATION ON AN EXISTING RISK MANAGEMENT .....	7
	General thoughts.....	7
	Personal protective equipment and pictograms.....	8
	Aggregation with the tractor .....	11
	Activities after finishing work.....	14
	Rules of conduct in emergency situations posing hazards to the life or health of employees....	15
5.	PROHIBITED ACTIONS.....	15
	Notes and first aid .....	16
6.	TRANSPORTATION AND STORAGE OF THE DEVICE .....	17
7.	MAINTENANCE AND CLEANING .....	17
	Safety instructions for maintenance. ....	17
	General activities related to maintenance and cleaning.....	17
8.	REPLACEMENT AND ADJUSTMENT OF AXLES .....	18
	Setting the axis of cutting knives in R-60, R-80, R-100 chippers .....	18
9.	REPLACEMENT PARTS AND ASSEMBLY .....	24
	Spare parts and assembly - model R-80.....	26
	Spare parts and assembly - model R-100.....	29
	Spare parts and assembly - model R-120.....	32
	Spare parts and assembly - model R-150.....	36
10.	DISPOSAL AND ENVIRONMENT PROTECTION.....	40
11.	SOLUTIONS FOR EXAMPLE PROBLEMS.....	40
12.	GUARANTEE CARD (based on proof of purchase).....	41
	PRINCIPLES OF THE WARRANTY GUARANTEE:.....	41
13.	DECLARATION OF CONFORMITY CE .....	41

# 1. GENERAL SCHEME

An overview diagram for the R-60 model

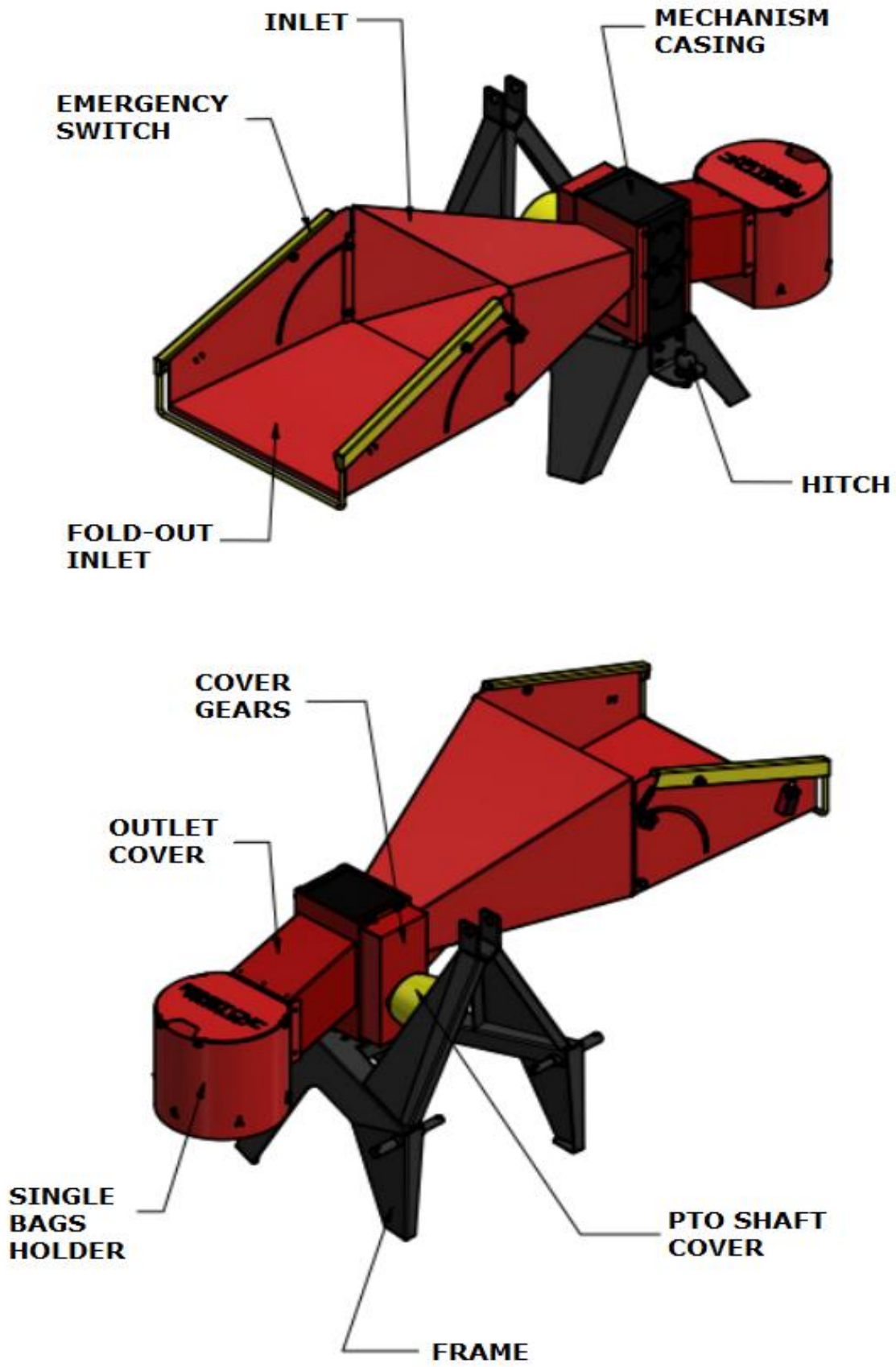

REMET CNC TECHNOLOGY SP. Z O.O.

An overview diagram for the R-80 - R-150 models

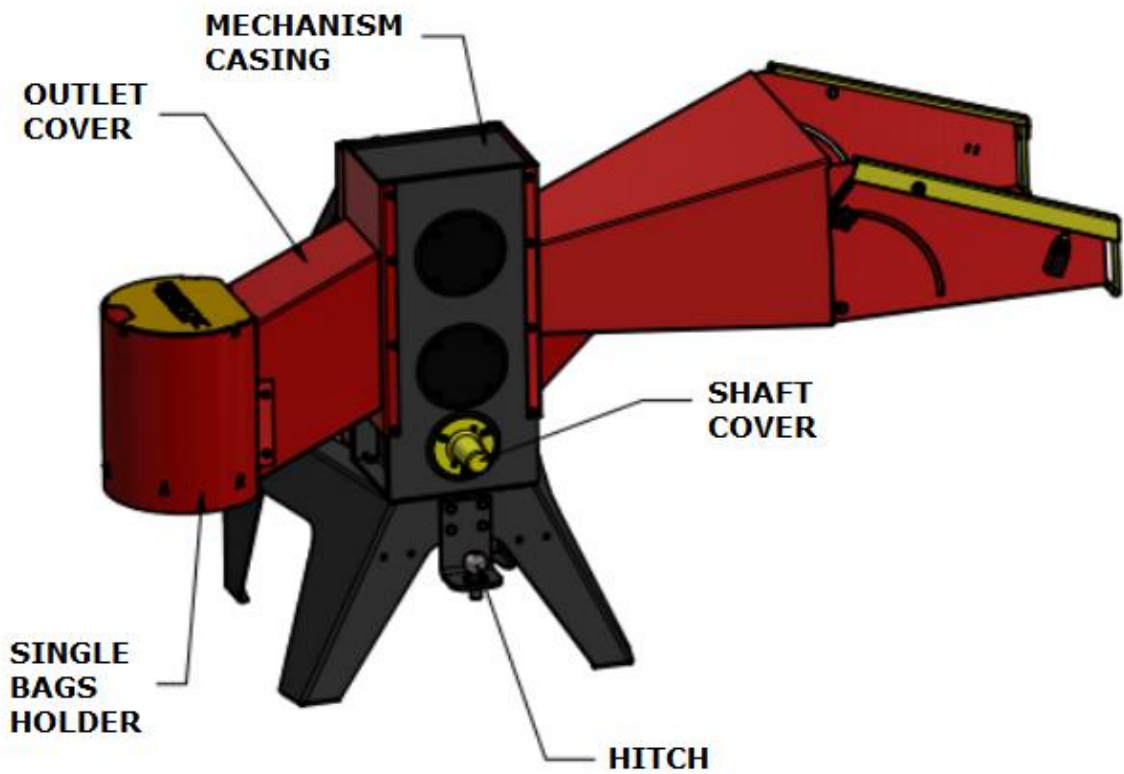
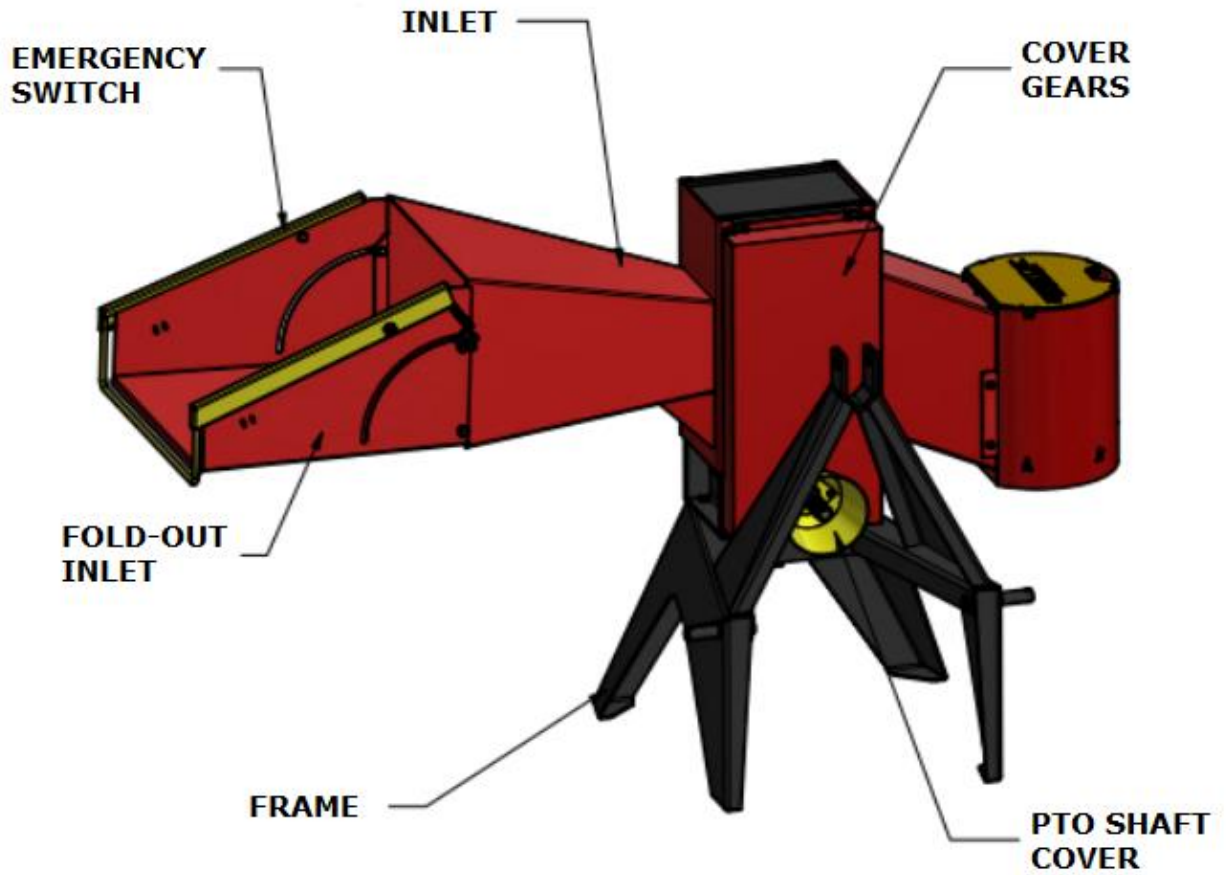

## 2. PURPOSE AND GENERAL DESCRIPTION OF THE APPLIANCE

The device is designed for woody shredding and fibrous garden waste such as tree branches and branches.



### **ATTENTION**

This symbol is used in this manual if there is a danger to the user or unauthorized persons.

This symbol is also used when there is a threat to the environment or property.

**ATTENTION:** It is forbidden to put stones, glass, metal, bone, plastic, textiles and other materials in the chipper mechanism feeder. Any use other than those approved in this manual may cause damage to the device and create a serious hazard to the operator. The operator or user bear the entire responsibility for the injuries and damage caused to third parties and their property. The manufacturer does not bear any responsibility for damages and unfortunate events caused by improper use and operation of the device, including any changes and modifications made by users and operators that also lead to immediate loss of warranty.

The chipper is equipped with a cylindrical cutting system (hardened knives made of high-speed steel). The housing of the mechanism is made of certified sheet metal with a thickness of 20 mm, shafts made of tempered steel, on which induction hardened gears are embedded. The mechanism automatically pulls in the material to be cut. The chipper has metal covers for the inlet and outlet feeder and gear wheels for safe operation. The solid construction on which the mechanism is embedded ensures durability and stability of the device.

INCORRECT OPERATION OF THE MACHINE MAY CAUSE BODY OR DEATH INJURY. BEFORE USING THE MACHINE, IT IS NECESSARILY READING



### 3. SPECIFICATION OF THE DEVICE

#### Technical parameters of chipper:

Typ	R60	R80	R100	R120	R150
Inner width [mm]	180	180	180	180	220
Distance between streams [mm]	60	80	100	120	150
Diameter of gears [mm]	150	150	180	200	280
Thickness of the housing [mm]	20	20	20	20	20
Recommended PTO shaft speed [rev / min]	to 540				
Recommended overload clutch [Nm]**	From 900 to 1300	From 900 to 1300	From 1300 to 1700	From 1300 to 1700	From 1700 to 2700
Minimum power [HP]	10	10	15	24	45
Recommended power [HP]	20	20	25	35	80
Max. cutting diameter of fresh softwood [mm] *	55	70	90	110	130
Max. cutting diameter of fresh hard wood [mm] *	50	60	80	100	130
Max. cutting diameter of dry hardwood [mm] *	40	50	70	90	110
Cutting length wood chips [cm]	4 knives: 9-15 6 knives: 5-10	4 knives: 9-15 6 knives: 5-12	4 knives: 9-18 6 knives: 7-14	6 knives: 8-15 8 knives: 5-10	6 knives: 12-18 8 knives: 10-15
Weight	120kg	130kg	145kg	170kg	290kg

\* The maximum diameter of shredded branches depends on the type of wood and the conditions when cutting the material. For hardwood (eg oak / beech), the maximum cutting diameter will be less than soft wood (eg pine, spruce). In the case of dry or gnarled wood, the maximum cutting diameter will also be reduced

\*\* The clutch selection parameter should be adjusted with max. the PTO's torque in the tractor

## 4. SAFETY GUIDELINES AND INFORMATION ON AN EXISTING RISK MANAGEMENT



### General thoughts

1. **The chipper must not be used by:**

- Unauthorized persons, untrained, not familiar with the instruction manual or under the influence of alcohol or narcotics and psychotropic substances (drugs) and drugs that impair the ability to react
- Children (below the minimum age of the operator defined by local regulations),
- Pregnant women,
- People with limited mental abilities.
- Only one operator, without the tractor operator who controls the PTO drive.

2. Before starting the device for the first time, the operator should familiarize himself with the operating instructions issued by the device manufacturer and make sure that it knows the operation of all control devices.

3. In addition, employees handling the chipper must have appropriate qualifications and have appropriate health and safety training in order to learn about safe rules and proper service

4. In order to perform the chipper operation, two trained persons are required, the chipper operator and the operator of the driving tractor, which in the event of a failure or threat to the life and health of the chipper operator, disconnects / disables the PTO drive shaft in the tractor.

5. Operators must provide sufficient space and hardened and a non-slippery surface to work with the device. And work only in daylight or very good artificial lighting.

6. Operators performing work with chipper should constantly observe the area of works and should never allow anyone or animals to stay in the working zone of the machine.

7. The chipper operators are responsible for the safety of unauthorized persons or animals that may be near the machine.

8. Works with the wood chipper can be performed only by adults, trained by the employer.

9. A worker who works using a chipper must be rested, healthy, in good physical condition.

10. Do not work during rain and bad weather

11. Do not overload the device.

12. Work wisely and take regular breaks.

13. It should be ensured that the chipper knives are always sharp.

**Incorrect use of the device can cause serious injury.**

**Personal protective equipment and pictograms**

When working with the wood chipper, use:

- safety goggles
- hearing protectors
- protective gloves
- protective footwear
- protective clothing, close fitting to the body, without loose protruding straps or sleeves.



Mark	Description	Mark	Description
	Use hand protection		No admission to outsiders!
	Use foot protection		Do not put your hands into the feeder's oil, Keep a safe distance from the inlet and ejection area
	Put on safety goggles		Attention! Danger of injury due to rotating cutting rollers. Keep your hands and feet away from the openings while the machine is running.
	Use hearing protection		Attention, the ability to cut your fingers / hands!
	Familiarize yourself with the instruction manual		Attention danger of being caught / drawn / entangled! Rotating elements!
 <b>OBYWIAZEK SMAROWANIA</b> <b>GREASE DAILY</b>	Obligation to lubricate the gear transmission		Attention danger!
	Max. speed and direction of rotation of the power take-off.		Rotating parts, danger of being caught.





**UWAGA!**

- ZAWSZE PRZESTRZEGAJ PRZEPISÓW I ZASAD BHP
- STOSUJ ODDZIAŁ OCHRONNĄ I ŚRODKI OCHRONY INDYWIDUALNEJ
- URZĄDZENIE MUSI BYĆ WYPOSAŻONE W OSŁONY BEZPIECZEŃSTWA
- SPRAWDZAJ MOCOWANIE ELEMENTÓW TRĄCZYCH (PRZY WYŁĄCZONEJ JEDNOCIE NAPIĘCIEJ)
- NIEODPOWIEDZIALNE JEST UŻYTKOWANIE MASZYNY NIEODPOWIE Z JEGO PRZEDZACZNIEM
- PRZEPROWADZAJ KONSERWACJE PRZEKŁADNI I ZĘBATEJ
- NIEWŁAŚCIWE UŻYTKOWANIE MOŻE BYĆ PRZYCZYŃĄ USZKODZENIA MASZYNY ORAZ DOPROWADZIĆ DO POWAŻNYCH OBRAŹEN CIAŁA



**⚠ DANGER ⚠ WARNING**

**CE** REMET CNC TECHNOLOGY Sp. z o.o.  
 ul. Łowisko 320A  
 36-053 Kamień  
 POLSKA, www.remetcnc.com

Waga: 290 kg    Moc minimalna WOM 33 kW  
 Moc zalecana WOM 59 kW

Rok produkcji: 2019    Napęd: WOM  
 max. 540 obr./min

Typ: R-150    Seria 19R150 STANDARD

**Rebak walcowy do ciągnika.**



**OBOWIĄZEK SMAROWANIA**  
**GREASE DAILY**

**max. 540 rpm**



## Safety switch

The chipper is equipped with a safety switch, which is mounted on the inlet sleeve cover. Before each commencement of work, the correct operation of the safety switch must be checked. If the tractor engine or the PTO shaft relay is activated with the safety switch pressed, do not start work before the failure is removed by a qualified employee.

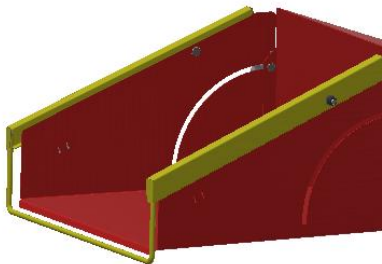

The safety switch must be compressed / connected to the emergency safety switch module on the tractor. The method of interruption of work depends on the integral protection systems of the tractor.

The safety switch installed at the chipper inlet is an extension of the emergency stop / safety systems of the tractor.

The safety switch when it is switched on has the character of a short-circuit constant. After removing the failure or averting the danger in order to proceed with further work, physically unlock the circuit breaker, "pulling out" yellow locking button.

## Things to do before starting work

Before commencing work, it is necessary:



1. Inspect the chipper before each use. Check that the safety system (if it is in the tractor, for example) and the drive system are functioning correctly. Do not start work if the chipper or driving device is not working properly or is damaged.
2. Check the gear lube condition in case of lack or insufficient lubrication, the gear unit should be greased.
2. Before commencing work, it is necessary to make sure that all covers are correctly fixed (check the tightening of the screws).
3. Machines should be placed on an even, hard, non-slippery surface with extreme caution.
4. Before commencing grinding, make sure that there are no bystanders or animals near the machine.

5. Before switching on the engine in the tractor, check the chipper attachment.
6. Wear a helmet or other covering covering the hair, safety glasses, hearing protection and protective clothing. The person operating the machine should not wear a scarf, tie, too loose clothing (clothes recommended strictly)
7. Damaged or illegible stickers must be replaced.



### **Aggregation with the tractor**

1. Observe the recommended minimum front load of the tractor in order to maintain stability.
2. Be especially careful when coupling the chipper with the tractor and during its disconnection.
3. Every time before starting work, check that all safety switches are working correctly.
4. It is strictly forbidden to stay between the chipper and the tractor and in the near distance while operating the lever to operate the hydraulic system.
5. It is forbidden to stay anybody between the tractor and the chipper during work.
6. Only use PTO shaft with cover. Work with a shaft without cover or with a damaged cover is strictly prohibited.
7. The shaft guard must be secured against rotation, eg with a chain.
8. Work without WPM guard (power take-off shaft in the machine) and PTO (power take off shaft in the tractor) is prohibited.

## Matching the transmission shaft of power

To ensure compatibility with a variety of 3-point fastening systems, the power transmission shaft may be too long or too short. It is particularly important that the transmission of the telescopic shaft through the telescopic shaft takes place freely, but without hammering to limit the working range.

**Too long shaft may cause damage to the bearings, too short, damage to the PTO shaft journal.**

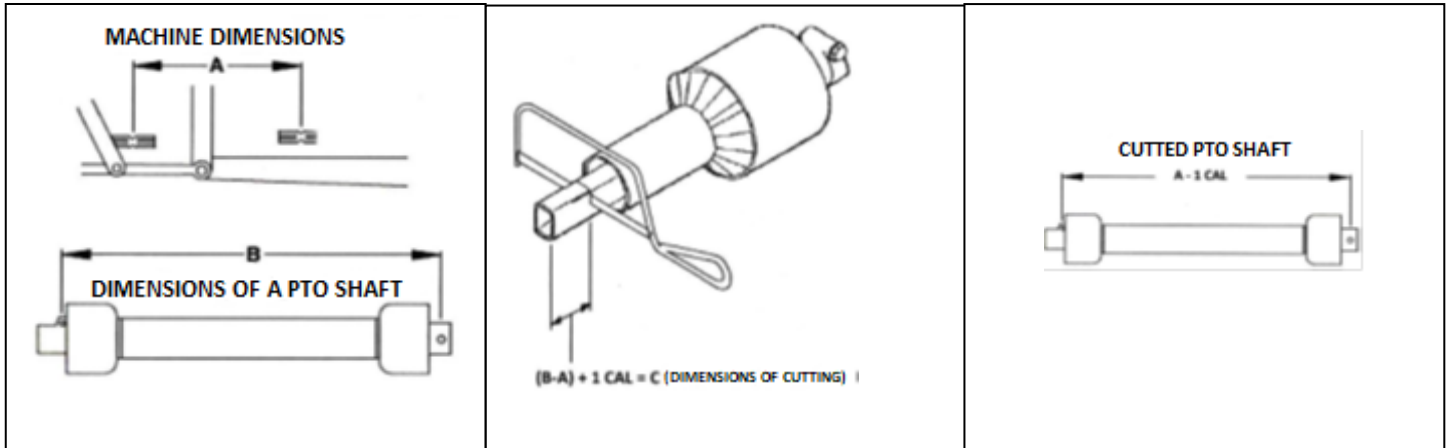

### **A. Determination of length:**

1. It is necessary to remove bystanders and animals from the device area.
2. Connect the crusher to the tractor, without the power transmission shaft.
3. Raise the shredder to equalize the PTO shaft levels.
4. Measure the dimension between the retaining grooves between the PTO shaft in the tractor and the PTO shaft in the shredder.
5. Measure the same dimensions on the compressed drive train (PTO shaft)
6. In case the power transmission shaft exceeds the measured dimension from point 4, shorten the shaft.

### **B. Cutting the telescopic shaft of power transmission:**

1. Cut the machine dimension (A) to the cut dimension of the drive system (B) or (B-A). This dimension determines if the drive system is too long.
2. Add an additional inch (25mm) to this dimension so that the system does not punch to the working dimension, set the cut-off dimension (C)..
3. Cut the dimension (C) at both ends with a metal ball. Cut the plastic bushings as well.
4. Destroy the resulting sharp edges.
5. Assemble the shaft.
6. It should be checked whether the connection of the PTO shaft takes place freely.



### **The rules of safe work performance**

1. Before starting work, make sure that the inlet and outlet funnels are empty.
2. **During work** and **immediately after switching off**, do not touch the discharge channel, do not put your hands into the feeder inlet (the device will work even for a short while after turning it off).
3. When working with a tractor that does not have an emergency switch to operate the device, two people are necessary, the operator of the tractor driving the chipper and the chipper operator.
4. Operators must provide sufficient space and hardened and a non-slippery surface to work with the device. And work only in daylight or very good artificial lighting.
5. Operators must also ensure a good balance and stability. Do not lean forward or stand above the device when inserting material.
6. When working, keep your head, hair and body away from the opening and use protective goggles, hearing protection and protective clothing.
7. Operators performing work with chipper should constantly observe the work area and immediately stop work in the event of appearance of unauthorized persons or animals in the working area of machines.
8. Before inserting the material to be cut into the inlet hopper, pay attention to whether the material has no foreign elements harder than wood such as stones, wires, ropes, nails, rivets, chains, etc. that can damage the knives, cutting mechanism or the whole machine what  
consequently, it can lead to a dangerous accident that endangers the life and health of the operator and other third parties.
9. If the chipper cutting mechanism is blocked, the engine of the tractor driving the chipper must be stopped immediately.
10. In the case of hooking the clothes of the operator with the branches and pulling it towards the inlet of the chipper feeder, the tractor operator must immediately stop the tractor operation.
11. To protect against accidental switching on the tractor driving the chipper, remove the key from the ignition or disconnect the battery by removing the clamp from the clamp.

12. The drive of the wood chipper must be switched off during each interruption.

13. When the cutting system is working even for a certain period of time, it is prohibited to transport, move or lift.

14. To avoid jams, one should alternately insert limp and thin material with larger branches.

15. Turn the device off when the entire material has passed through the crushing roll. Otherwise, the device may jam.

16. During operation, keep a safe distance from the device, because long branches can be thrown out during the retraction.

### **Getting the machine out :**

Despite the lack of working restrictions for the first start of the wood chopper, the following checks are recommended:

**1. After working for 1 hour:**

- Check tightness of all screws,
- Check the condition of the bearings,
- Check the condition of the cutting blades. Adjust or replace if necessary.
- Lubricate the gear unit.

**2. After working every next 10 hours:**

- Repeat the above steps.

### **Activities after finishing work.**

1. After switching off the drive, wait a short time, because the rotating parts of the mechanism are still working for some time after the drive is switched off.

2. Make sure that the machine is able to stop completely and then perform activities related to the cleaning and maintenance of the machine.

3. Set the machine down and secure it in the parking spot.

4. Checking the technical condition, regulating and performing temporary repairs and maintenance works as well as cleaning of parts and working units can be carried out only when the chipper has switched off the drive.

5. Periodically checks that all screws and nuts are tight. Damaged replace.

6. When changing the damaged chipper knife, always tighten or loosen the knife using protective gloves and following the instructions in section 9.

**Rules of conduct in emergency situations posing hazards to the life or health of employees.**



1. After identifying the defects, damage or improper operation of the machine or its subassemblies, chopper immediately shut down and immobilize and inform your supervisor. Resumption of work without removing the damage or the cause of the failure is unacceptable.
2. If it is necessary to leave the wood chipper during unattended operation, switch off the tractor and immobilize the machine.
3. In case of doubts as to the preservation of work safety conditions, the employee has the right to stop work and ask the supervisor for an explanation of the situation and decision.
4. In the event of an accident at work, switch off the tractor driving the machine, report the accident to the supervisor, call an ambulance, if necessary. Leave the workplace in the same state in which the accident occurred.
5. In case of doubts as to how to perform work, the work should be stopped and the supervisor should be asked for guidance.
6. In case of fire of the tractor driving the chipper. Proceed accordingly with instructions for fire-fighting.
7. Incorrect or damaged or remaining chipper should be withdrawn from use, and clearly marked with information boards and protected in a manner that prevents its launch.

**5. PROHIBITED ACTIONS**



1. **It is forbidden** work with a chipper after drinking alcohol or intoxicants and psychotropic substances (drugs) and drugs that reduce the ability to react.
2. **It is forbidden** use of the chipper by:
  - Children (below the minimum age of the operator defined by local regulations),
  - Pregnant women,
  - People with limited mental abilities.
3. **It is forbidden** starting work with a chipper without checking the technical condition of the device.

4. Operators **It is forbidden** distance from the chipper without first switching off the tractor engine and removing the key from the ignition switch or disconnecting the power supply.
5. **It is forbidden** make any adjustment of the chipper or perform repairs while the wood chipper is coupled with the tractor.
6. **It is forbidden** using the machine with removed or damaged safety devices such as covers and covers, pouring and ejection funnels and with missing warning stickers.
7. **It is forbidden** use the device for purposes other than those for which it is intended.
8. **It is forbidden** using the device while the tractor is moving
9. **It is forbidden** making any changes or modifications to the device, making changes or modifications results in immediate loss of the warranty. In addition, the manufacturer is not liable for resulting damage to property and injuries, death of the operator) resulting from changes or modifications to the device.

### **Notes and first aid**



1. Report any accident at work to your supervisor, leave the work station in the condition in which the accident occurred.
3. Always be prepared. Obtain the following instructions in:
  - A fully equipped first aid kit easily accessible by the operator and bystanders. The first aid kit should contain an appropriate amount of dressing for cuts and cut wounds.
  - Clean towels and cloths to stop hemorrhaging.
  - A cell phone or other device that allows you to quickly call for help.
4. Do not work alone! There should be a person in the vicinity who knows the rules of first aid. The midfielder must be at a safe distance from the work area, but he should always pay attention to the operator. Use the device only in places where you can quickly call an ambulance! If injury occurs first aid should be given and further medical help should be obtained if necessary.



## 6. TRANSPORTATION AND STORAGE OF THE DEVICE

The device should be transported after coupling with the tractor or on a suitable platform of this type.

The device should be stored out of reach of children in a dry place at 0°C to + 40°C.

## 7. MAINTENANCE AND CLEANING



### **Safety instructions for maintenance.**

The device must be disconnected from the power source and placed on a stable, even and non-slippery surface before carrying out maintenance or repairs. Clean the device before and after each use, and check the tightness of the screws that secure the covers.

### **General activities related to maintenance and cleaning**

The device should be kept clean at all times. To clean the device, use only a brush or cloth. Never use any solvents or cleaning agents.

Check all covers and protective elements are undamaged and in the correct place. Replace if necessary. Pay special attention to loose and worn parts. Check for screws

and the nuts are tight.

Before every use, check the gear lube condition. A graphite grease is recommended for the lubrication of a gear transmission.

## 8. REPLACEMENT AND ADJUSTMENT OF AXLES

Before you set the blade axes or replace them, the device should be disconnected from the power source and placed on a stable, even and not slippery ground. When sharpening knives, wear goggles and protective gloves (machine sharpened), damaged blades should be replaced with original ones, recommended by the manufacturer. If the cutting blades are not on the axis, i.e. they pass instead of converging, please follow the below schemes depending on the type of device



### Setting the axis of cutting knives in R-60, R-80, R-100 chippers

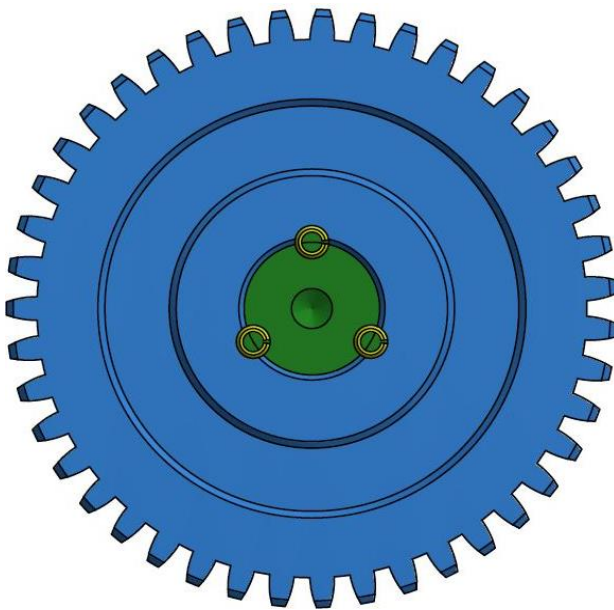

Diagram of the correct position of the cutting roller relative to the pinion. Security pins intact / undamaged

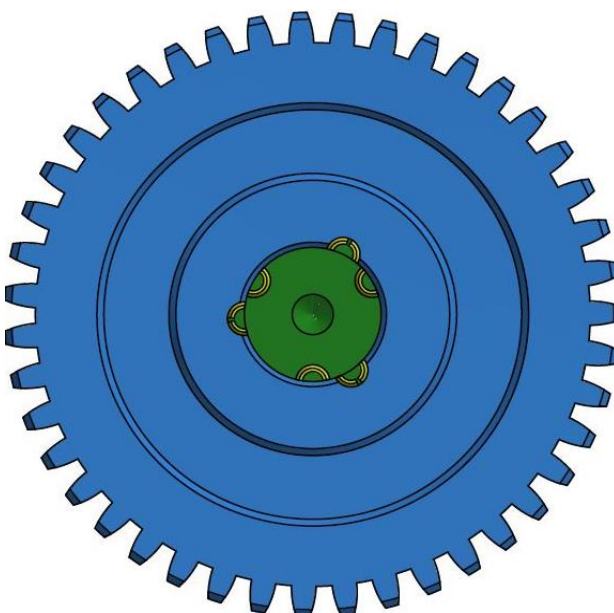

Diagram of the incorrect position of the cutting roller relative to the pinion. Security pins broken / cut.

It is necessary to remove the gear from the cutting roller. Removal of pin remains.

Then set the gear in the original position and check the axuality of the knives, in the case of lack of alignment, drill new holes for the safety pins to align the position of the cutting knives

Setting the knife axis is described **step 6.**

## Setting the axis of cutting knives R-120, R-150

If you move the blade axis relative to each other, do the following:

Step 1. Unscrew the M8 / M10 Allen screws by 3-5 mm from the upper part of the clamping sleeve:

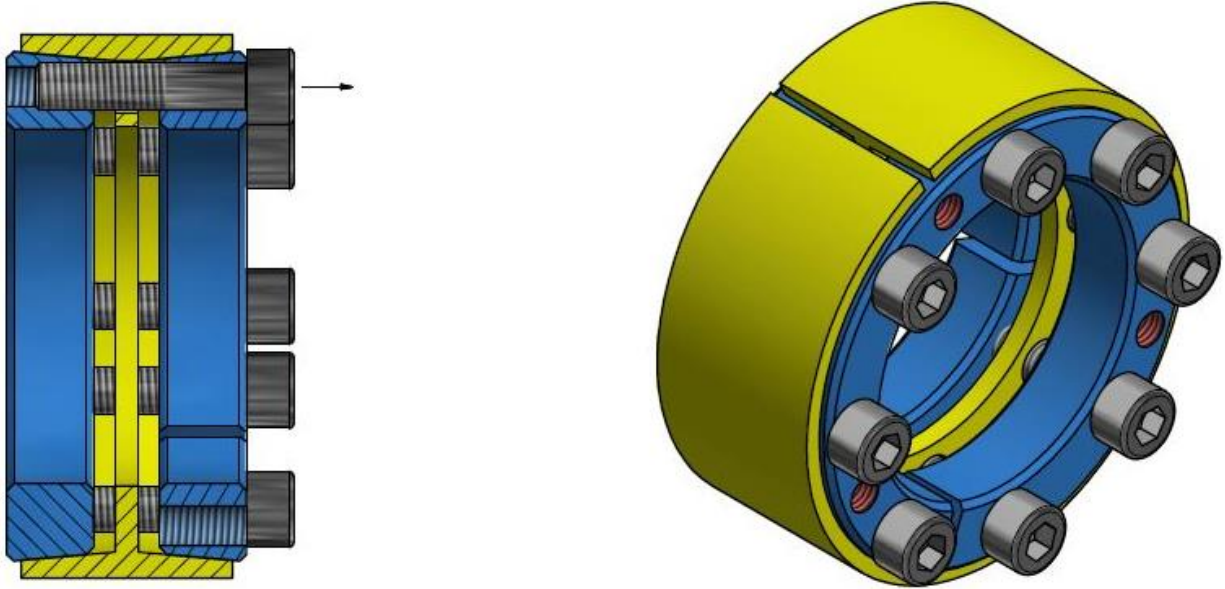

Step 2. Hit the bolts with great force until the lower part of the clamping sleeve is unblocked, hit through a piece of thick sheet for even pressure and to avoid damage to the bolts

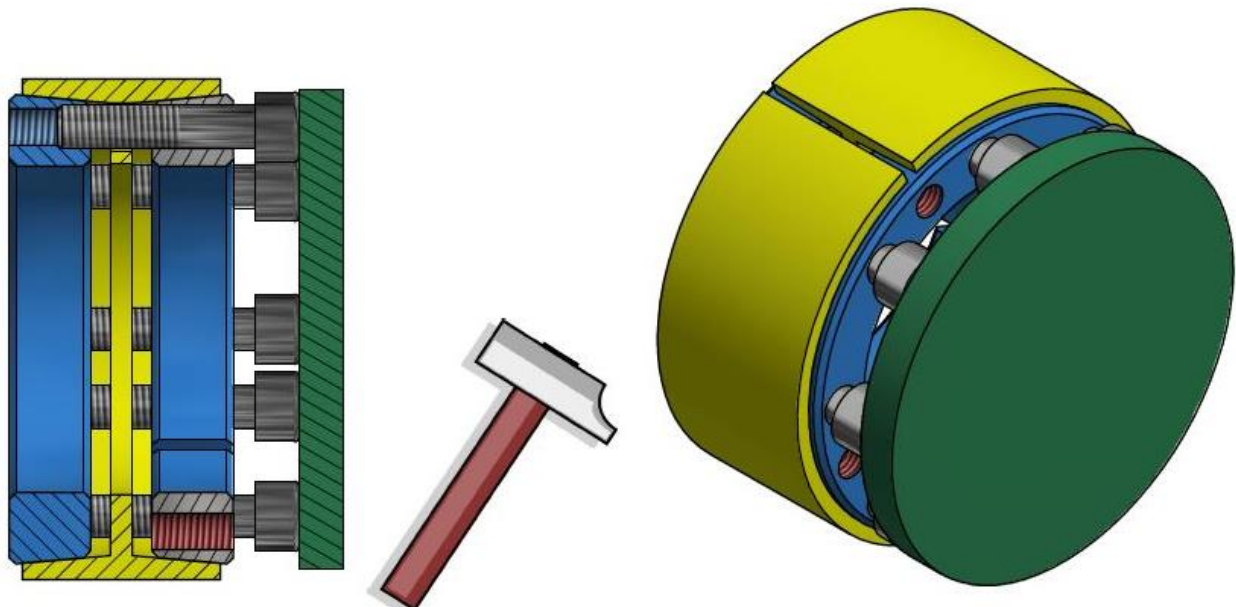

Step 3. After unlocking the lower part of the clamping sleeve, the 3 bolts must be completely unscrewed, while the remaining bolts should be unscrewed as much as possible, but not completely (to avoid fully disconnecting the bush elements):

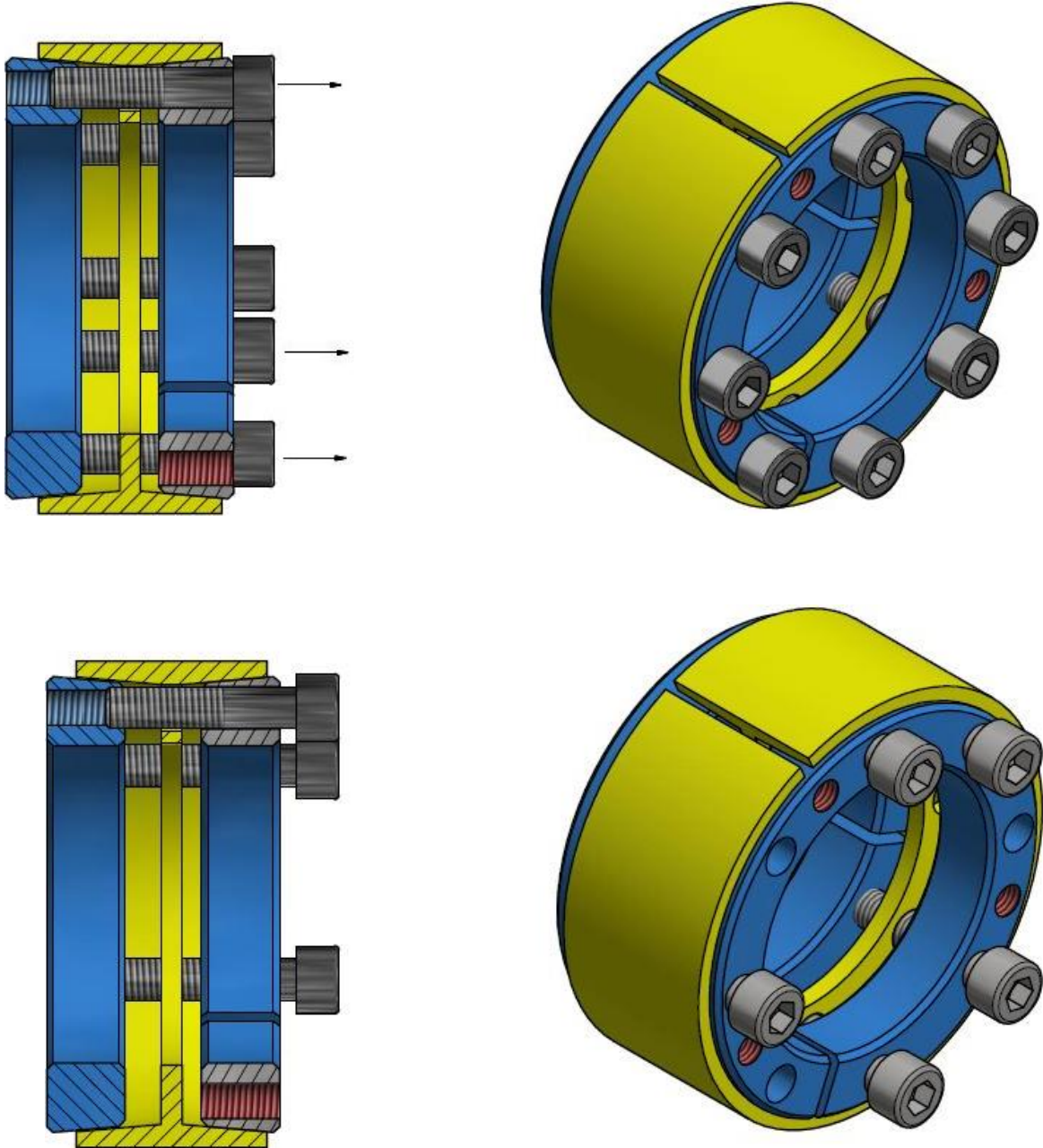

Step 4. Using the previously screwed screws, three of them must be screwed into three threaded holes used to unblock the upper part of the clamping sleeve:

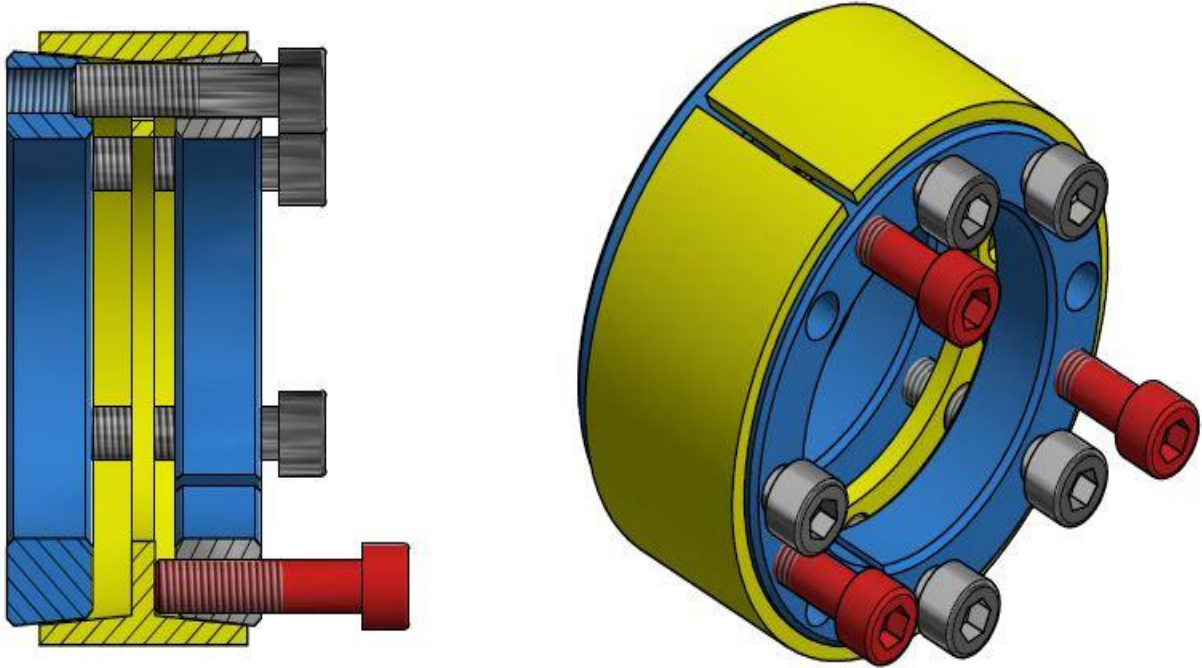

Step 5. Gradually tighten the opposite bolts until the upper part of the clamping sleeve is fully unblocked:

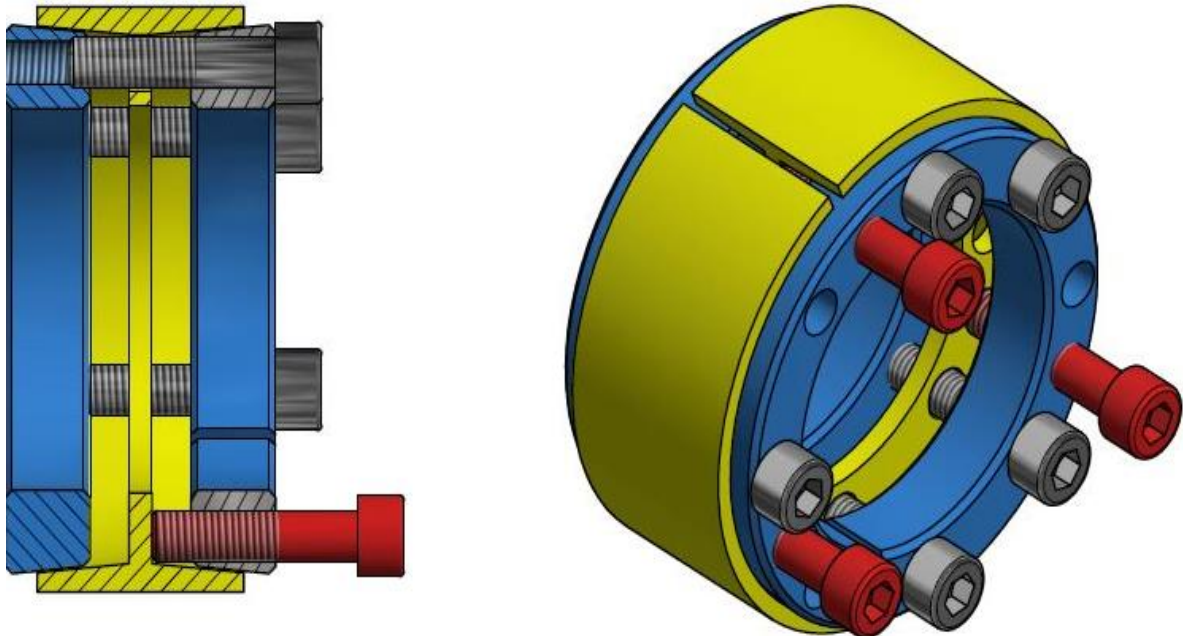

Step 6. To position the cutting rollers in the correct position, lock the cutting rollers with the blade axis as shown below:

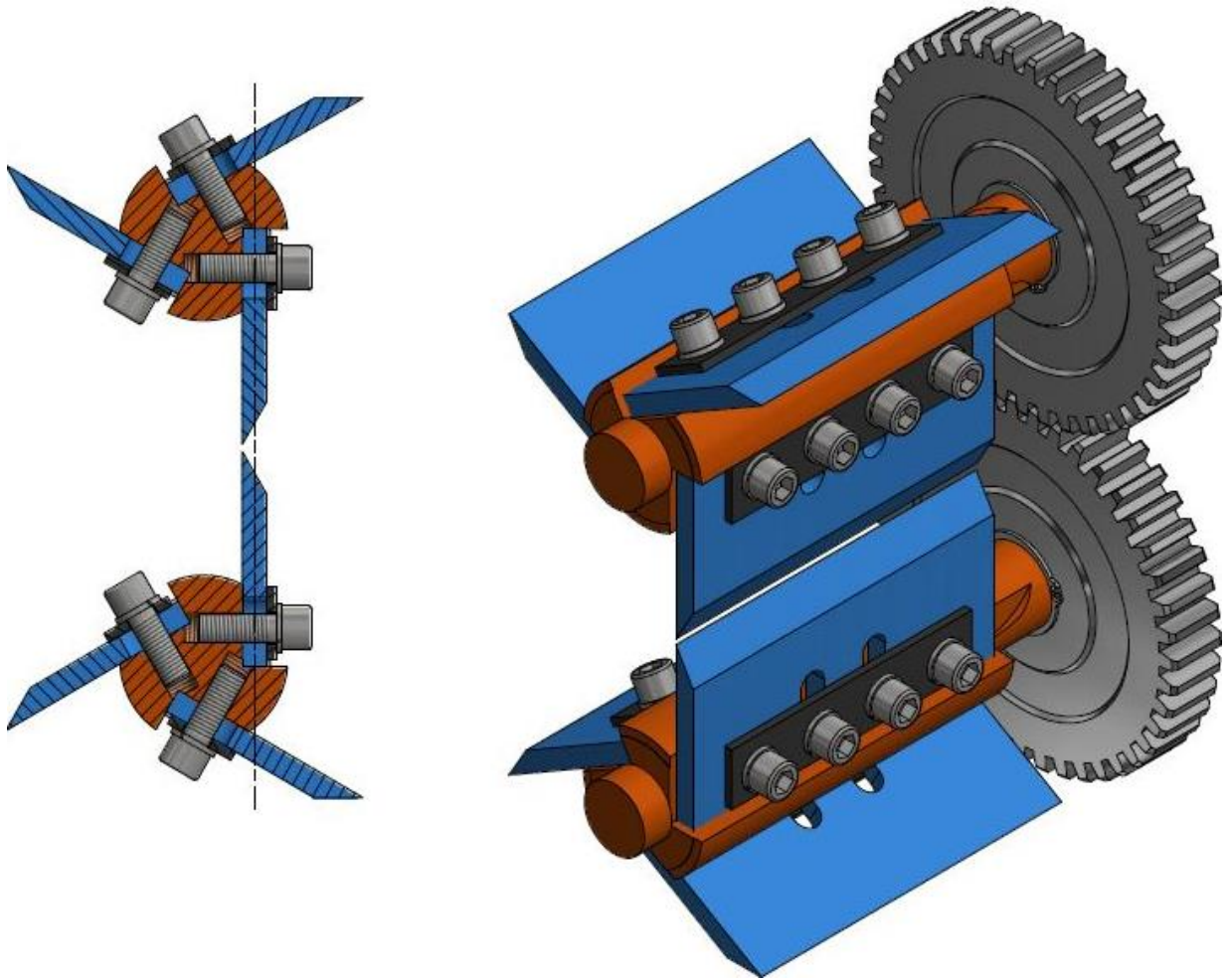

Step 7. With the rollers locked, tighten the clamping bolts evenly and evenly, continue tightening until the faces of the outer and inner rings face the face:

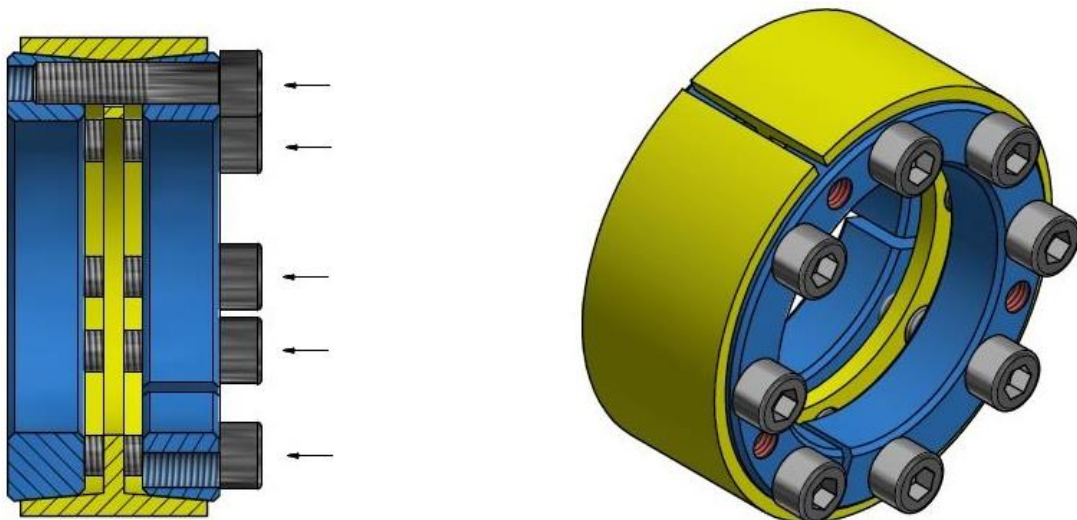

Step 8. The blades should be set to 0.2 mm clearance according to the following scheme:

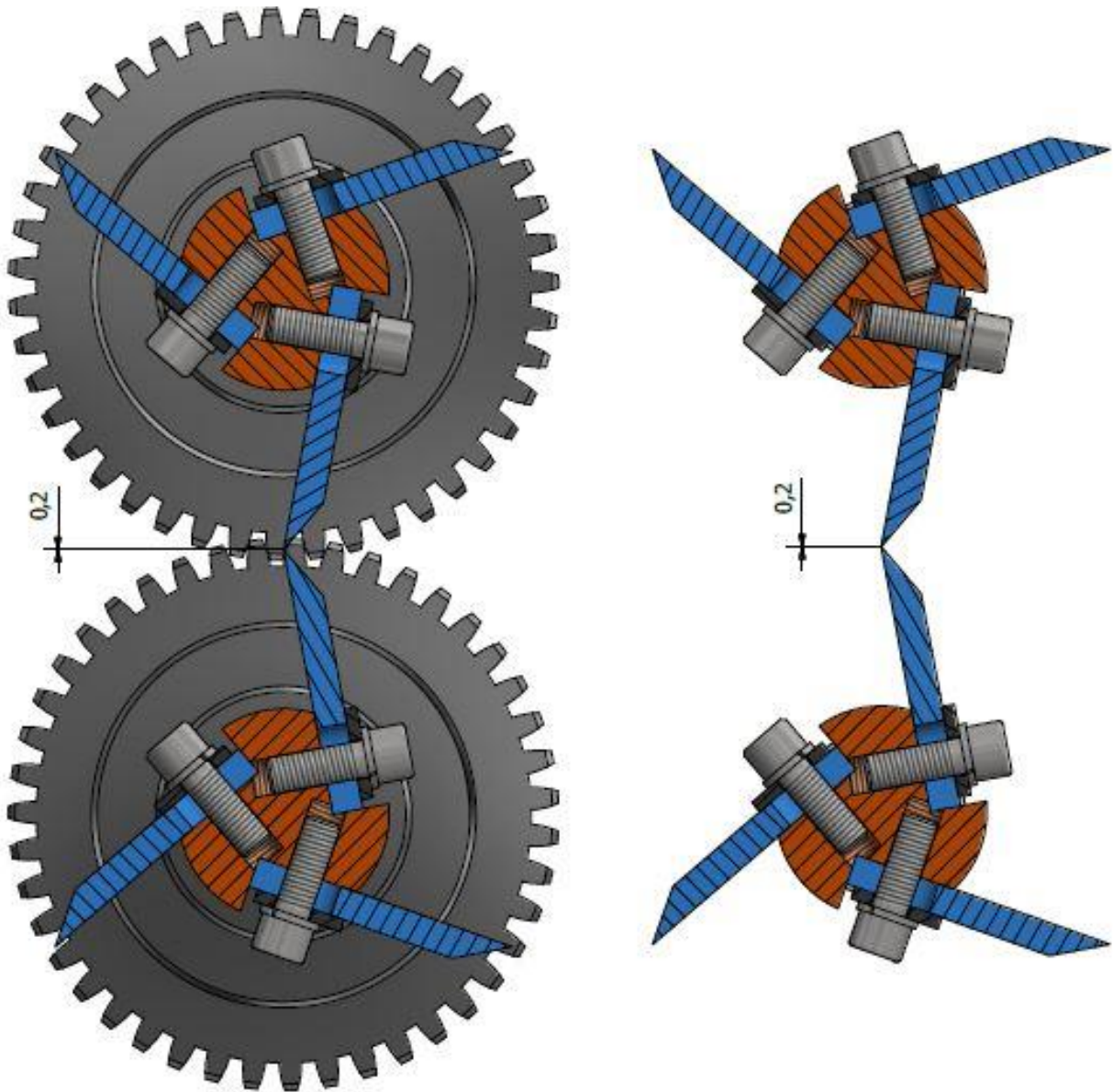

## 9. REPLACEMENT PARTS AND ASSEMBLY

Replacement parts can be ordered directly from the manufacturer. When ordering please specify the device type and part number.

### Spare parts and assembly - model R-60

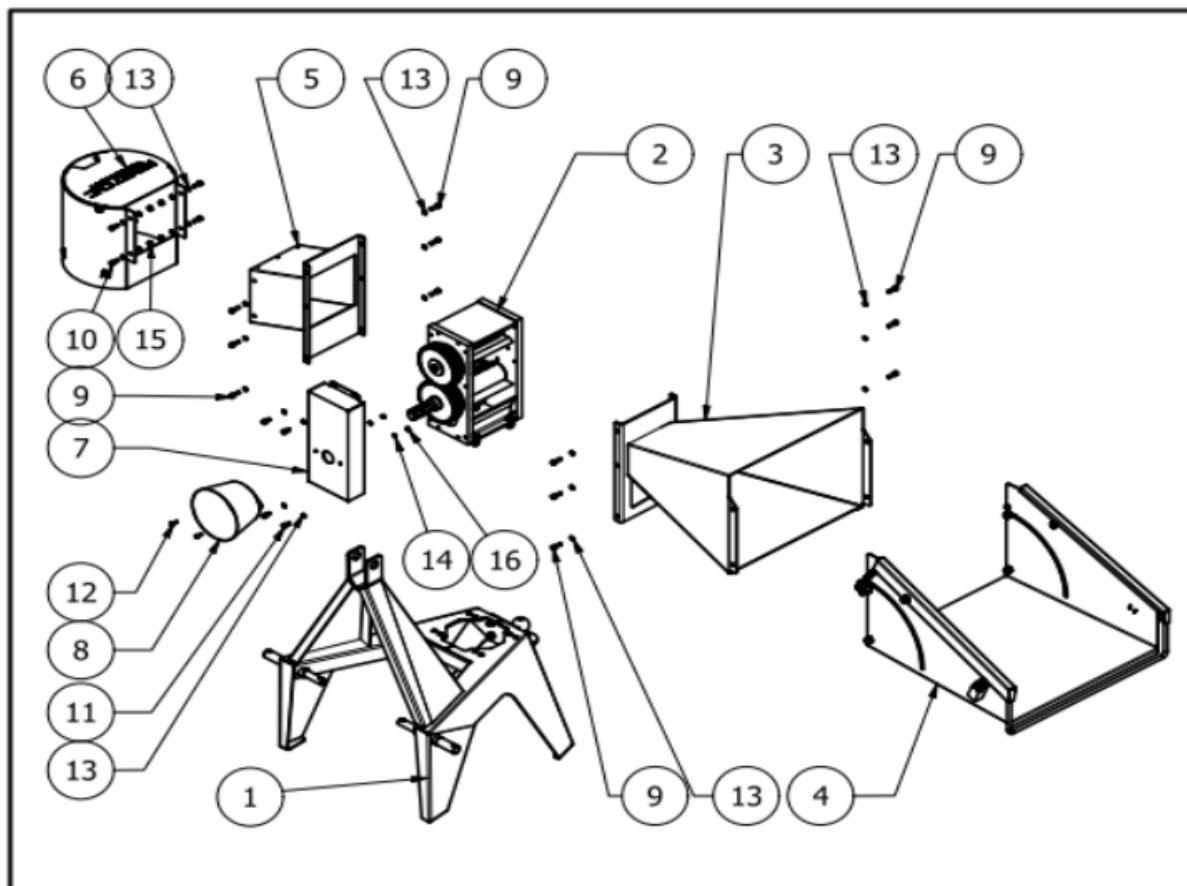

LISTA CZĘŚCI

Lp.	Ilość szt.	Numer części/norma	Nazwa
2	1	R60-00-00	Mechanizm
3	1	R60-00-00	Wlot
4	1	R60-00-00	Dokładka
5	1	R60-00-00	Wylot
6	1	R60-00-00	Workownica
7	1	R60-01-00	Ośłona kół zębatach
8	1	R60-02-00	Ośłona WOM-u
9	12	PN-87/M-82302	Śruba z gniazdem sześciokątnym M8x25
10	4	PN-87/M-82302	Śruba z gniazdem sześciokątnym M8x20
11	4	PN-87/M-82302	Śruba z gniazdem sześciokątnym M8x16
12	2	PN-85/M-82105	Śruba z łbem sześciokątnym M6x16
13	24	PN-77/M-82008	Podkładka sprężysta 8,2
14	2	PN-77/M-82008	Podkładka sprężysta 6,1
15	2	PN-86/M-82144	Nakrętka M8
16	2	PN-86/M-82144	Nakrętka M6



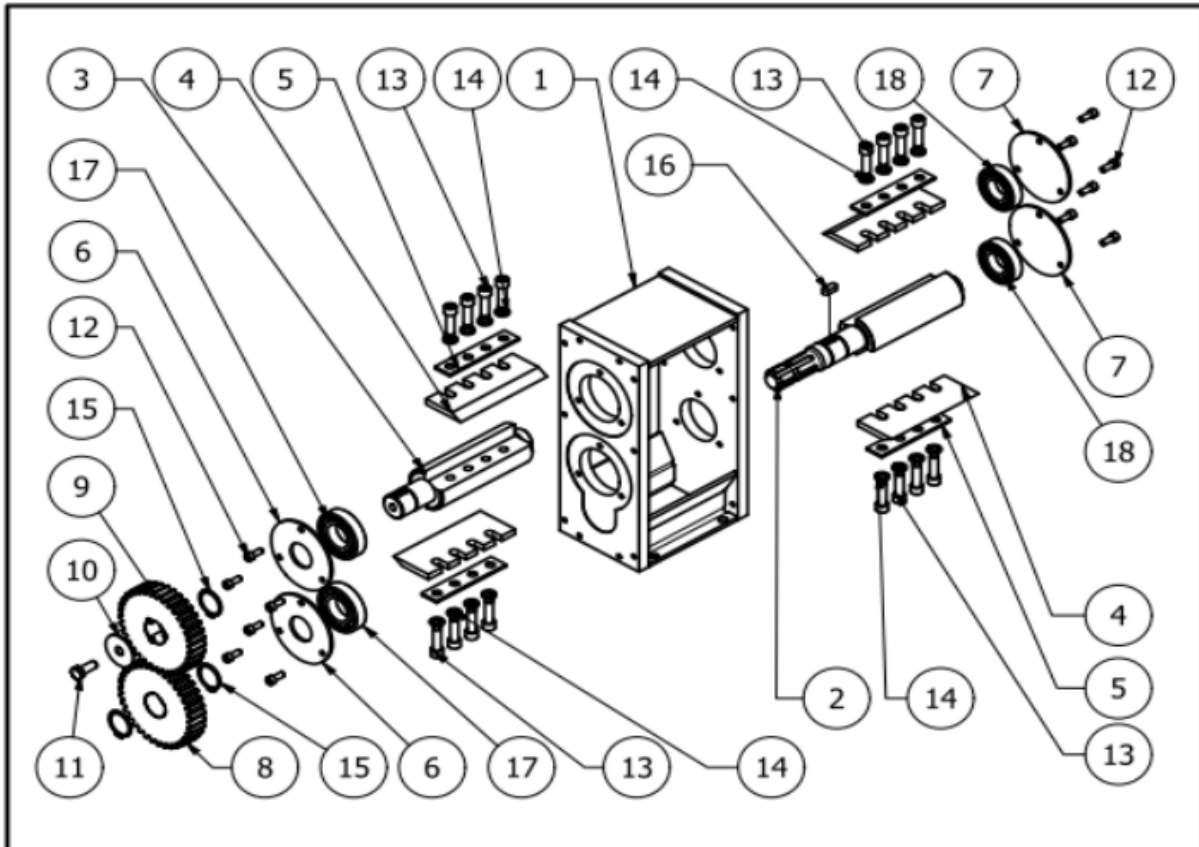

LISTA CZĘŚCI

Lp.	Ilość szt.	Numer części/norma	Nazwa
1	1	R60.010000-001.A	Korpus obrobiony
2	1	R60.010000-05	Walek napędowy
3	1	R60.010000-04	Walek górny
4	4	R60.010000-06	Nóż R60,R80
5	4	R60.010000-07	Docisk noża
6	2	R60.010000-08	Dekielek 1
7	2	R60.010000-09	Dekielek 2
8	1	R60.010000-10	Koło zębate z wpustem
9	1	R60.010000-11	Koło zębate
10	1	R60.010000-12	Podkładka pod koło
11	1	PN-85/M-82105	Śruba z łbem sześciokątnym M12x30
12	12	PN-87/M-82302	Śruba z gniazdem sześciokątnym M8x20
13	16	PN-87/M-82302	Śruba z gniazdem sześciokątnym M12x40
14	1	PN-77/M-82008	Podkładka sprężysta 12,2
15	12	DIN 471	Pierścień sprężynujący 40x1,75
16	1	PN-91/M-85001A	Wpust 10x8x25
17	2	PN-85/M-86100	Łożysko 6208
18	2	PN-85/M-86100	Łożysko 6207

**Spare parts and assembly - model R-80**

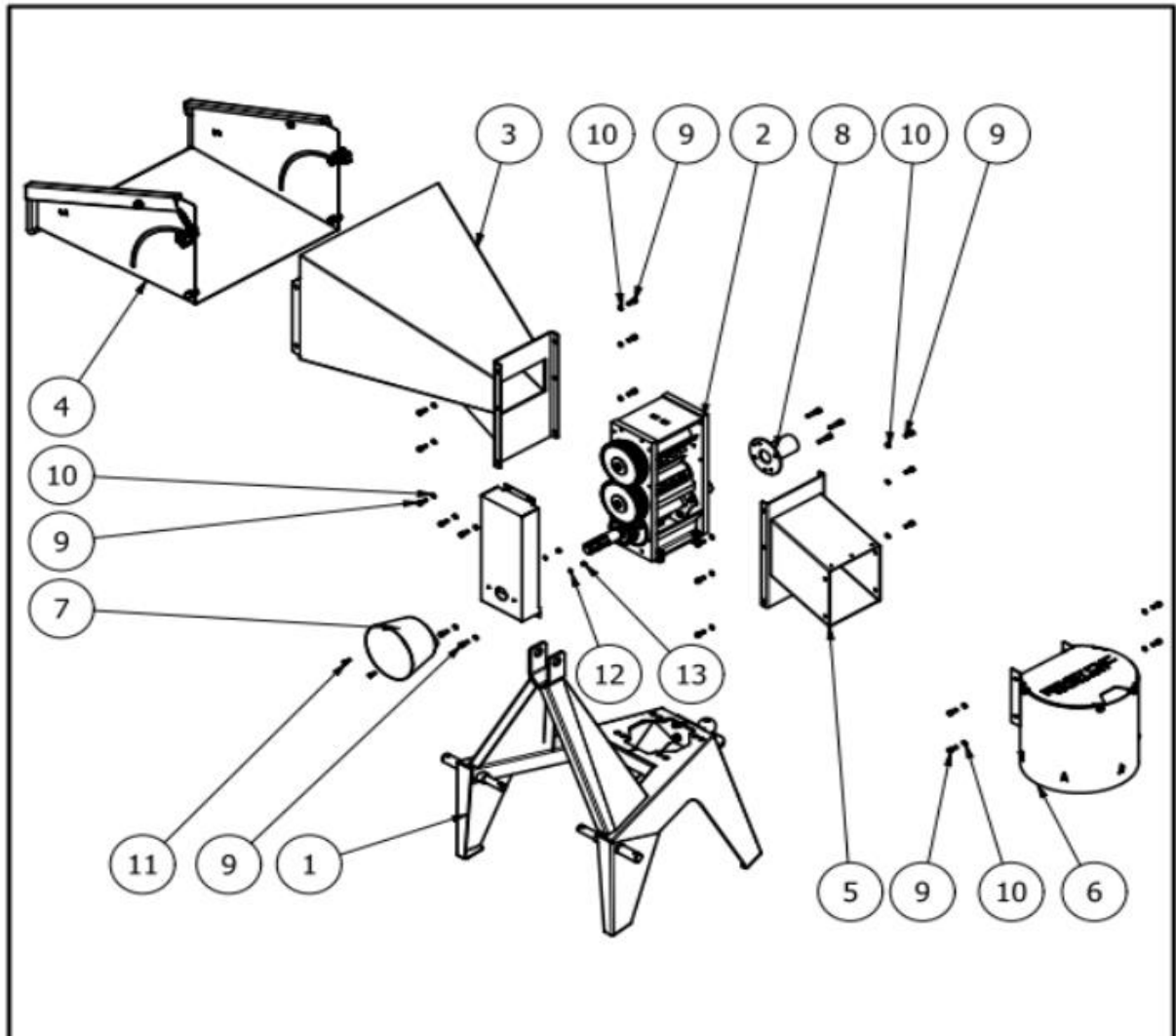

LISTA CZĘŚCI

Lp.	Ilość szt.	Numer części/norma	Nazwa
2	1	R80-00-00	Mechanizm
3	1	R80-00-00	Wlot
4	1	R80-00-00	Dokładka
5	1	R80-00-00	Wylot
6	1	R80-00-00	Workownica
7	1	R80-01-00	Oslona WOM-u
8	1	R80-02-00	Oslona wałka WOM
9	20	PN-87/M-82302	Śruba gniazdem sześciokątnym M8 x 20
10	24	PN-77/M-82008	Podkładka sprężysta 8,2
11	2	PN-85/M-82105	Śruba z łbem sześciokątnym M6x16
12	2	PN-77/M-82008	Podkładka sprężysta 6,1
13	2	PN-86/M-82144	Nakrętka M6

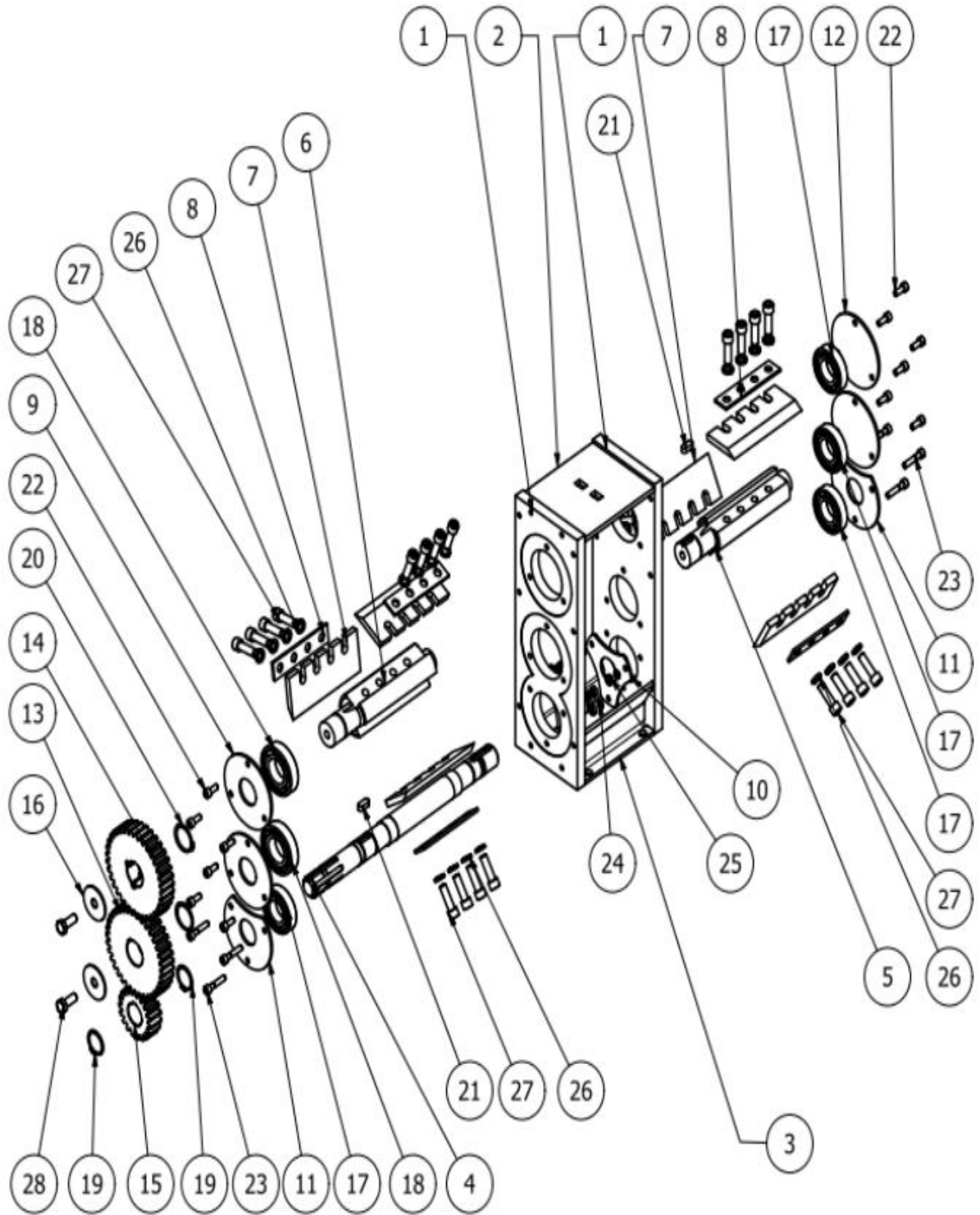

LISTA CZĘŚCI			
Lp.	Ilość szt.	Numer części/norma	Nazwa
1	2	R80.010000_01A/B	Blacha boczna korpusu
2	1	R80.010000_02	Blacha górna korpusu
3	2	R80.010000_03	Mocowanie korpusu
4	1	R80.010000_04	Wałek napędowy
5	1	R80.010000_05	Wałek tnący dolny
6	1	R80.010000_06	Wałek tnący górny
7	6	R80.010000_07	Nóż
8	6	R80.010000_08	Docisk noża
9	2	R80.010000_09	Dekielek 1
10	2	R80.010000_10	Dekielek 2
11	2	R80.010000_11	Dekielek 3
12	2	R80.010000_12	Dekielek 4
13	1	R80.010000_13	Koło zębate duże z wpustem
14	1	R80.010000_13A	Koło zębate duże
15	1	R80.010000_14	Koło zębate małe
16	2	R80.010000_15	Podkładka koła
17	4	PN-85/M-86100	Łożysko 6207
18	2	PN-85/M-86100	Łożysko 6208
19	2	DIN 471	Pierścień sprężynujący 35x1,5
20	2	DIN 471	Pierścień sprężynujący 40x1,75
21	2	PN-91/M-85001A	Wpust 10x8x25
22	12	PN-87/M-82302	Śruba M8x20
23	6	PN-87/M-82302	Śruba M8x40
24	6	PN-77/M-82008	Podkładka sprężynowa M8
25	6	PN-86/M-82144	Nakrętka M8
26	24	PN-77/M-82008	Podkładka sprężynowa M12
27	24	PN-87/M-82302	Śruba M12x40
28	2	PN-85/M-82105	Śruba M12x30

**Spare parts and assembly - model R-100**

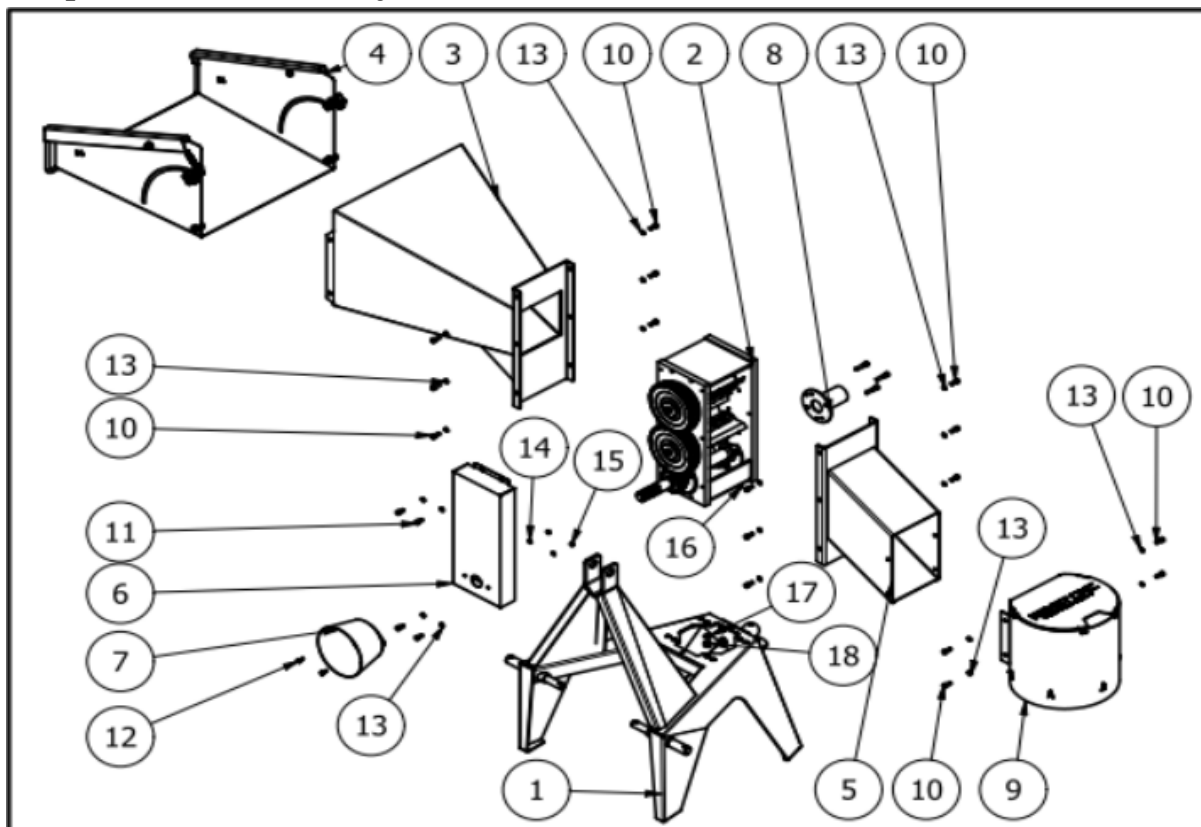

**LISTA CZĘŚCI**

Lp.	Ilość szt.	Numer części/norma	Nazwa
1	1	R100-00-00	Rama
2	1	R100-00-00	Mechanizm
3	1	R100-00-00	Wlot
4	1	R100-00-00	Dokładka
5	1	R100-00-00	Wylot
6	1	R100-01-00	Oslona kół
7	1	R100-02-00	Oslona WOM-u
8	1	R100-03-00	Oslona wałka
9	1	R100-00-00	Workownica R100
10	16	PN-87/M-82302	Śruba z gniazdem sześciokątnym M8x20
11	4	PN-87/M-82302	Śruba z gniazdem sześciokątnym M8x16
12	2	PN-87/M-82302	Śruba z gniazdem sześciokątnym M6x16
13	24	PN-77/M-82008	Podkładka sprężysta 8,2
14	2	PN-77/M-82008	Podkładka sprężysta 6,4
15	2	PN-86/M-82144	Nakrętka M6
16	4	PN-85/M-82105	Śruba z łbem sześciokątnym M12x30
17	4	PN-77/M-82008	Podkładka sprężysta 12,2
18	4	PN-86/M-82144	Nakrętka M12

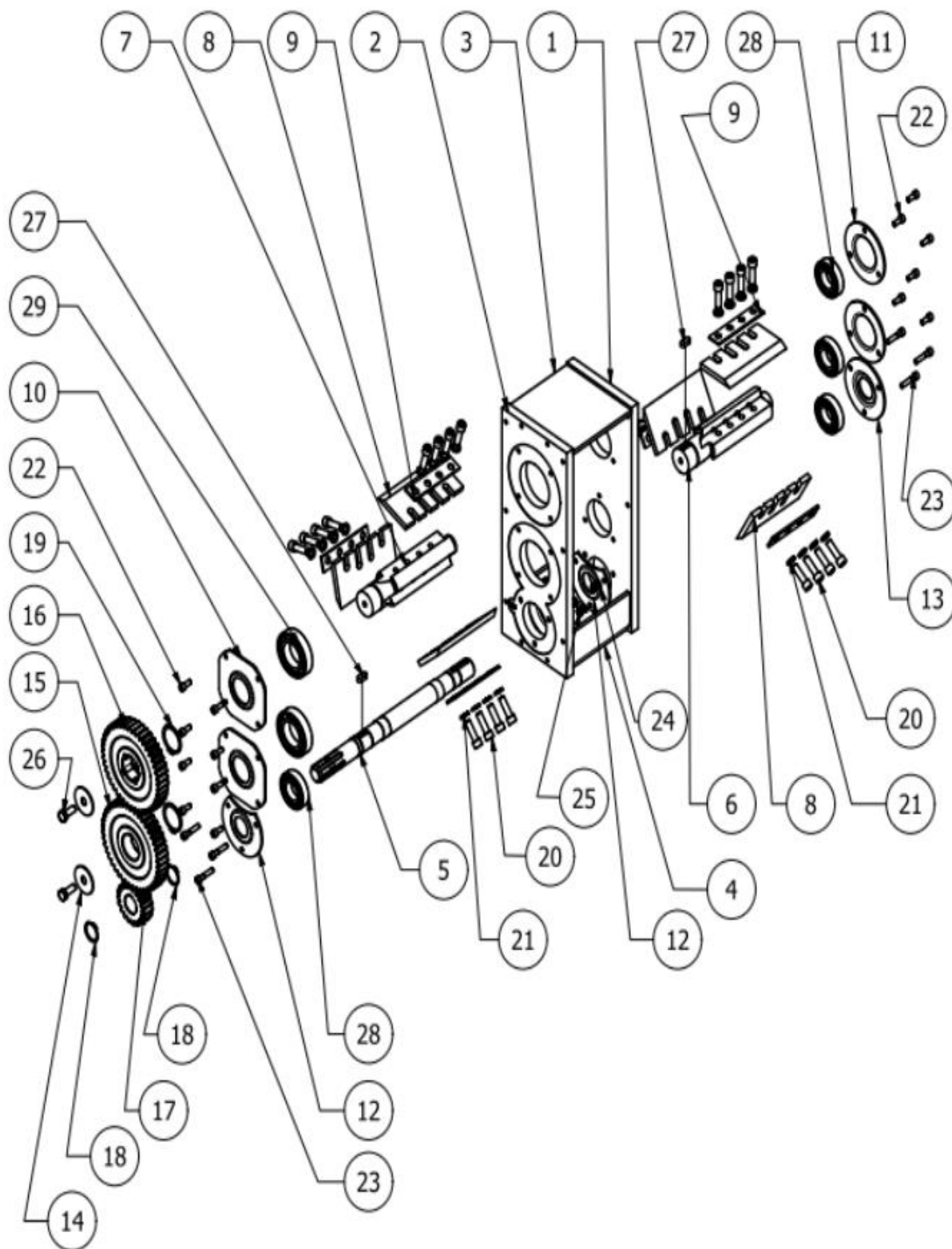

REMET CNC TECHNOLOGY SP. Z O.O.

LISTA CZĘŚCI			
Lp.	Ilość szt.	Numer części/norma	Nazwa
1	1	R100.010000-01	Blacha boczna 1
2	1	R100.010000-02	Blacha boczna 2
3	1	R100.010000-03	Blacha górna
4	2	R100.010000-04	Płaskownik mocujący
5	1	R100.010000-05	Wał napędowy R100
6	1	R100.010000-06	Wałek tnący dolny
7	1	R100.010000-07	wałek tnący górny
8	6	R100.010000-08	Nóż R100
9	6	R100.010000-09	Podkładka pod nóż
10	2	R100.010000-10	Dekielek 1
11	2	R100.010000-11	Dekiel 2
12	3	R100.010000-12	Dekiel 3
13	1	R100.010000-13	Dekiel 4
14	2	R100.010000-14	Podkładka pod koło
15	1	R100.010000-15	Koło zębate duże wpust
16	1	R100.010000-16	Koło zębate duże
17	1	R100.010000-17	Koło zębate małe
18	2	DIN 471	Pierścień sprężynujący 35x1,5
19	2	DIN 471	Pierścień sprężynujący 50x2
20	24	PN-87/M-82302	Śruba z gniazdem sześciokątnym M12x40
21	24	PN-77/M-82008	Podkładka sprężysta 12,2
22	14	PN-87/M-82302	Śruba z gniazdem sześciokątnym M8x20
23	6	PN-87/M-82302	Śruba z gniazdem sześciokątnym M8x40
24	6	PN-77/M-82008	Podkładka sprężysta 8,2
25	6	PN-86/M-82144	Nakrętka M8
26	2	PN-85/M-82105	Śruba z łbem sześciokątnym M12x30
27	2	PN-91/M-85001A	Wpust 10x8x25
28	4	PN-85/M-86100	Łożysko kulkowe 6207
29	2	PN-85/M-86100	Łożysko kulkowe 6210

**Spare parts and assembly - model R-120**

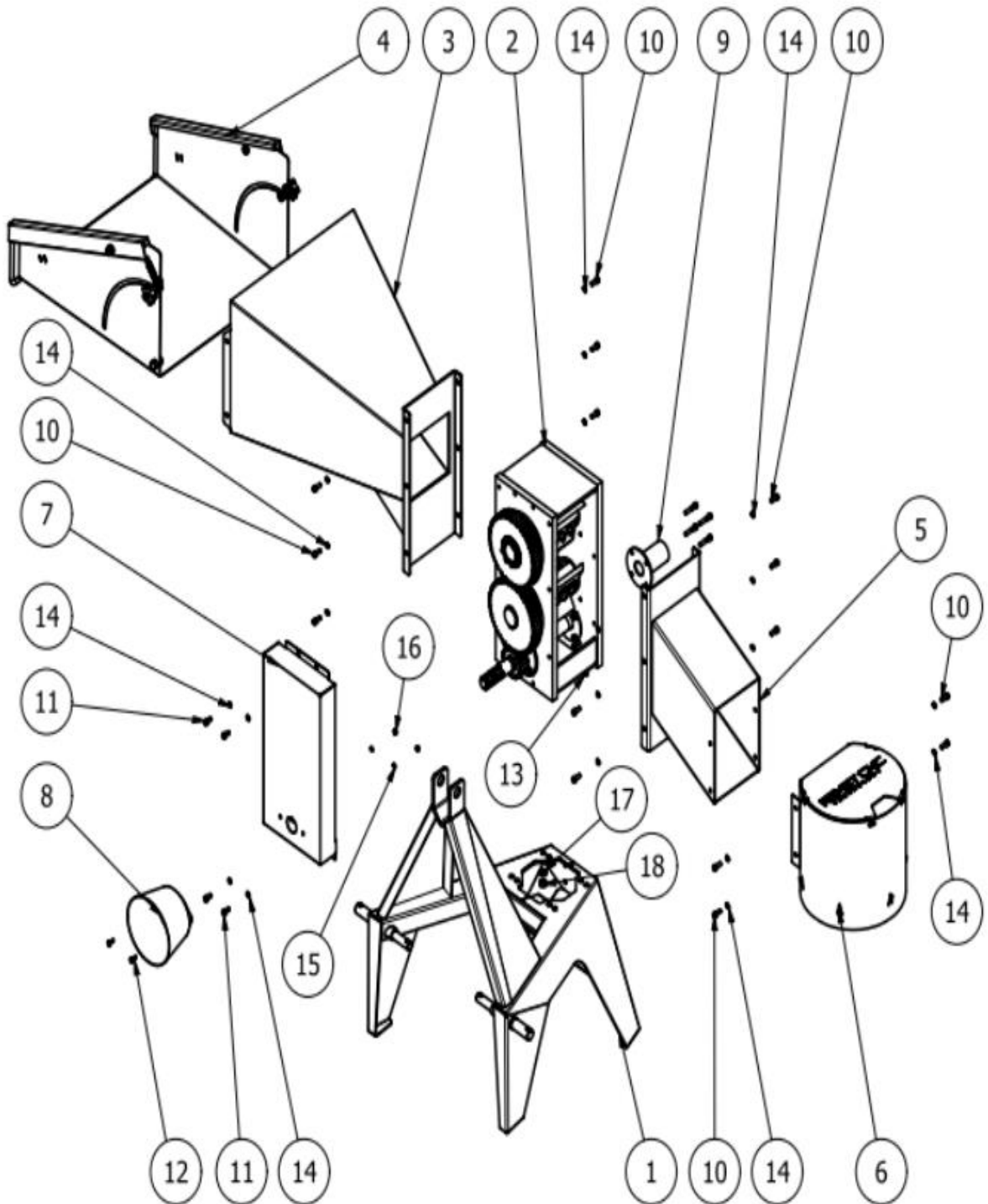



REMET CNC TECHNOLOGY SP. Z O.O.

LISTA CZĘŚCI			
Lp.	Ilość szt.	Numer części/norma	Nazwa
1	1	R120-00-00	Rama
2	1	R120-00-00	Mechanizm
3	1	R120-00-00	Wlot
4	1	R120-00-00	Dokładka
5	1	R120-00-00	Wylot
6	1	R120-00-00	Workownica R120
7	1	R120-01-00	Ośłona kół R120
8	1	R120-02-00	Oslona WOM-u
9	1	R120-03-00	Oslona wałka WOM
10	16	PN-87/M-82302	Śruba gniazdem sześciokątnym M8x20
11	4	PN-87/M-82302	Śruba gniazdem sześciokątnym M8x16
12	2	PN-85/M-82105	Śruba z łbem sześciokątnym M6x16
13	4	PN-85/M-82105	Śruba z łbem sześciokątnym M12x30
14	24	PN-77/M-82008	Podkładka sprężysta 8,2
15	2	PN-77/M-82008	Podkładka sprężysta 6,1
16	2	PN-86/M-82144	Nakrętka M6
17	4	PN-77/M-82008	Podkładka sprężysta 12,2
18	4	PN-86/M-82144	Nakrętka M12

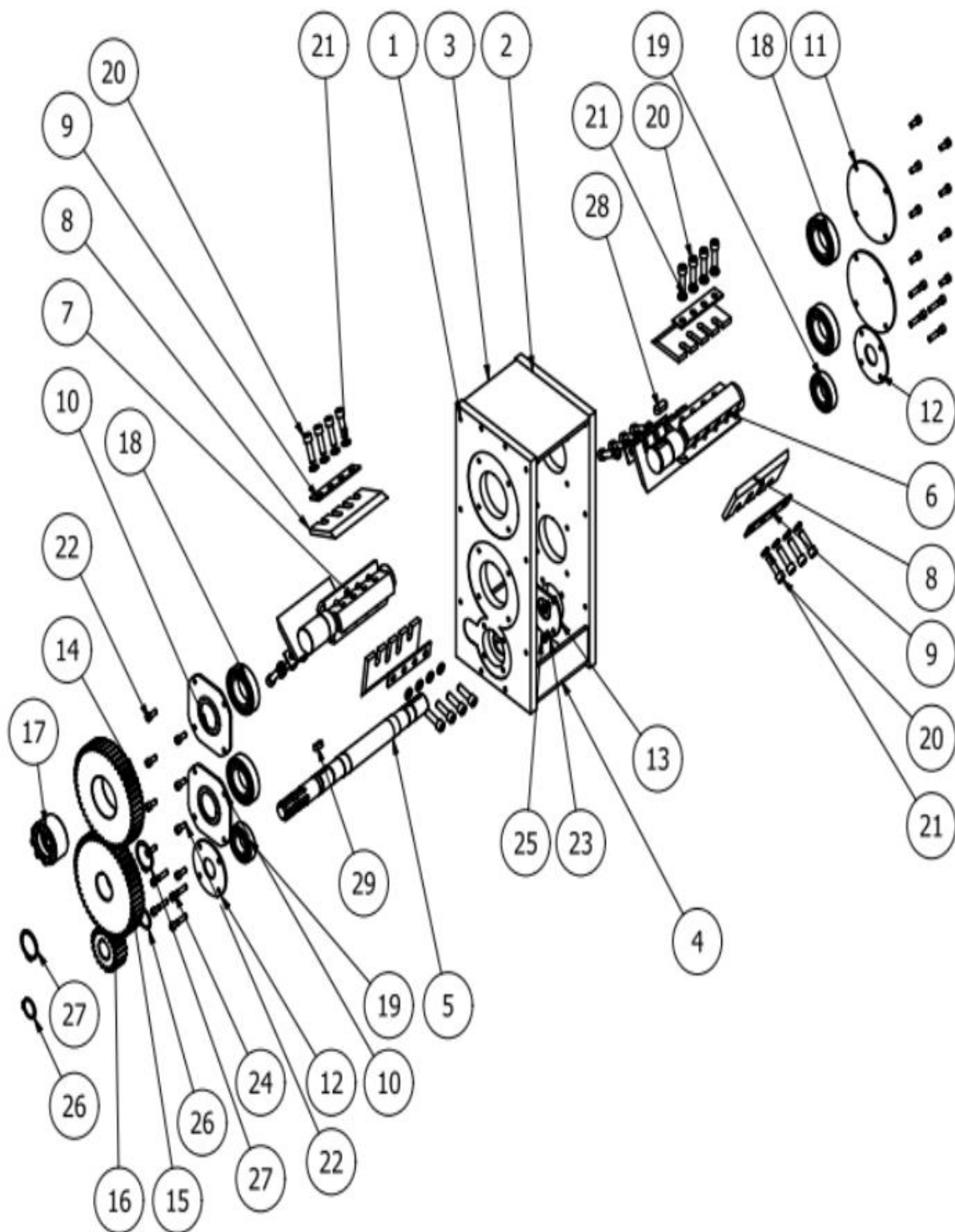

REMET CNC TECHNOLOGY SP. Z O.O.

LISTA CZĘŚCI			
Lp.	Ilość szt.	Numer części/norma	Nazwa
1	1	R120.010000-01	Blacha boczna 1
2	1	R120.010000-02	Blacha boczna 2
3	1	R120.010000-03	Blacha górna
4	2	R120.010000-04	Płaskownik mocujący
5	1	R120.010000-05	Wał napędowy R120
6	1	R120.010000-06	Wałek dolny
7	1	R120.010000-07	Wałek pod sprzęgło
8	6	R120.010000-08	Nóż R100
9	6	R120.010000-09	Podkładka pod nóż
10	2	R120.010000-10	Dekielek 1
11	2	R120.010000-11	Dekielek 2
12	2	R120.010000-12	Dekielek 3
13	2	R120.010000-13	Dekielek 4
14	1	R120.010000-14	Koło pod sprzęgło
15	1	R120.010000-15	Koło duże
16	1	R120.010000-16	Koło małe
17	1	R120.01010-001	Sprzęgło R120
18	4	PN-85/M-86100	Łożysko 6210
19	2	PN-85/M-86100	Łożysko 6207
20	24	PN-87/M-82302	Śruba z gniazdem sześciokątnym M12x40
21	24	PN-77/M-82008	Podkładka sprężysta 12,2
22	16	PN-87/M-82302	Śruba z gniazdem sześciokątnym M8x20
23	8	PN-77/M-82008	Podkładka sprężysta 8,2
24	8	PN-87/M-82302	Śruba z gniazdem sześciokątnym M8x40
25	8	PN-86/M-82144	Nakrętka M8
26	2	DIN 471	Pierścień sprężynujący 35x1,5
27	2	DIN 471	Pierścień sprężynujący 50x2
28	1	PN-91/M-85001A	Wpust 14x9x36
29	1	PN-91/M-85001A	Wpust 10x8x25

**Spare parts and assembly - model R-150**

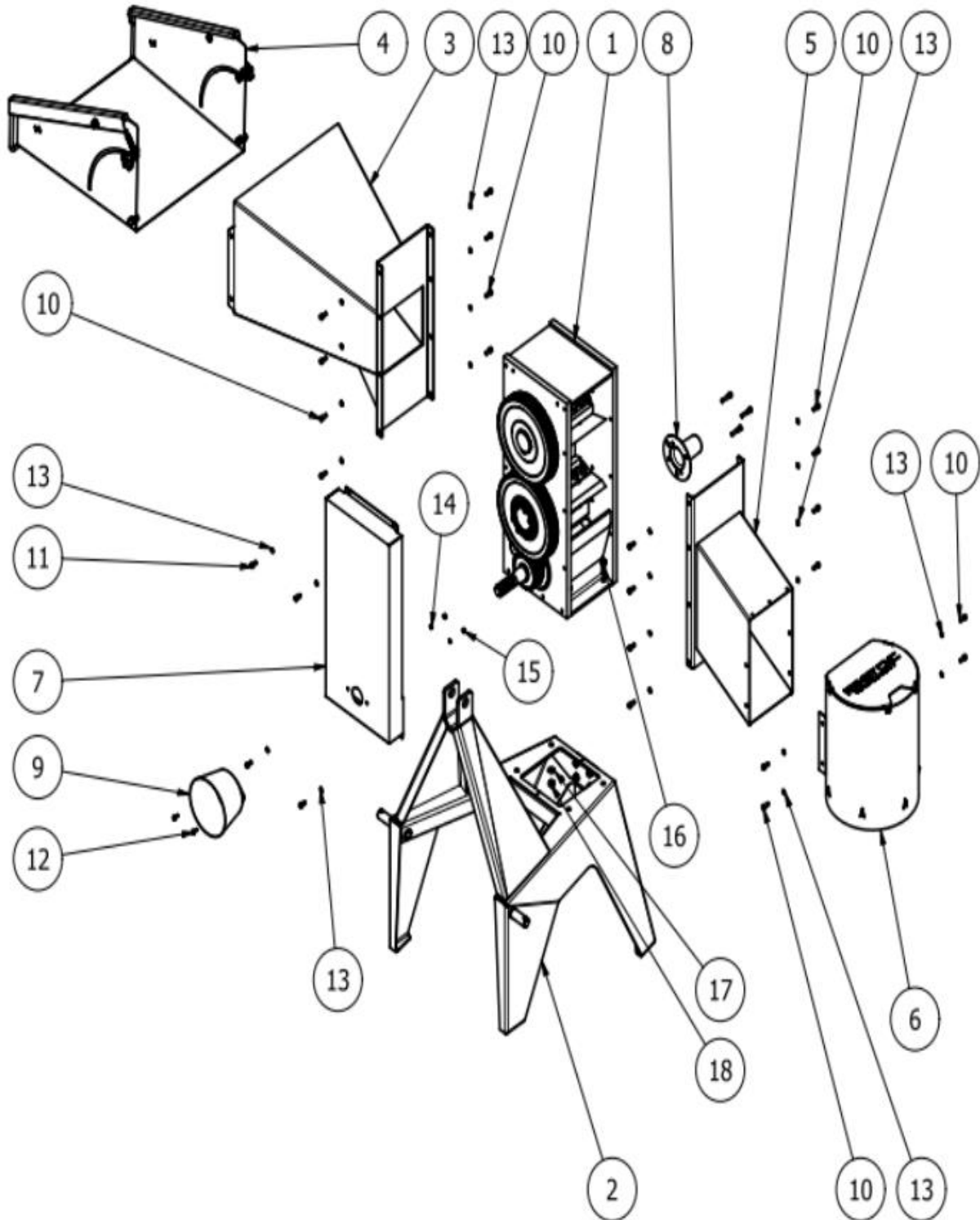

LISTA CZĘŚCI			
Lp.	Ilość szt.	Numer części/norma	Nazwa
1	1	R150-00-00	Mechanizm
2	1	R150-00-00	Rama R150
3	1	R150-00-00	Wlot
4	1	R150-00-00	Dokładka
5	1	R150-00-00	Wylot
6	1	R150-00-00	Workownica R150
7	1	R150-01-00	Ośłona kół
8	1	R150-02-00	Ośłona wałka WOM
9	1	R150-03-00	Oslona WOM-u
10	20	PN-87/M-82302	Śruba gniazdem sześciokątnym M8x20
11	4	PN-87/M-82302	Śruba gniazdem sześciokątnym M8x16
12	2	PN-85/M-82105	Śruba z łbem sześciokątnym M6x16
13	28	PN-77/M-82008	Podkładka sprężysta 8,2
14	2	PN-77/M-82008	Podkładka sprężysta 6,1
15	2	PN-77/M-82008	Nakrętka M6
16	4	PN-85/M-82105	Śruba z łbem sześciokątnym M12x30
17	4	PN-77/M-82008	Podkładka sprężysta 12,2
18	4	PN-77/M-82008	Nakrętka M12

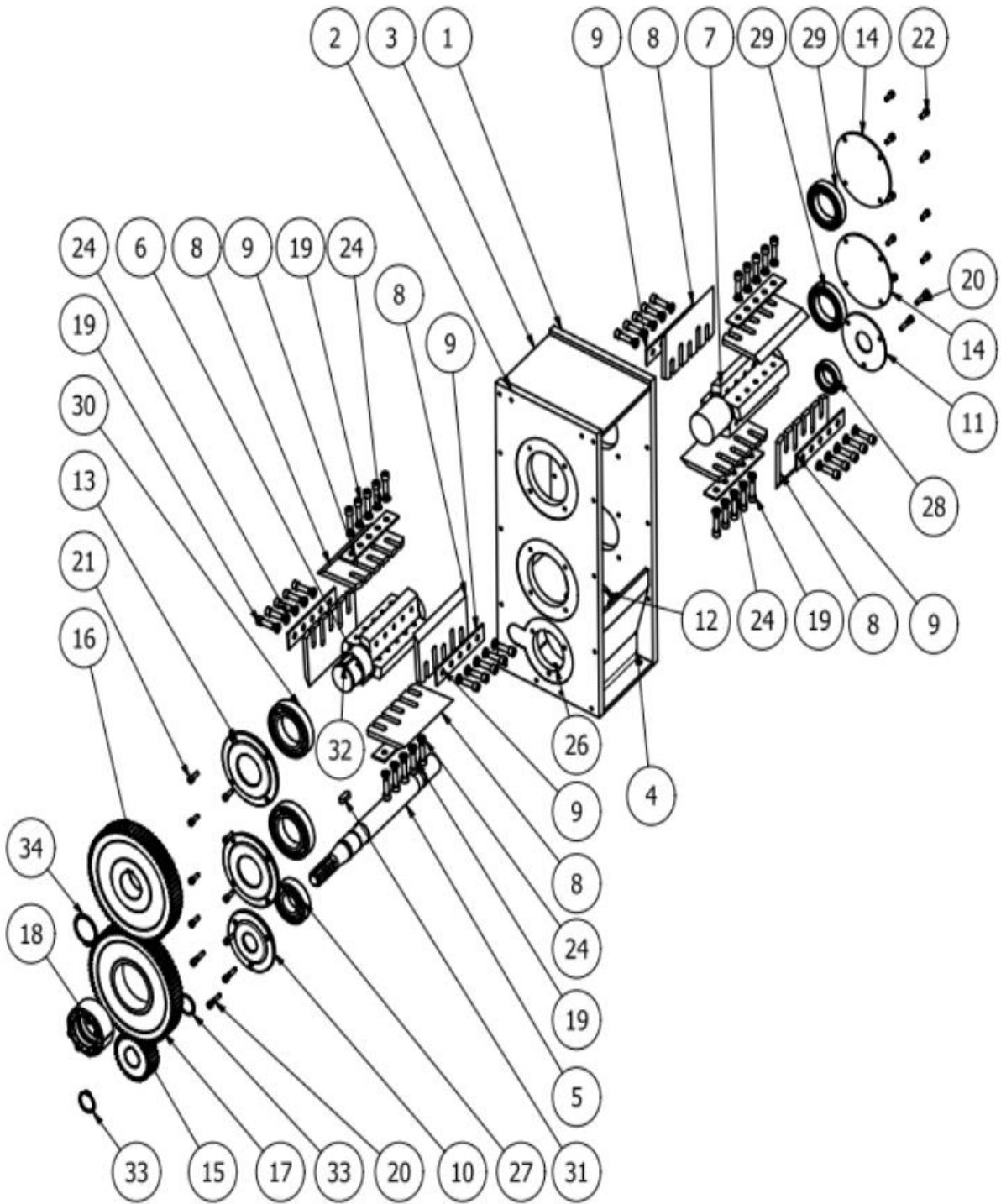

REMET CNC TECHNOLOGY SP. Z O.O.

LISTA CZĘŚCI			
Lp.	Ilość szt.	Numer części/norma	Nazwa
1	1	R150.010000-01	Blacha boczna 1
2	1	R150.010000-02	Blacha boczna 2
3	1	R150.010000-03	Blacha górna
4	2	R150.010000-04	Płaskownik mocujący
5	1	R150.010000-05	Wał napędowy
6	1	R150.010000-06.2	Walek tnacy 4N
7	1	R150.010000-07.2	Walek tnący pod sprzęgło 4N
8	8	R150.010000-08	Nóż R150
9	8	R150.010000-09	Podkładka na nóż
10	1	R150.010000-10	Dekielek 1
11	1	R150.010000-11	Dekielek 2
12	2	R150.010000-12	Dekielek 3
13	2	R150.010000-13	Dekielek 4
14	2	R150.010000-14	Dekielek 5
15	1	R150.010000-15	Koło zębate małe
16	1	R150.010000-16	Koło zębate duże
17	1	R150.010000-17	Koło zębate duże pod sprzęgło
18	1	R150.010100-01	Sprzęgło R150
19	40	PN-87/M-82302	Śruba z gniazdem sześciokątnym M12x40
20	6	PN-87/M-82302	Śruba z gniazdem sześciokątnym M8x40
21	8	PN-87/M-82302	Śruba z gniazdem sześciokątnym M8x25
22	8	PN-87/M-82302	Śruba z gniazdem sześciokątnym M8x20
23	8	PN-85/M-82105	Śruba z łbem sześciokątnym M10x45
24	40	PN-77/M-82008	Podkładka sprężysta 12,2
25	6	PN-77/M-82008	Podkładka sprężysta 8,2
26	6	PN-86/M-82144	Nakrętka M8
27	1	PN-85/M-86100	Łożysko 6309
28	1	PN-85/M-86100	Łożysko 6009
29	2	PN-85/M-86100	Łożysko 6014
30	2	PN-85/M-86100	Łożysko 6215
31	1	PN-91/M-85001A	Wpust 14x9x36
32	1	PN-91/M-85001A	Wpust 16x10x45
33	2	DIN 471	Pierścień sprężynujący 45x1,75
34	1	DIN 471	Pierścień sprężynujący 65x2,5

## 10. DISPOSAL AND ENVIRONMENT PROTECTION

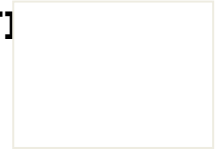
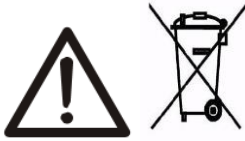

Dispose the device, accessories and packaging in accordance with environmental protection requirements at specialist disposal points.

The device must not be disposed of with household waste. Protect the environment. The device should be returned to a local recycling point. Disposal is free. You can get more information at the disposal point. Incorrect disposal may be punished in accordance with local regulations.

## 11. SOLUTIONS FOR EXAMPLE PROBLEMS

Problem	Possible cause	Solution
The device does not draw branches	The cutting roller is blocked	Disconnect the drive, remove the locking element, if possible
	The cutting rollers rotate "backwards"	The drive shaft rotates counter-clockwise (counterclockwise) to the right
Branches are not truncated correctly	The cutting knives are not correctly set, the clearance between the blades is greater than 0.2 mm	Observe the condition of the knives while observing the safety requirements and adjust the clearance if necessary (see step 8)
	The cutting rollers are moved, the cutting knives do not converge, one ahead of the other	Necessary alignment of the cutting rollers in the axis, see item 10
Metallic or other disturbing sounds are heard during work	Too much contamination inside the mechanism or possible damage to the rolling bearing	After disconnecting the drive source, clean the inside of the mechanism. If the bearing is damaged, it must be replaced by qualified personnel



## 12. GUARANTEE CARD (based on proof of purchase)

<b>Device symbol:</b> .....	
<b>Serial number:</b> .....	
<b>Date of production:</b> 201....	
<b>Sale date:</b> .....	
<b>Signature of the seller:</b> .....	_____
	Rubber stamp

### **PRINCIPLES OF THE WARRANTY GUARANTEE:**

1. This device is provided with a 24-month limited warranty.
2. In the case of use in companies, commercial use and any other than private use, the warranty period is shortened (12 month).
3. Damage caused by natural wear, overload or improper handling is excluded from the warranty. Parts subject to natural wear are not covered by the warranty.
4. Observe work instructions, tractor aggregation, inspection, cleaning, maintenance, storage and transport for warranty service.
5. Damage caused by defects in material or workmanship will be removed free of charge by delivery of new equipment or repair. The condition for using the warranty service is to provide the complete unit with the purchase document to the service center at the company's premises.
6. For warranty repairs are not eligible repair caused by:
  - use of the chopper contrary to the instruction manual and intended use,
  - Random events or others for which the guarantor is not responsible
  - When connecting the tractor to the tractor with a PTO shaft equipped with an overload clutch
7. The Guarantor may not accept the warranty if found:
  - make modifications,
  - Introduction of structural changes,
  - In case of not using the overload coupling on the PTO shaft
  - Damage caused by random events,
  - The lack of required information and records or their modifications in the warranty card,
  - Use the chopper contrary to the instruction manual and destination.
8. Repairs not covered by the warranty can be ordered for payment to our service center. Only equipment that has been delivered in the right packaging will be repaired and transport costs will be paid.
9. If you have notified warranty repairs, please contact us
10. With the service desk. You can get further information about the complaint there.
11. Disposal of the unit is carried out free of charge.

## DECLARATION OF CONFORMITY CE

The last two digits of the year of affixing the CE marking – 18

the number of the declaration: 01/R/2018

1. Device name:

type: Chipper (for PTO drive)  
 name: Red Dragon STANDARD  
 model: R-60, R-80, R-100, R-120, R-150

2. Manufacturer:

REMET CNC TECHNOLOGY Sp. z o.o  
 Łowisko 320A, 36-053 Kamień, POLSKA

3. This declaration of conformity is issued under the sole responsibility of the manufacturer.

4. The object of the declaration is a machine for cutting branches and wooden waste

4. The object of the declaration is a machine for cutting branches and wooden waste

2006/42/WE DIRECTIVE 2006/42/CE OF THE EUROPEAN PARLIAMENT AND OF THE COUNCIL of 17 May 2006 on machinery, amending Directive 95/16/UE  
 2014/30/UE DIRECTIVE OF THE EUROPEAN PARLIAMENT AND OF THE COUNCIL 2014/30 / EU of 26 February 2014 on the harmonization of the laws of the Member States relating to electromagnetic compatibility, replaces Directive 2004/108/WE

6. References to referenced harmonized standards and national standards (or parts thereof) which have been applied for which compliance is declared:

EN 349:1993+A1:2008	Safety of machinery. Minimum gaps to avoid crushing of parts of the human body
PN-EN 349+A1:2008	Safety of machinery. Minimum gaps to avoid crushing of parts of the human body
EN 953:1997+A1:2009	Safety of machinery. Guards. General requirements for the design and construction of fixed and movable guards
PN-EN 953+A1:2009	Safety of machinery. Guards. General requirements for the design and construction of fixed and movable guards
EN 614-1:2006+A1:2009	Safety of machinery. Ergonomic design principles. Part 1: Terminology and general principles
PN-EN 614+A1:2009	Safety of machinery. Ergonomic design principles. Part 1: Terminology and general principles
EN 614-2:2000+A1:2008	Ergonomic design principles. Part 2: Interactions between the design of machinery and work tasks
PN-EN 614-2+A1:2010	Ergonomic design principles. Part 2: Interactions between the design of machinery and work tasks
EN 13525+A2:2009	Forestry machines - Wood chipper - Safety
EN 13525:2005+A2:2009	Forestry machines - Wood chipper - Safety
PN-EN 13525+A1:2007	Forestry machines - Wood chipper - Safety
EN60204-1:2006+A1:2009+AC:2010	Safety of machinery. Electrical equipment of machines. General requirements
PN-EN 60204-1:2010	Safety of machinery. Electrical equipment of machines. General requirements
EN 60529:1991+A1:2009+AC:2010	Degrees of protection provided by enclosures (IP code)
PN-EN 60529:2003	Degrees of protection provided by enclosures (IP code)
EN ISO 12100:2010	Safety of machinery - General principles of design - Risk assessment and risk reduction
PN-EN ISO 12100:2010	Safety of machinery - General principles of design - Risk assessment and risk reduction
EN 60529:1991+A1:2009+AC:2010	Safety of machinery - General principles of design - Risk assessment and risk reduction
PN-EN ISO 14120:2016-03	Machine safety - Guards - General requirements for the design and construction of fixed and movable guards
EN ISO 14120:20156	Machine safety - Guards - General requirements for the design and construction of fixed and movable guards

7. Person authorized to prepare and store technical documentation

Łukasz Kolano  
 REMET CNC TECHNOLOGY Sp. z o.o.  
 Łowisko 320A, 36-053 Kamień, POLSKA

8. This declaration of conformity is the basis for marking the product with a mark **CE**.

Declaration Issued based on the conformity assessment process carried out. This declaration applies only to the machine in the state in which it was placed on the market and does not cover components added by the end-user or subsequent changes..

On behalf of the manufacturer, signed:  
 Łowisko, 14 June 2018  
 (place and date of issue)

  
**Piekut Marek**  
 \_\_\_\_\_  
 VICE PRESIDENT  
 (signature)

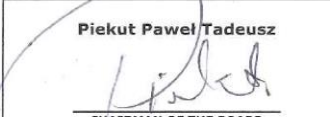
  
**Piekut Pawel Tadeusz**  
 \_\_\_\_\_  
 CHAIRMAN OF THE BOARD  
 (signature)

REMET CNC TECHNOLOGY  
 Sp. z o.o  
 Łowisko 320A, 36-053  
 Kamień, POLSKA

**REMET CNC**  
 TECHNOLOGY

tel. +48 17 583 63 87  
 info@remetcnc.com  
 www.remetcnc.com