

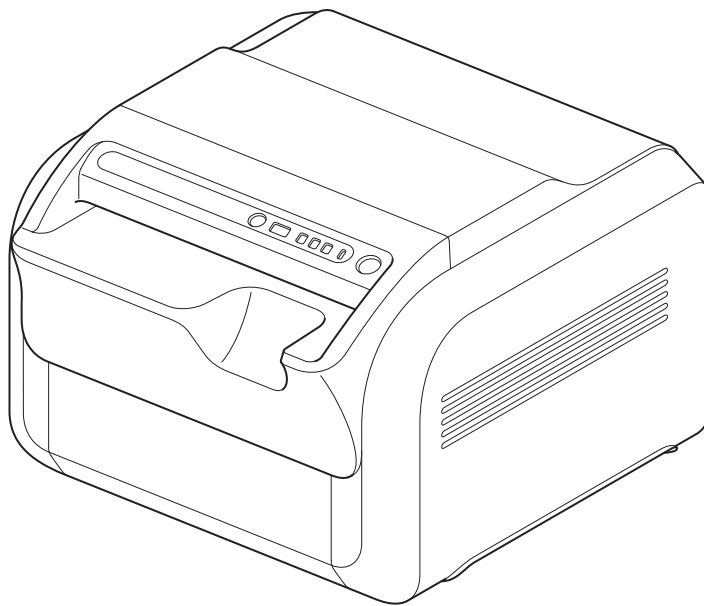

(CR-IR 392)

Operation Manual

11th Edition December 2021



For Safe Operation

Product Overview

Basic Operation

**Care and
Maintenance**

Appendix

**Maintenance and
Inspection**

This Operation Manual describes details on how to operate the FCR PRIMA T2 (CR-IR 392) and cautions to be observed when operating it. Please read the Operation Manual thoroughly before actually operating the FCR PRIMA T2 (CR-IR 392) system. After reading this manual, store it nearby the FCR PRIMA T2 (CR-IR 392) so that you can see it whenever necessary.

Introduction

The FCR PRIMA T2 (CR-IR 392) Operation Manual (hereafter referred to as this manual) provides information necessary for the use of the FCR PRIMA T2 (CR-IR 392), including an overview of the FCR PRIMA T2 (CR-IR 392), operation instructions and operation precautions, daily checks and maintenance, and so on.

Accompanying documents were originally drafted in the English language.

Installation may only be conducted by authorized service personal.

This Operation Manual is applicable to the following software.

- FCR PRIMA T2 main unit software V2.0 or later

Indications for use (for U.S.)

The indications for use of the FCR PRIMA T2 (CR-IR 392) Image Reader with Imaging Plate (IP) reading is the identification, capture, digitization, and processing of diagnostic X-ray images of human anatomy, and associating patient and exam identification with the images.

Intended use (for European Union and other countries.)

The FCR PRIMA T2 (CR-IR 392) is equipment designed to scan an X-ray image formed on an imaging plate (IP), being an image reading unit used for the CR-IR 392 Fuji Computed Radiography system.

An IP is used as an X-ray image detector. It records the image information of an image captured by an X-ray exposure.

Note : The above statements were determined by applicable medical device regulations which vary throughout the world. These statements are subject to revision when additional clearance or approval is obtained.

CAUTION

- 1 No part or all of this manual may be reproduced in any form without prior permission.
- 2 The information contained in this manual may be subject to change without prior notice.
- 3 FUJIFILM Corporation shall not be liable for malfunctions and damages resulting from installation, relocation, remodeling, maintenance, and repair performed by other than dealers specified by FUJIFILM Corporation.
- 4 FUJIFILM Corporation shall not be liable for malfunctions and damages of FUJIFILM Corporation products due to products of other manufacturers not supplied by FUJIFILM Corporation.
- 5 FUJIFILM Corporation shall not be liable for malfunctions and damages resulting from remodeling, maintenance, and repair using repair parts other than those specified by FUJIFILM Corporation.
- 6 FUJIFILM Corporation shall not be liable for malfunctions and damages resulting from negligence of precautions and operating methods contained in this manual.
- 7 FUJIFILM Corporation shall not be liable for malfunctions and damages resulting from use under environment conditions outside the range of using conditions for this product such as power supply, installation environment, etc. contained in this manual.
- 8 FUJIFILM Corporation shall not be liable for malfunctions and damages resulting from natural disasters such as fires, earthquakes, floods, lightning, etc.

Caution: Rx Only in the United States (Federal law restricts this device to sale by or on the order of a physician).

Open-Source Software Used in This Product

This product uses third party's software that is made available as open source software or free software.

SUCH SOFTWARE IS PROVIDED "AS IS" WITH NO WARRANTY OF ANY KIND AS TO ITS MERCHANTABILITY OR FITNESS FOR ANY PARTICULAR PURPOSE.

For information on open source software used in this product, please see the attached CD.

Source codes for certain type of open source software used in this product are available at delivery cost. If you would like to receive such source codes, please contact FUJIFILM dealer or the service representatives at the agency from which you purchased this product.

(Please be noted that any inquiries concerning the contents of source codes should be directed to original licensors of open source software.)

How to Read This Manual

Marks

Information items to be observed when you are operating this system and the supplementary remarks are described in this manual with the respective marks.

For the safe system operation, be sure to observe Warning/Caution.



Indicates hazardous situations that may lead to serious injury or even death if the precaution is not or could not be followed.



Indicates hazardous situations that may lead to mild or moderate injury or physical damages if the caution is not or cannot be followed.



Shows an item helpful for further effective system operation.



Shows a more detailed operation method or an item that describes additional information.

Trademark

FCR is a trademark or a registered trademark of FUJIFILM Corporation.

Copyright © 2012-2021 FUJIFILM Corporation. All rights reserved.

Contents

Introduction.....	iii
How to Read This Manual	iv

Chapter 1 For Safe Operation

1.1	Precautions Before Operating This Equipment	1-1
1.2	Precautions to be Observed When Using the Electric Medical Equipment.....	1-2
1.3	Safety	1-3
1.4	Electromagnetic Compatibility (EMC).....	1-5
1.5	Precautions to Take When Using the FCR PRIMA T2 (CR-IR 392).....	1-11
1.6	Location of Each Label and Mark.....	1-12
1.6.1	Locations	1-12
1.6.2	Safety and Other Signs	1-13

Chapter 2 Product Overview

2.1	Features of the FCR PRIMA T2 (CR-IR 392)	2-1
2.2	Units Names and the Functions	2-2
2.2.1	FCR PRIMA T2 (CR-IR 392) Main Unit	2-2
2.2.2	Operation Panel.....	2-3
2.2.3	Operation Panel Display at the Time of Startup/Shutdown.....	2-4

Chapter 3 Basic Operation

3.1	Performing Erasure Before Use IPs	3-1
3.2	System Startup/Shutdown and Image Reading (Console)	3-2
3.2.1	Starting Up the System	3-2
3.2.2	Shutting Down the System	3-3
3.2.3	Reading Cassette IP Images.....	3-4
3.3	Starting Up/Shutting Down the FCR PRIMA T2 Main Unit.....	3-5

Chapter 4 Care and Maintenance

4.1	About Performing Daily Checks and Maintenance.....	4-1
4.2	Cleaning the Cassette Set Unit	4-1
4.3	Users Check Sheet	4-2
4.4	About Preventive Maintenance.....	4-3

Appendix A Specifications

A.1	Specifications	A-1
A.1.1	Details of Equipment Specifications	A-1

Maintenance and Inspection

Chapter 1 For Safe Operation

1.1 Precautions Before Operating This Equipment

Before using this equipment, please read this page carefully so that you can operate it correctly. Whenever you operate this equipment, be sure to observe those precautions. Failure to do so may cause you to subject to injuries or property damage to occur.

This system is classified as a medical device under EC Directive 93/42/EEC.
This equipment has been designed on the assumption that the patient would not come into direct contact with it or for operation by appropriately trained operator.

Process waste correctly, as stipulated by local law or any regulations that apply.

1.2 Precautions to be Observed When Using the Electric Medical Equipment

We ask that you observe these usage precautions and use the equipment correctly.

1. This equipment should be used only by people who have the proper skills.
2. Observe the following precautions when installing the equipment.
 - 2-1. Install the equipment where water will not splash it.
 - 2-2. Install the equipment where it will not be adversely affected by air pressure, temperature, humidity, ventilation, sunlight, dust or the presence of salt, sulfur or like substances in the atmosphere.
 - 2-3. Make sure the equipment will remain in stable condition on a level surface and not be subjected to vibration or shock.
 - 2-4. Do not install the equipment in places where chemicals are stored or gases emitted.
 - 2-5. Make sure that the power frequency, voltage and power consumption are appropriate.
 - 2-6. Connect the ground wire correctly.
3. Observe the following precautions before beginning to use the device.
 - 3-1. Inspect the switch contacts, polarities, dial settings and meters and confirm that the equipment is functioning properly.
 - 3-2. Confirm that the ground wire has been completely connected.
 - 3-3. Make sure that all cords have been connected properly and safely.
 - 3-4. Be aware that correct diagnosis can be hindered and danger can result from using different pieces of equipment together.
4. Observe the following precautions after using the equipment.
 - 4-1. Using the established procedure, restore the operation switches, dials, etc., to what they were prior to use and then turn the power off.
 - 4-2. When unplugging cords, do not pull on the body of the cord itself or apply unnecessary force.
 - 4-3. After using the accessories, recollect them and put them back in order.
5. If there is trouble with the equipment, do not attempt to fix it randomly. Instead, do what is indicated and entrust repairs to a professional.
6. Do not remodel the equipment.
7. Maintenance and Inspection
 - 7-1. Make inspect the equipment and parts periodically.
 - 7-2. If the equipment has not been used for a long time, make sure that it operates normally and safely prior to using it again.
8. Other Items
 - 8-1. When subjecting patients (particularly infants and pregnant women) to radiation, make sure not to exceed the necessary time and dose. Also, ensure that radiation is contained within the region for exposure.
 - 8-2. Follow the Operation Manual and operate the equipment correctly.

1.3 Safety

Prior to using this equipment, please carefully read safety precautions presented herein for you to operate it correctly.

Laser Handling Precautions

This equipment is a Class 1 laser product (IEC 60825-1:2014/EN 60825-1:2014).

FCR PRIMA T2 (CR-IR 392) Laser Unit Specifications

Class	: 3B
Medium	: Semiconductor laser
Wavelength	: 659 nm
Maximum output	: 68.2 mW (CW)
Maximum output under Fault condition	: 130 mW (CW)
Beam divergence (parallel)	: 7°~12°
(perpendicular)	: 14°~20°

WARNING

The FCR PRIMA T2 (CR-IR 392) incorporates a Class 3B laser with maximum output of 68.2 mW. To prevent exposure to its laser beams, observe the following precautions.

- Never open or remove the protective covers.
- Always contact a qualified service engineer immediately if you suspect there is a malfunction.

CAUTION

Use of controls or adjustments or performance of procedures other than those specified herein may result in hazardous radiation exposure.

Authorized Safety Standards

UL 60601-1 (UL approved)

EN 60601-1

ANSI/AAMI ES 60601-1

Note, however, that UL certification does not take effect if this equipment is used mounted on board a vehicle because it has not been applied for appropriate approval from UL-PS.

Classification

- 1) According to the type of protection against electrical shock
CLASS 1 EQUIPMENT
- 2) According to the degree of protection against electric shock
NO APPLIED PART
- 3) Protection against harmful ingress of water
IPX0
- 4) According to the degree of safety of application in the presence of a flammable anesthetics mixture with air or with oxygen or nitrous oxide.
Equipment not suitable for use in the presence of a flammable anesthetics mixture with air or with oxygen or nitrous oxide.
- 5) According to the mode of operation
CONTINUOUS OPERATION

General Precautions Against Electrical Shock

WARNING

The service voltage of this equipment is 100 to 240 VAC.

Instructions below must be followed to prevent an electrical shock to users.

- Never open equipment covers. Do not touch high-voltage units of the equipment with your hand, otherwise you may receive an electrical shock.
- Install the equipment where no water may subject the equipment.
- Ensure that the equipment is properly grounded.
- Check that all the cables are properly and perfectly connected.
- When using the equipment within the environment where the patient may get into touch with it, optionally connect additional protective earth conductor (FCR PRIMA T2 (CR-IR 392)).
- When using the equipment within the environment where the patient may get into touch with it, the user must not touch the equipment's exterior, such as covers and metal sections, and the patient at the same time.

1.4 Electromagnetic Compatibility (EMC)

Electromagnetic Compatibility (EMC) Standards

This system has been tested and found to comply with the limits for medical devices to the IEC 60601-1-2 (EN 60601-1-2), Medical Device Directive 93/42/EEC.

These limits are designed to provide reasonable protection against harmful interference in a typical medical installation, as this equipment is suitable for use in a professional healthcare facility environment and in a home healthcare environment.

These limits are designed to provide reasonable protection against harmful interference in a typical medical installation.

Each device generates, uses and can radiate radio frequency energy and, if not installed and used in accordance with the instructions, may cause harmful interference to each device or other devices in the vicinity.

However, there is no guarantee that interference will not occur in a particular installation.

If each device does cause harmful interference to other devices, which can be determined by tuning the equipment off and on, the user is encouraged to try to correct the interference by one or more of the following measures:

- Reorient or relocate the receiving device.
- Increase the separation between the devices.
- Connect the equipment into an outlet on a circuit different from that to which the other device(s) are connected.

If the problem cannot be solved with the above measures, stop using this equipment and consult the manufacturer, our official dealer or FUJIFILM Representative for help.



WARNING

- **Do not place devices generating electromagnetic wave near this equipment.**
- **If a device(s) other than those specified is connected, predetermined EMC performance cannot be guaranteed.**
- **Do not use mobile RF communications equipment within 30cm (11.8 in.) of this equipment.**
- **The product may be interfered with by other equipment, even if that other equipment complies with CISPR EMISSION requirements.**
- **Do not use this equipment near devices that generate strong electromagnetic waves, such as thermotherapy devices or HF surgical equipment.**
- **If this equipment is used near commercially available electronic devices, such as mobile phones, laptop computers or home appliances, which generate electromagnetic waves, this equipment may malfunction due to electromagnetic interference.**
- **The emissions characteristics of this equipment make it suitable for use in industrial areas and residential environments and hospitals (CISPR 11 class B). If it is used in a residential environment, this equipment might not offer adequate protection to radio-frequency communication services. The user might need to take mitigation measures, such as relocating or re-orienting the equipment.**
- **Do not use this equipment near X-ray units other than the designated mobile X-ray units or near large medical devices, such as MRI scanners or X-ray CT scanners.**

Further Information for IEC 60601-1-2 (EN 60601-1-2)

1. The CR-IR 392 complies with IEC 60601-1-2:2014 (EN 60601-1-2:2015).
2. Medical electrical equipment needs special precautions regarding EMC and needs to be installed and put into service according to the EMC information provided in Tables 1 to 5.
3. Portable and mobile RF communications equipment and other devices, which cause electromagnetic interference, can affect medical electrical equipment, resulting in image data communication failure or artifacts.
4. Information regarding the cable affecting EMC is as follows.

Cable	Maximum Length	Specification
Power Cable	3.0m (9.8 ft)	Non-shielded

5. The use of optional items, transducers and cables other than those specified, with the exception of transducers and cables sold by FUJIFILM Corporation as replacement parts for internal components, may result in increased emissions or decreased immunity of the CR-IR 392.
6. The equipment should not be used adjacent to or stacked with other equipment.
If adjacent or stacked use is necessary, the equipment should be observed to verify normal operation in the configuration in which it will be used.
7. Test items (Tables 1 to 5)

Table 1

Guidance and manufacturer's declaration - electromagnetic emissions		
The CR-IR 392 is intended for use in the electromagnetic environment specified below. The customer or the user of the CR-IR 392 should assure that it is used in such an environment.		
Emissions test	Compliance	Electromagnetic environment - guidance
RF emissions CISPR 11	Group 1	The CR-IR 392 uses RF energy only for their internal function. Therefore, their RF emissions are very low and are not likely to cause any interference in nearby electronic equipment.
RF emissions CISPR 11	Class B	The CR-IR 392 is suitable for use in all establishments, including domestic establishments and those directly connected to the public low-voltage power supply network that supplies buildings used for domestic purposes.
Harmonic emissions IEC 61000-3-2	Complies	
Voltage fluctuations/ flicker emissions IEC 61000-3-3	Complies	

Note : Harmonic emission IEC 61000-3-2 and voltage fluctuation/flicker emission IEC 61000-3-3 are applicable only to the devices with a rated voltage of AC220V or higher.

Table 2

Guidance and manufacturer's declaration - electromagnetic immunity			
The CR-IR 392 is intended for use in the electromagnetic environment specified below. The customer or the user of the CR-IR 392 should assure that it is used in such an environment.			
Immunity test	IEC 60601-1-2 test level	Compliance level	Electromagnetic environment - guidance
Electrostatic discharge (ESD) IEC61000-4-2	±8kV contact ±15kV air	±8kV contact ±15kV air	Floors should be wood, concrete or ceramic tile. If floors are covered with synthetic material, the relative humidity should be at least 30%.
Electrical fast transient/burst IEC61000-4-4	±2kV for power supply lines ±1kV for input/output lines	±2kV for power supply lines ±1kV for input/output lines	Mains power quality should be that of a typical commercial or hospital environment.
Surge IEC61000-4-5	±1kV line(s) to line(s) ±2kV line(s) to earth	±1kV line(s) to line(s) ±2kV line(s) to earth	Mains power quality should be that of a typical commercial or hospital environment.
Voltage dips, short interruptions and voltage variations on power supply input lines IEC61000-4-11	0% U_T for 0.5 cycle and 1 cycle 70% U_T (30% dip in U_T) for 25 cycles 0% U_T for 5 s	0% U_T for 0.5 cycle and 1 cycle 70% U_T (30% dip in U_T) for 25 cycles 0% U_T for 5 s	Mains power quality should be that of a typical commercial or hospital environment. If the user of the CR-IR 392 requires continued operation during power mains interruptions, it is recommended that the CR-IR 392 be powered from an uninterruptible power supply or a battery.
Power frequency (50/60Hz) magnetic field IEC61000-4-8	30 A/m	30 A/m	Power frequency magnetic fields should be at levels characteristic of a typical location in a typical commercial or hospital environment.
NOTE: U_T is the a.c. mains voltage prior to application of the test level.			

Table 3

Guidance and manufacturer's declaration - electromagnetic immunity									
The CR-IR 392 is intended for use in the electromagnetic environment specified below. The customer or the user of the CR-IR 392 should assure that it is used in such an environment.									
Immunity test	IEC 60601-1-2 test level	Compliance level	Electromagnetic environment - guidance						
Conducted RF IEC61000-4-6	3 V 150 kHz to 80 MHz ISM Frequency band Amateur radio band	3 V * See Table 5.	Portable and mobile RF communications equipment should be used no closer to any part of the CR-IR 392, including cables, than the recommended separation distance calculated from the equation applicable to the frequency of the transmitter.						
Radiated RF IEC61000-4-3	10 V/m 80 MHz to 2.7 GHz Proximity fields from RF	10 V/m * See Table 5.	<p>Recommended separation distance</p> <table style="margin-left: 20px;"> <tr> <td>$d = 1.2\sqrt{P}$</td> <td>150 kHz to 80 MHz</td> </tr> <tr> <td>$d = 1.2\sqrt{P}$</td> <td>80 MHz to 800 MHz</td> </tr> <tr> <td>$d = 2.3\sqrt{P}$</td> <td>800 MHz to 2.7 GHz</td> </tr> </table> <p>where P is the maximum output power rating of the transmitter in watts (W) according to the transmitter manufacturer and d is the recommended separation distance in metres (m). Field strengths from fixed RF transmitters, as determined by an electromagnetic site survey,^a should be less than the compliance level in each frequency range.^b Interference may occur in the vicinity of equipment marked with the following symbol:</p> <div style="text-align: center;">  </div>	$d = 1.2\sqrt{P}$	150 kHz to 80 MHz	$d = 1.2\sqrt{P}$	80 MHz to 800 MHz	$d = 2.3\sqrt{P}$	800 MHz to 2.7 GHz
$d = 1.2\sqrt{P}$	150 kHz to 80 MHz								
$d = 1.2\sqrt{P}$	80 MHz to 800 MHz								
$d = 2.3\sqrt{P}$	800 MHz to 2.7 GHz								
NOTE 1: At 80 MHz and 800 MHz, the separation distance for the higher frequency range applies.									
NOTE 2: These guidelines may not apply in all situations. Electromagnetic propagation is affected by absorption and reflection from structures, objects and people.									
<p>a Field strength from fixed transmitters, such as base stations for radio (cellular/cordless) telephones and land mobile radios, amateur radio, AM and FM radio broadcast and TV broadcast cannot be predicted theoretically with accuracy. To assess the electromagnetic environment due to fixed RF transmitters, an electromagnetic site survey should be considered. If the measured field strength in the location in which the CR-IR 392 is used exceeds the applicable RF compliance, the CR-IR 392 should be observed to verify normal operation. If abnormal performance is observed, additional measures may be necessary, such as reorienting or relocating the CR-IR 392.</p> <p>b Over the frequency range 150 kHz to 80 MHz, field strength should be less than 3 V/m.</p>									

Table 4

Recommended separation distances between Portable and mobile RF communications equipment and the CR-IR 392			
<p>The CR-IR 392 is intended for use in the electromagnetic environment in which radiated RF disturbances are controlled.</p> <p>The customer or the user of the CR-IR 392 can help prevent electromagnetic interference by maintaining a minimum distance between portable and mobile RF communications equipment (transmitters) and the CR-IR 392 as recommended below, according to the maximum output power of the communications equipment.</p>			
Rated maximum output power of transmitter W	Separation distance according to frequency of transmitter m		
	150 kHz to 80 MHz $d = 1.2\sqrt{P}$	80 MHz to 800 MHz $d = 1.2\sqrt{P}$	800 MHz to 2.7 GHz $d = 2.3\sqrt{P}$
0.01	0.12	0.12	0.23
0.1	0.38	0.38	0.73
1	1.2	1.2	2.3
10	3.8	3.8	7.3
100	12	12	23
<p>For transmitters rated at a maximum output power not listed above, the recommended separation distance d in metres (m) can be estimated using the equation applicable to the frequency of the transmitter, where P is the maximum output power rating of the transmitter in watts (W) according to the transmitter manufacturer.</p>			
<p>NOTE 1: At 80 MHz and 800 MHz, the separation distance for the higher frequency range applies.</p> <p>NOTE 2: These guidelines may not apply in all situations. Electromagnetic propagation is affected by absorption and reflection from structures, objects and people.</p>			

Table 5

Test compliance levels between portable and mobile RF communications equipment and the CR-IR 392			
ISM (Industrial, Scientific and Medical) frequency band compliance level			
Frequency MHz	Test level V	Frequency MHz	Test level V
6.765	6	13.553	6
26.957	6	40.66	6
Amateur radio band compliance level			
Frequency MHz	Test Level V	Frequency MHz	Test Level V
1.8	6	3.5	6
5.3	6	7	6
10.1	6	14	6
18.07	6	21	6
24.89	6	28	6
50	6		
Proximity fields from RF compliance level			
Frequency MHz	Test level V/m	Frequency MHz	Test level V/m
385	27	450	28
710	9	745	9
780	9	810	28
870	28	930	28
1462	10	1720	28
1845	28	1970	28
2450	28	3540	10
5240	9	5500	9
5785	9		

1.5 Precautions to Take When Using the FCR PRIMA T2 (CR-IR 392)

1. Do not apply excessive force to a cassette when it is being inserted and also while it sits inside. Otherwise, personal injury and/or damage to the FCR PRIMA T2 (CR-IR 392) may result.
2. When a long-view cassette is used, secure the FCR PRIMA T2 (CR-IR 392) main unit, and use a board to support the weight of the cassette. If excessive force is applied to the cassette inserted in the FCR PRIMA T2 (CR-IR 392), personal injury and/or damage to the FCR PRIMA T2 (CR-IR 392) may result.
3. When a long-view cassette is used, be sure to install toppling-prevention measures. If excessive force is applied to such a cassette being inserted in the FCR PRIMA T2 (CR-IR 392), the FCR PRIMA T2 (CR-IR 392) may topple over and cause injury.
4. Do not sit on the FCR PRIMA T2 (CR-IR 392) or apply your weight to it by leaning forward and placing your hands on the FCR PRIMA T2 (CR-IR 392) to keep the FCR PRIMA T2's (CR-IR 392) cassette set unit from breaking and to prevent possible injury from fragments or the like.
5. Do not put your finger into the FCR PRIMA T2's (CR-IR 392) cassette set unit since your finger may touch sharp edges inside and cut yourself.
6. Since system sensitivity (S value) varies over time and by other factors including system trouble, never use it for radiation-dose and/or AEC (phototimer) setting purposes.
7. If you use the S value as a measure of exposure dose for image-quality and exposed-dose control purposes or when you use FNC (Flexible Noise Control) processing, periodically determine whether the S value has changed noticeably in the meantime.
8. After checking information attached to radiographic images for correctness, use such information for image interpretation work.
9. Before inserting a cassette into the FCR PRIMA T2 (CR-IR 392), verify patient identification without fail by means of the patient's full name, birthdate and the like.
10. Before inserting a cassette into the FCR PRIMA T2 (CR-IR 392), be sure to read the exposure menu.
11. Before inserting a cassette into the FCR PRIMA T2 (CR-IR 392), make sure that the FCR PRIMA T2 (CR-IR 392) is in image-reading mode. This is because IP images are erased if the FCR PRIMA T2 (CR-IR 392) is in erase mode.
12. Do not subject the equipment or cassette to vibration while an image is being read. Otherwise, an image with unevenness or the like may be output, which will adversely affect image reading.
13. An inserted cassette should not be taken out until the cassette ejection lamp blinks (blue). If you try to pull out such an in-process cassette, it becomes the unremovable.
14. Do not insert an unspecified cassette into the Image Reader. If an unspecified cassette is inserted into the Image Reader, image reading is disabled. Be sure to use a specified cassette.
15. Do not place an unspecified IP into the cassette and place an IP into a specified cassette, otherwise an image that may affect image reading can be output, and it is possible that an IP, a cassette, or the FCR PRIMA T2 (CR-IR 392) is damaged.
16. Replace the erasure lamp when the error code prompting for replacement is displayed. For the replacement of the lamp, please contact your local authorized distributor. When the lamp fails, image erasure becomes impossible.
17. Do not remove a cassette already subjected to exposure before image reading. It is possible that a read image is lost.
(For precautions to observe when reading images from an IP, make sure to see **[Z.1 Precautions to Take Before Exposure]** in "FCR PRIMA T2 Reference Guide" so that IPs are handled correctly.)
18. Use the table, cassette rack, etc. only for this equipment. Use these items following the instructions in the manual. Do not use them as a ladder, a seat or a chair with arm rests. Also, do not put unspecified goods on them. It may cause personal injury, and the items may be damaged.
19. Use a table or board that can withstand a load of more than 150kg (331lb) and has sufficient space for installing FCR PRIMA T2 (CR-IR 392) on it.

1.6 Location of Each Label and Mark

Shown below are the positions where the FCR PRIMA T2 (CR-IR 392) labels and mark are affixed.

1.6.1 Locations

For Safe Operation

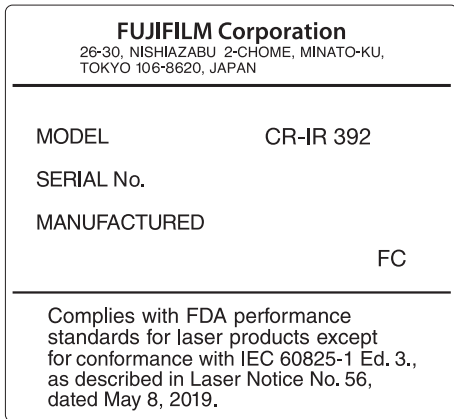
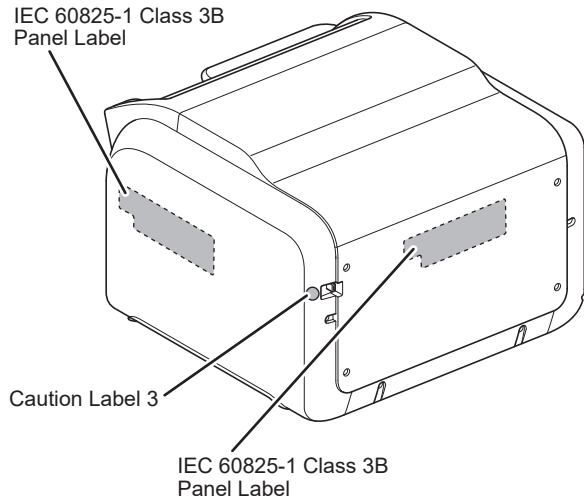
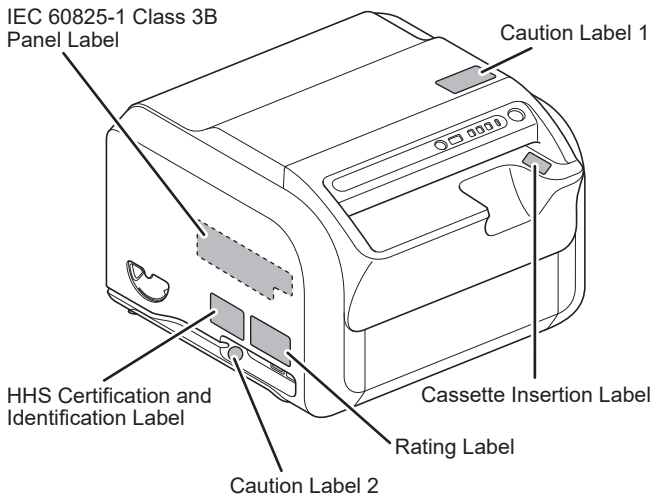

HHS Certification and Identification Label

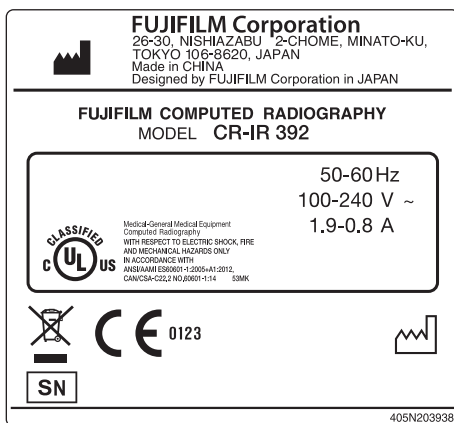

Rating Label

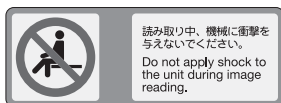

Caution Label 1

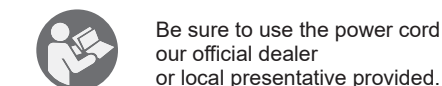

Caution Label 2

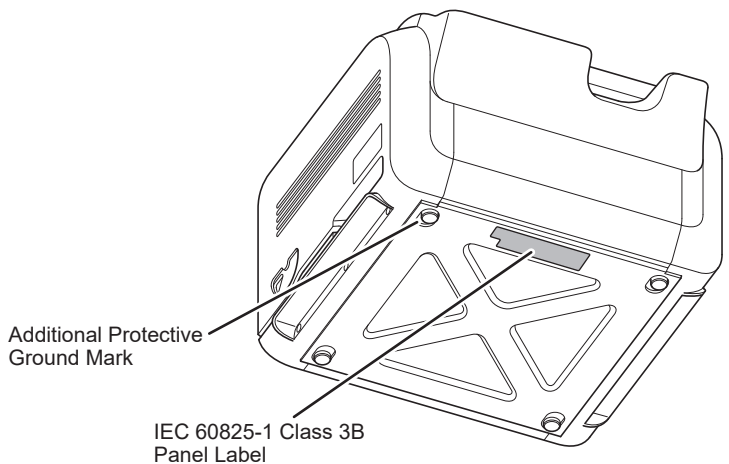

Additional Protective Ground Mark

IEC 60825-1 Class 3B Panel Label

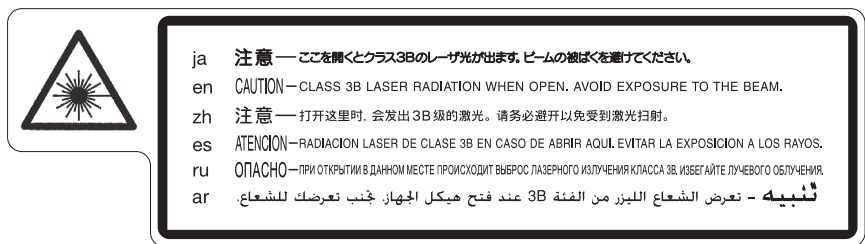

IEC 60825-1 Class 3B Panel Label
(The dotted labels in the illustrations above are affixed to the inside of the cover and are invisible from the outside.)



Caution Label 3



Additional Protective Ground Mark













Do not connect telephone lines to LAN connector. Only the IEC 60950-1/EN 60950-1 standard non-shielded cables are appropriate for connection to this connector.



Cassette Insertion Label

1.6.2 Safety and Other Signs

The following safety signs are used in the FCR PRIMA T2 (CR-IR 392) labels or on its body.

Sign	Description
	This symbol indicates compliance of the equipment with Directive 93/42/EEC.
	Laser Caution
	Attention, consult ACCOMPANYING DOCUMENTS.
	Power-OFF
	Power-ON
	Protective grounding (to the earth)
	Alternating current
	<p>This symbol indicates that this product is not to be disposed of with your household waste, according to the WEEE Directive (2002/96/EC) and your national law. This product should be handed over to a designated collection point.</p> <p>Improper handling of this type of waste could have a possible negative impact on the environment and human health due to potentially hazardous substances that are generally associated with EEE.</p> <p>At the same time, your cooperation in the correct disposal of this product will contribute to the effective usage of natural resources.</p> <p>For more information about waste, please contact FUJIFILM dealers.</p>
	Date of manufacture
	Stand-by switch
	No sitting
	Serial number
	Manufacturer



For Safe Operation

Chapter 2 Product Overview

2.1 Features of the FCR PRIMA T2 (CR-IR 392)

The FCR PRIMA T2 (CR-IR 392) is equipment designed to read X-ray image information recorded on an imaging plate (IP). The IP is used as an X-ray image detector. It records the image information of an image captured by an X-ray exposure.

This section explains features of a system employing the FCR PRIMA T2 (CR-IR 392) and FCR PRIMA T2 (CR-IR 392)-equipped system configuration examples.

The system can be used for chest, abdomen, bone, spine, head and other plain X-ray imaging, as well as spinal canal, bronchial tube, urinary organ, and other contrast medium X-ray imaging and X-ray tomography.

Major features of the system include:

- 1 By virtue of the effects of digital image processing, the system produces radiographs that have a high diagnostic value and are easy to interpret.
- 2 The system has a wide latitude for incident X-rays so that a large amount of X-ray diagnostic information can be obtained.
- 3 The system features high sensitivity, making it possible to reduce X-ray radiation doses or exposure to patients.
- 4 As the system takes an advantage of a wide latitude and an automatic sensitivity adjustment function, the image reading results of radiographs remain virtually unaffected by small variations in X-ray exposure conditions. Therefore, high image-density consistency can be obtained among radiographs.
- 5 Exposure information items that include patient information, anatomical regions and exposure menus can be entered on the console connected to the FCR PRIMA T2 (CR-IR 392).
- 6 Due to the compact size of the system, it can be installed in a relatively tight space.
- 7 The cassette can be inserted horizontally, making it easy to operate the system on the table.

2.2 Units Names and the Functions

Described below are units component of the FCR PRIMA T2 (CR-IR 392) main unit and the Operation Panel.

2.2.1 FCR PRIMA T2 (CR-IR 392) Main Unit

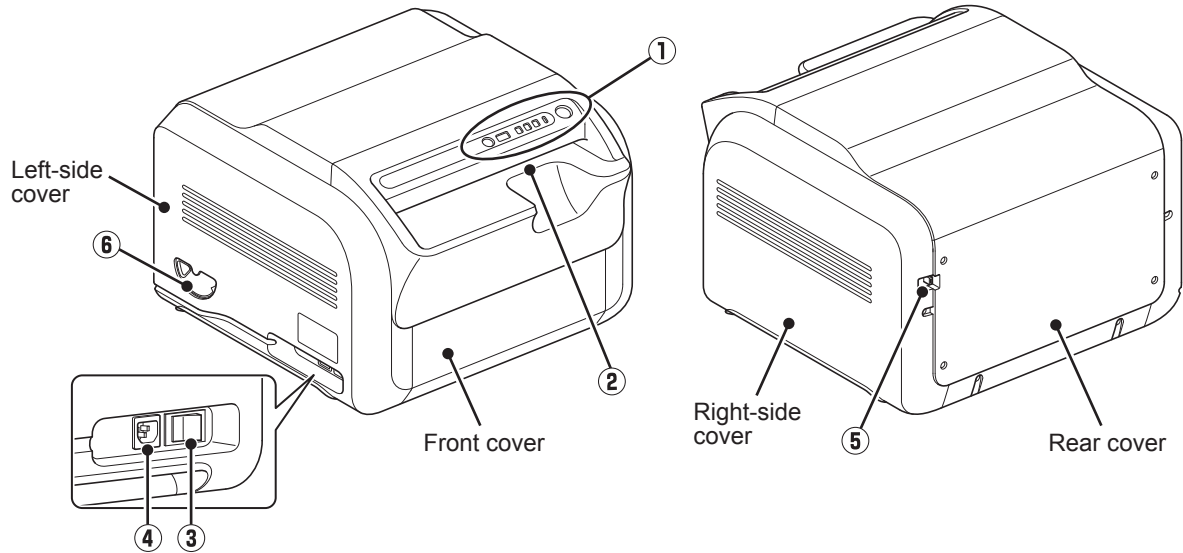







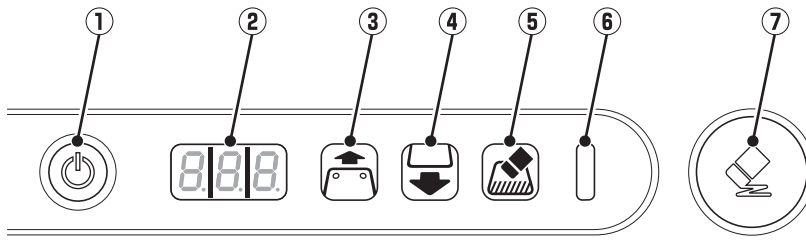

Name	Function
① Operation Panel	Operation panel for the FCR PRIMA T2 (CR-IR 392).
② Cassette Set Unit	Used for inserting cassette that contains an exposed IP.
③ Main Power Switch	Leave it turned ON. ON (I): Main Power ON OFF (O): Main Power OFF
④ Power Inlet	Power inlet for this equipment.
⑤ External Device Connector (I/F Cable)	Used for network-connecting the external device.
⑥ Scanner Cleaning Handle	Used for cleaning the Scanner.

CAUTION

- Do not connect telephone lines to LAN connector.
Only the IEC 60950-1/EN 60950-1 standard non-shielded cables are appropriate for connection to this connector.
- Plug the power cord firmly into the power inlet.
- When plugging/unplugging the power cord, hold its connector to avoid excessive force to the cord.

2.2.2 Operation Panel







Name	Function
① Stand-by Switch	 Turns on/off the power to the FCR PRIMA T2 (CR-IR 392). This switch is used when the FCR PRIMA T2 (CR-IR 392) is started up singly. When the buzzer sounds because of an error or detection of excessive amount of X-rays and this switch is pressed, the buzzer stops and the cassette lock is released. To turn off the unit, keep pressing the switch for about four seconds.
② Status Display LED	 Indicates status of the unit. 000 : Initializing End : End processing oFL : Console unconnected onL : Console connected Blinking : Error/Warning indication number
③ Cassette Ready Lamp	 Lights up (green) when it is ready for inserting a cassette. You can not insert the cassette when this lamp is off. When the lamp is on alternately with the Cassette Removal Lamp, an unprocessed cassette is ejected.
④ Cassette Removal Lamp	 Blinks (blue) when it is ready for ejecting the processed cassette. Lights off when you remove the cassette. When this lamp is on alternately with the Cassette Ready Lamp, an unprocessed cassette is ejected. When this lamp is on alternately with the Excessive amount of X-ray Display Lamp, the Excessive amount of X-ray erasing-incomplete cassette is ejected. Press the Eraser Button and Perform an erasure. Note that it takes a lot of time to achieve erasure.
⑤ Excessive amount of X-ray Display Lamp	 If X-ray of about 400 mR and over is detected, this lamp blinks alternately with the Cassette Removal Lamp, and the excessive amount of X-ray erasing-incomplete cassette is ejected. Press the Eraser Button and perform an erasure. Note that it takes a lot of time to achieve erasure. If erasing is to be done later, remove the cassette. If the cassette is to be used the next time, always perform erasing after 16 hours have passed before using the cassette.
⑥ Power/Erasing Mode Indicator Lamp	 Lights up with green color when the main power switch is set to ON and turns to orange color under the erasing mode.
⑦ Eraser Button	 Switches the mode from reading to erasing. When you erase IP images, press this button to switch to the erasing mode.

▶ For details, see [4.4 When An Error Code Appears] in the Reference Guide.





2.2.3 Operation Panel Display at the Time of Startup/Shutdown

Operation panel lamp display with ON/OFF operation of main power switch and stand-by switch and the change of the status display LED are shown below.





- Display status when the main power switch is set to ON

Status	Power/Erasing Mode Indicator Lamp	Status Display LED	Excessive amount of X-ray Display Lamp	Cassette Removal Lamp	Cassette Ready Lamp
					
Main power switch is set to ON	ON(orange)	888	ON	ON	ON
During console application startup/ FCR PRIMA T2 initialization	ON(green)	000	OFF	OFF	OFF
FCR PRIMA T2 initialization completion/ Console not connected		oFl			
FCR PRIMA T2 initialization completion/ Console connected		onL			
FCR PRIMA T2 initialization completed/ Study by Console not yet started					
FCR PRIMA T2 initialization completed/ Study by Console started → cassette insertion possible					

- Display status when the stand-by switch is set to ON

Status	Power/Erasing Mode Indicator Lamp	Status Display LED	Excessive amount of X-ray Display Lamp	Cassette Removal Lamp	Cassette Ready Lamp
					
Stand-by switch is OFF	ON(green)	OFF	OFF	OFF	OFF
Stand-by switch is ON/ During Console application startup/ FCR PRIMA T2 initialization		000			
FCR PRIMA T2 initialization completion/ Console not connected		oFl			
FCR PRIMA T2 initialization completion/ Console connected		onL			
FCR PRIMA T2 initialization completed/ Study by Console not yet started		onL			
FCR PRIMA T2 initialization completed/ Study by Console started → cassette insertion possible		onL			

- Display status when the stand-by switch is set to OFF

Status	Power/Erasing Mode Indicator Lamp	Status Display LED	Excessive amount of X-ray Display Lamp	Cassette Removal Lamp	Cassette Ready Lamp
					
FCR PRIMA T2 initialization completion/ Console connected	ON(green)	onL	OFF	OFF	OFF
FCR PRIMA T2 is in shutting down operation		End			
Stand-by switch is OFF		OFF			

Chapter 3 Basic Operation

3.1 Performing Erasure Before Use IPs

In order to prevent image degradation of IPs that you are going to use for the first time for the day's work, perform erasure on them before use.

If IPs to be used for the day's radiographic exposure work are not yet used on the day, it is necessary to perform erasure on them. In the course of this erasure, any excess energy each IP has accumulated is dissipated. Even when the IP is stored in a room, it absorbs and accumulates natural radiation such as cosmic rays and radiation energy emanating from radioisotopes contained in construction materials such as those used for floors and walls. If such an energy-loaded IP is used as-is, image degradation may result. Precautions to observe before using an IP or when deleting images from an over-exposed IP

▶ See [Z.1.2 Precautions to Observe Before Using an IP] in the Reference Guide.

By using the following procedure, perform erasure of the image on the IP.

1 Press the [Eraser] button.

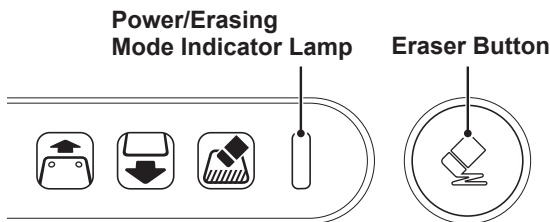

The power/erasing mode indicator lamp will be turned from green to orange.

2 Insert a cassette.

Erasure will be performed.
Upon completion of the erasure, the cassette removal lamp will blink.

3 Remove the cassette.

3.2 System Startup/Shutdown and Image Reading (Console)

The startup and shutdown of the FCR PRIMA T2 (CR-IR 392) is performed under the control of the Console's power ON/OFF switch.

To start up only the FCR PRIMA T2 (CR-IR 392), use the procedure described in **[3.3 Starting Up/ Shutting Down the FCR PRIMA T2 Main Unit]**. In sections coming hereafter where the system operation is explained, the "FCR PRIMA T2 (CR-IR 392)" is expressed simply as "FCR PRIMA T2."

* In case of using the console other than the one of CR-IR 391CL, refer to the manual attached to the console.

3.2.1 Starting Up the System

- 1 Confirm that the power/erasing mode indicator lamp on the FCR PRIMA T2's operation panel is on.

If the power/erasing mode indicator lamp is not lit, turn ON the main power switch.

Status when initialization has been completed and the console is not yet connected

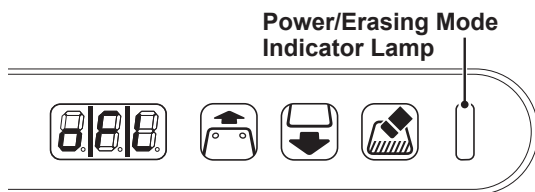

Console unconnected: **o f L**

- 2 Firstly, press the power ON/OFF switch of the Console's monitor, and secondly press the power ON/OFF switch of the Console itself.



The Console's application software starts.

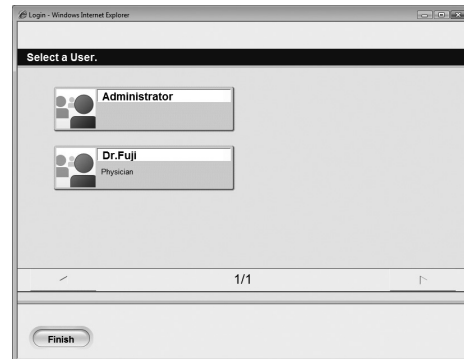

When start of the console application software has been completed, the user selection screen is displayed. When FCR PRIMA T2 becomes connected by console operation, the status display LED of the FCR PRIMA T2 operation panel changes from console not connected status to console connected status. When study is started from the console, the cassette ready lamp (green) lights.

Status when the console has been connected and study has been started

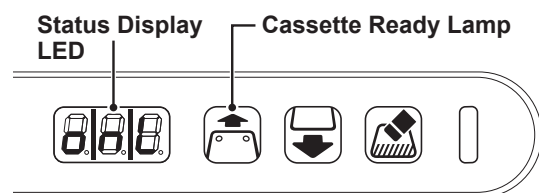

Console connected: **o n L**

3.2.2 Shutting Down the System

- 1 If a cassette is still inserted, make certain that the FCR PRIMA T2 has finished reading, and then remove the cassette.

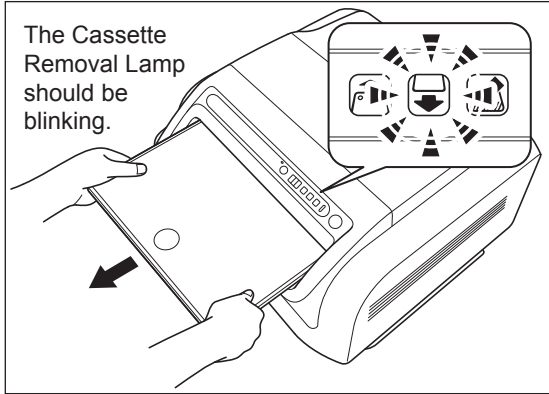

- 2 On a screen from which the console can be shut down, select .

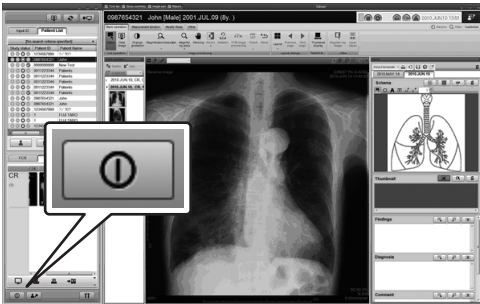

- 3 The following dialog appears. Confirm that the “Shutdown the PC” is selected and press [OK].

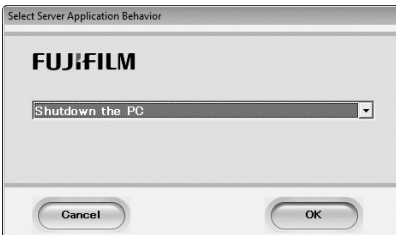

The system is turned OFF automatically.

- 4 Turn the monitor OFF.

 **HINT**

For the operation of the User Utility, refer to the appropriate sections of the Console's Operation Manual.

- 5 Turn OFF the Main Power Switch of the FCR PRIMA T2.

3.2.3 Reading Cassette IP Images

CAUTION

Before using a cassette, ensure that it is applicable to the Image Reader. Using a cassette not applicable to the Image Reader will disable image reading on it.

Before reading a cassette IP image, register patient information and study menus on the Console for the purpose of X-raying the patient. Described herein is the procedure covering steps up to reading exposed images.

1 Input patient information and then select study menus and exposure menus on the Console.

For details on how to register patient information and operate study menus on the Console, refer to the appropriate sections of the Console's Operation Manual.

HINT

For details of available image reading mode, refer to the Operation Manual that describes the User Utility functions of the connected Console.

2 Subject a patient to X-ray exposure.

3 Read the exposed image with the FCR PRIMA T2.

Explained below is the procedure to read IP images of a cassette inserted into the FCR PRIMA T2.

1. Confirm that the Cassette Ready Lamp is lit (green) on the operation panel.

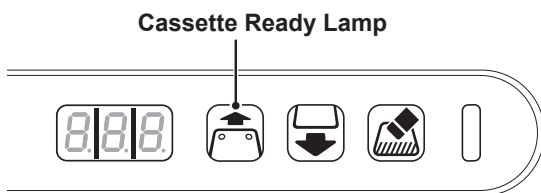

2. Insert a cassette into the equipment in alignment with the guide on the right, with the cassette's product name label facing as illustrated below.

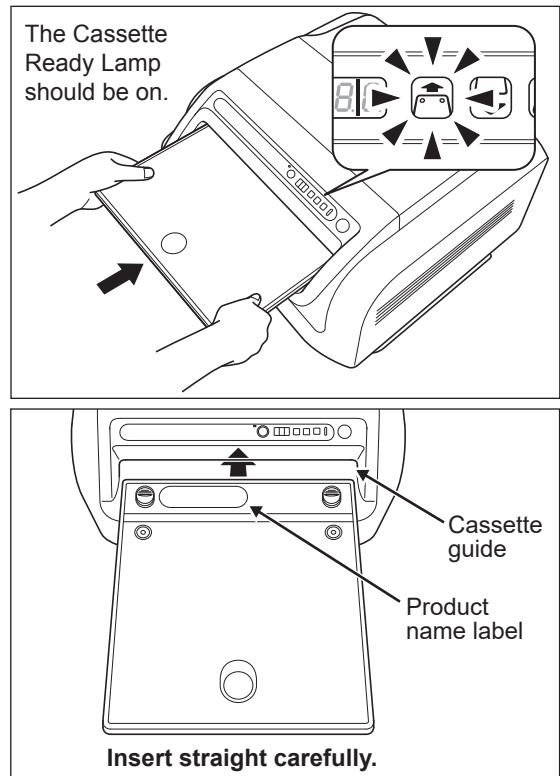

CAUTION

- Insert the cassette in the FCR PRIMA T2 after confirming the sides and the direction of the cassette. Moreover, insert the cassette straight and slowly. If a cassette is inserted incorrectly wrong side or direction, like at a slant, the Image Reader can be damaged.
- When inserting the cassette, be careful not to pinch your finger between the cassette and the cassette set unit.
- Do not turn the scanner cleaning handle during IP processing.

- Remove the exposure marker from the cassette before inserting the cassette in the Image Reader.
- In case of inserting a cassette of other devices, or inserting a cassette in the wrong direction, an error will be occurred.
- Do not shake the Image Reader while reading the image. Such as uneven image, which will prevent image reading, might be generated.

3. Confirm that the Cassette Removal Lamp is blinking (blue) on the operation panel and then remove the cassette.

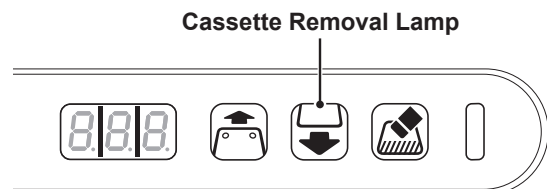

3.3 Starting Up/Shutting Down the FCR PRIMA T2 Main Unit

This section explains how to start up/shut down the FCR PRIMA T2 main unit.
To operate the Console, use the procedure described in [3.2.1 Starting Up the System].

Starting up the FCR PRIMA T2 main unit

⚠ CAUTION

An error may occur if you turn on the Main Power Switch of FCR PRIMA T2 right after turning it off. Once turning it off, wait at least 15 seconds before turning it on again.

1 Turn ON the Main Power Switch of the FCR PRIMA T2.

Ensure that the Main Power Switch of the FCR PRIMA T2 has been turned ON.

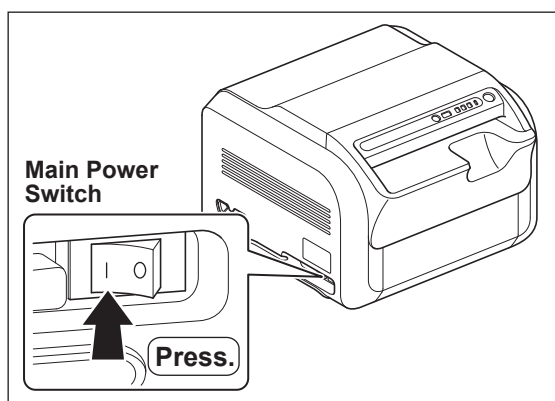

2 Press the Stand-by Switch on the operation panel to turn the power ON.

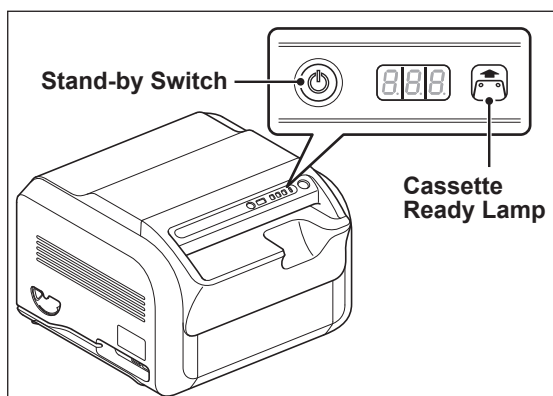

The FCR PRIMA T2 starts initialization operation. When the FCR PRIMA T2 is up and running, the cassette ready lamp lights on the operation panel.

- ▶ See [2.2.3 Operation Panel Display at the Time of Startup/Shutdown] for the operation panel display at the time of FCR PRIMA T2 start.

Shutting down the FCR PRIMA T2 main unit

1 Press the Stand-by Switch on the operation panel for four seconds.

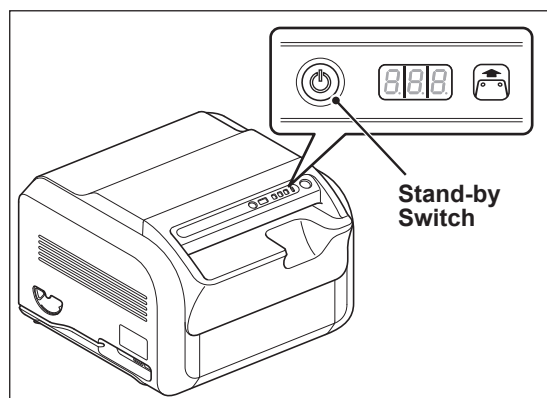

The status display LED changes from off-line to shutdown processing. When FCR PRIMA T2 shuts down, the status display LED goes out.

- ▶ See [2.2.3 Operation Panel Display at the Time of Startup/Shutdown] for the operation panel display at the time of FCR PRIMA T2 start.



Basic Operation

Chapter 4 Care and Maintenance

4.1 About Performing Daily Checks and Maintenance

In order to use the FCR PRIMA T2 always in good working order, perform daily checks and maintenance on it.

As for the daily checks, make certain that the FCR PRIMA T2 starts up normally and all equipment that is connected to the FCR PRIMA T2 can communicate normally with the FCR PRIMA T2. For daily care, clean the cassette set unit everyday.

Use the “Users Checksheet” when performing daily checks and maintenance. Enter the following items of information into the “Users Checksheet”:

- Checkups: Enter the date checks were performed.
- S value confirmation: Enter the date the S value was checked.
- Cassette set unit: Enter the date the cassette set unit was cleaned.

4.2 Cleaning the Cassette Set Unit

Perform cleaning, taking care not to let dust into the FCR PRIMA T2.

Wipe the cassette set unit with a dry cloth.

 **CAUTION**

Do not use organic solvents such as thinner, benzine, etc.

4.3 Users Check Sheet

We recommend that you periodically check the following so that you can optimally operate the equipment constantly. Make a copy when you are using this check sheet.

• Verification

Details	Frequency	Date of verification
Does the equipment start up normally?	Daily	/
		/
		/
		/
		/
Is the communication possible normally with the connected equipment?	Daily	/
		/
		/
		/
		/
Does the S value remain constant?	Every six months	/

• Cleaning

Unit for cleaning	Frequency	Date of cleaning
Cassette set unit	Every three months	/
		/
		/
		/
		/

4.4 About Preventive Maintenance

To maintain safety for the customer, the user, and other people, perform the preventive maintenance mainly involved cleaning of the parts and replacing of consumables. For the preventive maintenance, consult our official dealer or local representative.

The timing of performing preventive maintenance or the replacement cycle of periodic replacement parts differs depending on cassette usage and running time of this equipment per day. The preventive maintenance of machine performed by the specified dealer differs depending on the contents of contract.

CAUTION

The life of this equipment is six years.

To use the equipment after this period, contact a designated service supplier to perform an overhaul.

For maintenance and inspection after that, consult with a designated service supplier.

■ Timing of the Preventive Maintenance

The timing of the preventive maintenance are shown below.

- One year or when a process count of about 6,000 is reached
- Two years or when a process count of about 12,000 is reached
- Three years or when a process count of about 18,000 is reached
- Four years when a process count of about 24,000 is reached
- Five years when a process count of about 30,000 is reached

■ Preventive maintenance to be performed when the machine has been used for one year or when a process count of about 6,000 is reached

Perform the preventive maintenance shown below.

Cleaning of the parts

- Reflection plate, and filter of the erasure unit
- Covers, shutter

Checking the Machine

- Erasure lamp lighting time
- Protective grounding
- Image/conveyance
- S value
- Error log

■ Preventive maintenance to be performed when the machine has been used for two years or when a process count of about 12,000 is reached

Perform the preventive maintenance shown below.

Cleaning of the parts

- Suction cups, rubber rollers
- Reflection plate, and filter of the erasure unit
- Light-collecting guide
- Covers, shutter

Checking the Machine

- Erasure lamp lighting time
- Protective grounding
- Image/conveyance
- S value
- Error log

■ Preventive maintenance to be performed when the machine has been used for three years or when a process count of about 18,000 is reached

Perform the preventive maintenance shown below.

Cleaning of the parts

- Reflection plate, and filter of the erasure unit
- Covers, shutter

Checking the Machine

- Erasure lamp lighting time
- Protective grounding
- Image/conveyance
- S value
- Error log

■ Preventive maintenance to be performed when the machine has been used for four years or when a process count of about 24,000 is reached

Perform the preventive maintenance shown below.

Cleaning of the parts

- Suction cups, rubber rollers
- Reflection plate, and filter of the erasure unit
- Light-collecting guide
- Covers, shutter

Checking the Machine

- Erasure lamp lighting time
- Protective grounding
- Image/conveyance
- S value
- Error log

■ Preventive maintenance to be performed when the machine has been used for five years or when a process count of about 30,000 is reached

Perform the preventive maintenance shown below.

Cleaning of the parts

- Reflection plate, and filter of the erasure unit
- Covers, shutter

Checking the Machine

- Erasure lamp lighting time
- Protective grounding
- Image/conveyance
- S value
- Error log

Appendix A Specifications

A.1 Specifications

A.1.1 Details of Equipment Specifications

<p>Power Supply Conditions</p> <p>Input voltage: 100-240 V~ Allowable variations in voltage: $\pm 10\%$ Rated current: 1.9-0.8 A Frequency: 50-60 Hz Phase: Single</p>	
<p>Environmental Conditions</p> <p>(1) Operating conditions Temperature: 15°C (40% RH) - 30°C (80% RH) Humidity: 15% RH (30°C) - 80% RH (30°C) (no dew condensation) Atmospheric pressure: 750 hPa-1060 hPa</p> <p>(2) Non-operating conditions Temperature: 0°C-45°C (no freeze condensation) Humidity: 10% RH-90% RH (no dew condensation) Atmospheric pressure: 750 hPa-1060 hPa</p>	
<p>Available IP/Cassette</p> <p>(1) IP FUJI IP</p> <ul style="list-style-type: none"> Type ST-VI Inch: 14×17", 14×14", 10×12" and 8×10" Metric: 35×43 cm, 35×35 cm, 24×30 cm, 18×24 cm and 15×30 cm* * The 15×30 cm IP can be used, even if the default is set to inch. <p>(2) Cassette</p> <ul style="list-style-type: none"> Fujifilm IP Cassette CC (ST type cassette) Inch: 14"×17" (35×43 cm), 14"×14" (35×35 cm), 10"×12" (25.2×30.3 cm), 8"×10" (20.1×25.2 cm) Metric: 24×30 cm, 18×24 cm and 15×30 cm Fujifilm IP Cassette LC (for long-view exposure) Long-view double cassette Inch: 14"×17" and 10"×12" Metric: 24×30 cm Long-view triple cassette Inch: 14"×17", 14"×14", 10"×12" 	
<p>Options</p> <p>Table fix kit, stand wagon, add stand for monitor, cassette rack, cassette rack for the long-view cassette, arm for monitor, stand wall fix kit, CPU floor mount kit, support bar for the long-view cassette.</p>	



Appendix A Specifications

Maintenance and Inspection

1 Maintenance and Inspection Items Assigned to Specified Dealer

For periodical inspection of the equipment and necessary arrangements, consult our official dealer or local representative.

FUJIFILM

 **FUJIFILM Corporation**

26-30, NISHIAZABU 2-CHOME, MINATO-KU, TOKYO 106-8620, JAPAN



0123



FUJIFILM Europe GmbH
Balcke-Duerr-Allee 6, 40882 Ratingen, Germany

EU Importer:
FUJIFILM Europe B.V.
Oudenstaart 1, 5047 TK Tilburg, The Netherlands

FUJIFILM Healthcare Americas Corporation
81 HARTWELL AVENUE, SUITE 300 LEXINGTON, MA 02421, U.S.A.